

This Owner's Manual is provided and hosted by [Appliance Factory Parts](#).



OCI OCI-40BQR Owner's Manual

[Shop genuine replacement parts for OCI OCI-40BQR](#)



[Find Your OCI Grill Parts - Select From 22 Models](#)

----- Manual continues below -----



PRO- PERFORMANCE SERIES USE AND CARE MANUAL



MODELS:

OCI-26BQ / OCI-30BQR / OCI-40BQR
LP GAS and NATURAL GAS MODELS
R = Rotisserie Burner included on Grill.

INSTALLERS please hand this manual to Home Owner for Safety and Care Instructions.

A MESSAGE TO OUR CUSTOMERS

Thank you for selecting the OCI PRO-PERFORMANCE Grill. We have worked hand in hand with top designers to create a product that meets exacting standards and will provide Years of pleasurable, outdoor grilling with exceptional results.

Because the grill has features not found on any other, we recommend that you read this entire booklet before your first use. Then, keep it in a handy place along with your sales receipt as it has an answer to many questions that may arise during use. There is also important safety information in the manual that you must read for correct built in gas grill installation.

Please contact us at any time if we can help you with questions about parts and use at
1 (888) 419-0888

To register your grill please go to OCIPROGRILL.COM and fill out the quick registration form.



PRO- PERFORMANCE SERIES

CALIFORNIA PROPOSITION 65 - WARNING

The Burning of gas cooking fuel generates some by products which are on the list of substances which are known by the State of California to cause cancer or reproductive harm. California law requires businesses to warn customers of potential exposure to such substances. To minimize exposure to these substances, always operate this unit according to the use and care manual, ensuring you provide good ventilation when cooking with gas.

TESTED IN ACCORDANCE WITH ANSI Z21.58a-1998/CGA 1.6a-M98 STANDARD FOR OUTDOOR COOKING GAS APPLIANCES. THIS GRILL IS FOR OUTDOOR USE ONLY.

Check your local building codes for the proper method of installation. In the absence of local codes, this unit should be installed in accordance with the National Fuel Gas Code No. Z223.1-1988 and the National Electrical Code ANSI/NFPA No. 70-1990.

NOTE: This product cannot be placed near or under combustible material.
Before installation consult your local city and fire department for direction.





PRO-PERFORMANCE SERIES

SAFETY PRECAUTIONS AND PRACTICES

Read this Care and Use Manual carefully and completely before using your grill to reduce the risk of fire, burn hazard or other bodily injury. Begin by ensuring proper assembly.

Do not repair or replace any part of the grill unless specifically recommended in this manual. All other service should be referred to a qualified technician and contractor / city and fire department.

Children should not be left alone or unattended in an area where the grill is being used. Never allow them to sit, stand or play on or around the grill at any time.

Do not store items of interest to children around or below the grill or in the cart. Never allow children to crawl inside of a cart.

Never let clothing, potholders or other flammable materials come in contact with or too close to any grate, burner or hot surface until it has cooled. Fabric may ignite and result in personal injury. For personal safety, wear proper apparel. Loose fitting garments or sleeves should never be worn while using this appliance. Some synthetic fabrics are highly flammable and should not be worn while cooking.

Only certain types of glass, heat-proof glass ceramic, earthenware, or other glazed utensils are suitable for grill use. Use of these types of materials may break with sudden temperature changes. Use only on low or medium heat settings according to the manufacturer's directions.

Do not heat unopened food containers as a build-up of pressure may cause the container to burst.

Use a covered hand when opening the grill lid. Never lean over an open grill.

When lighting a burner, always pay close attention to what you are doing.

When using the grill: do not touch the grill rack, burner grate or immediate surrounding area as these areas become extremely hot and could cause burns.

Do not use the grill for cooking excessively fatty meats or products which promote flare-ups.

Use only dry potholders: moist or damp potholders on hot surfaces may cause burns from steam. Do not use a towel or bulky cloth in place of potholders. Do not let potholders touch hot portions of the grill rack. Grease is flammable. Let hot grease cool before attempting to handle it. Avoid letting grease deposits collect in the bottom of the grill. Clean often.

Do not use aluminum foil to line the grill racks or grill bottom. This can severely upset combustion air flow or trap excessive heat in the control area. The result of this can be melted knobs, and increased chance of personal injury.

FOR YOUR SAFETY

If you smell gas:

- 1) Shut off gas to the appliance
- 2) Extinguish any open flames
- 3) Open Lid
- 4) If odor continues, immediately call a gas professional or Fire Dept.

WARNING

DO NOT try and light this appliance without reading the "LIGHTING INSTRUCTIONS" section of this manual.

FOR YOUR SAFETY

- 1) Do not store or use gasoline or other flammable vapor and liquids in the vicinity of this or any other appliance
- 2) An LP cylinder not connected for use shall not be stored in the vicinity of this or any other appliance

1) This appliance is not intended to be installed in or on recreational vehicles and/or boats.

2) Always maintain proper clearances from any/all flammable material.

3) This appliance cannot be located under overhead combustible material





PRO- PERFORMANCE SERIES

SAFETY PRECAUTIONS AND PRACTICES

Always inspect the gas hose(s) before each use. If the hose shows evidence of excessive abrasion or wear, or the hose is cut; it must be replaced prior to operating the appliance. Any replacement must be that specified by the manufacturer.

The pressure regulator and hose assembly supplied with the unit must be used. Replacements regulators and hoses must be those specified by the manufacturer.

For proper lighting and performance of the burners keep the ports clean. It is necessary to clean them periodically for optimum performance. The burners will only operate in one position and must be mounted correctly for safe operation.

Clean the grill with caution. Avoid steam burns; do not use a wet sponge or cloth to clean the grill while it is hot. Some cleaners produce noxious fumes or can ignite if applied to a hot surface.

Insect Warning!!! Spiders and insects can nest in the burners of this and any other grill, and cause the gas to flow from the front of the burner. This is a very dangerous condition which can cause a fire to occur behind the valve panel, thereby damaging the grill and making it unsafe to operate. Inspect the grill at least twice a year.

Be sure all grill controls are turned off and the grill is cool before using any type of aerosol cleaner on or around the grill. The chemical that produces the spraying action could, in the presence of heat, ignite or cause metal parts to corrode.

Do not operate the grill under unprotected combustible construction. Use only in well ventilated areas. Do not use in buildings, garages, sheds, breezeways or other such enclosed areas. **This unit is for outdoor use only.** Keep the area surrounding the grill free from combustible materials, trash, or combustible fluids and vapors such as gasoline or charcoal lighter fluid. Do not obstruct the flow of combustion and ventilation air.

If the unit is stored indoors ensure that it is cool. If propane is used, the cylinder must be unhooked and the propane cylinder stored outside in a well ventilated area, out of reach of children.

Keep the back of the cart free and clear from debris.

Keep any electrical supply cord, or the Rotisserie motor cord away from the heated areas of the grill.

Never use the grill in windy conditions. If located in a consistently windy area (oceanfront, mountaintop, etc.) a wind break will be required. Always adhere to the specified clearances.

Never use a dented or rusty propane tank.



IMPORTANT SAFETY NOTICE:

Certain Liquid Propane dealers may fill liquid propane cylinders for use in the grill beyond cylinder filling capacity. This “Overfilling” may create a dangerous condition.

“Overfilled” tanks can build up excess pressure. As a safety device, the tanks pressure relief valve will vent propane gas vapor to relieve this excess pressure. This vapor is combustible and therefore can be ignited. To reduce this danger, you should take the following safety precautions:

- 1. When you have your tank filled, be sure you tell the supplier to fill it to no more than 3/4 (75%) of its total capacity.**
- 2. If you own or use an extra spare tank, or have a disconnected tank, you should NEVER store it near or under the grill unit or near any other ignition or heat source.**

GRILL MODELS



OCI-26BQP / OCI-26BQN



OCI-32BQRP / OCI-32BQRN



OCI-40BQRP / OCI-40BQRN





PRO-PERFORMANCE SERIES

CLEARANCES/BTU RATING/LP TANK REQUIREMENT

CLEARANCE to Non-Combustible Construction:

A minimum of 16" clearance from the back of the grill to non-combustible construction is required for the lid to open fully.

To Combustible Construction:

below the cooking surface, maintain a minimum of 16" from the sides and a minimum of 14" from the back to adjacent vertical combustible construction.

Do not install this unit into combustible enclosures without an OCI insulated jacket!

LOCATION

When determining a suitable location take into account concerns such as exposure to wind, proximity to traffic paths and keeping any gas supply lines as short as possible. Locate the grill only in a well ventilated area. Never locate the grill in a building, garage, breezeway, shed or other such enclosed areas without an approved ventilation system. During heavy use, the grill will produce a lot of smoke.

Before any gas connections can be made, the cart must be assembled and the grill head mounted correctly to the cart. *Never connect an unregulated gas line to the appliance.*

	Main Burner	Back Burner
26" Grill	42000	N/A
32" Grill	56000	10,000
40" Grill	70000	10,000

The installation of this appliance must conform with local codes or, in the absence of local codes, with the national fuel gas code, ANSI Z223.1a-1988. Installation in Canada must be in accordance with the Standard Can1-b149.1 and/or .2 (installation code for gas burning appliances and equipment) and local codes.

L.P. TANK REQUIREMENTS

A dented or rusty L.P. tank may be hazardous and should be checked by your L.P. supplier. Never use a cylinder with a damaged valve. The L.P. gas cylinder must be constructed and marked in accordance with the specifications for L.P. gas cylinders of the U.S. Department of Transportation (DOT). The cylinder must be provided with a shut off valve terminating in an L.P. gas supply cylinder valve outlet specified, as applicable, for connection type Qcc1 in the standard for compressed gas cylinder valve outlet and inlet connection ANSI/CGA-V-1. Manifold pressure: 11" W.C.

L.P. GAS HOOK-UP:

Ensure that the black plastic grommets are in place and that the hose does not come into contact with the grill head or the heat shield.

CONNECTION:

Grill orifice for use with L.P. gas comes equipped with a high capacity hose/regulator assembly for connection to a standard 20 lb. L.P. cylinder (18-1/4" high, 12-1/4" diameter).

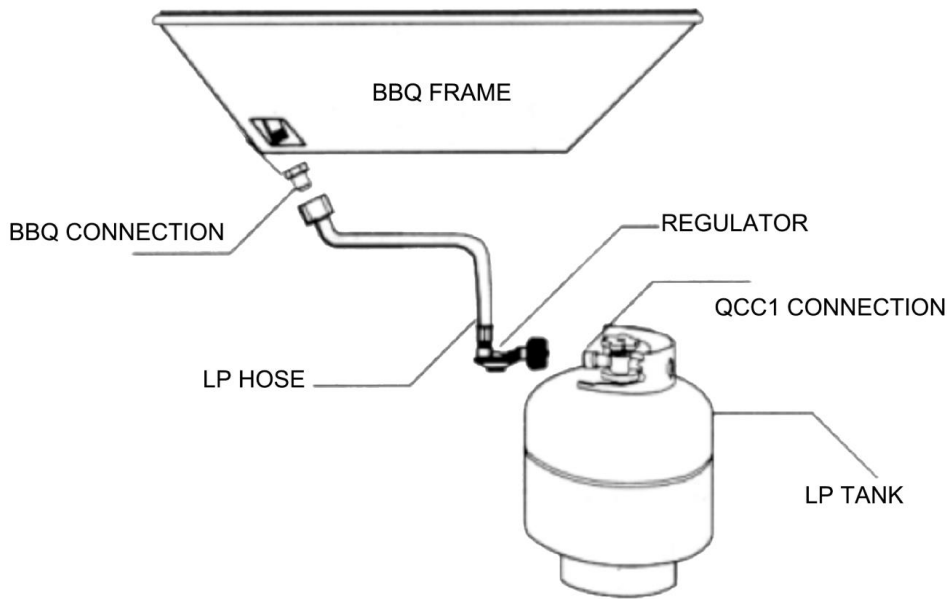

L.P. Gas Hook Up (Type or QCC-1 regulator):

Grill orificed for use with

L.P. gas come equipped with an L.P. hose/regulator assembly for connection to a standard 20 lb. L.P. cylinder (Type 1). The L.P. tank is not included.

Connection: 1/2" NPT male with a 3/8" Flare adapter. L.P. Hose with quick disconnect and fittings are included.

Operating pressure: 11.0" W.C.

Connect the 3/8" flare end of the L.P. Hose to the brass adapter on the Manifold (underneath bottom left corner).

ner). Connect the Regulator to the tank (with the tank valve fully closed). Although the flow of gas is stopped when the Type 1 system is disconnected; you should always turn the L.P. tank main valve off after each use and during transport of the tank or unit. Insert the regulator inlet into the tank valve and turn the black coupler clockwise until the coupler tightens up.

Do not over tighten the coupler.

Purging the system: Turn the main tank valve on and turn the burner control valves on the unit to the "light" position for about 20 seconds to allow the air in the system to purge before attempting to light the burners.

Do not attempt lighting the grill within 10 minutes after purging!

To disconnect the coupler, first make sure the main tank valve is turned off. Grasp the coupler and turn counter clockwise. The inlet will then disengage, remove the inlet from the tank valve opening if it has not already done so when it was disengaged. Your local L.P. filling station should be equipped with the proper equipment to fill your tank. If trading your tank in, always ensure to obtain only Type 1 20 lb cylinders with an overfill protection device.

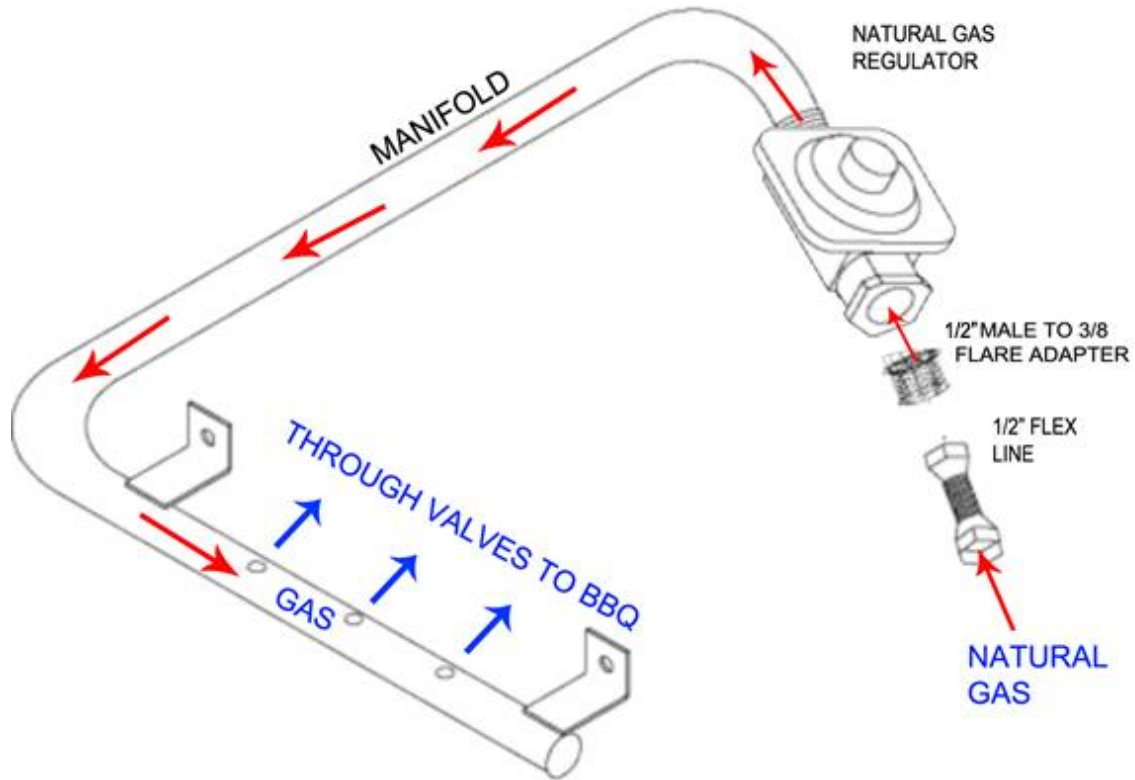

NATURAL GAS HOOK-UP

CONNECTION: 1/2" NPT male with 1/2" flare adapter and SS corrugated gas line.

OPERATING PRESSURE: 4.0" W.C.

SUPPLY PRESSURE: 5" TO 4" W.C. if in excess of 4" W.C. a step down regulator is required.

Check with your local gas utility company or with local codes for instructions on installing gas supply lines. Be sure to check on type and size of run, and how deep to bury the line. If the gas line is too small the Grill unit will not function properly.

To hook-up the fittings supplied with the Elite Grill unit: Assemble as shown in figure to the right. Use joint compound on male threads only.

Do not use joint compound on the flare end of the 1/2" NPT to 1/2" flare adapter. Ensure that the regulator arrow points in the direction of gas flow-towards the unit, away from the supply.

Do not forget to place an installer-supplied gas valve in an accessible location.



PRO-PERFORMANCE SERIES

LEAK TESTING

GENERAL

Although all gas connections on the grill are leak tested at the factory prior to shipment, a complete gas tightness check must be performed at the installation site due to possible mishandling in shipment, or excessive pressure unknowingly being applied to the unit. Periodically check the whole system for leaks, or immediately check if the smell of gas is detected.

Check all gas supply fittings for leaks before each use. It is handy to keep a spray bottle of soapy water near the shut-off valve of the gas supply line. Spray all the fittings. Bubbles indicate leaks. Always check for leaks after every L.P. tank change.

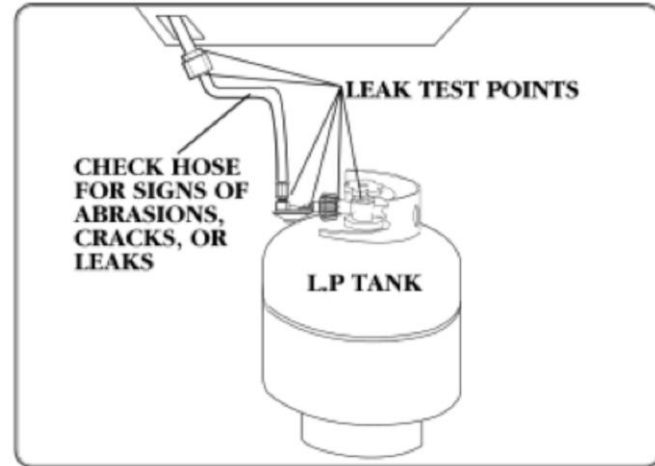

BEFORE TESTING

Make sure that all packing material is removed from the grill. Make a soap solution of one part liquid detergent and one part water. You will need a spray bottle, brush, or rag to apply the solution to the fittings. For L.P. units, check with a full cylinder.

Do not smoke while leak testing.

Never leak test with an open flame.

TO TEST

Make sure all control valves are in the "OFF" position. Turn the gas supply on. Check all connections from the supply line, or L.P. cylinder up to and including the manifold pipe assembly. Soap bubbles will appear where a leak is present. If a leak is present, immediately turn off gas supply, tighten any leaking fittings, turn gas on, and recheck. If you cannot stop a gas leak turn off the gas supply and call your dealer where you purchased your grill. Only those parts recommended by the manufacturer should be used on the grill. Substitution can void the warranty. **Do not use the grill until all connections have been checked and do not leak.**

Disconnected L.P. cylinders must have threaded valve plugs tightly installed, and must not be stored in a building, garage or any other enclosed area. The gas must be turned off at the supply cylinder when the unit is not in use. If the appliance is stored indoors the cylinder must be disconnected and removed from the appliance. Cylinders must be stored outdoors in a well ventilated area out of the reach of children.



PRO-PERFORMANCE SERIES

LIGHTING INSTRUCTIONS

WARNING: IMPORTANT!

Before lighting . . . Inspect the gas supply piping or hose prior to turning the gas “ON”. If there is evidence of Cuts, wear, or abrasion, it must be replaced prior to use. Do not use the grill if the odor of gas is present while the knobs are in the OFF position. The pressure regulator and hose assembly supplied with the unit must be used. Never substitute regulators for those supplied with the grill. If a replacement is necessary, contact the factory for proper replacement. Screw the regulator (Type QCC1) into the tank. Leak check the hose and regulator connections with a soap and water solution before operating the grill.

To Light Grill: Turn all knobs to “OFF” then turn on the gas supply. Always keep your face and body as far away from the grill as possible when lighting. Open the lid, push and turn the control knob to the “HIGH” position before the “CLICK” and wait until you hear gas then turn to the left and the gas will ignite automatically after the click. If the gas does not ignite redo the steps. **MAKE SURE** you wait until you hear the gas before you **CLICK**.

Match lighting: If the burner will not light after several attempts then the burner can be match lit. If you’ve just attempted to light the burner with the igniter, allow 5 minutes for any accumulated gas to dissipate. Keep your face as far away from the grill as possible and hold a lit match over the **FLASH TUBE** located on the right of the main grills. This tube leads gas up to be lit. Push and turn the right control knob which is centered on the burner to “HIGH”. If the burner does not light in 4 seconds turn the knob “OFF”, wait 5 minutes and try again. Make sure you check the ignition system for blockage or call a certified service agent to service the grill.

WARNING: Keep hands and face away from front of burner! STAND TO THE SIDE WHEN LIGHTING. ONCE LIT MOVE HAND AWAY QUICKLY.

Cross lighting: Once the left or right burner is lit, the adjacent burner(s) can be lit by the cross lighting method. Push and turn the control knob for the desired center burner to “HI”. The gas will be ignited by the adjacent burner’s flame and crossfires. If the burner does not light in 4 seconds, turn knob off, wait 5 minutes and try again.

Please note: cross lighting a grill burner next to an infra-red sear burner will not work!

Always cross light from the right burner to the left burner. The sear -burner cannot in any way be lit with the cross lighting method! Please use the match lighting or normal ignition method for the sear burner if your unit is equipped with an infra-red sear burner.

Please Note: Do not leave the hood in the **DOWN POSITION** for any length of time. Gas will build up and a potential for explosion will occur when ignited. **DO NOT** leave the grill unattended with minors. **ALWAYS** place the gas in the **OFF POSITION** when completed and turn off the gas supply to the **GRILL**

To Light Rotisserie: Open the lid, push and turn the control knob **SLOWLY** to the “HI” position and you will hear a clicking noise. At this time, a spark will be provided at the Rotisserie igniter. Once lit, turn control knob to desired setting. If the burner does not light within 4 seconds, turn control knob to “OFF”. If the igniter does not function, the burner can be lit by holding a lit match to the burner (with the control knob at “HIGH”).

Do not attempt to “LIGHT” the grill if the odor of gas is present. Call for service.

Keep a spray bottle of soapy water near the gas supply valve and check the connections before each use.

Always ensure that the burner is properly resting on the orifice prior to lighting the burner.



PRO-PERFORMANCE SERIES

SEAR BURNER MATCH LIGHTING INSTRUCTIONS

TO MATCH LIGHT THE OPTIONAL SEAR BURNER:

If you are unable to light Sear Burner using the “TURN AND CLICK” you can utilize a long match to match light the sear burner. Fit the match between the wire loops.

Position the lit LONG match down between the cooking grill rack approximately 1/4” above the burner. Turn the Valve to the lite/hi position to release gas to the burner. If burner does not light within 5 seconds, turn off burner, wait 5 minutes and try again. If you are unable to light the burner within three attempts call a service representative.

NOTE: While holding match holder stick be careful not to hold hand over burner area as this may cause serious burns or other personal injury.

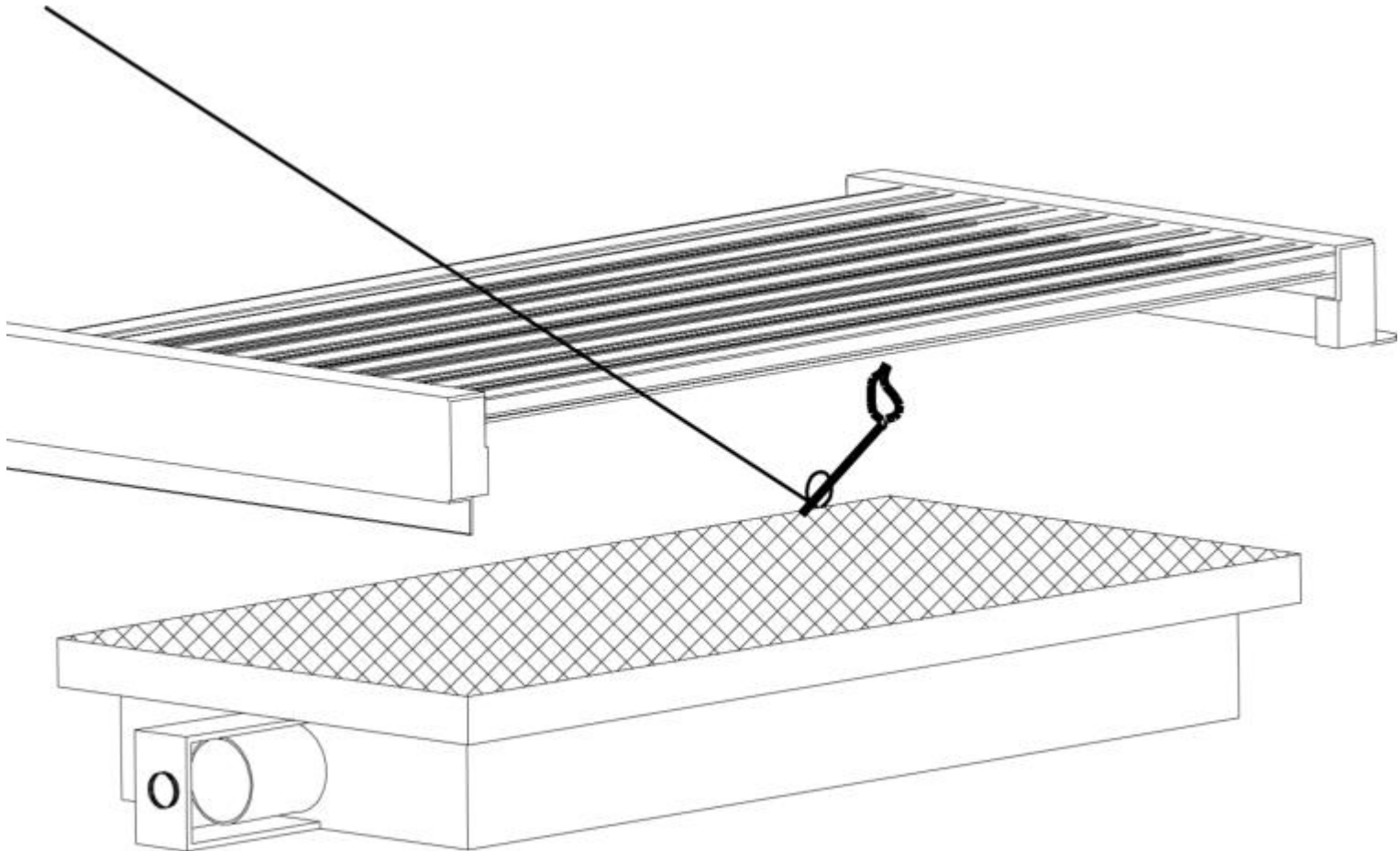

BURNER AIR ADJUSTMENT:

Each grill burner is tested and adjusted at the factory prior to shipment; however, variations in the local gas supply may make it necessary to adjust the burners. The flames of the burners should be visually checked and compared with Figure 01. Flames should be blue and stable with no yellow tips, excessive noise or lifting. If any of these conditions exist, check to see if the air shutter or burner ports are blocked by dirt, debris, spider webs, etc. Proceed with air shutter adjustment.

The amount of air, which is entrained into a burner is governed by a sheet metal cup at the inlet of the burner called an air shutter. It is locked in place by a set screw which must be loosened prior to lighting the burner for adjustment. The air shutter adjustment screws are accessible with a Philips screwdriver, remove the burner by lifting rear end first. Loosen the lock screw of the air shutter. **Make certain that the burners are sitting properly on the orifices and light the burners.** Adjust according to the following directions.

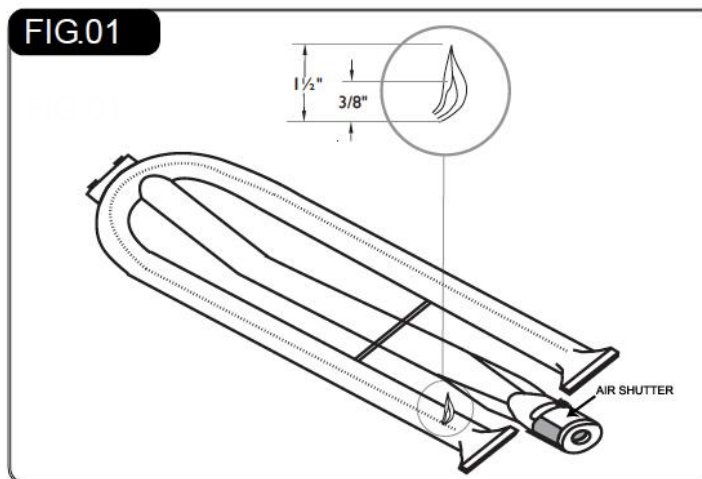

TO ADJUST GRILL BURNER FLAME:

Be careful as the burner may be very hot.

If the flame is yellow, indicating insufficient air, turn the air shutter clockwise to allow more air to the burner. If the flame is noisy and tends to lift away from the burner, indicating too much air, turn the air shutter counter-clockwise.

INSTALLER FINAL CHECKLIST

Specified clearances maintained to combustibles.

Air shutters adjusted.

USER, PLEASE RETAIN THESE INSTRUCTIONS FOR FUTURE REFERENCE

All internal packaging removed.

Pressure regulator connected and set for 11"W.C. L.P. gas.

Knobs turn freely.

Unit tested and free of leaks.

Burners are sitting properly on orifices.

User informed of gas supply shut off valve location.

Each burner lights satisfactorily, individually or with adjacent burner lit.



NOTE: THIS ADJUSTMENT SHOULD BE DONE WHEN CONVERTING TO NATURAL IF LP GAS AS WELL AS UPON FIRST USE.

LOW SETTING ADJUSTMENTS:

The valves on the Professional Grill features an Adjustable low setting. Due to fluctuations in gas pressure, heating value or gas conversion, you may feel it necessary to increase or decrease gas flow in the low position.

TO ADJUST:

1. Light the burner.
2. Turn the control knob to the lowest setting (all the way counter-clockwise)
3. Remove the knob.
4. Insert a thin tipped screwdriver into the screw and while viewing the flame adjust to a minimum stable flame.

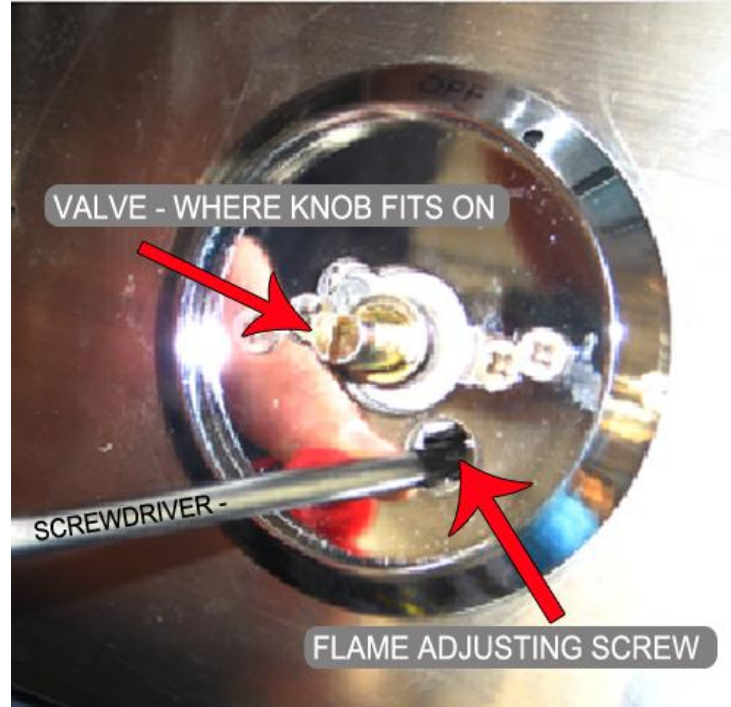

WHAT A "GOOD" FLAME SHOULD LOOK LIKE.

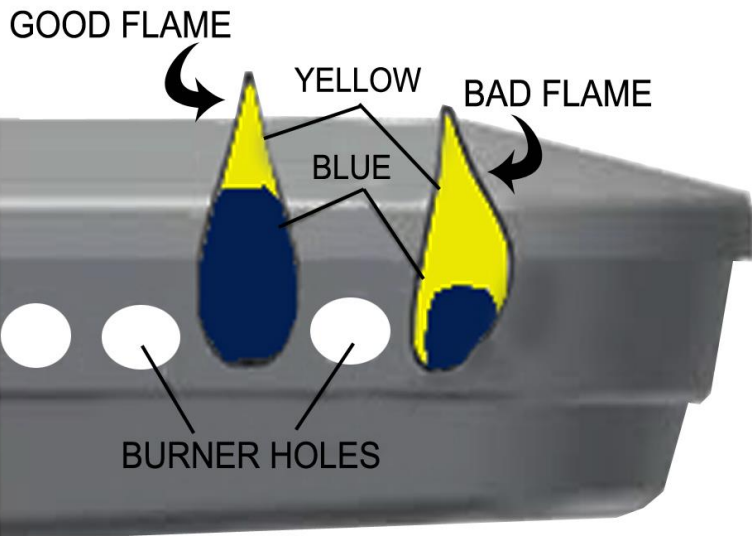



PRO-PERFORMANCE SERIES

USING YOUR GRILL

Each main burner is rated at 14,000 BTU. The grill burners encompass the entire cooking area. Above the burners are stainless steel briquette systems. The igniter button is built into the valves.

NOTE: A hot grill sears the food, sealing in the juices. The longer the preheat, the faster the meat browns and the darker the grill marks.

DO NOT leave the grill unattended while cooking. If you put the gas on and walk away from the grill there is a potential of the grill building up gas and an explosion can occur. ALWAYS switch gas off with hood open.

USING THE GRILL:

Grilling requires high heat for searing and proper browning. Most foods are cooked at the “HI” heat setting for Searing and then turned down to medium. However, when grilling large pieces of meat or poultry, it may be necessary to turn the heat to a lower setting after the initial browning. This cooks the food through without burning the outside. Foods cooked for a long time or basted with a sugary marinade may need a lower heat setting near the end of the cooking time.

1. Make sure the grill has been gas leak tested and is properly located.
2. Remove any packing material.
3. Light the grill burners using the instructions in this manual.
4. Turn the control knob to “HI” and preheat the grill for 15 minutes. The grill lid is to be closed during the appliance preheats period.
5. Place the food on the grill and cook to the desired doneness. Adjust heat setting, if necessary. The control knob may be set to any position between “HI” and “LO”.

NOTE: The grill must not be left alone while not lit. Gas will build up under the hood and a potential explosion may occur if you ignite the grill. Make sure that you never leave unattended with children.

WARNING: When using grill burners DO NOT use rotisserie burner as this may cause injury or severe burns. ALWAYS remove the Warming rack when using your Rotisserie system.

The PRO- PERFORMANCE grill includes a Griddle that can replace two grills on the bbq. Make sure that you wash this griddle for the first time as well as **ONLY USE FIREPROOF GLOVES** to pick the griddle up due to the extreme heat of the metal and you will burn your hands. The Griddle is 304 Stainless Steel and is rust resistant but surface rust may occur that is easily cleaned. Please store the Griddle inside the house for better protection. The griddle can be used for food that will fall through the grill such as fish, vegetables and breakfast bacon.

To minimize burn potential do not remove the griddle while HOT.

TO PRE-HEAT THE GRIDDLE:

Place the griddle in place or on top of the two cooking grills and remove the two briquette trays from above the burners. Place the unused grills and briquette system in a safe place. Preheat Griddle and clean down before use using a wet rag. Make sure that you do not use bare hands on the griddle for you will burn your hands or body. Make sure that you do not leave the grill unattended with minors for the griddle stays hot for a long time. To clean griddle use a wet rag and scraper and use caution for the material will stay hot.

WOOD CHIPS & OPTIONAL ACCESSORY SMOKER BOX:

There are many wood chips available for purchase and selection is based on personal taste. The most common wood chips used are mesquite or hickory. Mesquite has a sweeter taste and is commonly used with poultry and seafood. Hickory is best suited for red meats. Use of oak, cherry, maple, aspen or apple is also common while aromatic herbs like sage, bay leaves, thyme or basil may also be used. A accessory Smoker Box is available to place underneath the grills and enhance the flavor of your food. When smoking, the lid should remain closed as much as possible to maximize the effect. During extended roasting periods it is normal to add fresh wood chips to the tray several times.

ZONE GRILLING:

OCI Pro Performance Series grills are designed with the executive chef in mind. We consulted a number of restaurant chefs who make their living providing their discerning customers with 5 star grilled entrées. Their conclusion is that our OCI Pro Performance Grills provide exceptional searing power from the 14,000 BTU stainless steel main burners and

The Optional Sear Burner on all grills makes for a perfect grilling combination. We have also incorporated "zone grilling" into our line of OCI Grills. Each of our burner areas is sectioned off by a "heat separator" to provide the most efficient heat use of any grill on the market today. These removable stainless steel heat shields direct the heat upwards to the cooking surface and not outwards across the grill. The result is our OCI Pro-Performance grills are built to perform.



USING THE ROTISSERIE BURNER

Your Grill is capable of performing back burner Rotisserie cooking. The location of the rear burner allows the placement of a Rotisserie basting pan (not included) beneath the food to collect juices and drippings for basting and gravy. To flavor the contents of the basting pan, you can add herbs, onion, garlic, or spices. Hams are especially good with the addition of pineapple slices and brown sugar to the basting pan. Light the rear burner as described in the lighting instructions. Once lit, the Rotisserie burner will reach cooking temperatures in about 1 minute. The orange/red glow will even out in about 5 minutes. The Rotisserie motor is equipped with metal gears and is capable of turning up to a 15 lb. cut of meat or poultry. Make sure you remove the warming rack before use of Rotisserie.

WARNING: When using Rotisserie burner DO NOT use grill burners as this may cause injury or severe burns

The motor is mounted to a metal channel which attaches to the right / left side of the grill. The Rotisserie motor must be electrically grounded in accordance with local codes or, in the absence of local codes, with the National Electrical Code, ANSI/NFPA 70-1990. The skewer for the Rotisserie is assembled into the motor assembly by placing the pointed end into the motor, and resting the grooved bushing on the support at the opposite side of the grill. With the skewer pushed as far as possible into the motor, the skewer should rest on the opposite side of the grill body.

To load the skewer begin with the handle in place, and slide one of the meat holders (prongs facing away from the handle) onto the skewer. Push the skewer through the center of the food, then slide the second meat holder (prongs toward the food) onto the skewer. Center the product to be cooked on the skewer then push the meat holders firmly together. Tighten the wing nuts with pliers. It may also be necessary to wrap the food with butchers string (never use nylon or plastic string) to secure any loose portions. Once the food is secure insert the skewer into the motor. It is normal for the skewer to flex when larger cuts of meat are being cooked.

After your first use of the Rotisserie burner it is likely that the stainless steel adjacent to the burner will darken to a dark blue color. This is a normal property of the stainless steel used on the Grill and does not weaken the Metal.

WARNING: Keep the Rotisserie motor electric cord away from the heated surfaces of the grill. When not in use remove and store the motor in a dry location.

WARNING: Electrical Grounding Instructions this appliance (Rotisserie motor) is equipped with a three-prong (grounding) plug for your protection against shock hazard and should be plugged directly into a properly grounded three-prong receptacle. Do not cut or remove the grounding prong from this plug.



MANUAL LIGHTING:

To manually light the Rotisserie, place a butane lighter or long handled match near the tip of the thermo-Couple & Turn the control knob to “HI. Once lit, turn the control knob to desired setting. If the burner does not light within 4 seconds, release the safety valve button and turn the control knob to “OFF” and wait 5 minutes before trying again.

IMPORTANT SAFETY NOTICE:

Do NOT have the back burner on with the warming rack in place. Remove warming rack before you uses the Rotisserie burner.



NATURAL GAS CONNECTION:

The Gas grill will be clearly marked on the outer package NATURAL GAS and on the RATING PLATE located on the side of the BBQ. Please make sure that you DO NOT hook up the wrong Gas Type. All Gas Grills are pre-equipped with an approved Natural Gas Regulator preset – do Not change any settings unless you are converting the gas grill from one gas type to another. The diagram below will show you the approved hook up information and you must use a professional plumber or licensed gas installer to install and check the gas connection. IF YOU SMELL GAS immediately turn off gas to house and call the gas company to check the connections for leaks. If the BBQ is in a built in island, venting must be built into the island for safety.

LP GAS CONNECTION:

The gas grill will be clearly market as LP or Liquid Propane gas on the grill rating plate as well as the box. Refer to the below hook up information for the approved LP gas connection. Please note the Island MUST HAVE VENTING for LP gas and the absence of venting will have a potential for explosion if the gas builds up inside the island.

NOTE: never leave the gas on with the hood closed and the bbq not lit. this will allow the buildup of gas inside the bbq and island and when ignited will cause an explosion and equipment and bodily harm.

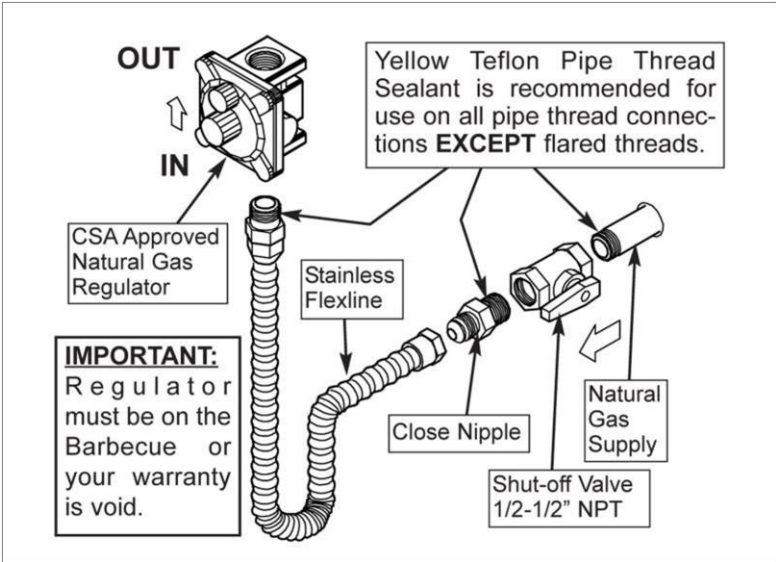
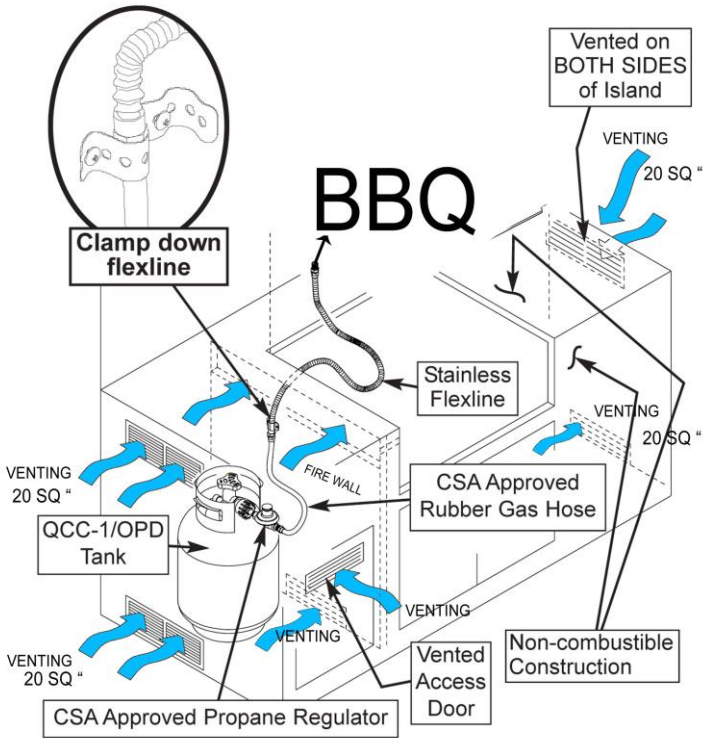

The self-contained LP system appliance is design certified to be used with a standard 20 lb., 12 1/4" diameter; 18" high cylinder with right handed connection threads and this is the maximum size LP tank to be used. The cylinder must be marked in accordance with the latest U.S. Department of Transportation specifications for LP gas cylinders. (DOT. CFR49 or National Standards of Canada CAN/CSA-B359 Cylinders, Spheres and Tubes for the Transportation of Dangerous Goods) a Propane Tank with an ODP) Overfill Prevention Device) must be used at all times.

IMPORTANT: Never connect the appliance to an unregulated gas supply.

The installation of this appliance must conform with local codes or in the absence of local codes, to the national fuel gas code, ANSI Z223.1a-1998. Installation in Canada must be in accordance with the standard CAN/CGA- B149.2, Propane Installation Code.

A licensed contractor or local gas company representative must perform all natural gas connections.

Ensure that the service supplying the appliance is fitted with a shut off valve conveniently positioned near the appliance and giving ease of access.

The appliance must be isolated from the gas supply piping system by closing its individual manual shutoff valve during any pressure testing of the gas supply piping system at test pressures equal to or less than 0.5 psi (3.5 kPa).

The appliance and its individual shutoff valve must be disconnected from the gas supply piping system during any pressure testing of that system at test pressure in excess of 0.5 psi (3.5 kPa).

Checking for Gas Leaks

Perform a leak test at least once a year whether the gas supply cylinder has been disconnected or not. In addition, whenever the gas cylinder is connected to the regulator or whenever any part of the gas system is disconnected or replaced, perform a leak test.

As a safety precaution, remember to always leak test your appliance outdoors in a well-ventilated area. Never smoke or permit sources of ignition in the area while doing a leak test. Do not use a flame, such as a lighted match to test for leaks. Use a solution of soapy water.

- Prepare a leak testing solution of soapy water by mixing in a spray bottle one part liquid soap to one part water.
- Make sure all the control knobs are in the OFF position.
- Turn on the gas
 - On Natural Gas systems, turn the main feed valve to the appliance.
 - On LP systems, turn the cylinder valve knob counter clockwise one turn to open.
- Apply the leak-testing solution by spraying it on joints of the gas delivery system.
- Blowing bubbles in the soap solution indicates that a leak is present.
- Stop a leak by tightening the loose joint resealing with thread sealant or Teflon tape, removing sealant or tape in the event of a flared connection or by replacing the faulty part with a replacement part recommended by the manufacturer. Do not attempt to repair the cylinder valve if it is damaged. The cylinder must be discarded to a proper LP tank location and then replaced.
- Turn all control knobs back to the full OFF position.
- If you are unable to stop a leak turn all control knobs back to the full OFF position, shut off the gas supply to the appliance and release pressure in the hose and manifold by pushing in and turning any of the control valves one quarter turn counter-clockwise.
- On LP systems, remove the cylinder from the appliance.
- Call an authorized gas appliance service technician or an LP gas dealer.
- Do not use the appliance until the leak is corrected.

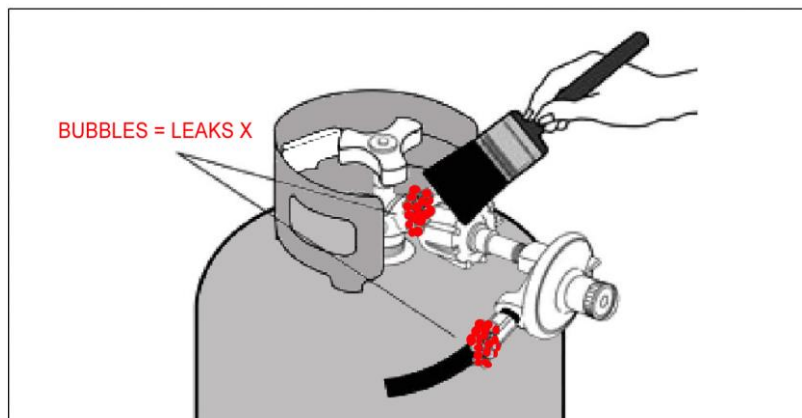

Leak Testing

All gas piping and connections must be tested for leaks after installation or service. All leaks must be corrected immediately. Remember-before exchanging an empty bottle for a new one; make sure all control valves are in the “off” position.

Open the valve (shut-off or ‘ON’ LP tank). Test for leaks by applying liquid soap solution to all joints. Bubbles forming indicate gas leak.

NEVER USE AN OPEN FLAME TO CHECK FOR LEAKS.

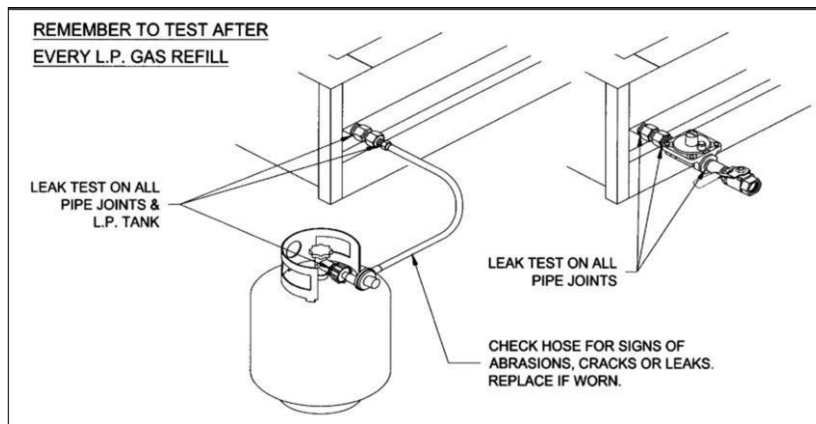



PRO-PERFORMANCE SERIES

BUILT IN CONSTRUCTION DETAILS

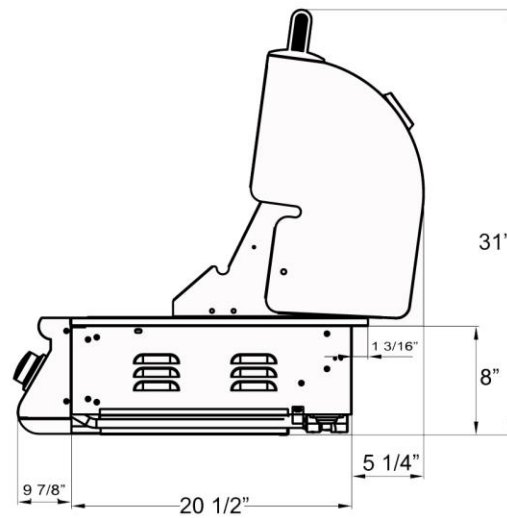
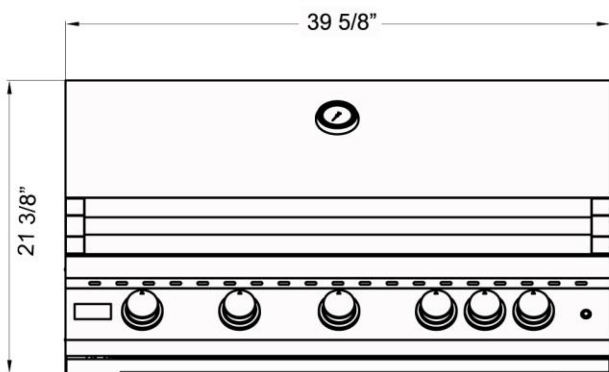
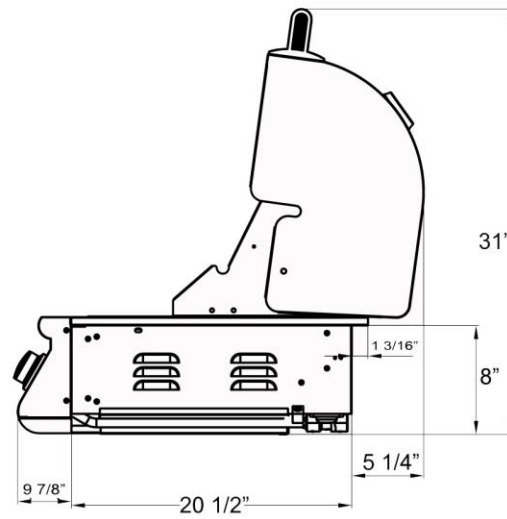
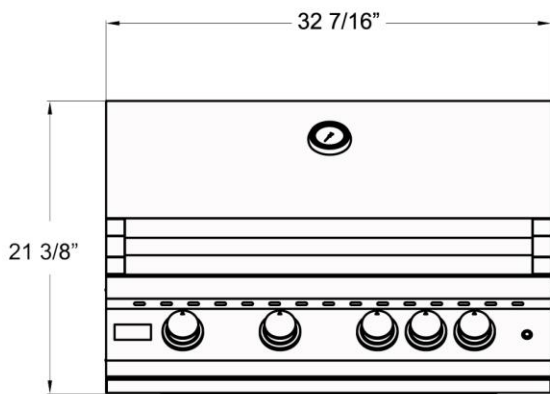
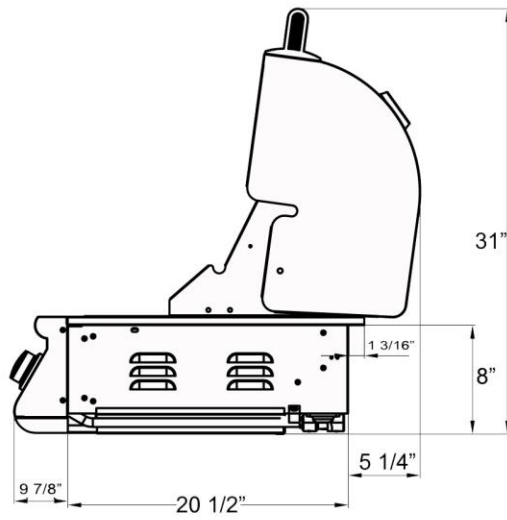
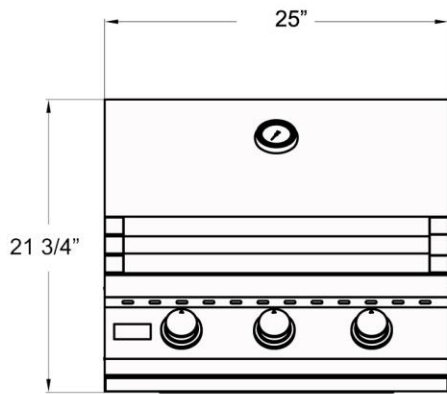

BUILT IN CONSTRUCTION DETAILS

Island must have venting on TOP and BOTTOM at least 20 SQ Inch on each vent.
 Collection of gas in the island is a potential explosive and fire hazard.

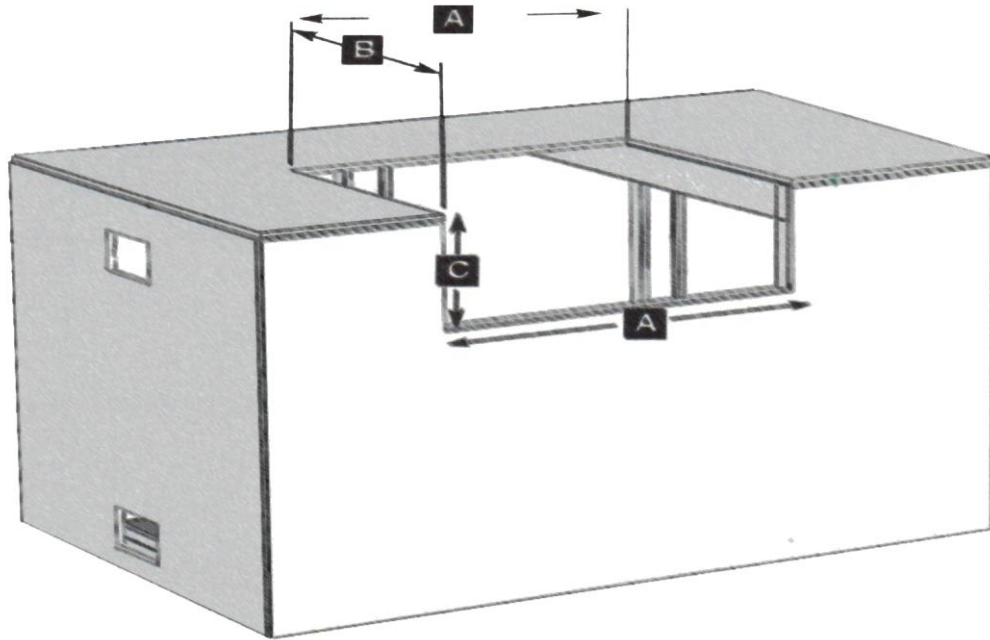

ISLANDS MUST BE MANUFACTURED FROM “NON-COMBUSTIBLE” MATERIAL.

Minimum clearance to adjacent combustible construction at 14” from sides & 16” from back

MODEL	DESCRIPTION	WIDTH (A)	DEPTH (B)	HEIGHT (C)
OCI-26BQP/BQN	25” 3 Burner	23 1/4”	21 1/4”	8 1/2”
OCI-32BQP/BQN	32” 4 Burner	30 5/8”	21 1/4”	8 1/2”
OCI-40BQP/BQN	40” 5 Burner	38 3/8”	21 1/4”	8 1/2”

Location:

When determining a suitable location take into account concerns such as exposure to wind, proximity to traffic paths and keeping any gas or electrical supply lines as short as possible.

Locate the grill only in a well-ventilated area. Never locate the grill in a building, garage, breezeway, shed or other such enclosed areas without an approved ventilation system. During heavy use, the grill will produce a lot of smoke. Ensure there is adequate area for it to dissipate.



CLEARANCE TO CONBUSTABLES

Clearances to Combustible Construction:

Above and below the cooking surface, maintain a minimum of 14” from the sides and a minimum of 16” from the back to adjacent vertical combustible construction.

Clearances to Non-combustible construction:

A minimum of 4” clearance from the back of the grill to non-combustible construction is required for lid to fully open. A minimum of 6” clearance from both sides is required for the Rotisserie motor and skewer handle.

NOTE FOR YOUR SAFETY:

This gas grill must NOT BE PLACED UNDER combustible material. A potential for fire could occur. Please always check with your local fire department as well as the local CITY and state codes for built in requirements.

CONVERSION FROM LP-NG / NG -LP

This Gas Grill is fully convertible from Liquid Propane Gas to Natural gas with the supplied Orifice changes. Please contact our company to get a certified manner of converting the grill. DO NOT attempt to convert the grill without consulting our company for a video link that will be sent to you. If you are not familiar with gas conversions please have a professional certified technician convert the gas grill for you using ONLY the provided OCI regulator and orifices. For NG to LP conversion you will require a QCC1 HOSE & REGULATOR and a LP tank. This can be purchased from your local Hardware store.

Please email: service@ociprogrill.com



GRILL RACK

The easiest way to clean the grill is immediately after cooking is completed and after turning off the flame. Wear a barbeque mitt to protect your hand from the heat and steam. Dip a brass bristle barbeque brush in tap water mixed with a small amount of vinegar and scrub the hot grill. Dip the brush frequently in the bowl of water. Steam, created as water contacts the hot grill, assists the cleaning process by softening any food particles. The food particles will fall and burn. If the grill is allowed to cool before cleaning, cleaning will be more difficult.

STAINLESS STEEL

The Grill is made from non-rusting and non-magnetic stainless steel. There are many different stainless steel cleaners available. Always use the mildest cleaning procedure first, scrubbing in the direction of the grain. To touch up noticeable scratches in the stainless steel, sand very lightly with dry 100 grit emery paper in the direction of the grain. Specks of grease can gather on the surfaces of the stainless steel and bake on to the surface and give the appearance of rust. For removal use an abrasive pad such as a scotch brite pad in conjunction with a stainless steel cleaner.

GRILL BURNERS

Extreme care should be taken when moving a burner as it must be correctly centered on the orifice before any attempt is made to relight the grill. Frequency of cleaning will depend on how often you use the grill. Ensure the gas supply is off and the knobs are in the “OFF” position. **Make sure the grill is cool.**

BURNER CLEANING

Clean the exterior of the burner with a wire brush. Clear stubborn scale with a metal scraper. Clear any clogged ports with a straightened paper clip. Never use a wooden toothpick as it may break off and clog the port. Shake out any debris through the air shutter. Use a flashlight to inspect the burner inlet to ensure it is not blocked. If obstructions can be seen, use a metal wire coat hanger that has been straightened out.

ORIFICE CLEANING

With the burner removed, remove the orifice and shine a flashlight through the openings to ensure there is no blockage. Use a needle to clear any debris. Be extremely careful not to enlarge the hole or break off the needle.

TO REASSEMBLE THE BURNERS:

Replace the burner by sliding the air shutter over the brass orifice, and insert burner tabs in burner mounts at rear.

IT IS EXTREMELY IMPORTANT TO CENTER THE BURNER ON THE ORIFICE PROPERLY.

Be careful not to upset the air shutters' original position (unless readjusting). Make sure it is level and does not rock. Replace the radiant trays, make sure that it sits level and does not rock. Light all of the burners and check for proper flame characteristics.



PRO-PERFORMANCE SERIES

TROUBLESHOOTING

PROBLEM

Grill won't light when the igniter knob is turned pressed.

WHAT TO DO

Remove the grill rack and the Briquette tray. Look down at the burner and turn the knob until you hear gas and NO CLICK. When you hear gas then continue to turn anticlockwise and you will hear click and flame will come out and light the burner.

If there is no flame when click . . . is there gas supplied to the unit and is the line purged of air? You can try and light with a LONG MATCH placed next to the burner

Do other burners on the unit operate?

Check the orifice for blockage like spider webs.

If you smell gas and still will not light call our 800 number for help

Burner flame is yellow or orange, in conjunction with the odor of gas.

Check the burner inlet for obstructions.

Check the air shutter for proper adjustment. .

Is the grill in a dusty area?

Low heat with knob in "HI" position.

Is the fuel hose bent or kinked?

Is there adequate gas supply available? If it is only one burner that appears low, does the orifice or burner need cleaning?

Is the air shutter too far open or closed?

Is the gas supply, or gas pressure low?

Is the grill being preheated for 15 minutes?

If L.P., is there gas in the tank?



PRO-PERFORMANCE SERIES

GRILLING HINTS & COOKING CHART

The doneness of meat, whether rare, medium, or well done, is affected to a large degree by the thickness of the cut. Expert chefs say it is impossible to have a rare doneness with a thin cut of meat. The cooking time is affected by the kind of meat, the size and shape of the cut, the temperature of the meat when cooking begins, and the degree of doneness desired.

When defrosting meats it is recommended that it be done overnight in the refrigerator as opposed to a microwave. This in general yields a juicier cut of meat. Use a spatula instead of tongs or a fork to turn the meat, as a spatula will not puncture the meat and let the juices run out. To get the juiciest meats, add seasoning or salt after the cooking is finished and turn the meat only once (juices are lost when the meat is turned several times). Turn the meat just after the juices begin to bubble to the surface. Trim any excess fat from the meat before cooking. To prevent steaks or chops from curling during cooking, slit the fat around the edges at 2-inch intervals.

DO NOT leave the grill unattended while cooking.

GRILL COOKING CHART:

FOOD	WEIGHT OR THICKNESS	FLAME SIZE	APPROXIMATE TIME	SPECIAL INSTRUCTIONS AND TIPS
VEGETABLES				
Fresh				
Beets Carrots Turnips		Medium	12 to 20 minutes	Slice. Dot with butter or margarine. Wrap in heavy duty foil. Grill, turning occasionally.
Onion	1/2 inch slices	Medium	8 to 20 minutes	Grill, turning once. Brush occasionally with melted butter or margarine.
Potatoes				
Sweet	Whole	Medium	40 to 60 minutes	Wrap individually in heavy-duty foil. Grill, rotating occasionally. Dot with butter or margarine.
White	6 to 8 ounces	High	45 to 60 minutes	Wrap in heavy-duty foil. Grill, turning occasionally.
Frozen				
Asparagus, Broccoli, Brussel Sprouts Green Beans, Peas		Medium	15 to 30 minutes	Place in aluminum foil pan. Grill, stirring occasionally.
French Fries		Medium	15 to 30 minutes	



PRO-PERFORMANCE SERIES

GRILL COOKING CHART

FOOD	WEIGHT OR THICKNESS	FLAME SIZE	APPROXIMATE TIME	SPECIAL INSTRUCTIONS AND TIPS
MEATS				
Pork Ham Steaks (precooked)	1/2 inch	High	4 to 8 minutes	Remove excess fat from edge. Slash remaining fat at 2-inch intervals. Grill, turning once.
Hot Dogs		Medium	5 to 10 minutes	Slit skin. Grill, turning once.
POULTRY				
Broiler/Fryer Halved or Quartered	2 to 3 pounds	Low or Medium	1 to 1-1/2 hours 40 to 60 minutes	Place skin side up. Grill, turning and brushing frequently with melted butter, margarine, oil or marinade.
Breasts		Medium	30 to 45 minutes	
FISH AND SEAFOOD				
Steaks Halibut, Salmon, Swordfish	3/4 to 1 inch	Medium to High	8 to 15 minutes	Grill, turning once. Brush with melted butter, margarine or oil to keep moist..
Whole Catfish Rainbow Trout	4 to 8 ounces	Medium to High	12 to 20 minutes	Grill, turning once. Brush with melted butter, margarine or oil.



PRO-PERFORMANCE SERIES

GRILL RECIPE SUGGESTIONS

BBQ SALMON

2 Large salmon steaks	2 Tbs. oil
Salt & pepper	2 Oz. Thin bacon slices
2 Tbs. butter	1 Tbs. lemon juice
Spring of parsley	Lemon wedges

Preheat the BBQ. Brush the steaks with oil and season with salt and pepper. Place on BBQ grill and cook for 10 minutes, turning steaks over halfway cooking time. Meanwhile fry the bacon in a pan on the side burner. Drain on paper towels. Melt the butter in a small saucepan taking care not to discolor it. Arrange the fish and bacon on serving plates. Pour the butter over and sprinkle with lemon juice. Garnish with parsley springs and lemon wedges.

Serve with boiled potatoes tossed in butter and sprinkled with chopped parsley and a crisp lettuce salad.

Note: Substitute catfish, halibut or cod for salmon.

PORK CHOPS

4 Pork chops	Marinade
1 Large onion	2 Tbs. Lemon juice or vinegar
2 Tbs. Oil	1/2 Tsp. Powdered mustard
2 Tsp. Worcestershire sauce	1/2 Tsp. Freshly ground black pepper
1 Tsp. Sugar	1/2 Tsp. Paprika
1 Clove garlic	

Peel, grate onion, add rest of the ingredients except the pork chops. Mix well. Pour over chops and marinate one hour in a cool place. Turn the BBQ grill on full. Heat 10 minutes. BBQ the chops brushing with the marinade occasionally. Serve with mixed salad, dressed with vinaigrette flavored with fresh dill.

BARBECUED LONDON BROIL

3/4 C. Italian dressing	1 Tsp. Worcestershire sauce
1 Tsp. dry mustard	1/4 Tsp. thyme, crushed
1 Medium onion, sliced	1 1/2 Pound flank steak, scored
2 Tbs. butter, melted	

Combine first 4 ingredients, add onion and marinate flank steak with it. Refrigerate at least 4 hours or overnight. Remove steak and grill on your preheated BBQ grill. Grill 5 to 7 minutes on each side basting frequently with the marinade. In the meantime sauté onions from the marinade in butter in a skillet on your side burner for 3 minutes. To serve, slice steak diagonally into thin slices, sprinkle onions over top. Garnish with vegetable kabobs.



PRO-PERFORMANCE SERIES

GRILL RECIPE SUGGESTIONS

BARBECUED POTATOES & CHEESE

1/2 Cups shredded cheddar cheese
1/3 Cup milk
1/4 Tsp. oregano
1/8 Tsp. pepper

1 Can (10 3/4 oz.) condensed cream of mushroom soup
2 Tbs. barbecue sauce
1/4 Tsp. salt
4 Cups thinly sliced potatoes (4 medium-sized potatoes)

Preheat grill. Combine cheese, condensed soup, milk, BBQ sauce, oregano, salt and pepper in a large mixing bowl. Stir in potatoes until well coated. Turn into well buttered 1 1/2 quart rectangular baking dish. Cover dish with aluminum foil. Bake covered 25 minutes on medium with the lid of your BBQ grill closed. Remove foil and continue baking 15 minutes longer or until potatoes are tender. Let stand 5 minutes before serving.

BEEF AND LAMB KABOBS

1/2 Lb. boneless sirloin or beef cut into 1" cubes
2/3 C. water, divided
2 Tbs. soy sauce
1 Tbs. dark brown sugar
2 cloves garlic, minced
1/4 Tsp. ground coriander
1/8 Tsp. ground red pepper
1 Red pepper cut into chunks
8 Small mushrooms

1/2 Lb. boneless loin of lamb cut into 1" cubes
1/4 C. chopped onion
1/4 C. vegetable oil, divided
1 Tbs. fresh lemon juice
1/4 Tsp. ground cumin
1/4 Tsp. ground turmeric
1/8 Tsp. ground ginger
1 Large banana, cut into chunks
1/3 C. smooth peanut butter

In blender, process 1/3 C. water, onion, soy sauce, 2 Tbsp. oil and the next 8 ingredients until smooth. Pour over meat cubes and marinate about 4 hours, turning occasionally. Drain and reserve marinade. Onto to four 12" skewers alternately thread meat, pepper, banana and mushrooms. Preheat grill. Brush the kabobs with oil. Grill 7-8 minutes each side. Bring marinade to boil on the side burner in a saucepan. Add remaining 1/3 C. water and peanut butter. Stir to blend. Heat through. If sauce gets too thick, add 1 Tbs. water. Serve sauce with kabobs.

TANGY SEAFOOD KABOBS

1 Lb. large shrimp, shelled & deveined
3/4 Lbs. sea scallops
1/4 C. cider vinegar
1 Tbs. vegetable oil
1/2 Tsp. prepared horseradish
1 20 Oz. can pineapple chunks in juice, drained

2/3 C. chili sauce
3 Tbs. chopped parsley
1 Tbs. Worcestershire sauce
1 Clove garlic, minced

In medium bowl, combine shrimp and scallops. In small bowl combine chili sauce and next six ingredients. Pour over seafood. Toss to coat. Cover, refrigerate 2 hours. Half hour before cooking, turn the burner to the grill on full. Drain seafood reserving marinade. On each of twelve 10" skewers, thread 2 shrimps and 2 scallops, alternating with pineapple chunks. Place skewers on grill. Cook 7-10 minutes, often basting and turning.



PRO- PERFORMANCE SERIES

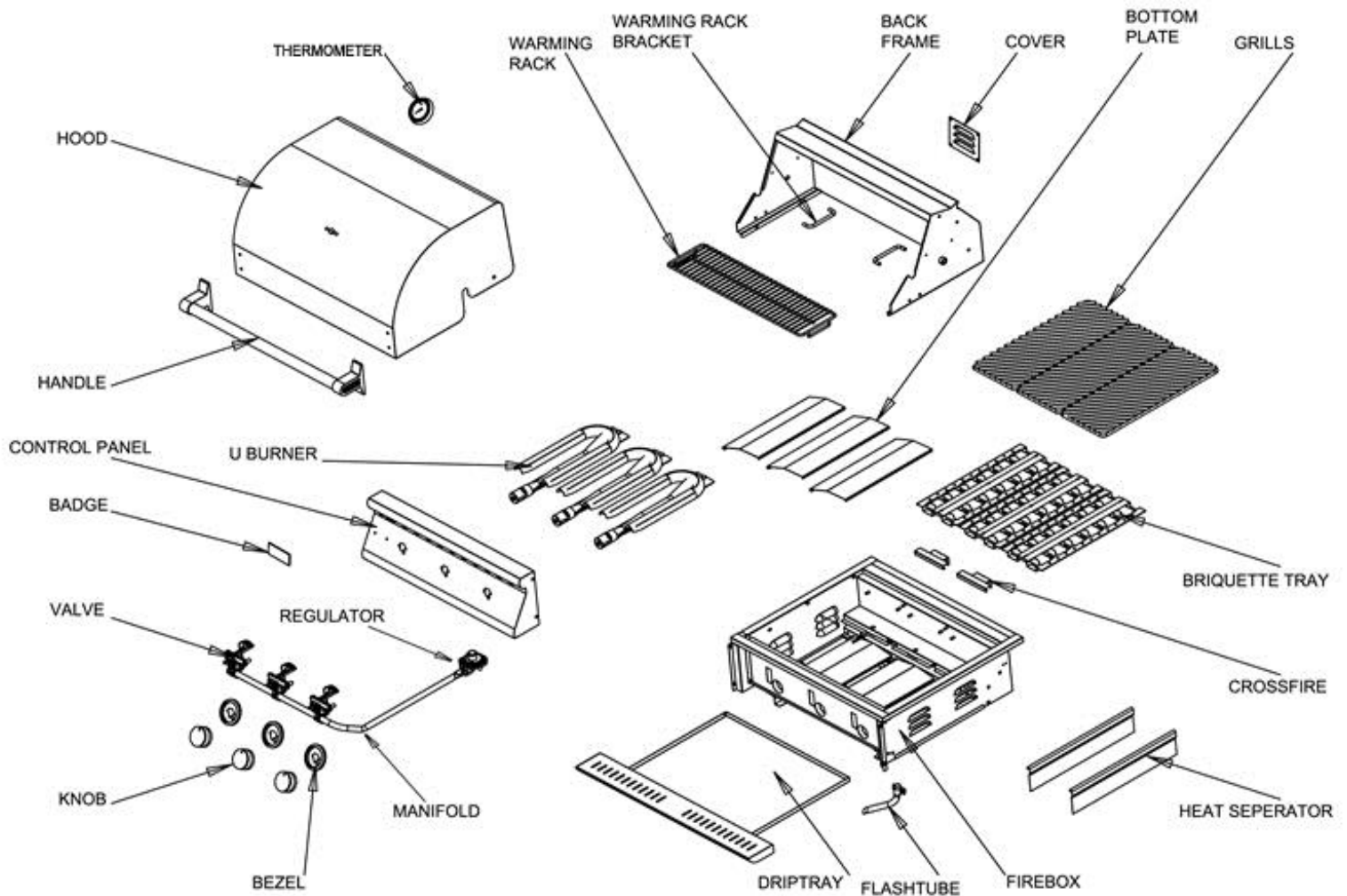

PART #	3 BURNER	DESCRIPTION	QTY	OCI-024	FLASHTUBE	2
OCI-001		HOOD	1	OCI-025	FIREBOX	1
OCI-004		HANDLE	1	OCI-028	HEAT SEPERATOR	3
OCI-007		CONTROL PANEL	1	OCI-029	CROSSFIRE	2
OCI-010		BADGE	1	OCI-030	BRIQUETTE TRAY	3
OCI-011 / OCI-012		MAIN / REAR BNR VALVE	3	OCI-031	GRILLS	3
OCI-013		LP /NG REGULATOR	1	OCI-032	BOTTOM PLATE	3
OCI-014		U BURNER	3	OCI-033	COVER	1
OCI-015 / OCI-016		MAIN / REAR BNR KNOB	3	OCI-034	BACK FRAME	1
OCI-017		BEZEL	3	OCI-037	WARMING RACK BRACKET	2
OCI-018		MANIFOLD	1	OCI-038	WARMING RACK	1
OCI-021		DRIPTRAY	1	OCI-041	THERMOMETER	1



PRO-PERFORMANCE SERIES

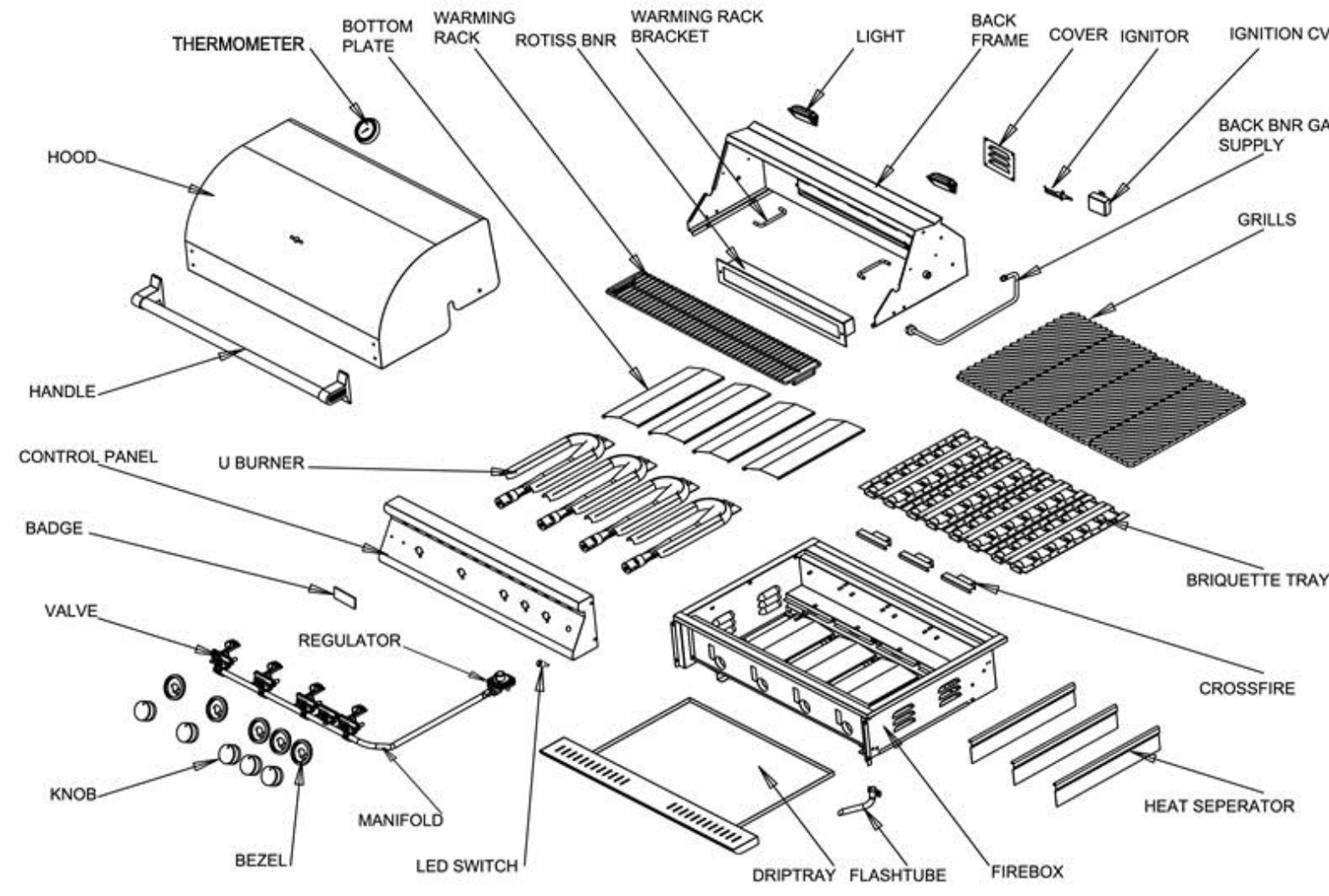

PART #	4 BURNER	DESCRIPTION	QTY	OCI-024	FLASHTUBE	2
OCI-002		HOOD	1	OCI-026	FIREBOX	1
OCI-005		HANDLE	1	OCI-028	HEAT SEPERATOR	4
OCI-008		CONTROL PANEL	1	OCI-029	CROSSFIRE	2
OCI-010		BADGE	1	OCI-030	BRIQUETTE TRAY	4
OCI-011 / OCI-012		MAIN / REAR BNR VALVE	4	OCI-031	GRILLS	4
OCI-013		LP /NG REGULATOR	1	OCI-032	BOTTOM PLATE	4
OCI-014		U BURNER	4	OCI-033	COVER	1
OCI-015 / OCI-016		MAIN / REAR BNR KNOB	4	OCI-035	BACK FRAME	1
OCI-017		BEZEL	4	OCI-037	WARMING RACK BRACKET	2
OCI-019		MANIFOLD	1	OCI-039	WARMING RACK	1
OCI-022		DRIPTRAY	1	OCI-041	THERMOMETER	1



PRO- PERFORMANCE SERIES

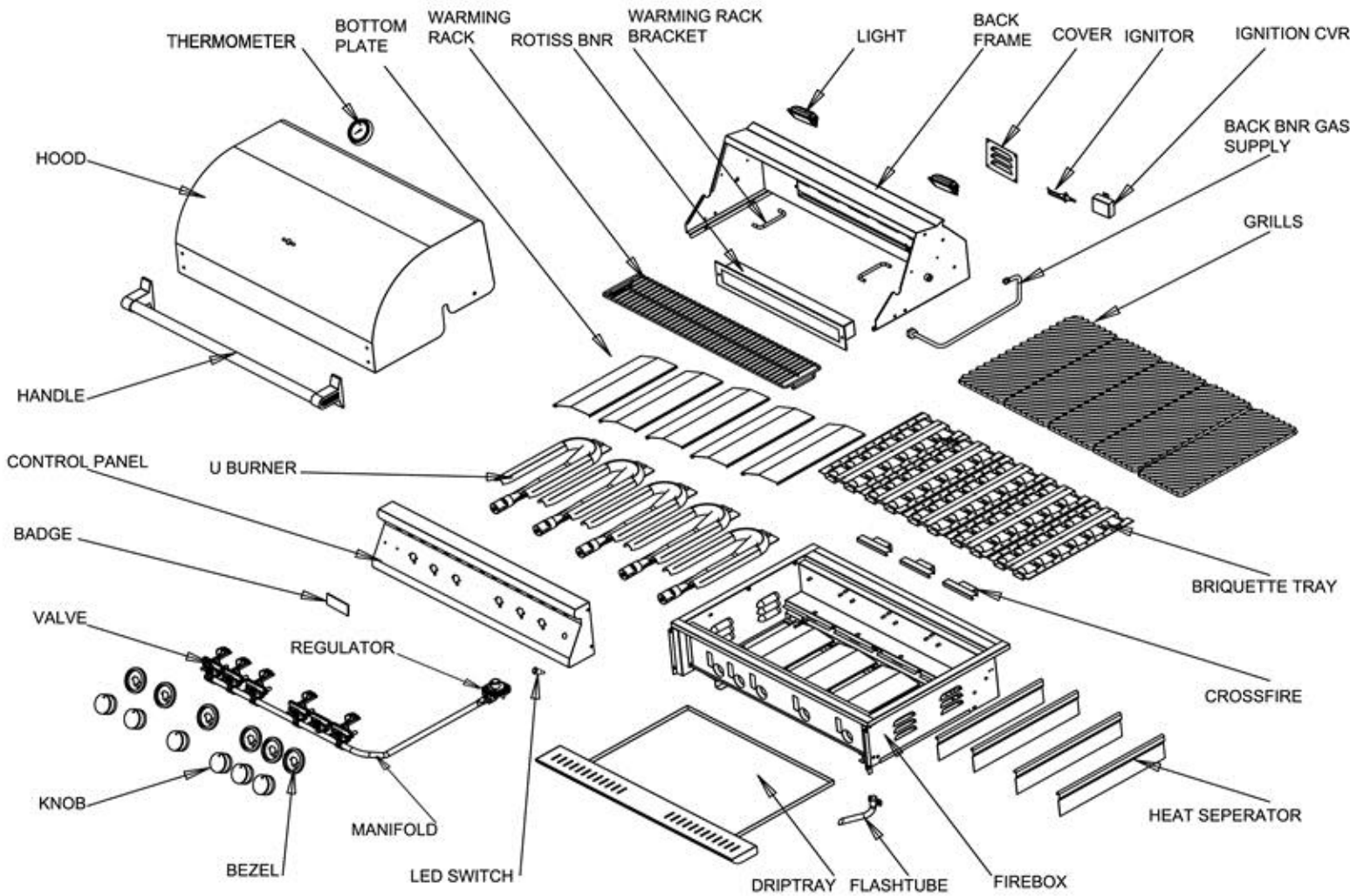

PART #	DESCRIPTION	QTY	PART #	DESCRIPTION	QTY
OCI-003	HOOD	1	OCI-024	FLASHTUBE	2
OCI-006	HANDLE	1	OCI-027	FIREBOX	1
OCI-009	CONTROL PANEL	1	OCI-028	HEAT SEPERATOR	5
OCI-010	BADGE	1	OCI-029	CROSSFIRE	2
OCI-011 / OCI-012	MAIN / REAR BNR VALVE	5	OCI-030	BURIQUETTE TRAY	5
OCI-013	LP /NG REGULATOR	1	OCI-031	GRILLS	5
OCI-014	U BURNER	5	OCI-032	BOTTOM PLATE	5
OCI-015 / OCI-016	MAIN / REAR BNR KNOB	5	OCI-033	COVER	1
OCI-017	BEZEL	5	OCI-036	BACK FRAME	1
OCI-020	MANIFOLD	1	OCI-037	WARMING RACK BRACKET	2
OCI-023	DRIPTRAY	1	OCI-040	WARMING RACK	1
			OCI-041	THERMOMETER	1



PRO-PERFORMANCE SERIES

Length of Warranty On Stainless Steel Grill:

One (1) Year Full parts Covers the entire product **One (1) Year** Full parts Covers the entire product

Five (5) Year comprehensive warranty covering the Stainless Steel grates, assemblies, and drip pans. Should structural deterioration occur to the degree of non-performance, a replacement will be furnished (**excluding discoloration or surface corrosion**).

Limited Lifetime Warranty on all stainless steel components (excluding discoloration or surface corrosion)

OCI Will Pay For

All repair labor and parts found to be defective due to materials or workmanship for one full year from date of purchase. This does not apply if the unit was subjected to other than normal household use. Service must be provided by Authorized Factory Agent during normal working hours. No charges will be made for repair or replacement at the location of initial installation or factory for parts returned pre-paid, through the dealer and claimed within the warranty period, and found by Outdoor Concepts to be defective.

Replacement will be F.O.B. OCI, and OCI will not be liable for any transportation costs, labor costs, or export duties. This warranty shall not apply, nor can we assume responsibility for damage that might result from failure to follow manufacturer's instructions or local codes, where the appliance has been tampered with or altered in anyway or which, in our judgment, has been subjected to misuse, negligence, or accident. Implied warranty shall not extend beyond the duration of this written warranty. This warranty is in lieu of all warranties expressed or implied and all other obligations or liability in connection with the sale of this appliance.

OCI Will Not Pay For

Installation or start-up. Shipping costs. Shipping damage.

Service by an unauthorized agency.

Damage or repairs due to service by an unauthorized agency or the use of unauthorized parts.

Service during other than normal working hours.

Improper installation, such as improper hook-up, etc.

Service visits to teach you how to use the appliance; correct the installation; reset circuit breakers or replace home fuses.

Repairs due to other than normal household use.

Repairs due to Commercial usage.

Damage caused from accident, abuse, alteration, misuse, incorrect installation or installation not in accordance with local codes. Units installed in non-residential application such as day care centers, bed and breakfast centers, churches, nursing homes, restaurants, hotels, schools, catering etc.

This warranty applies to appliances used in residential applications; it does not cover their use in commercial situations. This warranty is for products purchased and retained in the 50 states of the U.S.A., the District of Columbia and Canada. This warranty applies even if you should move during the warranty period. This warranty applies only to the original purchaser. This warranty gives you specific legal rights. You may also have other rights which vary from state to state.

NOTE: Stainless Steel will discolor due to Heat. Pool Chemicals will affect the Stainless Steel Like Chlorine and other corrosive chemicals. NEVER STORE CHEMICALS NEAR BBQ – THEY WILL CORRODE GAS LINES.



PRO- PERFORMANCE SERIES

Our Customers are our first priority please call or email

1-888-419-0888

support@ociprogrill.com

As product improvement is an ongoing process, we reserve the right to change specifications without notice