

This Owner's Manual is provided and hosted by [Appliance Factory Parts](#).



Napoleon GDS60-1P Owner's Manual

[Shop genuine replacement parts for Napoleon
GDS60-1P](#)



[Find Your Napoleon Fireplace Parts - Select From 171 Models](#)

----- Manual continues below -----

KNIGHTSBRIDGE™ DIRECT VENT GAS STOVE

Specifications

Model	BTU (NG)	BTU (LP)	BTU (Rear Vent)	Width	Height	Depth	Glass
GDS60	35,000	31,500	21,000	27	30 1/2	19 1/2	18 3/4 X 21

Overview

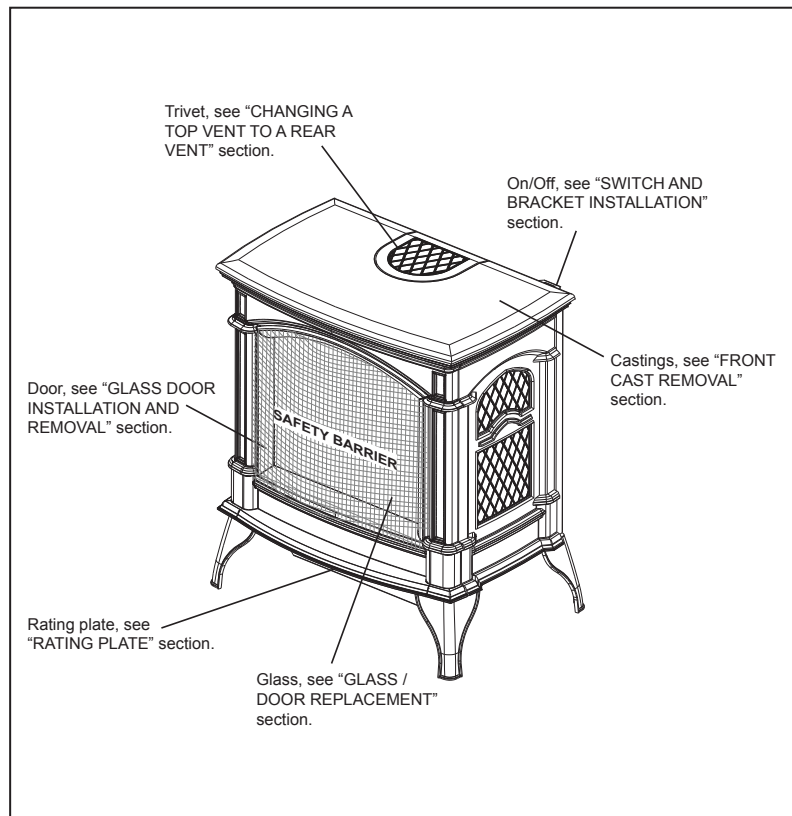

Dimensions

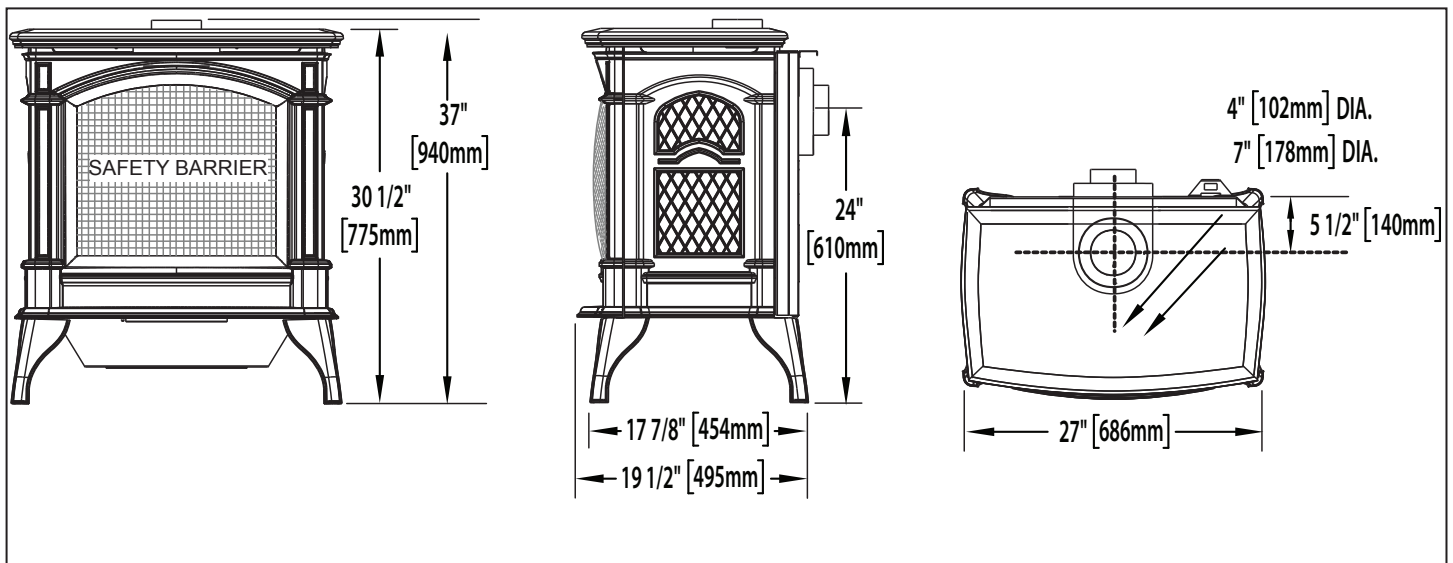

KNIGHTSBRIDGE™ DIRECT VENT GAS STOVE

Clearances

Vent Terminal Clearances

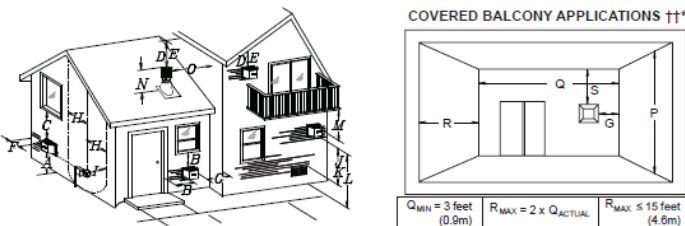

INSTALLATIONS		Clearance	
CANADA	U.S.A.		
A	12" (305mm)	12" (305mm)	Clearance above grade, veranda porch, deck or balcony.
B	12" (305mm) [†]	9" (229mm) [†]	Clearance to windows or doors that open.
C	12" (305mm) [*]	12" (305mm) [*]	Clearance to permanently closed windows.
D	18" (457mm) ^{**}	18" (457mm) ^{**}	Vertical clearance to ventilated soffits located above the terminal within a horizontal distance of 2' (0.6m) from the center line of the terminal.
E	12" (305mm) ^{***}	12" (305mm) ^{***}	Clearance to unventilated soffit.
F	0" (0mm)	0" (0mm)	Clearance to an outside corner wall.
G	0" (0mm) ^{****}	0" (0mm) ^{****}	Clearance to an inside non-combustible corner wall or protruding non-combustible obstructions (chimney, etc.).
	2" (51mm) ^{****}	2" (51mm) ^{****}	Clearance to an inside combustible corner wall or protruding combustible obstructions (vent chase, etc.).
H	3' (0.9m)	3' (0.9m) ^{*****}	Clearance to each side of the center line extended above the meter / regulator assembly to a maximum vertical distance of 15' (4.6m).
I	3' (0.9m)	3' (0.9m) ^{*****}	Clearance to a service regulator vent outlet.
J	12" (305mm)	9" (229mm)	Clearance to a non-mechanical air supply inlet to the building or a combustion air inlet to any other appliance.
K	6" (1.8m)	3' (0.9m) †	Clearance to a mechanical air supply inlet.
L	7" (2.1m) ‡	7" (2.1m) ****	Clearance above a paved sidewalk or paved driveway located on public property.
M	12" (305mm) ††	12" (305mm) ****	Clearance under a veranda, porch or deck.
N	16" (406mm)	16" (406mm)	Clearance above the roof.
O	2' (0.6m) ††	2' (0.6m) ††	Clearance from an adjacent wall including neighbouring buildings.
P	8' (2.4m)	8' (2.4m)	Roof must be non-combustible without openings.
Q	3' (0.9m)	3' (0.9m)	See chart for wider wall dimensions.
R	6" (1.8m)	6" (1.8m)	See chart for deeper wall dimensions. The terminal shall not be installed on any wall that has an opening between the terminal and the open side of the structure.
S	12" (305mm)	12" (305mm)	Clearance under a covered balcony

[†] The terminal shall not be located less than 6 feet under a window that opens on a horizontal plane in a structure with three walls and a roof.
^{*} Recommended to prevent condensation on windows and thermal breakage.
^{**} It is recommended to use a heat shield and to maximize the distance to vinyl clad soffits.
^{***} The periscope requires a minimum 18 inches clearance from an inside corner.
^{****} This is a recommended distance. For additional requirements check local codes.
^{*****} 3 feet above if within 10 feet horizontally.
^{††} A vent shall not terminate where it may cause hazardous frost or ice accumulations on adjacent property surfaces.
[‡] Permitted only if the veranda, porch, or deck is fully open on a minimum of two sides beneath the floor.
^{†††} Recommended to prevent recirculation of exhaust products. For additional requirements check local codes.
^{††††} Permitted only if the balcony is fully open on a minimum of one side.

NOTE: Clearances are in accordance with local installation codes and the requirements of the gas supplier.

Minimum Clearance To Combustibles

MAINTAIN THESE MINIMUM CLEARANCES TO COMBUSTIBLES:
 A. 6" (152mm) B. 6" (152mm) C. 2" (51mm)^{*}

Minimum 20" (508mm) from appliance top to ceiling.
 8" (152.4mm) to single wall connector.

^{*}At a distance of 2" (51mm) from the wall, access to the blower switch, on-off switch or the blower power cord may not be practical.

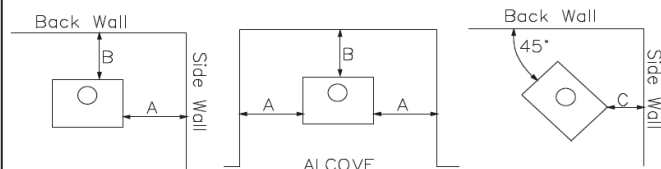

Venting Flow Chart

TOP EXIT			
Horizontal Termination		Vertical Termination	
Vertical rise is equal to or greater than the horizontal run	Vertical rise is less than horizontal run	Vertical rise is equal to or greater than the horizontal run	Vertical rise is less than horizontal run
Horizontal run + vertical rise to maximum of 40 feet (12m)	Horizontal run + vertical rise to maximum of 24.75 feet (7.5m)	Horizontal run + vertical rise to maximum of 40 feet (12m)	Horizontal run + vertical rise to maximum of 40 feet (12m)
	4.2 times the vertical rise equal to or greater than the horizontal run		3 times the vertical rise equal to or greater than the horizontal run

13.1A

REAR EXIT			
Horizontal Termination		Vertical Termination	
Vertical rise is equal to or greater than the horizontal run	Vertical rise is less than horizontal run	Vertical rise is equal to or greater than the horizontal run	Vertical rise is less than horizontal run
Horizontal run + vertical rise to maximum of 40 feet (12m)	Horizontal run + vertical rise to maximum of 24.75 feet (7.5m)	Horizontal run + vertical rise to maximum of 40 feet (12m)	Horizontal run + vertical rise to maximum of 40 feet (12m)
	3.5 times the vertical rise equal to or greater than the horizontal run		3 times the vertical rise equal to or greater than the horizontal run

Product information provided is not complete and is subject to change without notice. Please consult the installation manual for the most up to date installation information.