

This Owner's Manual is provided and hosted by [Appliance Factory Parts](#).



Bull 97008 Owner's Manual

[Shop genuine replacement parts for Bull 97008](#)



[Find Your Bull Grill Parts - Select From 35 Models](#)

----- Manual continues below -----



ASSEMBLY & OPERATING INSTRUCTIONS

MODEL #97008 GRIDDLE, BUILT-IN, L.P. (PROPANE)

MODEL #97009 GRIDDLE, BUILT-IN, N.G. (NATURAL GAS)

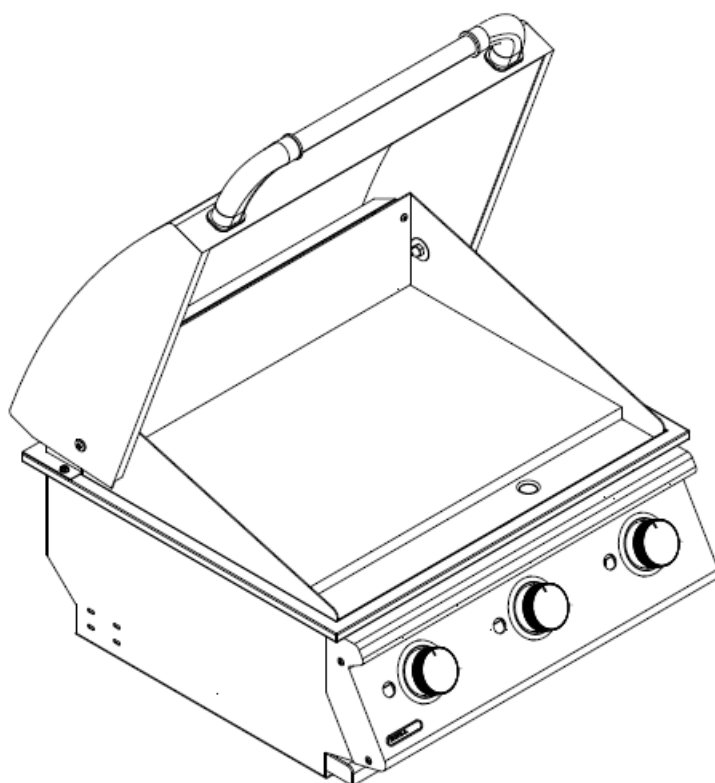

TABLE OF CONTENTS

PAGE #

SAFETY INSTRUCTIONS	2
<i>THE LOCATION FOR YOUR GRIDDLE</i>	2
<i>CHECKING FOR GAS LEAKS</i>	2
<i>NATURAL GAS SAFETY</i>	3
<i>PROPANE GAS SAFETY</i>	4
INSTALLATION INSTRUCTIONS	5
<i>SPECIFICATIONS FOR GRIDDLE STRUCTURE</i>	5
<i>CONNECTING TO GAS SOURCE</i>	6
<i>NATURAL GAS CONNECTIONS</i>	6
<i>PROPANE GAS CONNECTIONS</i>	6
<i>OUTDOOR NATURAL GAS GRIDDLE INSTALLATION SPECIFICATIONS</i>	7
<i>OUTDOOR PROPANE GAS GRIDDLE INSTALLATION SPECIFICATIONS</i>	8
<i>LP GAS TANK RETENTION</i>	9
INSPECTING / CLEANING BURNERS AND GAS VALVE ORIFICES	10
<i>BURNER CLEANING</i>	10
<i>BURNER SHUTTER CLIP INSPECTION / ADJUSTMENT</i>	12
<i>BURNER REPLACEMENT INTO INSERT</i>	13
<i>IGNITOR / ELECTRODE CHECK</i>	13
<i>BURNER OPERATION CHECK</i>	13
<i>FLEX LINE AND REGULATOR PLACEMENT</i>	15
LIGHTING & OPERATING INSTRUCTIONS	16
<i>LIGHTING PROCEDURES</i>	16
<i>OPERATING PROCEDURE</i>	16
CLEANING & MAINTENANCE	17
TROUBLESHOOTING	18
<i>IF GRIDDLE FAILS TO OPERATE PROPERLY</i>	18
<i>YELLOW FLAME</i>	19
<i>FLASH BACK</i>	19
LOCATIONS OF SERIAL NUMBER	20
PARTS LIST	21
EXPLODED ILLUSTRATION	22
LIMITED WARRANTY	23
<i>REGISTERING YOUR GRIDDLE</i>	23

- READ THE FOLLOWING INSTRUCTIONS CAREFULLY AND BE SURE YOUR GRIDDLE IS PROPERLY INSTALLED, ASSEMBLED AND CARED FOR. FAILURE TO FOLLOW THESE INSTRUCTIONS MAY RESULT IN SERIOUS BODILY INJURY AND/OR PROPERTY DAMAGE. IF YOU HAVE QUESTIONS CONCERNING ASSEMBLY OR OPERATION, CONSULT YOUR DEALER, GAS APPLIANCE SERVICE REPRESENTATIVE OR YOUR GAS COMPANY.

- NOTE TO INSTALLER:

LEAVE THESE INSTRUCTIONS WITH THE CONSUMER AFTER INSTALLATION.

- NOTE TO THE CONSUMER:

RETAIN THESE INSTRUCTIONS FOR FUTURE REFERENCE.

- THIS OUTDOOR COOKING GAS APPLIANCE IS NOT INTENDED TO BE INSTALLED IN OR ON RECREATIONAL VEHICLES AND/OR BOATS.

*FOR WARRANTY PURPOSES, PLEASE RECORD YOUR MODEL NUMBER, SERIAL NUMBER, DATE OF PURCHASE & A COPY OF YOUR RECEIPT OR INVOICE IN THE BACK OF YOUR MANUAL ON PAGE 23.



SAFETY INSTRUCTIONS

READ CAREFULLY BEFORE ASSEMBLY AND OPERATION OF YOUR GRIDDLE

This gas griddle must be installed in accordance with local codes or, if in an area without local codes, with the latest edition of the National Fuel Gas Code ANSI Z223.1. In Canada, installation must conform to the standard CAN/CGA 1-b149.1 and/or .2 (Installation Code for Gas Burning Appliances and Equipment) and any local codes.

WARNING: Fuels used in gas or oil-fired appliances and the products of combustion of such fuels, contain chemicals known to the State of California to cause cancer, birth defects and/or reproductive harm. This warning is issued pursuant to California Health & Safety Code Sec. 25249.6.

THE LOCATION FOR YOUR GRIDDLE

DO NOT use your gas griddle in garages, porches, breezeways, sheds or other enclosed areas. Your gas griddle is to be used **OUTDOORS ONLY**, with at least **21 inches** clearance from the back and side of any combustible surface. The griddle should not be placed under or on top of any surface that will burn. Do not obstruct the flow of combustion and ventilation air around the griddle housing.

PROTECT CHILDREN: Keep children away from the griddle during use and until the griddle has cooled after you are finished. Do not allow children to operate the griddle.

WARNING! FOR YOUR SAFETY...

- **DO NOT store or use gasoline or other flammable vapors and liquids in the vicinity of this or any other appliance.**
- **DO NOT store empty or full spare gas cylinders and/or chemicals under or near this or any other appliance.**
- **Keep the fuel hose away from hot surfaces. Protect the fuel hose from dripping grease. Avoid unnecessary twisting of the hose. Visually inspect the hose prior to each use for cuts, cracks excessive wear or other damage and replace if necessary.**
- **NEVER test for gas leaks with a lighted match or open flame.**
- **NEVER light griddle with lid closed or before checking to ensure burner tubes are fully seated over gas valve orifices.**
- **NEVER lean over cooking surface while lighting griddle. Use barbecue tools with wood handles and good quality insulated oven mitts when operating griddle.**

DANGER! IF YOU SMELL GAS...

1. **Shutoff gas to the appliance at its' source.**
2. **Extinguish any open flame.**
3. **Open griddle lid to release any accumulation of fumes.**
4. **If gas odor persists, immediately contact your gas supplier or your fire department.**

CHECKING FOR GAS LEAKS

NEVER TEST FOR GAS LEAKS WHILE THE GRIDDLE IS LIT! Prior to the first use and at the beginning of each new season (or, if using LP, whenever gas cylinder is changed), it is a must that you check for gas leaks. Follow these steps:

1. Make a soap solution by mixing one part liquid detergent and one part water.
2. Turn off heat control valve(s), and then turn on gas at source.
3. Apply the soap solution to all gas connections: bubbles will appear in the soap solution if connections are not properly sealed. Tighten or repair as necessary.
4. If you have a gas leak that you cannot repair, turn off the gas at the source, disconnect fuel line from the griddle and immediately call your griddle dealer and gas supplier for professional assistance.



SAFETY INSTRUCTIONS (CONT.)

NATURAL GAS SAFETY

Your Natural Gas griddle is designed to operate on natural gas ONLY, at a pressure of 4" water column (W.C.) regulated at the natural gas regulator attached at the back of the griddle. Check with your gas utility for local gas pressure and with your local municipality for building code requirements.

Check with your gas utility or with local building codes for instructions to install gas supply line, or call a licensed and knowledgeable installer.

It is recommended that an "ON-OFF" shutoff valve be installed at the gas supply source:

- Outdoors after gas line piping exits outside wall or before gas line piping enters ground.
- Indoors in the branch fuel line in an accessible location near the supply line.

Pipe sealing compound or pipe thread tape of the type resistant to the action of natural gas must be used on all male pipe thread. Apply compound or tape to at least the first three threads when making the connection.

Disconnect your gas griddle from fuel source when the gas supply is being tested at high pressures. This appliance and its individual shutoff valve must be disconnected from the gas supply piping system during any pressure testing of that system at pressures in excess of 1/2 psig (3.5 kPa).

Turn off your gas griddle when the gas supply is being tested at low pressures. This appliance must be isolated from the gas supply piping system by closing its individual valve.

WARNING: Gas valves are preset at the factory to operate on LP or natural gas. If you wish to convert to a different gas type, be sure to contact your griddle dealer, licensed plumber or authorized service center for further details. Conversion kits are not sold to the general public and require a professional to perform service. Failure to properly convert a unit can cause serious injury to yourself and/or others, irreparable damage to your griddle and void of warranty.

SAFETY!

BEWARE OF SPIDERS



CAUTION: BURNERS MUST BE INSPECTED AND CLEANED BEFORE FIRST USE.

Spiders and small insects occasionally spin webs or make nests in the burners during warehousing, transit and/or after long periods of non-use. These webs can lead to a gas flow obstruction, which could result in a fire in and around the burner tubes. This type of fire is known as "FLASH-BACK" and can cause serious damage to your griddle and create an unsafe operating condition for the user. Although an obstructed burner tube is not the only cause of "FLASH BACK" it is the most common cause, and frequent inspection and cleaning of the burners is necessary.



SAFETY INSTRUCTIONS (CONT.)

PROPANE GAS SAFETY

Your Propane gas griddle is designed to operate on propane gas ONLY, at a pressure regulated at 11" water column (W.C.) when equipped with the correct propane orifices on the valves and a propane regulator on the supply line regulated at the residential meter.

Your propane gas griddle is designed to be used with a standard 20 lb gas cylinder. In the United States, the gas cylinder must be constructed and marked in accordance with specifications of the US Department of Transportation for Propane Gas Cylinders.

Always keep cylinder securely fastened in an upright position.

Never connect an unregulated propane gas cylinder to the griddle.

Do not subject Propane cylinders to excessive heat.

CAUTION: Never store a Propane gas cylinder inside a building or in the vicinity of any gas-burning appliance.

WARNING: Gas valves are preset at the factory to operate on LP or natural gas. If you wish to convert to a different gas type, be sure to contact your griddle dealer, licensed plumber or authorized service center for further details. Conversion kits are not sold to the general public and require a professional to perform service. Failure to properly convert a unit can cause serious injury to yourself and/or others, irreparable damage to your griddle and void of warranty.

SAFETY!

BEWARE OF SPIDERS



CAUTION: BURNERS MUST BE INSPECTED AND CLEANED BEFORE FIRST USE.

Spiders and small insects occasionally spin webs or make nests in the burners during warehousing, transit and/or after long periods of non-use. These webs can lead to a gas flow obstruction, which could result in a fire in and around the burner tubes. This type of fire is known as "FLASH-BACK" and can cause serious damage to your griddle and create an unsafe operating condition for the user. Although an obstructed burner tube is not the only cause of "FLASH BACK" it is the most common cause, and frequent inspection and cleaning of the burners is necessary.

WARNING

- **Do not store a spare or disconnected liquid propane cylinder under or near this appliance.**
- **A dented or rusty liquid propane cylinder may be hazardous and should be check by your liquid propane provider.**
- **Do not use a liquid propane cylinder with a damaged valve.**



INSTALLATION INSTRUCTIONS

PLEASE READ THESE INSTRUCTIONS BEFORE INSTALLING YOUR GAS GRIDDLE

Your built-in gas griddle comes to you fully assembled. We strongly recommend professional installation and hookup of the gas griddle. These instructions will provide you with the measurements necessary for you or your builder to construct a masonry structure to house your outdoor gas griddle.

NOTE TO INSTALLER: Leave these instructions with the consumer for future reference. The griddle must be installed in accordance with all local building codes.

NOTE: Please remove the cotter pins from the burners before installing unit into an island. See page 12 for cotter pin removal.

SPECIFICATIONS FOR BARBECUE STRUCTURE

1. Your choice of masonry can be used for cabinet construction for the built-in gas griddle; however it must be **non-combustible** material. Keep in mind when choosing a location for your griddle that it should NOT be located under any overhead combustible construction. Upper and lower level vents must be provided for combustion air on both sides of built-in cabinet. Vents on griddle insert must remain unobstructed to allow for combustion air and ventilation. Upper vents must be located within 5 inches from the top of the island enclosure to the bottom of the vent. Lower vents must be located within 1 inch from the bottom of the island enclosure to the bottom of the first vent openings and no more than 5 inches from the bottom of the island enclosure to the top of the vent. If not using Bull vents, the vents you use must meet ANSI Standard codes. The upper vents must have openings that have a total free area of not less than 1 sq in per lb of stored fuel capacity per vent and the lower vents must have openings that have a total free area of not less than 1/2 sq in per lb of stored fuel capacity per vent. Both upper and lower vent openings must have minimum dimensions so as to permit the entrance of a 1/8 in diameter rod.

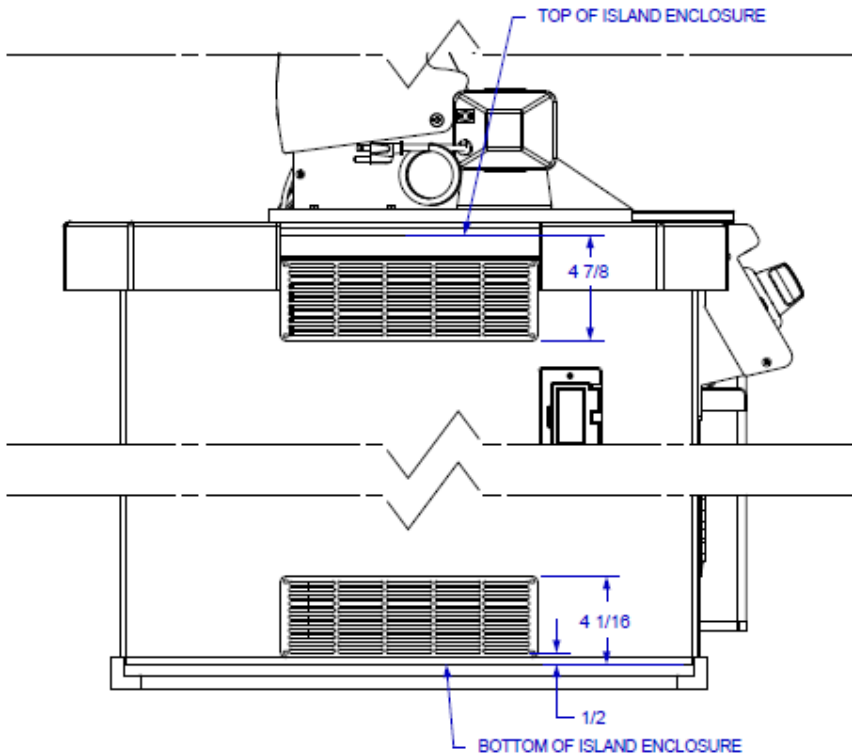

2. The griddle requires a wall opening of the following dimensions: **See PAGES 7 & 8 for different models.**

3. Place gas griddle assembly into wall opening as shown in illustration on pages 7 & 8. Griddle rests on side and back edges of the griddle insert.

4. **For propane gas LP TANK STORAGE AREA MUST BE ISOLATED FROM GRIDDLE AND VENTED.**

5. Do not use any combustible materials for this construction. Minimum horizontal clearance to adjacent combustible surface from side and back of the griddle must be **21 inches**. A 6 inch clearance is required behind griddle to allow front portion of hood to open and for ventilation purposes.



INSTALLATION INSTRUCTIONS (CONT.)

CONNECTING TO GAS SOURCE

Refer to the following instructions and illustrations for typical gas supply connections. We strongly suggest professional installation and hook-up of the gas griddle.

IMPORTANT: Before connecting griddle to gas source, make sure griddle control knobs are in "OFF" position.

NATURAL GAS CONNECTIONS

IMPORTANT: Bull Outdoor Products does not recommend the use of any quick connect fittings or lines to the unit. Use of these types of fittings or lines could cause low gas flow and greatly reduce the performance of the unit.

- Pipe sealing compound or pipe thread tape of the type resistant to the action of natural gas must be used on all male pipe thread.
- Apply compound or tape to at least the first three threads when making the connection.
- Remove plastic cap from regulator installed on griddle.
- Attach stainless steel flex line 3/8" flare-female end to the regulator.
- Attached the other end of flex line to shut-off valve through a nipple.
- Attach a shut-off valve to gas supply pipe.

PERFORM GAS LEAK CHECK – REFER TO PAGE 2

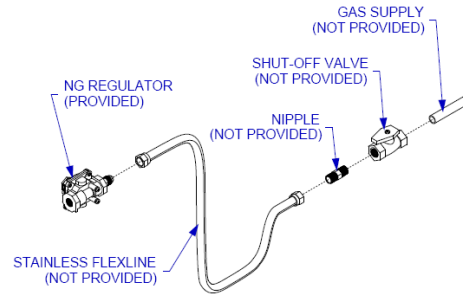

PROPANE GAS CONNECTIONS

- In the United States, the LP gas pressure regulator and hose assembly supplied with this unit must be used without alteration. If this assembly needs to be replaced, use only the type 1 specified in the parts list supplied with this unit. Use a LP tank with a type 1 cylinder valve.

- Make sure the tank is firmly secured in an upright position.
- Turn the black coupling nut of the hose and regulator assembly in a clockwise direction.
- Make sure it is completely threaded onto the cylinder valve before turning gas supply on.

PERFORM GAS LEAK CHECK – REFER TO PAGE 2

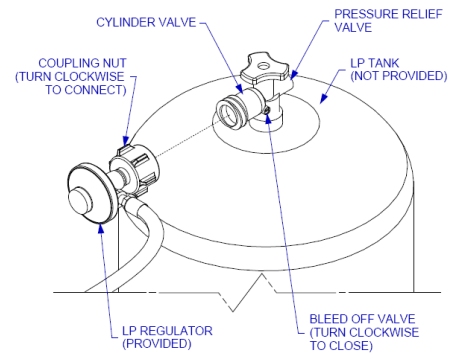

INSTALLATION INSTRUCTIONS (CONT.)

OUTDOOR NATURAL GAS GRIDDLE INSTALLATION SPECIFICATIONS



NOTE:

- Vents must be provided for combustion air and ventilation on both sides of built-in cabinet.
- When choosing a location for your gas griddle keep in mind that it should never be located under any overhead combustible construction.
- The sides and back of the griddle should not be any closer than **21 inches** to combustible construction.
- **DO NOT** store empty or full spare tanks under or near this or any other appliance.
- There must be a minimum of 6" counter space behind the griddle in order to allow the griddle hood to clear properly.

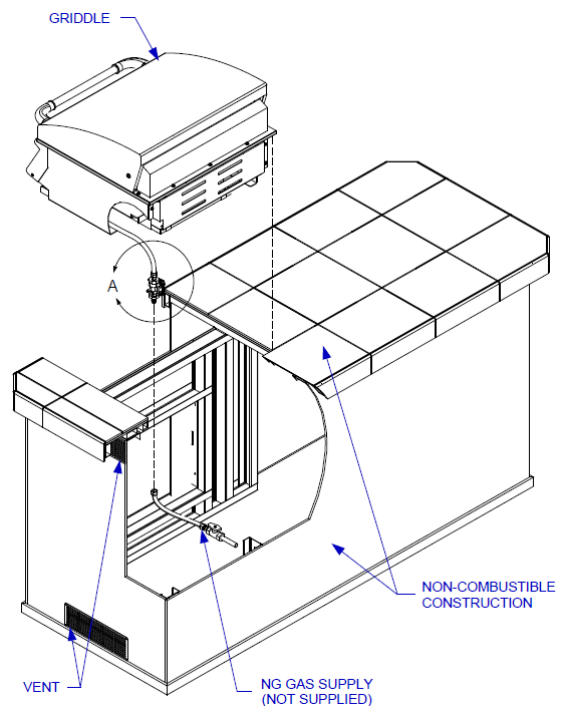
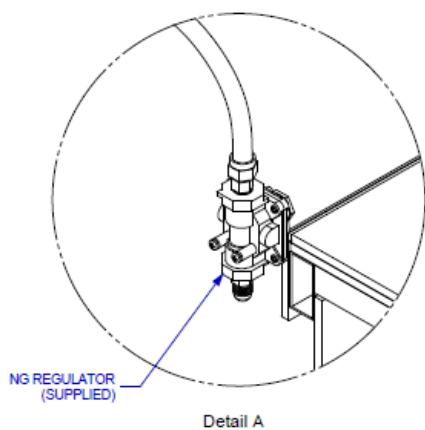
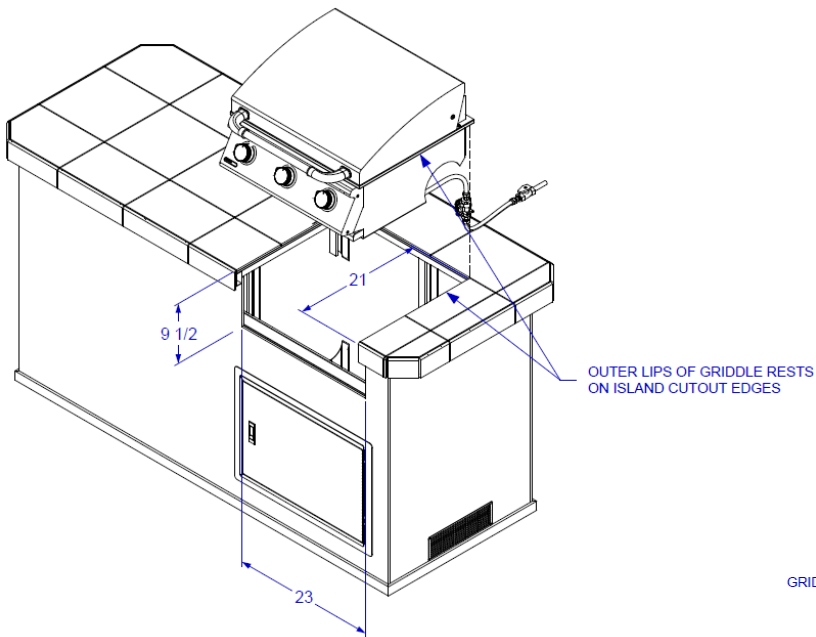

INSTALLATION INSTRUCTIONS (CONT.)

OUTDOOR PROPANE GAS GRIDDLE INSTALLATION SPECIFICATIONS

NOTE:

- Vents must be provided for combustion air and ventilation on both sides of built-in cabinet.
- When choosing a location for your gas griddle keep in mind that it should never be located under any overhead combustible construction.
- The sides and back of the griddle should not be any closer than **21 inches** to combustible construction.
- **DO NOT** store empty or full spare tanks under or near this or any other appliance.
- There must be a minimum of 6" counter space behind the griddle in order to allow the griddle hood to clear properly.
- The cylinder valve on the tank must be readily accessible for hand operation. The tank must be isolated enough to where it is shielded from radiation, open flames and protected from foreign matter such as hot drippings.
- There must be access so the tank can be connected, disconnected, inspected and leak tested outside of the cabinet. As well as access so that connections which could be disturbed when installing the tank in the cabinet can be leak tested inside the cabinet.

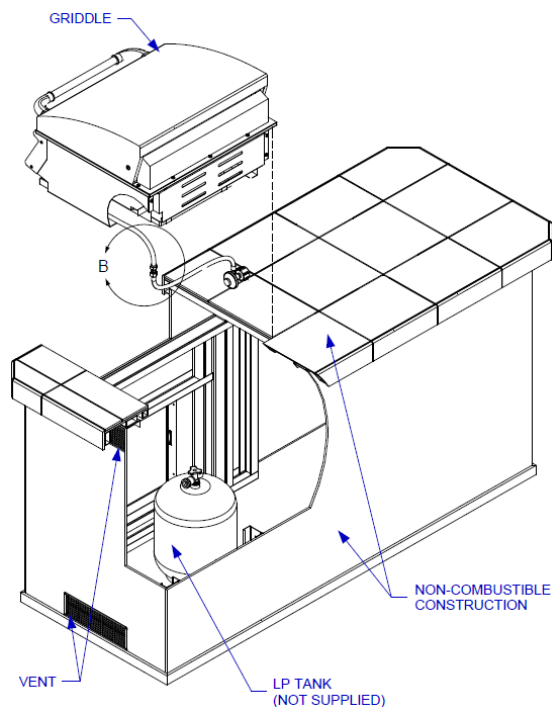
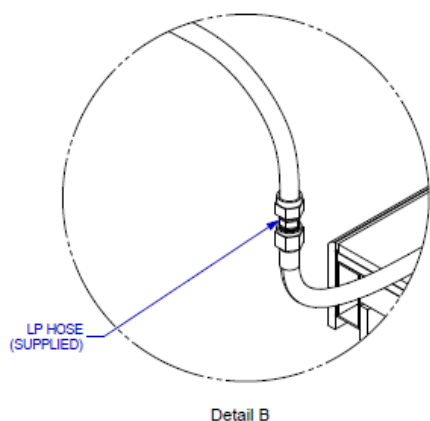
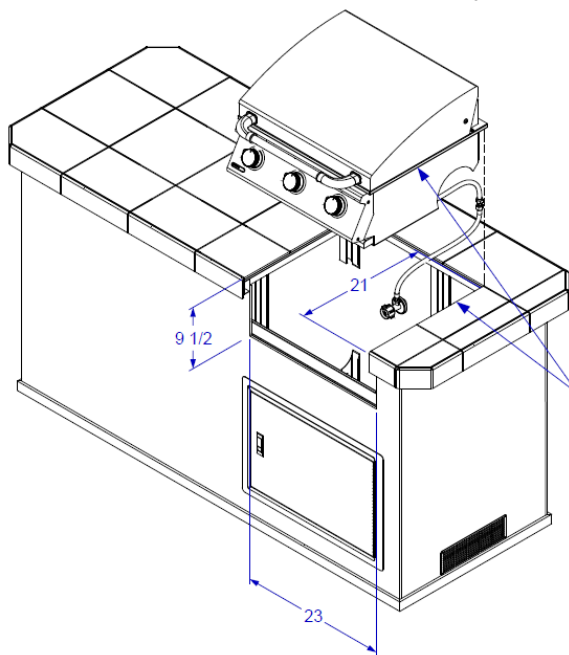

INSTALLATION INSTRUCTIONS (CONT.)

LP GAS TANK RETENTION



If using a LP gas tank, the tank must be properly secured within the structure to prevent being knocked over.

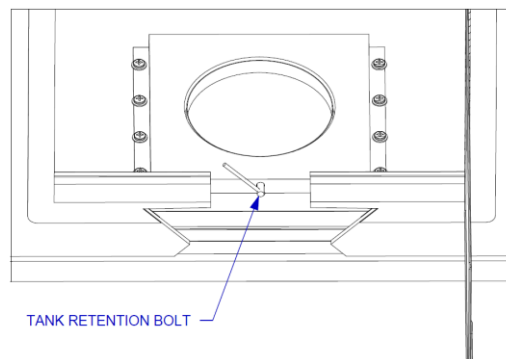
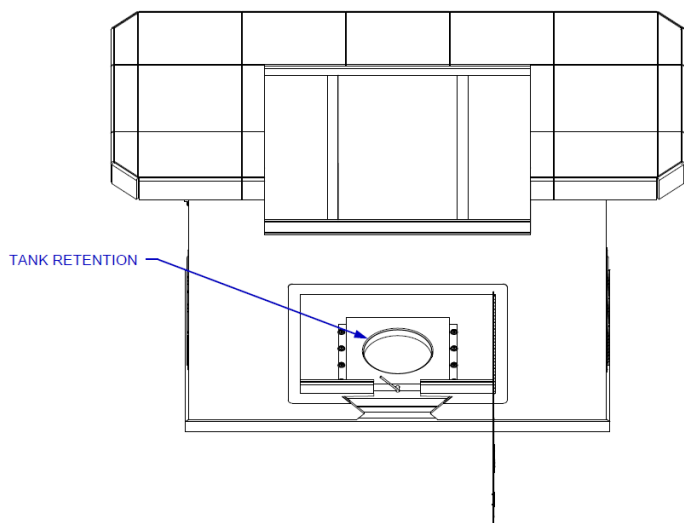

The tank retention system must be securely fastened to the bottom of the island with the use of bolts, washers and nuts. There must be a minimum clearance of 2" between the floor and the cylinder enclosure. Once secured, place the LP tank in the tank retention system and tighten the tank retention bolt until the tank is snug and cannot move.

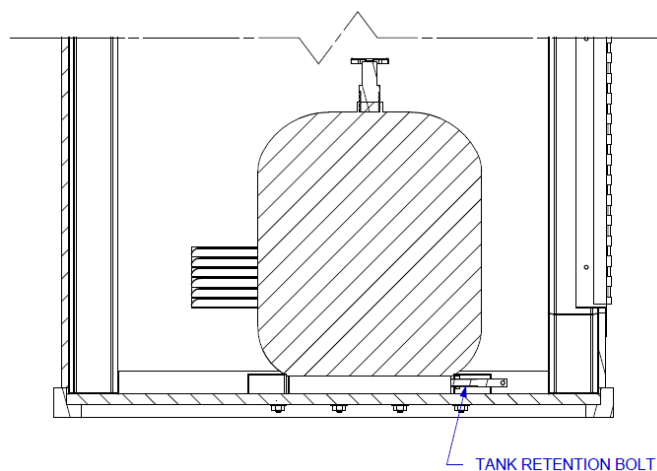
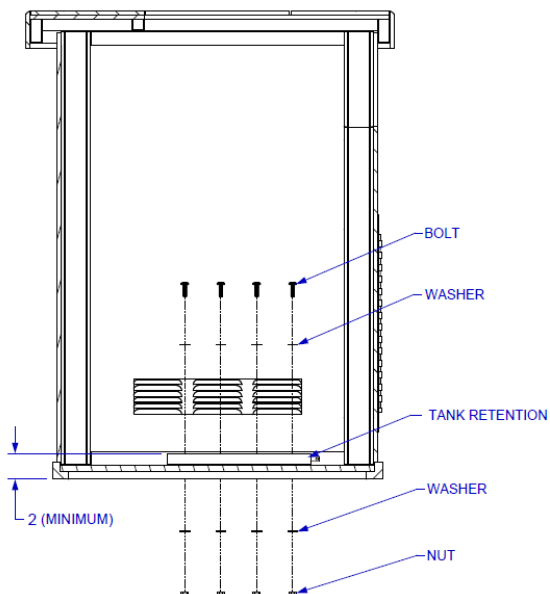

INSPECTING / CLEANING BURNERS AND GAS VALVE ORIFICES



By following these cleaning procedures on a timely basis, your griddle will be kept clean and working properly with minimum effort.

CAUTION – Always turn off the gas supply prior to clearing your griddle.

BURNER CLEANING

1. Remove burners from the insert assembly. Bend a stiff wire (a light-weight coat hanger works well) into a small hook as shown below. Run the hook through each burner tube and burner several times. Follow the instructions below to remove the burners.
2. Remove the lid screws.

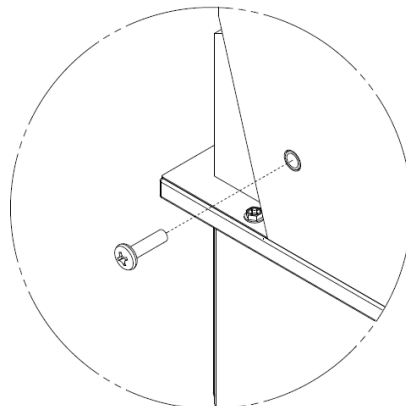
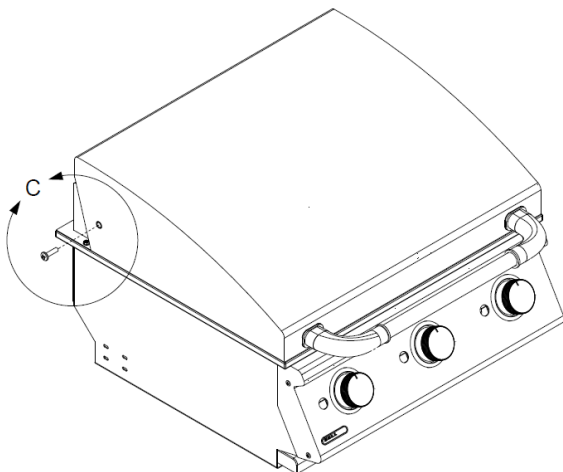

Detail C

3. Remove the two screws that attach the griddle insert to the rear lid.

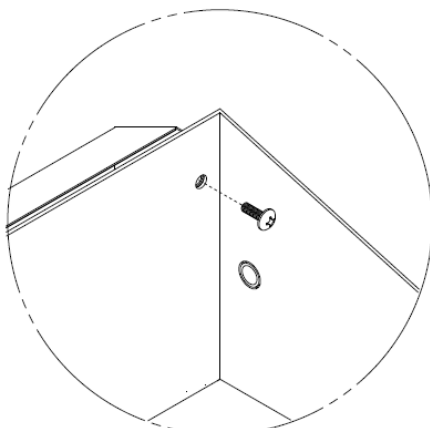
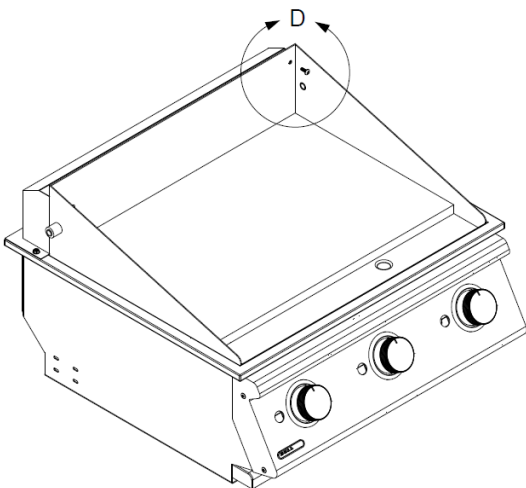

Detail D



INSPECTING / CLEANING BURNERS AND GAS VALVE ORIFICES (CONT.)

4. Remove the rear lid screws.

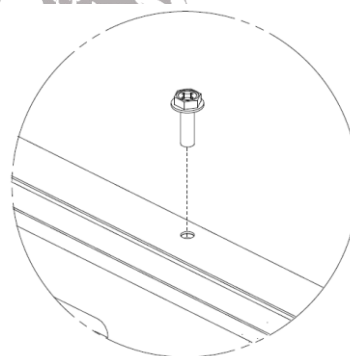
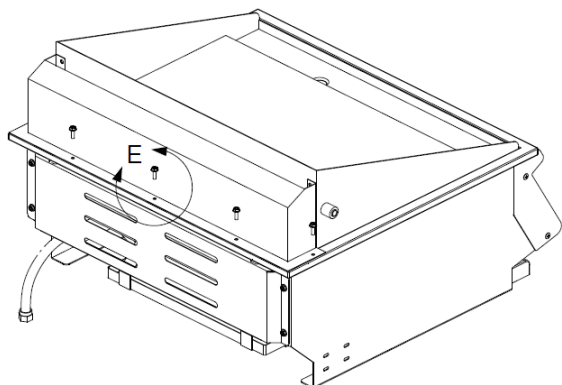

Detail E

5. Remove the bottom griddle insert screws.

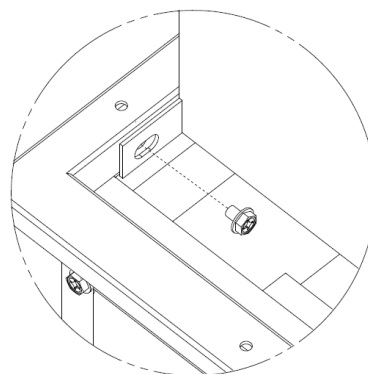
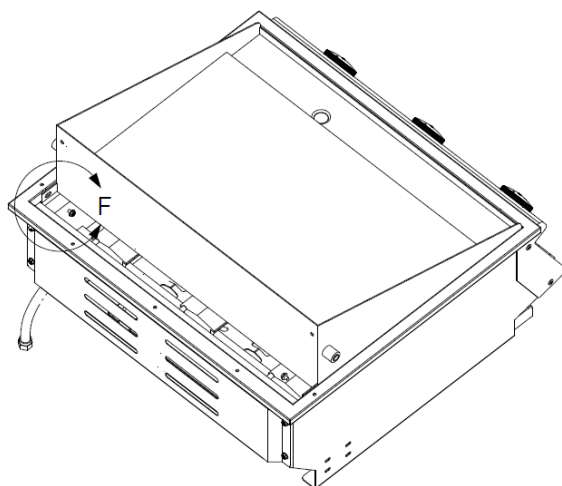

Detail F

6. Carefully remove the griddle insert to expose the burners.

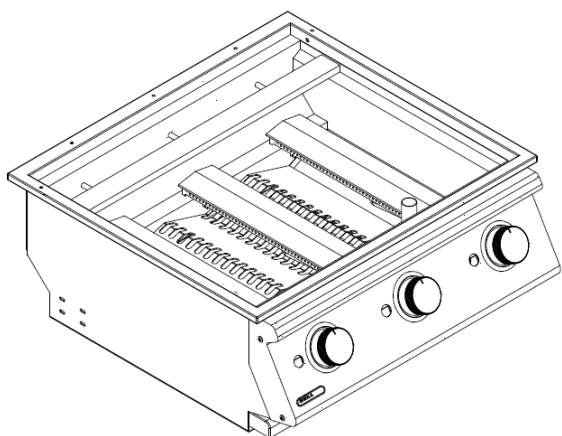

INSPECTING / CLEANING BURNERS AND GAS VALVE ORIFICES (CONT.)

7. Remove the cotter pin from each burner before attempting to lift up the burners.

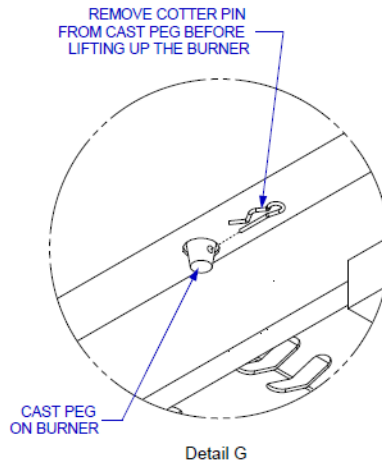
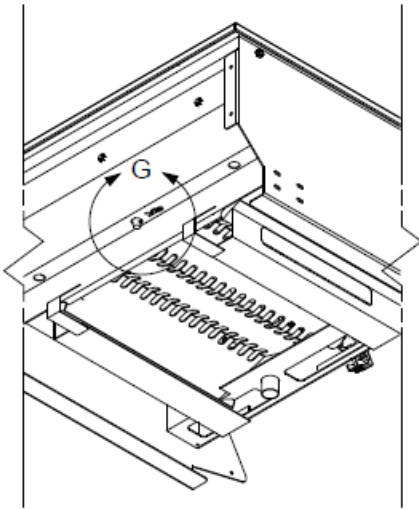

8. Use a narrow bottlebrush with a flexible handle. Run the hook through each burner tube and burner several times.
9. Wire brush entire outside surface of burner to remove loose corrosion.
10. Clean any clogged hole with a stiff wire (such as an open paper clip).
11. Inspect the burner assembly for any openings caused by corrosion.

BURNER SHUTTER CLIP INSPECTION / ADJUSTMENT

The burners are set to a factory setting; however the air to fuel mixture may need to be adjusted to accommodate different gas pressures. In order to adjust the air to fuel mixture, loosen the screw and rotate the shutter clip to the appropriate setting (see diagrams below). Tighten the screw and repeat adjustment procedure to the remaining burners. This should improve burner efficiency.

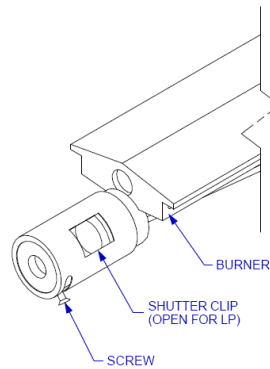
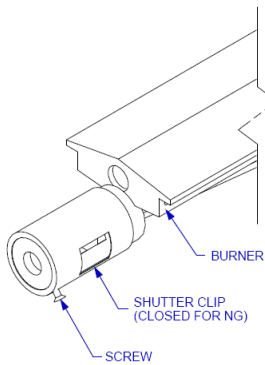

INSPECTING / CLEANING BURNERS AND GAS VALVE ORIFICES (CONT.)

BURNER REPLACEMENT INTO INSERT



CAUTION – Always turn off the gas supply prior to clearing your griddle.

1. Replace burners back into the insert assembly. There is no need to replace the cotter pin back into the cast peg, it is for shipping purposes only.
2. Check the burners for proper location after replacing. **Make sure the valve orifices are inside of the burner tubes (see drawing below). If the valve orifices do not fit inside the burner tubes, lighting the burners may cause explosion and/or fire.**

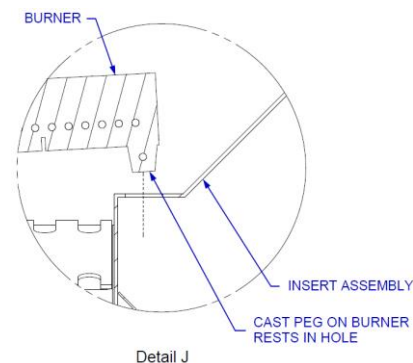
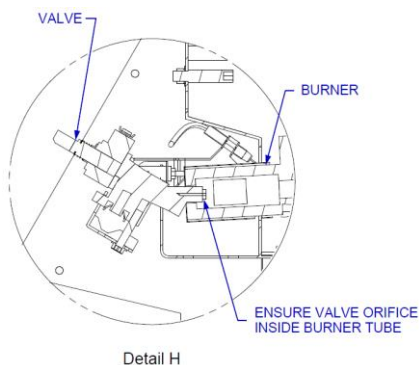
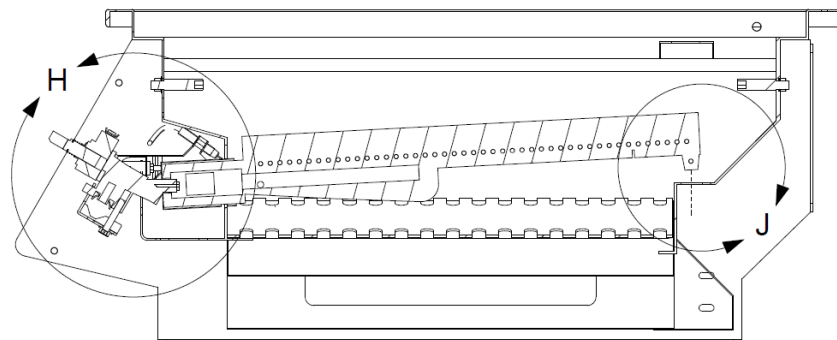

IGNITOR / ELECTRODE CHECK

With all control knobs set to "OFF", check each igniter individually for presence of spark at electrode. In turn, push each control knob in fully and turn slowly about a 1/4 turn to the left (counter-clockwise) until a click is heard; the trigger hitting the strike block should produce a blue spark at the electrode tip. Return control knob to "OFF" before checking next igniter.

BURNER OPERATION CHECK

NOTE: Upon first assembly the gas lines and burners will be full of air. In order for the burners to light properly the lines must fill with gas. It may require several attempts at lighting the burners before you are successful.

1. With griddle control knobs in "OFF" position, turn on the Gas supply.



INSPECTING / CLEANING BURNERS AND GAS VALVE ORIFICES (CONT.)

2. Light any burner by pushing its control knob in fully and slowly (3 to 4 seconds) turning it about 1/4 turn to the left (counter-clockwise) until a click is heard. The 3 to 4 second duration should provide enough gas to light the burner. If the burner does not light, immediately return the control knob to "OFF", wait several minutes for the gas to disperse, and repeat the process. After burner lights successfully, turn control knob to "OFF".
3. Repeat process for each control knob/igniter, in turn, ensuring that other knobs are in "OFF" position as you perform each check.
4. If any burners fail to light after several attempts, discontinue gas supply at source and re-inspect for obstructions to gas flow and orifices.

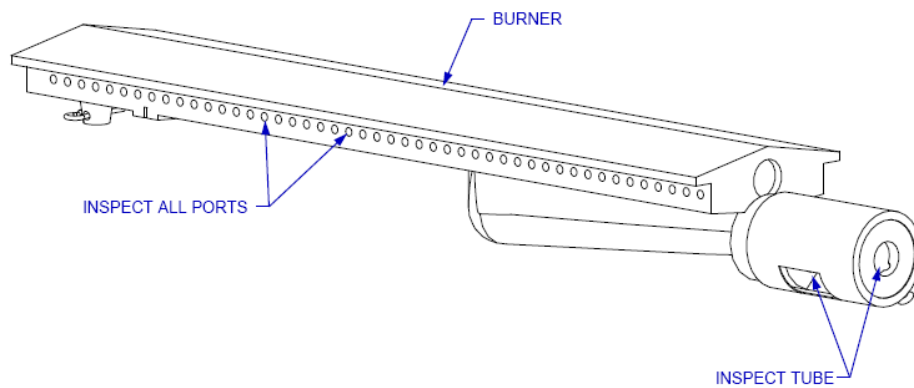
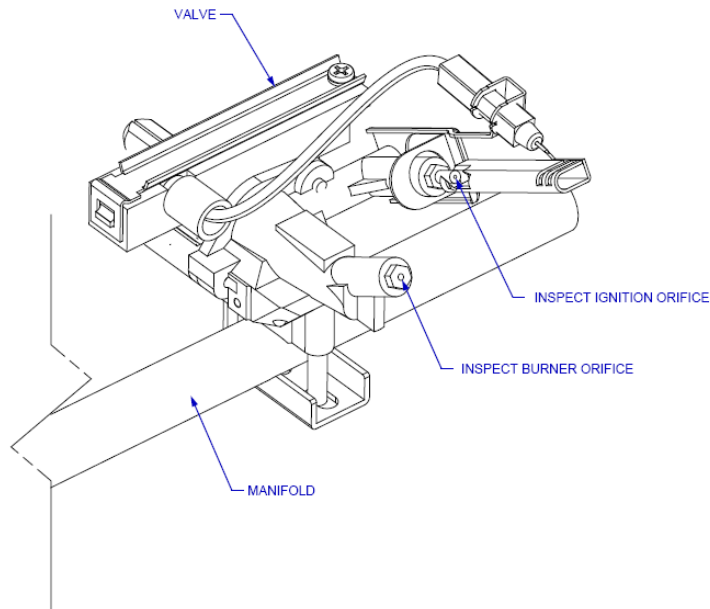

INSPECTING / CLEANING BURNERS AND GAS VALVE ORIFICES (CONT.)

FLEX LINE AND REGULATOR PLACEMENT

Due to packaging purpose, the regulator will be assembled horizontally in the carton. It is imperative that the regulator carefully be turned pointing downward before use.

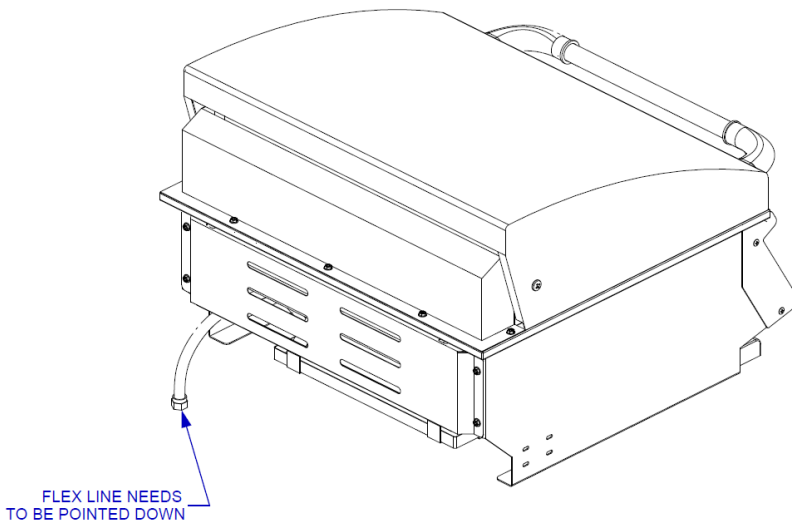
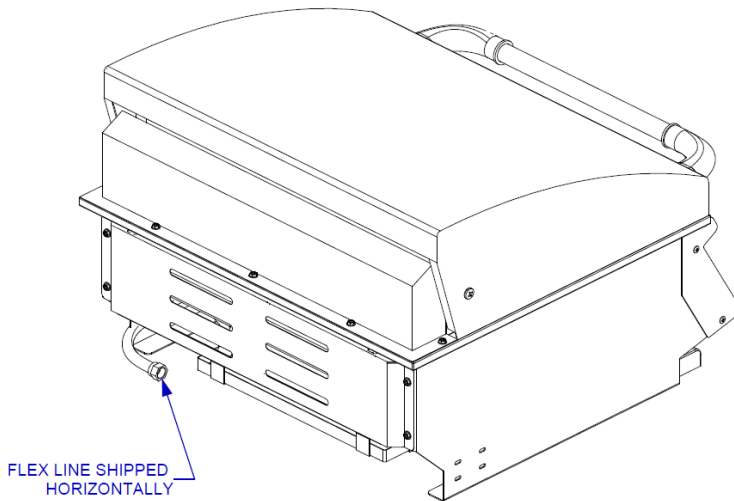

NOW YOUR GAS GRIDDLE IS READY TO USE!

Before first use and at the beginning of each season:

1. Please read Safety, Lighting and Operating Instructions carefully.
2. Check gas valve orifices, burner tubes and burner ports for any obstructions.
3. PERFORM GAS LEAK CHECK – REFER TO **PAGE 2**.



LIGHTING & OPERATING INSTRUCTIONS

LIGHTING PROCEDURES

Lighting Burner(s):

1. Become familiar with the safety guidelines at the front of the manual. **DO NOT SMOKE WHILE LIGHTING GRIDDLE OR CHECKING GAS SUPPLY CONNECTIONS!**
2. If your griddle fuel source is a LP gas cylinder, check to see that cylinder is filled.
3. Check that the end of each burner tube is properly located over each valve orifice.
4. Make sure all gas connections are securely tightened. **TEST FOR LEAKS WITH A SOAP SOLUTION, NEVER WITH A FLAME.** (Gas Leak Check instructions are on page 2).
5. Always open lid before lighting.
6. Set ALL griddle control knobs to "OFF" and open gas supply, LP cylinder or Natural Gas Valve.
7. Ignite only the burners you intend to use, using the same method for each: Push in control knob completely and rotate slowly (3 to 4 seconds) about 1/4 turn to the left (counter clockwise) until a click is heard. The 3 to 4 second duration should provide enough gas to light the burner. If the burner does not light, immediately return the control knob to 'OFF', wait several minutes for the gas to disperse, and repeat the process. After burner ignites, repeat procedure with any other burner needed.
8. Adjust control knob(s) to desired cooking temperature.

OPERATING PROCEDURE

WARNING! GRIDDLE HOOD NEEDS TO STAY OPEN WHILE IN USE

Burn-off: Before cooking on your gas griddle for the first time, burn the griddle to get rid of any odors or foreign matter by igniting the burners, closing the lid, and operating at "HIGH" setting for about five minutes. You may then either set the controls to "OFF" or cook on your griddle immediately by turning the control knobs to a lower setting.

CAUTION: DO NOT LEAVE GRIDDLE UNATTENDED WHILE IN USE.

Preheating: It is necessary to preheat the griddle for a short time before cooking certain foods, depending on the type of food and the cooking temperature. Food that requires a high cooking temperature needs to preheat for five minutes; food that requires a lower cooking temperature needs only a period of two to three minutes. There is no need to preheat for foods that require slow cooking.

CAUTION: If burners go out during operation, close gas supply at source, and turn all gas valves off. Open lid and wait five minutes before attempting to re-light (this allows accumulated gas fumes to clear).

CAUTION: Should a grease fire occur, close gas supply at source, turn off all burners and leave lid closed until fire is out. Do not use water or any liquid to extinguish a grease fire.

CAUTION: Do not attempt to disconnect any gas fitting while your griddle is in operation or while gas feed is on.



CLEANING & MAINTENANCE

CLEANING THE GRIDDLE INSERT

If grease is allowed to accumulate on the griddle surface, it will carbonize and become difficult to remove. In order to avoid this, regular maintenance and cleaning is required. To clean griddle surface, follow these steps:

1. Remove excess oil, grease and food with a thin scraper.
2. Use a damp, non-abrasive cloth with a non-chlorinated cleaner.
3. Wipe surface with the clean damp cloth.

DO NOT use steel wool, abrasives or griddle stones on the griddle surface.

DO NOT use any type of grill cleaner on the griddle surface.

DO NOT hit the griddle surface with any sharp object or utensil.

CLEANING THE BURNERS

IMPORTANT: Gas control knobs should be in the "OFF" position, and fuel line should be disconnected from gas valve manifold. To reduce the chance of FLASHBACK, the procedure below should be followed at least once a month or when your griddle has not been used for an extended period of time.

1. Remove burners from griddle by carefully lifting each burner up and away from gas valve orifice.
2. Wire brush entire outer surface of burner to remove residue and dirt. Clean any clogged ports with a stiff wire such as an open paper clip.
3. Inspect the burner for damage (cracks or holes) and if such damage is found, order and install a new burner.
4. After installation, check to insure that gas valve orifices are correctly placed inside ends of burner tubes. Also check position of spark electrode.

CLEANING THE GREASE TRAY

The grease tray should be emptied and wiped down periodically and washed in a mild detergent and warm water solution.

ANNUAL CLEANING OF GRIDDLE HOUSING

Cleaning the griddle after every cookout will keep it ready for instant use. However, periodically the griddle should be given an entire thorough cleaning to ensure optimal performance.

1. Shut off gas supply at source and disconnect fuel line from gas valve manifold. Protect fuel line fitting.
2. Remove and clean (as explained above) the griddle insert, burners and grease tray.
3. Cover the gas valve orifices with a piece of aluminum foil.
4. Brush the inside and bottom of the insert assembly with a stiff wire brush, and wash down with a mild soap and warm water solution. Rinse thoroughly and let dry.
5. Remove aluminum foil from orifices and check orifices for obstruction.
6. Check electrode as instructed on page 13.
7. Replace grease tray, burners and griddle insert.
8. Reconnect to gas source and observe burner flame for correct operation.

IMPORTANT: You should NOT line the bottom of the griddle housing with aluminum foil, sand or any other grease absorbent substance. Grease will not be able to drip down into the grease tray and a grease fire could occur.

STAINLESS STEEL CLEANING AND MAINTENANCE

Stainless steel is a corrosion resistant chromium/nickel alloy steel that is both durable as well as strong with an outstanding luster. The goal of your cleaning and maintenance routine should be to keep the stainless steel's protective chromium oxide layer intact. This is what prevents corrosion. Contrary to popular belief, stainless steel is NOT rustproof, especially in the environment of a swimming pool. Chlorine, bromine, some fertilizers and other elements are extremely caustic chemicals for stainless steel. These chemicals combined with heat and humidity greatly increase the corrosiveness of these chemicals. Regular cleaning is the best way to prevent corrosion and add years of enjoyment to your Bull stainless steel products.



TROUBLESHOOTING

IF GRIDDLE FAILS TO OPERATE PROPERLY

BULL



1. Turn off gas at source, turn control knobs to "OFF", and wait five minutes before trying again.
2. Check gas supply/connections.
3. Repeat lighting procedure.

If griddle still fails to operate properly, **TURN "OFF" GAS AT SOURCE, TURN CONTROL KNOBS TO "OFF"**, wait for griddle to cool, and check the following:

a. Misalignment of burner tube(s) over orifice(s)

CORRECTION: Reposition burner tube to properly seat over orifice.

b. Obstruction in gas line

CORRECTION: Remove fuel line from griddle. **DO NOT SMOKE!** Open gas supply for one second to blow any obstruction from fuel line. Close off gas supply at source and reconnect fuel line to griddle.

c. Plugged orifice

CORRECTION: Remove griddle insert, burners and grease tray. Remove burners from bottom of griddle housing by pulling cotter pin from beneath burner peg using a screwdriver or needle nose pliers (Please reference the diagram on page 12). Carefully lift each burner up and away from gas valve orifice. Remove the orifice from each burner up and away from gas valve and gently clear any obstruction with a fine wire. Re-install each orifice, reinstall burners over orifices and seat each burner peg into mounting bracket at bottom of insert assembly. There is no need to replace the cotter pins, they are for shipping purposes only. Replace the griddle insert and grease tray. If an obstruction is suspected in gas valve(s) or gas valve bracket, please contact your gas griddle dealer or gas appliance service person for assistance.

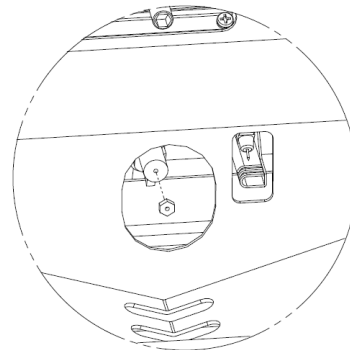
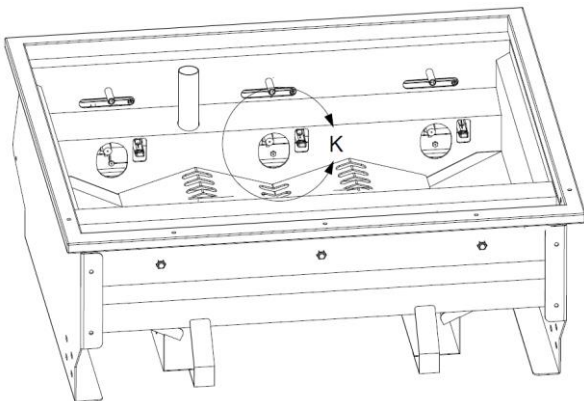

Detail K

d. Misalignment of igniter on burner

CORRECTION: Check for proper position of electrode tip. The tip of the electrode should be pointing forward toward the front and free from grease for spark discharging. The ignition wire should be firmly connected to the valve ignition and electrode. Replace the ignition wire if the wire were broken or cracked. With gas supply closed and all control knobs set to "OFF", check each positive igniter individually for presence of spark at electrode. In turn, push each control knob in fully and rotate about 1/4 turn to the left (counter-clockwise) until click is heard; the trigger hitting the strike block should produce a blue spark at the electrode tip. Return control knob to "OFF" before checking next igniter.

If re-ignition is necessary

While the gas griddle is still hot, you must wait for a minimum of five minutes before commencing to re-ignite (this allows accumulated gas fumes to clear). If all checks/corrections have been made and gas griddle still fails to operate properly, consult your griddle dealer or gas appliance service person.



TROUBLESHOOTING (CONT.)

YELLOW FLAME

Once the entire burner is operating, check the flame color to be sure it is mostly blue (some yellow color will be present because of impurities in the fuel). If the flame is golden or yellow in color the reason could be oil film or other foreign matter on burner.

CORRECTION: Either wash burner with mild detergent, or operate burner at "HIGH" setting with lid closed for about 10 minutes.

FLASH BACK

When fire occurs in and around the burner tubes, immediately turn off gas at its source and turn the control knob(s) to "OFF". Wait until the griddle has cooled, then clean the burner tubes and burner ports as described on page 12.



LOCATIONS OF SERIAL NUMBER

Essential information about your product is encoded in the serial number of your griddle. This information will be required for all warranty claims, ordering replacement parts and will identify any variations of your unit. It is extremely important that you record your serial number and register your grill from the Proof of Purchase. The serial number of your griddle is located in the following areas:

1. At the end of the box

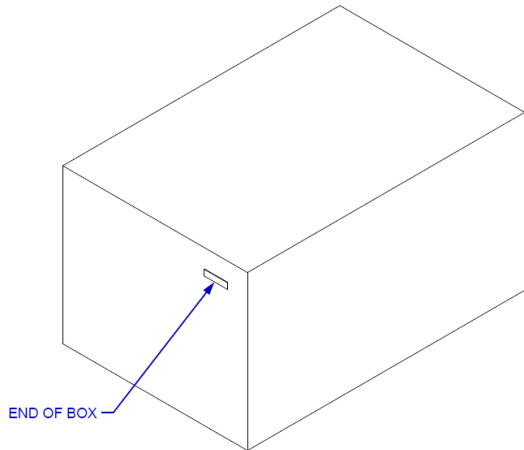

2. Interior flap of the box

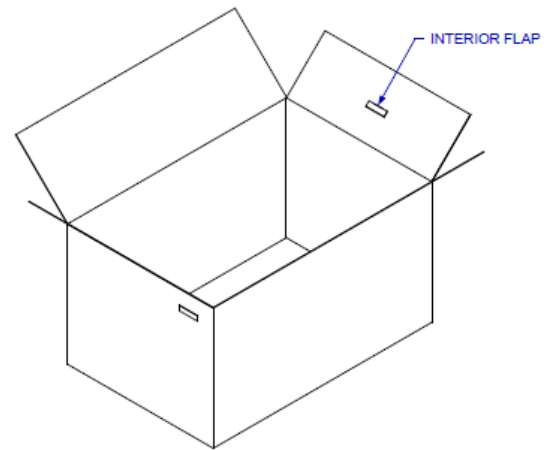

3. Reverse side of the grease tray

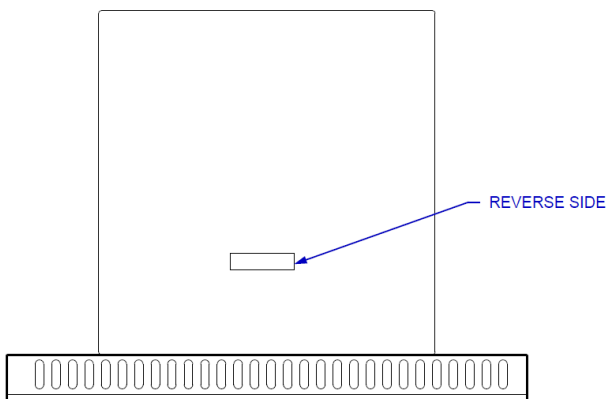

4. Left interior panel of the insert assembly

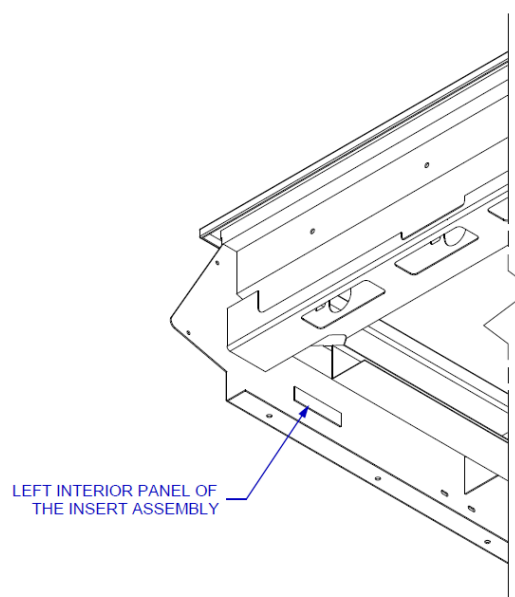

PARTS LIST

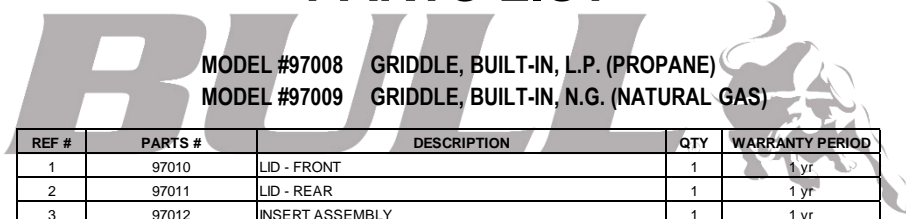

MODEL #97008 GRIDDLE, BUILT-IN, L.P. (PROPANE)
 MODEL #97009 GRIDDLE, BUILT-IN, N.G. (NATURAL GAS)

REF #	PARTS #	DESCRIPTION	QTY	WARRANTY PERIOD
1	97010	LID - FRONT	1	1 yr
2	97011	LID - REAR	1	1 yr
3	97012	INSERT ASSEMBLY	1	1 yr
4	97013	GRIDDLE INSERT	1	1 yr
5	97014	CONTROL PANEL	1	1 yr
6	97015	BACK PANEL	1	1 yr
7	44305	STAINLESS STEEL BURNER	3	5 yrs
8	97016	LID HANDLE	1	3 yrs
9	16522	LID HANDLE END CAP	2	3 yrs
10	16629	BEZEL	3	1 yr
11	16613	KNOB	3	1 yr
12	16525(LP) / 16524(NG)	GAS VALVE	3	1 yr
13	16507	REGULATOR - NATURAL GAS MODEL ONLY	1	1 yr
14	16508	REGULATOR - LIQUID PROPANE MODEL ONLY	1	1 yr
15	16599	REGULATOR ADAPTER - NATURAL GAS MODEL ONLY	2	1 yr
16	16598	REGULATOR ADAPTER - LIQUID PROPANE MODEL ONLY	1	1 yr
17	97018	MANIFOLD	1	3 yrs
18	47020	STAINLESS FLEX TUBE 24"	1	1 yr
19	97019	GREASE TRAY	1	1 yr

HOW TO ORDER REPLACEMENT PARTS

Please refer to the parts list on this page.

To make sure you obtain the correct replacement parts for your gas griddle, the following information is required to assure getting the correct part.

1. Gas griddle model number (see data sticker on griddle) and type of gas hook up.
2. Reference number of replacement part needed.
3. Description of replacement part needed.
4. Quantity of parts needed.

IMPORTANT: Use only factory authorized parts. The use of any part that is not factory authorized can be dangerous. This will also void your warranty.

IMPORTANT: Keep this assembly and operating instruction manual for referral, and for replacement parts ordering.

CAUTION: Gas valves are preset at the factory. If you wish to convert at some later date, be sure to contact your gas supplier or griddle dealer before making the conversion.

CAUTION: A different gas valve must be installed when converting from one type of gas to another. You will also need a data plate indicating what type of gas the grill uses.



EXPLODED ILLUSTRATION

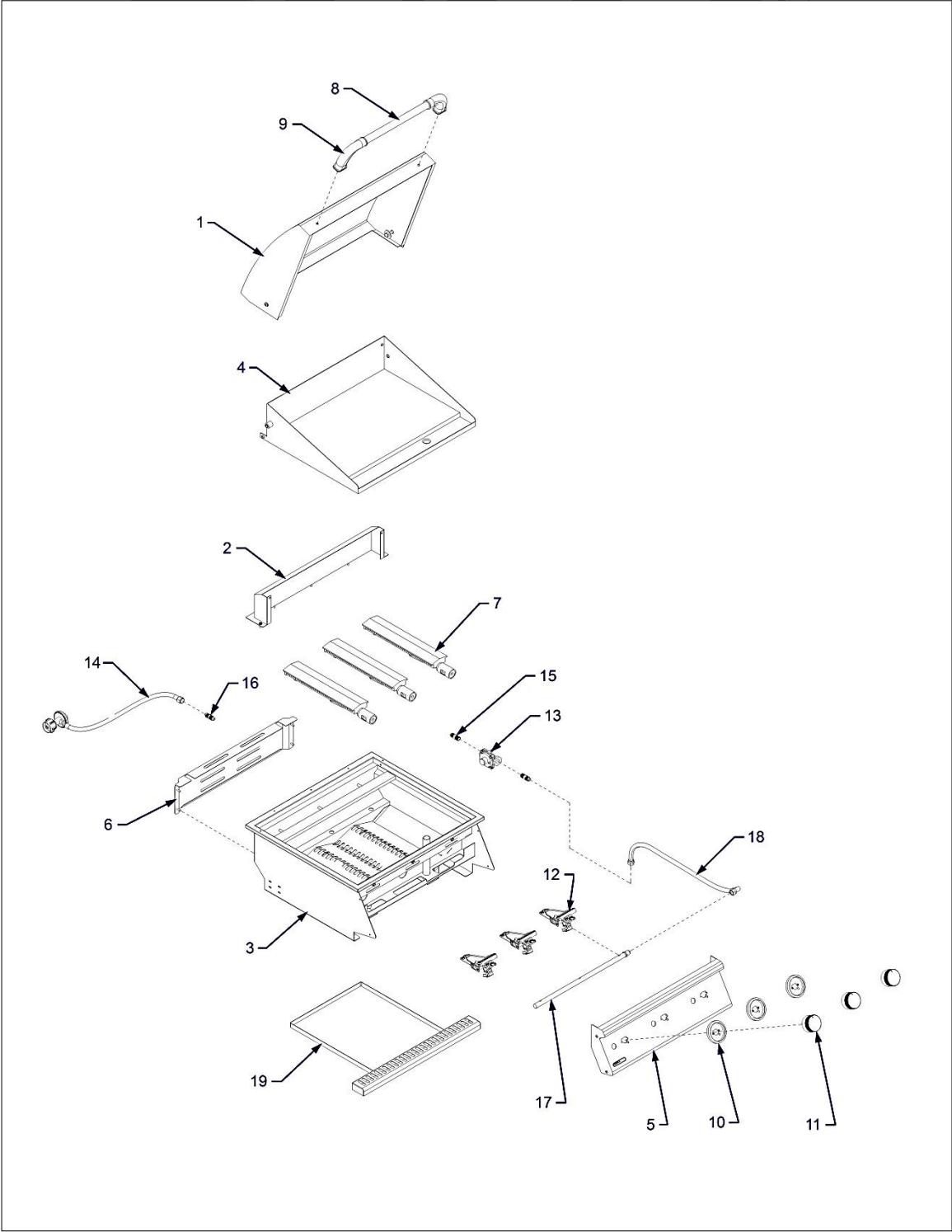

LIMITED WARRANTY

REGISTERING YOUR GRIDDLE



In order to validate your Bull Limited Warranty, you must complete the Warranty Registration Card within 90 days from the Proof of Purchase. You may register your unit either online at www.bullbbq.com or by sending in the completed hard copy along with a copy of the Proof of Purchase to:

Product Registration
Bull Outdoor Products
2483 W Walnut Ave
Rialto, CA 92376

Bull Outdoor Products, Inc. warrants to the original purchaser at the original site of delivery with proof of purchase of each Outdoor Gas Griddle that when subject to normal residential use, it is free from defects in workmanship and materials for the periods specified below. This warranty excludes griddles used in rental or commercial applications. It does not apply to rust, corrosion, oxidation or discoloration, which may occur due to moisture or overheating, unless the affected component becomes inoperable. It does not cover labor or labor related charges. There will be a shipping and handling charge for the delivery of the warranty part(s).

Our obligation under this warranty is limited to repair or replacement, at our option, of the product during the warranty period. The extent of any liability of Bull Outdoor Products, Inc., under this warranty is limited to repair or replacement. This warranty does not cover normal wear of parts, damage resulting from any of the following: negligent use or misuse of the product, use on improper fuel/gas supply, use contrary to operating instructions, or alteration by any person other than our factory service center. The warranty period is not extended by such repair or replacement.

Warranty claim procedure: If you require service or parts for your Bull griddle or if you have any questions about warranty, please contact our Warranty Service Center for factory direct assistance. Our hours of operation are 5AM to 5PM PST. Our phone number is **(800) 521-2855** and our FAX number is **(909) 770-8627**.

Product repair as provided under this warranty is your exclusive remedy. Bull Outdoor Products, Inc. shall not be liable for any incidental or consequential damages for breach of any express or implied warranty on its products. Except to the extent prohibited by applicable law, any implied warranty or merchantability or fitness for a particular purpose on this product to the duration of the above warranty. Some states do not allow the exclusion or limitation of incidental or consequential damages, or allow limitations on how long an implied warranty lasts, so the above limitations or exclusions may not apply to you. This warranty gives you specific legal rights, and you may have other rights, which vary from state to state.

Model Number _____

Serial Number _____

Date of Purchase _____

Attach a copy of your receipt or invoice here

