

MAKE THE MOST OF YOUR



CARE & USE/INSTALLATION
LPZA and LPZAF Napoli Pizza Ovens

WARNINGS



WARNING

READ THIS MANUAL CAREFULLY and completely before using your oven to reduce the risk of:

1. Fire
2. Burn hazard, personal injury or property damage
3. Ruined pizza or other unpleasant cooking experiences
4. Unapproved installation or servicing.

THIS PRODUCT IS DESIGNED FOR OUTDOOR USE ONLY. Improper installation, adjustment, alteration, service or maintenance can cause property damage, injury or death.

Read this manual thoroughly before installation, use, or servicing of this product.



DANGER

IF YOU SMELL GAS:

1. Shut off all gas supply lines to the oven.
2. Extinguish any open flames.
3. Carefully open the oven door. Remember, it may be extremely hot!
4. If odor continues, keep everyone away from the oven and immediately call your gas supplier or your fire department.



DANGER

S'IL Y A UNE ODEUR DE GAZ:

1. Coupez l'admission de gaz de l'appareil.
2. Éteindre toute flamme nue.
3. Ouvrez soigneusement la porte du four .
Rappelez-vous , il peut être extrêmement chaud!
4. Si l'odeur persiste, éloignez-vous de l'appareil et appelez immédiatement le fournisseur de gaz ou le service d'incendie.



WARNING

1. DO NOT store or use gasoline or other flammable vapors and liquids in the vicinity of this or any other appliance.
2. An LP cylinder not connected for use shall not be stored in the vicinity of this or any other appliance.



AVERTISSEMENT

1. Ne pas entreposer ni utiliser de l'essence ni d'autres vapeurs ou liquides inflammables dans le voisinage de l'appareil, ni de tout autre appareil.
2. Une bouteille de propane qui n'est pas raccordée en vue de son utilisation, ne doit pas être entreposée dans le voisinage de cet appareil ou de tout autre appareil.



WARNING! CALIFORNIA PROPOSITION 65

1. The burning of gas cooking fuel generates some by-products which are on the list of substances which are known by the State of California to cause cancer or reproductive harm.
2. California law requires businesses to warn customers of potential exposure to such substances. To minimize exposure to the substances, always operate this unit according to the use and care instructions found in this manual. Be certain to provide adequate ventilation when cooking.
3. California Proposition 65 lists "Silica, crystalline" which is used in one of the components of the IR burner, as an agent known to the state of California to cause cancer.



HOW TO LIGHT YOUR NAPOLI PIZZA OVEN

Note: The main burners feature safety control valves with thermocouple sensors that automatically shut off the flow of gas if the burner goes out for any reason.

1. Before each use, complete the checklist below.
2. Make sure all burner control knobs are in the "OFF" position.
3. Push and hold the control knob for 2 – 5 seconds.
4. Turn the knob to the "LITE" position and continue to hold the knob in for an additional 10 – 20 seconds to allow the thermocouple to heat up and keep the safety valve open.
5. If the burner should go out, turn the knob off for 1 minute and repeat steps 3 and 4.

CHECKLIST BEFORE EACH USE (FOR YOUR SAFETY)

- Do you smell gas? If yes, shut off everything and call the gas company or a qualified plumber to check for leaks, if not please continue.
- Are you prepared to stay with the oven during the entire cooking process? If not, gather what you need before starting the lighting process. If yes, please continue.
- Is your cooking area free and clear of any combustibles, besides your food, that might ignite? If no, clear the area before starting the lighting process, If yes, please continue.
- Do all control knobs turn freely? If not, call for service, if yes, please continue.
- If you are using a portable propane cylinder, is it connected and leak tested? If not, check the connection before continuing. If yes please continue.
- Do you know where your oven's main gas supply shut off valve is located? If not, locate it before continuing. If yes, please continue.
- Is the wind blowing just lightly and not blowing on the front of the oven? If not, you could wait until the wind subsides, or you can reposition the oven so that wind blows into the back. Another option is to reposition the vent exhaust opening to face forward or backward as needed.

WARNINGS



WARNING

- Never use dented, rusty or damaged propane cylinders. Never store additional or empty propane cylinders in the oven cabinet or in the vicinity of this or any other appliance. Do not store propane cylinders indoors or on their sides.
- Children should never be left alone or unattended in an area where an oven is located. Place your oven well away from areas where children play. Do not store items that may interest children in or around the oven, in the cart, or in the masonry enclosure.
- Never move the oven when hot. When in use, portions of the oven are hot enough to cause severe burns.
- Always maintain the required clearances from combustibles as detailed. The oven is designed for outdoor use only. Never use in a garage, building, shed, breezeway, or other enclosed area. Do not use this oven under any unprotected combustible construction.
- Gas ovens are not designed or certified for and are not to be installed in or on recreational vehicles, portable trailers, boats or any other moving installation.
- Always have an ABC Fire Extinguisher accessible — never attempt to extinguish a grease fire with water or other liquids.
- Storing your oven: Store your oven in a well-ventilated area. If stored indoors, detach and leave L.P. cylinder outdoors in a well-ventilated area away from heat and away from where children may tamper with it.
- Keep any electrical supply cord and the fuel supply hose away from any heated surfaces. Electrical cords should be placed away from walkways to avoid tripping hazard.
- Do not repair or replace any part of the oven unless specifically recommended in this manual. Other service should be performed by a qualified technician.
- If the oven is installed by a professional installer or technician, be sure that he/she shows you where your gas supply shut-off is located. All gas lines must have a shut-off that is readily and easily accessible. If you smell gas, check for gas leaks immediately. Check only with a soap and water solution. (See INDEX: “Leak Testing” for further details.) Never check for gas leaks with an open flame.
- Inspect the LP gas supply hose prior to each use of the oven. If there is evidence of excessive abrasion or wear, or the hose is cut, it must be replaced before using the oven.
- Never remove the grounding prong from the plug or use this product with an ungrounded, 2-prong adapter.

THIS MANUAL MUST REMAIN WITH THE PRODUCT OWNER FOR FUTURE REFERENCE.

This product complies with ANSI standard Z21.58/CSA 1.6 latest edition and has been tested and approved by Intertek.



To obtain replacement parts or service contact:

Lynx Grills, Inc.
7300 Flores Street
Downey, CA 90242
888-289-5969

A MESSAGE TO OUR CUSTOMERS

You've just joined the world of Lynx cooks ... a discriminating collection of amateur and professional chefs that take outdoor cooking to a new level.

Your oven has been designed and built with meticulous attention to detail and it offers some unique and powerful features. You can achieve maximum performance and enjoyment of these features only by carefully reading this manual ... before your first cook-out.

This manual includes important safety tips and great hints for better cooking. You'll want to keep it handy for easy reference.

Also, at Lynx, we enjoy hearing from our customers. We like to hear about your successes but also about any difficulties you are having. Please feel free to contact us with any questions or problems, or just to share a new recipe. Please include the model number of your oven in your correspondence.

With the proper use and care this product will provide years of trouble-free service.

Should your Lynx oven change ownership, please make sure that the new owner receives this manual.

Thanks again for your purchase. Enjoy!



TABLE OF CONTENTS

HOW TO LIGHT YOUR OVEN	3
CHECKLIST BEFORE EACH USE	3
A MESSAGE TO OUR CUSTOMERS	5
USE & CARE GUIDELINES	7
Lynx Oven Models	7
IMPORTANT SAFETY PRECAUTIONS	8
COOKING IN WINDY CONDITIONS	9
USING YOUR LYNX OVEN	10
Pre-Bake Checklist	10
Cooking Suggestions	11
Lighting your Oven	13
CLEANING YOUR LYNX PIZZA OVEN	14
TROUBLESHOOTING YOUR LYNX OVEN	15
Potential Problems	15
Contacting Lynx Customer Care	18
The Lynx Story	18
LYNX LIMITED WARRANTY	19
LYNX COMMON AREA LIMITED WARRANTY	20
BEFORE YOU START	22
If Shipment Arrives Damaged	22
Important Notes	22
UNPACKING & ASSEMBLY	23
SPECIFICATIONS & INSTALLATION	25
GAS CONNECTIONS	26
Natural Gas	26
LP Gas	27
ELECTRICAL CONNECTIONS	29
FINAL CHECKS	30
Leak Testing	30
WIRING SCHEMATICS	31
LYNX PROFESSIONAL EXPLODED PARTS VIEW	32
LYNX PROFESSIONAL PARTS LIST	33
MODEL-SPECIFIC BTU OUTPUTS & MAX. RUNS FOR APPLIANCES	34
INDEX	35

USE & CARE GUIDELINES

This use & care manual covers the Lynx Napoli Pizza Oven models listed below. Some features and options will vary based upon the model that you purchased.

LYNX OVEN MODELS

BUILT-IN	FREESTANDING
LPZA	LPZAF

COUNTER TOP MODELS
LPZA

The Napoli Pizza Oven comes equipped with legs ready for counter top installation. For built-in applications remove the legs and follow the cut out dimensions found in this manual.



IMPORTANT SAFETY PRECAUTIONS

PLEASE REVIEW THESE IMPORTANT SAFETY PRECAUTIONS BEFORE YOU USE YOUR OVEN.

1. NEVER LEAVE THE OVEN UNATTENDED WHILE COOKING.
2. Always use caution when operating the oven in a windy area. (See INDEX: "Baking in Windy Conditions" for further details.)
3. Avoid wearing loose-fitting garments or long sleeves while baking. They could ignite.
4. Never touch the hot surfaces or immediate surrounding metal surfaces with your bare hands while baking.
5. Use an insulated glove or mitt when opening and operating the oven.
6. Do not heat unopened food containers as pressure build-up will cause the container to explode.
7. Inspect the LP hose before each use. If the hose shows excessive wear or abrasion, or the hose is cut it must be replaced with a hose assembly available from Lynx Grills.
8. Never use charcoal or any other solid fuel in the oven.
9. Spiders and insects like to nest in the burners, venturis, valves and orifices of an oven, disrupting the gas flow. This very dangerous condition can cause a fire behind the control panel, damaging the oven and risking personal injury. If your oven has been unused for a long time, inspect and clean the venturis, valves and orifices.
10. Do not use the oven unless a leak check has been performed on all gas connections. (See INDEX: "Leak Test Procedure" for further details.)
11. Never operate the oven while under the influence of alcohol or drugs.
12. Do not lean on side shelves and never place a load weighing more than 25 pounds on a side shelf.
13. If any burner does not light or goes out during operation, turn off all gas control knobs, open the oven and wait five (5) minutes before attempting to re-light.
14. Portable LP cylinders: Always shut off the main valve on the LP cylinder after each use.



COLD WEATHER WARNING: PROPANE

Extremely cold temperatures may cause your burners to light *inside* the burners instead of *outside*. Once lit, if you hear a 'whooshing' sound, immediately turn the burner knobs OFF to extinguish the flame. Wait 1 minute and then re-light the burners.



USE CAUTION WHEN OPENING OR REMOVING THE DOOR

The oven door and handle can become very hot and may cause injury. Use oven grade insulated gloves or mitts and utensils when handling the door.

BAKING IN WINDY CONDITIONS

Outdoor cooking can create more heat than interior kitchen ranges.

These high-performance burners require a constant, steady supply of fresh air to mix with the fuel. Your Lynx oven pulls air in through the front and vents hot gases out through the vent stack.



Air enters through the front of the oven.

Using your oven in windy conditions may disrupt the air flow. If, while using your oven burners on high and the door closed, you notice that the temperature gauge fails to rise ... be careful. If wind has kept hot gases from exiting the rear of the oven the control panel and knobs may have become extremely hot.

Your Napoli pizza oven is provided with a reversible oven exhaust vent which can be configured to vent to the front or to the rear. The stack can be repositioned to minimize wind disruption.



To reverse the exhaust vent direction simply lift the vent from the oven mounting position and turn it around to face the opposite direction. The vent will rest in place without the use of fasteners. Be sure oven is off and cooled before reversing the vent stack.

NOTE: Do not operate the oven with the exhaust vent removed.

But there are a few things you can do to further **prevent the possibility of improper heat buildup:**

- If you suspect the oven is overheating, using an oven mitt, open the front door. Then adjust the burner control knob to a lower setting.
- Install your oven with a wind break behind it.
- Reposition the exhaust stack to face away from the prevailing wind.

Please Note: Any damage caused from use in windy conditions, such as melted knobs or igniter wires, or control panel discoloration from heat buildup, is excluded from warranty coverage.

USING YOUR LYNX PIZZA OVEN

Best results are achieved when the pizza oven is allowed to preheat a minimum of 35 minutes with the door closed for best performance. Allow a little more time for colder ambient temperatures.

With the burners on high the pizza oven internal temperature can reach 700 °F to 800 ° F. After preheating, a medium high setting is an ideal temperature for preparing thin and medium crust pizza. Cooking time will be approximately 4 minutes and remember to rotate the pizza often for even heating.

With the burners set from medium to low the internal temperature can reach 300°F to 500°F. This is suitable for cooking medium to deep dish pizzas, calzones, roasts and slow baked items. Cooking times will be 8 to 10 minutes. Remember to rotate your pizzas a couple times during baking for even doneness. Thick pizzas can take up to 20–30 minutes depending on the thickness of the dough.

Avoid baking greasy or fatty food directly on the oven deck. When preparing these types of meals cooking utensils, such as cookie sheets, pots and pans, should be used.

When cooking roasts and vegetables it is best to preheat your cooking utensils prior to placing in the oven.



PRE-BAKE CHECKLIST

BEFORE YOUR *FIRST* USE

There are a few must-check safety precautions to consider before you use your oven. Please be sure that:

- All packing materials and tie-downs have been removed. (See INDEX: “Unpacking and Assembly” for further details.)
- You have fuel connected. (See INDEX: “Gas Requirements” for further details.)
- You have electricity connected. (See INDEX: “Electric Requirements” for further details.)
- A qualified plumber has performed a leak test on all the fittings that supply fuel to your oven.
- **IF YOUR OVEN DOES NOT LIGHT IN 4 TO 5 SECONDS** you may need to purge the line. (See INDEX: “Purging the Gas Line”)

AT EACH NEW SEASON

At the start of each new outdoor cooking season you should remove and check the venturis, orifices and valves for obstructions.

Spiders and insects often nest in these areas of the oven and can disrupt air flow, causing damage to the oven and personal injury.

Also, check all hoses and fittings for damage, abrasion, wear and tear.

BEFORE EACH USE

Before any use, always make sure that:

- ... you do not smell gas before you light the oven. If you do smell gas, shut everything off and have a qualified plumber check for leaks.
- ... the cooking area is free and clear of any combustibles, besides your food, that might ignite.
- ... the control knobs turn freely.
- ... if you are using a portable propane cylinder, it is securely connected and leak tested. (See INDEX: “Cylinder Retention Instructions” for details.)
- ... you know where the main gas supply shut-off is located.
- ... the burners are seated properly in the oven. The main burners must sit flush and firmly on the burner mounting support frame. (See INDEX: “Unpacking and Assembly” for further details.)
- ... wind is not blowing too strongly or blowing on the front of oven.

COOKING SUGGESTIONS

NO-COOK PIZZA SAUCE

1 28 oz. Can of San Marzano Tomatoes. Do not drain, use tomatoes and liquid.

1 Tsp Salt

1/2 Tsp Sugar

1 Tsp Minced Garlic

1 Tsp Oregano, dry

1 Tbsp Basil, fresh, finely chopped

Directions for Pizza Sauce:

1. Blend all ingredients in a blender, except for basil.
2. Mix in freshly chopped basil and store in an air tight container in the fridge until needed.

PIZZA DOUGH

Makes 1 large pizza.

1 teaspoon yeast

1/2 cup warm water (around 110 degrees F)

1 1/2 cups all-purpose flour

2 teaspoons sugar

1 teaspoon salt

2 tablespoon extra virgin olive oil plus 1 teaspoon for coating

Directions for Dough:

1. Pour water in an electric mixer's bowl and dissolve the yeast in the water and set aside for 5 minutes.
2. Pour in all the remaining ingredients and mix on the 2nd lowest setting using the hook attachment for 2 to 3 mins until the dough is smooth.
3. Oil the dough and the interior of the mixing bowl. Place the dough ball back in the bowl and cover it with plastic wrap. Let dough rise at room temperature for 2 hours.
4. Punch down the dough, form a round ball again with the dough and return it to the same bowl, cover again and let it rise for 1 more hour. Dough is ready to be used.
5. Pre-heat pizza oven to 600 F. Build your pizza with pizza sauce, fresh mozzarella cheese and your favorite toppings. Pizza should cook for about 5 minutes or until lower crust is set and crispy.

Enjoy!

COOKING SUGGESTIONS ...*continued*

Make sure the oven is properly preheated before cooking your pizza to prevent sticking to the pizza deck. Similarly, do not use frozen pizza in the oven to prevent sticking and overcooking.

Pizzas should not be prepared until ready to go into the oven. Pizzas allowed to sit will tend to stick to the pizza peel or counter top.

Cook most medium and smaller pizzas directly on the oven deck at higher temperature for 4 to 8 minutes.

Larger and thicker pizzas can be cooked on a pizza rack or pizza pan at lower temperature for longer bake times.

Keep pizzas centered in the oven for best results

Using excessive toppings on pizzas may result in overcooking before the toppings are done, or soggy pizza centers.

To prevent pizza dough from sticking to the pizza peel or the oven deck use corn meal or flour spread on the deck and peel surfaces. Be sure to brush away any remaining corn meal or flour from the oven deck prior to cooking another pizza.

During cooking rotate the pizzas often to achieve uniform doneness. Use the pizza peel or long handled tongs. Tongs are useful to lift the pizza to check for crust doneness.



LIGHTING YOUR OVEN



WARNING

1. Never attempt to light a burner if you smell gas.
2. Remove the oven door, or pull out the baking tray when lighting your pizza oven.
3. Releasing fuel into a closed oven before lighting will increase the risk of explosion, property damage, personal injury or death.
4. Keep your face and body as far from the oven as possible when lighting. Any time a burner doesn't light within 5 seconds, turn off the control, wait 5 minutes for gas to dissipate, and repeat the lighting procedure.
5. YOU NEVER LEAVE THE OVEN UNATTENDED WHILE COOKING.

ELECTRIC IGNITION

Before proceeding, make sure you have completed the "Before Each Use" checklist.

Follow these steps to light any of the burners on your oven:

First, make sure all burner control knobs are set to OFF.



The oven burner features a thermocouple sensor with a safety valve that automatically shuts off the flow of gas if the burner goes out.

To light the oven burner, push and hold the control knob in for 2 seconds and then turn the knob to the "LITE" position.

The burners can be manually lit with a kitchen match in the event of an ignitor failure. Light a kitchen match and hold it at the front edge of the burner and turn the gas control knob to the light position.

After ignition CONTINUE HOLDING THE CONTROL KNOB IN for 10 to 20 seconds. During this time the thermocouple will heat up and the safety valve will remain open.

If you release the control knob before the thermocouple has heated up, the safety valve will shut off the flow of gas to the oven burner and you will have to re-light the burner.

CLEANING YOUR LYNX OVEN

STAINLESS STEEL

Lynx products are known for their attractive appearance. We achieve this by selecting only the finest grades of stainless steel and applying exacting workmanship.

In order to maintain this attractive appearance over the life of the oven it is important to take the following steps:

- After each use wipe down the exterior of the oven to remove grease and splatters.
- Be sure to follow the cleaning instructions for keeping the cooking surface clean and ready for use.
- Use a commercially available Stainless Steel cleaner to clean and polish the exterior surfaces.

Doing these things on a regular basis minimizes the amount of effort required.

Part of the appeal of your Lynx oven is the fine grain finish. When removing stubborn stains:

- Do not use metallic abrasives and always rub in the direction of the grain.



- Some household cleaning products are not suitable for stainless steel; be sure to read the label before using on your Lynx oven.
- Always use the mildest cleaning solution first, scrubbing in the direction of the grain. Specks of grease may gather in the grain of the stainless steel and bake on to the surface, giving the appearance of rust.

To remove these baked-on foods use a fine to medium grit non-metallic abrasive pad (Scotch Brite is good) in conjunction with a stainless steel cleaner.

- **Solutions used for cleaning concrete and masonry can be very corrosive and will 'attack' stainless steel. Ensure your Lynx products are well protected before you allow the use of such chemicals near your oven.**

SPECIAL NOTE FOR LOCATIONS NEAR POOLS AND COASTAL AREAS

The 304 stainless steel material used in the construction of a Lynx oven is highly rust resistant, however, chlorine in the air from swimming pools or the salt from sea air may cause surface rust to appear and even create some pitting if left on the product.

Here are a few tips to avoid this:

- Regularly wipe down the exterior surfaces with a damp cloth. (Micro fiber cloths such as Ecloth perform very well).
- Allow the surfaces to dry before installing the cover. Do not cover a damp oven.
- In extreme environments apply a rust inhibitor which leaves a microscopic protective layer on the oven. Products that provide a layer of vapor corrosion inhibitors (VpCI™) protect the surface very well.
- For seasonal storage use the product referred to above, ensure the oven is dry and then cover and secure the cover to minimize the amount of damp air getting to the surfaces.

THE LYNX LIMITED LIFE TIME WARRANTY PROVIDES PROTECTION AGAINST RUST THROUGH OF PARTS THAT RENDER THE PRODUCT INOPERATIVE. IT DOES NOT COVER OCCASIONAL SURFACE RUST OR STAINING DUE TO ENVIRONMENTAL CONDITIONS.

After your first use certain areas of the oven may discolor from the intense heat given off by the burners - this is normal and cannot be cleaned off.

For light and heavy food stains there are many different stainless steel cleaners available.

TROUBLESHOOTING YOUR LYNX OVEN

BEFORE YOU CALL FOR SERVICE

Please check a few things before calling for service:

- Is there fuel supplied to the oven?
- Is the main shut-off valve open?
- Are you using the correct type of fuel? (LP or Natural Gas) (See INDEX: "Gas Requirements" for further details.)

- Is your propane cylinder empty? Have you recently refilled the propane cylinder? If so, is the connection tight?
- Have you opened the valve on the propane cylinder?
- Is the oven plugged in to a live electric circuit?

If you've checked the above items, review the troubleshooting list below before calling for Lynx for service.

POTENTIAL PROBLEMS

OVEN WON'T LIGHT

First, confirm that the oven is getting electricity by turning on the lights, then:

Check The Igniters

Your Lynx oven uses an electric ignition system that does not spark. Instead, the igniters will glow constantly when a control knob is turned ON.

- Ensure that all burners are set to OFF.
- Remove the oven door, or pull open the drawer.
- Turn the burner knob ON and wait approximately 1 minute for the igniter to glow.
- Check all igniters. If they do not glow, proceed with trouble shooting.

Check The Burners

If the igniters are working check to see if gas is reaching the burners by attempting to match light a burner.

BE CAREFUL! IF THE BURNER FAILS TO IGNITE, WAIT 5 MINUTES BEFORE ATTEMPTING TO IGNITE OTHER BURNER! (See INDEX: "Match Lighting" for further details.)

If match lighting doesn't work, re-check fuel connections for leaks and ensure the supply is of the correct type and is of adequate pressure. (See INDEX: "Leak Test Procedure" for further details.)

If the burner will light with a match, then the igniter may not be functioning correctly. Call for service.

If the burner will not match light, and you know you are getting gas, wait for any gas to dissipate and remove the burner and check it for blockages.

SMELL OF GAS WHILE COOKING

IF YOU SMELL GAS WHILE THE OVEN IS OPERATING, IMMEDIATELY TURN OFF ALL BURNERS AND SHUT OFF THE MAIN FUEL SUPPLY.

- Perform a leak test (See INDEX: "Leak Test Procedure" for further details.)
- Check for blockages

POTENTIAL PROBLEMS ...continued

LOW OR INSUFFICIENT HEAT

Ensure that you've preheated the burner(s) for at least 20 to 35 minutes with the door closed.

Proper leveling during installation is critical. An oven that is out of level will cause erratic burner combustion and inefficient, uneven heating. A carpenter's spirit level should be used to level the oven both front-to-back and side-to-side.

If the low heat problem persists:

- Check the gas supply line sizing requirements.
- Check the gas supply line for kinks or damage.
- Check the burner control for proper operation.

REPLACE any damaged supply lines.

- Check the Regulator

Make sure that the regulator & hose assembly is the one designed for and supplied with your Lynx oven and that it is correctly set up for the type of fuel you are using. (See INDEX: "Regulator Conversion" for further details.)

The hose and regulator provided by Lynx must be used if your oven is set-up for an LP Gas Cylinder.

Check that there is no physical pressure being applied to the regulator attached to the back of the oven. The regulator contains a flexible diaphragm and should not be allowed to touch the oven body or its surroundings.

- Check for Obstructions

Ensure that the burners are clean and free from obstructions.

LP (Propane) units:

- Is the cylinder almost empty?

Almost-empty cylinders may not have sufficient pressure to run the burners at high heat.

- Have the line pressure checked by a qualified technician (See INDEX: "Gas Requirements" for further details.)
- Flow Limiting Device

Improper lighting procedures may have activated the LP cylinder's flow control device, reducing the heat output.

To reset the flow control:

- Shut off all burner controls and close the LP cylinder valve.
- Wait 30 seconds and, very slowly, reopen the cylinder valve.
- Wait a few seconds and relite a burner.

Bulk LP Cylinder Users

Bulk LP cylinder lines must be properly regulated.

Ensure that you are using a 4/11 appliance regulator supplied by Lynx and converted to LP gas. Also ensure that you do not have more than one regulator in line.

Natural Gas units:

- Supply Line

Ensure that the supply line is at least 3/4" inside diameter or 1" outside diameter.

- Check line pressure

Natural gas inlet pressure should be at least 7" W.C. and manifold pressure not less than 4" W.C. under full load (with all burners on.)

- Check burners for blockages
- Check flame characteristics. (See INDEX: "Flame, Correct Size")

LIGHTS WON'T LIGHT

- Check Power

Ensure that the oven is connected to a live AC power source.

- Reset Transformer

Disconnect power from the oven and wait 5 minutes for the transformer to cool down and reset. Then reconnect power. If, after resetting the transformer and replacing bulbs, you still do not have power, call for service.

- Replace the Bulb

Replacement bulbs are halogen, 12 volt, 10W max, T3 type with a G4 bi-pin, and are readily available at most stores. The glass cover is held



POTENTIAL PROBLEMS ...*continued*

in place by two spring tension tabs. The bulbs are easily removable without the use of tools. Simply grasp the glass lens at the outer corners, near the front tension clips and push the lens back. Then, swing the lens down and pull it loose. You may have to loosen the screw to remove the lens.

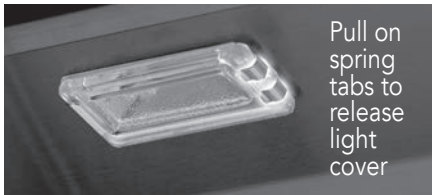

Avoid touching the glass of a new bulb. Halogen bulbs are very sensitive to the oils found in human skin. Touching the bulbs may shorten their life.

Pull the bulb straight out from the socket without twisting.

Hold the bulb using a paper towel or other cloth and gently press it straight into the socket. The glass cover should be gently snapped back into place.

CONTACTING LYNX CUSTOMER CARE

Before calling Lynx Customer Care, please make sure you have the following information:

- Model number
- Date of purchase
- Proof of purchase by the original owner
- Serial number

The serial number can be located on the rating plate which is located in this Care and Use Manual, and on the bottom of the oven enclosure. Pull out the bottom cooking deck to access the rating plate.

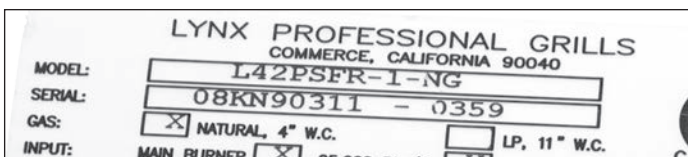

For warranty service, contact the Lynx Customer Care Department for an authorized service agent near you at:

(888) 289-5969

www.lynxgrills.com

Your satisfaction is of the utmost importance to us. If a problem cannot be resolved to your satisfaction, please write, fax or email us:

Lynx Professional Grills

7300 Flores Street

Downey, CA 90242

Service: (888) 289-5969

Tel: (562) 299-6900

Fax: (562) 299-6978

www.lynxgrills.com

Contact Lynx for replacement parts. Parts are shipped F.O.B. Downey, CA.

THE LYNX STORY

Lynx began with a vision.

A small group of manufacturing engineers with over a century of collective experience had a dream. They dared to take their extensive commercial manufacturing know-how and create a line of outdoor cooking products that offer commercial elegance and performance to the consumer market.



Lynx has taken the quality, workmanship, service and innovation of the commercial market and incorporated it into the Lynx Professional Grills line of consumer and commercial products. The combination of creative design, superior materials and exceptional craftsmanship elevates Lynx products to a class of their own.

Lynx original commercial products are used every day in restaurants, hotels and theme parks across the USA:

LYNX SATISFIED CUSTOMERS

- TGI Fridays
- Applebee's
- Houston's
- Red Lobster
- Hard Rock Café
- Wolfgang Puck's
- Cheesecake Factory
- Red Robin
- Planet Hollywood
- Hilton
- Hyatt
- Four Seasons Marriott
Le Meridian
- Sheraton
- Conrad International
- Bellagio
- New York New York
- MGM Grand
- Treasure Island
- Mirage
- Paris
- Venetian
- Excalibur
- Mandalay Bay
- Riviera
- Desert Inn
- Hard Rock Hotel
- Disney World

LYNX LIMITED WARRANTY

I. Limited Lifetime Warranty

The stainless steel body and the burners are warranted to be free from defects in material and workmanship when subjected to normal domestic use and service for the life of the original purchaser. This warranty excludes surface corrosion, scratches, and discoloration which may occur during normal use. This warranty is limited to the replacement of the defective parts, with the owner paying all other costs including labor, shipping and handling.

II. Limited Five-Year Warranty

The following oven parts are warranted to be free from defects in material and workmanship, when subjected to normal domestic use and service, for a period of five (5) years from the original date of purchase; manifolds, gas valves and refractory dome and base. This warranty is limited to the replacement of the defective parts, with the owner paying all other costs including labor, shipping, and handling.

III. Limited Two-Year Warranty

All other oven components are warranted to be free from defects in material and workmanship, when subjected to normal domestic use and service, for a period of two (2) years from the original date of purchase. This warranty is limited to the replacement of the defective parts, with the owner paying all other costs including labor, shipping and handling.

IV. Limited One-Year Warranty.

For a period of one (1) year from the original date of purchase, Lynx will replace or repair parts found to be defective at no cost to the original purchaser. This includes the cost of shipping replacement parts and, where necessary, service labor at prevailing local rates by a Lynx authorized service person. Service will be provided during normal business hours and must be authorized in advance by Lynx.

IV. Limitations & Exclusions

- 1) This Warranty shall apply to products purchased and located in the United States and Canada. Products must be purchased in the country where service is requested.
- 2) Warranty applies only to the original purchaser and may not be transferred.
- 3) Warranty is in lieu of all other warranties expressed or implied and all other obligations or liabilities related to the sale or use of its oven products.
- 4) Warranty shall not apply and Lynx is not responsible for damage resulting from misuse, abuse, alteration of or tampering with the appliance, accident, hostile environment, flare-up fires, improper installation, or installation not in accordance with the instructions

contained in this manual, or the local codes.

- 5) Lynx shall not be liable for incidental, consequential, special or contingent damages resulting from its breach of this written warranty or any implied warranty.
- 6) Some states do not allow limitations on how long an implied warranty lasts, or the exclusions of or limitations on consequential damages. This warranty gives you specific legal rights and you may have other rights which vary from state to state.
- 7) No one has the authority to add to or vary Lynx's warranty, or to create for Lynx any other obligation or liability in connection with the sale or use of its products.
- 8) Limited to the replacement of defective parts with the owner paying all other costs including labor.
- 9) *This Warranty does not apply to normal wear and tear. Note that all refractory materials will form small cracks over time. These cracks will not affect the performance of the oven.*

V. What is not covered: Lynx shall not be responsible for and shall not pay for the following:

- 1) Installation or start-up, damages or problems caused by improper installation or use;
- 2) Service by an unauthorized service provider;
- 3) Damage or repair due to service by an unauthorized service provider or use of unauthorized parts;
- 4) Warranty does not apply to products installed in any commercial or non-residential application. Examples of excluded applications include, but are not limited to day care centers, schools, bed and breakfast centers, churches, private clubs, fire stations, club houses, common areas in multi-family dwellings, restaurants, hotels, nursing homes, food service locations and institutional food service locations.
- 5) To correct normal adjustments or settings, due to improper installation, commissioning or local gas supply properties.
- 6) Shipping and handling costs, export duties, installation, removal, or re-installation cost.
- 7) Display models are sold "as is". If you have purchased a display model, please be advised that it is sold "as is" and that it is subject to the following warranty exclusions: any exterior or cosmetic damage is non-warrantable; any missing components will be replaced at consumer's expense; major handling damage to manifold, valve and ignition system will be serviced at consumer's expense; all other warranty's (standard warranty) will remain in effect.
- 8) The cost of a service call to diagnose trouble.

LYNX COMMON AREA LIMITED WARRANTY

The Lynx Limited Warranty covers residential installations only and is non-transferable to any other party. This 'non-residential' warranty applies when the product is installed in common areas where more than a single party has rightful access to its use or in locations considered beyond normal residential use such as B&B's, and private clubs.

THIS PROVISION EXCLUDES ALL COMMERCIAL APPLICATIONS, INCLUDING, BUT NOT LIMITED TO RESTAURANTS AND INSTITUTIONAL FOOD SERVICE LOCATIONS.

I. Limited Five-Year Warranty

The stainless steel body and the burners and the refractory dome and base are warranted to be free from defects in material and workmanship when subjected to normal domestic use and service for a period of 5 years from the date of purchase of the original purchaser. This warranty excludes surface corrosion, scratches, and discoloration which may occur during normal use. This warranty is limited to the replacement of the defective parts, with the owner paying all other costs including labor, shipping and handling.

II. Limited One-Year Warranty

The structural integrity of the interior oven parts, exterior, and drip pans are warranted to be free from defects in material and workmanship, when subjected to normal domestic use and service, for a period of one year from the date of purchase. This warranty is limited to the replacement of the defective parts, with the owner paying all other costs including labor.

III. Limited Parts & Labor Warranty

All other oven components are warranted to be free from defects in material and workmanship for a period of 90 days from the original date of purchase. Lynx will replace or repair parts found to be defective at no cost to the original purchaser. After the 90 day period Lynx will sell parts to the holder of this warranty at Lynx contractor prices for an additional 9 months.

IV. Limitations & Exclusions

- 1) This Warranty shall apply to products purchased and located in the United States and Canada. Products must be purchased in the country where service is requested.
- 2) Warranty applies only to the original location of installation and may not be transferred.
- 3) Warranty is in lieu of all other warranties expressed or implied and all other obligations or liabilities related to the sale or use of its oven products.

- 4) Warranty shall not apply and Lynx is not responsible for damage resulting from misuse, abuse, alteration of or tampering with the appliance, accident, hostile environment, flare-up fires, improper installation, or installation not in accordance with the instructions contained in this manual, or the local codes.
- 5) Lynx shall not be liable for incidental, consequential, special or contingent damages resulting from its breach of this written warranty or any implied warranty.
- 6) Some states do not allow limitations on how long an implied warranty lasts, or the exclusions of or limitations on consequential damages. This warranty gives you specific legal rights and you may have other rights which vary from state to state.
- 7) No one has the authority to add to or vary Lynx's warranty, or to create for Lynx any other obligation or liability in connection with the sale or use of its products.
- 8) Limited to the replacement of defective parts with the owner paying all other costs including labor.

V. What is not covered: Lynx shall not be responsible for and shall not pay for the following:

- 1) Installation or start-up, damages or problems caused by improper installation or use;
- 2) Service by an unauthorized service provider;
- 3) Damage or repair due to service by an unauthorized service provider or use of unauthorized parts;
- 4) To correct normal adjustments or settings, due to improper installation, commissioning or local gas supply properties;
- 5) Shipping and handling costs, export duties, installation, removal, or re-installation cost.
- 6) Display models are generally sold "as is." If you have purchased a display model, please be advised that it is sold "as is" and that it is subject to the following warranty exclusions: any exterior or cosmetic damage is non-warrantable; any missing components will be replaced at consumer's expense; major handling damage to manifold, valve and ignition system will be serviced at consumer's expense; all other warranty's (standard warranty) will remain in effect.
- 7) The cost of a service call to diagnose trouble.

WARNINGS



WARNING

1. Always maintain the required clearances from combustible construction as detailed. The oven is designed for outdoor use only. Never use in a garage, building, shed, breezeway or other enclosed area. This oven shall not be used under any unprotected overhead combustible construction.
2. Gas ovens are not design certified for and are not to be installed in or on recreational vehicles, portable trailers, boats or any other moving installation.
3. Keep any electrical supply cord and the fuel supply hose away from any heated surfaces. Electrical cords should be placed away from walkways to avoid creating a tripping hazard.
4. Do not repair or replace any part of the oven unless specifically recommended in this manual. Other service should be performed by a qualified technician.
5. All gas lines must have a shut-off that is readily and easily accessible. Be sure the owner knows where the shut-off is located. If you smell gas, check for gas leaks immediately. Check only with a soap and water solution. Never check for gas leaks with an open flame. (See INDEX: "Leak Testing" for further details.)



WARNING

1. The outdoor cooking gas appliance and its individual shutoff valve must be disconnected from the gas supply piping system during any pressure testing of that system at test pressures in excess of 0.5 psi (3.5 kPa).
2. The outdoor cooking gas appliance must be isolated from the gas supply piping system by closing its individual manual shutoff valve during any pressure testing of the gas supply piping system at test pressures equal to or less than 1/2 psi (3.5 kPa).



STATE OF MASSACHUSETTS

1. Massachusetts requires all gas be installed using a plumber or gas fitter carrying the appropriate Massachusetts license.
2. All permanently-installed natural gas or propane installations require a "T" handle type manual gas valve be installed in the gas supply line to this appliance.
3. This does not apply to portable propane installations using a 20 pound cylinder.

BEFORE YOU START



WARNING

- Never locate the oven under a roof or overhang, in a building, garage, shed or other such enclosed area.
- Never locate the oven under any unprotected combustible construction.
- Installation must conform with local codes or, in the absence of local codes, with either the National Fuel Gas Code, ANSI Z223.1/NFPA 54, Natural Gas and propane Installation Code, CSA B149.1, or Propane Storage and Handling Code, B149.2, in Canada.

IF SHIPMENT ARRIVES DAMAGED

VISIBLE LOSS OR DAMAGE

Be certain any visible damage to the carton is noted on freight bill or express receipt and signed by the person making delivery.

FILE CLAIM FOR DAMAGES IMMEDIATELY, regardless of extent of damage.

CONCEALED LOSS OR DAMAGE

If damage is unnoticed until the oven is unpacked, notify the transportation company or carrier immediately and file a "concealed damage" claim with them. This should be done within (15) days of the date delivery is made to you. Be sure to hold on to the container for inspection. We cannot assume responsibility for damage or loss incurred in transit. (See INDEX: "Obtaining Service from Lynx" for further details.)

Shipping receipts should be signed "not inspected for concealed damage."

IMPORTANT NOTES

HOW LONG IS YOUR RUN?

Keep all gas supply lines as short as possible because gas lines lose pressure over distance and with each elbow and tee that is added. This drop in pressure affects oven performance. (See INDEX: "Gas Supply Line Runs" for further details.)

ARE YOU "ON-THE-LEVEL"?

Proper leveling during installation is critical. An oven that is out of level will cause erratic burner combustion and inefficient, uneven heating. A carpenter's spirit level should be used to level the oven both front-to-back and side-to-side.

If the floor is uneven or has a decided slope, re-leveling may be required each time you move a freestanding unit.

UNPACKING & ASSEMBLY

The oven arrives nearly ready to use and requires only minor assembly.

By carefully following the uncrating and unpacking steps, you will improve the customer's first Lynx experience.

Shipping weight on smaller units is app. 300 pounds and larger units may weigh over 500 pounds.



WARNING: EXCESSIVE WEIGHT HAZARD!

Use two or more people to move or install this unit. Failure to follow this instruction can result in back or other personal injuries.

CRATE & CARTON

- **IMPORTANT!** Do not remove staples around the top of the carton. These staples hold a wooden pallet in place inside the carton that protects the unit from damage. Removing these staples may cause the pallet to fall on the top of oven.

The LPZA Pizza oven can be used as a freestanding model when used with the LPZAF cart assembly (available separately).

The cart assembly comes fully assembled and provides a convenient counter space to mount your oven. The oven is mounted on the counter top without the use of fasteners and provides ample counter space and storage space for all of your tools and accessories.

How to Remove the Carton

1. Cut the main strap holding the oven to the pallet.
2. Remove the staples at the bottom of the carton.
3. Lift off the carton.
4. With assistance, remove the oven from the pallet and place into desired location.

The wheels of the LPZAF cart sit down in the gaps of the shipping crate so the cart can sit safely and solidly on the crate during shipping. The cart cannot be slid directly off of the pallet.

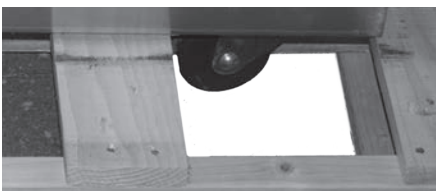

Cart will not slide directly off pallet.

One way to safely move the cart off of the pallet is by lifting one end of the oven high enough to place a ramp under the wheel and then lift the other end while rolling the oven off of the pallet.



INTERIOR PACKING

Lynx uses sturdy tie-down cables and straps to ensure your oven arrives at your home in the same condition that it left our factory. **BE SURE YOU HAVE REMOVED ALL TIE DOWNS BEFORE USING YOUR OVEN.**

Remove any loose items from the packaging and firebox.

BEFORE YOU START ...*continued*

BUILT-IN INSTALLATIONS

The Lynx Built-In oven is designed for easy installation into masonry enclosures.

NOTE: Lynx pizza ovens are intended for installation in a built in masonry enclosure or mounted to a non-combustible counter or the optional LPZAF freestanding cart.

For built-in applications the oven drops into the opening shown in the specifications and installation details drawing. A deck is required to support the oven from the bottom.

The enclosure should have ventilation holes to prevent LP gas build-up in the event of a leak. The deck ledges and counter should be flat and level. (refer to ANSI Z21.58 Standard for Outdoor Cooking Gas Appliances, Section 1.7 Enclosures For Self Contained LP-Gas Supply Systems)

This oven requires that a 120 volt, 60 hertz, 15 amp GFI certified outlet be installed by a qualified electrician.

CLEARANCE TO COMBUSTIBLE MATERIALS

Minimum clearance from the sides and back of the oven to adjacent combustible construction below the top of unit are 0" from the sides and back.

Dégagement minimal entre les parois latérales et l'arrière de l'appareil et la construction combustible au-dessous du panneau supérieur de l'appareil (0 cm à partir des parois latérales et 0 cm à partir de l'arrière).

Minimum clearance from sides and back of unit to adjacent combustible construction extending above the unit is 18" from the sides and back.

Dégagement horizontal minimal entre les parois latérales et l'arrière de l'appareil et la construction verticale combustible au-dessus de l'appareil (45.7 cm à partir des parois latérales et 45.7 cm à partir de l'arrière).

Do not use this appliance under unprotected overhead combustible surfaces.

Ne pas utiliser cet appareil en-dessous de surfaces combustibles non protégées.

OVERHEAD PROTECTION AND EXHAUST REMOVAL

Do not install this appliance under any *unprotected* overhead combustible construction. If installed under any combustible construction the cooking area over the oven must be covered with an exhaust hood. The hood must provide 3 to 6 inches of overhang on all exposed sides. The exhaust hood shall provide no less than 1200 CFM for proper exhaust ventilation. The hood must be approved for outdoor installation and provided with a dedicated GFCI protected branch circuit.



SPECIFICATIONS & INSTALLATION

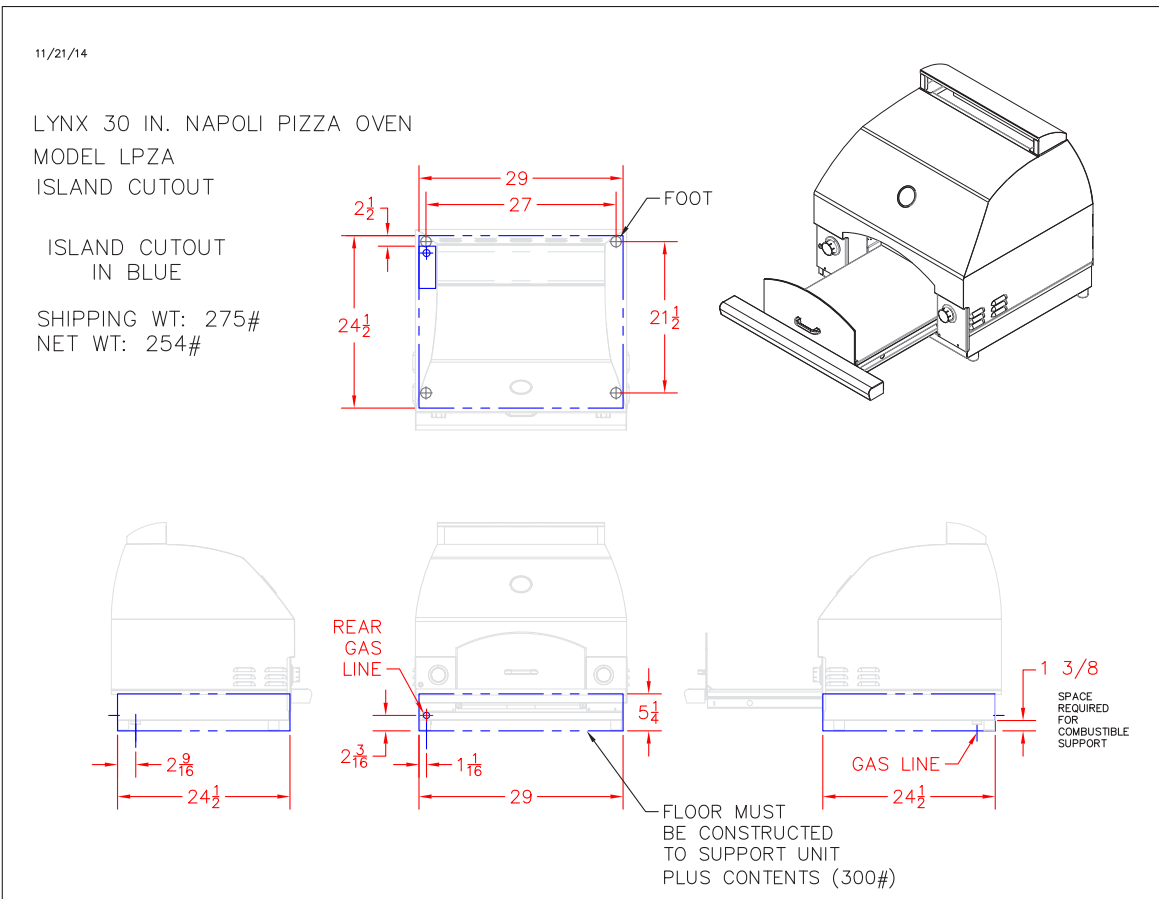
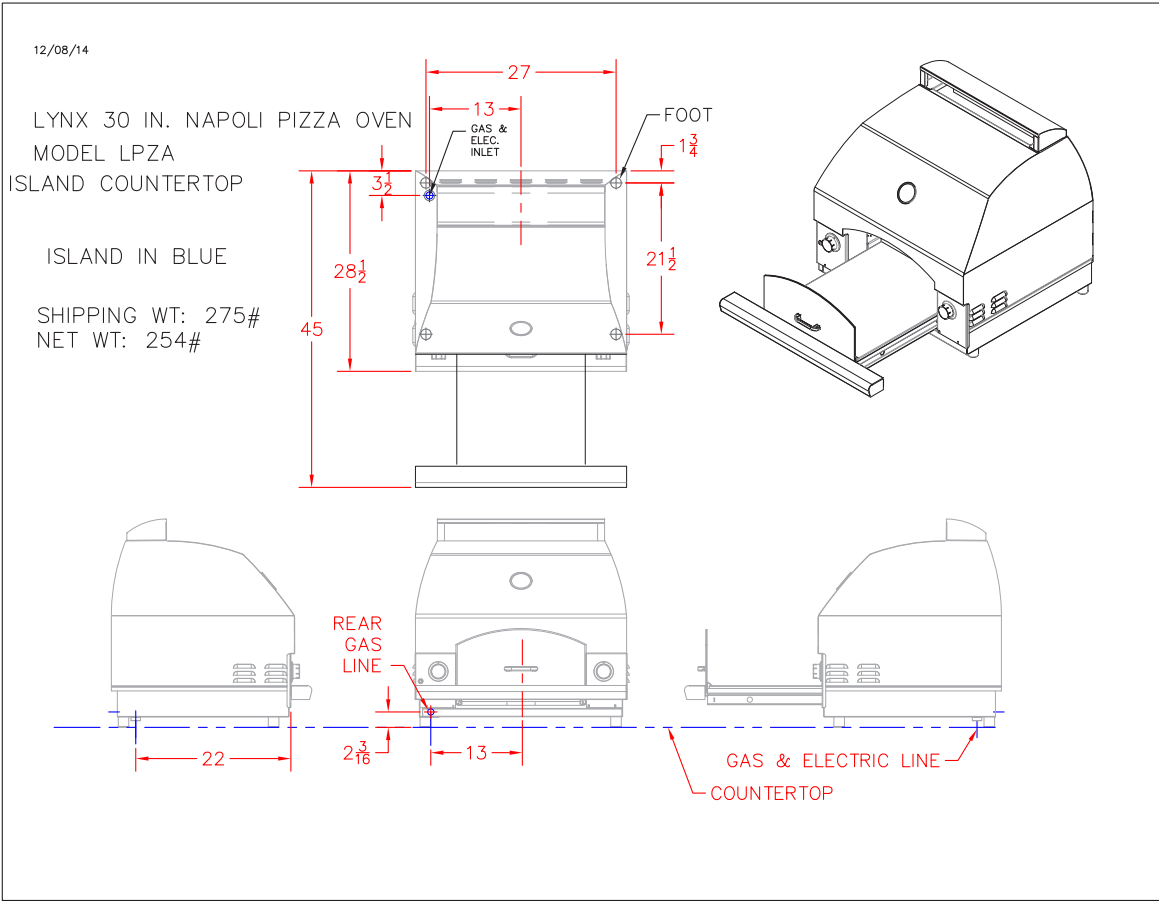

GAS CONNECTIONS



WARNING

NEVER CONNECT A GAS LINE DIRECTLY TO THE OVEN. A PRESSURE REGULATOR MUST BE INSTALLED ON ALL GAS EQUIPMENT. ALL LOCAL CODES REQUIRE IT AND LYNX SUPPLIES THE CORRECT REGULATOR WITH YOUR OVEN. REMOVING OR FAILING TO INSTALL THE PRESSURE REGULATOR CAN RESULT IN FIRE AND SERIOUS PERSONAL INJURY AND WILL VOID THE WARRANTY.

The oven is factory set to use either propane (LP) or natural gas (NAT). It is critical that the gas you use matches that which the oven was set up for. You can verify that by checking the **rating plate**.

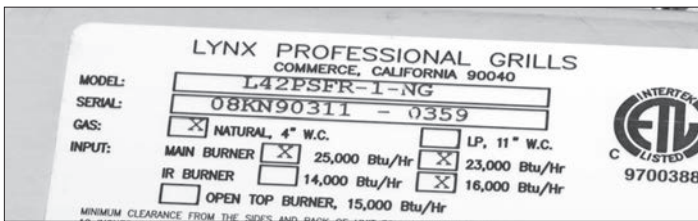

The Rating plate lists serial numbers, model numbers and gas type.

The rating plate is located in one or more of the following places:

- Attached to the inside bottom of the oven assembly once the cooking drawer is opened and the deck removed.
- On the back of the Care & Use Manual

Ensure that the gas supplied meets with the minimum pressure requirements. Do not operate the oven on any gas other than that for which the oven has been set.

Fuel	WC Max Inlet	WC Min Under Full Load
Nat Gas	7 in	4 in
LP	14 in	11 in

Water Column Requirements

Both the regulator and the manifold orifices have been tuned for the type of gas specified on the rating plate.

Converting to a different type of gas requires a conversion kit, available from Lynx or from your dealer and must be installed by a qualified technician.

All installation and all installation parts must conform to local codes with the National Electrical Code, ANSI Z223.1/ NFPA 70 latest edition and the National Fuel Gas Code, ANSI Z223.1/NFPA 54 in the U.S. and CGA-B149.1/.2 in Canada.

Canadian installations must conform to CGA-B149.1/.2 natural gas/propane installation code. (Canada)

NATURAL GAS

Lynx recommends that only qualified professionals perform the required plumbing on this product.

To ensure satisfactory performance, the gas supply line must be sized to accommodate the total BTU requirements of all the gas-fired equipment that will be connected to that line.

In no case should pipe less than 3/4" inside diameter or 1" outside diameter ever be used to connect this product.

- Calculate the total BTU output of all equipment and refer to "INDEX: Gas Supply Line Runs" for allowable run distances for 3/4 inch pipe. Failure to meet these minimum requirements may reduce performance of the oven and any other appliances running on that supply line.
- Always keep supply line runs as short as possible. (See INDEX: "BTU Output" for specific model outputs)
- A gas shut-off valve must be installed in an easily accessible location by a qualified plumber.
- Keep threading compound off of the first two pipe threads to avoid having any small pieces of compound break loose and clog a burner valve or orifice. Do not use threading compound on any flare fittings.

Keep last two threads clean

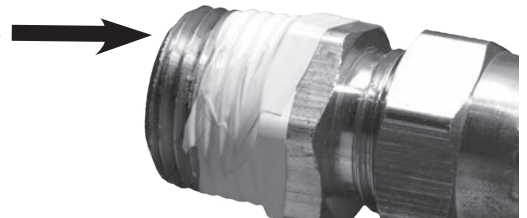

For built-in installations, it is recommended that any flexible pipe used be kept as short as possible. (See INDEX: "Gas Connections" for typical permanent hook up.)

For freestanding units using natural gas, Lynx strongly recommends using a quick disconnect kit.

GAS CONNECTIONS ...continued



This Quick Disconnect kit, part #LQD, is available from your dealer.

LP GAS

Ovens set up for LP gas come equipped with an LP hose/regulator assembly for connection to a standard 20 lb. LP cylinder. (Type 1). All fittings necessary to attach the assembly to the oven are included.

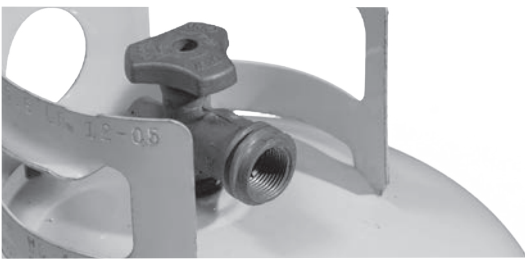

LP cylinder with type 1 valve connection

Permanently plumbed LP connections, such as those in line with a bulk cylinder, require a 4/11 regulator. (Lynx P/N 30781)

When using the 4/11 regulator you must ensure that it is set for the proper fuel type. This is done by removing the regulator cap and gasket and looking at the bottom of the plunger to see what fuel type is visible. This is the regulator fuel setting. NAT is for natural gas and LP is for propane gas. The LP setting can be further identified by the large diameter disk on the bottom of the plunger. To change from one gas to the other simply push the plunger to the side to snap it out of the cap, turn the plunger so it reads the desired gas type on the bottom, and push the plunger until it snaps back into place in the cap then replace the cap into the regulator.

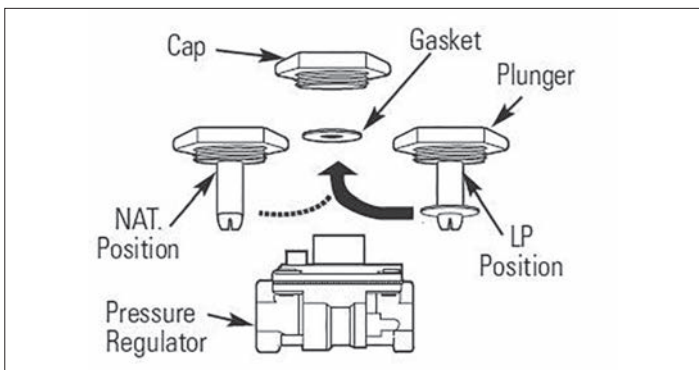

Never connect an unregulated gas line to the oven.



WARNING

Do not change the regulator/hose assembly or use any other assembly than the one supplied with your Lynx oven.

Do not attempt to use a 5LP-A equipped regulator/hose assembly with a standard 510 POL cylinder/valve assembly.

Do not store a spare LP-gas cylinder under or near this appliance.

Never fill the cylinder beyond 80 percent full.

If the information above is not followed exactly, a fire causing death or serious injury may occur.

LP Cylinder Requirements

The LP cylinder must be constructed and marked in accordance with the specifications for LP gas cylinders of the U.S. Department of Transportation (DOT) and designed for use with a Type 1 system only.

Cylinders of free standing ovens must be secured using the provided cylinder retention system to avoid accidental movement.

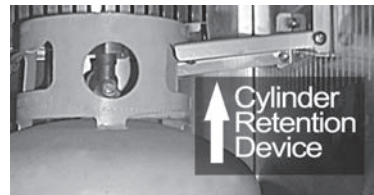

When exchanging your cylinder for a refill, exchange only for a Type 1 20lb cylinder with an over-fill protection device.

Never use a cylinder with a damaged valve.

A dented or rusty LP cylinder may be hazardous and should be avoided. If in doubt, have it checked by your LP supplier.

Always check for leaks after every LP cylinder change. (See INDEX: "Leak Test" for further details.)

Always shut off the LP-gas supply at the cylinder when the oven is not in use.

Cylinders must be stored outdoors in a well-ventilated area out of the reach of children. If your oven is stored indoors, the LP cylinder must be stored outside.

GAS CONNECTIONS ...*continued*

LP Connections

Make sure the LP cylinder valve is fully closed. It is possible for the valve to be open without releasing gas but, as soon as you start connecting the regulator, gas will leak from the connection.

Insert the regulator inlet into the cylinder valve and turn the black coupler clockwise until the coupler is hand tight. Do not over-tighten this connection.

To disconnect the coupler, first make sure the main cylinder valve is turned off. Grasp the coupler and turn counter clockwise. The inlet will then disengage.

Always leak-test the connection after refilling or exchanging LP cylinders. (See INDEX: "Leak Test" for further details.)

GAS LINE PURGING

You should purge the gas line of air before attempting to light the oven.

- Make sure all oven controls are in the "OFF" position.
- Slowly turn on the main gas supply.
- Turn on the gas valve and confirm that the igniter is glowing. It is furthest from the fuel source and will completely purge the lines. It will take several seconds for the burner to light.
- The igniter will stay ON and light the burner when the air has been removed from the line.
- Wait at least 5 minutes after shutting off the control before attempting to light the burners.

GAS CONVERSION KITS

Gas conversion kits are available from Lynx Grills to allow the oven to operate on either Natural gas or LPG. These kits should be installed by a qualified technician.

The kits come with complete installation instructions. These instructions should be read completely and fully understood before installing the conversion kit.

ELECTRICAL CONNECTIONS



WARNING: ELECTRICAL GROUNDING

- Product installation must meet local electric codes or, in the absence of local codes, the latest edition of the National Electrical Code ANSI/NFPA No. 70 or the Canadian Electrical Code CGA 1.6b2005.
- Use only a Ground Fault Interrupter (GFI) protected circuit with this outdoor cooking gas appliance.
- Do not use this outdoor cooking appliance if it has been submerged under water without thorough inspection by a qualified technician.
- This oven is equipped with a three prong (grounding) electric plug for your protection against shock hazard and must be plugged directly into a properly grounded three prong outlet. Never cut or remove the grounding prong from this plug.
- Use only extension cords with a 3 prong grounding plug, rated for the power of the equipment, and approved for outdoor use with a "W-A" marking.
- To protect against electric shock, do not immerse any part of the power cord, an extension cord or any plugs in water or other liquid.
- Unplug the product from the outlet when not in use and before cleaning. Allow it to cool before putting on or taking off parts.
- Do not let the cord hang over the edge of a table or touch hot surfaces.
- Do not use an outdoor cooking gas appliance for purposes other than intended.
- Do not operate any outdoor cooking gas appliance with a damaged cord, plug, or after the appliance malfunctions or has been damaged in any manner. Contact the manufacturer for repair.

CONNECTION TO AC

Installation requires an outdoor 120VAC 15A GFI (Ground Fault Interrupter) electrical outlet adjacent to the oven.

The GFI outlet features an internal breaker that reduces shock hazard. This type of outlet should be installed by a qualified electrician either inside the island enclosure for built-in units, or near the location where a free-standing unit will be used.

The oven wiring harness is designed to facilitate connections to other Lynx accessories such as the side burners.

When installing the transformer to the oven be careful to prevent the wiring and transformer from contacting any hot surfaces behind or below the oven. It is recommended that the transformer be located below the oven in a readily accessible location. Be sure to provide adequate access to facilitate service if the transformer or connections should need future maintenance.

If the electrical system fails to operate, a connection may have come loose in shipping or the GFI may have tripped, requiring a reset. See the Troubleshooting section for more details.

FINAL CHECKS

LEAK TESTING



DANGER!

To prevent fire or explosion hazard, DO NOT smoke or allow any potential source of ignition (sparks, electrical arcing, etc) in the area while performing a leak test. Leak tests should be conducted outdoors only. Never conduct a leak test using fire or flame.

Leak Test Procedure:

- Create a soapy solution of 1 part soap and 3 parts water.
- Confirm that all control knobs are in the off position.
- Turn on the fuel supply. For natural gas, turn the valve handle 1/4 turn to align with the gas flow.
- For L.P., turn the cylinder valve knob counter clockwise one full rotation.
- Apply the soap solution generously by paint brush or squirt bottle on all connections and fittings.
- If bubbles appear to “grow” on any of the connections, you have a gas leak. IMMEDIATELY turn off the gas supply.

Fixing a Gas Leak:

- Shut off the gas supply
- Turn all oven controls to the “ON” position to purge the oven of any gas build-up, then turn the controls back “OFF”.
- Wash off the soapy solution with cold water and dry.
- Tighten the loose joint, or replace the faulty part with manufacturer-recommended replacement parts.
- DO NOT attempt to repair the L.P. cylinder valve if it is damaged. The only way to safely resolve a damaged cylinder is to REPLACE IT.
- Repeat the leak test to ensure that no leaks are present.

NOTE: The burners do not have an air shutter.

- The appearance of the burners should be visually checked. The ceramic tiles should be uniformly red to orange in appearance. Burners flames should be 4-5 inches tall and predominately blue in color with some yellow tipping. There should be no lifting, fluttering or lazy blue flames. Some food particles will show as yellow flames but should burn off.

ONE LAST THING

Finally, before leaving, check all the burners for proper operation. Make sure the control knobs turn freely and completely through their full range.

IMPORTANT:

Make sure the owner knows where the main gas supply shut off valve is located.

Finally, for safety and for proper use & care, you must leave this manual with the owner. Make sure you advise them to keep it for future reference.

For technical assistance call:

Lynx Customer Care
888-289-5969

WIRING SCHEMATICS

LPZA & LPZAF

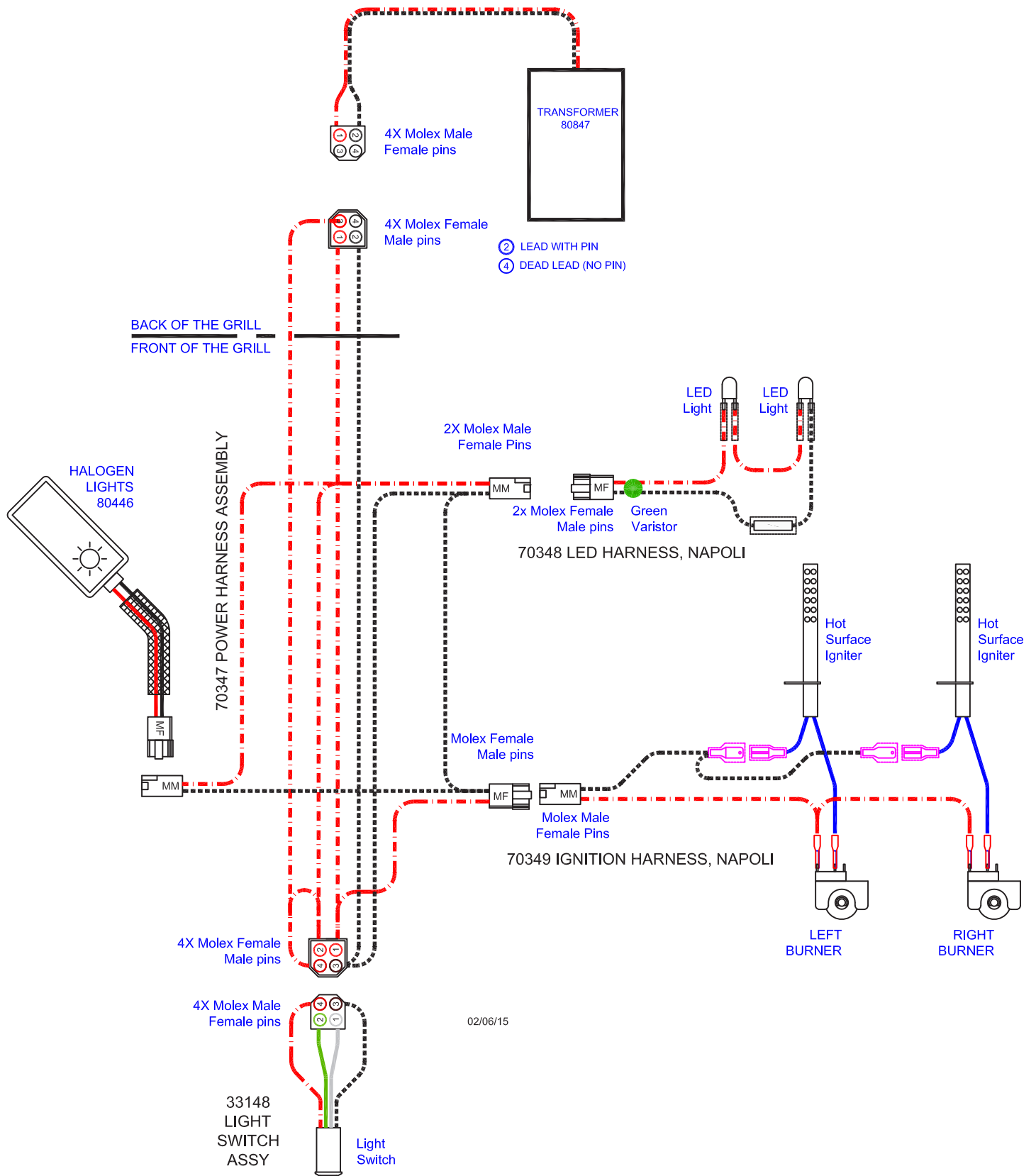

LYNX PROFESSIONAL NAPOLI PIZZA OVEN EXPLODED PARTS VIEW

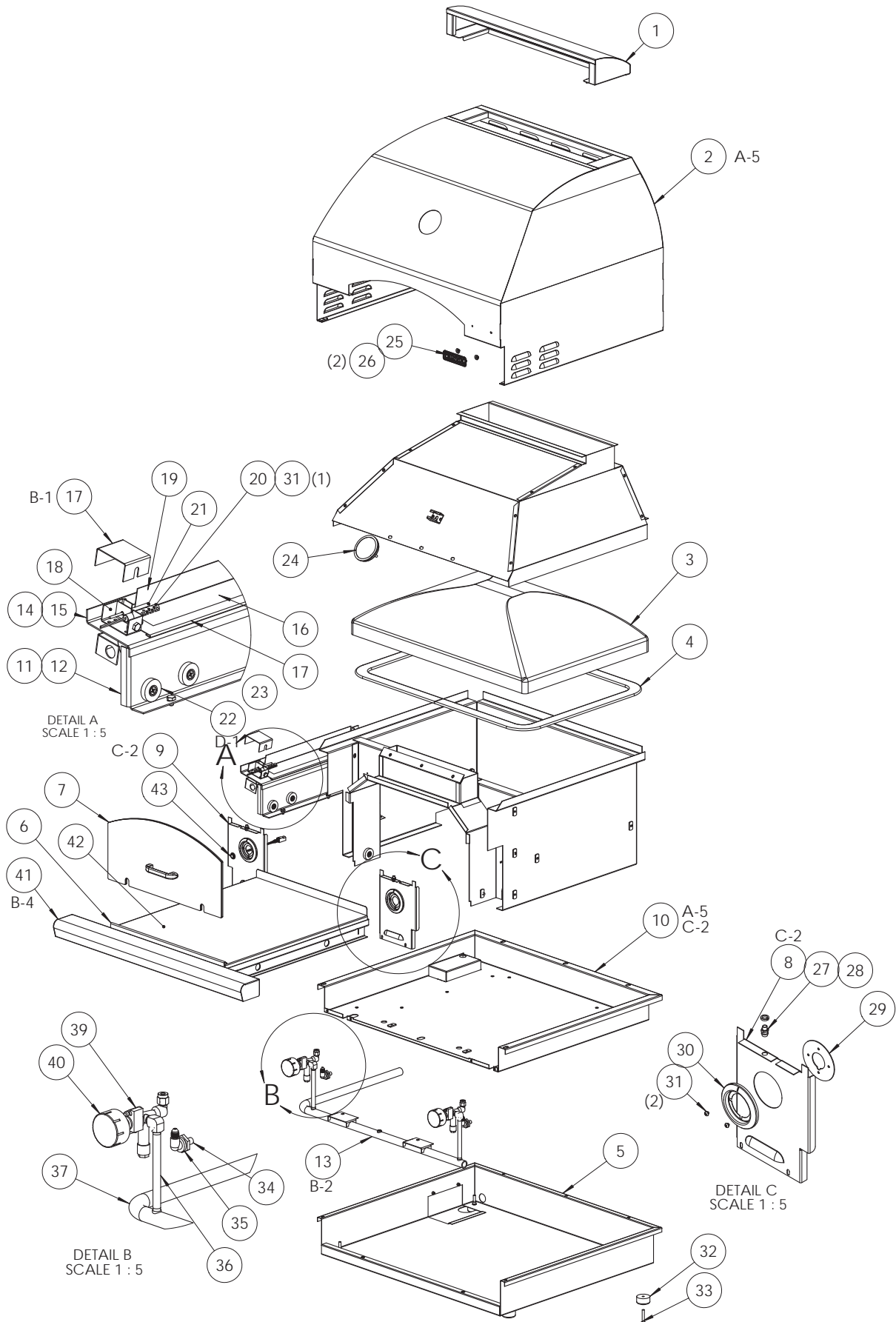

LYNX PROFESSIONAL NAPOLI PIZZA OVEN PARTS LIST

ITEM	PART No.	DESCRIPTION	QTY.
1	70323	COVER, HOOD WELDMENT	1
2	70319	HOOD WELDMENT	1
3	35117	DOME, LPZA	1
4	35316	GASKET, FIBERGLASS	1
5	80943	FLOOR SUPPORT ASSEMBLY	1
6	80938	PULLOUT TRAY ASSY.	1
7	80939	ACCESS DOOR ASSY.	1
8	35175	CONTROL PANEL, RH	1
9	35176	CONTROL PANEL, LH	1
10	70336	BASE PAN WELDMENT	1
11	70343	SUPPORT, WHEEL ASSY. RH	1
12	70344	SUPPORT, WHEEL ASSY. LH	1
13	80937	GAS TRAIN ASSEMBLY	1
14	70338	SUPPORT, BURNER RH	1
15	70339	SUPPORT, BURNER LH	1
16	32988	BURNER, IR 16" - 27"	2
17	35313	IR IGNITER COVER, NAPOLI	2
18	80791	IR BRACKET ASSEMBLY- RH	1
19	35122	BURNER TRIM	2
20	20018	THERMOCOUPLE, IR	2
21	33052	IGNITER, HOT SURFACE (SHORT)	2
22	10192	BEARING, FLT SS 1.3125 DIA	8
23	10193	SPACER, 1/4 NOM, 1/2 O.D. X .21, SS, RND	8
24	33558	THERMOMETER, WATERTIGHT	1
25	L11074	LYNX LOGO	1
26	31062	NUT, 1/8, SPEED, STEEL, SELF THREADING	2
27	32554	LED HOUSING	2
28	32055	WASHER, 5/16, SPL, SS	2
29	35318	BEZEL PLATE	2
30	10001	BEZEL	2
31	31929	SCREW, #6-32 X 1/8", PHP, SS	4
32	34374	RUBBER BUMPER, 0.75" HT	4
33	32202	SCREW, 1/4-20 x 3/4	4
34	31880	ORIFICE NG #43	2
	13020	ORIFICE LP #54	2
35	31795	BRASS 90 DEGREE ELBOW 7/16-20	2
36	35179	VALVE NIPPLE	2
37	70322	MANIFOLD ASSEMBLY	1
38	35222	FLEX TUBE, 1/4" X 7" LG , SS	2
39	34970	VALVE, SAFETY ADJUSTABLE, BODY	2
40	35190	KNOB	2
41	35169	BULLNOSE, 30" HANDLE	1
42	35118	TILE, LPZA	1
43	33148	LIGHT SWITCH ASSEMBLY	1
FASTENERS			
A	30290	SCREW, 1/4-20 X 1/2, TRUSS HEAD PHILLIPS	-
B	31930	SCREW, 1/4-20 X 3/8, HEX HEAD	-
C	14014	SCREW, #8-32 X 1/2, TRUSS HEAD PHILLIPS	-
D	14043	SCREW, 1/4-20 X 1 FLAT HEAD PHILLIPS	-
ELECTRICAL (NOT SHOWN - REFERENCE 70346)			
	80847	TRANSFORMER ASSEMBLY	1
	80446	HALOGEN LIGHT ASSEMBLY	1
(43)	33148	LIGHT SWITCH	1
	70347	POWER HARNESS ASSEMBLY	1
	70348	LED HARNESS ASSEMBLY	1
	70349	IGNITION HARNESS ASSEMBLY	1

MODEL-SPECIFIC BTU OUTPUTS & MAX. RUNS FOR APPLIANCES

MODEL-SPECIFIC BTU OUTPUTS		
MODEL	INFRARED BURNER (Btu)	TOTAL INPUT
LPZA	2 @ 20,000	40,000 Btu/Hr

MAXIMUM RUNS FOR ALL APPLIANCES ON SUPPLY LINE	
Run Length 3/4" Pipe (in feet)	Max BTU for all Appliances on line
10	360,000
20	245,000
30	198,000
40	169,000
50	150,000
60	135,000
70	123,000
80	115,000

NOTE: IF A 1/2 INCH LINE IS USED WITH NATURAL GAS IT SHOULD BE NO LONGER THAN 12 FEET.

INDEX

#	
4/11 Regulator	27
B	
Baking in Windy Conditions	9
Before Each Use	10
Before You Start	22
BTU Outputs, Model Specific	34
C	
Checklist Before Each Use	3
Cleaning Your LYNX Oven	14
Clearance to Combustibles	24
Contacting LYNX	18
Conversion Kits.....	28
Cut-out Dimensions, Built-in Pizza Oven.....	25
D	
Damage:	
Concealed	22
Visible	22
E	
Electrical Connections	29
Exploded Parts View	32
F	
Final Checks	30
G	
Gas Connections	26
Gas Line Purging	28
Gas Requirements	26
Gas Supply Line Runs	34
I	
Important Safety Precautions	8
L	
Leak Test Procedure	30
Lighting, Manual	13
Lighting Your Oven	3, 13
LP Cylinder Requirements	27
LP Gas	27
M	
Manual Lighting	13
Maximum Runs for all appliances on supply line.....	34
Message to Our Customers.....	5
N	
Natural Gas	26
O	
Obtaining Service from LYNX.....	18
P	
Parts List	33
Parts View, Exploded	32
Pre-Bake Checklist	10
Pre-Heating the Oven	10
Purging the Gas Line	28
R	
Regulator Conversion	27
S	
Schematic, LPZA & LPZAF.....	31
Service, contacting LYNX	18
T	
Technical Support	18
Troubleshooting	15
U	
Unpacking and Assembly	23
Using Your Oven.....	10
W	
Warranty:	
Warranty, Limited.....	19
Warranty, Common Area Limited	20
Windy Conditions, Baking in	9

Lynx Grills, Inc.
7300 Flores St.
Downey, CA 90242
Service: (888) Buy-Lynx (888-289-5969)
Fax: (562) 299-6978
www.lynxgrills.com

