

This Owner's Manual is provided and hosted by [Appliance Factory Parts](#).



Napoleon HMF200 Owner's Manual

[Shop genuine replacement parts for Napoleon HMF200](#)



[Find Your Napoleon HVAC Parts - Select From 105 Models](#)

----- Manual continues below -----

INSTALLER: LEAVE THIS MANUAL WITH THE APPLIANCE.
CONSUMER: SAVE THESE INSTRUCTIONS



INSTALLATION AND OPERATING INSTRUCTIONS

EN

CERTIFIED UNDER CANADIAN AND AMERICAN NATIONAL STANDARDS: UL 391 5th Ed 2010, UL 727 9th Ed 2006, CSA B366.1-M91, CSA B140.4-04, CSA B212-00, CSA B415.1-10.

RPT# 415-S-09b-2, 415-S-09c-8.3

FR
PG
91

HYBRID 150/200 HMF150/200 MULTI-FUEL FURNACES

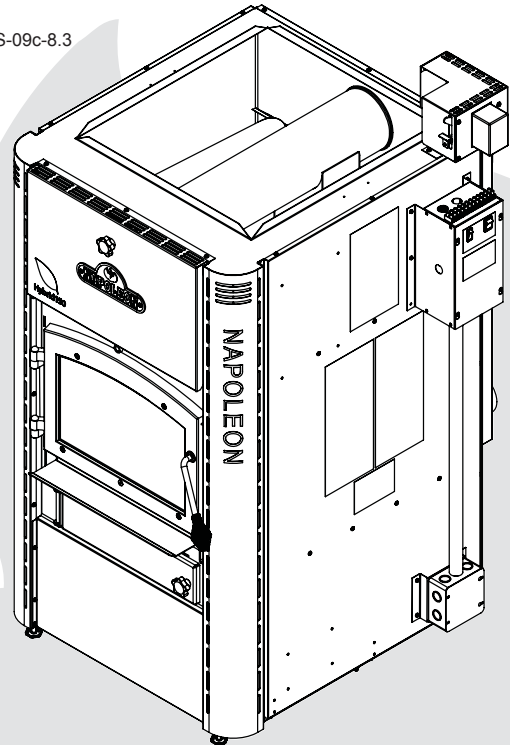

SAFETY INFORMATION

WARNING

If the information in these instructions are not followed exactly, a fire or explosion may result causing property damage, personal injury or death. Please read entire manual before you install and use your heater.

- This heater can be very hot when burning.
- Combustible materials such as firewood, wet clothing, etc. placed too close can catch fire.
- Children and pets must be kept from touching the heater when it is hot.
- The chimney must be sound and free of cracks. Before installing this unit, contact the local building or fire or other authority having jurisdiction and follow their guidelines.
- Operate only with the doors tightly closed.
- Do not use an elevated grate or otherwise raise the fire.
- This heater is designed to burn natural wood only. Higher efficiencies and lower emissions generally result when burning air dried seasoned hardwoods, as compared to softwoods or to green or freshly cut hardwoods.
- Do not start a fire with chemicals or fluids such as gasoline, engine oil, etc.
- Do not burn treated wood, coal, charcoal, coloured paper, cardboard, solvents or garbage.
- Do not let the heater become hot enough for any part to glow red.

WARNING



**HOT GLASS WILL
CAUSE BURNS.**
**DO NOT TOUCH GLASS
UNTIL COOLED.**
**NEVER ALLOW CHILDREN
TO TOUCH GLASS.**



Quality System Certified To
ISO
9001-2008

APPLY SERIAL NUMBER LABEL FROM CARTON



Serial No. X X X X X 0 0 0 0 0 0
MODEL NO.

Wolf Steel Ltd., 24 Napoleon Rd., Barrie, ON, L4M 0G8 Canada /
103 Miller Drive, Crittenden, Kentucky, USA, 41030

Phone (705)721-1212 • Fax (705)722-6031 • www.napoleonheatingandcooling.com • hvac@napoleonproducts.com

H1.20B

TABLE OF CONTENTS

1.0	INSTALLATION OVERVIEW	3
2.0	INTRODUCTION	4
2.1	DIMENSIONS	5
2.2	GENERAL INSTRUCTIONS	5
2.3	GENERAL INFORMATION	7
2.3.1	FEATURES	7
2.3.2	HEATING SPECIFICATIONS	7
2.3.3	ELECTRICAL SPECIFICATIONS	7
2.3.4	OPTIONAL MODULES	7
2.3.5	APPLICABLE STANDARDS	7
2.3.6	CALIFORNIA PROP65	7
2.4	RATING PLATE INFORMATION	7
3.0	INSTALLATION PLANNING	8
3.1	LOCATION AND CLEARANCES	8
3.2	OUTSIDE COMBUSTION AIR	8
4.0	UNCRATING AND ASSEMBLY	10
4.1	CRATED UNIT CONTAINS	10
4.2	RECOMMENDED STEP	10
4.3	REMOVAL OF FURNACE FROM BASE OF SKID	11
4.4	CONFIGURING HMF150/200 AS LEFT OR RIGHT "RETURN AIR" (RA)	12
4.5	MOUNT MAIN ELECTRICAL HARNESS TO FURNACE	12
4.6	MOUNTING PRIMARY AIR CONTROL	13
4.7	SECONDARY AIR TUBES	14
4.8	DOOR HANDLE INSTALLATION	16
5.0	CONFIGURATION OF LEFT AND RIGHT RETURN AIR WITH OTHER HYBRID MODULES	17
5.1	HYBRID HMF150/200 AS A "ADD ON" TO EXISTING FURNACE	18
5.2	HYBRID HMF150/200 AS A "STAND ALONE" WOOD FURNACE	23
5.3	HYBRID HMF150/200 AS A COMBINATION "WOOD/OIL" FURNACE	25
5.4	HYBRID HMF150/200 AS A COMBINATION "WOOD/ELECTRIC" FURNACE	33
5.5	HYBRID HMF150/200 AS A "WOOD/OIL/ELECTRIC" FURNACE	36
6.0	PLENUM AND VENTING INSTALLATION/CLEARANCE TO COMBUSTIBLE MATERIALS	37
6.1	FLUE / CHIMNEY FOR HMF150/200 IN CONFIGURATIONS:	37
6.1.1	CONTROLLING DRAFT	37
6.2	VENTING CONFIGURATION FOR WOOD/OIL COMBINATION FURNACE	38
6.3	GENERAL PLENUM AND DUCTING - MINIMUM CLEARANCE TO COMBUSTIBLES	40
6.3.1	HMF150 SHIELDING SPECIFICATIONS	40
6.3.2	HMF200 SHIELDING SPECIFICATIONS	41
6.4	FLUE CONFIGURATION FOR "ADD ON" FURNACE CONFIGURATION	42
6.4.1	CONTROLLING DRAFT	42
6.4.2	MEASURING DRAFT	43
6.5	CONNECTING DUCTWORK/PLENUMS BETWEEN "ADD ON" FURNACE AND ORIGINAL FURNACE	43
6.6	EMBER STOP	44
6.7	CONNECTING A HMF FURNACE SYSTEM TO AIR CONDITIONING	45
6.7.1	SEASONAL DAMPER POSITIONS	46
6.7.2	DIMENSIONAL CONSIDERATIONS FOR BYPASS DUCT	47
6.7.3	INTERLOCKING DAMPER POSITIONS TO THE PRIMARY AIR CONTROL OF THE WOOD FURNACE	47
7.0	ELECTRICAL CONNECTIONS AND SCHEMATICS	49
7.1	LOW VOLTAGE WIRING - THERMOSTAT	49
7.2	THERMOSTAT LOCATION	49
7.3	BLOWER BOX WIRING CONNECTIONS	49
7.3.1	SELECTING AIR CONDITIONING BLOWER SPEEDS	50
7.4	ELECTRIC SCHEMATICS - GENERAL HARNESS LAYOUT	52
7.4.1	GENERAL HARNESS LAYOUT: ALL CONFIGURATIONS	52
7.4.2	GENERAL HARNESS LAYOUT: WOOD/"ADD ON" CONFIGURATION INCLUDING NAPOLEON WOOD/GAS COMBO	53
7.4.3	GENERAL HARNESS LAYOUT: WOOD CONFIGURATION	54
7.4.4	GENERAL HARNESS LAYOUT: WOOD/OIL CONFIGURATION	55
7.4.5	GENERAL HARNESS LAYOUT: WOOD/ELECTRIC CONFIGURATION	56
7.4.6	GENERAL HARNESS LAYOUT: WOOD/OIL/ELECTRIC CONFIGURATION	57
7.5	ELECTRIC SCHEMATICS - CONTROL WIRING WITHOUT AIR CONDITIONING	58
7.5.1	CONTROL WIRING WITHOUT AIR CONDITIONING: ALL CONFIGURATIONS	58
7.5.2	CONTROL WIRING WITHOUT AIR CONDITIONING: "ADD ON" FURNACE CONFIGURATION INCLUDING NAPOLEON WOOD/GAS COMBO	59
7.5.3	CONTROL WIRING WITHOUT AIR CONDITIONING: WOOD FURNACE ONLY CONFIGURATION	60
7.5.4	CONTROL WIRING WITHOUT AIR CONDITIONING: OIL FURNACE CONFIGURATION	61
7.5.5	CONTROL WIRING WITHOUT AIR CONDITIONING: ELECTRIC FURNACE CONFIGURATION	62
7.5.6	CONTROL WIRING WITHOUT AIR CONDITIONING: OIL/ELECTRIC FURNACE CONFIGURATION	63
7.6	ELECTRIC SCHEMATICS - CONTROL WIRING <u>WITH</u> AIR CONDITIONING	64
7.6.1	CONTROL WIRING <u>WITH</u> AIR CONDITIONING: "ADD ON" FURNACE CONFIGURATION INCLUDING NAPOLEON WOOD/GAS COMBO	64
7.6.2	CONTROL WIRING <u>WITH</u> AIR CONDITIONING: WOOD FURNACE ONLY CONFIGURATION	65
7.6.3	CONTROL WIRING <u>WITH</u> AIR CONDITIONING: WOOD/OIL FURNACE CONFIGURATION	66
7.6.4	CONTROL WIRING <u>WITH</u> AIR CONDITIONING: WOOD/ELECTRIC FURNACE CONFIGURATION	67
7.6.5	CONTROL WIRING <u>WITH</u> AIR CONDITIONING: WOOD/OIL/ELECTRIC FURNACE CONFIGURATION	68
7.7	ELECTRIC SCHEMATICS - MAIN CONTROL HARNESS	69
8.0	GENERAL OPERATING INSTRUCTIONS	71
8.1	OPERATION FOR HIGHER EFFICIENCY AND LOWER EMISSIONS	71
8.2	SMOKE AND CARBON MONOXIDE EMISSIONS AND MONITORS	71
8.3	CONTROL SYSTEM - WOOD FURNACE	72
8.3.1	POWER OUTAGE OPERATION	73
8.4	CONTROL SYSTEM - SECONDARY FURNACE "ADD ON", "WOOD/OIL", "WOOD/ELECTRIC", "WOOD/OIL/ELECTRIC" CONFIGURATIONS	73
8.5	CONTROL SYSTEM - SUMMER FAN/CONTINUOUS FAN/HRV'S	74
8.6	OPERATING SOUNDS AND SMELLS	74

8.7	STARTING A FIRE	75
8.8	DRAFT CONTROL	76
8.9	FUEL LOADING AND BURN CYCLE	77
8.10	RE-LOADING THE APPLIANCE	78
8.11	FLASH FIRES	78
8.12	SMOKING	78
8.13	ASH REMOVAL PROCEDURES	79
8.14	INSPECTION OF HEAT EXCHANGERS, FLUES AND CHIMNEYS	79
9.0	MAINTENANCE	80
9.1	RUN-AWAY OR CHIMNEY FIRE	80
9.2	FIRE EXTINGUISHERS AND SMOKE DETECTORS	80
9.3	GLASS AND GASKET REPLACEMENT	80
9.4	FIREBRICKS AND BAFFLES	81
9.5	SELECTING WOOD	81
9.6	GLASS REPLACEMENT	82
9.7	INSULATION INSERT REPLACEMENT	83
9.8	CREOSOTE FORMATION AND REMOVAL	83
9.8.1	MAINTENANCE OF THE EXCHANGERS	84
9.8.2	CHIMNEY MAINTENANCE	84
9.9	FILTERS	85
9.10	BLOWER MOTOR LUBRICATION	85
9.11	DOOR GASKET MAINTENANCE	85
9.12	CARE OF GLASS (IF EQUIPPED)	85
10.0	REPLACEMENTS	86
11.0	TROUBLE SHOOTING GUIDE	87
12.0	WARRANTY	88
13.0	SERVICE HISTORY	89
14.0	NOTES	90

NOTE: Changes, other than editorial, are denoted by a vertical line in the margin.

1.0 INSTALLATION OVERVIEW

! WARNING

THIS APPLIANCE AND ITS COMPONENTS ARE DESIGNED TO BE INSTALLED AND OPERATED AS A SYSTEM. ANY ALTERATION TO OR SUBSTITUTION FOR ITEMS IN THIS SYSTEM, UNLESS ALLOWED BY THESE INSTALLATION INSTRUCTIONS, WILL VOID THE OMNI LISTING AND MAY VOID THE WARRANTY. IT MAY ALSO CREATE A HAZARDOUS INSTALLATION. READ THROUGH THESE INSTRUCTIONS THOROUGHLY BEFORE STARTING YOUR INSTALLATION AND FOLLOW THEM CAREFULLY THROUGHOUT YOUR PROJECT.

H68.1

INSTALLATION OVERVIEW

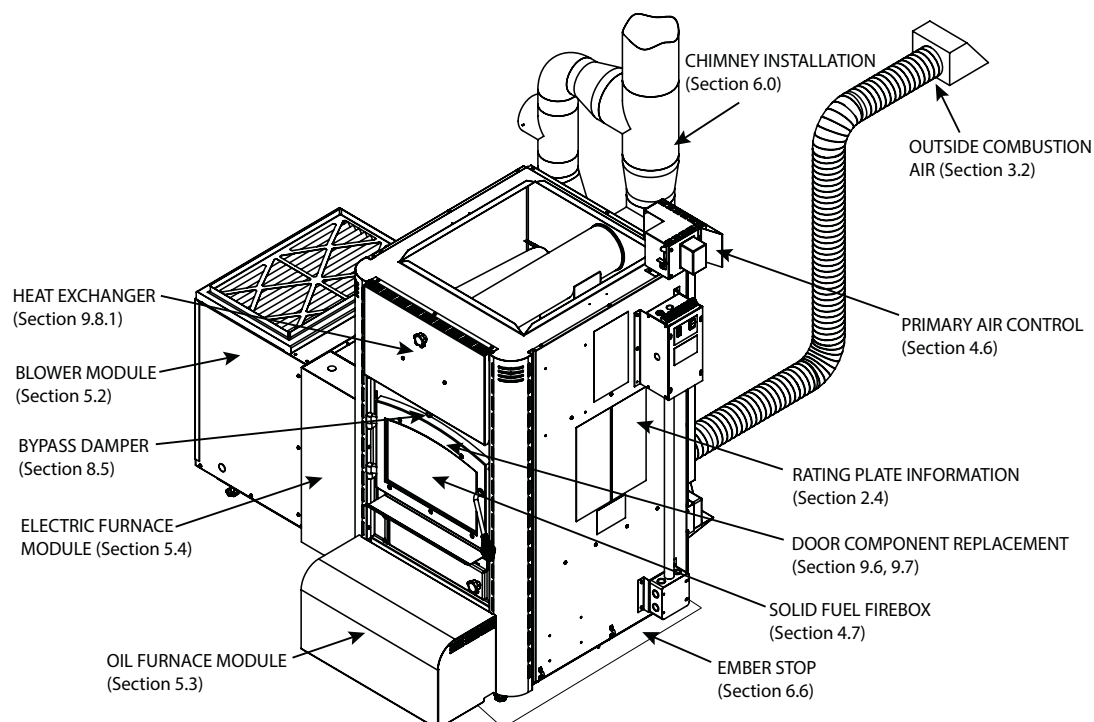

2.0 INTRODUCTION

 **WARNING**

- **THIS APPLIANCE IS HOT WHEN OPERATED AND CAN CAUSE SEVERE BURNS IF CONTACTED.**
- Do not operate appliance before reading and understanding operating instructions. Failure to operate appliance according to operating instructions could cause fire or injury.
- Risk of burns. The appliance should be turned off and cooled before servicing.
- Do not operate without fully assembling all components.
- Do not install damaged, incomplete or substitute components.
- Risk of cuts and abrasions. Wear protective gloves and safety glasses during installation. Sheet metal edges may be sharp.
- Young children should be carefully supervised when they are in the same room as the appliance. Toddlers, young children and others may be susceptible to accidental contact burns. A physical barrier is recommended if there are at risk individuals in the house. To restrict access to an appliance or stove, install an adjustable safety gate to keep toddlers, young children and other at risk individuals out of the room and away from hot surfaces.
- Clothing or other flammable material should not be placed on or near the appliance.
- Due to high temperatures, the appliance should be located out of traffic and away from furniture and draperies.
- Ensure you have incorporated adequate safety measure to protect infants/toddlers from touching hot surfaces.
- Even after the appliance is out, the glass and/or screen will remain hot for an extended period of time.
- Check with your local hearth specialty dealer for safety screens and hearth guards to protect children from hot surfaces. These screens and guards must be fastened to the floor.
- Any safety screen or guard removed for servicing must be replaced prior to operating the appliance.
- It is imperative that the control compartments, burners and circulating blower and its passageway in the appliance and venting system are kept clean. The appliance and its venting system should be inspected before use and at least annually by a qualified service person. More frequent cleaning may be required due to excessive lint from carpeting, bedding material, etc. The appliance area must be kept clear and free from combustible materials, gasoline and other flammable vapors and liquids.
- Under no circumstances should this appliance be modified.
- Do not use this appliance if any part has been under water. Immediately call a qualified service technician to inspect the appliance and to replace any part of the control system and any gas control which has been under water.
- Do not operate the appliance with the glass door removed, cracked or broken. Replacement of the glass should be done by a licensed or qualified service person.
- Do not strike or slam shut the appliance glass door.
- Only doors / optional fronts certified with the unit are to be installed on the appliance.
- Keep the packaging material out of reach of children and dispose of the material in a safe manner. As with all plastic bags, these are not toys and should be kept away from children and infants.
- If the appliance is not properly installed, a house fire may result. Do not expose the appliance to the elements (ex. rain, etc.) and keep the appliance dry at all times. Wet insulation will produce an odour when the appliance is used.
- The chimney must be sound and free of cracks. Clean your chimney a minimum of twice a year and as required.
- The appliance is designed to burn natural wood only. Do not burn treated wood, coal, charcoal, coloured paper, cardboard, solvents or garbage. This appliance has not been tested with an unvented gas log set. To reduce risk of fire or injury, do not install an unvented gas log set into the appliance.
- Do not start a fire with chemicals or fluids such as gasoline, engine oil, etc.
- Operate only with the doors tightly closed.
- Do not let the appliance become hot enough for any part to glow red.
- Higher efficiencies and lower emissions generally result when burning air dried seasoned hardwoods, as compared to softwoods or too green or freshly cut hardwoods. Burning wet unseasoned wood can cause excessive creosote accumulation. When ignited it can cause a chimney fire that may result in a serious house fire.
- Do not use elevated grate or otherwise raise the fire.
- Do not store the wood within appliance installation clearances or within the space required for re-fueling and ash removal.
- Your appliance requires periodic maintenance and cleaning. Failure to maintain your appliance may lead to smoke spillage in your home.

2.1 DIMENSIONS

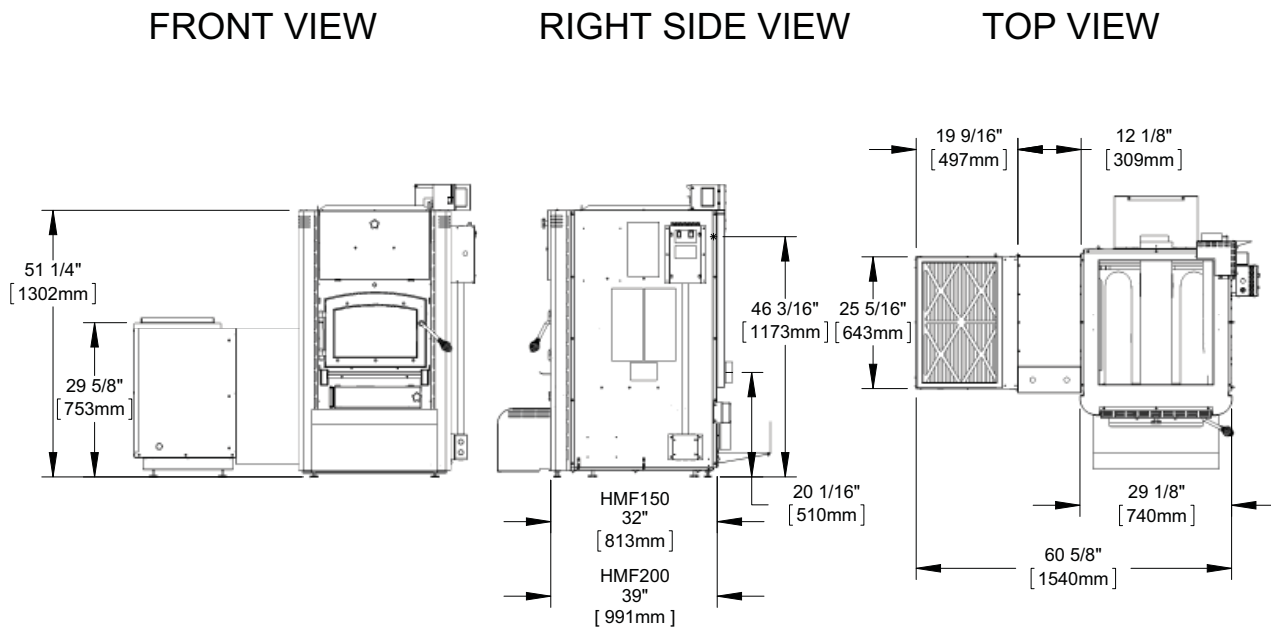

2.2 GENERAL INSTRUCTIONS

! WARNING
BEFORE INSTALLING THIS APPLIANCE, CONTACT THE LOCAL BUILDING OR FIRE OR OTHER AUTHORITY HAVING JURISDICTION AND FOLLOW THEIR GUIDELINES.
THIS APPLIANCE MUST BE INSTALLED BY A QUALIFIED INSTALLER. FOLLOW THE INSTALLATION DIRECTIONS. DO NOT OPERATE WITHOUT FULLY ASSEMBLING ALL COMPONENTS.
IF THIS APPLIANCE IS NOT PROPERLY INSTALLED, A HOUSE FIRE MAY RESULT.
DO NOT EXPOSE THE APPLIANCE TO THE ELEMENTS (EX. RAIN, ETC.) AND KEEP THE APPLIANCE DRY AT ALL TIMES. WET INSULATION WILL PRODUCE AN ODOUR WHEN THE APPLIANCE IS USED.
THIS APPLIANCE IS HOT WHEN OPERATED AND CAN CAUSE SEVERE BURNS IF CONTACTED. CHILDREN AND PETS MUST BE KEPT FROM TOUCHING THE APPLIANCE WHEN IT IS HOT. CONTACT YOUR LOCAL AUTHORIZED DEALER / DISTRIBUTOR FOR SAFETY SCREENS THAT MAY BE AVAILABLE FOR THIS PRODUCT.
COMBUSTIBLE MATERIAL SUCH AS FIREWOOD, WET CLOTHING, ETC. PLACED TOO CLOSE CAN CATCH FIRE. OBJECTS PLACED IN FRONT OF THE APPLIANCE MUST BE KEPT A MINIMUM OF 48" (1219MM) FROM THE FRONT OF THE APPLIANCE.
ALL WIRING SHOULD BE DONE BY A QUALIFIED ELECTRICIAN AND SHALL BE IN COMPLIANCE WITH LOCAL CODES AND WITH THE NATIONAL ELECTRIC CODE ANSI/NF NO. 70-CURRENT (IN THE UNITED STATES), OR WITH THE CURRENT CSA C22.1 CANADIAN ELECTRIC CODE (IN CANADA).

H68.2

AIR FLOW
CIRCULATION AND
HEAT TRANSFER

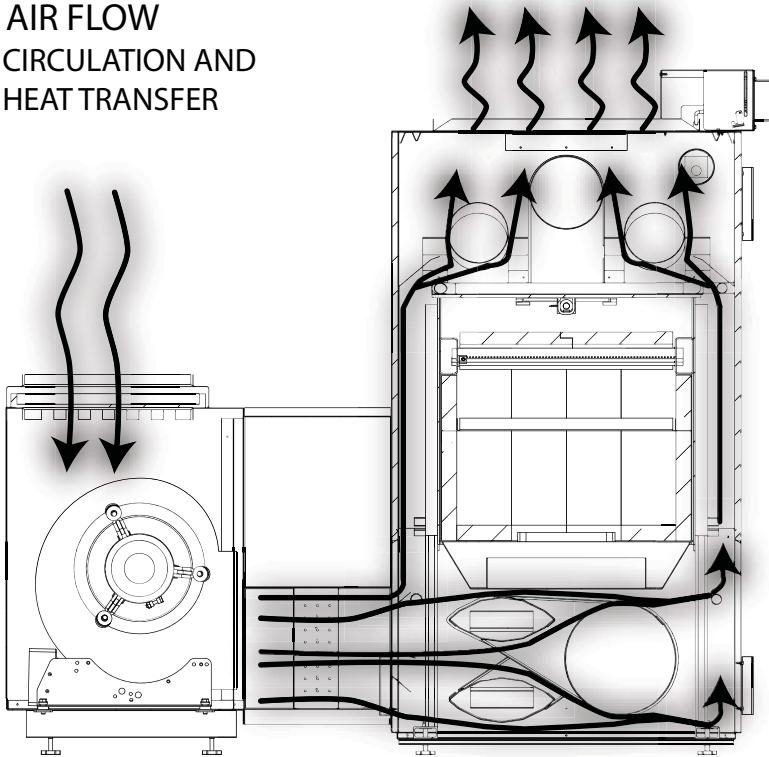

COMBUSTION AIR FLOW

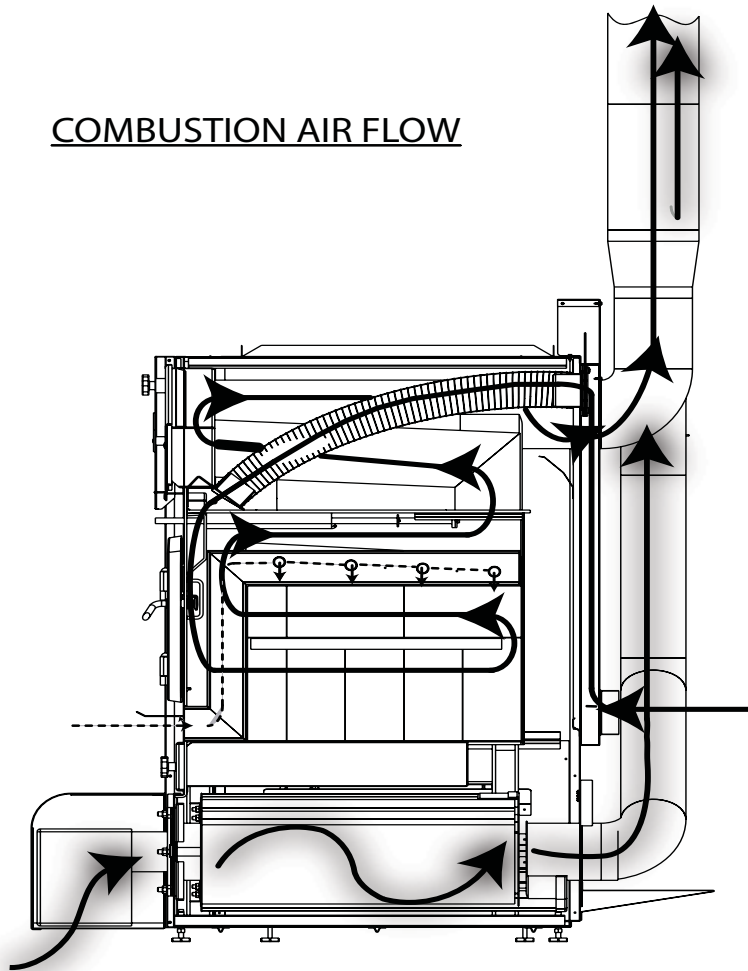

2.3 GENERAL INFORMATION

2.3.1 FEATURES

- Maximum log length of 24" (610mm) (HMF150), and 30" (762mm) (HMF200)
- Long burn time - up to 12 hours (HMF150), 18 hours (HMF200)
- Automatic control with thermostat
- Large firebox capacity
- Outside air for combustion
- Choice of glass door for radiant heat through front of furnace, or solid door to provide more heating through exchange surfaces
- Firebrick lining for firebox creates kiln like temperatures for maximum efficiency and low emissions

2.3.2 HEATING SPECIFICATIONS



H3.31

IMPORTANT

Differences in chimney height and draft may lower overall burn times.

Approximate Heating Capacity up to 2,000 square feet (167.23m²) for HMF150 and 3,000 square feet (278.71m²) for HMF200 (Will vary with the home's floor plan, insulation and outside temperature).

Maximum burn time up to 12 hours (HMF150), 18 hours (HMF200).

Average BTU Output per hour 70,000 - 85,000 (HMF150), 95,000 - 110,000 (HMF200).

Oil furnace module up to 91,000 BTU input.

Electric furnace up to 20 Kw (HMF150), 25 Kw (HMF200).

2.3.3 ELECTRICAL SPECIFICATIONS

Fully configured furnace 13.3 amps, 120 V, when Riello oil burner is used in multi furnace configuration.

Fully configured furnace 17.4 amps, 120 V, when Beckett oil burner is used in multifurnace configuration.

(Optional electric furnace module's up to 85 amps.)

2.3.4 OPTIONAL MODULES

Optional Modules Available:

- Glass Door HMFK-GLASS, Solid Door HMFK-SOLID
- "Add On" Furnace Module HMFK-ADDON
- Blower Box Module HMFK-BMP50-1
- HMF/Gas Transition Module HMFK-GT
- Electric Furnace Module HMFK-EF15, -EF18, -EF20 (HMF150), HMFK-EF18, -EF20, -EF25 (HMF200)
- Oil Furnace Module HMFK-CMBCH-1 (HMF150), HMFK-CCH200 (HMF200), HMFK-OFRF40, HMFK-OFBNX, HMFK-WMO
- Bi Energy Module (Quebec) HMFK-BIEK

2.3.5 APPLICABLE STANDARDS

Certification Standards and Installation Codes:

UL391	CSA B415.1-10	CAN/CSA-C22.2 NO.0-M91
UL727	CSA B365-10	CAN/CSA-C22.2 NO.3-M1986
CSA B366.1-M91	CSA B139-09	ANSI/NF NO.70
CSA B140.4-04	NFPA 211	
CSA B212-00	CSA 22.1	

2.3.6 CALIFORNIA PROP65

Use of this product may produce smoke which contains chemicals known to the State of California to cause cancer, birth defects, or other reproductive harm.

2.4 RATING PLATE INFORMATION

Rating plate is located on furnace side panel without the return air opening.

3.0 INSTALLATION PLANNING

 WARNING
WEAR GLOVES AND SAFETY GLASSES FOR PROTECTION.
KEEP HAND TOOLS IN GOOD CONDITION, SHARPEN CUTTING EDGES AND MAKE SURE TOOL HANDLES ARE SECURE.
DO NOT MAKESHIFT COMPROMISES DURING INSTALLATION. DO NOT BLOCK OR RESTRICT AIR. DO NOT IMPEDE AIR MOVEMENT ZONES MARKED "CLEARANCE TO COMBUSTIBLES".

H3.32

3.1 LOCATION AND CLEARANCES

 WARNING
FOR C/HMF150 DO NOT INSTALL INTO ANY AREA HAVING A HEIGHT LESS THAN 6 FEET 3 INCHES (1.9M) (CAN BE REDUCED TO 6 FEET (1.8M) WHEN SHIELDING SPECIFICATIONS ARE MET). SEE SECTION 6.3.
FOR C/ HMF200 DO NOT INSTALL INTO ANY AREA HAVING A HEIGHT LESS THAN 7 FEET (2.13M) (CAN BE REDUCED TO 6 FEET 9 INCHES (2.06M) WHEN SHIELDING SPECIFICATIONS ARE MET) SEE SECTION 6.3.
THIS APPLIANCE, CONFIGURED WITH ALL MODULES, WEIGHS: C/HMF150 - 700LBS (318KG), C/ HMF200 - 830LBS (375KG). ENSURE THERE IS ADEQUATE FLOOR SUPPORT FOR THE APPLIANCE.
THE VERTICAL HEIGHT OF THE AIR INTAKE LINER MUST NOT BE GREATER THAN 2/3 THE HEIGHT OF THE CHIMNEY.

H3.33A

For detailed clearance to combustibles, see Section 6.0 for plenum and consideration of venting location.

3.2 OUTSIDE COMBUSTION AIR

 WARNING
DO NOT DRAW OUTSIDE AIR FROM GARAGE SPACES. EXHAUST PRODUCTS OF GASOLINE COMBUSTION ENGINES ARE HAZARDOUS.
DO NOT DRAW OUTSIDE AIR FROM ATTIC SPACES, BASEMENTS OR ABOVE THE ROOFING WHERE OTHER HEATING APPLIANCES OR FANS AND CHIMNEYS EXHAUST OR UTILIZE AIR. THESE PRECAUTIONS WILL REDUCE THE POSSIBILITY OF APPLIANCE SMOKING OR AIR FLOW REVERSAL.
THE OUTSIDE AIR INLET MUST REMAIN CLEAR OF LEAVES, DEBRIS ICE AND/OR SNOW. IT MUST BE UNRESTRICTED WHILE APPLIANCE IS IN USE TO PREVENT COMBUSTION AIR STARVATION WHICH CAN CAUSE SMOKE SPILLAGE AND AN INABILITY TO MAINTAIN A FIRE. SMOKE SPILLAGE CAN ALSO SET OFF SMOKE ALARMS.
NEGATIVE PRESSURE WITHIN YOUR HOME MAY INADVERTENTLY AFFECT YOUR APPLIANCE. EXHAUST FANS SUCH AS BATHROOM FANS, RANGE HOODS AND CLOTHES DRYERS CAN STRONGLY INFLUENCE NEGATIVE PRESSURE IN THE HOUSE.
AIR INLET TERMINALS MUST BE INSTALLED WITH ADEQUATE GROUND CLEARANCE AND BE SUFFICIENTLY SHIELDED FROM PREVAILING WINDS TO PREVENT FROM REVERSING IN THE VENT SYSTEM.

H3.34

The Napoleon HMF150/200 may take outside combustion air directly into the appliance through a 4" (102mm) inlet collar at the back of the unit. This inlet is to supply combustion air for the HMF150/200 Wood Furnace only.

Secure and seal the intake liners to the collars using 3 sheet metal screws, and high temperature sealant.

Insulating the intake liners is recommended in colder climates to prevent condensation from occurring. The 4" (102mm) inlet can also draw combustion air from the room provided adequate make up air is available. Fresh air makeup for the oil furnaces must follow criteria set in installation standard CSA B139-09 "Installation Code For Oil Burning Equipment", and installed by a certified oil mechanic. Fresh air makeup for gas fired furnaces must follow criteria set in installation standard CAN/CGA-B149.1 or CAN/CGA-B149.2. Fresh air makeup solid fuel furnaces must follow criteria set in installation standard CAN/CSA-B365.

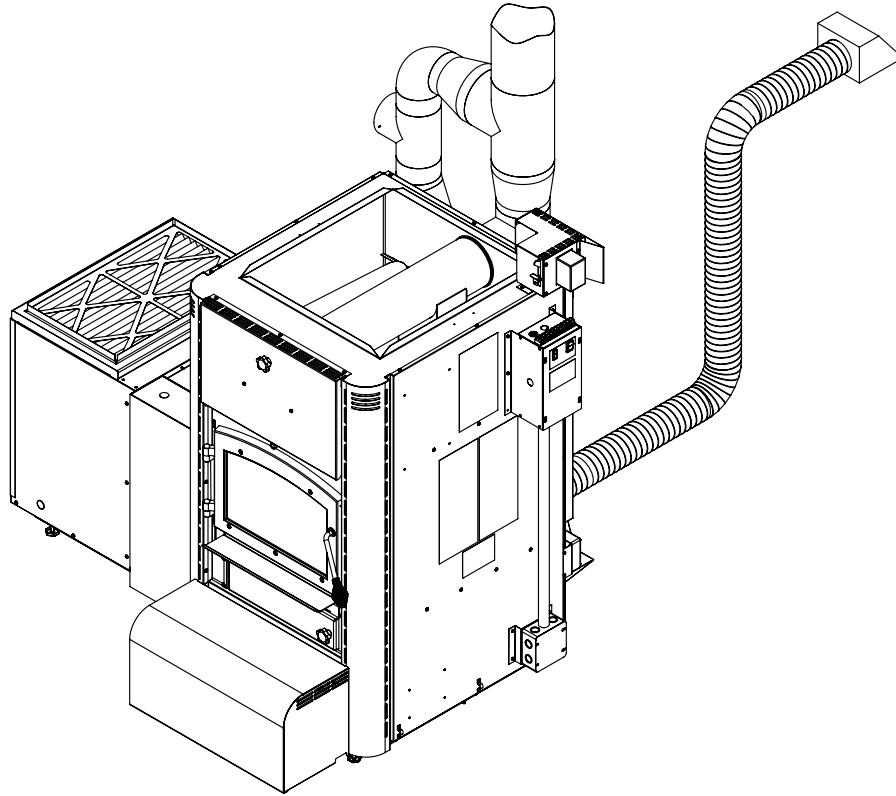

⚠ WARNING

WHEN INSTALLING A SYSTEM FOR MAKE UP FRESH AIR, THE INSTALLER MUST TAKE INTO ACCOUNT A SATISFACTORY AIR MAKE UP RATE IN THE LIKELIHOOD THAT MORE THAN ONE FUEL-BURNING FURNACE IN A MULTI FURNACE CONFIGURATION MAY OPERATE AT THE SAME TIME.

The vertical height of the air intake liner must not be greater than 2/3 the height of the chimney.

The duct terminations must be located so they can not be blocked (i.e. snowdrifts). 4' (1.22m) above grade or above maximum snow grade for the area is recommended. Make a 4 1/2" inch (114 mm) hole to suit in an outside wall of the house. From outside, place the fresh air hood into the hole, open side down. Seal with caulking and secure.

VERTICAL RISE BETWEEN	HORIZONTAL RUN
6' & 10' (1.83m & 3.05m) MAX	5' (1.52m)
3' & 6' (0.91m & 1.83m)	15' (4.57m)
1' & 3' (0.31m & 0.91m)	20' (6.10m)
0' & 1' (0m & 0.31m)	25' (7.62m)

H12.10.1

H3.35

AIR INTAKE LINERS

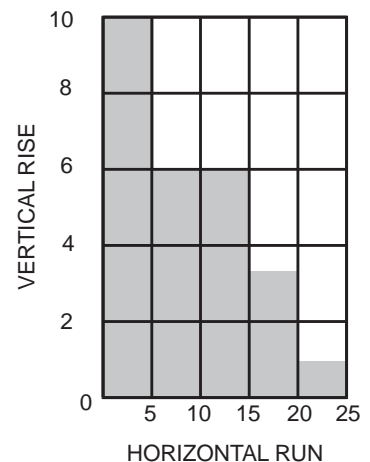

H12.2.1

4.0 UNCRATING AND ASSEMBLY

4.1 CRATED UNIT CONTAINS

- Primary Air Control Kit
- Main / Electrical Harness Kit (1 pc.)
- Bricks (37 pcs. HMF150, 53 pcs. HMF200)
- Baffles (2 pcs.)
- Secondary Air Tubes (4 pcs. HMF150, 5 pcs. HMF200)
- Installation and Operating Manual
- Limit Switch and Mount Bracket (Plenum) (2 pcs.)
- Stand Offs and Hardware

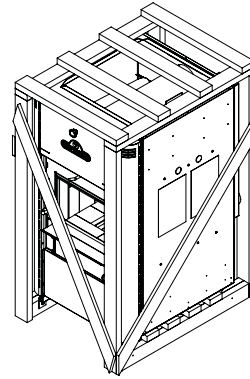

4.2 RECOMMENDED STEP

CAUTION

MANOUEVRING AND PALLET REMOVAL REQUIRES A MINIMUM OF TWO PEOPLE.

CAUTION

HIGH CENTRE OF GRAVITY! THIS UNIT IS VERY TOP HEAVY! USE CAUTION WHEN MANOUEVRING OR REMOVING THE FURNACE FROM THE BASE PALLET.

! WARNING

THE BASE PALLET IS SECURED TO THE FURNACE BY ADJUSTING THE LEGS AT THE BOTTOM OF THE FURNACE.

THE BASE PALLET SHOULD NOT BE REMOVED UNTIL THE FURNACE IS PLACED CLOSE TO ITS FINAL INSTALLATION LOCATION!

LIFTING OF THE FURNACE SHOULD BE THROUGH THE BASE PALLET - LIFTING OF FURNACE BY METAL BASE HOUSING CAN RESULT IN DAMAGE

H3.36

If the crating is too large for maneuvering in the doorways and staircases, remove the crate verticals, diagonals and top pallet.

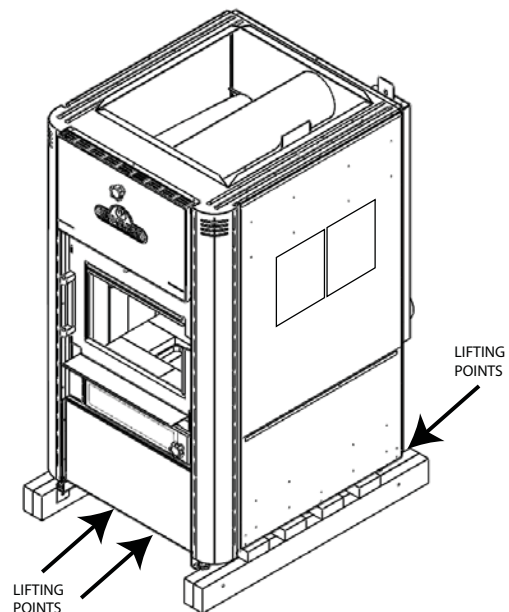
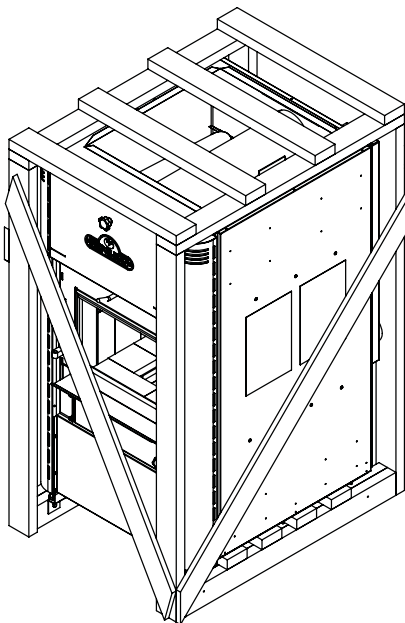

4.3 REMOVAL OF FURNACE FROM BASE OF SKID

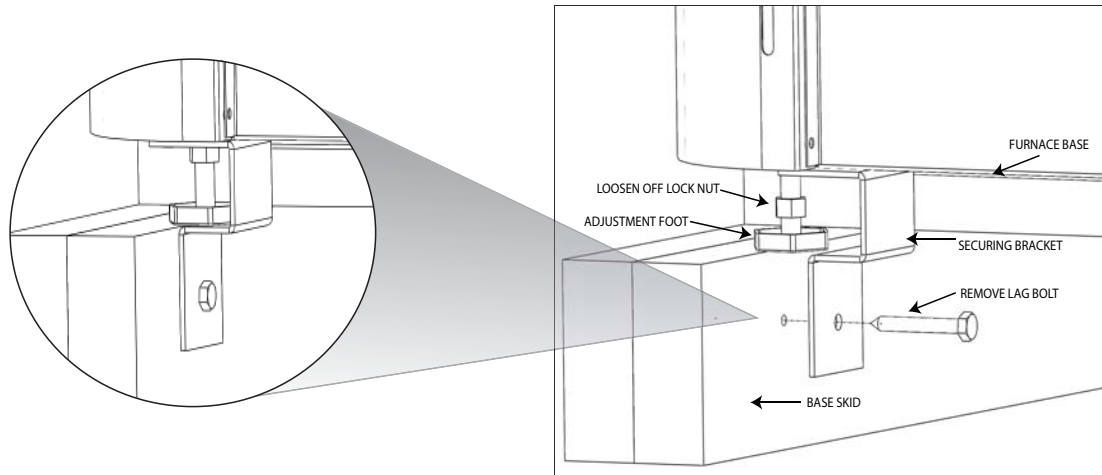

CAUTION
 HIGH CENTRE OF GRAVITY! USE EXTREME CAUTION TO AVOID TOPPLING OF THE FURNACE
 "CRUSH HAZARD"!

STEP #1:

Push the furnace to one side until close to the weight tipping the skid.

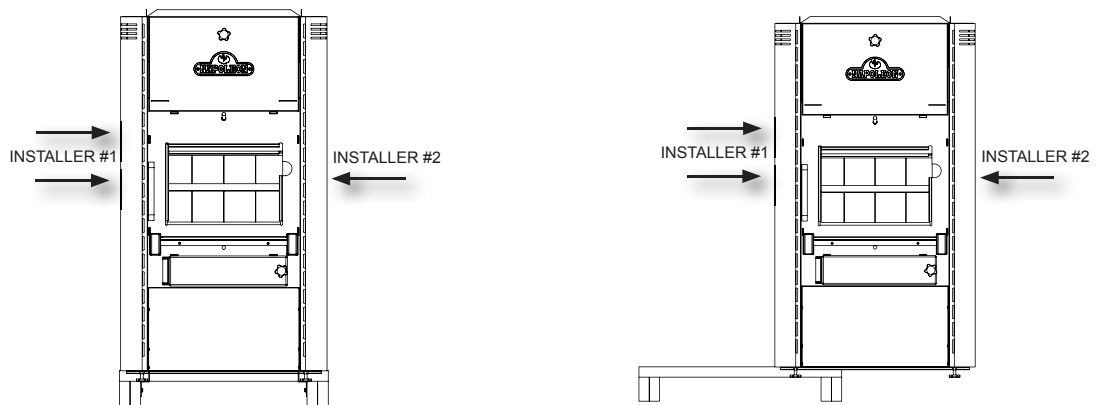

STEP #2:

Firmly support side of the furnace (near top) to prevent furnace toppling, when the skid/furnace are tilted.

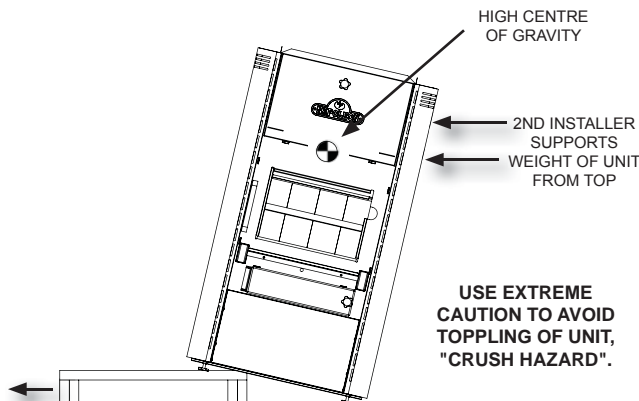

STEP #3:

Pull the skid from under the unit, and gently tilt the furnace upright onto the levelling feet.

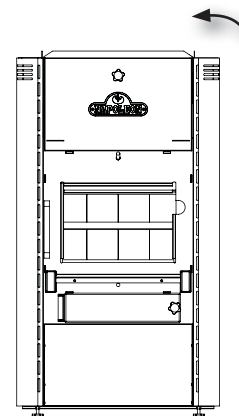

4.4 CONFIGURING HMF150/200 AS LEFT OR RIGHT "RETURN AIR" (RA)

The HMF150/200 can be installed upstream with the return air, (also supply air from pre existing furnace "add on" configuration), entering from the left or right hand sides of the furnace. The HMF150/200 comes configured for left side RA.

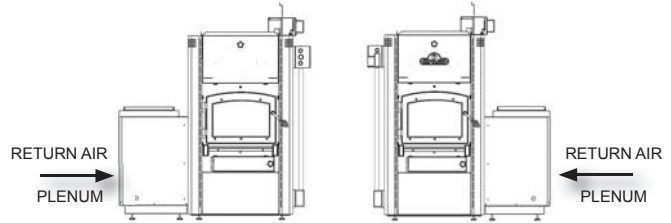

LEFT AND RIGHT HAND SIDE PANELS ARE REVERSIBLE

STEP #1:

Remove all screws holding side panels.

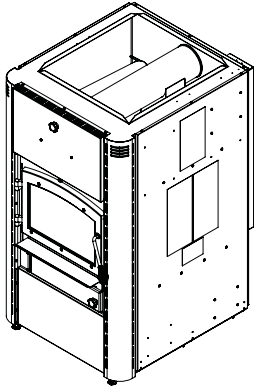

STEP #2:

Tilt side panels outwards from top and pull up diagonally.

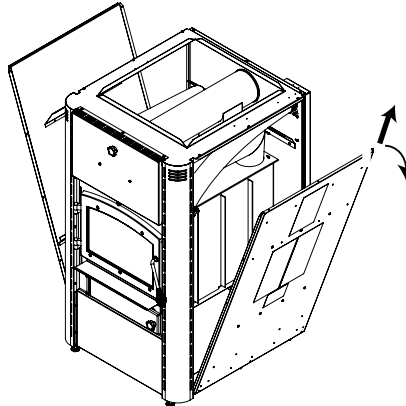

STEP #3:

Switch panels to opposite sides and reverse process.

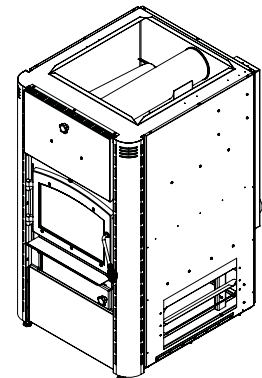

4.5 MOUNT MAIN ELECTRICAL HARNESS TO FURNACE

LEFT RA

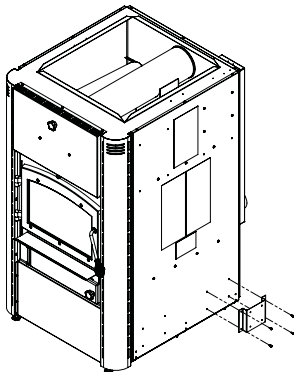

Attach the electrical mounting bracket with fasteners supplied.

Line up the bracket mounting holes with the dimple in the furnace side panel.

Note that in both left and right RA configurations the mounting bracket goes closest to the rear of the furnace.

RIGHT RA

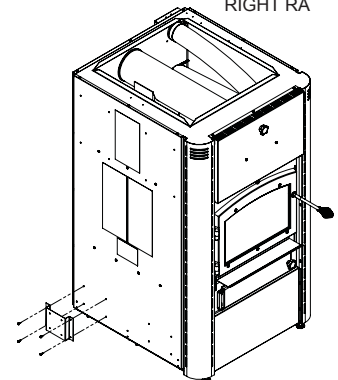

LEFT RA

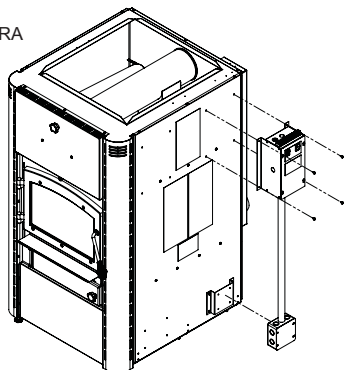

Secure the electric harness upper portion to the furnace side panel, and the lower portion to the installed bracket.

RIGHT RA

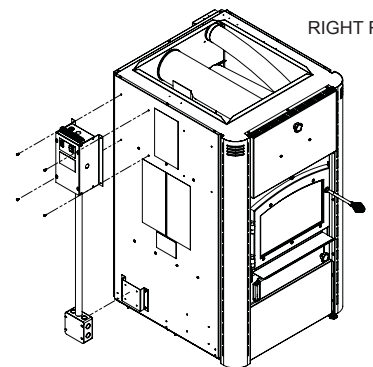

4.6 MOUNTING PRIMARY AIR CONTROL

IMPORTANT:

This step must follow the plenum installation in Section 6.0. The plenum is not shown in diagrams below, for clarity purposes.

Location of the Primary Air Control in left and right RA.

LEFT HAND RA

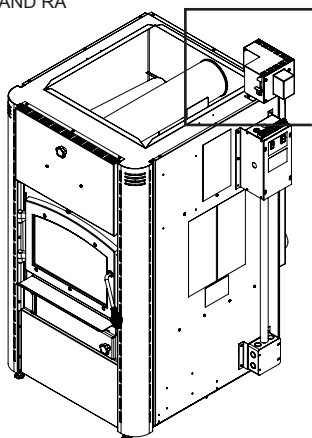

RIGHT HAND RA

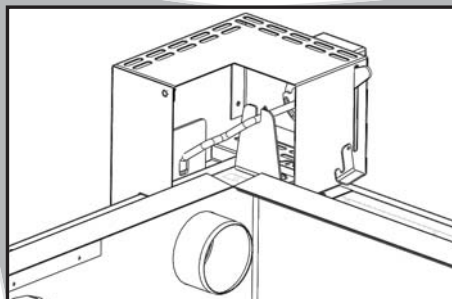
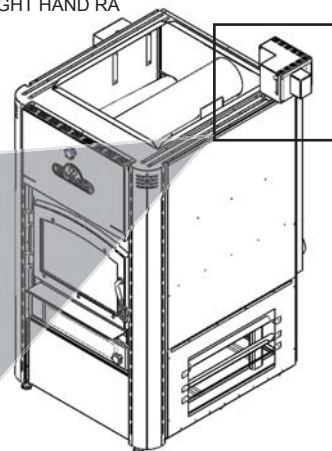

1. Attach Vertical Guide Bracket (VGB) to the Top of the rear air supply chamber.
 - a. Centre the VGB around the control rod opening as per diagram and position the two vertical fingers of the VGB so the bend in these fingers are flush with the back side of the shutter plate.
 - b. Locate VGB on screws inserted in the predrilled holes of the rear air supply chamber, as per diagrams. **DO NOT TIGHTEN SCREWS SO BRACKET CAN BE ADJUSTED.**
 - c. With shutter plate pushed towards the front of the furnace in the air damper assembly slot, and the base of the VGB held firmly down on the top of the air supply chamber, position the bend in the vertical fingers so there is a 0" to 1/32" gap between the back of the shutter plate and the bend in the vertical fingers.

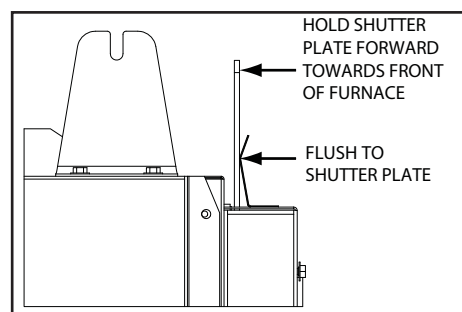
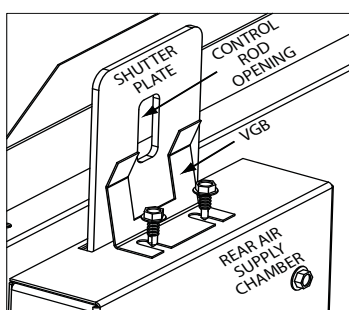

! WARNING

THE FINGERS MUST NOT EXERT ANY FORWARD FORCE ON THE SHUTTER PLATE WITH THE MOUNTING SCREWS TIGHTENED. THE SHUTTER PLATE MUST SLIDE UP AND DOWN FREELY IN THE SLOT, AND SHOULD READILY FALL (GRAVITY ONLY) INTO THE SLOT IF RAISED BY HAND 2" (51mm) AND RELEASED. IF ANY TENSION EXISTS BETWEEN VGB AND SHUTTER PLATE, THE FRICTION MAY PREVENT THE SHUTTER PLATE FROM FALLING, CAUSING THE FURNACE TO OVER FIRE.

H3.37

2. Assemble the control box as illustrated using the fasteners supplied.

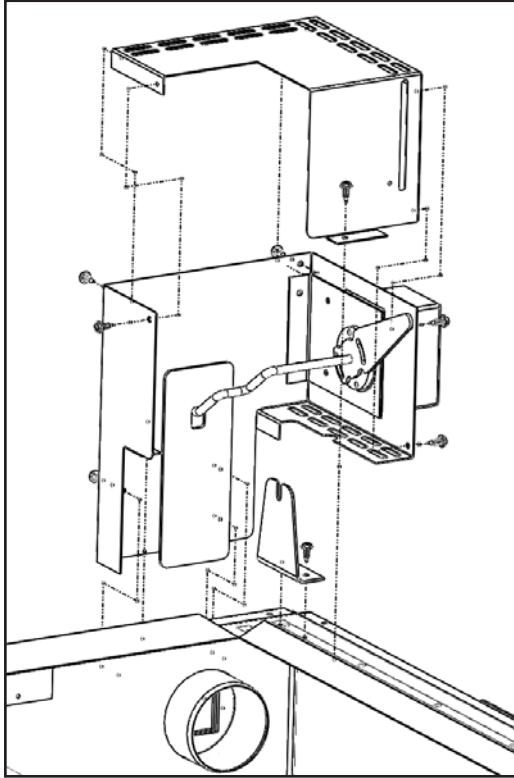

Main air control box is secured with (3) screws into the rear panel and (1) through the inside flange of the main box and into the furnace top.

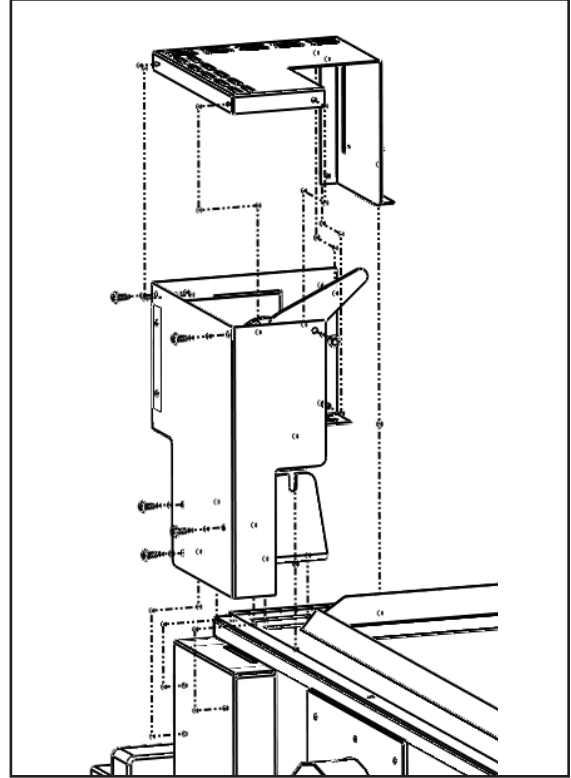

3. Check manual override operation of the shutter plate by sliding the primary damper lever up and down at the front of the Top Damper Bracket. Again the shutter shall move up and down freely and the shutter should readily return to the closed position under gravity.
4. Connect electrical control circuit and ensure shutter moves freely (open and close) when the wood thermostat cycles on and off for heat demand.

4.7 SECONDARY AIR TUBES

The rear most secondary air tubes have been factory installed. The remaining three secondary air tubes in conjunction with the compressed vermiculite baffles will need to be installed as follows:

NOTE

The front 3 secondary tubes on the HMF200 have larger holes than the rear 2.

STEP #1

- Insert the next tube in the rear most hole in the left side manifold, as illustrated in "A".
- Slide the tube towards the right side of firebox, into the opposite hole, as illustrated in "B".

NOTE

The keyway in the secondary tube must align with the keyed part of the acceptance hole in the right hand side secondary manifold.

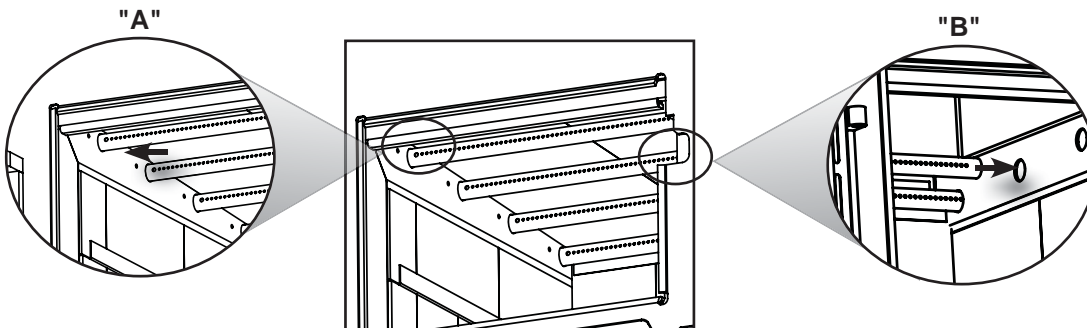

NOTE

The holes in the tubes must face to front of furnace.

STEP #2

- Once the secondary tube has been pushed completely to the right and the key has engaged the keyway, insert a hitch pin into the left most clearance hole of the secondary tube.

**STEP #3**

- Carefully pivot the compressed vermiculite baffles up onto the rear secondary air tubes as illustrated. Ensure that the top baffles are pushed all the way to the rear of the firebox overlapping the rear bricks, leaving a minimum 2.75" (70mm) (HMF150) / 4.75" (121mm) (HMF200) gap along the front. This will allow the flue gases to escape the firebox. Spread the baffles tight to each side to ensure there are not gaps, as illustrated.

HMF150 SIDE VIEW

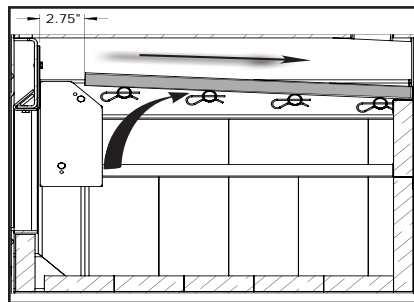

HMF200 SIDE VIEW

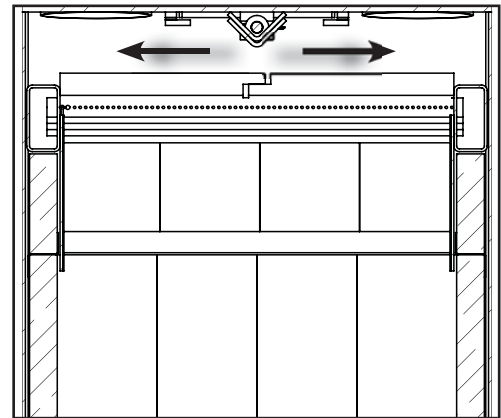
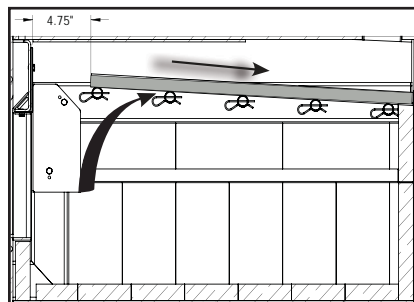

FRONT VIEW

STEP #4

- Repeat steps 1 thru 3 with remaining tubes until all are installed.

4.8 DOOR HANDLE INSTALLATION

EN

! WARNING

BURNING YOUR APPLIANCE WITH THE DOORS OPEN OR AJAR CREATES A FIRE HAZARD THAT MAY RESULT IN A HOUSE AND OR CHIMNEY FIRE.

DO NOT STRIKE OR SLAM DOOR.

NEVER REMOVE THE DOOR WHEN THE APPLIANCE IS HOT.

H3.1

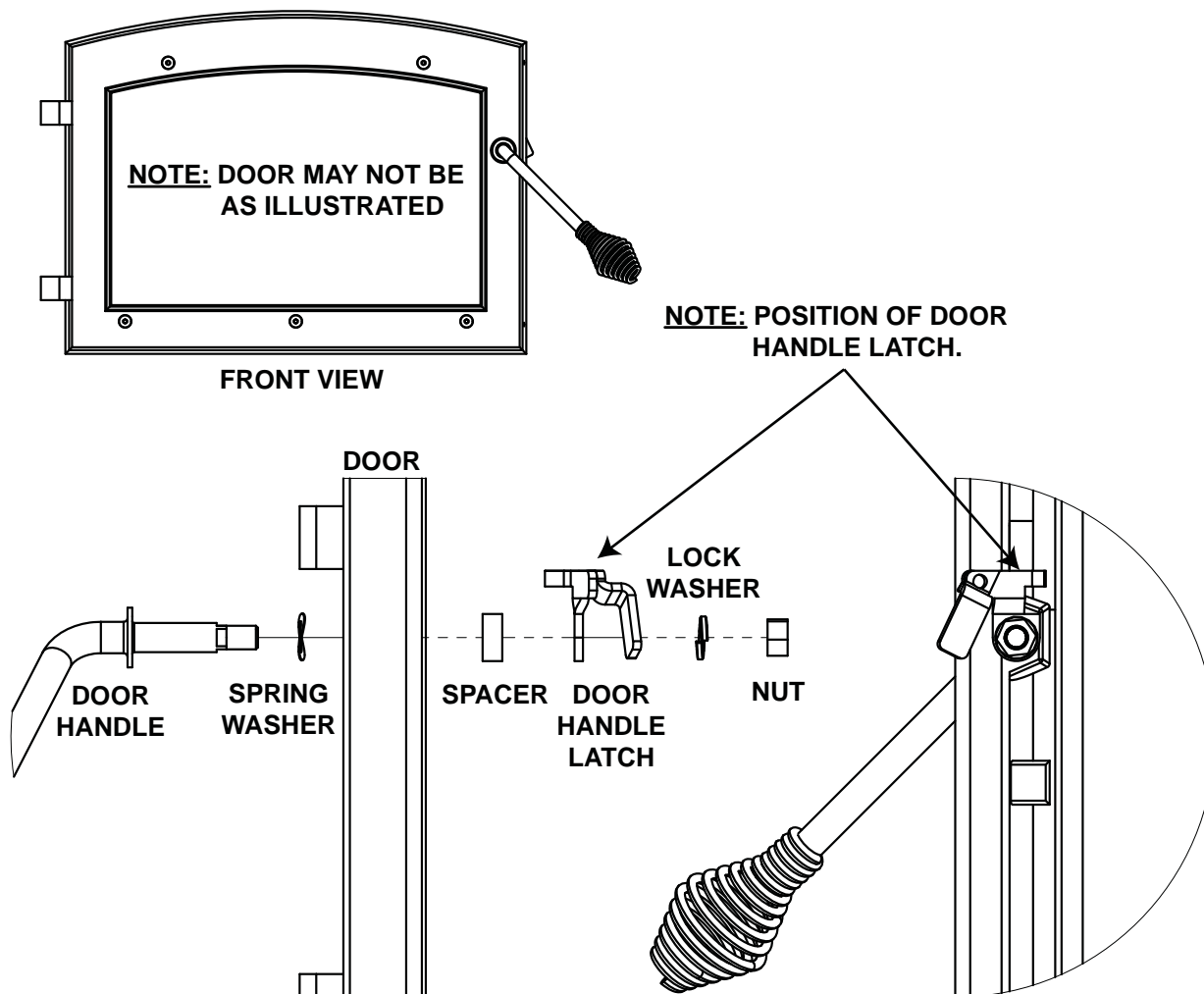

H98.2

5.0 CONFIGURATION OF LEFT AND RIGHT RETURN AIR WITH OTHER HYBRID MODULES

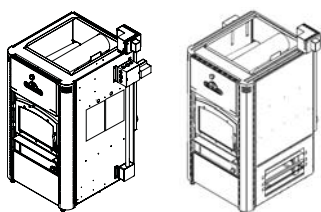

Hybrid HMF150/200 as a "Add On" to existing furnace (see Section 5.1). In this application the HMFK-BMP50 blower module is not used.

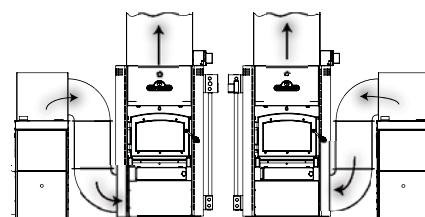

Hybrid HMF150/200 as a Stand Alone Wood Furnace, (see Section 5.2).

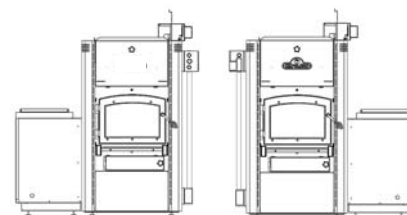

Hybrid HMF150/200 as a Combination Wood/Oil Furnace (see Section 5.3).

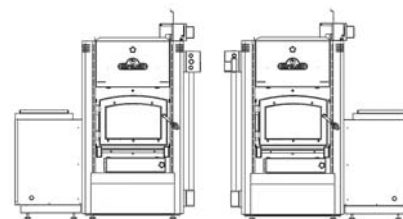

Hybrid HMF150/200 as a Combination Wood/Electric Furnace (see Section 5.4).

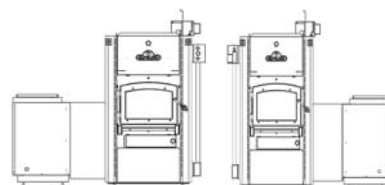

Hybrid HMF150/200 as a Combination Wood/Oil/Electric Furnace (see Section 5.5).

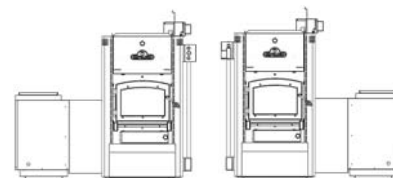

! WARNING

THE INSTALLATION OF THE FURNACE MUST BE DONE IN ACCORDANCE WITH RULES OF AUTHORITIES HAVING JURISDICTION AND THE CAN / CSA B365-01 (R2006) STANDARD FOR SOLID FUEL BURNING APPLIANCES AND EQUIPMENT.

THE HMF/CHMF 150/200 WOOD FURNACES ARE NOT INTENDED FOR USE AS AN "ADD ON" FURNACE TO A HEAT PUMP SYSTEM. CONNECTION OF THIS CONFIGURATION WILL VOID ALL WARRANTIES.

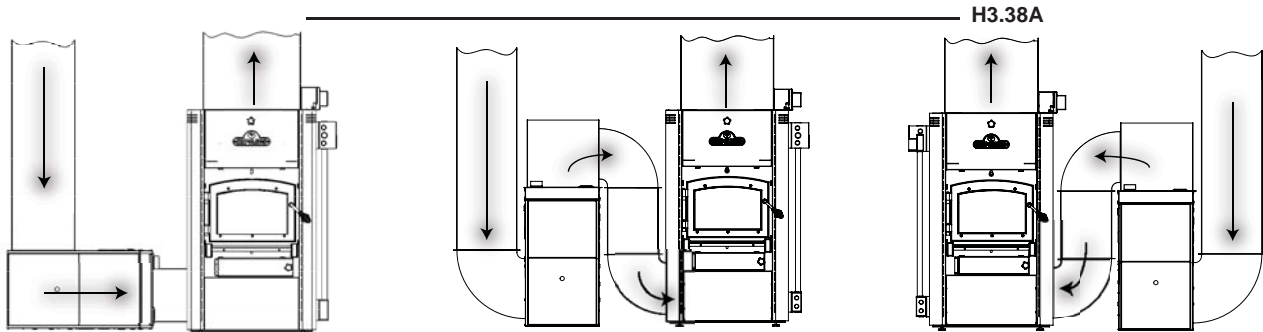

- REQUIRED COMPONENTS:
- HMF150/200 Hybrid Furnace
 - HMFK-ADDON Kit
 - HMFK-SOLID or HMFK-GLASS Door Kit

CAUTION

1. Certified for series connection to the supply plenum outlet only (upstream) of an oil-fired furnace or gas fired furnace, or electric furnace;
2. May be added onto one of the following:
 - a gas/oil fired furnace having an output, as shown on the original nameplate, between 60,000 minimum and 85,000 maximum BTU/h (HMF150), up to 100,000 BTU/h (HMF200)
 - an electric furnace having a rating as shown on the original nameplate, between 15 minimum and 20 maximum Kw (HMF150), up to 30 Kw (HMF200)
3. Do not connect duct work so that a reverse flow is possible
4. Operate the original furnace (oil, gas, electric) unit periodically to ensure that it will operate satisfactorily when needed;
5. Do not relocate, bypass or render inoperable any of the safety controls in the original furnace installation;
6. Maintain sufficient combustion-air supply to both furnaces. Air starvation is dangerous, see Section 3.2 "Outside Combustion Air";
7. Refer to manufacturer's instruction of existing furnace.
8. Do not use duct elbows having an inside radius of less than 6" inches (150mm).
9. An add-on unit shall only be installed on a furnace duct system and chimney that are in good operating condition.
10. a) The differential static pressure between the inside and outside of the warm air supply plenum, or the air-temperature rise at equilibrium across the original furnace is to be measured before any changes are made to the system. Using the following methods the differential of pressure and temperature should be adjusted to the same values after the add-on installation (meeting original manufacturer specifications) in order to maintain the air flow through the original furnace.
 - on a belt-driven system, blower pulleys and motor pulleys may be changed but the electrical current flowing through the motor shall not exceed the nameplate rating (a blower motor of larger power may be used);
 - on a direct-drive system, the motor shall not be changed; however, the speed of the motor may be increased;
 - the blower itself shall not be changed;

- the equipment shall be installed in accordance with the instructions of the original furnace manufacturer and in a manner acceptable to the regulatory authority by qualified personnel. The operation of the original furnace must be verified for acceptable operation before and after installation of the "Add On".
 - the installation shall comply with the applicable requirements of CSA Standard CAN CSA-B365. Changes made to the installation of the oil furnace shall comply with CSA Standard B139, changes made to installation of gas fired furnace shall comply with CGA Standard CAN/CGA-B149.1 or CAN/CGA-B149.2; changes made to the installation of the electric furnace shall comply with CSA Standard CSA C22.1.
10. b) When the circulation blower is turned on by the wood limit in "Add On" furnace, the blower speed (controlled through RG contacts), should provide air flow thru the combined system of 1100-1300 CFM (HMF150), and 1300-1700 CFM (HMF200).
 11. Certified for installation with the allowable duct work described in Section 6.0 - "Plenum and Venting Installation".
 12. **Do not connect** to any gas fired furnace that has not been certified initially as complying with Standard ANSI Z21.47 / CSA 2.3 or its' precedents.
 13. **Do not connect** to any furnace that is not equipped with an air circulation blower.
 14. **Do not connect** under any circumstances to the chimney or vent serving a gas furnace or gas appliance.
 15. **Disconnect power from both electric furnace and "Add On" furnace before servicing.**
 16. Refer to original furnace manufactures instructions regarding:
 - minimum duct sizes
 - permissible openings in casings for ducts
 - electric circuit diagrams to be used to determine connection points for circuit from "Add On"
 - electric ratings of control relays
 - minimum distance to flue pipe from electric furnace casing, power supplies and electric wiring
 - month and year of certification

STEP #1

The original furnace that "Add-On" furnace will attach to, must meet all specifications/parameters as outlined in the "CAUTION" section.

STEP #2

Series ducting of original furnace to "Add-On" furnace must be in adherence with "Allowable" venting configurations, as outlined in the "CAUTION" notes and instructions given in Section 6.0.

STEP #3

Ducting from original furnace to "Add-On" furnace, will transition to suit inlet opening on side of "Add-On" furnace.

STEP #4 - Electrical:

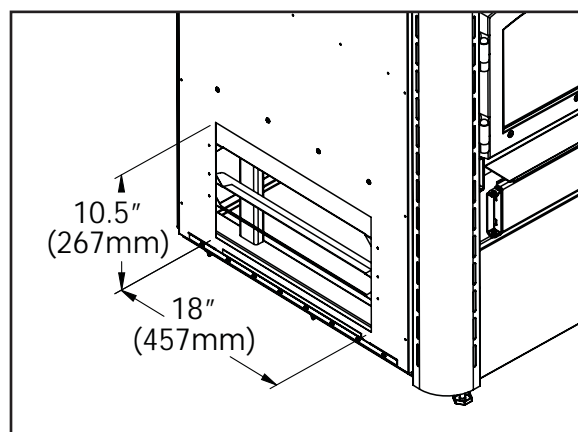

! WARNING

ORIGINAL FURNACE MUST SATISFY ALL SPECIFICATIONS/PARAMETERS DESCRIBED IN THE "CAUTION" NOTES AT THE BEGINNING OF SECTION 5.1.

ALL 115 VOLT ELECTRICAL PRE ASSEMBLED HARNESSSES MUST BE INSTALLED AS PER INSTRUCTIONS AND ELECTRICAL CODES.

NO 115V ELECTRIC CIRCUIT HARNESS OR FIELD WIRING MAY PASS THROUGH CLEARANCE SPACE BETWEEN HMF150 FURNACE BOTTOM AND FLOOR.

FAILURE TO COMPLY MAY RESULT IN ELECTRIC SHOCK, FIRE, PROPERTY DAMAGE OR PERSONAL INJURY.

! WARNING

INSTALLATION OF "ADD-ON" CONFIGURATION REQUIRES FIELD WIRING BY A CERTIFIED ELECTRICIAN. ALL WIRING TO CONFORM TO CSA 22.1.

H3.40

Install wood limit switch:

- Locate and drill a 7/8" hole in the side of the plenum on the same side as the location of the HMF150/200 main wire harness, as illustrated.

LEFT HAND RETURN AIR CONFIGURATION

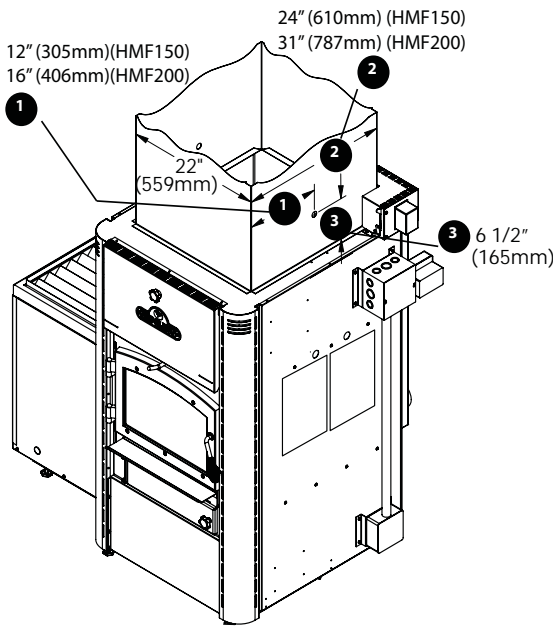

RIGHT HAND RETURN AIR CONFIGURATION

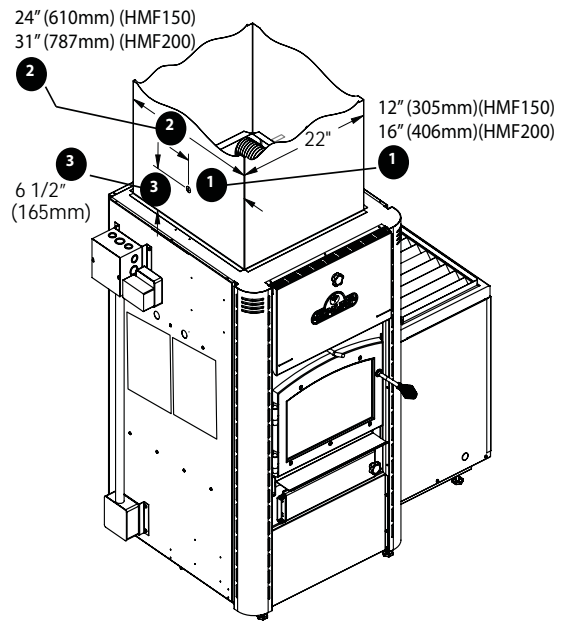

- Locate the wood limit switch bracket on the furnace top, next to the plenum by lining up the clearance holes in the lower switch bracket and the pilot holes in the furnace top (secure with hex head screws).
- Secure the top flange of the switch mounting bracket by fastening with 2 hex head self drilling screws into the supply plenum.
- Secure the wood limit switch onto the switch mounting bracket using 4 hex head wildrill screws.
- Secure the flex conduit connector on loose end of the wood limit wire harness to the access hole on bottom of the wood limit switch connection box using the lock nut from within the box.
- Connect the wires from the wood limit wire harness to the wood limit terminals as per the diagram.

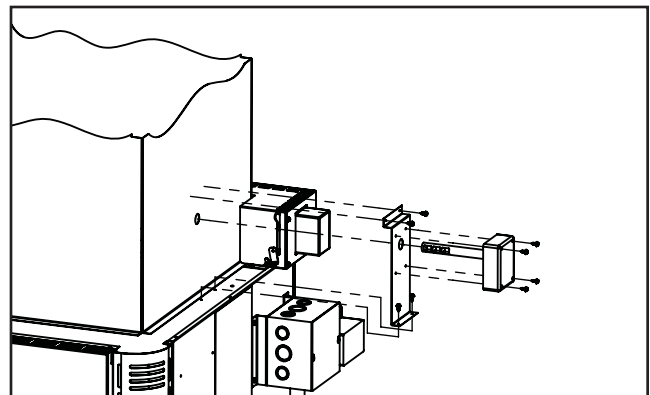

WOOD FAN/LIMIT WIRING

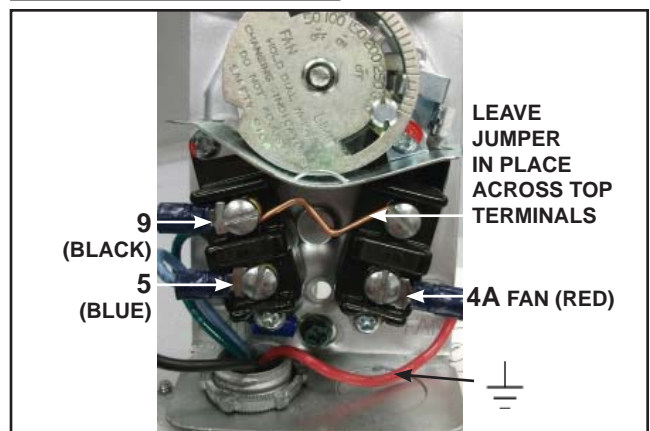

- Secure all flag connectors to switch terminals, and route ground line to switch chassis.
- Confirm the set points by checking to see if the straight edge of the pointer indicates the correct temperature listed.

CAUTION

THE PRESET VALUES ON THE FAN LIMIT CONTROL MUST NOT BE CHANGED FROM THE FACTORY SETTING.

ANY ADJUSTMENT TO THIS CONTROL WILL AFFECT THE OPERATING EFFICIENCY OF THE FURNACE AND WILL VOID THE WARRANTY COVERAGE.

WOOD FAN/LIMIT SET POINTS

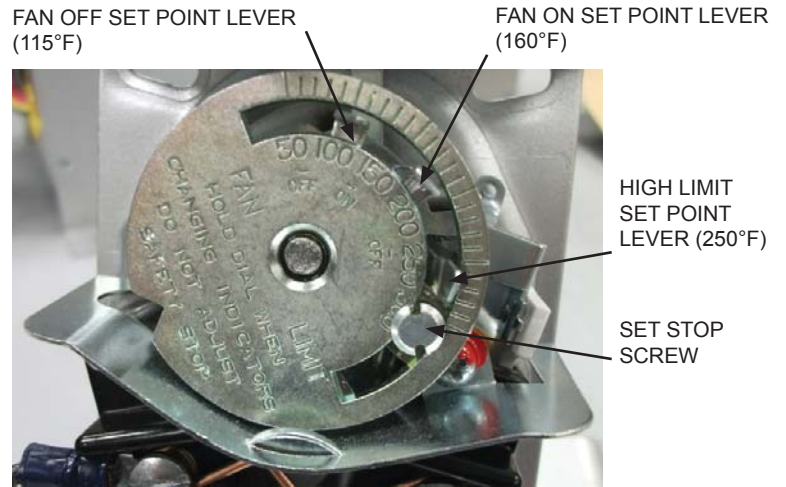

- Once set point limits have been confirmed, carefully manipulate wiring inside wood limit connection box so that installation of connection box cover does not disturb or impede mechanical set point tabs and rotary dial.
- **Make sure the fan switch is pulled out into the “AUTO” position. Please refer to “Control System - Summer Fan/Continuous Fan” section for more information.**

FOR FURNACE THAT IS NOT AC READY

- For furnaces that are not AC ready a fan control centre must be added to the original furnace.

IMPORTANT:
THIS STEP IS FOR "ADD-ON" CONFIGURATION ONLY!

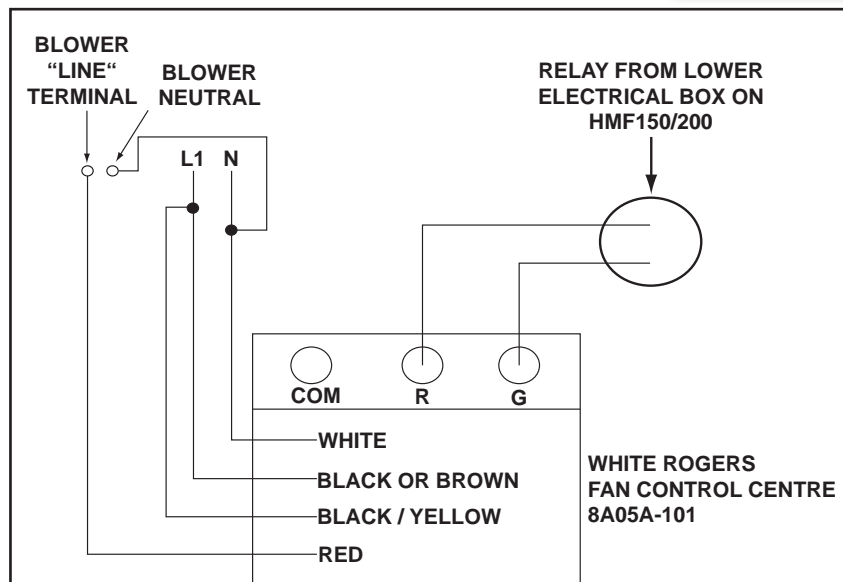

LOWER ELECTRICAL BOX - MAIN HARNESS HMF150/200

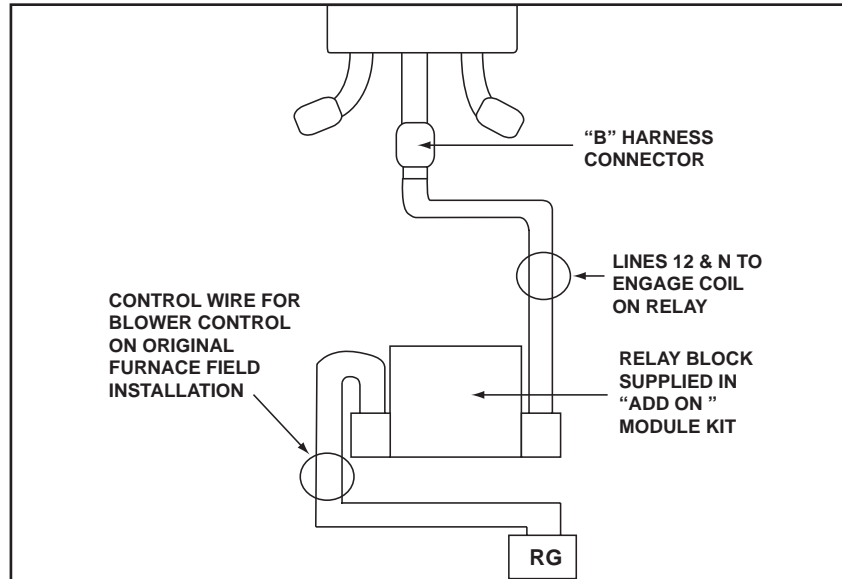
**NOTE**

- a) For ECM motor in original furnace
 - relay acts as dry contact for G contact on G13 control board.
- b) For PSC motor in original furnace (TYPE 8A05A-101)
 - spec White Rogers fan control centre supplied by installer
 - control wire can be from R&G contacts of fan centre to dry contact on relay in lower control box HMF150
- c) PRECAUTION - The new fan centre must have same power source as original furnace.
- d) Motor speed may need to be increased to overcome increased static pressure:
 - PSC - move to higher speed as needed
 - ECM - adjust taps or control as needed

NOTE

- Adjust the motor speed when operating the original furnace, so that temperature and pressure differential measured between warm air supply plenum remain the same before and after addition of the "Add On".
- Adjustment of motor speed when operating "Add On" should provide an airflow of 1100-1300 CFM thru the ducting system (HMF150), 1300-1700 CFM (HMF200).

5.2 HYBRID HMF150/200 AS A "STAND ALONE" WOOD FURNACE

REQUIRED COMPONENTS:

- HMF150/200 Hybrid Furnace
- HMFK-BMP50-1 Blower Box Module
- HMFK-SOLID or HMFK-GLASS Door Kit

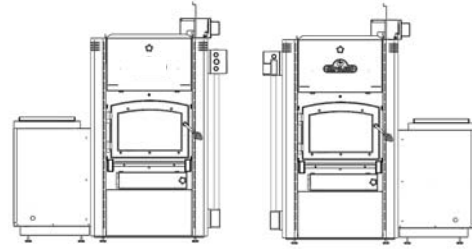

STEPS: Completely assemble HMF150/200 in required left or right hand "RA" configuration as required.

STEP #1 - #4

Follow Steps 1 to 4 from SECTION 5.1 - HYBRID HMF150/200 AS A "ADD ON" TO EXISTING FURNACE.

STEP #5

- Locate and level the HMF150/200 while maintaining a minimum 1.25" (32mm) clearance space between the bottom of the furnace and floor.
- Use levelling the legs to compensate for uneven floor and snug lock nuts up to the furnace base to prevent movement through vibration.
- Remove the contents of the blower module kit and compare with the contents list on the "Manual" addendum, accompanying the Blower Module.
- Remove the shipping bracket from the blower.

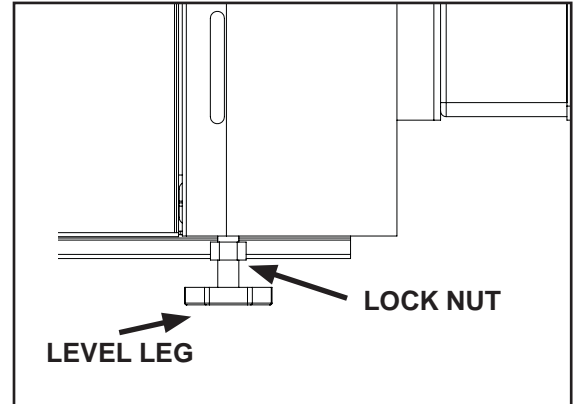

STEP #6

- Place the blower box module with the blower outlet side facing the rectangular opening on the side panel.
- Adjust the levelling legs on the blower box module so that the module is level and clearance hole on the mounting flanges align with pilot holes on side of the furnace panel.

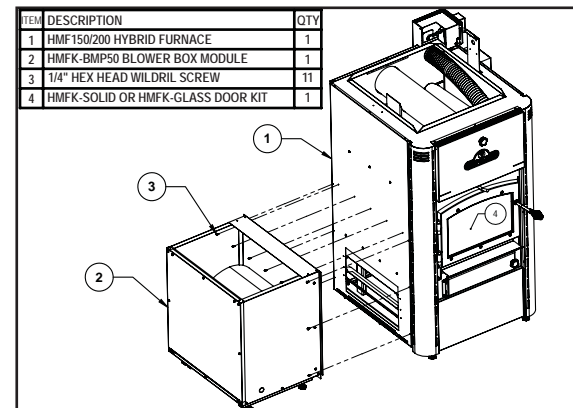

STEP #7

- Lift the blower outlet side of blower box so mounting flange on the bottom of blower box clears the retaining bracket on the lower edge of the furnace side.
- Slide the blower box in so the lower mounting flange of the blower box is contained between the flange of the retaining bracket and the furnace side.
- Fasten the sides and top mounting flanges of the blower box using wildrill 1/4" hex head screws.

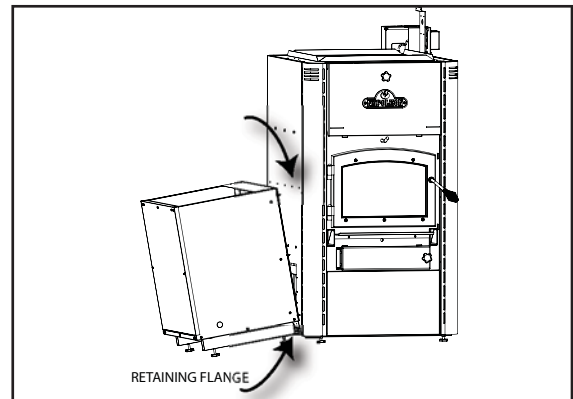

WARNING

THE INSTALLATION OF THE WOOD FURNACE / COMBINATION WOOD FURNACE MUST BE DONE IN ACCORDANCE WITH RULES OF AUTHORITIES HAVING JURISDICTION AND THE CAN / CSA B365-01 (R2006) STANDARD FOR SOLID FUEL BURNING APPLIANCES AND EQUIPMENT.

STEP #8

- Remove the access panel from the rear of the blower box module.
- Route the harness from the rear of the lower electrical box of the main electric harness to access the hole on the side of blower box.
- Match and connect the harness connectors "B" inside the lower electrical box and snap the flex conduit connector into the side of the electrical box.
- Wires from the other end of the harness should pass through the hole in side of the blower module. The 90° flex connector should also be passed through and secured by the connector nut on the inside of box.

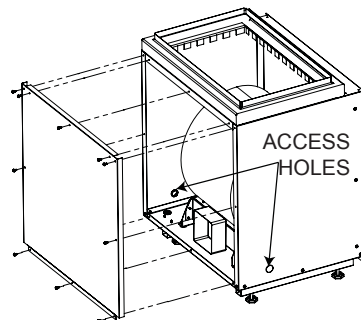

"B" HARNESS LENGTH: ADJUSTMENT WHEN NOT USING ELECTRIC FURNACE MODULE

- The length of "B" harness has been made to allow for installation of an Electric Furnace Module (HMFK-EF15/18/20/25). If Electric Furnace Module is not being installed, the length of flex conduit needs to be reduced by 12" (305mm). Remove the 90° bulk head connector from end of flex conduit, slide the liner off wires far enough that the wiring will not be damaged when adjusting the length of flex conduit. Measure 12" (305mm) off end of the flex conduit and put small break/kink in the conduit at this point using side cutters or hacksaw blade. The conduit can then be flexed back and forth over this break until it breaks completely apart, and the 12" (305mm) section can be removed. Feed the wires back through the flex conduit and relocate the 90° head connector bracket to the new end of the flex conduit.
- Copy the wire, marking number, located near the end of each wire, onto a piece of masking tape and stick this marker 14" (355mm) away from wire end. The wire can now be shortened by 12" (305mm).

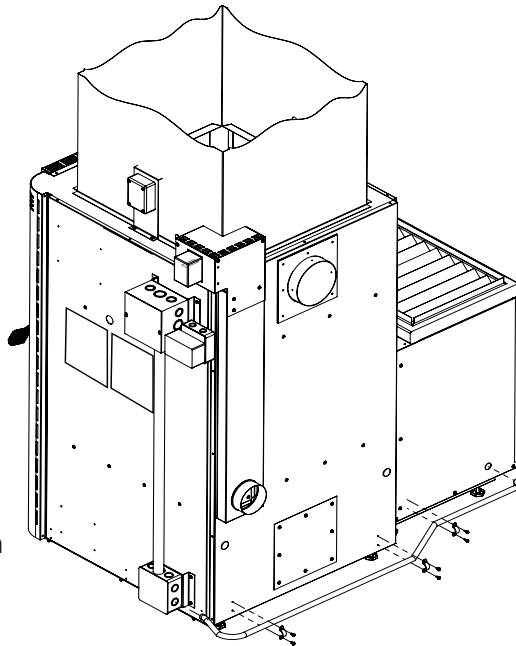

! WARNING

ENSURE THE ELECTRICAL WIRING INSIDE THE BLOWER BOX IS ADEQUATELY SECURED AND PROTECTED FROM SHARP EDGES. FAILURE TO DO SO COULD RESULT IN DAMAGE TO THE WIRING INSULATION, RESULTING IN POSSIBLE SHORT CIRCUITING TO THE FURNACE CHASSIS. THIS COULD RESULT IN POSSIBLE INJURY OR PROPERTY DAMAGE.

ALL 115 VOLT ELECTRICAL PRE ASSEMBLED HARNESSSES MUST BE INSTALLED AS PER INSTRUCTIONS AND ELECTRICAL CODES.

NO 115V ELECTRIC CIRCUIT HARNESS OR FIELD WIRING MAY PASS THROUGH CLEARANCE SPACE BETWEEN HMF150/200 FURNACE BOTTOM AND FLOOR.

FAILURE TO COMPLY MAY RESULT IN ELECTRIC SHOCK, FIRE, PROPERTY DAMAGE OR PERSONAL INJURY.

H3.42

STEP #9

- See SECTION 6.0 - PLENUM AND VENTING INSTALLATION.

STEP #10

- See SECTION 7.0 - ELECTRICAL CONNECTIONS AND SCHEMATICS.

STEP #11

- See SECTION 8.0 - OPERATING INSTRUCTIONS.

5.3 HYBRID HMF150/200 AS A COMBINATION "WOOD/OIL" FURNACE

! WARNING

THE INSTALLATION OF THE WOOD OIL COMBINATION FURNACE MUST BE DONE IN ACCORDANCE WITH THE RULES OF THE AUTHORITIES HAVING JURISDICTION AND THE CAN / CSA B139-09 STANDARD FOR OIL BURNING HEATING APPLIANCES.

EN

H3.43

REQUIRED COMPONENTS:

- HMF150/200 Hybrid Furnace
- HMFK-BMP50-1 Blower Box Module
- HMFK-OFRF40 or HMFK-OFBNX Oil Burner Module
- HMFK-SOLID or HMFK-GLASS Door Kit
- HMFK-CMBCH-1 (HMF150) or HMFK-CCH200 (HMF200) Oil Combustion/Heat Exchanger
- HMFK-WMO WMO Thermal Safety Switch

STEPS #1 - #9

Follow Steps 1 to 9 from SECTION 5.2 - HYBRID HMF150/200 AS A "STAND ALONE" WOOD FURNACE.

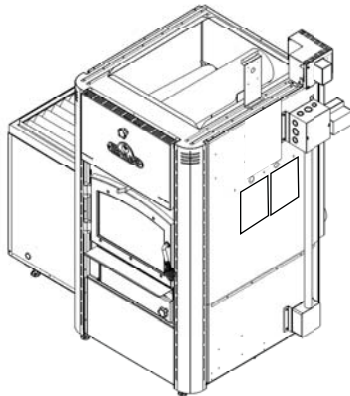

LEFT HAND RA

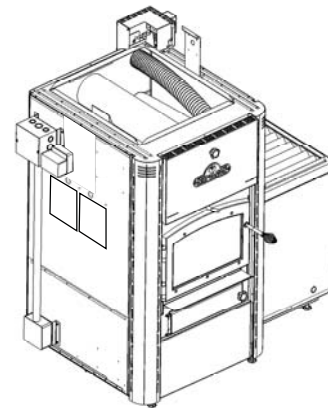

RIGHT HAND RA

STEP #10

- Remove the contents of the Oil Burner Module Kit (HMFK-OFRF40 or HMFK-OFBNX) and compare with the contents list on the "Manual" Addendum accompanying the Oil Furnace Module.

STEP #11

- Remove (6) hex head screws fastening the bottom front panel to the front corner post and pull the bottom front panel off HMF150/200 furnace assembly.
- Remove the oil flue blanking plate off the rear furnace panel (remove 8 hex screws from the blanking plate).

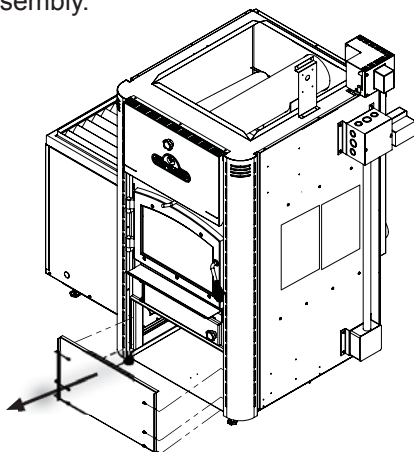

LEFT HAND RA

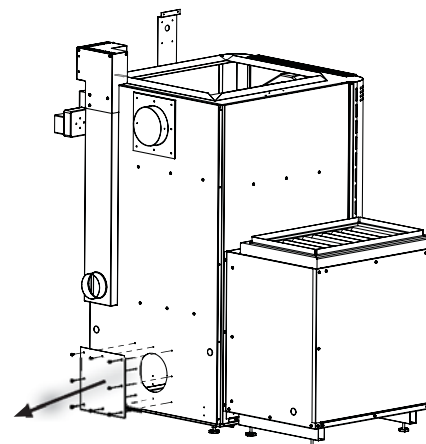

LEFT HAND RA REAR VIEW

STEP #12

- Insert the stainless steel oil furnace combustion chamber/heat exchanger HMFK-CMBCH-1 (HMF150) or HMFK-CCH200 (HMF200), into the lower cavity of HMF150/200 body (see diagrams). Ensure the heat exchanger is on the same side as the blower.

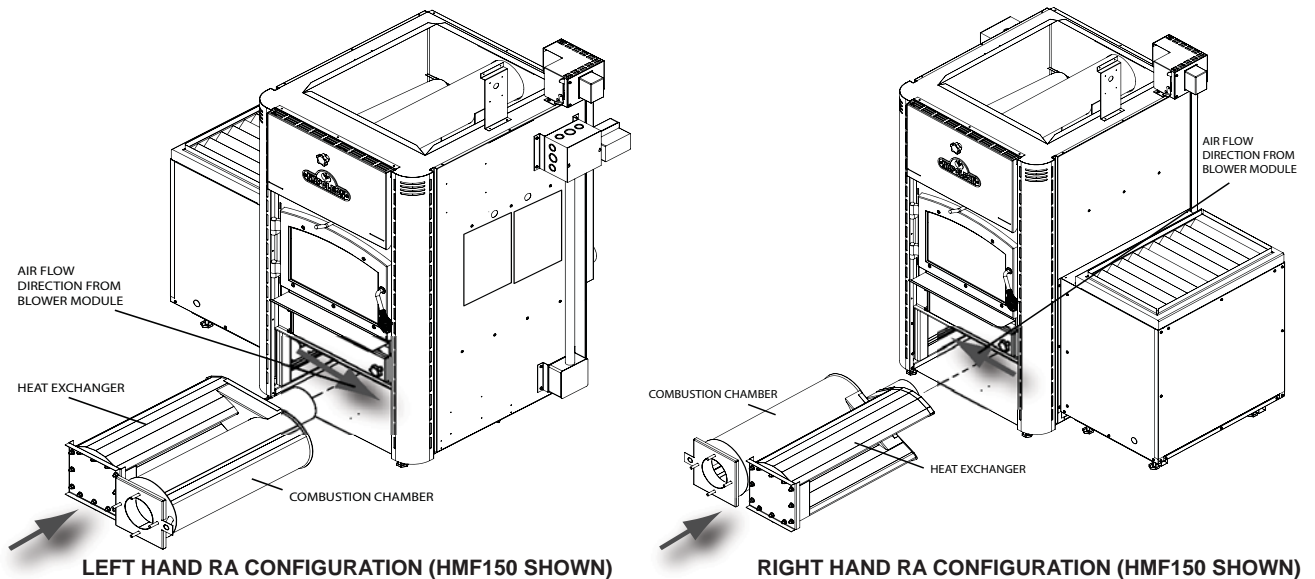

! WARNING

TAKE PARTICULAR CARE TO ORIENTATE OIL FURNACE AS PER DIAGRAMS FOR LEFT AND RIGHT HAND RA. THE OIL FURNACE COMBUSTION CHAMBER AND HEAT EXCHANGER WAS DESIGNED AND TESTED FOR THE EXCHANGER SECTION OF THE ASSEMBLY TO FACE THE AIR STREAM COMING FROM THE BLOWER MODULE. INCORRECTLY ASSEMBLED OIL FURNACE COMPONENTS CAN RESULT IN POOR PERFORMANCE AS WELL AS COMPONENT AND/OR PROPERTY DAMAGE.

H3.44

- Push the oil combustion chamber/heat exchanger into the cavity until the flue pipe protrudes through the opening of the rear furnace panel.

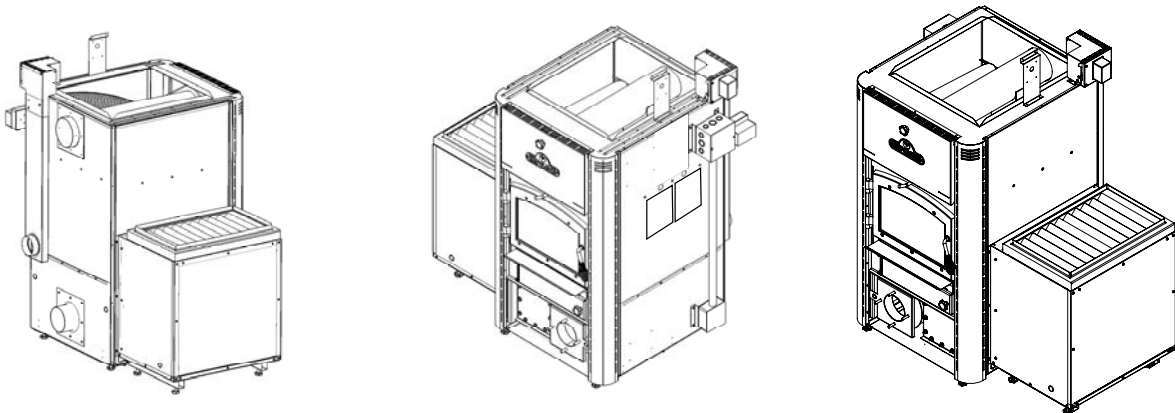
**STEP #13**

- Align mounting flange and bolts with flange pattern on new bottom front panel (supplied) with HMFK-OFRF40, HMFK-OFBNX module kits in both left and right hand RA versions.

- Locate flange gasket over bolts of oil furnace mounting flange, prior to placing bottom front cover up to mounting flange.
- Align mounting bolts on flange align with clearance holes in bottom front panel when panel loosely fit in final position.
- Correct position of bottom front panel has top flange of panel over top of firebox front flange and underneath furnace bottom.
- New bottom front panels in oil furnace module kits.

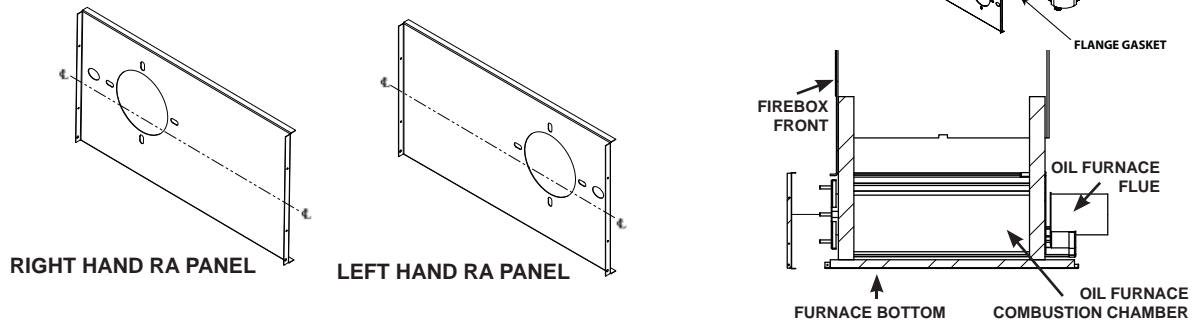
**NOTE**

Not all oil burner module kits require adapter collar and second fibre gasket. Check "Manual" Addendum accompanying oil furnace module for specific assembly details.

STEP #14A

- When using the Riello Oil Burner (kit # HMFK-OFRF40), the burner mounting flange must be located so that the mounting surface of the flange is 2.5" (63.5mm) from the firing end of the blast tube (combustion head). See diagram.

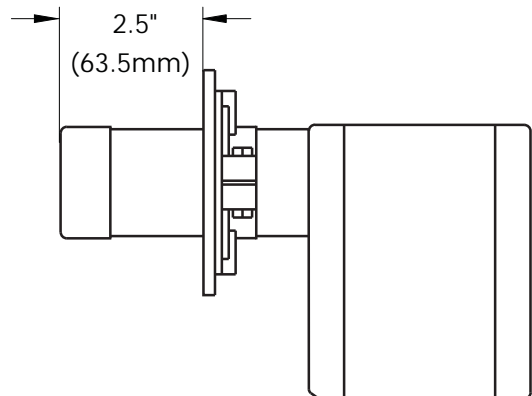
**STEP #14B**

- Fasten bottom front cover to corner posts using hex head wildrill screws. Assemble burner, flange adapter collar (used with Riello Burner only - kit # HMFK-OFRF40), and gaskets to oil furnace mounting flange bolts as per diagram.
- Attach oil furnace sight glass, gasket, and bracket to bottom front panel using (2) hex screws.

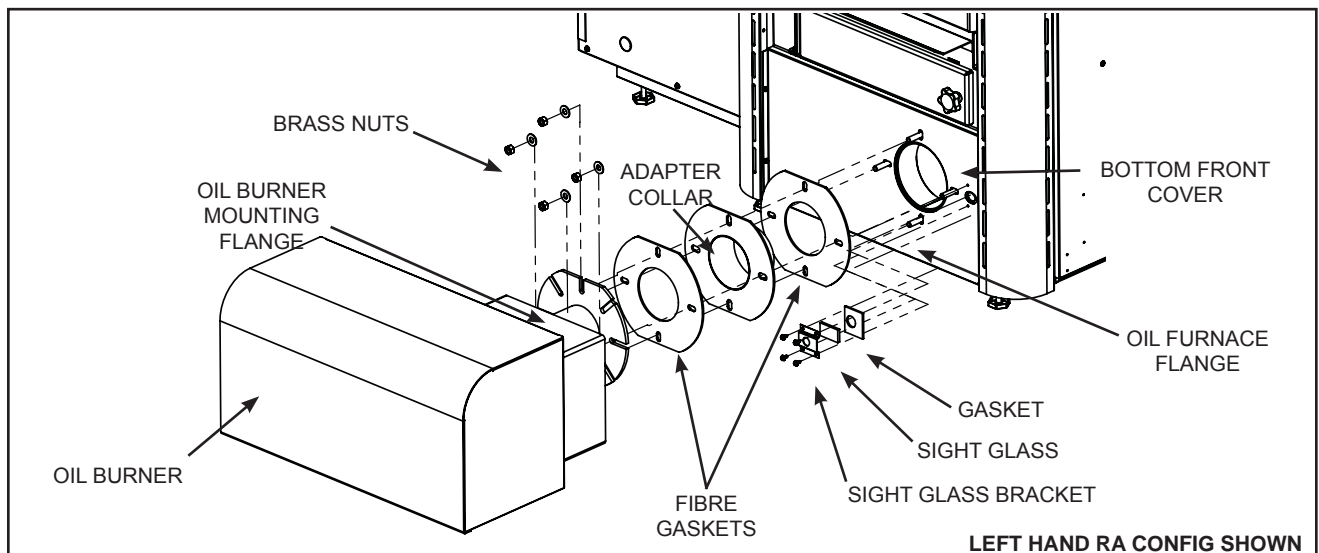

! WARNING

ALL 115V ELECTRICAL PRE ASSEMBLED HARNESSSES MUST BE INSTALLED AS PER INSTRUCTIONS.

NO 115V ELECTRIC CIRCUIT HARNESS OR FIELD WIRING MAY PASS THROUGH CLEARANCE SPACE BETWEEN HMF150/200 FURNACE BOTTOM AND FLOOR.

FAILURE TO COMPLY MAY RESULT IN ELECTRIC SHOCK, FIRE, PROPERTY DAMAGE OR PERSONAL INJURY.

STEP #15

H3.45

NOTE

Wire harness "C", which runs from junction box and oil furnace burner, has been supplied at the length required for a right hand RA configuration. If installing oil furnace with a left hand RA configuration, the wires in the harness and the flex conduit will have to be shortened by approximately 12" (305mm). Attach harness to junction box and secure conduit on HMF150/200 to determine actual length of wires and flex conduit.

- Route Harness "C" between oil burner and lower electrical box of HMF150/200 electrical harness.
- Match and connect harness connectors "C" inside the lower electrical box and snap flex conduit connector into side of electrical box.
- Flex conduit shall be secured along bottom edge of side panel by screwing cable straps over flex conduit - use dimples provided to locate screws holding cable straps.
- Wires from other end of harness should pass through appropriate bulk head on frame of oil burner, and the flex conduit shielding secured to the bulk head by the 90° flex connector. Connector should be secured from other side of bulk head by connector nut.
- Power, neutral and ground connections should be made to oil burner controls as per installation/owner manual for specific oil burner.
- Flex conduit should be secured to floor where conduit passes under the oil furnace modules protective cover. The flex conduit should pass directly below the notched relief in the side of the protective cover.

LEFT HAND RA CONFIGURATION

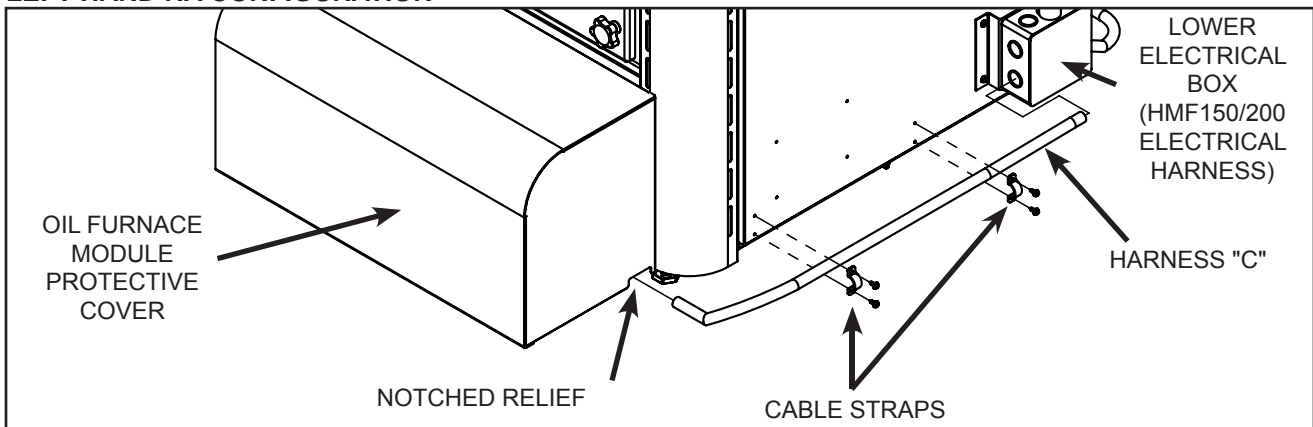

RIGHT HAND RA CONFIGURATION

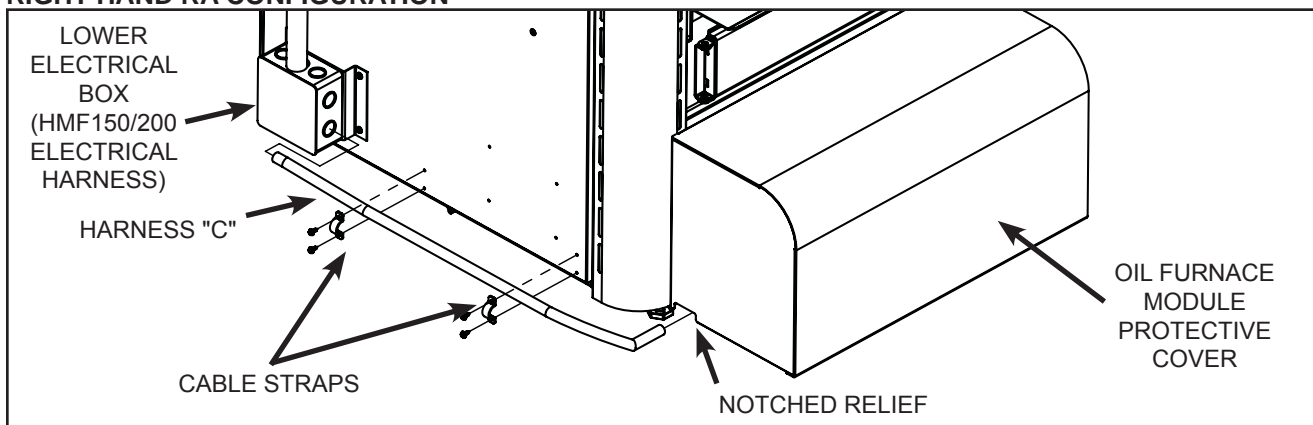

STEP #16

⚠ WARNING

THE MOUNTING LOCATION AND MOUNTING BRACKET FOR THE OIL LIMIT SWITCH ARE NOT THE SAME FOR THE HMF150 AND HMF200. STRICTLY ADHERE TO THE INSTRUCTION SET PERTAINING TO THE MODEL BEING INSTALLED. FAILING TO DO SO COULD RESULT IN POOR OPERATION, PROPERTY DAMAGE AND PERSONAL INJURY.

EN

H3.46

- Slide the cover of the oil limit switch off.

FOR HMF150 ONLY:

- Attach the oil limit switch to the oil limit switch mounting bracket (W080-1101P supplied with HMFK-CMBCH-1 Oil Furnace Combustion Chamber) using (4) hex head wildrill screws, see following diagram for correct mounting position depending on left or right hand RA requirement.

HMF150

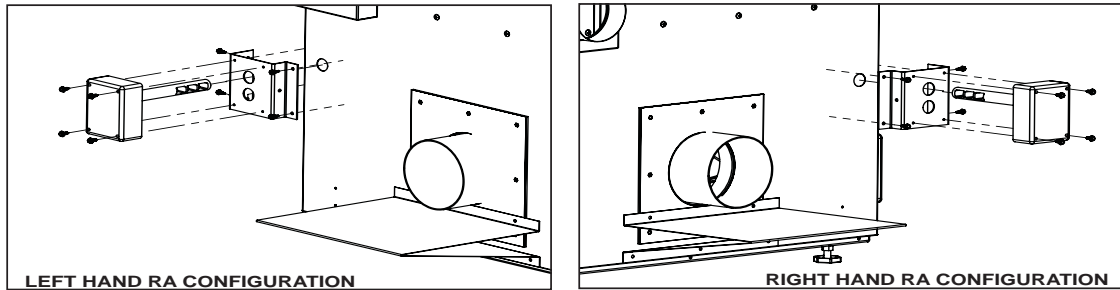

FOR HMF200 ONLY:

- Attach the oil limit switch to the oil limit switch mounting bracket (W080-1170-SV1MT supplied with HMFK-CCH200 Oil Furnace Combustion Chamber) using (4) hex head wildrill screws, see following diagram for correct mounting position depending on left or right hand RA requirement.

HMF200

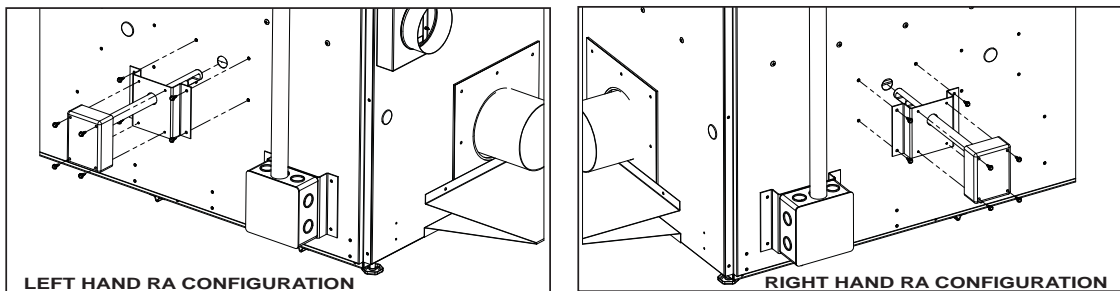

- Insert the cylindrical probe of limit switch/bracket assembly into the appropriate 7/8" hole in the panel (see above diagram). Once seated, the bracket can be secured to the panel using (4) self drilling screws.
- Secure the flex conduit connector on loose end of oil limit wire harness to the access hole on bottom of oil limit switch connection box using lock nut from within box.
- Connect the wires from the oil limit wire harness to the oil limit terminals as per Figure A.
- Secure all the flag connectors to the switch terminals and route the ground line to the switch chassis.
- Confirm the set points by checking to see if the straight edge of the pointer indicates the correct temperature listed in Figure B.

HMF150

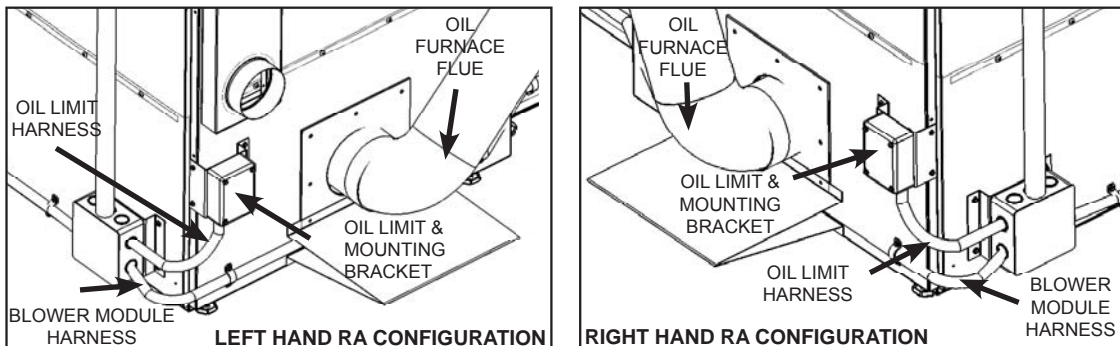

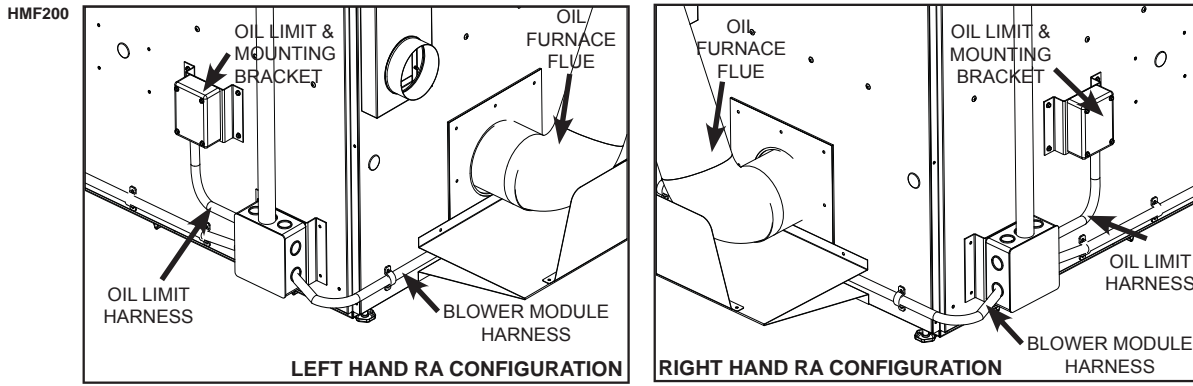

FIGURE A - OIL FAN/LIMIT WIRING

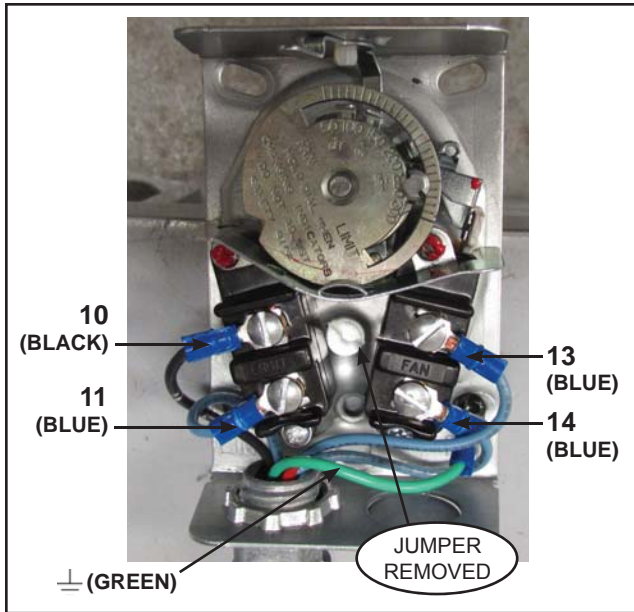
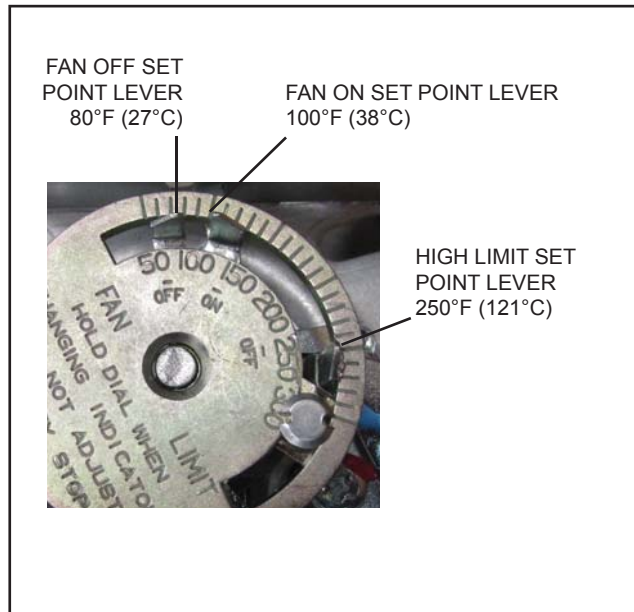

FIGURE B - OIL FAN/LIMIT SET POINTS



CAUTION

THE PRESET VALUES ON THE FAN LIMIT CONTROL MUST NOT BE CHANGED FROM THE FACTORY SETTING.

ANY ADJUSTMENT TO THIS CONTROL WILL AFFECT THE OPERATING EFFICIENCY OF THE FURNACE AND WILL VOID THE WARRANTY COVERAGE.

- Once the set point limits have been confirmed, carefully manipulate the wiring inside the oil limit connection box so that installation of the connection box cover does not disturb or impede the mechanical set point tabs and the rotary dial.
- **Make sure the fan switch lever is in the “AUTO” position. Please refer to “Control System - Summer Fan/Continuous Fan” section for more information.**

STEP #17

Sealing the oil flue and mounting lower heat shield:

- Slide the flue fibre gasket over on the flue.
- Slide the flue plate over the oil furnace flue pipe.
- Secure the 5" (127mm) flue plate to the rear panel using hex head screws (8 pcs.).

NOTE

Clearance holes in the 5" (127mm) flue plate cover may not align perfectly with the original pilot holes in rear face of the rear panel. There is adequate clearance between the oil furnace flue and the flue exit hole in the rear panel to accommodate any misalignment between the two caused by standard fabrication tolerances. Providing the gap between the flue and the rear panel is completely sealed by sandwiching fibre gasket between the two. It is permissible to drive new holes into the rear panel using self drilling screws.

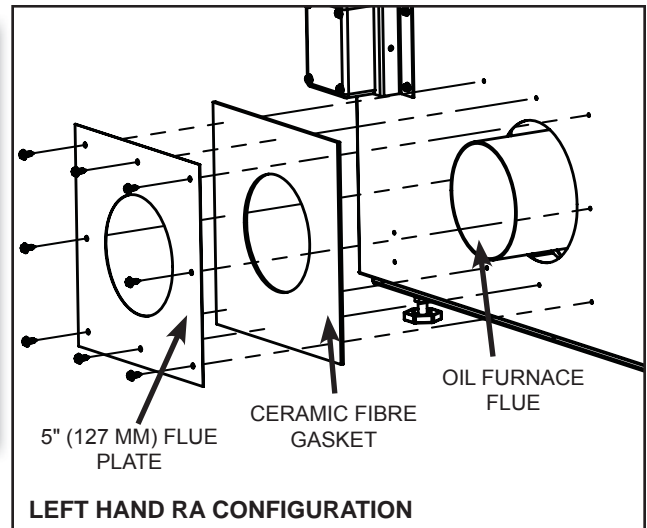

- Locate and secure lower heat shield per diagrams.

⚠ WARNING

WHEN CONFIGURING A HM150/200 FURNACE WITH THE OIL FURNACE MODULE, IT IS ABSOLUTELY IMPERATIVE THAT THE OIL FLUE HEAT SHIELD IS INSTALLED CORRECTLY TO MAINTAIN CLEARANCES BETWEEN OIL FLUE AND COMBUSTIBLE FLOOR.

H3.47

- Secure heat shield using 1/4" hex head self drilling screws.

LEFT HAND RA CONFIGURATION

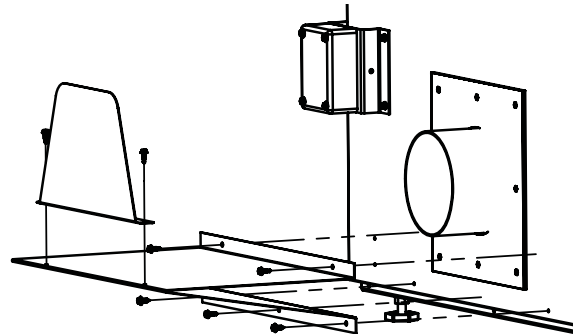
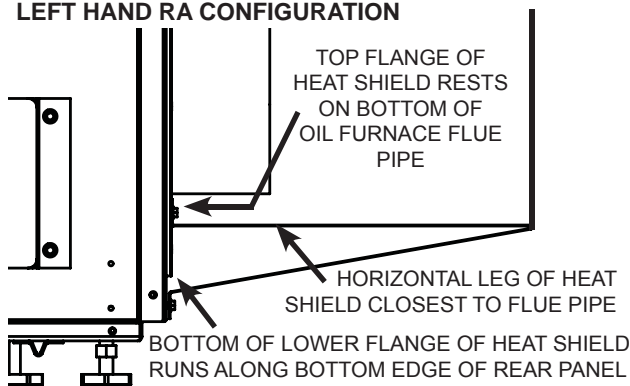

- For installation of oil furnace module in an Right Hand RA Configuration an additional heat shield shall be added to the rear of the primary air control housing, see diagrams for details.

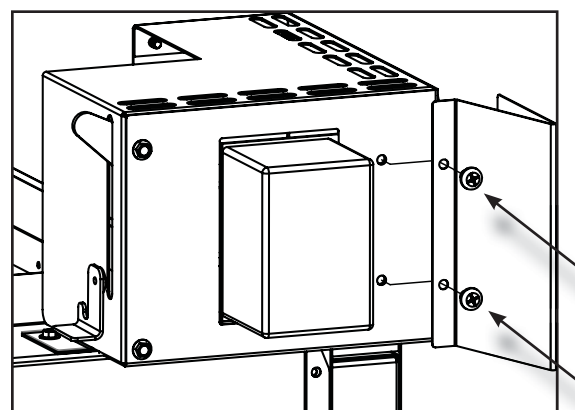
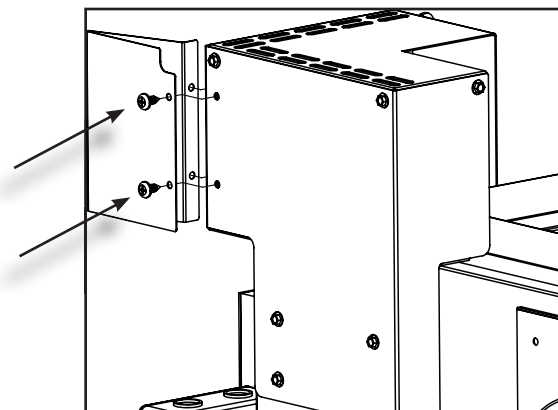

STEP #18

! WARNING

ALL INSTALLATION AND MAINTENANCE MUST BE PERFORMED BY A QUALIFIED/LICENSED INSTALLER. INCORRECT INSTALLATION, ADJUSTMENT, AND USE OF THE OIL BURNER COULD RESULT IN SEVERE PERSONAL INJURY, DEATH OR SUBSTANTIAL PROPERTY DAMAGE FROM FIRE, CARBON MONOXIDE POISONING, SOOT OR EXPLOSION.

H3.48

Connecting fuel to the oil module burner:

- Storage tank: construction, location, size, inlet/vent sizing, in line filters, shut off's and safety valves are dictated by the authority having jurisdiction and standards set by CSA B139-09 and NFPA31 (Note: minimum distance between the oil storage tank and the solid fuel furnace is 5 ft. 1.52m), B365-10, section 7.2.5).
- Plumbing:
 - Piping between the storage tank and the oil burner shall consist of 3/8" or 1/2" pipe (pipe specifications as per local authority and CSA 139-09).
 - Joins in piping should be kept to absolute minimum,
 - Flare fittings are permissible, CAUTION: COMPRESSION FITTINGS SHALL NOT BE USED.
 - For pipe thread fittings the use of pipe dope is required, CAUTION: TEFLON TAP SHALL NOT BE USED.
- Choosing 3/8" or 1/2" diameter pipe, single line (gravity feed) or two line (lift system).
 - Pipe sizing and type of plumbing system is dependant upon distance between the storage tank, burner and relative elevation between the storage tank and the burner.
 - Single line systems are typical of gravity fed burners (storage tank outlet above burner inlet), where as two line systems are more typical where piping lengths are excessive or suction lines start below the level of the oil burner.
 - For more detail on which method is more suited for a particular installation, see appropriate burner manual accompanying the oil burner, in the oil furnace module kit.
 - Details on installation and priming of given piping arrangement, also given in specific burner manual.

STEP #19

OIL BURNER SET UP AND STARTING PARAMETERS:

BURNER MODEL	INPUT @ 140,000 BTU/ US GAL	NOZZLE (DELVAN)	PUMP PRESSURE (PSI)	INLET AIR DAMPER SETTING	CO ₂ %	STACK TEMP (°F)	STACK DRAFT (W.C.)	SS EFFICIENCY (%)	OUTPUT
RIELLO 40F3	64,400	0.4 / 60°A	135	2			-0.02 TO -0.04	85%	54,740
	77,000	0.5 / 60°A	120	1.8			-0.02 TO -0.04	83%	63,910
	* 91,000	0.65 / 60°A	120	2	12 TO 14	500 - 550	-0.02 TO -0.04	82%	74,620
BECKETT NX	91,000	0.50 / 60°A	170	2	12 TO 14	615	-0.02 TO -0.04	82%	74,620

* AS EQUIPPED: TO SET AT ZERO SMOKE SET UP TO TRACE AND BACK OFF 2% CO₂

H12.13.1

! WARNING

ALL TROUBLE SHOOTING AND REPAIR MAINTENANCE MUST BE PERFORMED BY A QUALIFIED/ LICENSED SERVICE PERSON.

H3.49

STEP #20

- See SECTION 6.0 - PLENUM AND VENTING INSTALLATION.

STEP #21

- See SECTION 7.0 - ELECTRICAL CONNECTIONS AND SCHEMATICS.

STEP #22

- See SECTION 8.0 - OPERATING INSTRUCTIONS.

5.4 HYBRID HMF150/200 AS A COMBINATION "WOOD/ELECTRIC" FURNACE

- REQUIRED COMPONENTS:
- HMF150/200 Hybrid Furnace
 - HMFK-BMP50 Blower Box Module
 - HMFK-EF15, -EF18, -EF20, -EF25 Electric Furnace Module
(HMFK-EF15 for the HMF150 only, and HMFK-EF25 for HMF200 only)
 - HMFK-SOLID or HMFK-GLASS Door Kit

STEPS #1 - #4

Follow Steps 1 to 4 from SECTION 5.1 - HYBRID HMF150/200 AS AN "ADD ON" TO EXISTING FURNACE.

STEP #5

- Completely assemble HMF150/200 in required left or right hand "RA" configuration as required.
- Locate and level HMF150/200 while maintaining minimum 1.25" (32mm) clearance space between bottom of furnace and floor.
- Use the levelling legs to compensate for uneven floor and snug the lock nuts up to furnace base to prevent movement through vibration.

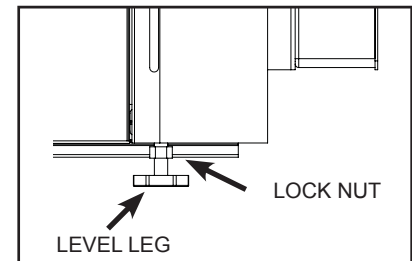

STEP #6

- Remove contents of the blower module kit and compare with contents list on "manual" addendum accompanying the blower module.

STEP #7

- Remove contents of the electric furnace module kit and compare with contents list on "manual" addendum accompanying the electric furnace module. Refer to step 1.2 for installation instructions for the pressure differential switch probe according to either left or right RA configuration.

STEP #8

- Place the blower module and the electric furnace module beside each other as per diagram:

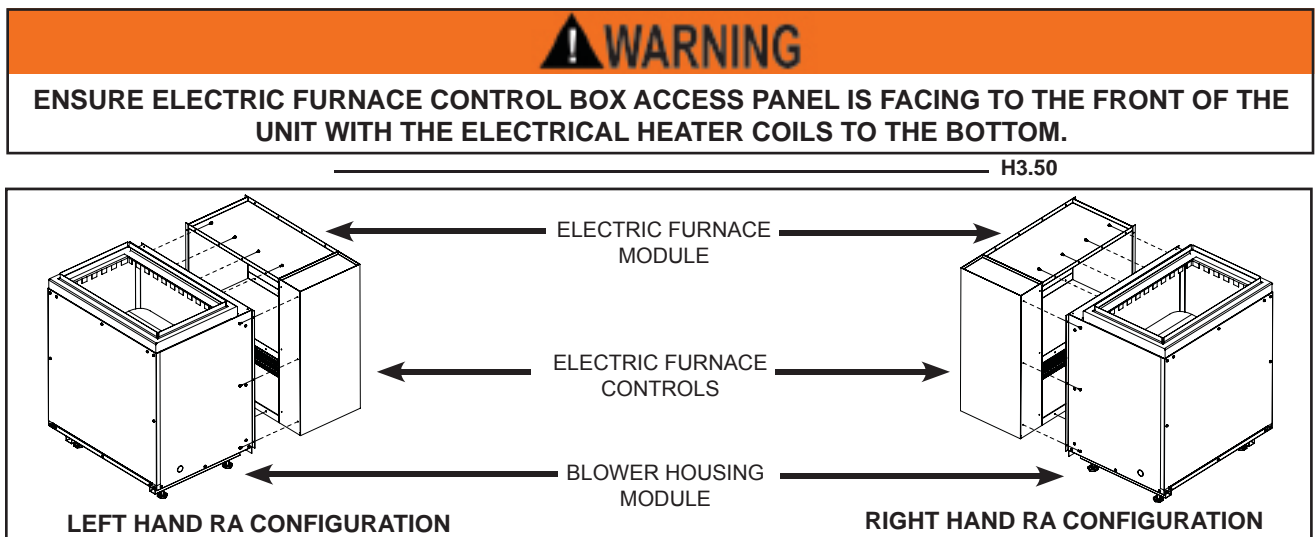

- Align holes in the adjacent top and side flanges, and secure with 9 x 1/2" hex head wildrill screws.

NOTE

Top/bottom flange screws thread into blower. Side flange screws thread into electric unit.

STEP #9

- Place the open side of electric furnace against rectangular inlet window on the side panel of HMF150/200 furnace. Adjust the levelling legs on the blower box module so that the electric furnace module is level and holes on the mounting flanges align with pilot holes on side of furnace panel.

STEP #10

- Lift open side of electric furnace module so as to allow mounting flange on bottom edge of electric furnace box to clear top edge of retaining bracket fastened to the lower edge of the rectangular window, the furnace side.
- Lower the electric furnace/blower box assembly so the lower mounting flange of the electric furnace is contained between the flange of the retaining bracket and the furnace side.
- Align and fasten side and top mounting flanges of the electric furnace module to the furnace side using 9 x 1/2" hex head wildrill screws.

STEP #11

 WARNING
ALL ELECTRICAL WIRING AND CONNECTIONS MUST BE DONE BY A QUALIFIED ELECTRICIAN.
THE ELECTRICAL INSTALLATION MUST SATISFY ALL RELEVANT ASPECTS OF CSA 22.1 AND IN PARTICULAR CAN/CSA-C22.2 NO. 0-M91, NO. 3-M1986.
ALL 115V PRE ASSEMBLED ELECTRICAL HARNESSES MUST BE INSTALLED AS PER INSTRUCTIONS. NO 115/220V ELECTRIC CIRCUIT (HARNESS OR FIELD WIRING) MAY PASS THROUGH CLEARANCE SPACE BETWEEN FURNACE BOTTOM AND FLOOR.
DISCONNECT POWER FROM BOTH ELECTRIC FURNACE AND "ADD ON" FURNACE BEFORE SERVICING.
FAILURE TO COMPLY MAY RESULT IN ELECTRICAL SHOCK, FIRE, PROPERTY DAMAGE OR PERSONAL INJURY.
ALL WIRING BRINGING 120V OR GREATER TO THE HMF150/200 AND ITS MODULES, SHALL BE AS SPECIFIED IN ELECTRICAL CODE BUT MUST HAVE WIRE INSULATION VALUE OF NO LESS THAN 194°F (90°C).
MUST MAINTAIN A MINIMUM CLEARANCE OF 12" (305MM) BETWEEN ELECTRIC WIRING CARRYING 120V OR GREATER AND ALL SURFACES OF THE SUPPLY PLENUM AND DUCT WORK.
MAINTAIN MINIMUM 18" (457MM) CLEARANCE BETWEEN ALL FURNACE EXHAUST COMPONENTS AND ELECTRICAL WIRING CARRYING 120V OR GREATER.

H3.51

- Remove access panel from the side of blower box module.
- Route harness "B" from lower electrical box of main electric electrical harness to access hole on the rear of blower box.
- Match and connect harness connectors "B" inside the lower electrical box and snap flex conduit connector into side of electrical box.
- Wires from other end of harness should pass through hole in rear of blower module, the 90° flex connector should also be passed through and secured by connector nut on the inside of box.
- Refer to section 7.3 for blower box wiring connections.

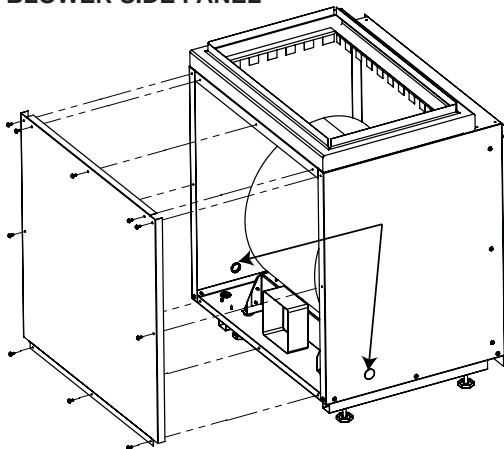
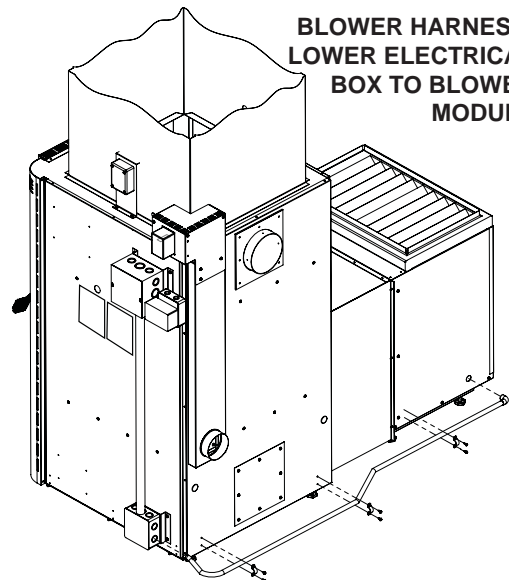
BLOWER SIDE PANEL**BLOWER HARNESS:
LOWER ELECTRICAL
BOX TO BLOWER
MODULE**

STEP #12

- See SECTION 6.0 - PLENUM AND VENTING INSTALLATION.

STEP #13

Fan Contact Wiring:

- Take the wire harness (red, red, green) supplied in the Electric Furnace Kit and feed one end through the front electrical knock out in the base of the electric furnace module and secure the conduit fitting with the locknut.
- Feed the other end of the harness through the bottom electrical knock out in the base of the blower box module and secure the conduit fitting with the locknut.
- In the electric furnace module hard wire the harness wires (red, red) into the Fan Relay Contacts. Connect the green wire into the chassis ground lug.
- In the blower module hard wire the harness wires (red, red, green) as per Section 7.3 Blower Box Wiring Connections in this manual.

Thermostat 24V Control Wiring:

- Connect a single pair of 24V control wire (not supplied) to the #4 and #7 terminals on the terminal strip mounted to the top of the main control box of the wood furnace.
- Route and secure the control wire around the back of the wood furnace and under the bottom of the electric furnace module. Pass the control wire through a plastic grommet (not supplied) through the bottom knockout of the electric furnace control box.
- Connect the 24V control wire to terminals "C" and "1" on the electric furnace control board.

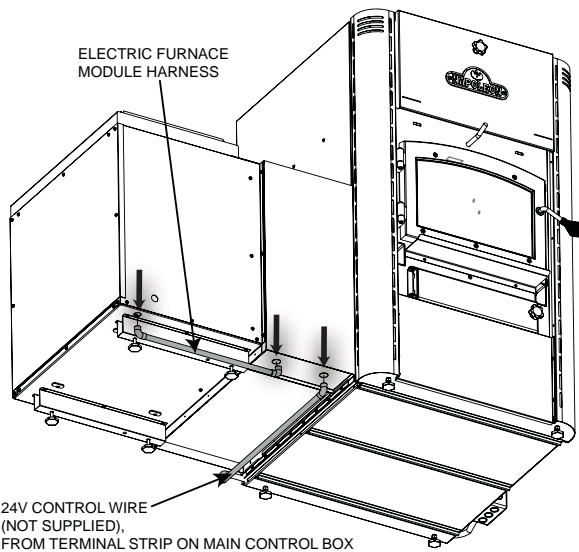

WIRE ROUTING AND TERMINATION IN ELECTRIC FURNACE CONTROL BOX

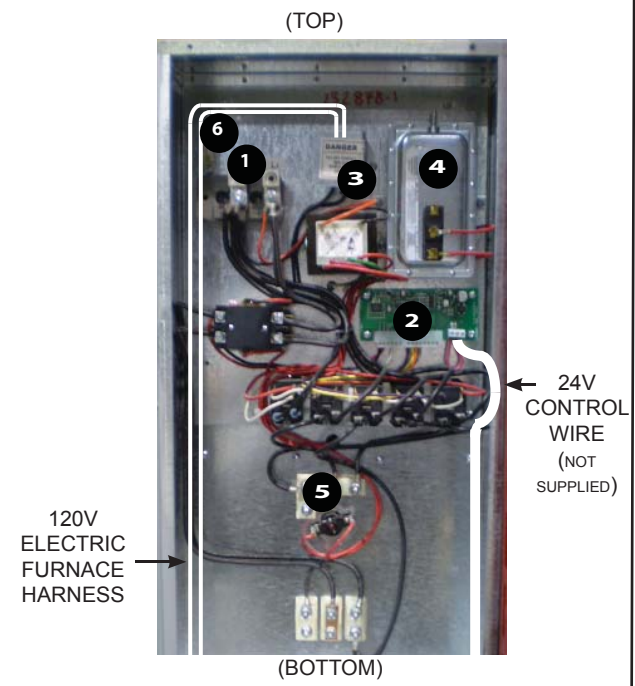

LEGEND

1. HEATER ELEMENT POWER TERMINALS
2. ELECTRIC FURNACE CONTROL BOARD
3. FAN RELAY CONTACTS
4. "BLOWER ON" PRESSURE SENSOR
5. MANUAL RESET
6. CHASSIS GROUND LUG - ATTACH ALL ELECTRIC HARNESS GROUNDS.

⚠ WARNING

KEEP CONTROL WIRE AWAY FROM HOT SPOTS ON FURNACE THAT WILL DAMAGE WIRE.

STEP #14

- See SECTION 8.0 - OPERATING INSTRUCTIONS.

5.5 HYBRID HMF150/200 AS A “WOOD/OIL/ELECTRIC” FURNACE

REQUIRED COMPONENTS:

- HMF150/200 Hybrid Furnace
- HMFK-BMP50 Blower Box Module
- HMFK-EF15, -EF18, -EF20, -EF25 Electric Furnace Module (*HMFK-EF15 for the HMF150 only, and HMFK-EF25 for HMF200 only*)
- HMFK-OFRF40 or HMFK-OFBNX Oil Burner Module
- HMFK-CMBCH-1 (HMF150) or HMFK-CCH200 (HMF200) Oil Combustion/Heat Exchanger
- HMFK-WMO WMO Thermal Safety Switch
- HMFK-SOLID or HMFK-GLASS Door Kit

STEPS #1 - #7

Follow Steps 1 to 7 from SECTION 5.4 - HYBRID HMF150/200 AS A “COMBINATION WOOD/ELECTRIC” FURNACE.

STEPS #8 - #19

Follow Steps 2 to 12 from SECTION 5.3 - HYBRID HMF150/200 AS A “COMBINATION WOOD/OIL” FURNACE.

STEPS #20

See SECTION 6.0 - PLENUM AND VENTING INSTALLATION.

STEPS #21

See SECTION 7.0 - ELECTRICAL CONNECTIONS AND SCHEMATICS.

STEPS #22

See SECTION 8.0 - OPERATING INSTRUCTIONS.

6.0 PLENUM AND VENTING INSTALLATION/ CLEARANCE TO COMBUSTIBLE MATERIALS

 WARNING
ALL PLENUM DUCTING AND VENTING INSTALLATION MUST CONFORM WITH CAN/CSA B365-01, CSA B139-09, AND NFPA 211. ALWAYS CHECK LOCAL BUILDING AND FIRE CODES , AND AUTHORITIES HAVING JURISDICTION.
ALL PLENUM, DUCTING AND VENTING MUST BE INSTALLED BY A QUALIFIED INSTALLER.
DO NOT USE MAKESHIFT COMPROMISES DURING INSTALLATION. DO NOT BLOCK OR RESTRICT AIR. (DO NOT IMPEDE AIR MOVEMENT IN ZONES MARKED "CLEARANCE TO COMBUSTIBLES".)
MINIMUM CLEARANCE TO COMBUSTIBLE DIMENSIONS MUST BE ADHERED TO.
MINIMUM CLEARANCE FLOOR TO CEILING; C/HMF150 6FT 3IN (1.9M), C/HMF200 7FT (2.1M)

H3.53A

6.1 FLUE / CHIMNEY FOR HMF150/200 IN CONFIGURATIONS:

- stand alone wood furnace
- combination wood/electric furnace
- combination wood/oil furnace
- combination wood/electric/oil furnace

See Section 6.4 for flue configuration on a "Add On" furnace configuration.

 WARNING
DO NOT CONNECT THIS UNIT TO A CHIMNEY FLUE SERVING ANOTHER APPLIANCE!!
THE WOOD FURNACE SECTION CAN OPERATE USING A 6" (152mm) DIAMETER FLUE PIPE, BUT WE RECOMMEND THAT THE FLUE SIZE BE A 7" (178mm) DIAMETER WHERE THE FURNACE IS TO BE SET UP AS (OR IN CONSIDERATION TO A FUTURE RETRO FIT TO A WOOD/OIL OR WOOD/OIL/ ELECTRIC COMBINATION.
USE CHIMNEY CERTIFIED TO 2100°F (1149°C) FOR WOOD BURNING APPLIANCES, LISTED AS UL103HT(USA), ULCS629 (CANADA) MINIMUM 6" (152mm) DIAMETER LISTED RESIDENTIAL CHIMNEY. SEE AND FOLLOW CHIMNEY MANUFACTURES INSTRUCTIONS.
THE FURNACE CAN ALSO BE CONNECTED TO A MASONRY CONSTRUCTED CHIMNEY IN COMPLIANCE WITH LOCAL BUILDING CODES. THE MASONRY CHIMNEY MUST BE FULLY LINED WITH 8" X 8" (203mm X 203mm) SQUARE VITRIFIED CLAY TILES OR WITH A STAINLESS STEEL LINER CONFORMING WITH ULC-5640M (CANADA) OR UL-1777 (USA). THE CHIMNEY OR CHIMNEY LINER MUST BE CONNECTED TO THE APPLIANCE USING AN APPROVED VENT CONNECTOR SYSTEM (STOVE PIPE IS SUITABLE PROVIDED APPROPRIATE CLEARANCES ARE MAINTAINED).
CHIMNEY DRAFT GREATER THAN -0.06" W.C. (-15 Pa) MAY CAUSE AN UNCONTROLLABLE FIRE AND DAMAGE THE FURNACE.
ALL PLENUM DUCTING AND VENTING INSTALLATION MUST CONFORM WITH CAN/CSA B365-10, CSA B139-09, AND NFPA 211. ALWAYS CHECK LOCAL BUILDING AND FIRE CODES, AND AUTHORITIES HAVING JURISDICTION.

H3.54A

6.1.1 CONTROLLING DRAFT

- Use of inclined manual dampers is forbidden.
- Barometric dampers shall not be used for any wood furnace venting other than wood/oil combination which share a common chimney. In this case, the barometric damper should be installed to maintain an operating draft between -0.04" and -0.06" W.C. (-10 Pa and -15 Pa), when operating the wood furnace.

! WARNING

THE USE OF A BAROMETRIC DAMPER ON A WOOD OR WOOD/OIL APPLIANCE CAN HAVE THE FOLLOWING CONSEQUENCES:

1. DILLUTION AIR ENTERING THROUGH THE BAROMETRIC DAMPER MAY PREMATURELY COOL EXHAUST PRODUCTS CREATING EXCESS CREOSOTE DEPOSITS INSIDE THE CHIMNEY LEADING TO A CHIMNEY FIRE HAZARD.
2. IF A CHIMNEY FIRE OCCURS, THE BYPASS DAMPER CAN PULL OPEN UNDER DRAFT PRESSURE AND FORCE FEED AND INTENSIFY THE FIRE. STAY VIGILANT FOR RAPIDLY DEPOSITING CREOSOTE WHEN RUNNING A VENT SYSTEM WITH A BAROMETRIC DAMPER.

H3.78

6.2 VENTING CONFIGURATION FOR WOOD/OIL COMBINATION FURNACE

VENTING CONFIGURATION FOR BRINGING SEPARATE WOOD AND OIL FURNACE FLUES INTO A COMMON VENT

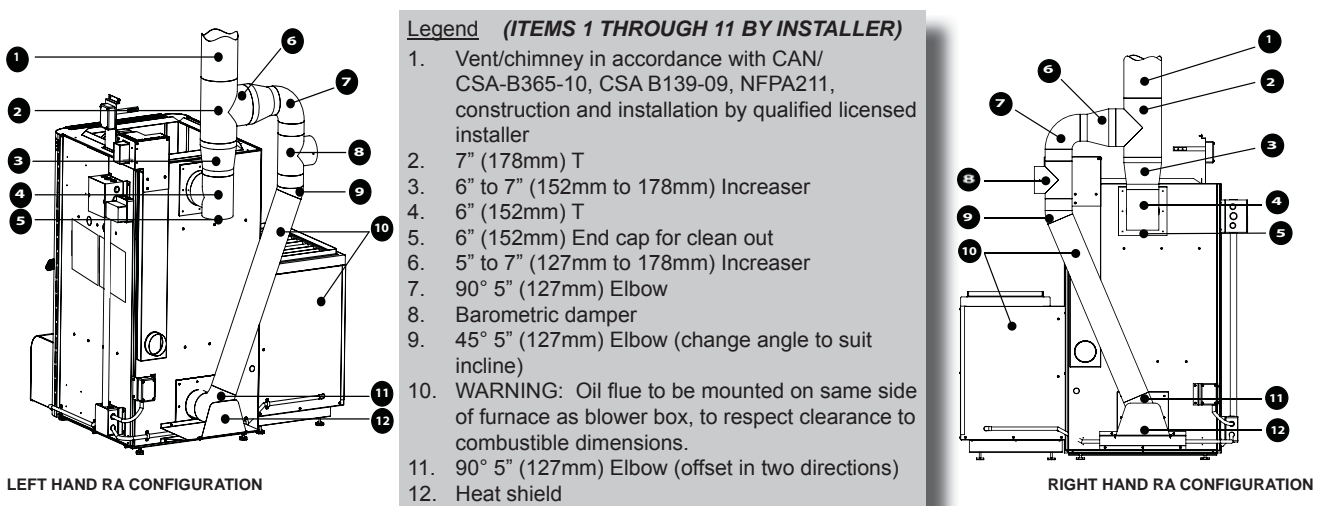

NOTE

Connection of solid fuel and oil fired appliances to a common chimney, see Section 5.1.4 of CSA B139-09 and Section 5.2.7 of CAN/CSA B365-10 for conditions allowing a single chimney for wood and oil. Common chimney must be approved for use with woodburning appliances (2100°F) (1149°C).

! WARNING

STRICTLY ADHERE TO ALL IDENTIFIED INSTALLATION CLEARANCES.

H3.55

VENTING CLEARANCE TO COMBUSTIBLES AND SERVICE CLEARANCES

EN

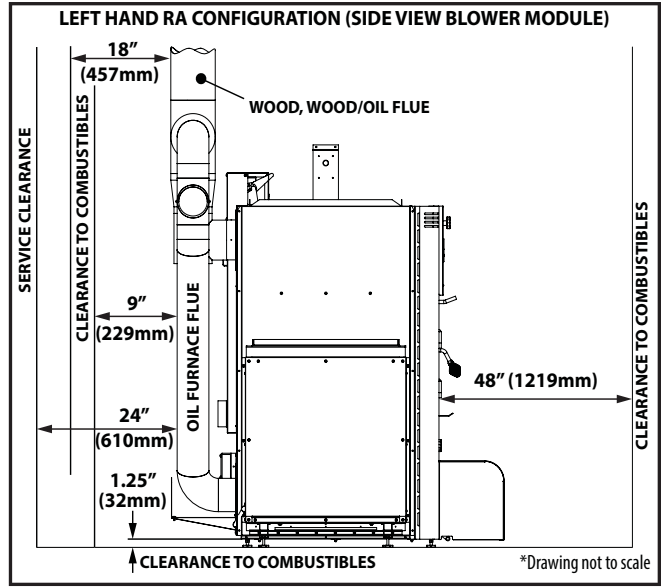
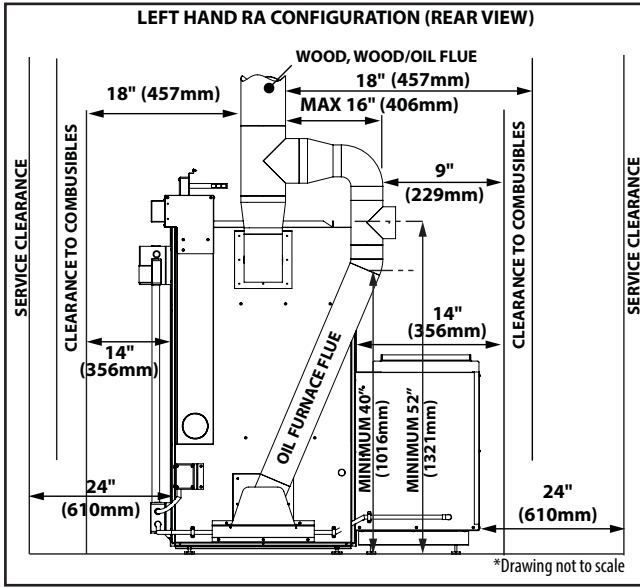

⚠ WARNING

VENTING FROM OIL FLUE ALWAYS INCLINES TO THE SAME SIDE OF THE FURNACE THAT THE BLOWER MODULE IS MOUNTED ON.

H3.56

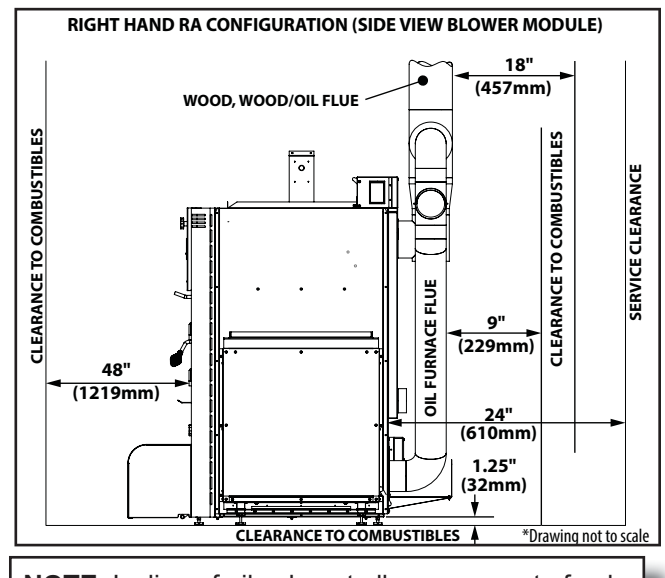
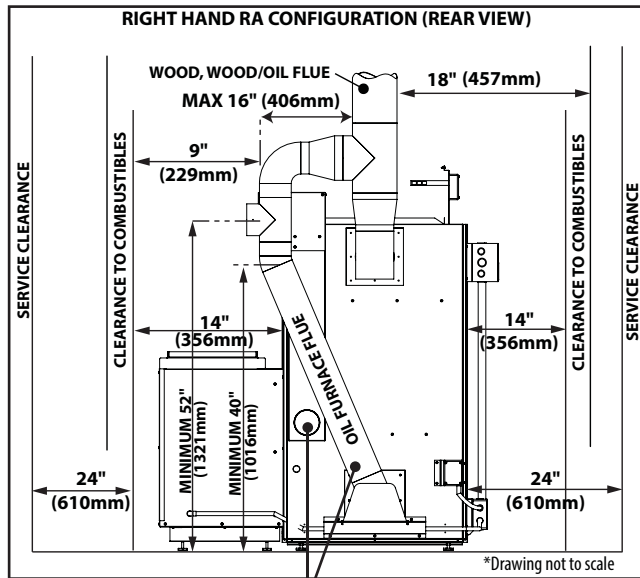

NOTE: Incline of oil exhaust allows access to fresh air inlet.

6.3 GENERAL PLENUM AND DUCTING - MINIMUM CLEARANCE TO COMBUSTIBLES

All plenum and ducting clearances must satisfy specification set forth in CAN/CSA-B365-10 and NFPA211.

CLEARANCE TO COMBUSTIBLES	SECTION		
	A	B	C
TOP	6" (152mm) *	6" (152mm)	1" (25mm)
BOTTOM/ SIDES	18" (457mm)	6" (152mm)	1" (25mm)

IMPORTANT:

Minimum ceiling heights required: • HMF150 6ft 3in (1.9m)
• HMF200 7ft (2.13m)

* **FOR HMF150 ONLY.** Clearance can be reduced from 6" (152mm) to a minimum of 3" (76mm), providing that shielding with the following specifications is employed. Ceiling height can be reduced to 6ft. (1.8m) when shielding specifications are met.

* **FOR HMF200 ONLY.** Minimum ceiling height for installation can be reduced to 6' 9" (2.06m) provided shielding specifications in Section 6.3.2 are employed and a clearance of 6" (152mm) is maintained between the top surface of the plenum and initial 6ft. (1.8m) of duct run.

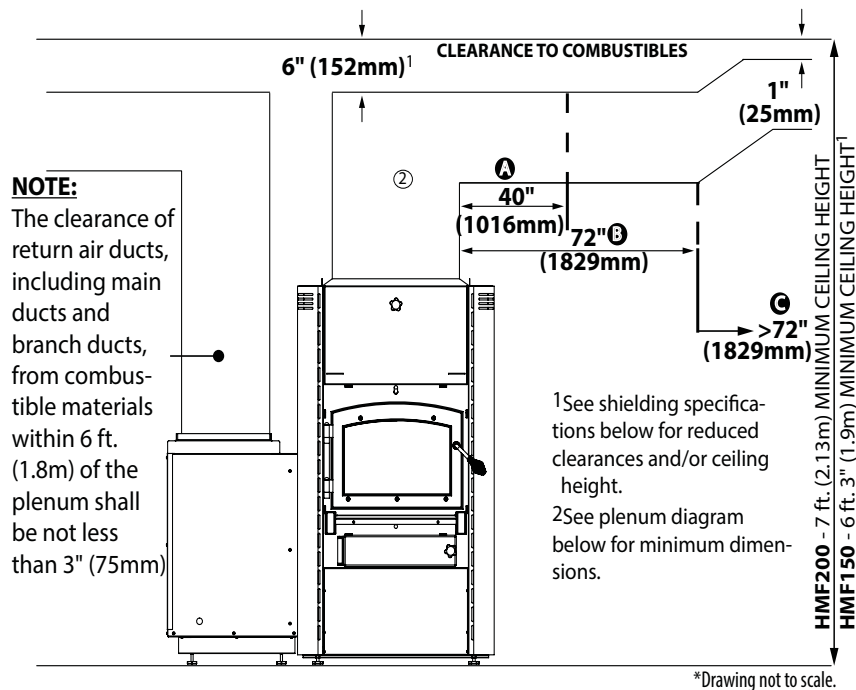

6.3.1 HMF150 SHIELDING SPECIFICATIONS

- Shield must be constructed of sheet metal with a minimum thickness of 26 gauge.
- Shield to be spaced out from combustible surface between 7/8" (22mm) and 1" (25mm), using non-combustible spacers (air gap between combustible surface and shield must be maintained).
- Shield dimensions and locations must protect the area illustrated in the diagram below.

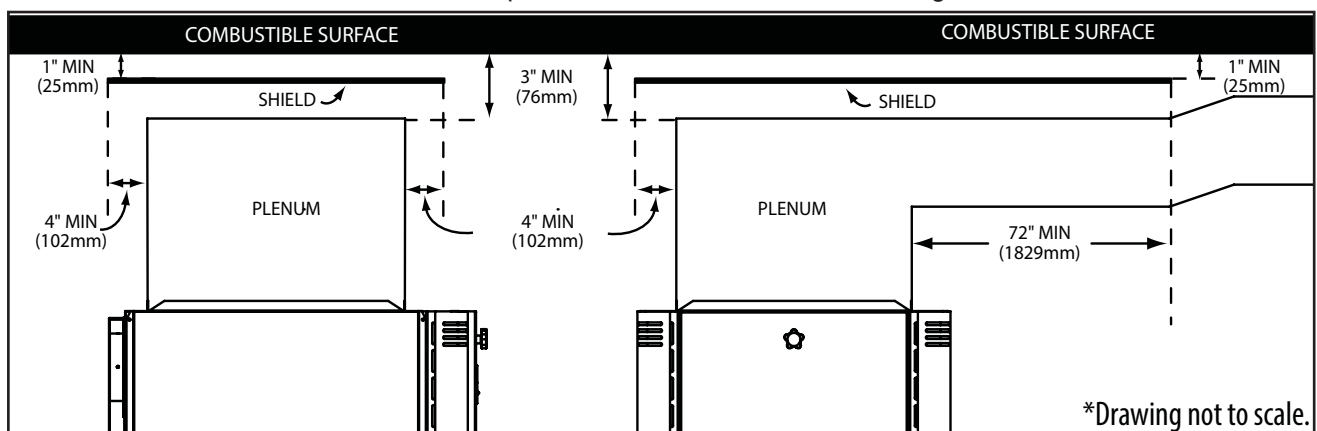

6.3.2 HMF200 SHIELDING SPECIFICATIONS

- Shield must be constructed of sheet metal with a minimum thickness of 26 gauge.
- Shield to be spaced out from combustible surface a minimum of 1" (25mm), using non-combustible spacers (air gap between combustible surface and shield must be maintained).
- Maintain a minimum gap of 6" (152mm) between the top surface of the plenum and initial 6ft. (1.8m) of duct run.
- Shield dimensions and locations must protect the area illustrated in the diagram below.

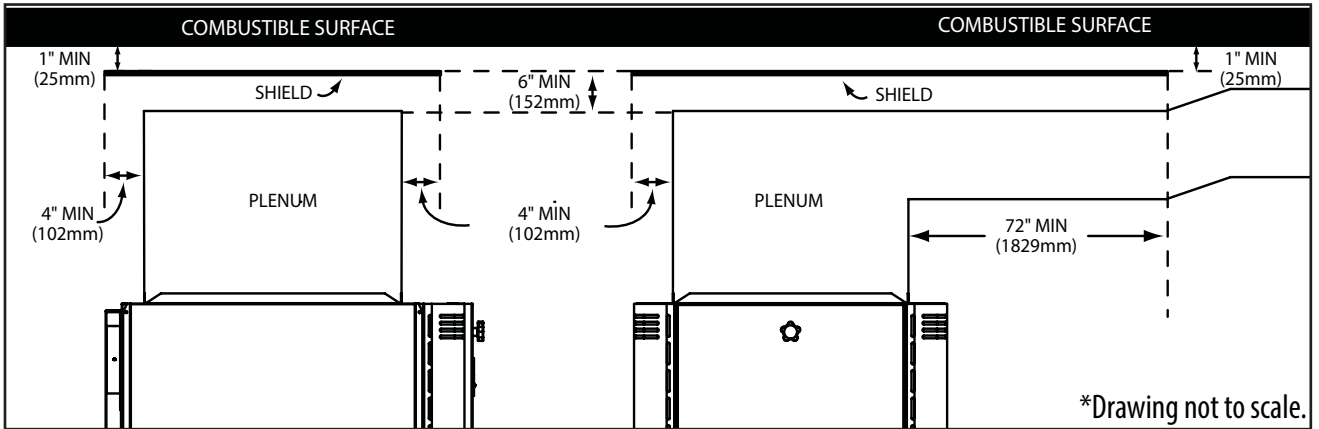

MINIMUM SUPPLY PLENUM AND HORIZONTAL DUCT HEIGHTS

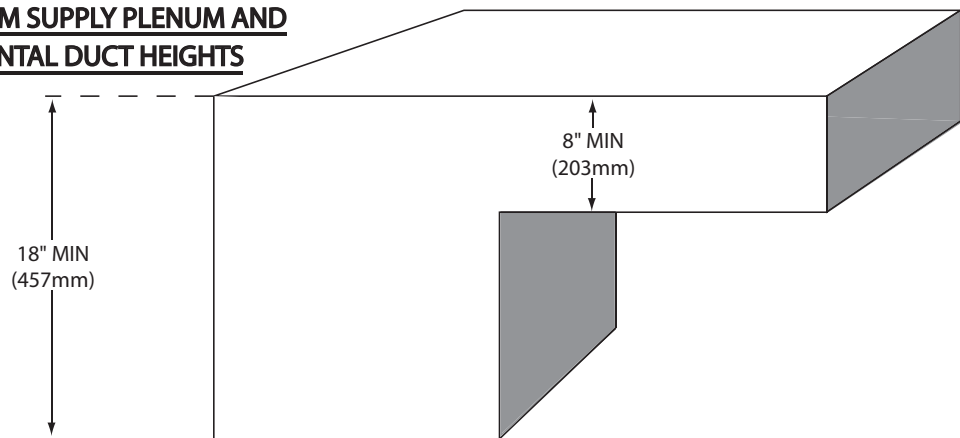

6.4 FLUE CONFIGURATION FOR "ADD ON" FURNACE CONFIGURATION

Separate chimneys are required when connecting the HMF150/200 to a natural gas or propane furnace.

 WARNING
UNDER NO CONDITIONS MAY A SOLID FUEL BURNING APPLIANCE SHARE A CHIMNEY THAT VENTS NATURAL GAS OR PROPANE EXHAUST.
DO NOT USE MAKESHIFT COMPROMISES DURING INSTALLATION. DO NOT BLOCK OR RESTRICT AIR. DO NOT IMPEDE AIR MOVEMENT ZONES MARKED "CLEARANCE TO COMBUSTIBLES".
ALL PLENUM DUCTING AND VENTING INSTALLATION MUST CONFORM WITH CAN/CSA B365-10, CSA B139-09, AND NFPA 211. ALWAYS CHECK LOCAL BUILDING AND FIRE CODES , AND AUTHORITIES HAVING JURISDICTION.
THE WOOD FURNACE SECTION CAN OPERATE USING A MINIMUM 6" (152mm) FLUE PIPE, BUT WE RECOMMEND THAT THE FLUE SIZE BE SET AT A MINIMUM OF 7" (178mm) DIAMETER WHERE THE FURNACE IS TO BE SET UP AS (OR IN CONSIDERATION TO A FUTURE RETRO FIT TO A WOOD/OIL OR WOOD/OIL/ELECTRIC COMBINATION.
USE CHIMNEY CERTIFIED TO 2100°F (1149°C) FOR WOOD BURNING APPLIANCES, LISTED AS UL103HT(USA), ULCS629 (CANADA) MINIMUM 6" (152mm) DIAMETER LISTED RESIDENTIAL CHIMNEY. SEE AND FOLLOW CHIMNEY MANUFACTURES INSTRUCTIONS.
THE FURNACE CAN ALSO BE CONNECTED TO A MASONRY CONSTRUCTED CHIMNEY IN COMPLIANCE WITH LOCAL BUILDING CODES. THE MASONRY CHIMNEY MUST BE FULLY LINED WITH 8" X 8" (203mm X 203mm) SQUARE VITRIFIED CLAY TILES OR WITH A STAINLESS STEEL LINER CONFORMING WITH ULC-5640M (CANADA) OR UL-1777 (USA). THE CHIMNEY OR CHIMNEY LINER MUST BE CONNECTED TO THE APPLIANCE USING AN APPROVED VENT CONNECTOR SYSTEM (STOVE PIPE IS SUITABLE PROVIDED APPROPRIATE CLEARANCES ARE MAINTAINED).
CHIMNEY DRAFT GREATER THAN -0.06" W.C. (-15 Pa) MAY CAUSE AN UNCONTROLLABLE FIRE AND DAMAGE THE FURNACE.

H3.57A

Separate chimneys are recommended when connecting the HMF150/200 to a pre existing oil furnace. If a single chimney is used in this application it must be 7" (178mm) in diameter and approved for use with wood burning appliances (2100°F) (1149°C), UL103HT (US), ULC S629 (Canada).

- The exhaust pipe from the wood flue must connect to the chimney below the junction of the oil exhaust to the common chimney.

6.4.1 CONTROLLING DRAFT

- Use of inclined manual dampers is forbidden.
- Barometric dampers shall not be used for any wood furnace venting other than wood/oil combination which share a common chimney. In this case, the barometric damper should be installed to maintain an operating draft between -0.04" and -0.06" W.C. (-10 Pa and -15 Pa), when operating the wood furnace.

 WARNING
THE USE OF A BAROMETRIC DAMPER ON A WOOD OR WOOD/OIL APPLIANCE CAN HAVE THE FOLLOWING CONSEQUENCES:
<ol style="list-style-type: none"> 1. DILLUTION AIR ENTERING THROUGH THE BAROMETRIC DAMPER MAY PREMATURELY COOL EXHAUST PRODUCTS CREATING EXCESS CREOSOTE DEPOSITS INSIDE THE CHIMNEY LEADING TO A CHIMNEY FIRE HAZARD. 2. IF A CHIMNEY FIRE OCCURS, THE BYPASS DAMPER CAN PULL OPEN UNDER DRAFT PRESSURE AND FORCE FEED AND INTENSIFY THE FIRE. STAY VIGILANT FOR RAPIDLY DEPOSITING CREOSOTE WHEN RUNNING A VENT SYSTEM WITH A BAROMETRIC DAMPER.

H3.78

6.4.2 MEASURING DRAFT

Using a manometer with appropriate scale range connect testing tube between manometer and chimney connector. End of testing tube should be inserted in chimney connector so approximately 1" (25mm) of tube protrudes into and perpendicular to exhaust stream. This measurement shall be taken approximately 12" (305mm) above elbow/T attached to the furnace flue. Any hole made in the chimney connector for insertion of manometer tube shall be adequately sealed with high temp materials when testing is complete.

WARNING

CHIMNEY DRAFT GREATER THAN -0.06" W.C. (-15 Pa) MAY CAUSE AN UNCONTROLLABLE FIRE AND DAMAGE THE FURNACE.

H3.58

6.5 CONNECTING DUCTWORK/PLENUMS BETWEEN "ADD ON" FURNACE AND ORIGINAL FURNACE

IMPORTANT:

- The warm air supply duct system shall be constructed of metal in accordance with NFPA 90B, 2-1.1.
- The plenums installed to the furnace shall be constructed of metal in accordance with NFPA 90B, 2-1.3.

WARNING

USE EXTREME CAUTION WHEN BUILDING PLENUM/DUCT WORK SYSTEMS SO AS NOT TO CREATE A CONDITION WHERE HOT AIR CAN BE ENTRAPPED IN DUCT WORK, OR CREATING A REVERSE FLOW CONDITION. WHERE HOT AIR WOULD FLOW BACKWARDS INTO THE COLD AIR RETURN PLENUM AND DUCTING.

NEVER CONNECT THE WARM AIR SUPPLY OUTLET OF THE "ADD ON" FURNACE TO THE COLD AIR SUPPLY OF THE CENTRAL (ORIGINAL) FURNACE. FAILURE TO COMPLY MAY RESULT IN DAMAGE TO PROPERTY AND CREATE A FIRE HAZARD.

FOR MORE INFORMATION ON ALLOWABLE/PROHIBITED METHODS OF CONNECTING "ADD ON" FURNACES TO A PRE EXISTING FURNACE SEE FIGURES 1 THROUGH 7 OF CAN/CSA-B366.1-M91.

H3.59

SAMPLES OF ALLOWABLE PLENUM/DUCTING ARRANGEMENTS

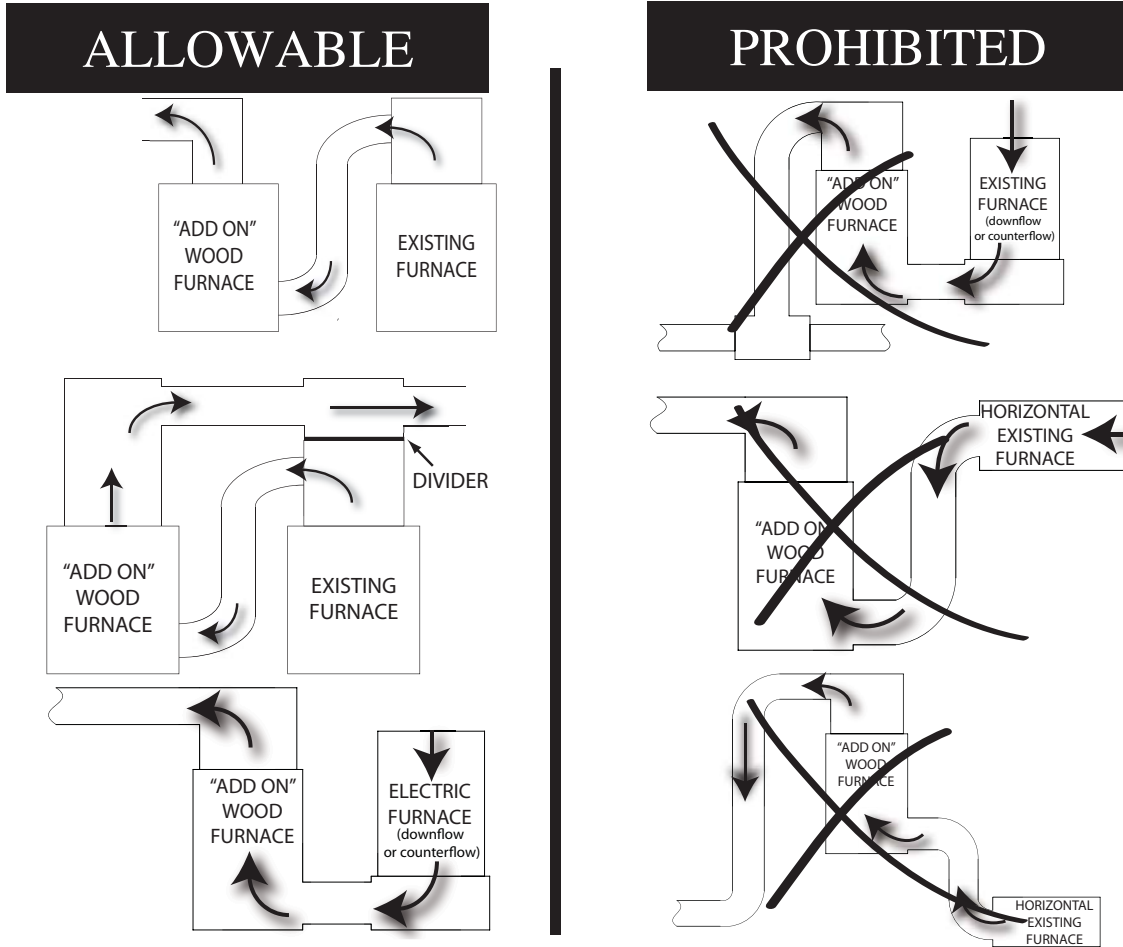

6.6 EMBER STOP

- For installations on combustible flooring an ember stop protective floor covering must be installed.
- An ember stop of minimum 0.015" (0.4mm) thick sheet steel extending 18" (457mm) in front of firebox door to 2" (76mm) behind the cleanout of the chimney. The ember stop width must protrude a minimum of 8" (203mm) from both sides of the furnace.
- Carpet or other floor covering shall be removed before placement of ember stop sheet.
- Refer to Section 7.1 of CAN/CSA-B365-10 for complete details of floor protection.

EMBER STOP: SIDE DIMENSIONS

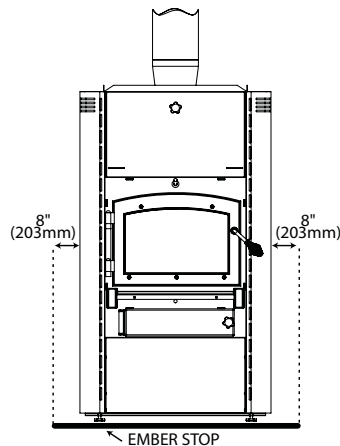

EMBER STOP: FRONT AND REAR DIMENSIONS

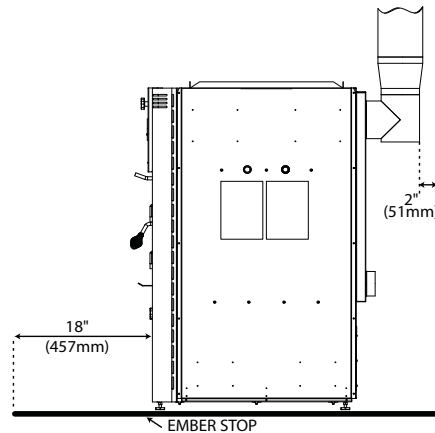

6.7 CONNECTING A HMF FURNACE SYSTEM TO AIR CONDITIONING

SUGGESTED KIT

HMFK-AC1 • Contains limit switches and damper position/warning labels for interlocking plenum damper controls to wood furnace combustion air controls.

REQUIRED KIT

HMFK-AC2 • Contains field install relay blocks and wiring required when using HMFK-BMP50(-1) Blower Module in combination with central air.

EN

 **WARNING**

ONLY USE A BYPASS PLENUM ARRANGEMENT WHEN CONNECTING AIR CONDITIONING TO A CHMF/HMF 150/200 FURNACE SYSTEM. OTHER ARRANGEMENTS MAY CAUSE REDUCED AIR FLOW IN DUCTWORK WHICH MAY CAUSE FURNACE AND AIR CONDITIONING EQUIPMENT TO OPERATE OUTSIDE THEIR SAFE OPERATING PARAMETERS. FURNACE AND DUCTING SYSTEMS COULD DEVELOP EXCESSIVE SURFACE TEMPERATURES INCREASING THE RISK OF FIRE, RESULTING IN EQUIPMENT DAMAGE, PROPERTY DAMAGE, AND PERSONAL INJURY INCLUDING DEATH.

ALL SEASONAL DUCTING DAMPERS MUST BE CORRECTLY ORIENTED FOR THE APPROPRIATE MODE OF OPERATION (FURNACE OR AIR CONDITIONING). FAILURE TO CORRECTLY POSITION THE SEASONAL DUCTING DAMPERS WILL CAUSE FURNACE AND AIR CONDITIONING EQUIPMENT TO OPERATE OUTSIDE THEIR SAFE OPERATING PARAMETERS. FURNACE AND DUCTING SYSTEMS COULD DEVELOP EXCESSIVE SURFACE TEMPERATURES INCREASING THE RISK OF FIRE, RESULTING IN EQUIPMENT DAMAGE, PROPERTY DAMAGE, AND PERSONAL INJURY INCLUDING DEATH.

H3.60

 **WARNING**

DO NOT USE “FAN SUMMER SWITCH (ON MODE)”, “OVERRIDE SWITCHES (MANUAL POSITION)”, “CONTINUOUS FAN OPERATION ON BACK UP FURNACE (IN “ADD ON” CONFIGURATION)”, WHEN OPERATING THE WOOD FURNACE.

DO NOT CONNECT HRV’S SO THEY ARE CONTROLLING THE CYCLING OF THE FURNACE CIRCULATION BLOWER.

FAILURE TO COMPLY WITH THIS WILL RESULT IN EXCESSIVE COOLING OF THE EXHAUST PRODUCTS AS THEY PASS THROUGH THE EXCHANGER PIPES, THE FURNACE FLUE AND THE CHIMNEY SYSTEM. THIS COOLING WILL RESULT IN THE CONDENSATION OF EXHAUST PRODUCTS IN THE EXCHANGER AND CHIMNEY RESULTING IN EXCESSIVE CREOSOTE BUILD UP. THE CREOSOTE BUILD UP WILL RESULT IN REDUCED EFFICIENCIES OF THE EXCHANGER TUBES AND MAY CAUSE A CHIMNEY FIRE.

H3.65A

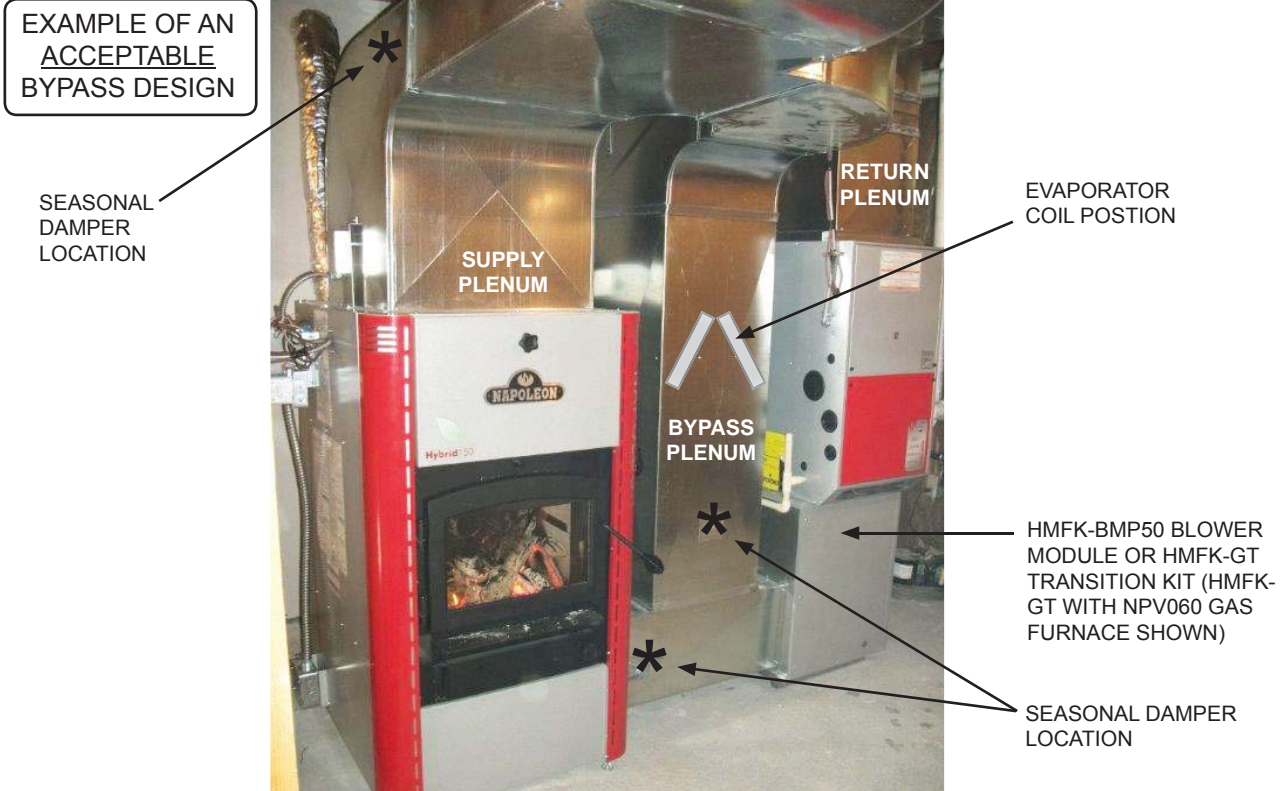

6.7.1 SEASONAL DAMPER POSITIONS

DAMPER ORIENTATION “WINTER MODE”



All three dampers are in the horizontal position blocking air flow through the bypass plenum and forcing air through the furnace loop.

DAMPER ORIENTATION “SUMMER MODE”



All three dampers are in the vertical position blocking air flow on both the return and the supply ends of the wood furnace, forcing air flow through the air conditioning evaporator coil.

6.7.2 DIMENSIONAL CONSIDERATIONS FOR BYPASS DUCT

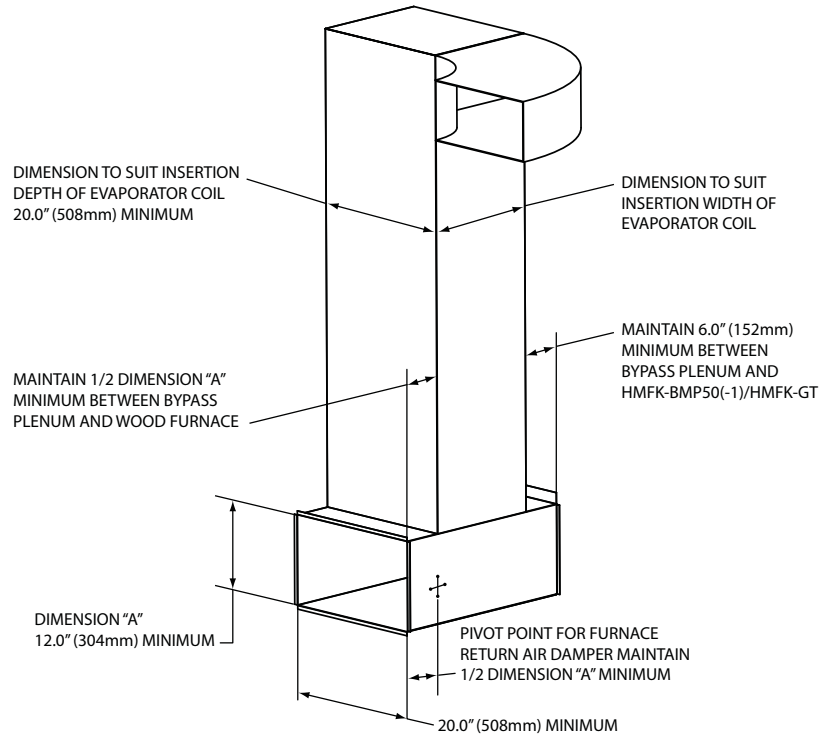

6.7.3 INTERLOCKING DAMPER POSITIONS TO THE PRIMARY AIR CONTROL OF THE WOOD FURNACE

A circuit can be created that will prevent the wood furnace from going to high fire if the seasonal dampers are not in the winter heating position.

Start by mounting the mechanical limit switches in such a manner that the actuator handles of the seasonal dampers come into contact with the actuator mechanism of the limit switch.

This action should cause the contacts of the switches to close when the dampers are fully in the winter heating position.

By connecting the three mechanical limit switches in series with the low voltage control circuit (which contains the air damper motor), the air damper will not open (required to bring furnace to high fire operation) if any of the three limit switches have not been closed.

The control circuit that requires the limit switches runs between terminals #10 and #11 of the control terminal strip mounted on the wood furnace control box.

NOTE

Accessory Kit HMFK-AC1 contains mechanical limit switches and mounting brackets suitable for this circuit.

Example shows part of the control wiring for wood, wood/electric, wood/oil, or wood/oil electric with air conditioning configurations.

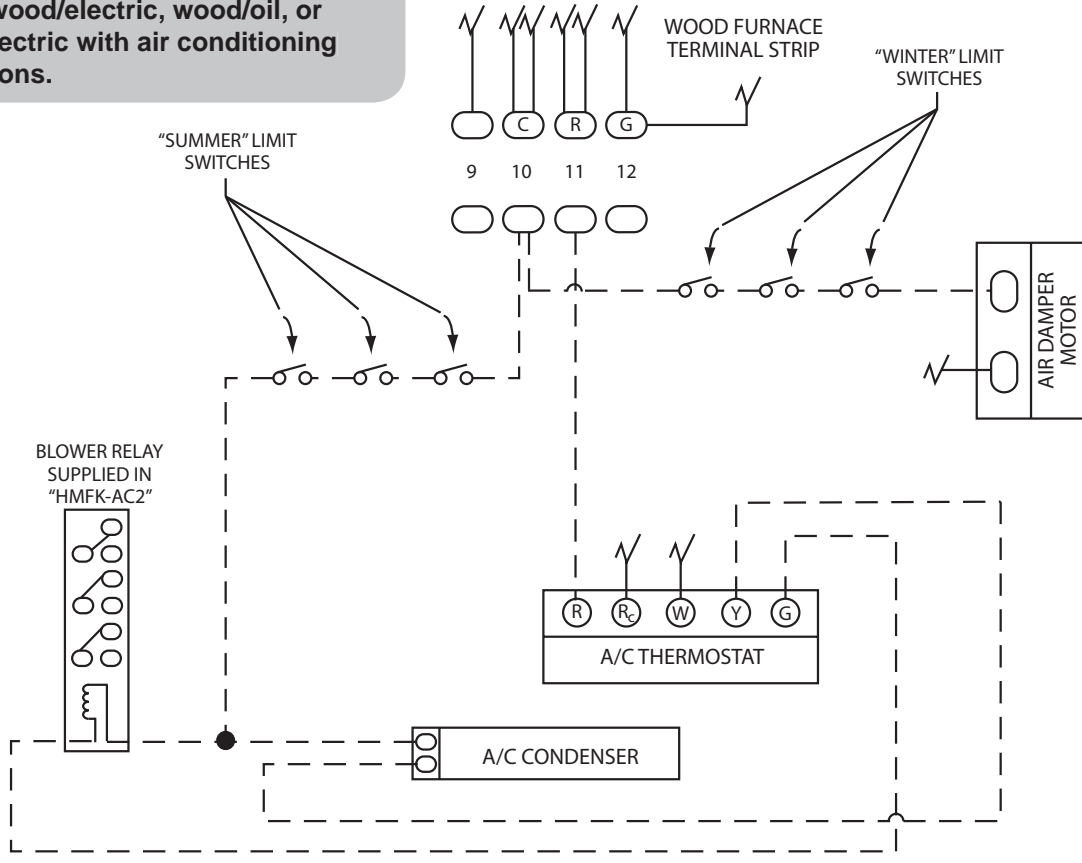

H73.1

Example shows part of the control wiring for wood “add on” with air conditioning configuration.

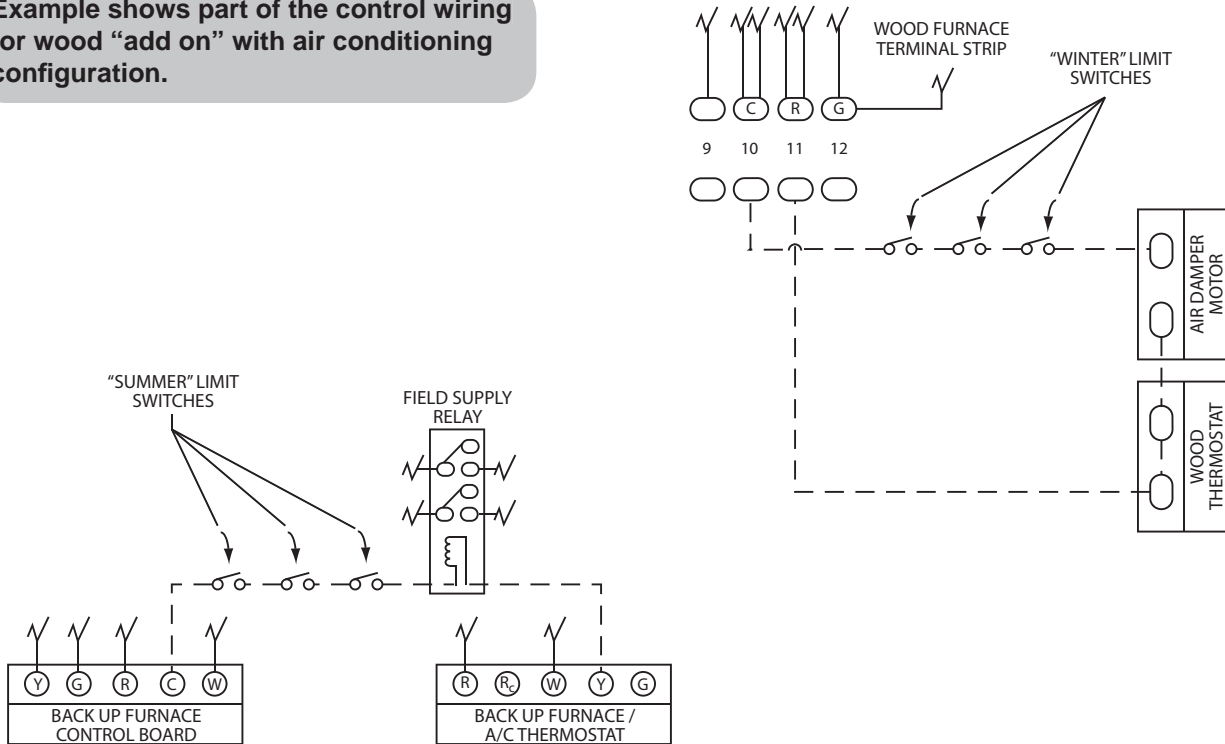

H73.2

7.0 ELECTRICAL CONNECTIONS AND SCHEMATICS

 WARNING
ALL ELECTRICAL WIRING AND CONNECTIONS MUST BE DONE BY A QUALIFIED ELECTRICIAN. THE ELECTRICAL INSTALLATION MUST SATISFY ALL RELEVANT ASPECTS OF CSA 22.1 AND IN PARTICULAR CAN/CSA-222.2 NO.0-M91, NO.3-M1988, NO. 23.1-M1986.
ALL WIRING BRINGING 120V OR GREATER TO THE HMF150 AND ITS MODULES, SHALL BE AS SPECIFIED IN ELECTRICAL CODE BUT MUST HAVE WIRE INSULATION VALUE OF NO LESS THAN 90°C.
MUST MAINTAIN A MINIMUM CLEARANCE OF 12" (305mm) BETWEEN ELECTRIC WIRING CARRYING 120V OR GREATER AND ALL SURFACES OF THE SUPPLY PLENUM AND DUCT WORK.
MAINTAIN MINIMUM 18" (457mm) CLEARANCE BETWEEN ALL FURNACE EXHAUST COMPONENTS AND ELECTRICAL WIRING CARRYING 120V OR GREATER.

H3.61

7.1 LOW VOLTAGE WIRING - THERMOSTAT

The thermostat and control wiring should be a minimum of 18 AWG copper. Excessive lengths of wire may result in enough voltage drop to impair the proper functioning of the furnace. For thermostat wires in excess of 25 feet (7.6m), use 16 AWG; 50 feet (15.2m), use 14 AWG.

H53.1

7.2 THERMOSTAT LOCATION

The thermostat should be located approximately 5 feet (1524mm) above the floor, on an inside wall where there is good natural air circulation, and where the thermostat will be exposed to average room temperatures. Avoid locations where the thermostat will be exposed to cold drafts, heat from nearby lamps or appliances, exposure to sunlight, heat from inside wall stacks, etc.

H53.2

7.3 BLOWER BOX WIRING CONNECTIONS

STEP #1

- Pass wiring through the liquid tight connector on the side of the electrical box, and connect the wire ends as per the following wiring schematic.

STEP #2

- Fasten cover to the electrical box.
- Tighten liquid tight connector.

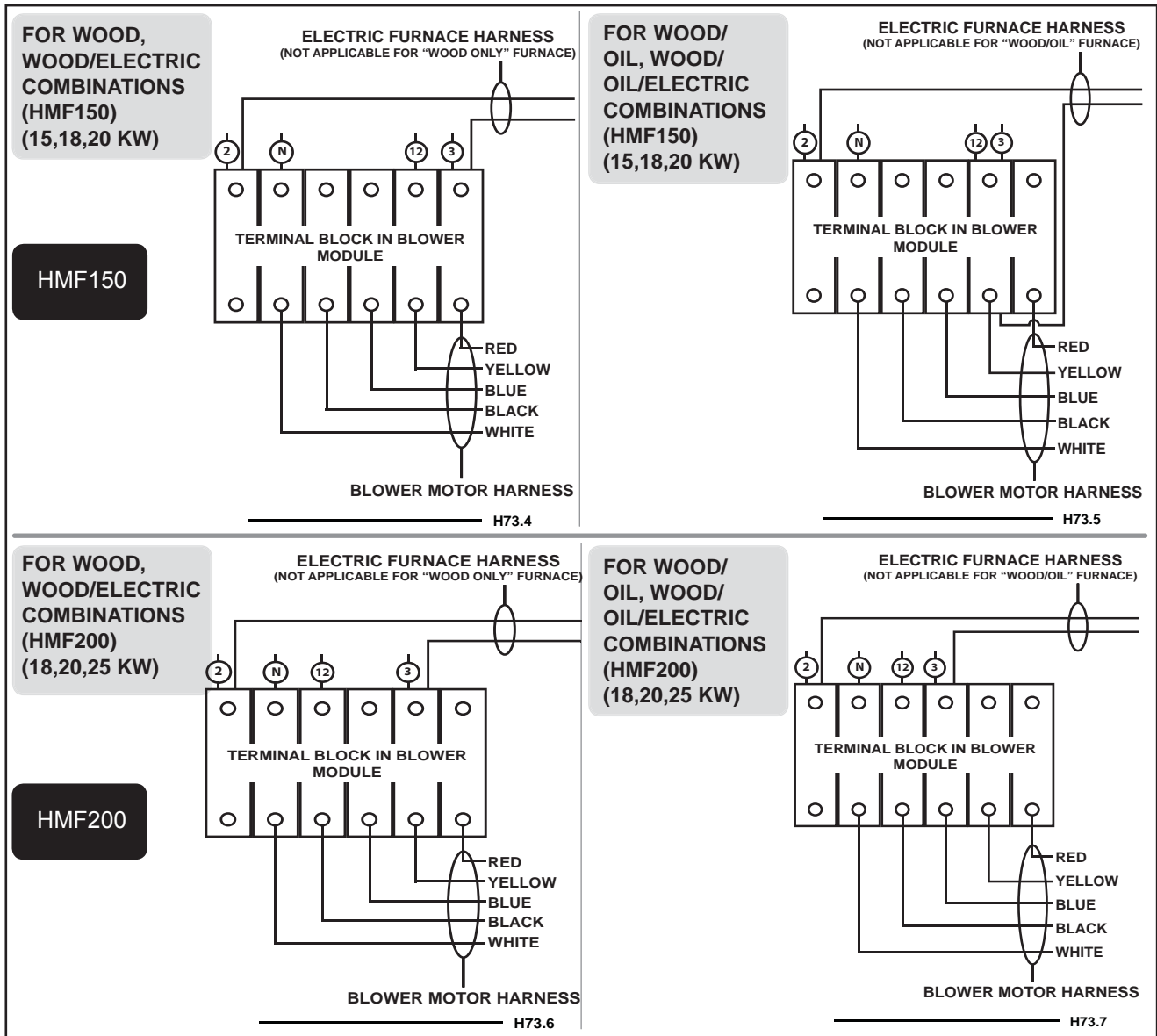

7.3.1 SELECTING AIR CONDITIONING BLOWER SPEEDS

NOTE

See air conditioner manufacturers specification for required air flow for given coil sizes. If specification not available, use 400 CFM for every ton of cooling, as a general rule.

AIR SPEEDS AVAILABLE WITH HMFK-BMP50-1:

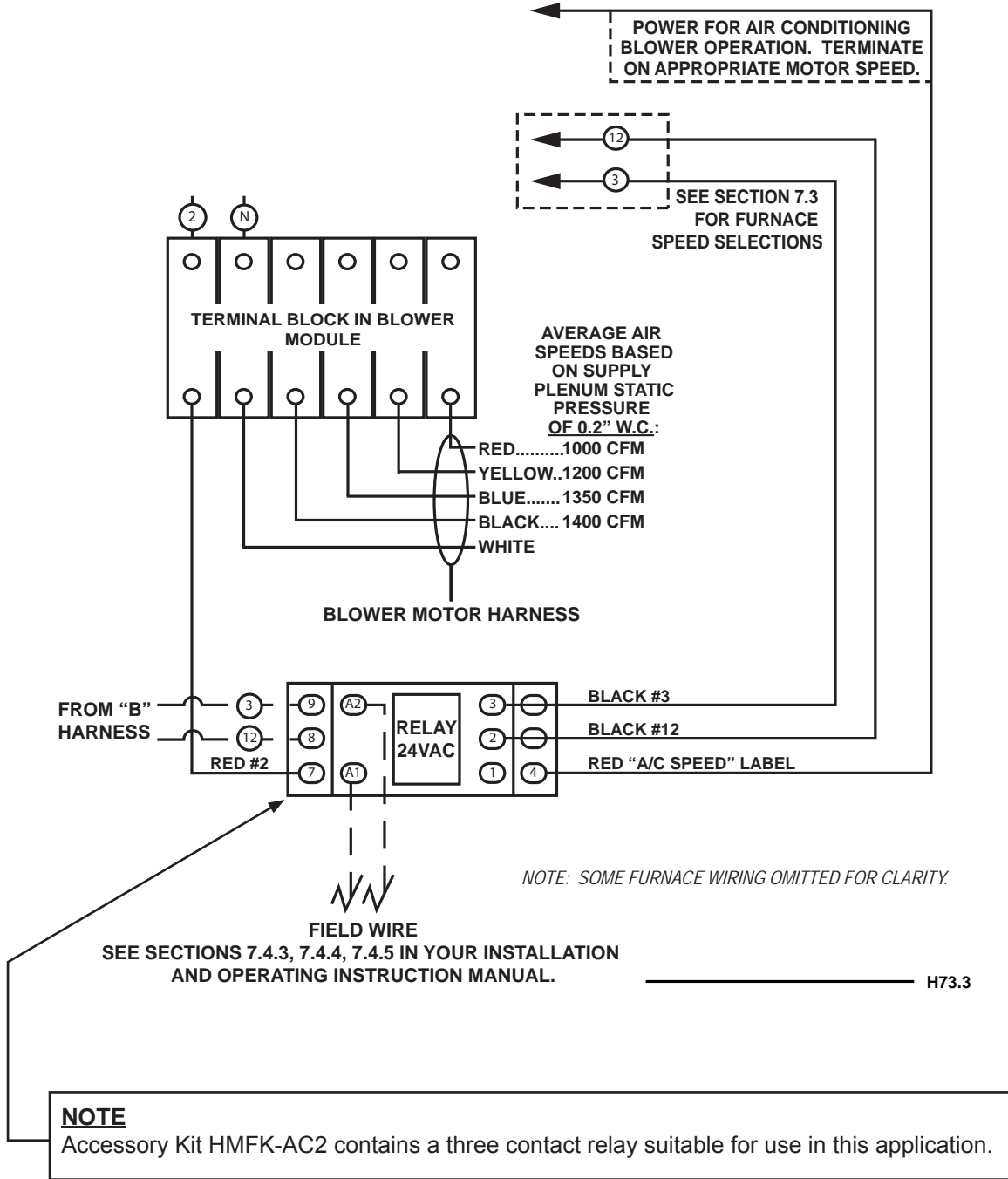

7.4.1 GENERAL HARNESS LAYOUT: ALL CONFIGURATIONS

EN

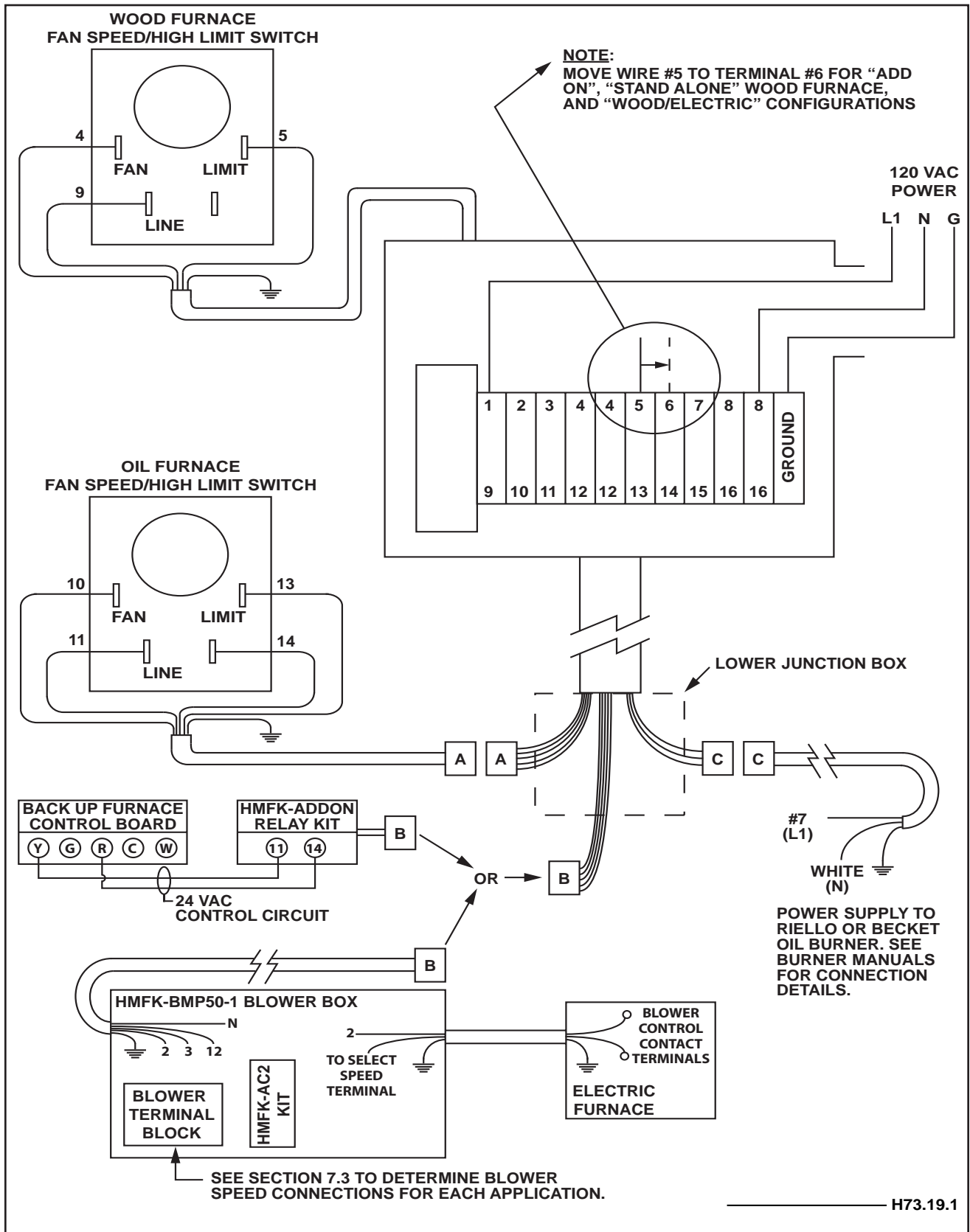

7.4.2 GENERAL HARNESS LAYOUT: WOOD/"ADD ON" CONFIGURATION INCLUDING NAPOLEON WOOD/GAS COMBO

EN

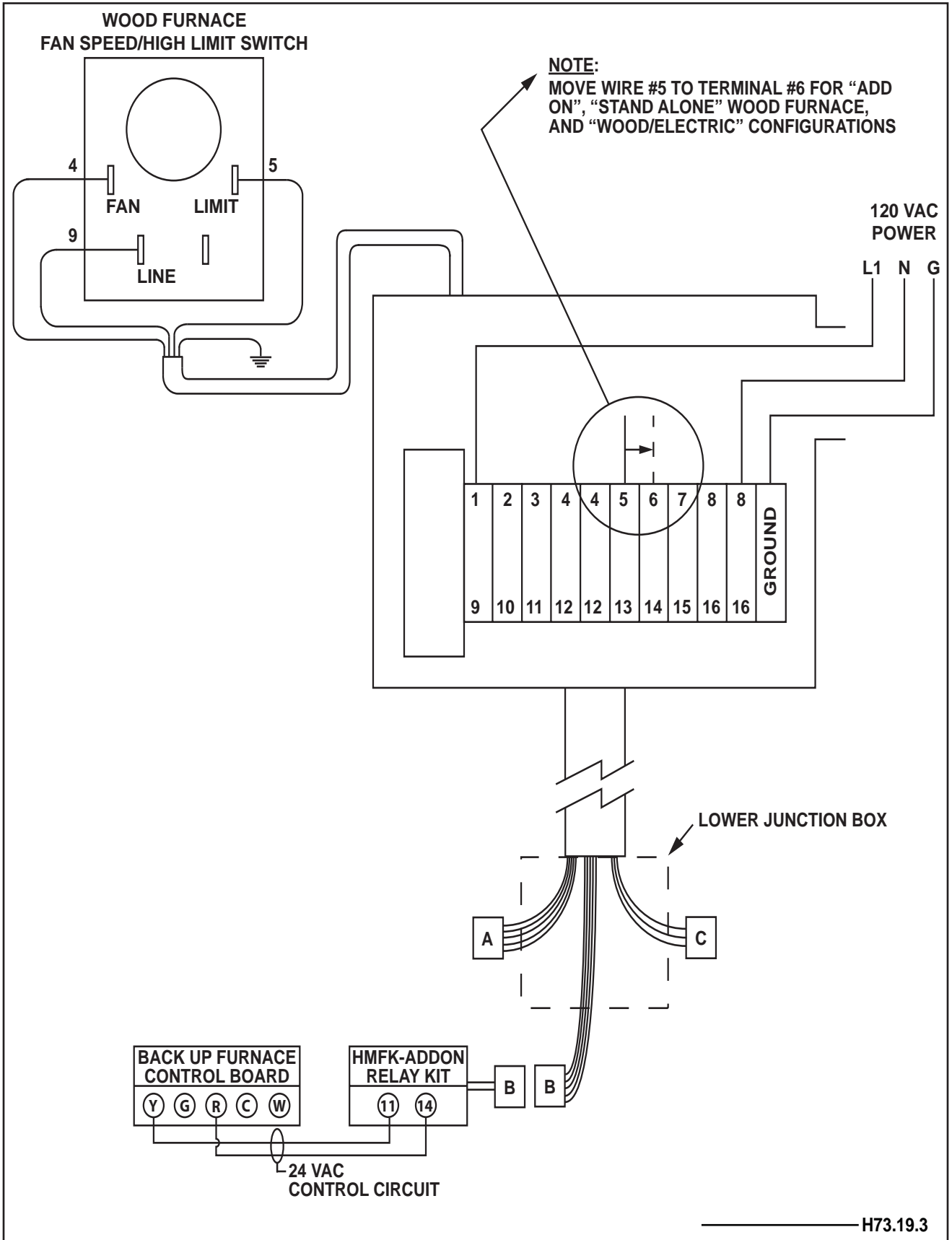

7.4.3 GENERAL HARNESS LAYOUT: WOOD CONFIGURATION

EN

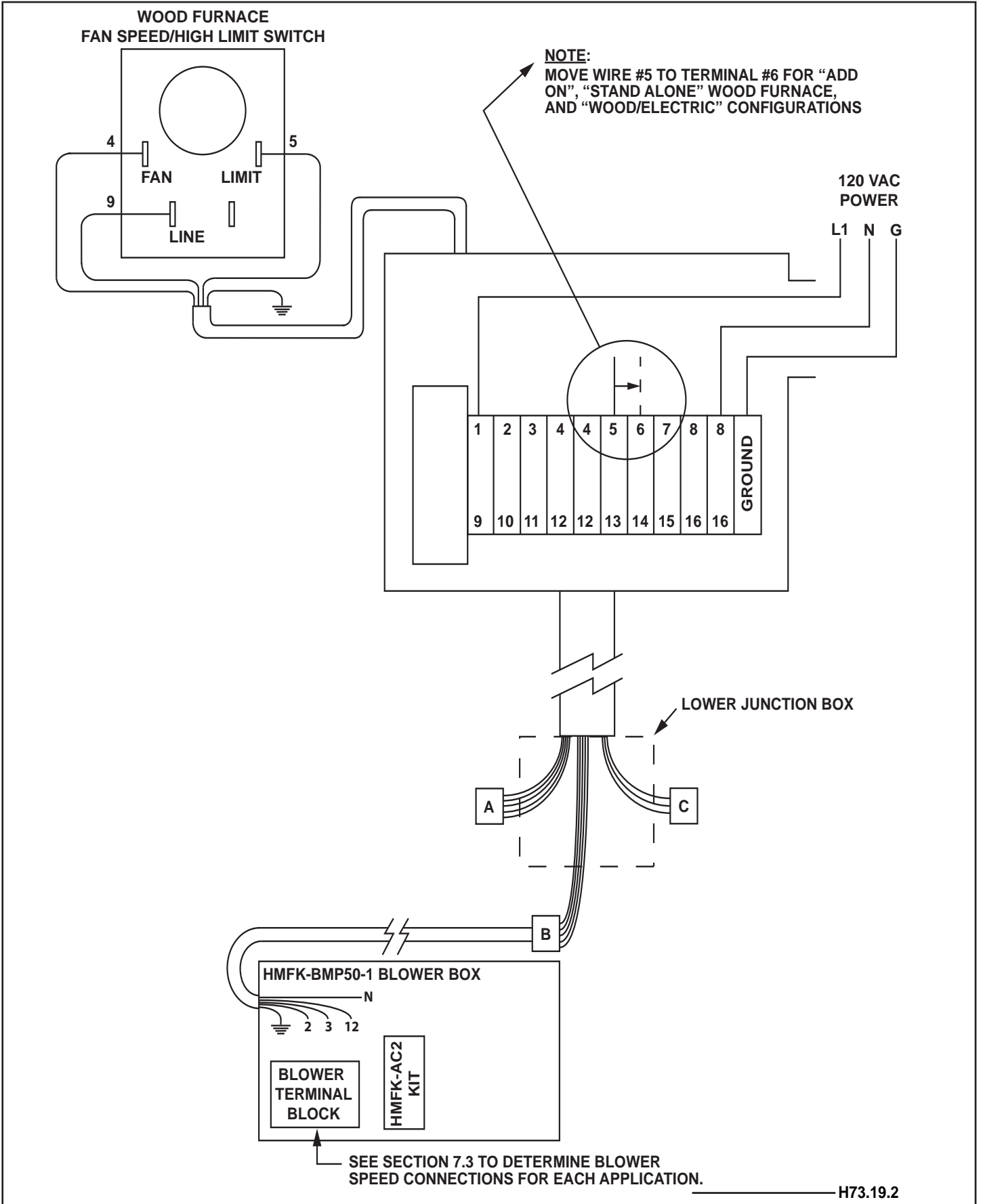

7.4.4 GENERAL HARNESS LAYOUT: WOOD/OIL CONFIGURATION

EN

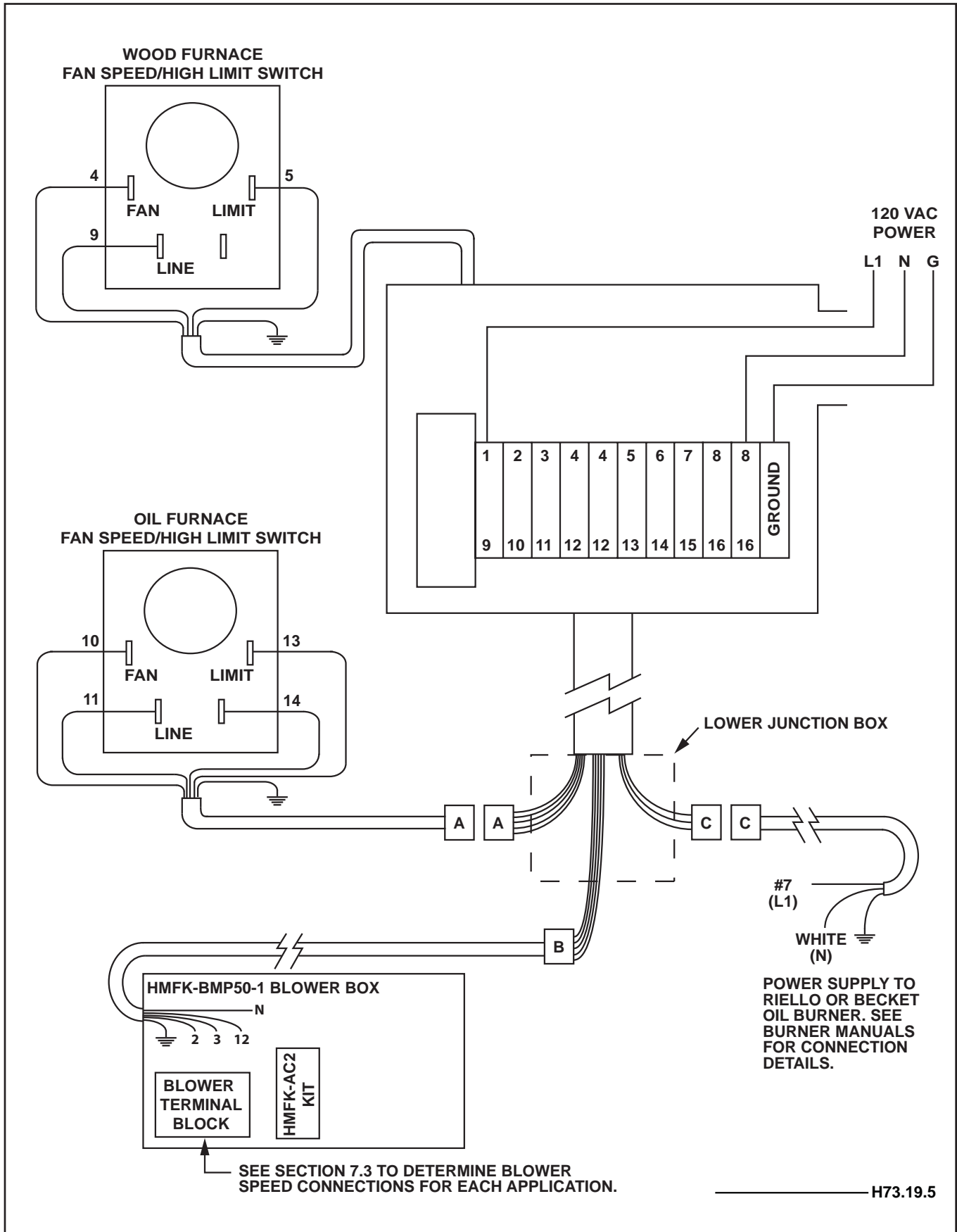

7.4.5 GENERAL HARNESS LAYOUT: WOOD/ELECTRIC CONFIGURATION

EN

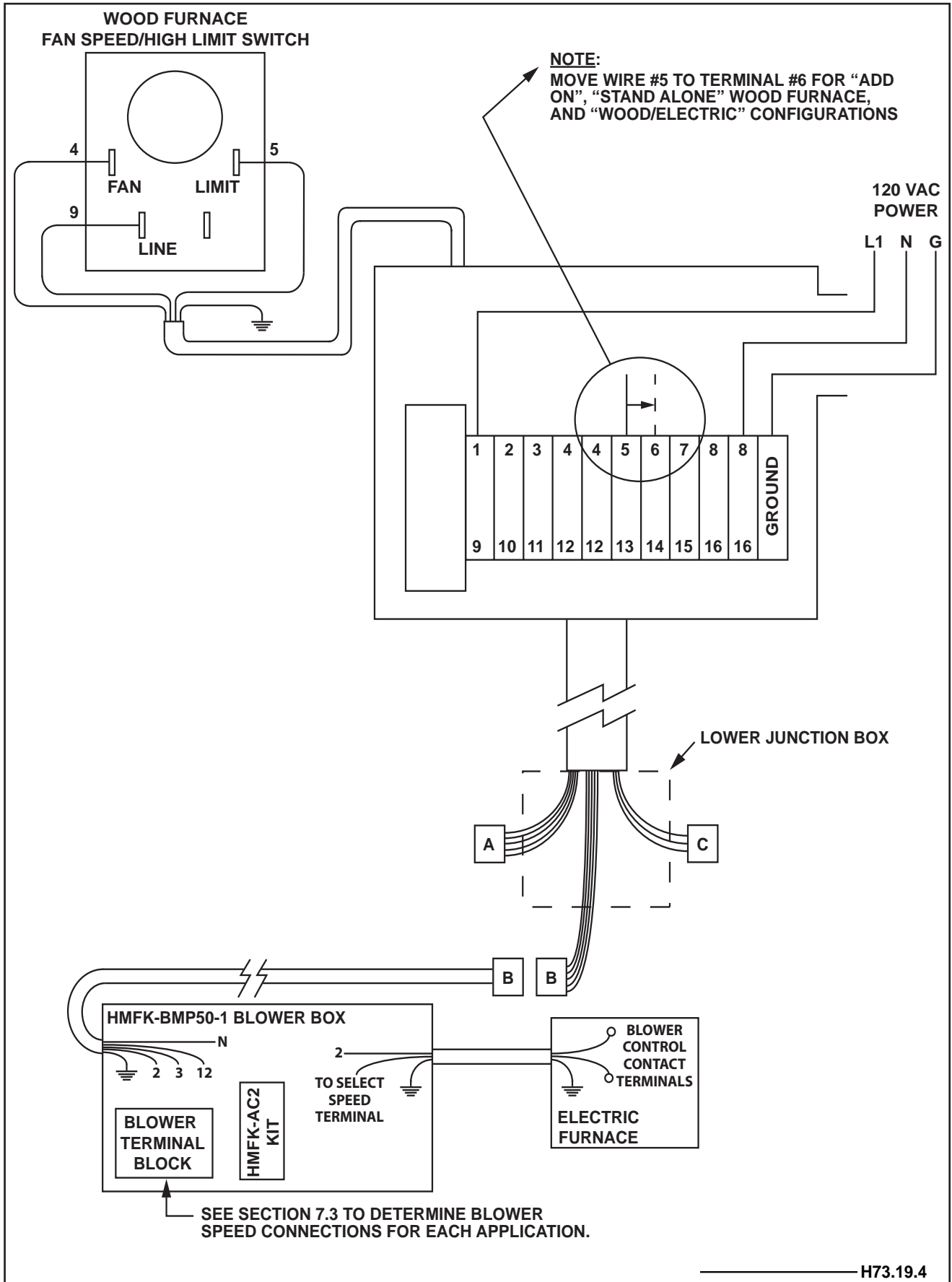

7.4.6 GENERAL HARNESS LAYOUT: WOOD/OIL/ELECTRIC CONFIGURATION

EN

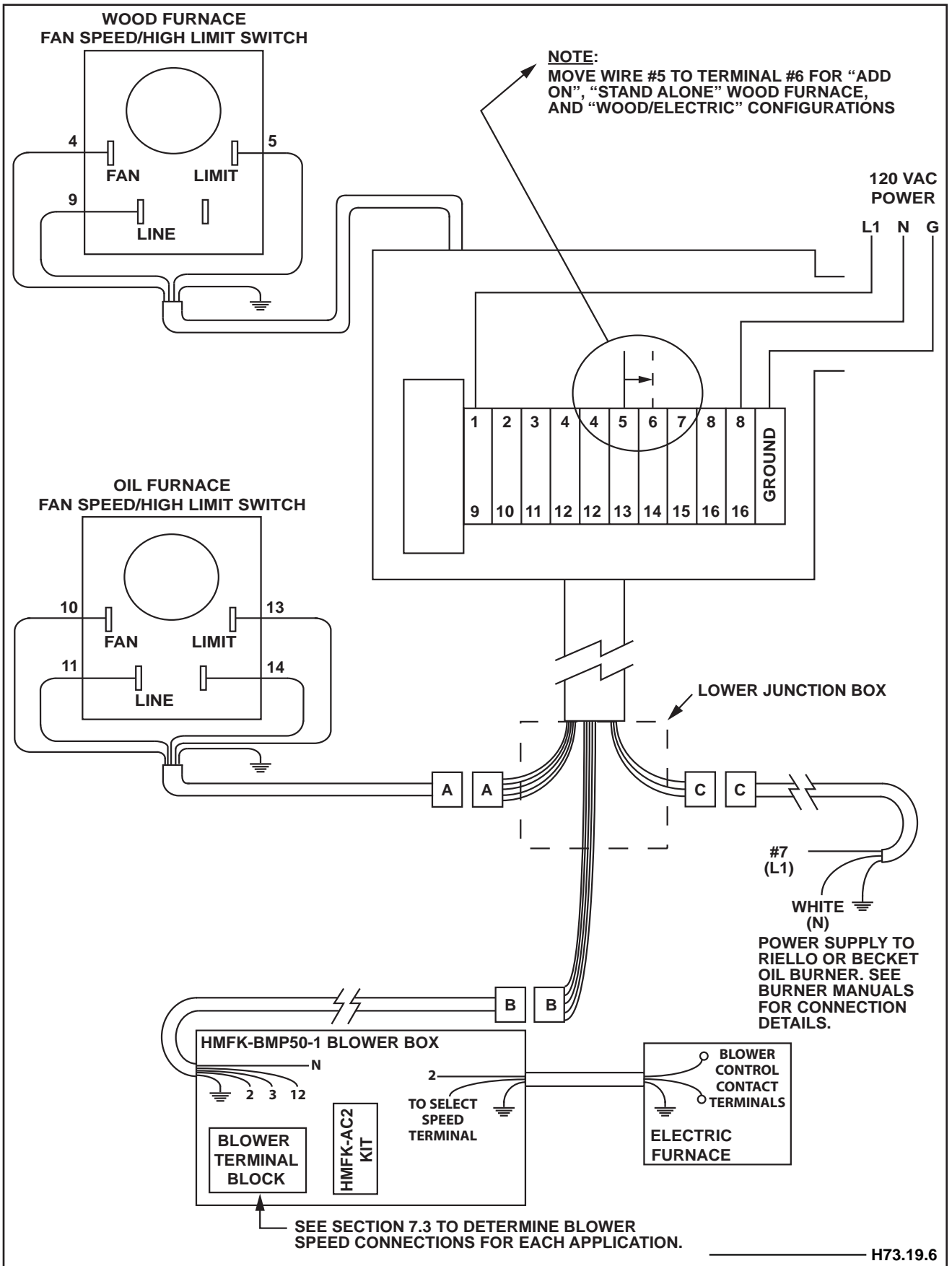

7.5 ELECTRIC SCHEMATICS - CONTROL WIRING WITHOUT AIR CONDITIONING

7.5.1 CONTROL WIRING WITHOUT AIR CONDITIONING: ALL CONFIGURATIONS

EN

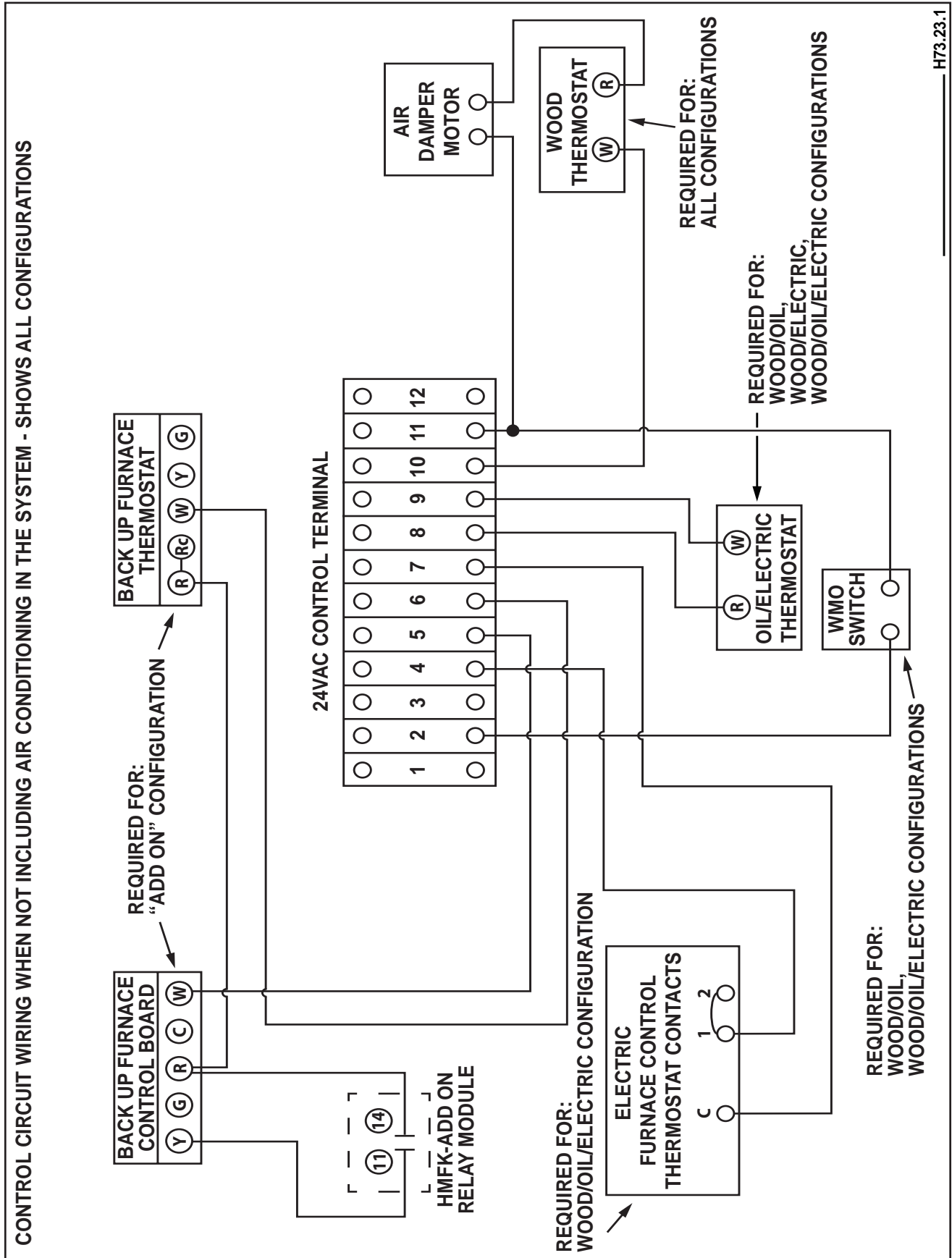

7.5.2 CONTROL WIRING WITHOUT AIR CONDITIONING: "ADD ON" FURNACE CONFIGURATION INCLUDING NAPOLEON WOOD/GAS COMBO

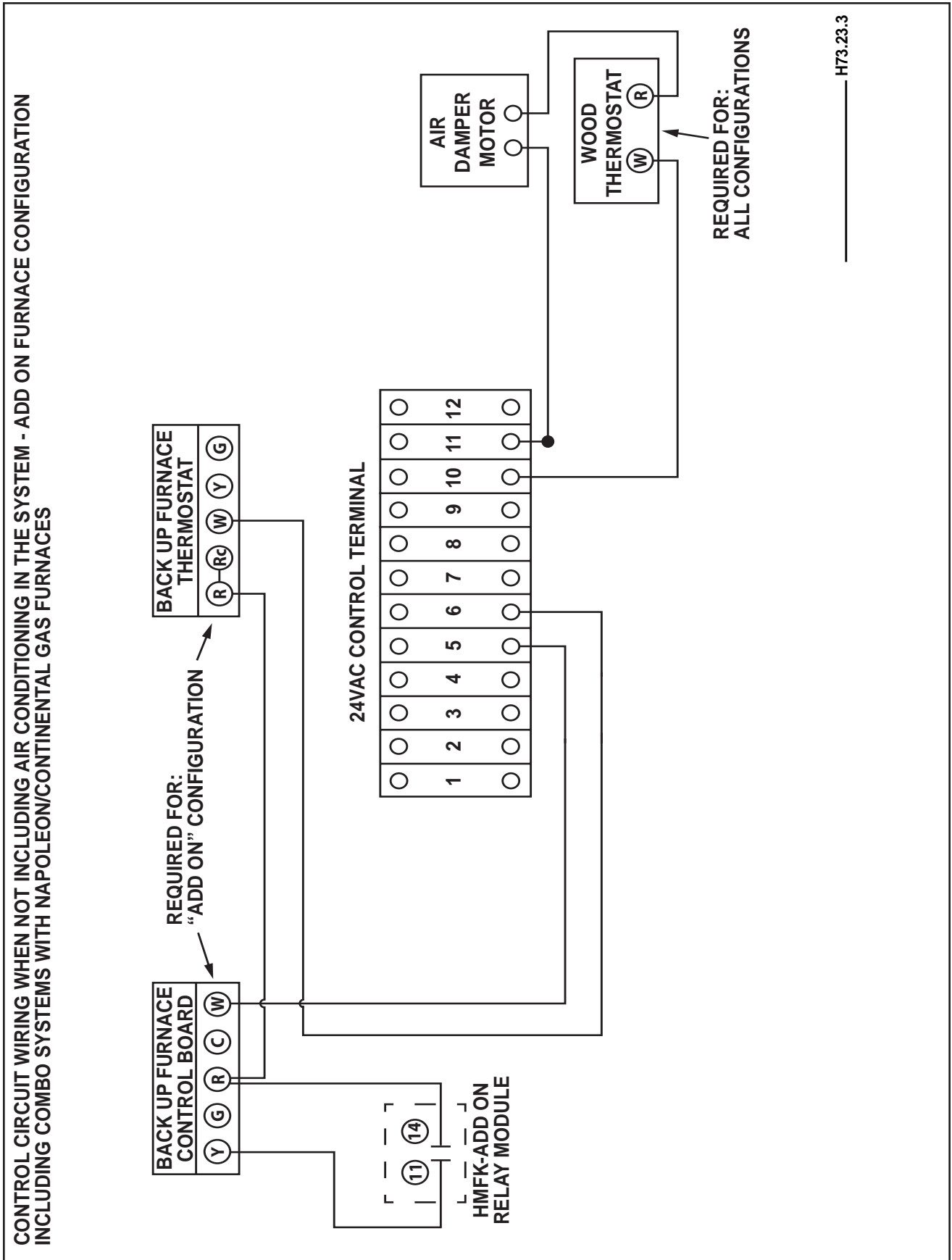

EN

7.5.3 CONTROL WIRING WITHOUT AIR CONDITIONING: WOOD FURNACE ONLY CONFIGURATION

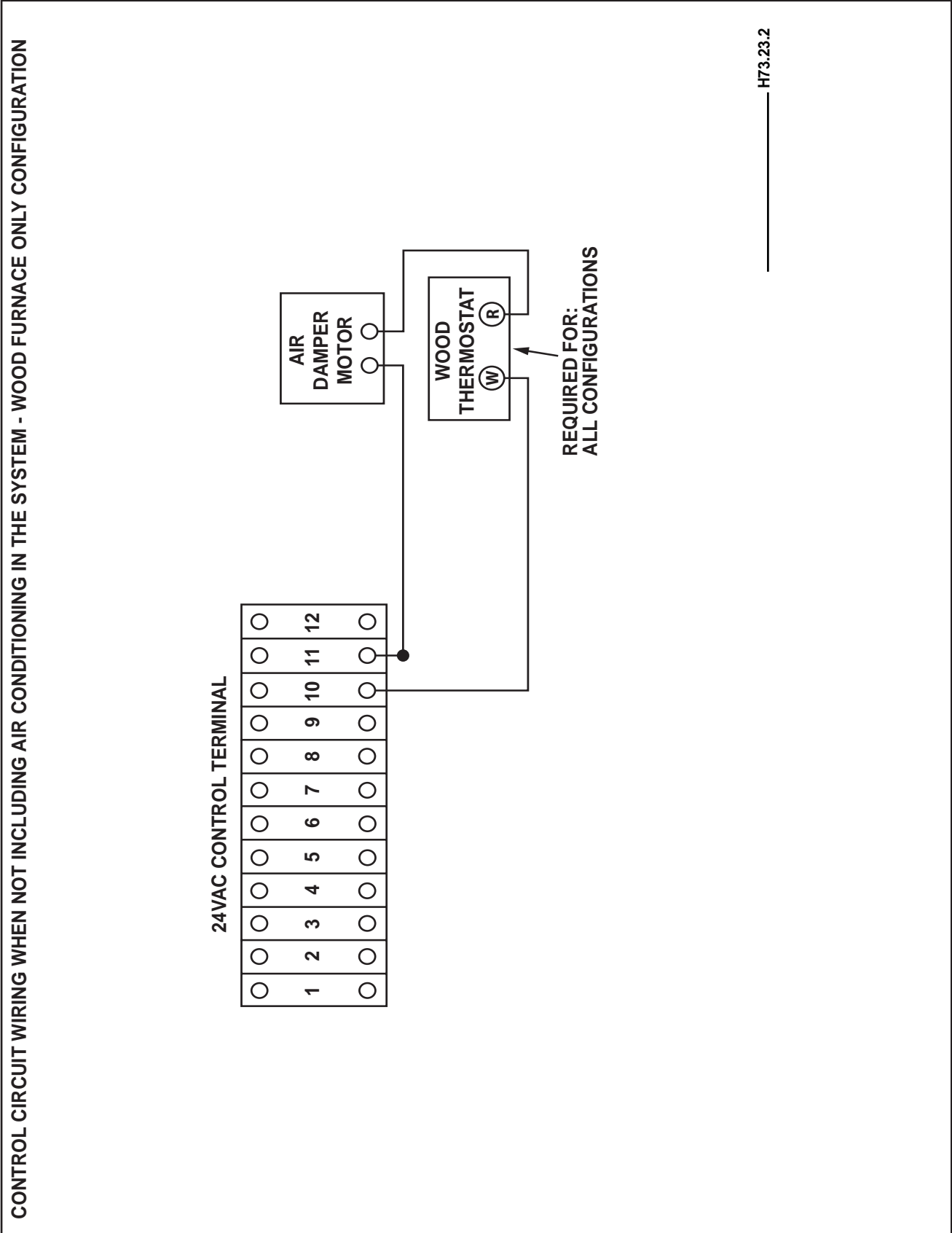

7.5.4 CONTROL WIRING WITHOUT AIR CONDITIONING: OIL FURNACE CONFIGURATION

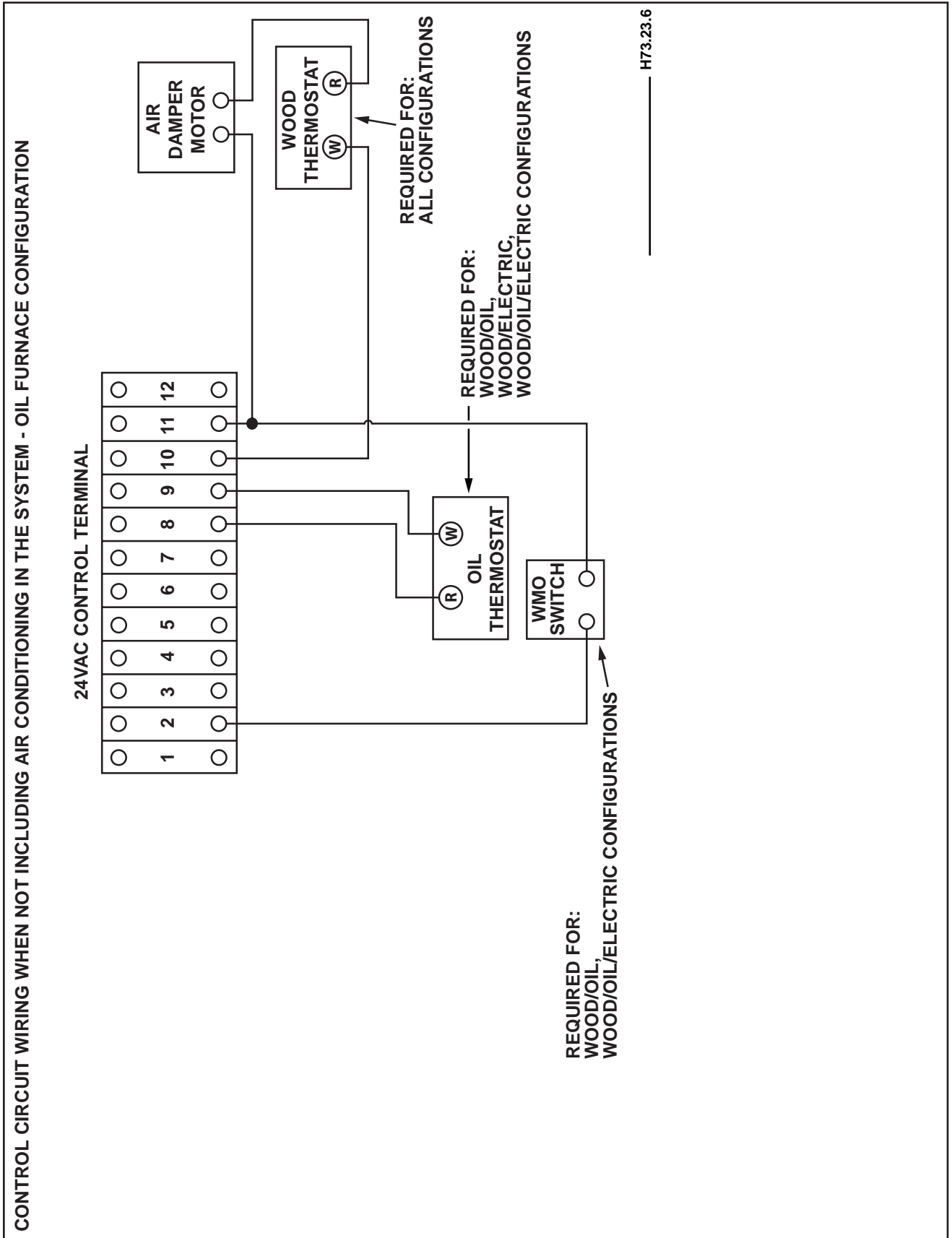

7.6 ELECTRIC SCHEMATICS - CONTROL WIRING WITH AIR CONDITIONING

7.6.1 CONTROL WIRING WITH AIR CONDITIONING: "ADD ON" FURNACE CONFIGURATION INCLUDING NAPOLEON WOOD/GAS COMBO

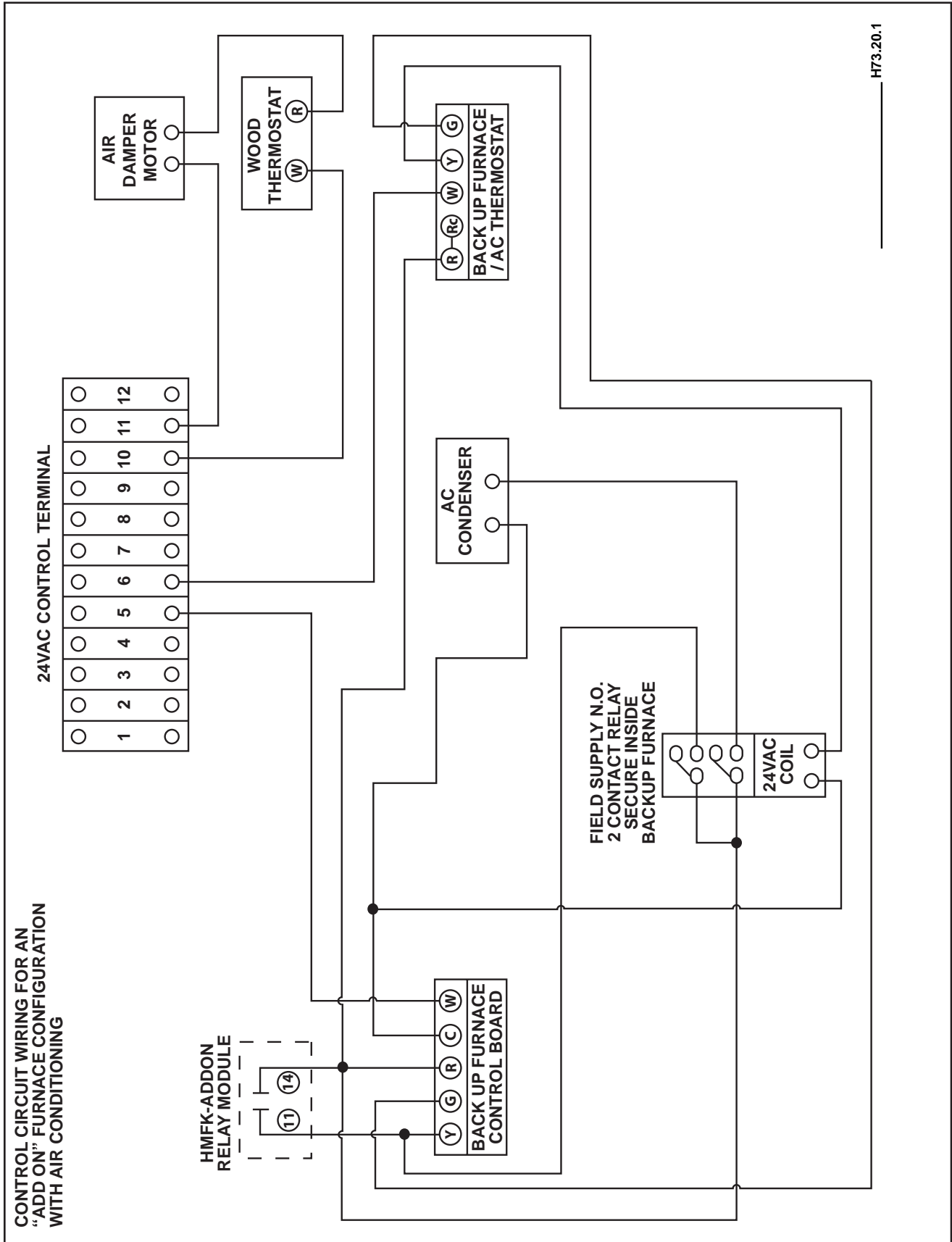

H73.20.1

7.6.2 CONTROL WIRING WITH AIR CONDITIONING: WOOD FURNACE ONLY CONFIGURATION

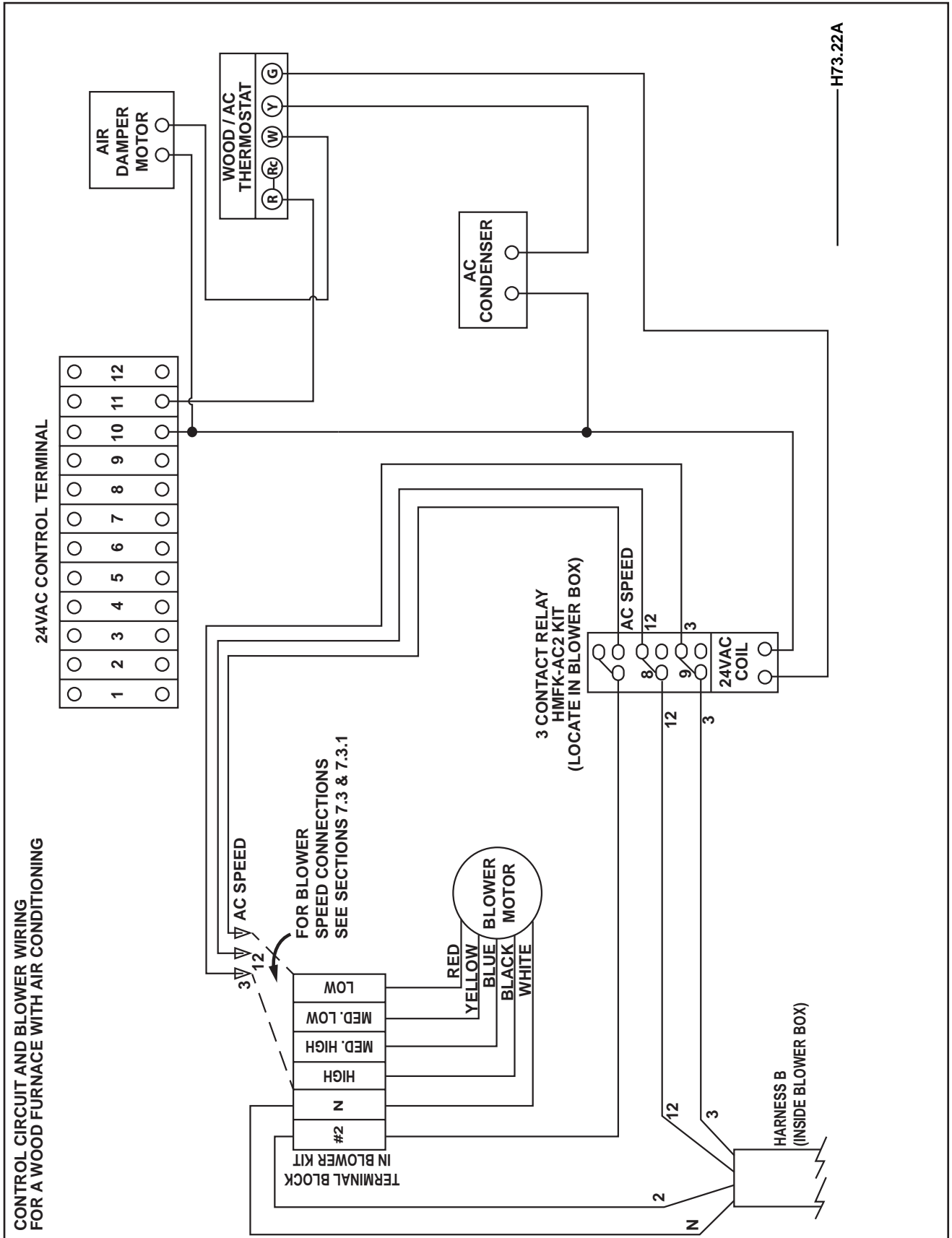

7.6.3 CONTROL WIRING WITH AIR CONDITIONING: WOOD/OIL FURNACE CONFIGURATION

EN

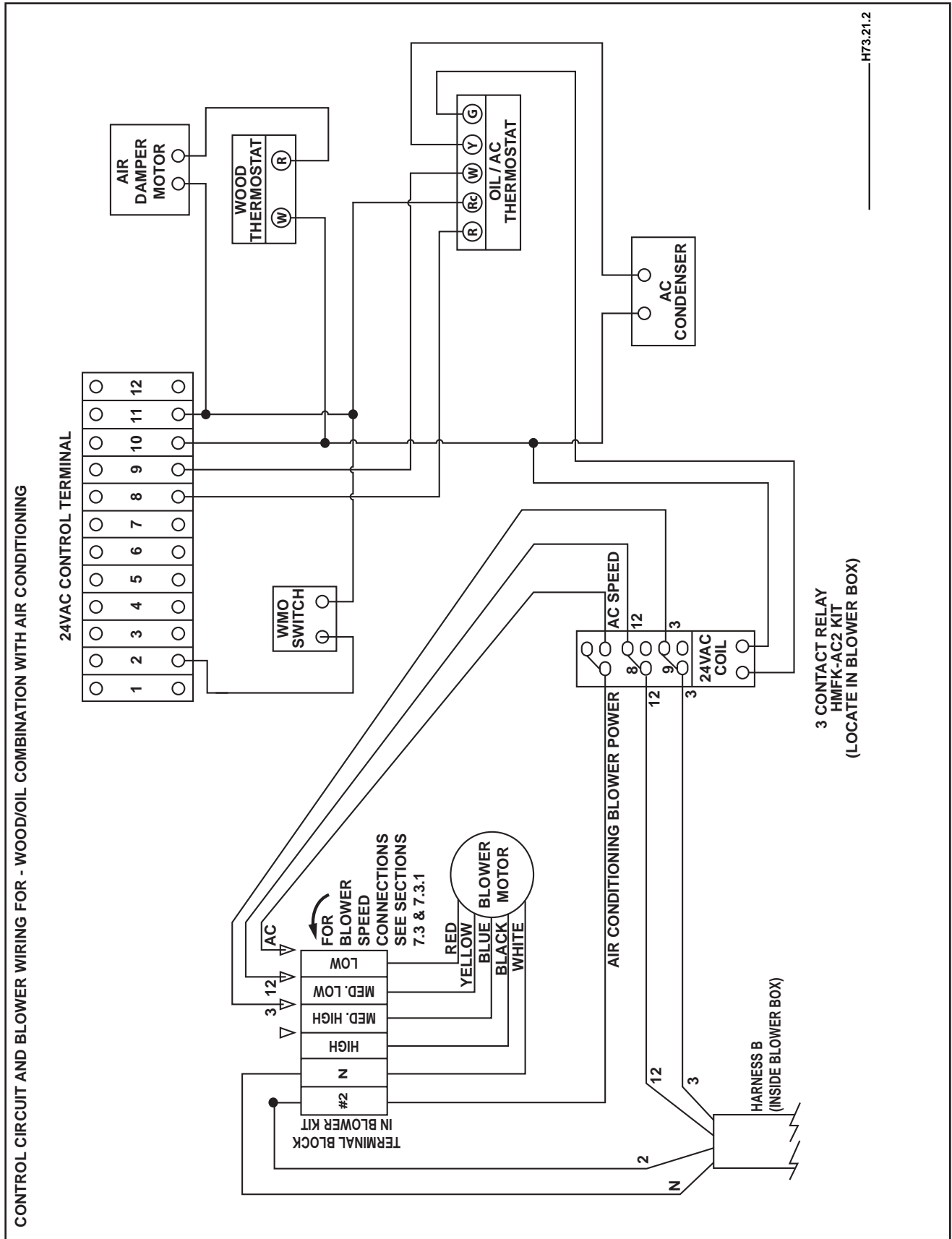

7.6.4 CONTROL WIRING WITH AIR CONDITIONING: WOOD/ELECTRIC FURNACE CONFIGURATION

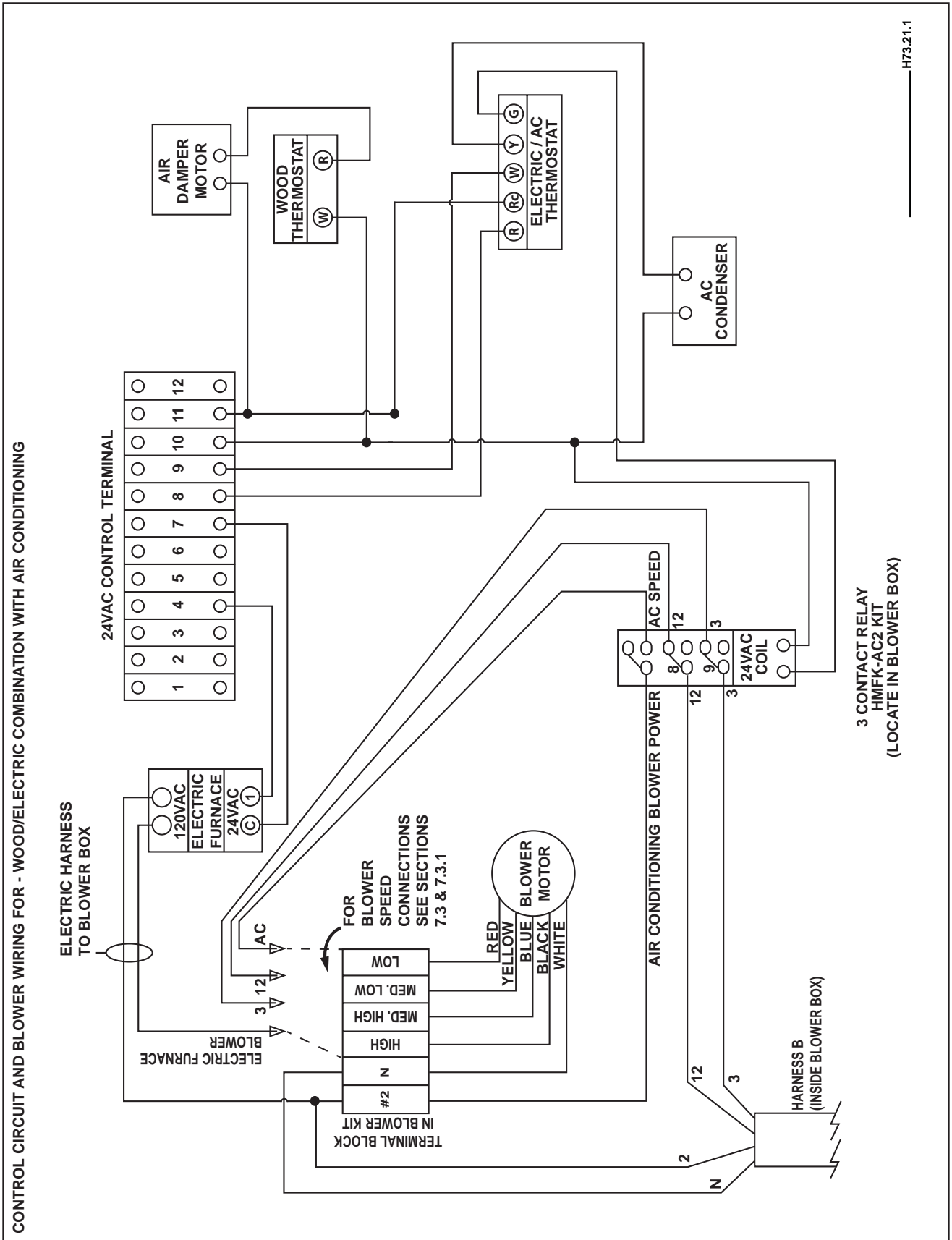

7.6.5 CONTROL WIRING WITH AIR CONDITIONING: WOOD/OIL/ELECTRIC FURNACE CONFIGURATION

EN

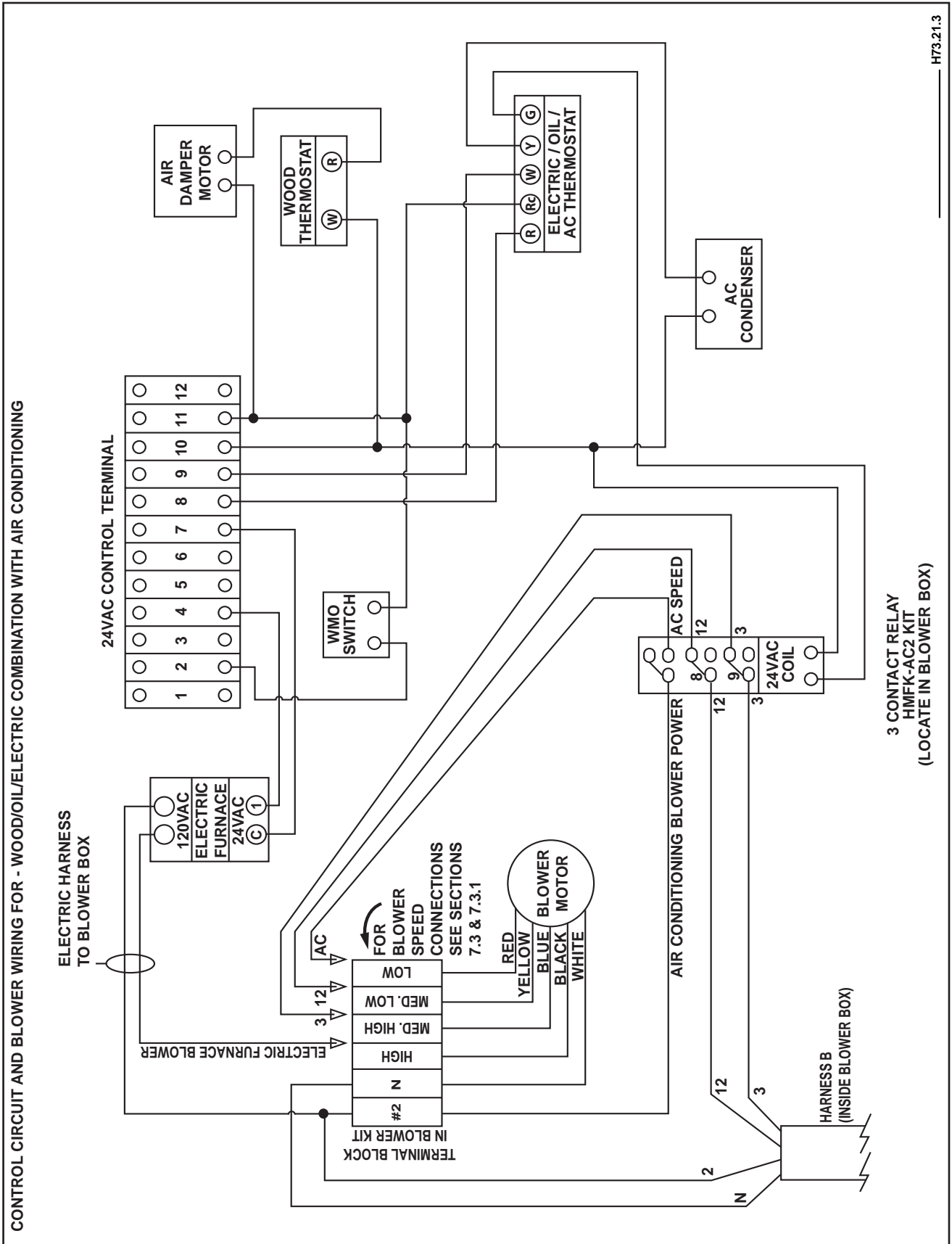

7.7 ELECTRIC SCHEMATICS - MAIN CONTROL HARNESS

EN

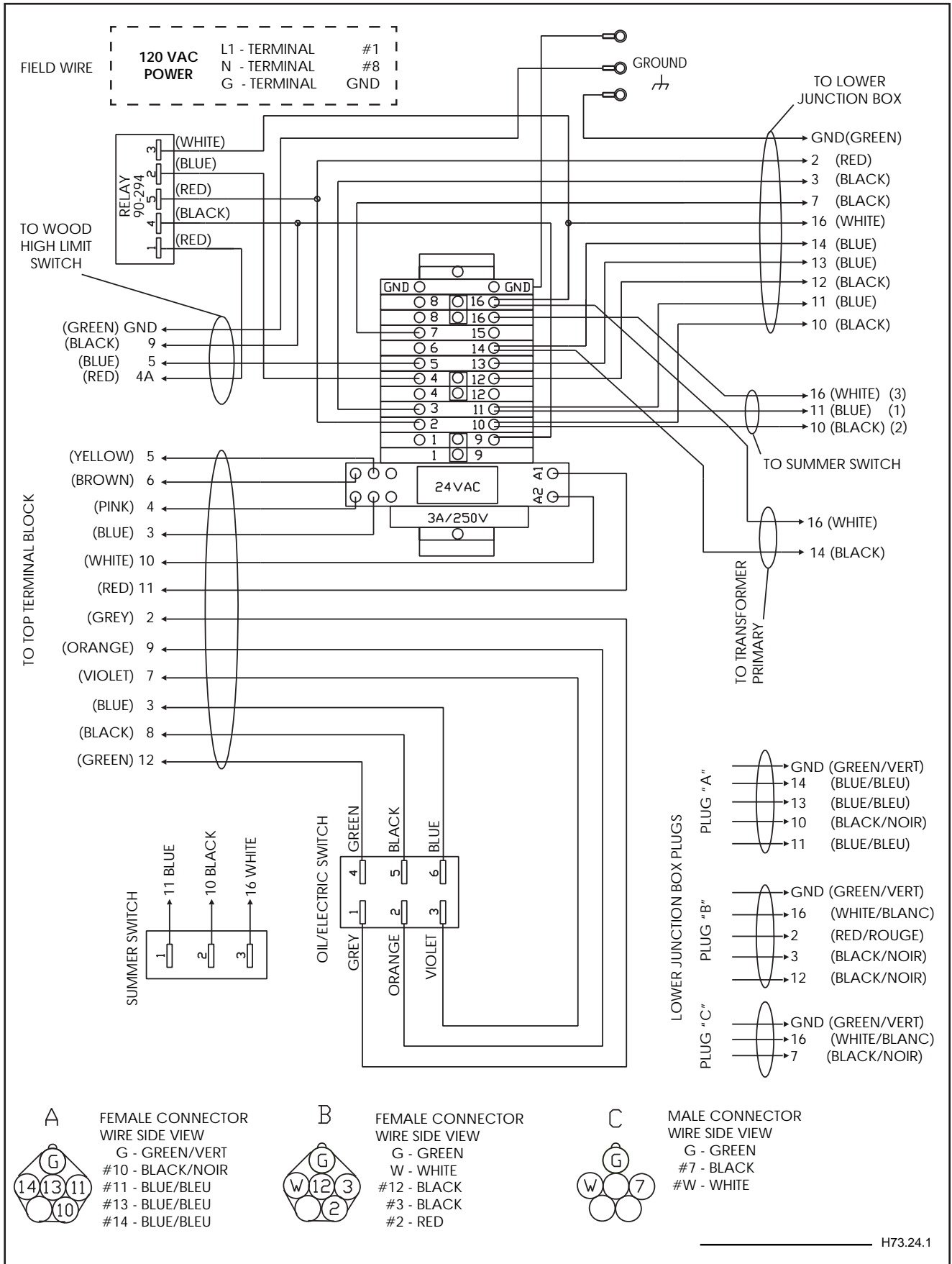

8.0 GENERAL OPERATING INSTRUCTIONS

8.1 OPERATION FOR HIGHER EFFIECIENCY AND LOWER EMISSIONS

This appliance complies with Step 1.0 For Warm Air Furnaces Under The New Source Performance Standards (NSPS), published by the EPA in the Federal Register on March 16, 2015.

This appliance has been certified to CSA B415.1-10 Emission Standards and is being reviewed for compliance with Step 1.1 or Step 1.2 of the NSPS requirements.

The heat output ranges, efficiencies, and particulate emission rates are as follows:

WOOD FURNACE:	<u>HMF150</u>	<u>HMF200</u>
Average Particulate Emisson Rate	0.18g/Mj	0.15g/Mj
Average Efficiency, Delivered Heat	52%	69.63%
Delivered Heat Output Rate:	MIN 18620 Kj/hr	27549 Kj/hr
	MAX 46161 Kj/hr	63345 Kj/hr
Average Efficiency, Overall Heat Output	72.1%	77.20%
Overall Heat Output Rate:	MIN 24930 Kj/hr	41436 Kj/hr
	MAX 70871 Kj/hr	66531 Kj/hr

The stated efficiency is based on the higher heating value of the fuel.

Results may vary from the data in the tables above based on actual installation and operating parameters encountered.

A basic operating parameter that can dramatically affect the performance of the furnace is the type and moisture content of the wood used as fuel.

To get the maximum efficiency and lowest emission performance from your furnace consider the following points:

- The corner stone for running any wood fired appliance is to only use split seasoned wood with low moisture content. For best results split wood should be aged outdoors in a covered space for a period of at least one year. When measured (with the moisture meter supplied with this furnace), the moisture content of the wood should not exceed 18%.
- Split dimensions of the wood can also play an important part in the performance of this furnace. Optimum performance of this furnace is obtained when running the fuel in full batches (loading the firebox with a full fuel load and not replenishing until it has burnt down to a shallow coal bed). For fuel packing and burn time purposes the ideal length of wood is one inch shorter than the length of the firebox and a pie shaped cross section measuring 4" to 6" (10 cm to 15 cm) wide by 6" to 8" (15 cm x 20 cm) high.
- The energy released and overall heating capacity differs when burning hardwood or softwood. Hardwood has a higher density than softwood and will give you more fuel by weight in the firebox. The energy content of the wood is also proportional to its weight, subsequently more energy is released by the hardwood.
- The draft created by the furnace/chimney installation is critical to the overall heat output efficiency and emissions created by the appliance. Note that the length of the chimney is not only dictated by the safety requirements of the local installation codes but by its ability to provide the right draft for optimum furnace performance. Without adequate draft the fire created can be lazy creating excessive smoke and particulate and not develop the heat output required. Too much draft can result in excess heat being drawn out the chimney instead of being released into the circulation air at the heat exchangers. In extreme cases too much draft can lead to over firing of the furnace and potential damage to property and life. The operating draft required for this appliance is between -0.04" to -0.06" water column.

8.2 SMOKE AND CARBON MONOXIDE EMISSIONS AND MONITORS

During the combustion process the presence of smoke is a strong indicator that the fuel is not being consumed efficiently. Smoke is created when the combustion air supply to the fuel load is inadequate to burn all the gases and particulate being released as the wood is consumed. This is why it is important to establish the correct draft with the furnace/chimney system. One of the bi-products of poor combustion is carbon monoxide.

Carbon monoxide is a colourless, odourless, and tasteless gas that is toxic when inhaled, and can be fatal depending on concentration levels and exposure time. Note that although carbon monoxide will be present in poor combustion process that creates smoke (as described above), it is not necessary for smoke to be present while high levels of carbon monoxide are being created. An example of this takes place when a wood fire has reduced down to the coal state and the draft starts to reduce as less heat is available to keep the chimney warm. Some level of carbon monoxide is being generated in all stages of the combustion process regardless of the fuel.

Several precautions can be taken to minimize the risk of carbon monoxide poisoning occurring.

- The first is to run the furnace in the most efficient manner possible to reduce the levels of carbon monoxide being generated. Using well seasoned dry wood and establishing the correct operating draft as laid out in these operating instructions will help limit CO emissions.
- Building Pressure - if the combustion air for an appliance (as with this wood furnace) comes from within the building that the appliance is located there will be a tendency for the internal building pressure to become negative. There must be adequate mechanical ventilation supplied to the building to neutralize the building pressure otherwise there is a risk of reversing the flow of exhaust flue products back into the building. These flue products may not only come from the wood furnace but also from other combustion appliances in the building. The Hybrid Wood Furnaces come supplied with a 4" (10 cm) vent for direct connection to outdoor combustion air. Although the wood furnace still relies on room air for the secondary burn process the connection of outdoor primary combustion air to the furnace will help reduce the amount of mechanical ventilation required to prevent negative building pressures.
- Smoke Alarms and Carbon Monoxide Detectors - Smoke alarms and carbon monoxide detectors are not only important tools for protecting the inhabitants of a building but they are mandated in many jurisdictions. Although these items should be located on every level of a building there are two locations that are of prime importance. The first is in the sleeping areas of the building, and the second is in the location to where the combustion process is taking place. Check with local codes for details of alarm/detector requirements.

8.3 CONTROL SYSTEM - WOOD FURNACE

Control of the woodburning section of the furnace is by adjustment of the primary air control located on the top rear right corner of the HMF150/200. This control operates in two set positions - "Full Open" allowing maximum combustion air delivery to the fire box and "Closed", providing minimum primary air to the fire box to assist the development of secondary or gasifying burn in the top of the fire box (Note that secondary combustion air enters through two inlets on the front of the furnace either side of the ash lip tray and is not adjustable).

! WARNING

IN NO WAY SHALL THE PRIMARY AIR CONTROL SYSTEM BE ALTERED TO INCREASE COMBUSTION AIR FLOW GREATER THAN THE FACTORY PRESET MAXIMUM.

H3.62

In the automatic mode the adjustment of primary air is accomplished using a shutter connected to a small servo motor. The control circuitry will energize the motor if it detects the room thermostat is calling for heat and the high limit sensor in the supply plenum has not been surpassed (greater than 250°F (121°C)). The primary air shutter will be fully opened and will remain so unless the room temperature has been satisfied or too much heat is detected in the plenum.

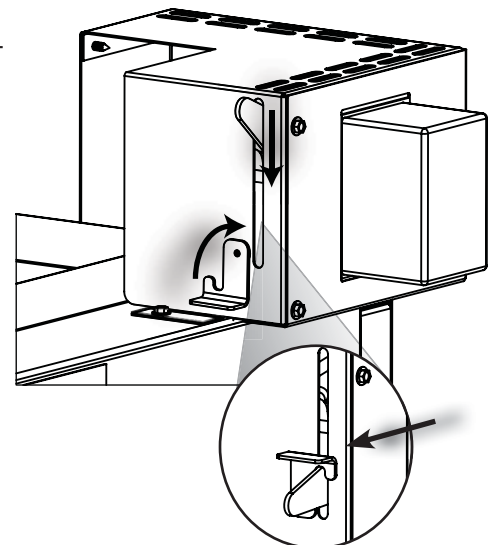

8.3.1 POWER OUTAGE OPERATION

 WARNING
HIGH TEMPERATURES CAN BUILD IN THE DUCT WORK, TO ENSURE AIR CIRCULATING IN A GRAVITY METHOD REMOVE AIR FILTER FROM FURNACE. ENSURE ALL SUPPLY AND RETURN AIR GRILLS ARE FREE FROM HOUSEHOLD OBJECTS OR DEBRIS, AND ENSURE ANY MANUAL DAMPERS IN THE DUCT NETWORK ARE FIXED IN A FULL OPEN CONDITION.
WITH THE MANUAL DAMPER LOCKED IN OPEN POSITION, THE FURNACE MUST BE MONITORED TO PREVENT OVER FIRING.
NEVER BUILD FLASH FIRES DURING A POWER OUTAGE OPERATION. SEE SECTION 8.9.

H3.63

In the case of a power outage it is possible to increase the output of the firebox by manually adjusting the primary air control shutter. On the front face of the primary air control box a control arm protrudes out. To increase combustion push down on this handle, moving it towards the bottom of the clearance slot, keep the control arm down by swinging the clasp (also mounted to the front of the primary air control box) over top of the control arm. This will continuously maintain the maximum combustion air being fed into the fire box (furnace must be monitored to prevent over firing). Although the blower fan will be inoperable in a power out situation, convection air flow through to the house will move under gravity circulation.

The air filter must be removed from the filter rack when operating in a power out condition to help promote gravity circulation and prevent excessive heating of the duct work.

8.4 CONTROL SYSTEM - SECONDARY FURNACE "ADD ON", "WOOD/OIL", "WOOD/ELECTRIC", "WOOD/OIL/ELECTRIC" CONFIGURATIONS

Control of the secondary heat source (either electric or oil) is done by a combination of a selector switch on the main furnace control panel and a second thermostat located beside and at the same height as the wood furnace thermostat. The selector toggle switch needs to be switched to the appropriate back up furnace installed (can be switched to either oil or electric depending on energy rates if both backups are installed). The thermostat for the back up heat source should be set 4°F to 5°F (2°C to 3°C) below the setting for the wood thermostat. Thus once the heat from the wood section starts to decline, the corresponding decline in room temperature will cause the second thermostat to call heat from the secondary heat source. Note that interlocks in the control system will force the secondary heat source to shut down if the temperature in the supply plenum of the wood furnace exceeds the set value of the "High Limit" switch (250°F) (121°C).

NOTE

The control of the "Add On" style installation is the same as the fore mentioned paragraph except for the position of the selector toggle switch being redundant.

 WARNING
BOTH OIL AND ELECTRIC FURNACES HAVE RESET CONTROLS AND PROCEDURES REQUIRED TO RESTART THE UNITS IF A FAULT HAS BEEN DETECTED AND UNITS LOCKED OUT. ONLY A QUALIFIED INSTALLER/SERVICE PERSON SHALL PERFORM THESE RESET PROCEDURES AS A CAUSE AND REPAIR MUST BE DETERMINED BEFORE THE UNIT CAN BE RESTARTED. FAILURE TO FOLLOW THIS STEP COULD RESULT IN PROPERTY DAMAGE, INJURY OR DEATH. SERVICE PERSONS CAN FIND TROUBLESHOOTING AND RESET PROCEDURE IN THE MANUALS ACCOMPANYING BOTH THE ELECTRIC FURNACE AND OIL BURNER MODULES.

H3.64

8.5 CONTROL SYSTEM - SUMMER FAN/CONTINUOUS FAN/HRV'S

A summer fan switch has been added to the main electric control box. This will provide low speed air circulation during the summer time when the furnace is not being used. Depress rocker switch to "Summer Fan" position, the switch will light and the fan will run.

There is also an override switch located on the wood/oil fan/limit switch. This should always remain pulled out in the "AUTO" position (pushing the button in will cause the fan to operate on high speed).

As an alternative, when the wood furnace is connected in a "Add On" configuration with a back up furnace, the continuous fan call on the back up thermostat, can be used to circulate air in the non-heating season.

Under no circumstances should any method (Summer Switch, Override Switch on Fan/Limits, Continuous Fan Mode on Back Up Furnace Thermostat) be used to provide continually circulating air when the wood furnace is being operated.

An HRV (Heat Recovery Ventilation System), can be connected to the HVAC system but must **NOT** be connected in such a way that it controls the operation of the circulation blower. The control logic shall be such when the wood furnace (or back up furnace in an "Add On" configuration) turns on the circulation blower, this should signal the HRV to operate.

WARNING

DO NOT USE "FAN SUMMER SWITCH (ON MODE)", "OVERRIDE SWITCHES (MANUAL POSITION)", "CONTINUOUS FAN OPERATION ON BACK UP FURNACE (IN "ADD ON" CONFIGURATION)", WHEN OPERATING THE WOOD FURNACE.

DO NOT CONNECT HRV'S SO THEY ARE CONTROLLING THE CYCLING OF THE FURNACE CIRCULATION BLOWER.

FAILURE TO COMPLY WITH THIS WILL RESULT IN EXCESSIVE COOLING OF THE EXHAUST PRODUCTS AS THEY PASS THROUGH THE EXCHANGER PIPES, THE FURNACE FLUE AND THE CHIMNEY SYSTEM. THIS COOLING WILL RESULT IN THE CONDENSATION OF EXHAUST PRODUCTS IN THE EXCHANGER AND CHIMNEY RESULTING IN EXCESSIVE CREOSOTE BUILD UP. THE CREOSOTE BUILD UP WILL RESULT IN REDUCED EFFICIENCIES OF THE EXCHANGER TUBES AND MAY CAUSE A CHIMNEY FIRE.

H3.65A

8.6 OPERATING SOUNDS AND SMELLS

Expansion / contraction noises during heating up and cooling down cycles are normal and to be expected.

When first installed, the furnace brick and metal are cold and must become hot before the appliance will function well. During the break-in period (the first 2 or 3 fires) create only small, hot fires using kindling; this will allow the firebrick to cure. Do not be alarmed if small hairline cracks develop in the firebrick. This is a normal occurrence and does not pose a safety hazard. The paint may also smell a little for the first few fires as it cures and you may wish to open a door or window to alleviate the smell.

There are many different ways to start a fire, review the hints and warnings in this section to ensure the fire is started properly.

8.7 STARTING A FIRE

EN

! WARNING
ALWAYS OPERATE THIS APPLIANCE WITH THE FIRE BOX DOOR CLOSED AND LATCHED EXCEPT DURING START UP AND RE-FUELING. ALWAYS WEAR GLOVES TO PREVENT INJURY. DO NOT LEAVE THE FIRE UNATTENDED WHEN THE DOOR IS UNLATCHED AS UNSTABLE WOOD COULD FALL OUT OF THE FIRE CHAMBER CREATING A FIRE HAZARD TO YOUR HOME.
ASH REMOVAL DOOR SHALL ALWAYS BE TIGHTLY CLOSED AND SEALED DURING OPERATION OF THE WOOD FURNACE, FAILURE TO DO SO WILL OVERFIRE AND DAMAGE THE FURNACE.
NEVER LEAVE CHILDREN UNATTENDED WHEN THERE IS A FIRE BURNING IN THE APPLIANCE.
DO NOT START A FIRE WITH CHEMICALS OR FLUIDS SUCH AS GASOLINE, ENGINE OIL, OR OTHER INAPPROPRIATE MATERIALS.
DO NOT OPERATE WITH FLUE DRAFT GREATER THAN 0.06 W.C. (15 Pa).
DO NOT STORE FUEL OR OTHER COMBUSTIBLE MATERIAL WITHIN MARKED INSTALLATION CLEARANCES OF THE APPLIANCES.
INSPECT AND CLEAN FLUES AND CHIMNEY REGULARLY.
HOT SURFACES - DO NOT TOUCH DURING OPERATION.
FREQUENTLY EXAMINE ALL DOOR SEALS/GASKETS, REPLACE IF WORN. FAILURE TO SHUT DOORS TIGHTLY AND IGNORING LEAKING GASKETS CAN RESULT IN EXTREME OVER FIRING CONDITIONS.

H3.66

! WARNING
RISK OF FIRE OR EXPLOSION - DO NOT BURN GARBAGE, GASOLINE, DRAIN OIL OR OTHER FLAMMABLE LIQUIDS.

H3.67

Make sure the air control lever is in "Full Open" position (thermostat should be calling for heat and the control rod should be near the bottom of the clearance slot. You may also open the firebox door 1" to 2" (25mm to 51mm) during the first five minutes of start-up, for additional information see Section 3.2 "Outside Combustion Air".

Opening the by-pass damper will help heat up the chimney more quickly. Close after draft is established, to start heating the exchanger tubes. By pass control rod can get extremely hot, use the removable hand tool for opening and closing by pass.

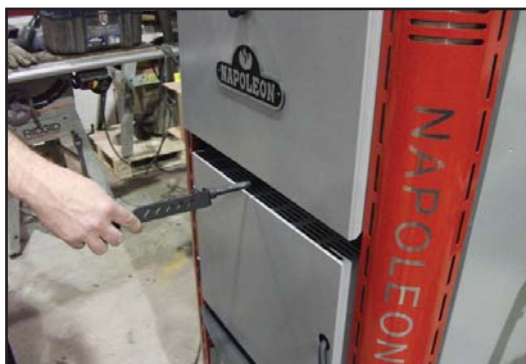
**NOTE**

By pass tool has mounting finger which easily slides into oblong vent slots on sides of corner posts for storage.



Never use gasoline, gasoline-type lantern fuel, kerosene, charcoal lighter fluid, or similar liquids to start or freshen-up a fire in this appliance. Keep all such liquids well away from the appliance while it is in use. If using a firestarter, use only products specifically designed for appliances - follow the manufacturer's instructions carefully.

Remove all source of gasoline or other flammable vapors and liquids in the vicinity of this or other appliances prior to lighting.

Use plenty of newspaper and kindling to ensure the appliance reaches a proper temperature. Once the kindling is burning rapidly, place a few larger pieces of wood onto the fire.

Tips:

When first lighting a fire, if the smoke is not quickly drawn into the chimney, there may be a downdraft or cold air in the chimney. By first burning large amounts of crumpled newspaper, the chimney will get heated and the smoke will quickly vent up the chimney.

- Create a large fire to heat up the appliance before adjusting to a slower burn.
- To create a large, quick burning fire, use small pieces of wood.
- For a lower, but extended burn, stack larger pieces of wood close together.
- For long burns, leave a 1-2" (25mm - 51mm) bed of coals (for best secondary burn performance, create a channel in the ashes down to the fire bricks).
- This channel should be 1" to 2" (25mm to 51mm) wide and run from the front centre to the rear centre of the fire box. This channel allows in rush air from the pilot at the front of the fire box to be heated in the coal bed and then driven up the rear of the fire box, where it can keep the secondary burn process ignited.
- Burn dry wood only.
- **Closing the door too quickly after refuelling will reduce the firebox temperature and may result in an unsatisfactory burn.**
- As soon as the door is closed, you may (if glass door is installed) observe a change in the flame pattern. The flames will get smaller and lazier because less oxygen is getting into the combustion chamber. The flames, however, are more efficient. The flames will remain lazy but become larger again as soon as the firebricks have been heated thoroughly and the chimney becomes heated and provides a good draft.
- With the doors opened the fire is wastefully drawing heated room air up the chimney, certainly not desirable. Always operate with the doors fully closed once the medium sized logs have caught fire.
- You can now add larger pieces of wood and operate the appliance normally. Once the appliance is entirely hot, it will burn very efficiently with little smoke from the chimney. There will be a bed of hot coals in the firebox so you can safely fill the firebox with wood to the bottom of the secondary air tubes.
- **Can't get the appliance operating?** Use more kindling and paper. Assuming the chimney and vent are sized correctly and there is sufficient combustion air, the lack of sufficiently *dry* quantities of *small* kindling is the problem. *Thumb size* is a good gauge for small kindling diameter.
- **Can't get heat out of the appliance?** One of two things may have happened. The appliance door may have been closed prematurely and the appliance itself has not reached optimum temperature. Re-open the door and/or draft control to re-establish a brisk fire. The other problem may have been wet wood. The typical symptom is sizzling wood and moisture being driven from the wood.

8.8 DRAFT CONTROL



WARNING

ALWAYS OPERATE THIS APPLIANCE WITH THE FIRE BOX DOOR CLOSED AND LATCHED EXCEPT DURING START-UP AND RE-FUELING.

H3.68

Draft is the force which moves air from the appliance up through the chimney. The amount of draft in your chimney depends on the length of the chimney, local geography, nearby obstructions and other forces. Adjusting the draft control regulates the temperature. The draft can be adjusted via the thermostat from a low burn rate with the air control on the low setting to a fast burn rate with the air control on the high setting.

Inadequate draft may cause back-puffing into the room and may cause plugging of the chimney. Too much

draft may cause an excessive temperature in the appliance, glowing red appliance parts or an uncontrollable burn which can all lead to a chimney fire or a permanent damage to the appliance.

Roll up some newspaper, light it and place it near the appliance flue until the chimney begins to draw. When a fire is burning, open the door slowly to avoid drawing smoke into the room.

NOTE

Differences in the chimney height and draft may lower overall burn times.

EN

8.9 FUEL LOADING AND BURN CYCLE

! WARNING

BURN WOOD DIRECTLY ON THE FIREBRICKS. DO NOT USE ELEVATED GRATE OR OTHERWISE RAISE THE FIRE.

DO NOT STORE WOOD WITHIN APPLIANCE INSTALLATION CLEARANCES OR WITHIN THE SPACE REQUIRED FOR RE-FUELING AND ASH REMOVAL.

H3.69

! CAUTION !**DOUBLE LATCH SYSTEM**

The firebox door is equipped with a double latch system. To close the door hold the door handle at the 12 o'clock position as door swings to meet the firebox. Once the door has made contact with the firebox, the door handle can be turned clockwise to the 3 o'clock position. In the 12 to 3 o'clock positions, the 1st latch will have engaged and will allow the door to be cracked open by approximately 1/4" (0.6 cm). This is useful to help create draft while starting a fire, but the latch should not remain in this position once fire is established. Do not try to force the door handle past the 3 o'clock position while on the 1st latch as this can damage the mechanism. To completely seal the door for normal operation the 2nd latch must be engaged. To do this, push the door tightly against the firebox and continue turning the handle clockwise to the 5 o'clock position. The door should now provide an air tight seal with the firebox.

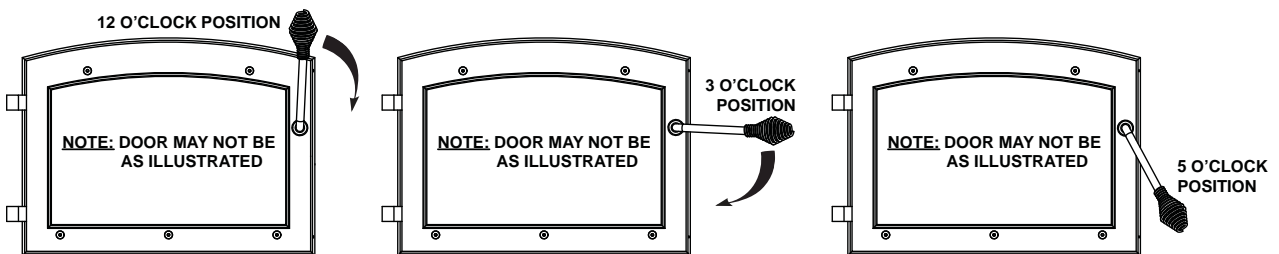
DOOR LATCH POSITIONS:

The bricks will be nearly all white and the glass mostly clear. The whiteness of the bricks and the cleanness of the glass (if equipped) are good indicators of your operating efficiency.

Not enough heat is produced when only one or two pieces of wood are burned.

A minimum of three pieces are needed to encase a bed of coals that sustains the fire. Loosely stacked wood burns quicker than a tightly packed load.

Wood burns in cycles rather than giving a steady output of heat. It is best to plan these cycles around your household routine so that only enough coals are left to start the next load. In the evening, load your appliance, at least, a half-hour before bed to ensure the fire is hot enough to close the draft control for an overnight burn.

Burn only dry seasoned wood. It produces more heat and less soot or creosote. Do not burn ocean beach wood. Its salt content can produce a metal eating acid.

8.10 RE-LOADING THE APPLIANCE

When refuelling open the bypass damper and then slowly open the door to prevent smoke spillage. Use a pair of long appliance gloves when feeding the fire. Keep a small steel shovel nearby to use as a poker and to remove ashes. Do not store wood within 4 feet (1m) of the appliance.

Follow the directions below to minimize smoke spillage while re-loading the appliance.

- A. Open the exhaust bypass damper by sliding control rod out.
- B. Open the door slightly.

IMPORTANT:

Door is constructed with a double latch system which when door handle is rotated slowly in a counter clockwise direction, will pop the door open slightly to allow pressure equalization, before further rotation in the clockwise direction completely disengages latch.

Allow the airflow inside the firebox to stabilize before opening the doors fully.

- C. Load wood to the bottom of the secondary air tubes - loading above this point could dislodge or damage fire box baffles leading to dangerous over firing.

WARNING

ALWAYS ENSURE THE DOOR IS COMPLETELY SEALED WHEN HANDLE IS ROTATED CLOCKWISE AND THE DOUBLE LATCH IS COMPLETELY ENGAGED. DO NOT ALLOW FURNACE TO RUN WITH A SLIGHTLY AJAR DOOR. THIS CAN RESULT IN OVER FIRING, AS WELL AS A POTENTIAL FIRE HAZARD.

H3.70

- D. Close fire box door and bypass damper.

WARNING

BURNING WET, UNSEASONED WOOD CAN CAUSE EXCESSIVE CREOSOTE ACCUMULATION. WHEN IGNITED IT CAN CAUSE A CHIMNEY FIRE THAT MAY RESULT IN A SERIOUS HOUSE FIRE.

H3.71

8.11 FLASH FIRES

A flash fire is created by igniting a very loosely stacked pile of kindling (typically but not restricted to wood with a cross section less than 1" X 1" (25mm X 25mm)). A major characteristic of a flash fire is that the wood is piled in such a way that the volume of the fuel pile can consist of as much if not more air space as there is wood fuel. The intensity of the flash fire can be greatly increased if supply of combustion air is increased (fire box or ash doors left open during fire). Although small flash fires are a part of developing a charcoal bed when starting the furnace up from a cold start they can create unsafe operating conditions, damage to the furnace and void all warranties. Flash fires may only be used when starting the furnace from a cold start and the fuel stack should never occupy more than 1/3 of the firebox volume. Do not create or maintain flash fires once the furnace is capable of sustaining operating using regular full size wood in tightly packed bundles. Never create a flash fire during a power out condition, damage to the furnace is likely and all warranties will be void. Typical symptoms of flash fires which have caused over firing include glowing furnace components and melted exterior paint.

H93.2

8.12 SMOKING

A properly installed appliance should not smoke. If yours does, check the following:

- Has the chimney had time to get hot?
- Is the smoke passage blocked anywhere in the appliance, chimney connector or chimney?
- Is the room too airtight and the air intake not connected to the outside? Try with a window partly open.
- Is the smoke flow impeded by too long a horizontal pipe or too many bends?
- Is it a weak draft perhaps caused by a leaky chimney, a cold outside chimney, too large a diameter of a chimney, too short a chimney, or a chimney too close to trees or a higher roof?
- Is the moisture content of the wood greater than 20%?

R3 1A

8.13 ASH REMOVAL PROCEDURES

⚠ WARNING
ASH REMOVAL DOOR SHALL ALWAYS BE TIGHTLY CLOSED EXCEPT WHEN COAL BED IS EXTINGUISHED AND ASH ARE BEING REMOVED FROM FURNACE.
OPEN OR POORLY SEALED ASH REMOVAL DOORS DURING NORMAL OPERATION OF THE FURNACE CAN CAUSE A FORGE AFFECT ON THE FUEL LOAD AND CAUSE THE FURNACE TO OVER FIRE. THIS COULD RESULT IN DAMAGE TO THE FURNACE, PROPERTY DAMAGE OR PERSONAL INJURY.
IMPROPER DISPOSAL OF ASHES RESULT IN FIRES. DO NOT DISCARD ASHES IN CARDBOARD BOXES, DUMP IN BACK YARDS, OR STORE IN GARAGES.
IF USING A VACUUM TO CLEAN UP ASHES, BE SURE THE ASHES ARE ENTIRELY COOLED. USING A VACUUM TO CLEAN UP WARM ASHES COULD CAUSE A FIRE INSIDE THE VACUUM.

H3.72

A bed of ashes approximately 1" (25mm) deep should be left on the firebox bottom to help maintain a hot charcoal bed. When the fire has burned down and cooled, remove any excess ashes. To remove the ash, follow the directions below.

- A. After the last coal has extinguished, let the appliance cool at least two hours.
- B. Open the appliance doors.
- C. Move ashes through the grate in the fire box floor, open the ash removal door and slide out the ash pan. Place the ashes into a steel container with a tightly fitting lid. Other waste shall not be placed in this container. Replace the ash pan and ensure the ash removal door is tightly closed. Cover the container with the lid and move the container away from the appliance onto a suitable non-combustible surface outdoors where the ashes can safely cool away from any combustibles. Dispose of the ashes.

8.14 INSPECTION OF HEAT EXCHANGERS, FLUES AND CHIMNEYS

IMPORTANT:

- Establish a routine for the storage of fuel, care of appliance, and firing techniques.
- Check daily for creosote build up until experience shows how often cleaning is necessary.
- Be aware that the hotter the fire, the less creosote is deposited, and that weekly cleanings may be necessary in mild weather, even though monthly cleanings may be enough in the coldest months.
- Have a clearly understood plan to handle a chimney fire.
- See Section 9.8 for instructions for creosote removal.

⚠ WARNING
INSPECT FLUE PIPES, FLUE PIPE JOINTS, AND FLUE PIPE SEALS REGULARLY TO ENSURE THAT SMOKE AND FLUE GASES ARE NOT DRAWN INTO, AND CIRCULATED BY THE AIR CIRCULATION SYSTEM.

H3.73

⚠ CAUTION ⚠
The heat exchanger, flue pipe and chimney must be inspected frequently and cleaned regularly to remove accumulated creosote and ash. Under certain conditions of use, creosote build up may occur rapidly. Cleanout of the heat exchanger, flue pipe, chimney, and draft inducer, if used, is especially important at the end of the heating season to minimize corrosion during the summer months, caused by accumulated ash. The appliance, flue pipe and chimney must be maintained in good condition.

9.0 MAINTENANCE

9.1 RUN-AWAY OR CHIMNEY FIRE

WARNING

A CHIMNEY FIRE CAN PERMANENTLY DAMAGE YOUR CHIMNEY SYSTEM. THIS DAMAGE CAN ONLY BE REPAIRED BY REPLACING THE DAMAGED COMPONENT PARTS. CHIMNEY FIRES ARE NOT COVERED BY THE LIFETIME LIMITED WARRANTY.

H3.74

Run-away fires can be the result of FOUR major factors:

CAUSES:

1. Using incorrect fuel, or small fuel pieces which would normally be used as kindling.
2. Leaving the door ajar too long and creating extreme temperatures as the air rushes in the open door.
3. Improperly installed or worn gaskets.
4. Creosote build up in the chimney.

SOLUTIONS:

1. Do not burn treated or processed wood, coal, charcoal, coloured paper or cardboard.
2. Be careful not to over fire the appliance by leaving the door open too long after the initial start-up.
3. Replace worn, dried out (inflexible) gaskets.
4. Have chimney regularly cleaned.

WHAT TO DO IF A RUN-AWAY OR CHIMNEY FIRE STARTS:

1. Close the draft fully (lowest position) by shutting off thermostat, make sure fire box and ash removal doors are closed tightly and make sure by bypass damper is closed.
2. Call the local fire department.
3. Examine the chimney, attic and roof of the house, to see if any part has become hot enough to catch fire. If necessary spray with a fire extinguisher or water from a garden hose.
4. Do not operate the appliance again until you are certain the chimney has not been damaged.

H85.1

9.2 FIRE EXTINGUISHERS AND SMOKE DETECTORS

All homes with a solid fuel burning appliance should have at least one fire extinguisher in a central location, known to all, at least one smoke detector and carbon monoxide (CO) detector in the room containing the appliance. If the smoke detector sounds an alarm, correct the cause but do not de-activate or relocate the smoke detector. If the carbon monoxide detector sounds an alarm, immediately vent the area, evacuate and call your local fire department.

91.1A

9.3 GLASS AND GASKET REPLACEMENT

WARNING

BURNING YOUR APPLIANCE WITH THE DOORS OPEN OR AJAR CREATES A FIRE HAZARD THAT MAY RESULT IN A HOUSE AND OR CHIMNEY FIRE.

FREQUENTLY EXAMINE ALL DOOR SEALS/GASKETS, REPLACE IF WORN. FAILURE TO SHUT DOORS TIGHTLY AND IGNORING LEAKING GASKETS CAN RESULT IN EXTREME OVER FIRING CONDITIONS.

H3.75

At the end of each burning season inspect the fire box and ash door gasket ensuring that it is not worn or loose. Replace with proper fiberglass rope. The purpose of door gasketing is to seal the firebox. If the doors are not sealed, air leaks into the firebox, creating a quick burning fire. This situation is not desirable for over-night or extended burns.

Replace cracked or broken glass immediately. When re-installing the glass, be sure that the glass and gasket create a solid seal around door frame. Follow the instructions in Section 9.6 for glass replacement.

H88.1

Burn only dry, clean unpainted wood that has been seasoned. It produces more heat and less soot or creosote. Freshly cut wood contains about 50% moisture while after proper seasoning only about 20% of the water remains. As wood is burned, this water boils off consuming energy that should be used in heating. The wetter the wood, the less heat is given off and the more creosote is produced. Dry firewood has cracks in the end of the grain.

Both hardwood and softwood burn equally well in this appliance but hardwood is denser, will weigh more per cord and burn a little slower and longer.

Firewood should be split, stacked in a manner that air can get to all parts of it and covered in early spring to be ready for burning that fall. Dry firewood has cracks in the end grain.

Cut the wood so that it will fit horizontally, front to back, making for easier loading and less of a likelihood that the wood will roll onto the glass.

Manufactured firelogs made by compressing 100% natural wood fibre can be safely used as fuel. Do not use manufactured firelogs if they contain additives such as paraffin, wax, binders etc. Never burn more than two manufactured firelogs at a time.

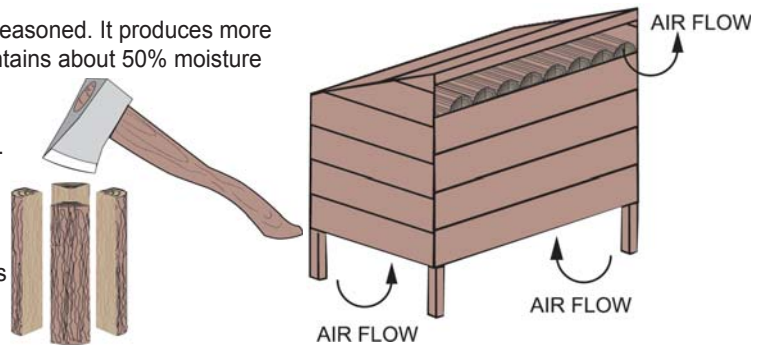

DO'S

- Build a hot fire.
- Verify with a moisture meter that wood contains at least 20% moisture content.
- Several pieces of medium sized wood are better than a few big pieces.
- Clean chimney regularly.
- Refuel frequently using medium sized wood.
- "Fine Tune" the air settings for optimum performance.

DONT'S

- Take ash out immediately. Let it accumulate to a depth of at least one inch. A good ash layer provides for a longer lasting and better burning fire.
- Burn wet wood with more than 20% moisture content.
- Close the door too soon or damper down too quickly.
- Burn one large log rather than two or three smaller, more reasonably sized logs.
- Burn at continually "low setting", if glass door is constantly blackened. This means the firebox temperature is too low.

87.1C

9.6 GLASS REPLACEMENT

! WARNING

DO NOT USE SUBSTITUTE MATERIALS.

GLASS MAY BE HOT, DO NOT TOUCH GLASS UNTIL COOLED.

CARE MUST BE TAKEN WHEN REMOVING AND DISPOSING OF ANY BROKEN DOOR GLASS OR DAMAGED COMPONENTS. BE SURE TO VACUUM UP ANY BROKEN GLASS FROM INSIDE THE APPLIANCE BEFORE OPERATION.

DO NOT STRIKE, SLAM OR SCRATCH GLASS. DO NOT OPERATE APPLIANCE WITH GLASS REMOVED, CRACKED, BROKEN OR SCRATCHED.

1. When the appliance is cool, open the door and place the door frame down careful not to scratch the paint.
2. Remove the screws and brackets holding the glass in place. Remove all broken glass.
3. Wrap the edges of the new glass with a U-shaped strip of fiberglass gasket, covering 1/4" (6mm) on each side.
4. Place the glass with the fiberglass gasket in position and replace the brackets and screws. When finished, you should be able to move the glass slightly, horizontally and vertically.

NOTE

For replacement glass, size, thickness and specifications see "REPLACEMENTS" section.

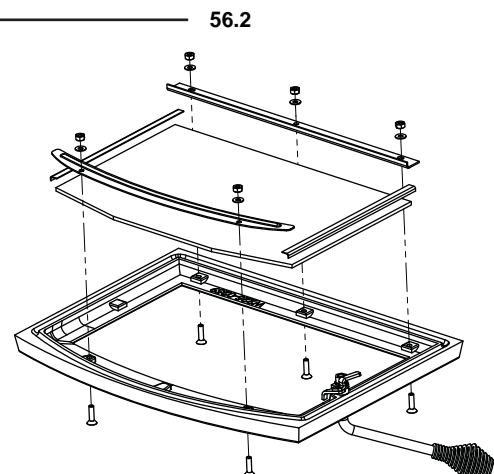

9.7 INSULATION INSERT REPLACEMENT

At the end of each burning season inspect the fire box door fibre insulation and guard for deterioration or breakage. Replace if necessary.

1. When the appliance is cool, open the door and place the door frame down careful not to scratch the paint.
2. Remove the two bolts holding the fibre insulation and guard to the door.
3. Remove and replace the fibre insulation and/or guard as necessary. Pay close attention to the correct position of the fibre insulation and guard. The angled side of the insulation **MUST** be positioned towards the top of the door.
4. Replace the two bolts and tighten them lightly. Over tightening the bolts may cause damage to the fibre insulation and will not allow the guard to expand in the heat.
5. Inspect the fibreglass gasket around the edges of the metal plate behind the fibre insulation. Replace as necessary. The entire insert, gasket, insulation, and guard can be replaced as a kit.

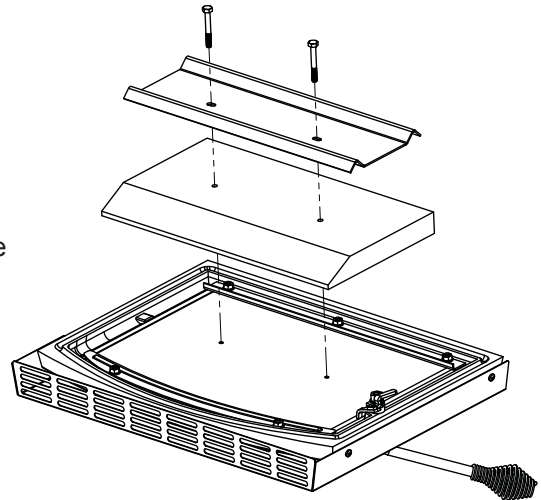

NOTE

For replacement fibre insulation, guard, or insert kit see "REPLACEMENTS" section.

9.8 CREOSOTE FORMATION AND REMOVAL

When wood is burned slowly, it produces tar and other organic vapors which combine with expelled moisture to form creosote. These creosote vapors condense in the relatively cooler chimney flue of a slow burning fire. As a result, creosote residue accumulates on the flue lining. When ignited, this creosote makes an extremely hot fire.

The chimney, chimney connector, and heat exchangers (if equipped), should be inspected at least once every week during the heating season to determine if a creosote buildup has occurred. Be aware that the hotter the fire, the less creosote is deposited, and a weekly cleaning might be necessary in mild weather, even though a substantially longer period without cleaning may be sufficient in colder months.

If creosote has accumulated, it should be removed to reduce the risk of a chimney fire.

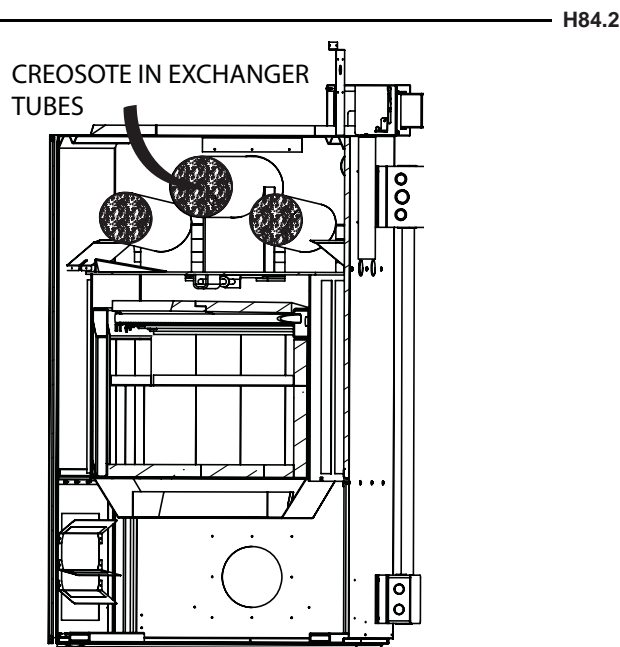

9.8.1 MAINTENANCE OF THE EXCHANGERS

The three heat exchanger pipes should be inspected regularly during the burning season. Easy access is provided (without the use of tools); simply unscrew the common knob on the exchanger access door, Figure 1.

Before cleaning the three exchanger pipes move the upper baffles of the combustion chamber forward (see Figure 2), and fully open the bypass damper.

Using the 5" (127mm) Poly Sweep brush and rod provided clean the three heat exchanger pipes. NOTE: The 5" (127mm) brush will be difficult to remove from the 2 smaller exchanger pipes for the first couple uses. It is recommended for the first use to lightly heat the plastic bristles with a heat gun until they are more pliable. Please note that excessive heat can damage the brush. After a couple uses the brush will loosen up and require less force.

The accumulated creosote will fall into the combustion chamber and can then be removed. Ensure the upper baffles are free of creosote and then push them back into their original position. Remove any excess creosote from the exchanger cleanout compartment and close the exchanger access door. Regular cleaning will ensure the greatest operating efficiency.

Figure 1



Figure 2

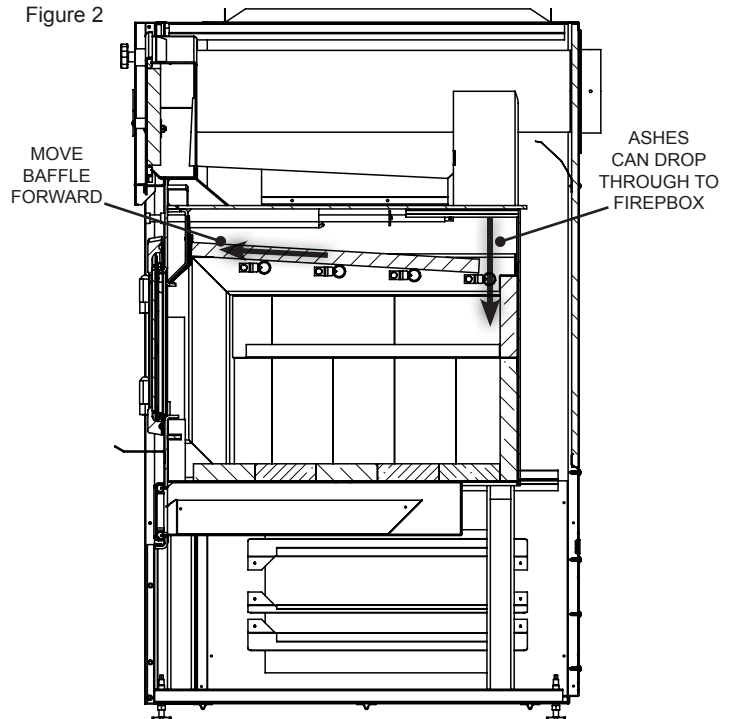

WARNING: REMEMBER TO REPOSITION BAFFLE TO REAR OF FIREBOX, FAILURE TO DO SO CAN RESULT IN OVER FIRED UNIT.

9.8.2 CHIMNEY MAINTENANCE

Both the chimney and the appliance must be inspected and cleaned if necessary at least once a year. For serious wood burners, chimney cleaning must be done as needed to avoid chimney fires; the venting systems for controlled combustion appliances may need cleaning as often as once a month. These rates, however, depend on the burning habits of the individual operating the appliance. For example, it is possible to clog a solid fuel appliance chimney in a few days if slow, smoldering fires are burned and the chimney is cold.

NOTE: Appliances burned consistently without hot fires may result in significant creosote accumulations in the chimney.

Certain items and considerations are important in chimney cleaning:

- Proper tools should be used, including a brush specifically designed for chimney cleaning.
- The chimney connector and dampers as well as the chimney should be cleaned.
- The appliance's firebox and baffle system should be cleaned if needed.
- The chimney should be inspected and repairs made if needed, preferably by a qualified chimney sweep or mason.

9.9 FILTERS

The furnace must not be operated without filters. In order to efficiently and safely operate a slow combustion heating system, you have to ensure a regular maintenance. This means that the chimney, the joints and the flue must be kept in good condition and the air filters must be replaced regularly; use standard capacity pleated air filters (16" x 25" x 1") (406mm x 635mm x 25mm).

9.10 BLOWER MOTOR LUBRICATION

For routine maintenance and improved bearing life, the two motor bearings can be lubricated with non detergent SAE 20 oil every 12 months.

DO NOT OVER LUBRICATE

H29.1

9.11 DOOR GASKET MAINTENANCE

It is important to maintain the door gasket in good condition. After a while, the gasket might sag; requiring replacement.

9.12 CARE OF GLASS (IF EQUIPPED)

If the glass is not kept clean permanent discolouration and / or blemishes may result. Normally a hot fire will clean the glass. The most common reasons for dirty glass include: not using sufficient fuel to get the appliance thoroughly hot, using green or wet wood, closing the draft so far that there is insufficient air for complete combustion. If it is necessary to clean the glass, buff lightly with a clean dry cloth and non-abrasive cleaner.



DO NOT CLEAN GLASS WHEN HOT! Clean the glass after the first 10 hours of operation with a recommended appliance glass cleaner. Thereafter clean as required.

The glass is very strong but do not let burning fuel rest or fall against it and always close the door gently. **NEVER FORCE IT SHUT!**

If the glass should ever crack or break while the fire is burning, do not open the door until the fire is out and do not operate the appliance again until the glass has been replaced, available from your Authorized dealer. **DO NOT SUBSTITUTE MATERIALS.**

5.3

10.0 REPLACEMENTS

Contact your dealer or the factory for questions concerning prices and policies on replacement parts. Normally all parts can be ordered through your Authorized dealer / distributor.

FOR WARRANTY REPLACEMENT PARTS, A PHOTOCOPY OF THE ORIGINAL INVOICE WILL BE REQUIRED TO HONOUR THE CLAIM.

When ordering replacement parts always give the following information:

- Model & Serial Number of appliance
- Installation date of appliance
- Part number
- Description of part
- Finish

FOR FURTHER INFORMATION, CONTACT YOUR AUTHORIZED DEALER.

! WARNING

FAILURE TO POSITION THE PARTS IN ACCORDANCE WITH THIS MANUAL OR FAILURE TO USE ONLY PARTS SPECIFICALLY APPROVED WITH THIS APPLIANCE MAY RESULT IN PROPERTY DAMAGE OR PERSONAL INJURY.

H41.1

APPLIANCE AND ACCESSORY REPLACEMENT PARTS	
PART NUMBER	DESCRIPTION
W010-1071	REPLACEMENT GLASS & GASKET
W020-0050	GLASS GASKET KIT
W010-2536	SOLID DOOR INSERT KIT
W361-0110	SOLID DOOR FIBRE INSULATION
W500-0725	SOLID DOOR SS GUARD
W020-0662	DOOR RETAINING HARDWARE KIT
HMFK-WMO	WMO THERMAL SAFETY SWITCH
W020-0661	OIL BURNER GASKET KIT
W020-0660	HMF FURNACE COMPLETE GASKET KIT
W090-0015	FIREBRICK "A" 1.25"x4.5"x9"
W090-0179	FIREBRICK "B" 1.25"x2.75"x9"
W090-0181	FIREBRICK "C" 1.25"x4.5"x6"
W090-0180	FIREBRICK "D" 1.25"x2.875"x4.5"
W090-0199	FIREBRICK "E" 1.25"x4.5"x4"
W090-0003	FIREBRICK "F" 1.25"x4.5"x4.5"
W090-0184	FIREBRICK "G" 1.25"x4.5"x8.5"
W090-0186	FIREBRICK "H" 1.25"x4.25"x6"
W010-2410	BAFFLES "I" (SET OF 2)
W080-1092	RETAINER "J"
W080-1093	RETAINER "K"
W090-0200	FIREBRICK "L" 1.25"x4.5"x8"
W090-0187	FIREBRICK "M" 1.25"x1.5"x6"
W090-0188	FIREBRICK "N" 1.25"x1.5"x9"
W090-0198	FIREBRICK "O" 1.25"x1.875"x9"
W090-0189	FIREBRICK "P" 1.25"x4.5"x5.5"
W090-0017	FIREBRICK "Q" 4.5"x1.5"x1.25"
W080-1145	RETAINER "R"
W010-2549	BAFFLES "S" (SET OF 2)
W090-0203	FIREBRICK LTWT "T" 1.25"x4.5"x3"
W090-0204	FIREBRICK LTWT "U" 1.25"x4.5"x5"
W090-0205	FIREBRICK LTWT "V" 1.25"x3.5"x8.5"
W090-0206	FIREBRICK LTWT "W" 1.25"x1.875"x8"
W435-0003	PRIMARY AIR SERVO MOTOR
W720-0157	SECONDARY AIR TUBE (HMF150)

APPLIANCE AND ACCESSORY REPLACEMENT PARTS	
PART NUMBER	DESCRIPTION
W720-0158	REAR SECONDARY AIR TUBE (HMF200)
W720-0159	FRONT SECONDARY AIR TUBE (HMF200)
W485-0034	SECONDARY AIR TUBE COTTER PIN
W485-0047	HAIR PIN COTTER PIN
W010-3025	FAN LIMIT SWITCH - WOOD
W010-3026	FAN LIMIT SWITCH - OIL
W707-0015	TRANSFORMER, 120V/24V 40VA
W660-0149	FAN/LIMIT RELAY SPDT 120V COIL 90-294Q
W660-0150	TRANSFORMER RELAY SPNO 24V COIL 90-360
W435-0014	BLOWER MOTOR CAPACITOR
W435-0030	BLOWER MOTOR
W085-0001	BRUSH, 5" POLY SWEEP 3/8" NSPM
W085-0002	BRUSH ROD, 1.5m FIBERGLASS EXT 3/8" NSPM
62140	GEAR, SPLIT LEATHER GLOVE
W585-0782	SHIELD, SS AIR WASH HEAT (HMF150)
W585-0776	SHIELD, SS AIR WASH HEAT (HMF200)
W290-0216	GASKET, AIR WASH
W080-1275	BRACKET, SS AIR WASH
W570-0007	SCREW, 1/4"-20 x 3/8" HEX HD

NOTE: • See Section 9.4 for firebrick placement.
• Firebrick's "M" to "W" for HMF200 only.

11.0 TROUBLE SHOOTING GUIDE

! WARNING
TURN OFF THE ELECTRICAL POWER BEFORE SERVICING THE APPLIANCE.
APPLIANCE MAY BE HOT, DO NOT SERVICE UNTIL APPLIANCE HAS COOLED.
DO NOT USE ABRASIVE CLEANERS.

SYMPTOM	PROBLEM	TEST SOLUTION
Smoke enters the room during start-up.	Cold air blockage in chimney.	- Burn a piece of newspaper to establish a draft.
	Close the doors.	- If the flame is not getting enough air, first make sure the air control is open. If additional air is needed, open the doors a small crack only.
Kindling does not start - fire smolders.	Cold air blockage in chimney.	- Burn a piece of newspaper to establish a draft.
	Not enough starter paper.	- Use additional newspaper if necessary.
	Not enough air.	- First make sure the air control is fully open. If additional air is needed, a small crack in the doors is all that is needed.
Smoke enters the room while re-loading.	Insufficient draft.	- Chimney height and outside conditions can negatively affect draft. In these cases a small amount of smoke may enter the home. Adding more pipe or a draft-inducing cap may help.
Appliance does not burn hot enough.	Wood is wet.	- See the section on "Selecting Wood" for details.
	Insufficient draft.	- Chimney height and outside conditions can negatively affect draft. In these cases a small amount of smoke may enter the home. Adding more pipe or a draft-inducing cap may help.
	Primary air control is not functioning.	- With the electric power confirmed to the furnace and the thermostat turned up full, check that the control arm is at bottom of slot in the primary air control housing. - If the arm is not near the bottom of the slot, the primary shutter may be stuck or the motor is malfunctioning.
Blower does not run.	Appliance is not up to temperature.	- This is normal. The blower will come on when the furnace supply plenum is heated up enough to turn on fan limit.
	Electricity is cut to the blower.	- Check the household breaker or fuse to make sure it is operable.
Appliances does not burn overnight.	The doors are not sealing.	- See the section "Door Glass / Gasket Replacement" for details. - Demand from thermostat constantly exceeding output of the furnace. - Primary air shutter always in the full open position.
Appliance smoking.		- Has the chimney had time to get hot? - Is there adequate supply of combustion air? - Is the outside air damper opened? - Is the smoke passage blocked anywhere in the appliance or chimney? - Is the smoke flow impeded by too long of a horizontal pipe or too many bends? - Is it a weak draft perhaps caused by a leaky chimney, a cold outside chimney, too short a chimney, or a chimney too close to a tress or a higher roof?

12.0 WARRANTY

EN

NAPOLEON products are manufactured under the strict Standard of the world recognized ISO 9001 : 2008 Quality Assurance Certificate.

NAPOLEON products are designed with superior components and materials, assembled by trained craftsmen who take great pride in their work. The complete appliance is again thoroughly inspected by a qualified technician before packaging to ensure that you, the customer, receives the quality product that you expect from NAPOLEON.

NAPOLEON BIOMASS FURNACE PRESIDENT'S LIFETIME LIMITED WARRANTY

The following materials and workmanship in your new NAPOLEON biomass furnace are warranted against defects for as long as you own the appliance. This covers: weld defects in the combustion chamber and heat exchangers, ceramic glass (thermal breakage only), ash drawer and iron castings.* Perforations caused by metal scalings for a period of five years.

Electrical (110V) components and wearable parts such as blowers, thermal switch, switches, wiring, firebrick, stainless steel baffle retainer, secondary air tubes, and gasketing are covered and NAPOLEON will provide replacement parts free of charge during the first and second year of the limited warranty.*

Labour related to warranty repair is covered free of charge during the first year. Repair work, however, requires the prior approval of an authorized company official. Labour costs to the account of NAPOLEON are based on a predetermined rate schedule and any repair work must be done through an authorized NAPOLEON dealer.

Note that metal scaling is a normal occurrence during the lifetime of the firebox, but is greatly accelerated by the exposure to moisture, over firing and lack of preventative maintenance. Evidence of either of these conditions voids warranty.

Parts such as firebricks, gaskets and baffles should routinely be removed by the operator as part of the regular service and therefore, any warranty replacement of these parts does not qualify for any labour allowances.

* Construction of models vary. Warranty applies only to components included with your specific appliance.

CONDITIONS AND LIMITATIONS

NAPOLEON warrants its products against manufacturing defects to the original purchaser only. Registering your warranty is not necessary. Simply provide your proof of purchase along with the model and serial number to make a warranty claim. NAPOLEON reserves the right to have its representative inspect any product or part thereof prior to honouring any warranty claim. Provided that the purchase was made through an authorized NAPOLEON dealer your appliance is subject to the following conditions and limitations: Warranty coverage begins on the date of original installation.

This factory warranty is non-transferable and may not be extended whatsoever by any of our representatives.

The biomass furnace must be installed by an authorized service technician or contractor. Installation must be done in accordance with the installation instructions included with the product and all local and national building and fire codes.

This limited warranty does not cover damages caused by misuse, lack of maintenance, accident, alterations, abuse or neglect and parts installed from other manufacturers will nullify this warranty. Warranty does not cover installations in commercial or industrial settings.

This limited warranty further does not cover any scratches, dents, corrosion or discoloring caused by excessive heat, abrasive and chemical cleaners nor chipping on porcelain enamel parts, nor any venting components used in the installation of the appliance.

This warranty extends to the repair or replacement of warranted parts which are defective in material or workmanship provided that the product has been operated in accordance with the operation instructions and under normal conditions.

After the first year, with respect to the President's Lifetime Limited Warranty, NAPOLEON may, at its discretion, fully discharge all obligations with respect to this warranty by refunding to the original warranted purchaser the wholesale price of any warranted but defective part(s).

After the first year, NAPOLEON will not be responsible for installation, labour or any other costs or expenses related to the reinstallation of a warranted part, and such expenses are not covered by this warranty.

Notwithstanding any provisions contained in the President's Lifetime Limited Warranty, NAPOLEON's responsibility under this warranty is defined as above and it shall not in any event extend to any incidental, consequential or indirect damages.

This warranty defines the obligations and liability of NAPOLEON with respect to the NAPOLEON biomass furnace and any other warranties expressed or implied with respect to this product, its components or accessories are excluded.

NAPOLEON neither assumes, nor authorizes any third party to assume, on its behalf, any other liabilities with respect to the sale of this product. NAPOLEON will not be responsible for: over-firing, downdrafts, spillage caused by environmental conditions such as rooftops, buildings, nearby trees, hills, mountains, inadequate vents or ventilation, excessive venting configurations, insufficient makeup air, or negative air pressures which may or may not be caused by mechanical systems such as exhaust fans, furnaces, clothes dryers, etc.

Any damages to appliance, combustion chamber, heat exchanger, plated trim or other component due to water, weather damage, long periods of dampness, condensation, damaging chemicals or cleaners will not be the responsibility of NAPOLEON.

All parts replaced under the President's Limited Lifetime Warranty Policy are subject to a single claim.

NAPOLEON will provide replacement parts at a prorated value of the current retail price.

All parts replaced under the warranty will be covered for a period of 90 days from the date of their installation.

The manufacturer may require that defective parts or products be returned or that digital pictures be provided to support the claim. Returned products are to be shipped prepaid to the manufacturer for investigation. If a product is found to be defective, the manufacturer will repair or replace such defect.

Before shipping your appliance or defective components, your dealer must obtain an authorization number. Any merchandise shipped without authorization will be refused and returned to sender.

Shipping costs are not covered under this warranty.

Additional service fees may apply if you are seeking warranty service from a dealer.

Warranty labour allowance is only for the replacement of the warranted part. Travel, diagnostic tests, shipping and other related charges are not covered by this warranty.

ALL SPECIFICATIONS AND DESIGNS ARE SUBJECT TO CHANGE WITHOUT PRIOR NOTICE DUE TO ON-GOING PRODUCT IMPROVEMENTS. NAPOLEON IS A REGISTERED TRADEMARK OF WOLF STEEL LTD. PATENTS U.S. 5.303.693.801 - CAN. 2.073.411, 2.082.915. © WOLF STEEL LTD.

REV. 02.07.12

H2.4

