

This Owner's Manual is provided and hosted by [Appliance Factory Parts](#).



GENERAL DS15P Owner's Manual

[Shop genuine replacement parts for GENERAL DS15P](#)



[Find Your GENERAL Humidifier Parts - Select From 70 Models](#)

----- Manual continues below -----

GeneralAire® Elite Steam Humidifier

Installation & User Manual – Duct Models

Read and Save These Instructions

Before installing or handling the humidifier please carefully read and follow the instructions and safety standards described in this manual and on the labels attached to the Elite Steam Humidifier.

Test water conductivity before installing the Elite Steam Humidifier.



Duct Installation Kit Included (DMNKit)

FORM NO. 25-32; Rev. A

General Filters, Inc.
43800 Grand River Avenue
Novi, MI 48375
(866) 476-5101
www.generalfilters.com

Canadian General Filters, Ltd.
400 Midwest Road
Toronto, ON M1P3A9
(888) 216-9184
www.cgfproducts.com



GENERALAire
Fresh Indoor Air Quality

Before You Start

Test water conductivity.

Check for the following items inside the box:

1. Duct Steam Humidifier
2. Installation manual
3. Mounting template
4. Installation Kit
 - a. Steam nozzle
 - b. 6' Steam hose
 - c. 9' Condensate hose
 - d. Water tube supply kit (10' tubing)
 - e. Water fill connector
 - f. GFX3 Automatic Humidistat
 - g. Ball valve
 - h. Air proving pressure switch
 - i. Hose clamps
 - j. Fasteners

 **IMPORTANT:** Remove the following items prior to installation:

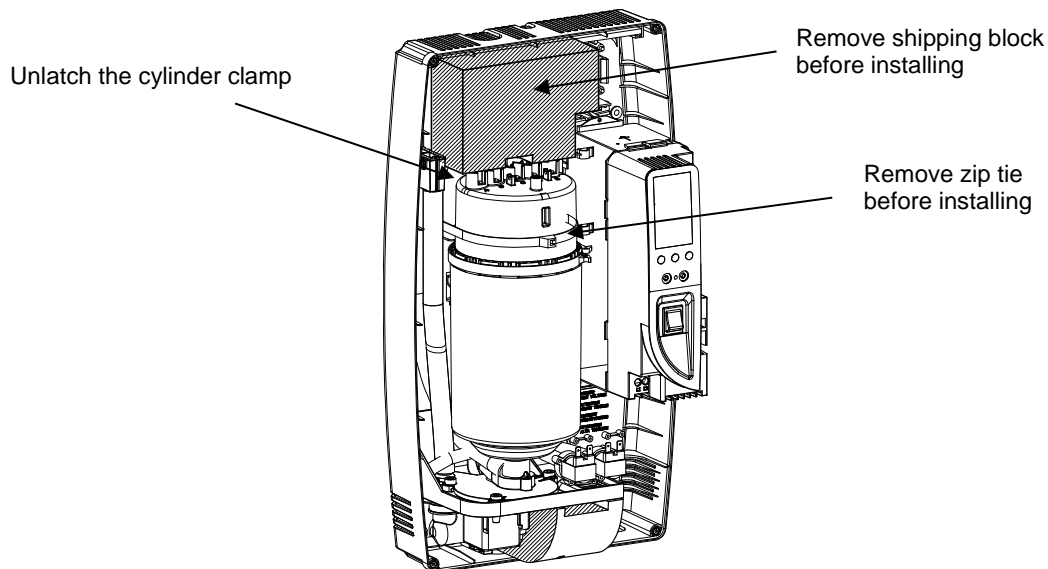

You must be a qualified contractor to install this product.



IMPORTANT WARNINGS

Before installing or handling the humidifier please carefully read and follow the instructions and safety standards described in this manual and on the labels attached to the Elite Steam Humidifier. Test water conductivity prior to model selection or installation.



CAUTION: DISCONNECT THE MAIN POWER BEFORE OPENING OR SERVICING THE HUMIDIFIER!



CAUTION: ELECTRIC SHOCK HAZARD! The humidifier has components that are under power!



CAUTION: SCALDING HAZARD! The humidifier has hot parts (212°F / 100°C).



CAUTION: Your humidifier requires water to operate. **DO NOT** mount it above materials or machinery that could be damaged if a leak occurs. General Filters, Inc. assumes no responsibility for consequential or inconsequential damage as a result of any leaks.



IMPORTANT: DO NOT introduce steam into duct that has interior insulation.



IMPORTANT:

- Install the humidifier out of the reach of children.
- The humidifier must be installed in accordance with all local and national standards.
- All service and/or maintenance operations must be performed by qualified personnel who are aware of the necessary precautions and are capable of performing the operations correctly.
- The conditions of the environment and the power supply voltage must comply with the specified values listed on the data label in the humidifier.
- All other uses and modifications made to the humidifier that are not authorized by the manufacturer are considered incorrect, and the manufacturer assumes no liability for the consequences of any such unauthorized use.



IMPORTANT: Before Beginning Installation:

- Check for shipping damage to cartons. Mark the shipping waybill accordingly.
- Open cartons and check for any hidden damage. Mark the shipping waybill accordingly.
- Check packing slip to ensure all items have been received. Notify General Filters, Inc. of any shortages or damaged parts.

You must notify General Filters, Inc. within 5 working days of any shortages.



IMPORTANT: Disposal of the parts of the humidifier:

- The humidifier is made up of metallic and plastic parts.
- All parts must be disposed of according to the local standards on waste disposal.

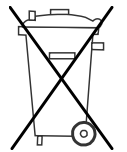

TABLE OF CONTENTS

1. How The Elite Steam Humidifier Works	4
1.1 Basic Operation	4
1.2 Cylinder Life	5
1.3 Calculating Humidity Load	5
2. Models	6
3. Installation	7
3.1 Positioning	7
3.2 Mounting / Unit Dimensions	7
3.2 Fastening to The Wall	8
3.3 Plumbing	9
3.4 Steam Distribution	10
3.4 Installing the Steam Manifold	11
3.2 Correct Manifold Installation Diagram	12
3.5 Power Wiring	13
3.6 Control Wiring	13
3.2 Control Wiring, Cont.	14
3.7 Wiring Connections	15
4. Start-Up	16
4.1 Startup Checklist	16
4.2 The Elite Steam Humidifier Controller	16
4.3 Starting The Elite Steam Humidifier	16
4.4 Starting With A New Cylinder	16
5. Operating The Elite Steam Humidifier	17
5.1 Displaying Information	17
5.2 Selecting Signal Type	17
5.2 Changing The Maximum Production	17
5.3 Activating Manual Drain	17
5.4 Resetting The Hour Counter	18
5.5 Using The GFX3 Humidistat	18
5.6 Alarms	19
6. Trouble Shooting	20
7. Maintenance	21
7.1 Periodic Checks	21
7.2 Cylinder Maintenance	21
7.3 Replacement Parts	22
8. Technical Specifications	23
9. Limited Warranty	24
10. Remote Mount Blower Instructions	26

1. HOW THE ELITE STEAM HUMIDIFIER WORKS

1.1 Basic Operation

The Elite Steam Humidifier is an electrode humidifier. Unlike heating elements, electrode steam humidifiers produce steam for humidification by passing electric current through the water between metal electrodes inside the plastic steam generator cylinder. Steam output is directly proportional to the conductivity of the water and the amount of electrode immersed in the water. Test the water prior to installation with a conductivity tester (use GFI #5539 or CGF #GF-AP-2 or similar).

On a call for humidity, the Elite Steam controller will open the water fill valve (1) and allow water to enter the cylinder. A flow restrictor (4) prevents the unit from filling too quickly or with too much pressure. The water flows up the fill tube (2) and into the fill cup (3). Water then flows over the dam in the fill cup (3), which creates a 1" air gap to prevent backflow of contaminated water into the feed lines, through the fill tube (6) and into the bottom of the steam cylinder (5). Any backflow or overflow of water travels through the overflow hose (13) to the drain.

As the water fills the cylinder, it will reach the electrodes (7) and electrical current will begin to flow. As the water continues to fill the cylinder, the current will increase. This is monitored by an amperage transformer connected to one of the power wires located on the electronic controller. When the desired current is reached, the fill valve will close (1) and the water will then begin to warm and produce steam. If the water reaches the cylinder full probe (9) or if current rises too much, the drain pump (11) will be activated to drain away some water and reduce the current flow to acceptable levels. Note that any time the drain pump is activated, the tempering valve (10) will be opened for tempering the hot drained water down to 140°F / 60°C in accordance to local and national standards (See Figure 1.a.).

Periodically, based on the incoming water conductivity, the unit will activate the drain pump (11) and drain water to reduce mineral concentration. Every 120 hours the unit automatically drains to remove mineral sediment on the bottom of the cylinder. A strainer (12) in the cylinder helps to prevent mineral debris from jamming the drain pump (11).

If the Elite Steam Humidifier remains powered but idle (i.e. without producing steam) for more than 72 hours (3 days), the cylinder will automatically be emptied of water and will not refill until the unit is restarted. If there is no water in the cylinder, there will be no current flow and no steam production.

The electrodes do not burn out, but they will eventually become completely coated with mineral and the cylinder will then need to be replaced. Cleaning cylinders may cause electrode damage, therefore voiding its warranty. See 7.2.2 maintenance section on page 21.

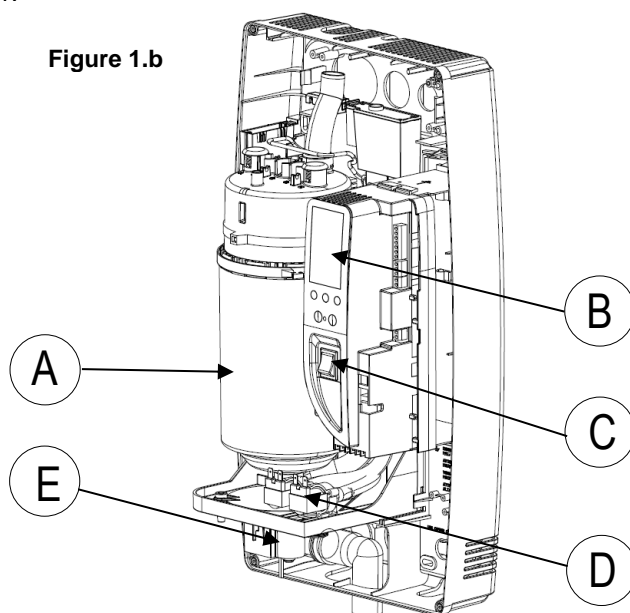
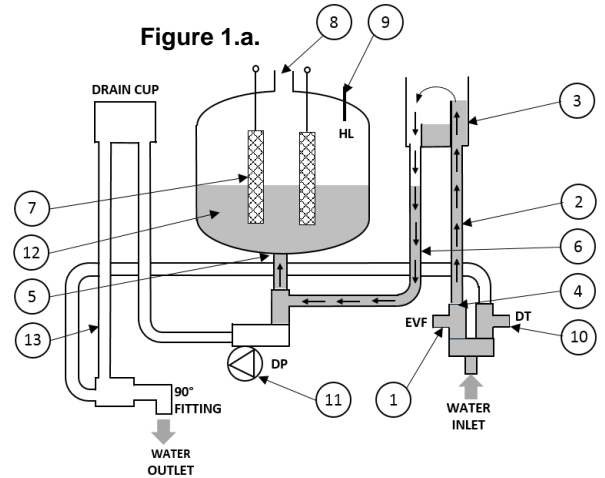

Table 1.a

No.	Description
A	Steam Generator Cylinder
B	User Interface/Display
C	ON/OFF Switch
D	Fill & Tempering Valves
E	Drain Pump

1.2 Cylinder Life

1.2.1 Basics of the Steam Cylinder

The Steam Cylinder is the engine of the humidifier. As the water is evaporated inside the cylinder, minerals are left behind. Much of these minerals are removed through the cylinder drain, however, some are deposited on the walls of the cylinder and the cylinder electrodes. When a lower section of the electrodes develops a thick coating, the water level is raised to expose clean electrode surface. Eventually minerals cover the electrodes' entire length with a thick coating and little electrical current can pass between them, resulting in poor steam output. The humidifier can sense the low amperage and will display the E6 Cylinder Exhausted error code. There are several factors that influence cylinder life:

1.2.2 Water

Water characteristics (mineral percentage and types) influence cylinder life and can vary greatly from place to place. Most water conditions result in flaky scale that eventually fills the bottom of the cylinder until it can no longer function. Water with high silica content can result in a thin glass-like coating on the electrodes that is highly insulating resulting in shorter cylinder life. **Use only cold water. Water conductivity that is not matched to the correct cylinder will shorten cylinder life.**

Water quality affects the operation of this unit, so the Elite Steam should be supplied with water that is **untreated, drinkable, not softened, and not demineralized**. The water converted into steam is automatically replaced through an electric fill valve.

1.2.3 Water Filtration

Typically, additional filtration of the incoming water supply is not necessary. If, however, mineral content is known to reduce cylinder life excessively or if cylinder life proves insufficient then water filtration can be added. In most cases the addition of a two-element water filter can improve cylinder life. The filter should contain an activated carbon element and a particulate filter element rated for about 5 microns or less (micron is a size measurement). The filter system should have a flow rate of at least 2 GPM. The activated carbon will absorb much of the mineral content while the particulate filter will catch any granular material or sediment. It is important to remember that an increase in cylinder life will be accompanied by the need to replace filter elements with each cylinder change. See <https://www.generalfilters.com> for a list of suitable particulate filters.

1.2.4 Humidity Load and Cylinder Life

Humidity load demands have an effect on cylinder life. Normal installations where humidity capacity is properly sized require only intermittent periods where full humidifier capacity is required. This allows the water level in the cylinder to be increased only as electrode segments become insulated; thus extending cylinder life.

Installations that require constant operation at full capacity will reduce cylinder life. The water level in the cylinder is, on average, much higher and the electrodes become completely insulated more quickly.

The importance of providing adequate humidifier capacity should not be underestimated.

1.2.5 Maximum Production

Another factor affecting cylinder life is the maximum production setting. A higher production rate will result in a shorter cylinder life (See Figure 1.c.).

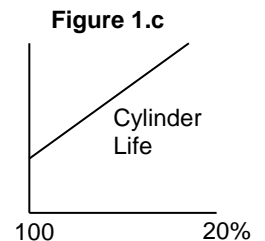

1.2.6 Structures Under Construction

In high-end construction projects, humidification is often required while the structure is being finished. Humidification is necessary to protect and stabilize wood floors, trim and decoration. Humidification load, however, in an unfinished structure may be five to eight times higher than when finished. Elite Steam humidifiers may be operated while construction is underway, but reduced cylinder life is to be expected and budgeted for. **Good practice dictates that the steam cylinder also be replaced once the project is complete.**

1.3 Calculating Humidity Load

1.3.1 Steps to Determine Humidity Load

Humidity Load Calculation (GPD)

Total Square Footage
x Average Ceiling Height
x Factor (From Table 2.a.)
x 1.05 for each Fireplace
x 2.88 convert to gallons/day
= Gallons per Day

Table 2.a.

Pounds of Moisture / Hour / Cubic Foot *

Indoor Air Temp °F/°C	Indoor RH%			
	35%	40%	45%	50%
68°F/20°C	0.00015	0.00018	0.00021	0.00024
70°F/21°C	0.00017	0.00020	0.00023	0.00026
72°F/22°C	0.00019	0.00022	0.00025	0.00028

* Based on .5 air charges per hour.



2. MODELS



DMNKit
(Included With Duct Steam Humidifiers)



RMB15 / RMB35
(Sold Separately; Optional)

Available Steam Models

GFI #	CGF #	Description	Parts Included
5578	DS15PBU	DS-15P w/drain pump. Standard conductivity. Duct steam injection. 15 gallons/day (5.5 Lbs/hour) 110-120v.	Includes Humidifier and Duct Steam Injection Kit (DMNKit) components: 6 ft. steam hose, nozzle, GFX3 humidistat, code valve, water fill connector, 9 ft. condensate hose, water supply tubing kit, air proving pressure switch kit.
5574	DS25PBU	DS-25P w/drain pump. Standard conductivity. Duct steam injection, 35 gallons/day (12 Lbs/hour) 220-240v.	
5577	DS25LCBU	DS-25PLC w/drain pump. Low conductivity. Duct steam injection, 35 gallons/day (12 Lbs/hour) 220-240v.	

Remote Mount Blower Kits

7665	RMB15R	RMB15 - Remote Mount Blower Kits 120v. For DS15P only.	120V room blower assembly and grille package
7660	RMB35R	RMB35 - Remote Mount Blower Kits 230V. For DS25 or DS25LC only.	230V room blower assembly and grille package

3. INSTALLATION

3.1 Positioning

The Elite Steam Humidifier has been designed for wall mounting and, since it is an electrode steam humidifier, should be placed close to the point where the steam will be used to minimize the steam hose length (and the amount of condensate).

⚠ IMPORTANT: Certain minimum clearances must be maintained around the unit for safety and maintenance.
(See Table 3.a. and Figure 3.a.)

⚠ IMPORTANT: DO NOT introduce steam into duct that has interior insulation.

Figure 3.a.

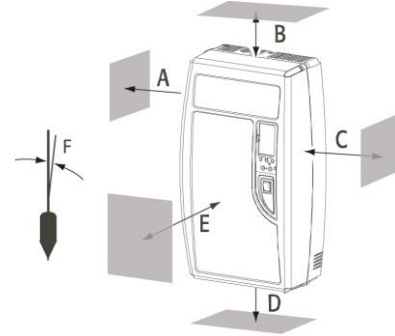

Table 3.a.

	Inch	Millimeters
A	6"	(150 mm)
B	6"	(150 mm)
C	6"	(150 mm)
D	6"	(150 mm)
E	24"	(600 mm)
	max. 0.2°	

3.2 Mounting / Unit Dimensions

3.2.1 Removing the Front Cover

The front cover is secured by four screws located at the four corners of the unit. Use a Phillips head screwdriver to remove the four cover screws. Then simply pull the front cover away from the back part of the unit. Return it in reverse order.

Be careful not to over-tighten the screws.
(See Figure 3.b. and Table 3.b.)

Figure 3.b.

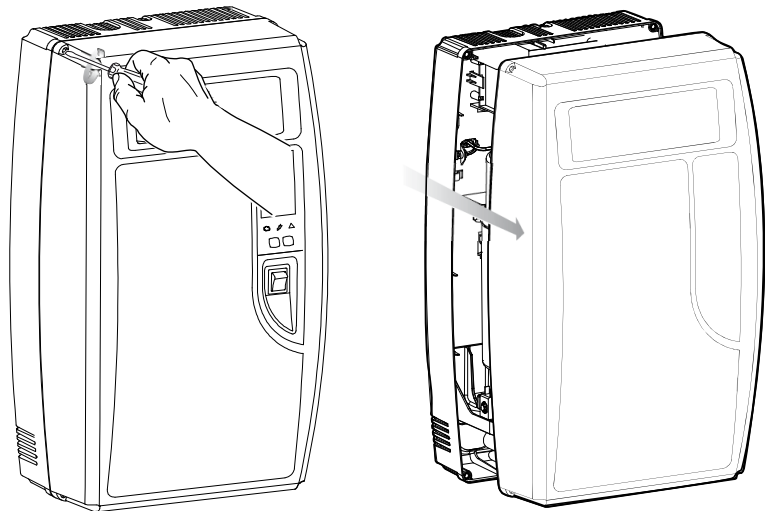
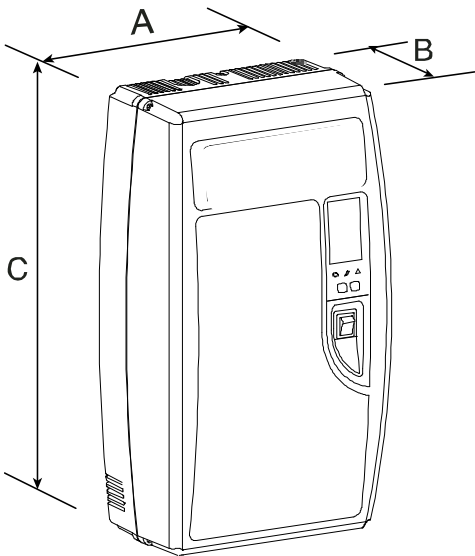

Table 3.b.

Unit Dimensions

	Inch	Millimeters
A	13.5"	341 mm
B	8.1"	204 mm
C	23.7"	600 mm
	Pounds	Kilograms
Weight empty	18 lbs	8kg
Weight packaged	22 lbs	10kg
Weight installed with water	26 lbs	12kg



3.2.2 Fastening to the Wall

Using the supplied template, drill mounting holes (as indicated by "A" in Figure 3.c.) in the wall. Secure the Elite Steam Humidifier firmly to the wall using the supplied screws and anchors.

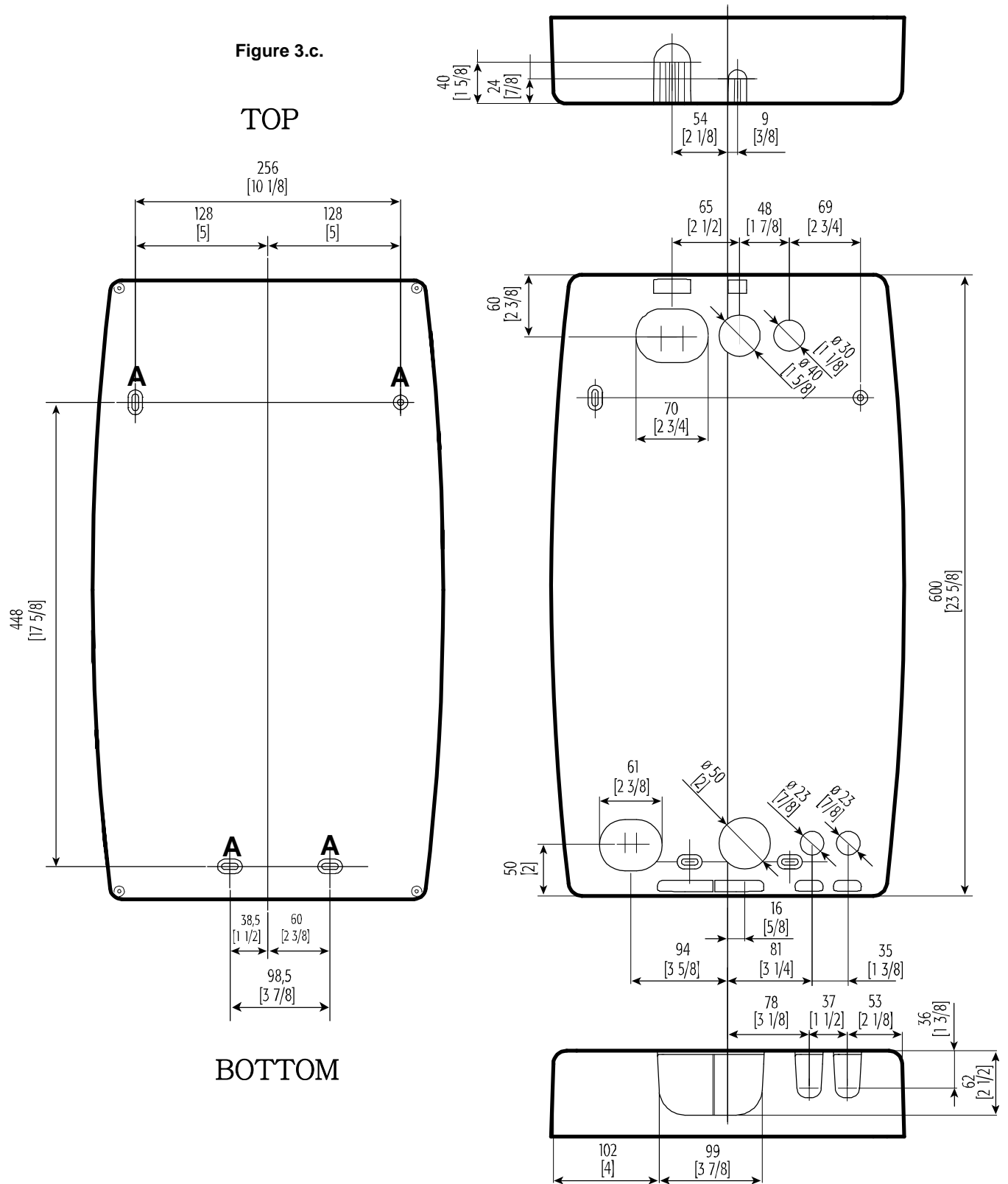

3.3 Plumbing

3.3.1 Water Characteristic Requirements

The humidifier must be supplied with water with the following characteristics:

- Pressure between 20psi and 110psi or 0.1 and 0.8 MPa (1 and 8 bar)
- Temperature between 33°F and 104°F or 1°C and 40°C
- Flow-rate minimum of 0.45 L/min or 0.21gpm
- Hardness no greater than 40°FH (equal to 400 ppm³ of CaCO)
- Conductivity from 125 to 1250 μS/cm
- Absence of organic compounds
- The characteristics of the water of supply must fall within the following limits (Tables 3.c and 3.d):

Table 3.c.
LIMIT VALUES FOR LOW SALT CONTENT WATER

	Units	Min	Max
Hydrogen ions (pH)		7	8.5
Specific conductivity (R,20°C)	μS/cm	300	
Total dissolved solids (c R)	mg/l	(*)	(*)
Dry residue at 180°C	mg/l	(*)	(*)
Total hardness	mg/l CaC ₂ O	150	400
Temporary hardness	mg/l CaC ₂ O	=	200
Iron + Manganese	mg/l Fe + Mn	=	0.2
Chlorides	ppm Cl	=	30
Chlorides	mg/Si ₂ O	=	20
Chlorine residue	mg/l Cl-	=	0.2
Calcium sulphate	mg/l CaS ₄ O	=	100

Table 3.d.
LIMIT VALUES FOR NORMAL WATER

	Units	Min	Max
Hydrogen ions (pH)		7	8.5
Specific conductivity (R,20°C)	μS/cm	125	500
Total dissolved solids (c R)	mg/l	(*)	(*)
Dry residue at 180°C	mg/l	(*)	(*)
Total hardness	mg/l CaC ₂ O	0	200
Temporary hardness	mg/l CaC ₂ O	=	150
Iron + Manganese	mg/l Fe + Mn	=	0.2
Chlorides	ppm Cl	=	20
Chlorides	mg/Si ₂ O	=	20
Chlorine residue	mg/l Cl-	=	0.2
Calcium sulphate	mg/l CaS ₄ O	=	60

(*) Values dependent on the specific conductivity: in general: $cR \sim 0.65 \cdot \sigma R$, 20°C; $R180 \sim 0.9 \cdot \sigma R$, 20°C

Note: There is no relationship between the hardness and conductivity of water.

Water conductivity must be matched by specifications of the steam cylinder. Check or know the water conductivity of the proposed site before installation. Replace the steam cylinder before startup if not correct. (See Table 3.e.)

Table 3.e.

Elite Steam Models	Conductivity μS/cm	Steam Cylinder
DS25LC	125-400	35-15
DS25	400-1250	35-14
DS15P	400-1250	15-14



IMPORTANT: The following water types are not acceptable:

1. Softened water (will lead to foam, electrode corrosion and greatly shortened cylinder life)
2. Water containing disinfectants or corrosion inhibitors (potential irritants)
3. Industrial water, boiler water or water from cooling circuits
4. Any potentially chemically or bacteriologically-contaminated water
5. Heated water

3.3.2 Water Supply Connection

The fill valve and the water supply line should be connected by a soft 1/4" poly hose capable of absorbing water hammering in order to avoid damage to the fill valve. The water line may be routed through the back or through the bottom of the unit. With poly tubing, a tubing support must be used to prevent tubing collapse and leaks. The fitting threads onto the fill valve inlet located on the bottom of the humidifier using a 3/4" G connection (supplied). **Note: As there is a strainer built into the fill valve fitting underneath the unit that requires periodic cleaning, be sure to allow clearance for access** (See Figure 3.d.).

Figure 3.d

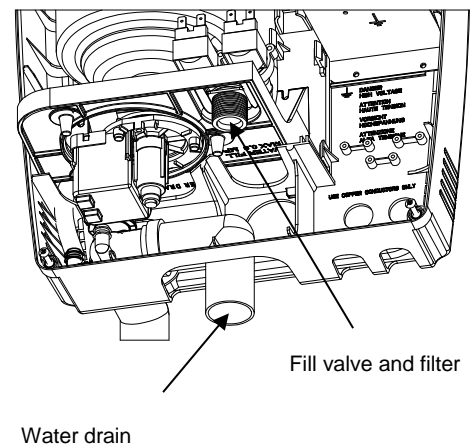

3.3.3 Water Drain

The Elite Steam Humidifier requires a connection to a drain. The drain pipe may be routed out the bottom of the unit using the included grey 90° angle fitting. The drain pipe can be MIN 1-1/2" ID PVC, CPVC or polypropylene. The drain pipe is not glued or otherwise attached to the (supplied) 90° drain elbow, so it must be supported by itself. A coupling (field supplied) should be used. The Elite Steam Humidifier includes a drain tempering valve that runs whenever the drain pump runs and flushes cool water into the drain line to insure the drain water temperature never exceeds 140°F or 60°C. The drain water characteristics are:

- Drain Flow Rate – See Technical Specifications (Section 8)
- Drain Pipe – 1 ½" ID
- Temperature 140°F or 60°C

3.3.4 Drain Pipe

When using a bottom outlet drain, attach the included 90° fitting to the drain outlet. The drain outlet may be rotated.



WARNING: DO NOT connect supplied 90° grey drain elbow directly to drain pipe. The drain pipe must flow freely and without back pressure.

3.3.5 Condensate Pump

When using a Condensate Pump, ensure pump selected is capable of handling 7.0 GPM for up to 10-15 seconds. See <https://www.generalfilters.com> for a list of suitable condensate pumps.

3.4 Steam Distribution

3.4.1 Steam Nozzle Injection (included) (Used when air flow is greater than 1000 CFM)

The maximum allowed duct static pressure is 2 in WC.

The Elite Steam Humidifier duct injection models include a plastic duct injection manifold (See Figure 3.i. and Table 3.f. for associated measurements).

Table 3.f.

	Inches	Millimeters
A	1.24"	31.5 mm
B	1.96"	50 mm
C	2.20"	56 mm
D	2.26"	57.5 mm
E	3.93"	100 mm
F	∅ 0.31"	∅ 8 mm
G	∅ 0.86"	∅ 22 mm
H	∅ 1.18"	∅ 30 mm
I	0.47 or 0.87"	12 or 22 mm

Figure 3.i

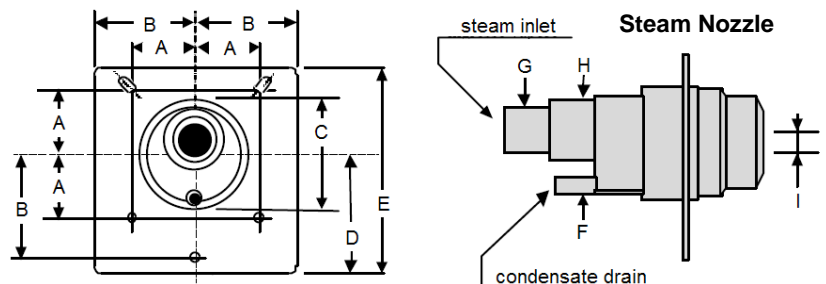
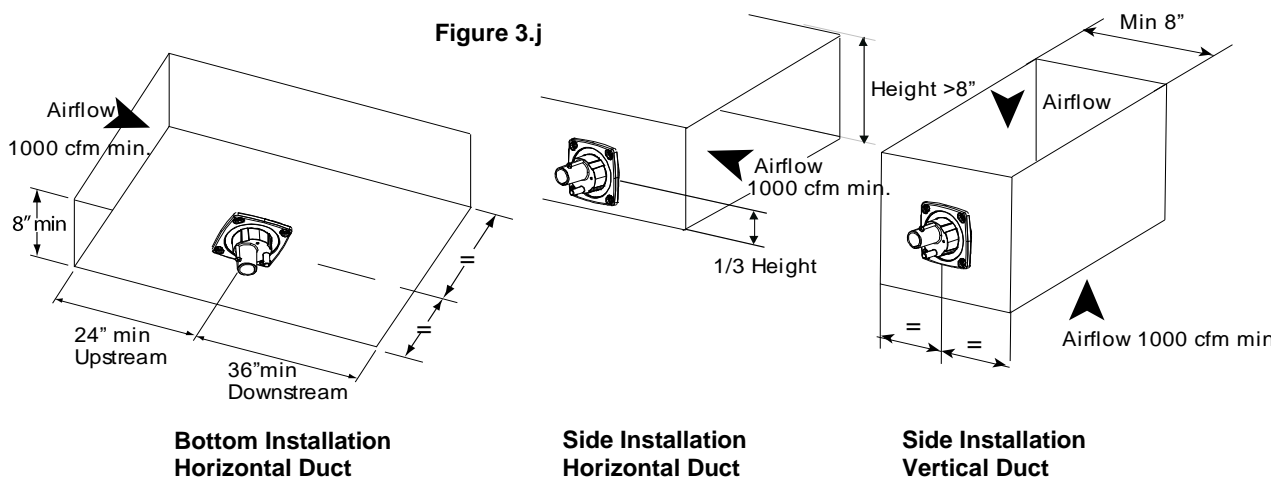

Figure 3.j



Important: DO NOT introduce steam into a duct that has interior insulation.

3.4.2 Steam Manifold Injection (Additional Kit Required) (Used when air flow is between 600 and 1000 CFM.) If a duct steam manifold is to be used, select an accessible location on the duct, allowing at least 36" of straight duct (no elbows or obstructions) after the point where the nozzle/manifold will be installed and the clearances can be maintained as per the following drawings. To mount the steam manifold, cut or drill a 2-1/2" hole in the duct (See Figure 3.j.). Apply caulk to the mounting plate of the manifold. Attach the manifold to the duct using (4) #10 sheet metal screws (supplied). The manifold must be level, or vertical with condensate outlet oriented to the bottom.

IMPORTANT: Allow 5 feet (1-1/2 M) of straight return duct downstream of the distributor pipe or nozzle for absorption of the steam. Always allow 3 feet (0.9M) of straight supply duct upstream of the distributor pipe or nozzle for evaporation of the steam. Turbulent air flow may require longer lengths.

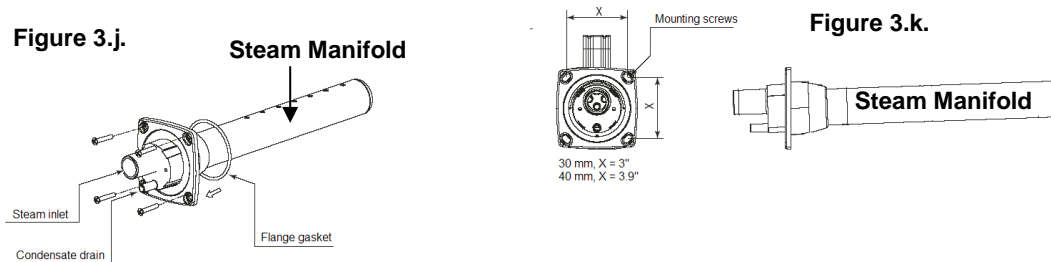

Optional stainless-steel steam manifold
(Canada: GF-DPO30 Kit 12" or GF-DPO45 Kit 17 1/2" / USA: DPO30D22R 12" or DP045D22RO 17.5")

Installing the Steam Nozzle (Section 3. 4.1) or Manifold (Section 3.4.2)

1. Cut a round hole in the side of the duct to match either the nozzle or manifold diameter.
2. Apply silicone sealant to the mounting plate and insert the nozzle or manifold through the hole and secure with sheet metal screws (See Figure 3.k.).
3. Connect the steam and condensate hoses using the hose clamps supplied. (Note: end support bracket supplied only with 36" and longer distributors.)

3.4.3 Return Condensate Connection

The return condensate hose from the nozzle must be trapped. Coil the hose into a vertical loop and secure it below the nozzle. This trap prevents steam from being released into the cabinet. The hose end may be run through the knockout at the top of the humidifier and inserted into the hole located on top of the fill cup. The hole may be enlarged to suit (See Figure 3.l. below).

3.4.4 Steam Hoses

⚠ IMPORTANT WARNING: MOST OPERATIONAL PROBLEMS ARE CREATED BY IMPROPER STEAM PIPING FROM THE HUMIDIFIER UNIT TO THE DUCT DISTRIBUTOR PIPES.

To avoid these problems, remember one simple fact when running the steam hose: steam naturally flows up hill and condensate naturally flows downhill. Run the steam hose or piping to avoid any kinks, sharp elbows, or low spots that could collect or restrict the flow of steam to the distributor pipe, or the flow of condensate back to the humidifier. Support the hose adequately to avoid sags. The following diagrams (See Figure 3.m. on next page) are provided as guidelines. Contact General Filters for unusual installations.

3.4.5 Steam Cylinder Hose Adapter (See Figure 3.l.)

Open sealed bag. FOLLOW INSTRUCTIONS to avoid damaging the black steam adaptor.

1. First slip narrow end of adapter into blue steam hose.
2. Insert the steam adapter with the hose installed into the steam unit through upper hole in the shelf.
3. Insert the red O-ring into large end of black adapter.
4. Slide and lock the fixing bracket to mesh with the 2 slots in the black adapter.
5. Fix the adapter onto the cylinder, then fix the bracket using the supplied screws.
6. Firmly tighten the steam hose clamp (max tightening torque 6Nm – 53 in-lbs.)

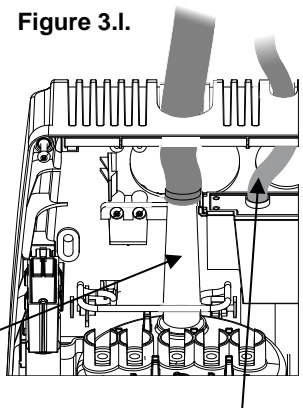

25-12 Steam cylinder
hose adapter

Condensate hose
connector

Figure 3.m.

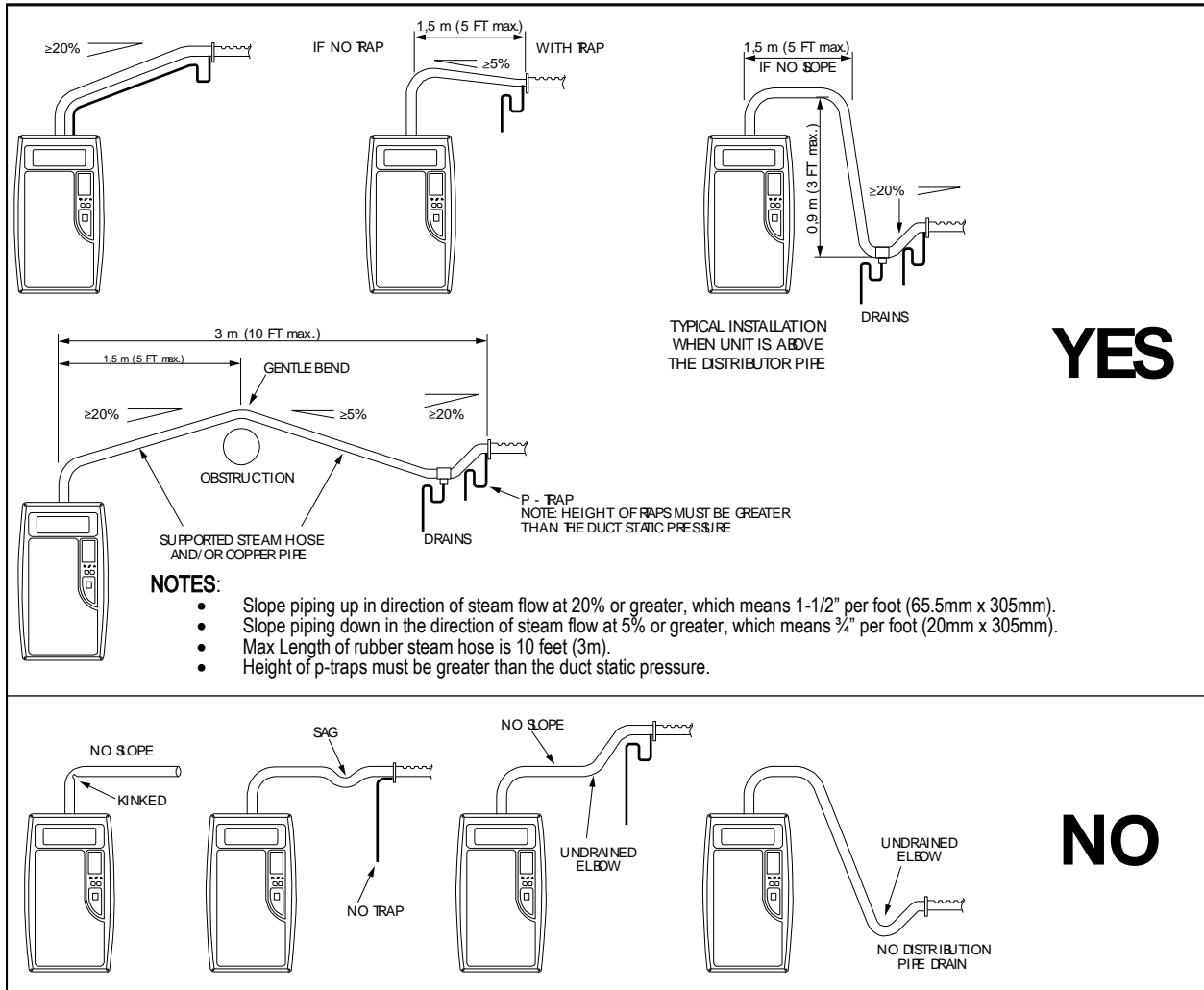

IMPORTANT: The standard steam unit comes with 6 feet (1.8m) of steam hose. Maximum total length of rubber steam hose is 3.65m (12 feet). The maximum total length of insulated copper tubing may be up to 6.1m (20 feet). The maximum combined allowed length of steam hose and insulated copper tubing is 9.75m (32 feet). In all cases, minimize sharp bends and elbows. Use two 45° elbows instead of one 90° elbows. Hose inner diameter 7/8" (22 mm); Hose outer diameter 1 1/4" (30 mm). Additional steam hose is available GFI #7513 / CGF #GF-20-2.

3.4.6. Remote Mount Blower

Refer to Section 10 for detailed Remote Mount Blower Installation Instructions.

3.5 Power Wiring

Figure 3.p.

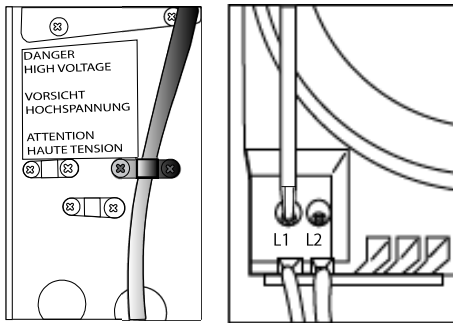

Check that the power supply voltage to be connected matches the value indicated on the rating plate inside the electrical panel.

Insert the power and ground connection cables into the electrical panel compartment using the strain reliefs supplied and connect to the terminals. An external fused disconnect must be installed. (See Figure 3.p.)

All wiring must be in accordance with local, state and national electric codes.

NOTE: to avoid unwanted interference, the power cables should be kept separate from any control wiring.

NOTE: Tolerance allowed on main voltage = - 15% to + 10%.

Figure 3.q.

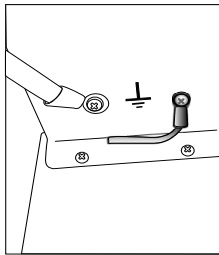

Connect power wires to the power terminal block located at the bottom left of the control module, polarity does not matter. (See Figure 3.p.)

Connect the ground wire to the unit's chassis ground, located just behind the power wiring terminal block. (See Figure 3.q.)

Table 3.h.

Model	Power supply (single phase)	Steam Output (lbs/hr)	Steam Output (kg/h)	POWER (kW)	CURRENT (A)	EXTERNAL POWER WIRES	EXTERNAL FUSE (A) OR BREAKER
DS15	110Vac 50/60Hz	5.5	2.5	1.80	16.40	AWG10	25
DS25/DS25LC	230Vac 50/60Hz	12	5.4	3.89	16.95	AWG10	25

(Since 25A breakers are not readily available in the Canadian market, use a 30A DP breaker.)

3.6 Control Wiring

Figure 3.r.

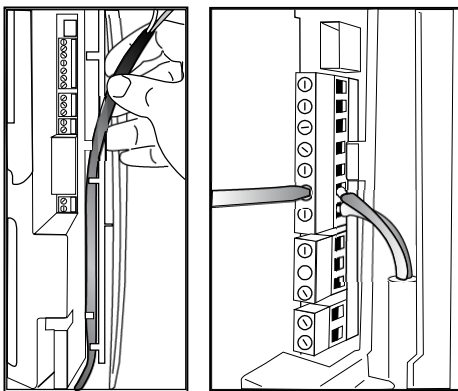

Elite Steam Humidifiers allow for the connection of any simple or automatic humidistat, safety devices such as high-limit humidistat, air flow proving switch, or remote ON/OFF switch (Figure 3.r.).

The humidifier is operated by the closing of a mechanical humidistat H, or by the closing of a voltage-free remote contact, or alternatively by a combination of both. The most common is a combination of a humidistat and pressure switch. The diagrams in the figures below show the connections to be made on the terminal block, in case of:

Figure 3.s. Operation controlled by an external mechanical humidistat

Figure 3.t. Operation performed by a simple enabling contact

Figure 3.u. A combination of both humidistat and pressure switch (most common)

Contact AB-AB:

- Closed: humidifier enabled to produce steam (production starts when humidistat closes).
- Open: steam production is immediately stopped.
- The remote ON/OFF contact is usually a series of external potential-free contacts that enable the humidifier to produce steam when all of them are closed, indicating the duct/AHU is **ready to accept steam. Connect the 12500 Pressure Switch NO and C terminals to the AB-AB contacts.**

For Example:

- Fan contact closes when fan is running.
- Downstream cooling coil contact closes when coil is off; etc.

Contact IN-GND:

- Closed: steam production starts if contact AB-AB is closed.
- Open: steam production is stopped after 5 seconds.

Figure 3.s.

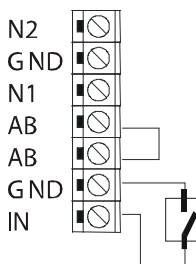

Figure 3.t.

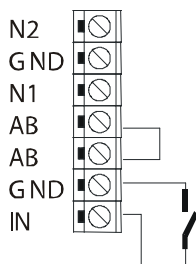
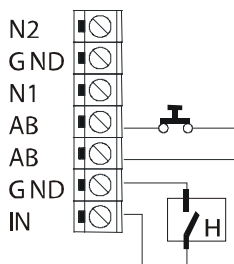

Figure 3.u.



3.6.1 Connect the GFX3 Humidistat for ON/OFF Operation (Figure 3.w.)

1. Remove the humidistat from the base, squeeze the louvered base at the top and bottom. To remove the humidistat from the wall, lift up on the humidistat and pivot top away from wall.
2. Before wall mounting, remove the black foam gasket.
3. Before return air duct mounting, remove the breakout piece.
4. If return air duct mounting, route wires between humidistat and base.
5. Mount the sensor outside the house. Do not mount on south side of the house or in direct sunlight. Place at least 4 feet away from any exhaust vent. If in air intake, place 1 foot or closer to outside wall. Place at least 6" higher than possible snow. Do not route sensor wire near high voltage wires.
6. Connect the GND-IN terminals on the humidifier to the HUM terminals on the GFX3 Humidistat. Connect the GND-24V terminals to the ACL-ACN terminals on the GFX3 Humidistat (See Figure 3.w.).

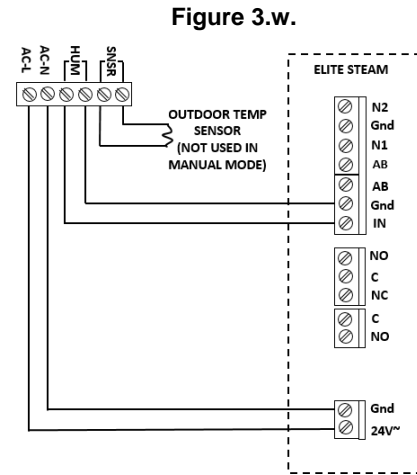

Figure 3.w.

3.6.2 Modulating Operation

Connect an external 0 to 10 VDC modulating input between terminals IN-GND. Connect any Safety Switches (high-limit, air flow switch, remote ON/OFF) in series to terminals AB-AB. If no safety switches are used, then a jumper must be installed between AB-AB. **DO NOT apply any voltage to AB-AB.**

3.6.3 Connect the GFX50 Humidistat for Modulating Operation (Figure 3.x.)

To select signal modulating (See Figure 3.x.) Connect the power supply to the GFX50 G and G O terminals, using the terminal GND and 24V on the Elite Steam. **Note MODULATING OPERATION requires a change in signal type.** (See section 5.1.1 page 17.) Connect an external signal to the GFX50 using the terminal IN from the Elite Steam and AOUT in GFX50. (See Figure 3.x.)

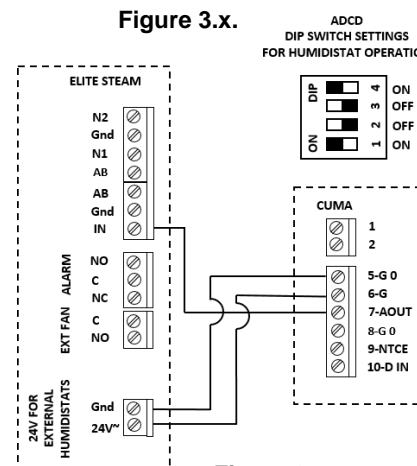

Figure 3.x.

3.6.4 Safety and High Limit Switches (Field Supplied) (Figure 3.v)

Highly Recommended. Remove the jumper between terminals AB-AB and connect any simple high-limits air flow switch (suggest part HC-201; GFI #7520 or similar); a pressure switch (suggest part 12500; GFI #7021 or similar), and remote contacts in series to terminals AB-AB; otherwise, if no such dry contacts are available, the jumper must remain in place between terminals AB-AB. **DO NOT apply any voltage to AB-AB.** thread the control wiring through the bottom of the unit, and the strain relief (see photo at top of previous page), and then up the side of the control module to the top right wiring terminal blocks. Connect the control wiring to the control wiring terminal blocks found at the top right side of the control module. (See Figure 3.v.)

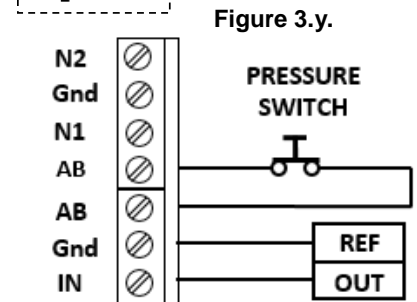

Figure 3.y.

3.6.5 Furnace Blower Operation / Air Conditioner Relay Interlock (Figure 3.y.)

Auxiliary DPDT safety relay: Use this method in the following situations:

1. To prevent the air conditioner from running when there is a call for humidity. The DPDT relay will open the "Y" circuit and close the "G" circuit for operation while a call for humidity is present (See Figure 3.y.). The demand for humidity will override the call for cooling.
2. In systems using a thermostat where G and Y are a single circuit, the DPDT relay will allow blower operation to occur without back-feeding the compressor. **DO NOT use this method when simultaneous humidification and cooling will be desired.** Use a high limit humidistat in to avoid condensation in ductwork. The humidistat should be set to OFF during the air conditioning season if humidification is not desired.
3. For homes without an air conditioner, see Figure 3.z.
4. For variable speed or DC systems, consult the furnace manufacturer.

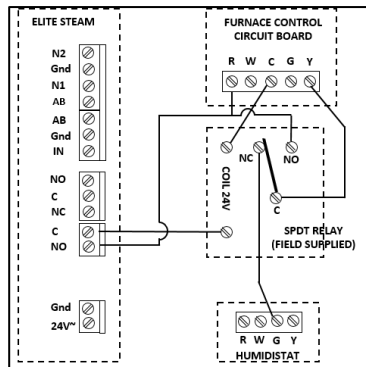

Figure 3.z.

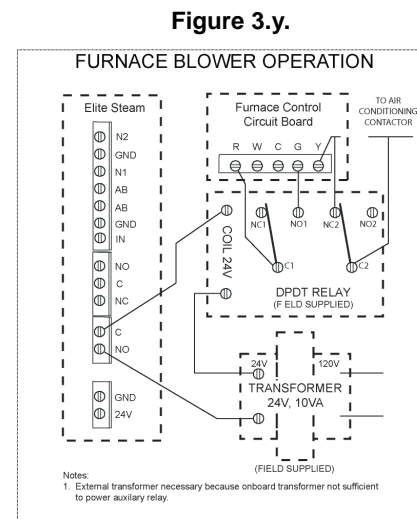

Figure 3.y.

Notes:
1. External transformer necessary because onboard transformer not sufficient to power auxiliary relay.

3.7 Wiring Connections

Terminals	Functions	Electrical specifications
L1-L2 -GROUND	Power supply and ground connections	Power supply 110 VAC 1-phase 50-60Hz 1.86kW or 230 VAC 1-phase 50-60Hz 4.05kW
KEY	Programming port	Connecting to programming port or supervisor
AB-AB	Remote enabling input	Imposes an external NO contact; Rmax=300 Ohm; Vmax=33 Vdc; Imax=6mAdc; humidifier enabled = contact closed
IN-GND	Humidistat control signal input	If programmed 0...10V: Input impedance 10 kohm
		If programmed ON-OFF: Vmax 33Vdc Imax = 5mA Rmax = 300 Ohm
NC-C-NO	NC alarm contact Common alarm contact NO alarm contact	250V; 8 Amp max with resistive load; 4 Amp max with inductive load
NO-C	External fan relay (furnace blower)	250VAC; 8 Amp max with resistive load; 4 Amp max with inductive load
24GND	Power for external humidistat	Power supply for external humidistat 24 VAC; 2 Watt
F – INT FAN	For Remote Mount Blower	For optional RMB only, not for furnace or air handler connections

3.7.1 Wiring Diagram of Controller

Always use AWG10 wires and dedicated 25A or 30A breaker for power supply connections to L1 / 2 above.

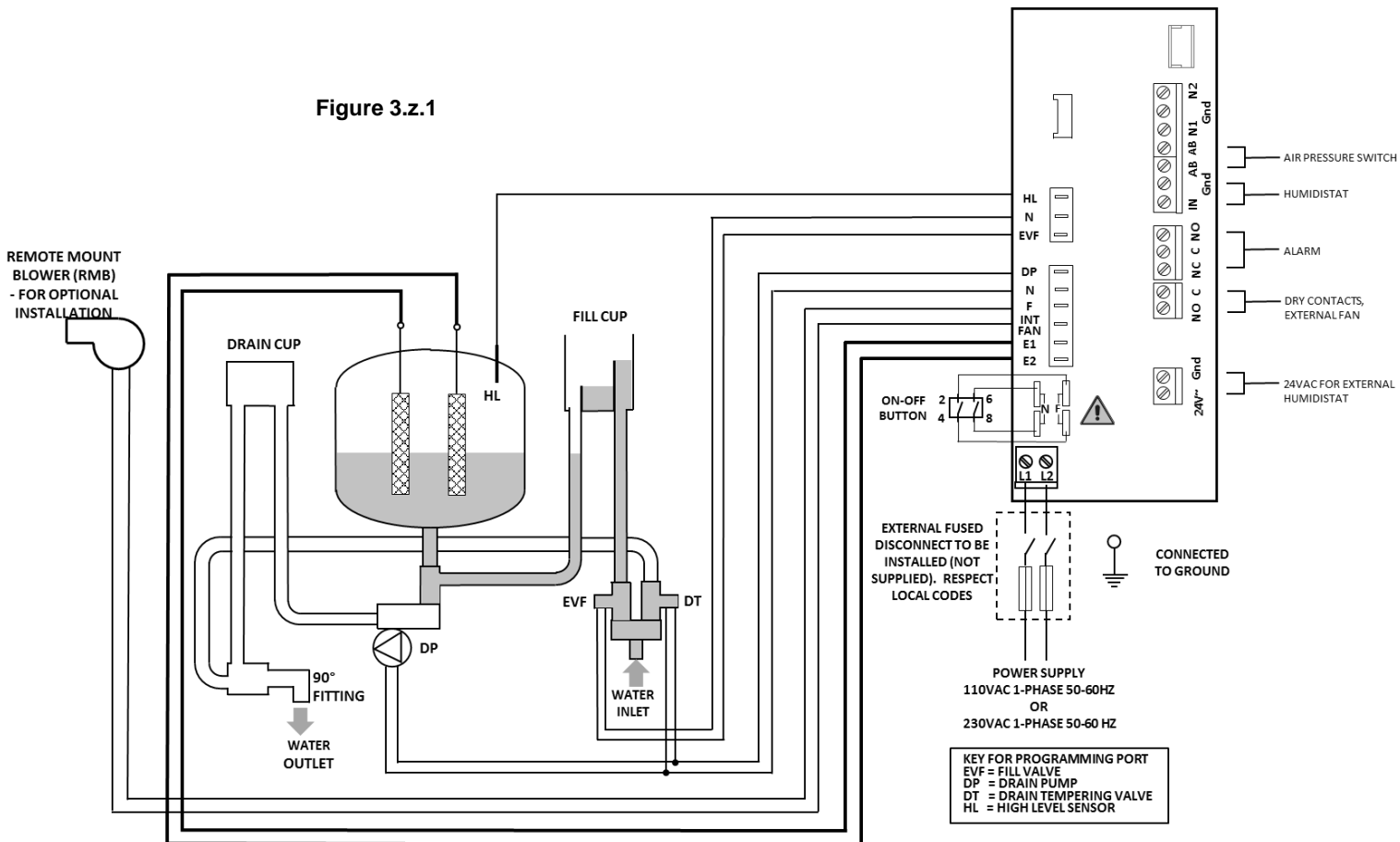

4. START-UP

1. Before starting, check that there are no water leaks and that the electrical components are dry.
2. **DO NOT connect power if the humidifier is damaged or even partially wet!**

When installation is completed, flush the supply pipe for 10 minutes by piping water directly into the drain without sending it into the humidifier. This will eliminate any scale or residue that may cause foam when boiling.

4.1 Start-Up Checklist

Before starting the humidifier, the following should be checked:

- Water is connected, the line has been flushed, and external valves are open.
- Min 1-1/2" ID drain is installed, but not connected to 90° elbow (supplied), run to an open drain, and has a trap under the unit.
- Electricity is connected in accordance with instructions, local codes and data labels in the unit.
- The 25 or 30A power fuses are installed and intact.
- All AWG10 control wiring is done and tested.
- The airflow switch is wired to open on air flow loss.
- The Hi-limit humidistat is wired to open on humidity rise above set point.
- Remove two screws securing control board. Unit wires should be checked to make sure they and all connectors are tight.
- The steam hose(s) are run correctly with no sags or kinks and sloped properly according to the manual.
- Condensate hose(s) are run correctly with no sags or kinks and sloped properly according to the manual.

4.2 The Elite Steam Humidifier Controller

The Elite Steam Humidifier Controller features a comprehensive information display that shows the operation of the system at a glance:

1.	Display is % of nominal capacity
2.	Maintenance
3.	Display is amperage (default)
4.	Steam is being produced
5.	Cylinder filling
6.	Foaming
7.	Water presence inside the cylinder
8.	Cylinder draining
9.	LED's indicate: power (yellow), operation (green) and alarms (red)
10.	Drain button for manual draining of cylinder and confirming parameter values
11.	ON/OFF button
12.	Reset button to reset alarms and access parameters
13.	Level of output: 33%, 66%, 100%
14.	Fan relay is activated (when fan icon on the control module is stationary, not flashing)

The Elite Steam Humidifier is now ready to operate.

4.3 Starting the Elite Steam Humidifier

- Insure that the external power is turned on.
- Push the top part of the ON/OFF button so that the "I" part is in (See #11 at right). The yellow power LED will be lit. The Elite Steam Humidifier is now ready to operate.
- When there is a call for humidity, the Elite Steam Humidifier will close its power relays and send power to the electrodes in the plastic steam generator. The green Operation LED will light, indicating that operation has begun.

4.4 Starting With A New Steam System or Replacement Steam Cylinder

When starting with a new cylinder, you should activate the cylinder cleaning function as follows:

1. Switch the Elite Steam Humidifier off.
2. Press and hold both buttons, "reset" and "drain", and switch the Elite Steam Humidifier back on. When the wrench blinks then release the two buttons.
3. Press and hold "reset" until the display shows 04.



WARNING: DO NOT confirm any value higher than 04. If 05 or higher is displayed, press "reset" until the display goes back to the normal operating mode and restart from step 1.

4. Press "drain" (minimum 1 second): the cleaning starts and the display shows PC.

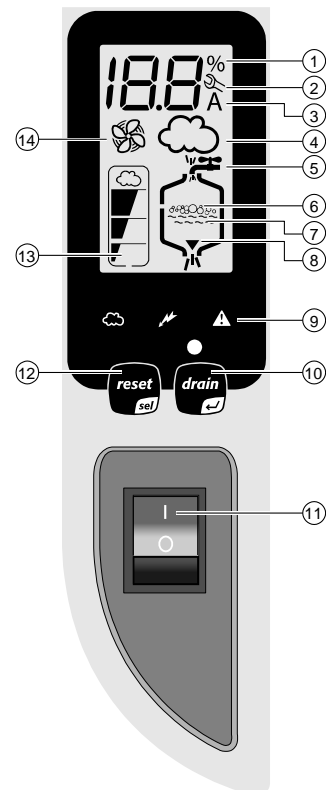

During the cleaning, the electrodes are powered and water in the cylinder rises until it touches the high-level sensor or the phase current equals 20A, whichever occurs first. After either of the events is detected, the boiler is fully discharged with the electrodes un-powered (the drain pump and the drain tempering valve are activated for 3 minutes). General Filters, Inc. recommends performing two cleanings when starting a new boiler. After the cleaning ends, the humidifier begins its regular function. When starting the unit with a new or empty cylinder, it may take a significant amount of time (hours) for the unit to build up enough mineral concentration to reach rated capacity. This time can be shortened by the addition of a teaspoon of salt or ¼ of an antacid tablet through the steam outlet on top of the cylinder.

5. Operating the Elite Steam Humidifier

5.1 Displaying Information

By pressing the “reset” button for 2 seconds, the display will loop from amperage to production in % of the maximum production to the hour counter and back to amperage:

Figure 5.a



1. **Amperage:** it is the value of the current that flows through the water, causing it to boil (default display).
2. **Production %:** it is the current production expressed as a percentage of the humidifier’s capacity.
3. **Hour counter:** expressed in tens; for instance, when the display shows 13 the real hour value will be between 130 and 139 hours.

5.2. Select Signal Type

The Elite Steam Humidifier is pre-set for the included GFX3 humidistat (signal type 0). If the included humidistat is used, this section may be omitted. If another humidistat is used, review this section to see if changes are needed.

1. Switch Elite Steam Humidifier off.
2. Press and hold both buttons “reset” and “drain” and switch the Elite Steam Humidifier back on. When the wrench blinks, release the two buttons.
3. Press “Reset” until the display shows 02. **WARNING: DO NOT confirm any value higher than 04.** If 05 or higher is displayed, press “Reset” until the display goes back to the normal operating mode and restart from step 1.
4. Press “drain” (minimum 1 second) to confirm: the display shows “P1” then the current signal type and “set”.
5. Press “Reset” to change signal type between 0 and 1:
0 = On-Off humidistat such as the GeneralAire “M” or “GFX” series humidistat.
1 = external 0...10 Vdc modulating signal such as the GeneralAire® ADCD series humidistat.
6. Press “drain” (minimum 1 second) when done to confirm the new value of P1 and exit to the normal operating mode.
7. Switch Elite Steam Humidifier off: you can now proceed with connecting the control wiring.

5.3. Changing the Maximum Production

The Maximum Production feature can be adjusted between 20% to 100% of the nominal production in steps of 5% in order to suit the environmental characteristics. DS25 Maximum production is factory set at 70%.



1. Switch Elite Steam Humidifier off.
2. Press both and hold both buttons “Reset” and “Drain” and switch Elite Steam Humidifier back on. When the wrench blinks; release the two buttons.
3. Press “reset” until the display shows 01. **WARNING: DO NOT confirm any value higher than 04.** If 05 or higher is displayed, press “reset” until the display goes back to the normal operating mode and restart from step 1.
4. Press “drain” (minimum 1 second) the display shows “P0” then the current Maximum Production Percent and “set”.
5. Press “reset” to change the Maximum Production in steps of 5% between 20% and 100%.
6. Press and hold “drain” (minimum 1 second) when done to confirm the new Maximum Production and exit to the normal operating mode.

5.4 Activating Manual Drain

Press and hold the “drain” button on the front of the unit until the cylinder is drained. Note: Water will continue to flow from the tempering valve after the cylinder is empty.

5.5 Resetting the Hour Counter With Each New Replacement Cylinder

The hour counter should be reset every time the cylinder is changed in order to reset and restart the internal maintenance timer:

1. Switch the Elite Steam Humidifier off.
2. Press and hold both buttons "Reset" and "Drain" and switch the Elite Steam Humidifier back on. When the wrench  blinks; release buttons.
3. Press and hold "reset" until the display shows 03.  **WARNING: DO NOT confirm any value higher than 04.** If 05 or higher is displayed, press "reset" until the display goes back to the normal operating mode and restart from step 1.
4. Press "drain" (minimum 1 second) to confirm: the hour counter will be reset at once and the Elite Steam Humidifier will go back to the normal operating mode.



5.6 Using the GFX3 Humidistat

Press  to select **OFF**, **AUTO** (if outdoor sensor is connected) or **MANUAL** mode.



OFF mode:

The humidifier is turned off.

MANUAL mode:

The GFX3 will work to maintain the single humidity selected. You can set your desired humidity level by pressing  or . The humidifier will turn ON or OFF according to your manual setting. (The humidifier will operate when the measured relative humidity falls more than 2% below the set point.) Humidity will have to be lowered when weather is colder or if condensation is suspected.

AUTO mode:







The GFX3 will automatically raise the humidity as the outdoor temperature increases. This provides the highest possible humidity. The GFX3 will automatically lower the humidity as temperatures drop. This minimizes the risk of condensation on cold surfaces like windows. You can adjust the Auto Humidity Index Set Point from 0 (low) to 10 (high) by pressing  or . The Humidity Index is based on the outdoor temperature and indoor humidity. The humidifier will switch ON/OFF according to the calculated auto humidity index set point. Lower Index settings are for older homes with less insulation and vapor barriers. Higher Index settings are for newer homes with complete vapor barriers, triple pane windows and high R value insulation. If condensation occurs reduce Index setting by 2 points until condensation stops.

NOTE If the outdoor temperature sensor fails,  flashes and the unit will default to **MANUAL mode**.

To toggle between indoor / outdoor temperature and indoor humidity: Press .

To change the temperature unit: Press °C / °F.

To set the temperature / humidity offset in MANUAL or AUTO mode:

1. Simultaneously press  and  when viewing the temperature or humidity reading.
2. Use  or  to change the setting (-3 to 3).
3. Press  and  simultaneously or wait 5 seconds to confirm, then move onto the next setting.

 **WARNING: DO NOT allow excess humidification.**
Excess humidity can cause condensation and enable mold and mildew growth.

Table 5.a

Suggested Setting	Outdoor Temperatures
15%	-20°F / -29°C
20%	-10°F / -23°C
25%	0°F / -18°C
30%	+10°F / -12°C
35%	+20°F / -7°C
40%	+30°F / -1°C

GFX3 HUMIDISTAT



5.7 Alarms

In the event of an alarm, the red alarm LED will flash, the alarm relay will close, and the alarm code will flash in the display. Multiple alarms will flash in sequence, alternating with the main display. Pressing the “**reset/sel**” button for 2 seconds will reset the alarms, although still active alarms will continue to display.

Display	Description	Action	Red Led	Alarm Relay	Notes
--	Remote on-off open	Unit disabled	Off	Off	
EE	Internal memory error	Unit disabled	On	On	
E0	Control board configuration not valid	Unit disabled	On	On	Turn off, check control board, reprogram
E1	High current alarm	Unit disabled	On	On	Turn off, check connections, check cylinder (no limescale bridges between electrodes, no electrodes short-circuited)
E2	Low production, low supply water conductivity or excessive foam/limescale in the cylinder	Unit disabled Press “ reset/sel ” key for 1 second to reset	On	On	Check supply water conductivity (too low?), replace the cylinder.
E3	Cylinder almost exhausted	Press “ reset/sel ” key for 1 second to reset	Off	Off	Change cylinder (not urgent)
E4	Fill alarm, unable or slow fill (current does not increase within timeout)	Press “ reset/sel ” key for 1 second to reset, otherwise the warning will be reset automatically every 10 minutes until the supply water is available again	On	On	Check water supply and fill valve; check drain pump for leakage
E5	Drain alarm, unable to drain (current does not decrease within timeout)	Press “ reset/sel ” key for 1 second to reset	On	On	Check drain pump and drain connection
E6	Cylinder exhausted (critical performance detected)	The warning is automatically reset if the Elite Steam Humidifier can produce the demand, otherwise turn off and then on	Off	Off	Change cylinder (urgent)
E7	Foam detected	Press “ reset/sel ” key for 1 second to reset	Off	Off	If foam continues, perform additional cleaning cycles (read chap. “Starting With A New Steam System or Replacement Steam Cylinder”)
E8	Cylinder lifetime expired	Unit disabled: reset the hour counter (read chap. “Resetting the Hour Counter”)	On	On	Change the cylinder if necessary
E9	High controller temperature (above 176°F / 80°C)	The warning is automatically reset if the temperature decreases below 176 °F / 80 °C	Off	Off	Check the ambient temperature, replace the controller



6. TROUBLE SHOOTING

Table 6.a

Problem	Causes	Solutions
The humidifier does not turn on	<ol style="list-style-type: none"> 1. No electrical power 2. ON/OFF switch of the humidifier in position 0 (open) 3. Control connectors improperly connected 4. Blown fuses 5. Transformer failure 	<ol style="list-style-type: none"> 1. Check the safety devices upstream from the humidifier and the presence of power 2. Close the switch on the panel: position I 3. Check that connectors are properly inserted in terminal block 4. Check the condition of fuses 5. Check that the proper voltage is connected and turned on
The humidifier does not start operation	<ol style="list-style-type: none"> 1. Remote ON/OFF contact open 2. The humidistat has not been connected correctly 3. Humidistat failure 4. Control signal not compatible with the type set 5. Value measured by the sensor/s higher than the corresponding set point 6. Fan relay not activated, or furnace blower not activated or connected to C/NO on steam humidifier 	<ol style="list-style-type: none"> 1. Close ON/OFF contacts 2. Check the external connection 3. Replace the humidistat 4. Check furnace fan / blower operation
The humidifier fills with water without producing steam	<ol style="list-style-type: none"> 1. High steam back pressure 2. Fill valve strainer clogged 3. Mineral in the fill cup 4. Drain pump valve leaking 	<ol style="list-style-type: none"> 1. Check that the steam hose is not kinked or sagging, trapping condensate 2. Clean the fill valve strainer 3. Clean the fill cup 4. Check for voltage at the drain pump valve and/or drain pump replacement
Excess humidity or moisture in the duct	<ol style="list-style-type: none"> 1. The distributor is not installed correctly (too near the top of the duct or the condensate return is blocked) 2. Air flow rate is too low 3. Humidifier active when the fan in the duct is off 	<ol style="list-style-type: none"> 1. Check that the steam distributor is installed correctly 2. Increase air flow in duct or decrease PO maximum steam production setting 3. Check the connection of the device (flow switch or differential pressure switch) controlling the humidifier to the ventilation in the duct
Water leaks on to the floor below	<ol style="list-style-type: none"> 1. The humidifier drain is blocked 2. The supply water or overflow circuit has leaks 3. The condensate drain pipe does not bring the water back to the drain pan 4. The steam hose is not properly fastened to the cylinder 5. The bushing and / or O-ring at the base of the cylinder are missing or not properly seated 	<ol style="list-style-type: none"> 1. Clean the drain assembly and pan 2. Check the entire water circuit 3. Check the correct position of the condensate drain hose in the drain pan 4. Check the fastening of the hose clamps on the steam outlet 5. Lift out the cylinder and check to see the bushing and / or O-ring are properly seated (See illustration page 21)
Water in the cylinder turns black	<ol style="list-style-type: none"> 1. Minerals in the cylinder have over-concentrated and are deteriorating the electrodes 	<ol style="list-style-type: none"> 1. Check for sags & kinks that could trap condensate in the steam hoses that could cause a back pressure on the cylinder 2. Check the duct static pressure 3. Check the fill valve and inlet strainer 4. Check the drain pump operation 5. Correct installation problems and replace cylinder
Heavy arcing occurs within hours of start-up	<ol style="list-style-type: none"> 1. The feed water contains large amounts of iron, copper or other conductive contaminants 	<ol style="list-style-type: none"> 1. Contact the factory for an optional drain timer to force additional drains to control the minerals 2. Discontinue use if you are using a water softener. 3. Check the electrodes in the cylinder to be sure they were not damaged in shipping
Humidifier continuously fills and drains without producing steam	<ol style="list-style-type: none"> 1. Mineral has bridged between the electrodes. 2. There is back pressure from the steam hoses or duct 3. The flow regulator in the fill valve is broken or out of place 4. Water conductivity is very high 5. Water is foaming excessively 	<ol style="list-style-type: none"> 1. Use instruction in Section 4.4 to power clean or replace the cylinder 2. Check the steam hoses for kinks or gullies that might be trapping condensate 3. Replace the fill valve 4. Consider using a mix of demineralized water with raw water 5. Check cylinder - replace if exhausted. If feed water contains silica or nitrates, install a 1-micron water filter

7. MAINTENANCE

7.0 Periodic Checks

- **After one hour of operation:** Check that there are no significant water leaks.
- **Every fifteen days:** Check operation for water leaks and the general condition of the cylinder. Check that during operation there is no arcing between the electrodes.
- **Every three months:** Check operation for water leaks and, if necessary, replace the cylinder. Check that there are no blackened parts of the cylinder. If there are blackened parts of the cylinder, check the condition of the electrodes and, if necessary, replace the cylinder.
- **Annually:** Replace the cylinder.

CAUTION: ALWAYS disconnect the main power **before** doing maintenance!
CAUTION: ALWAYS disconnect the main power **before** touching the cylinder in the event of leaks, as current may flow through the water.

7.1 Cylinder Maintenance

The life of the cylinder depends on a number of factors, including the amount and type of mineral in the water, the correct use and sizing of the humidifier, and the output, as well as careful and regular maintenance. Another factor affecting cylinder life is maximum production, the higher the production rate the shorter the cylinder life. For this reason, the DS25 & DS25LC are pre-set from the factory at 70%. Further reductions in maximum production will extend cylinder life. (See Figure 7.a)

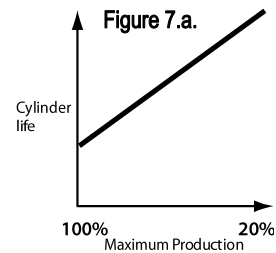

IMPORTANT WARNINGS
 The humidifier and its cylinder contain live electrical components and hot surfaces; therefore, all service and/or maintenance operations must be performed by expert and qualified personnel, who are aware of the necessary precautions. Before performing any operations on the cylinder, check that the humidifier is disconnected from the power supply. Remove the cylinder from the humidifier only after having drained it completely using the manual "drain" button or procedure. Check that the model and the power supply voltage of the new cylinder correspond to the data on the rating label.

7.1.1 Replacing the Cylinder

IMPORTANT WARNING: the cylinder may be hot. Allow it to cool before touching it or use protective gloves.
DO NOT attempt to clean the cylinder. Damage may result that will affect operation and void the warranty.

To Replace the Cylinder:

1. Completely drain the cylinder by pressing and holding the "drain" button until the cylinder is empty.
2. Turn the humidifier off and disconnect the main power.
3. Remove the cover:
 - a. Remove the steam hose from the cylinder.
 - b. Flip up the cylinder holding bracket and lift the cylinder out of the unit.
 - c. Disconnect the steam hose adapter (See Figure 7.b.) from the cylinder and lift the cylinder out of the unit. Bushing and O-ring may fall out with cylinder removal. If so, re-seat a NEW O-ring and existing bushing back in the base.
4. Disconnect the distributor from the cylinder and lift the cylinder out of the unit.
5. Set bushing to side. **DO NOT discard bushing.** DO discard red O-Ring and replace with new.
6. Disconnect the electrical connections from the top of the cylinder.
7. Ensure **NEW** O-ring and bushing are properly re-seated before inserting new cylinder. (See Figure 7.c.)
8. Install the new cylinder in the humidifier by performing the previous operations in reverse.

Steam Hose
Adaptor

Figure 7.b.

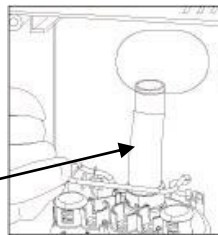
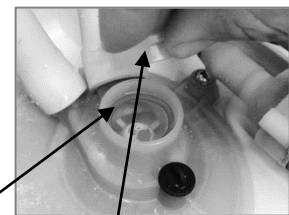

Figure 7.c.

Red O-Ring
AKA: Gasket
REPLACE WITH NEW



White Bushing
KEEP AND RE-SEAT

CAUTION: DO NOT tighten the 7/8" hose clamp so tight that it crushes the cylinder outlet.
WARNING: Electrical connections to the cylinder must be tight or possible fire hazard may result. Threaded nuts on power wires must be connected with 44 in-lbs ± 10% (5 Nm ± 10%).

7.1.2 Maintenance of The Other Plumbing Components

IMPORTANT WARNINGS:

- External power must always be disconnected when performing any maintenance on the humidifier.
- When cleaning the plastic components do not use detergents or solvents.
- Scale can be removed using a solution by using vinegar or a weak solution of acetic acid and a soft brush, then rinse the plumbing components (drain pump, fill/tempering valve, water line fill connector) thoroughly with fresh water.

Cleaning the Fill Valve:

- Disconnect the cables and the hoses, remove the valve and check the condition of the inlet filter; clean if necessary using a cleaning solution and a soft brush.

Cleaning the Drain Pump:

- Remove the valve body, clean if necessary using the same cleaning solution as for the steam cylinder and a soft brush.

Cleaning the Drain Pan:

- Clean the pan of any mineral deposits and check that the water flows freely from the pan to the drain at the drain pump.

Cleaning the Supply, Fill, Overflow Pipes:

- Check that these are clear and clean or replace if necessary. **IMPORTANT WARNING:** after having replaced or checked the plumbing, check that components have been reconnected correctly with the proper seals. Re-start the humidifier and perform a number of cleaning cycles (from 2 to 4, read chap. "Starting With A New Steam System or Replacement Steam Cylinder"). Check for water leaks.

7.2 Replacement Parts

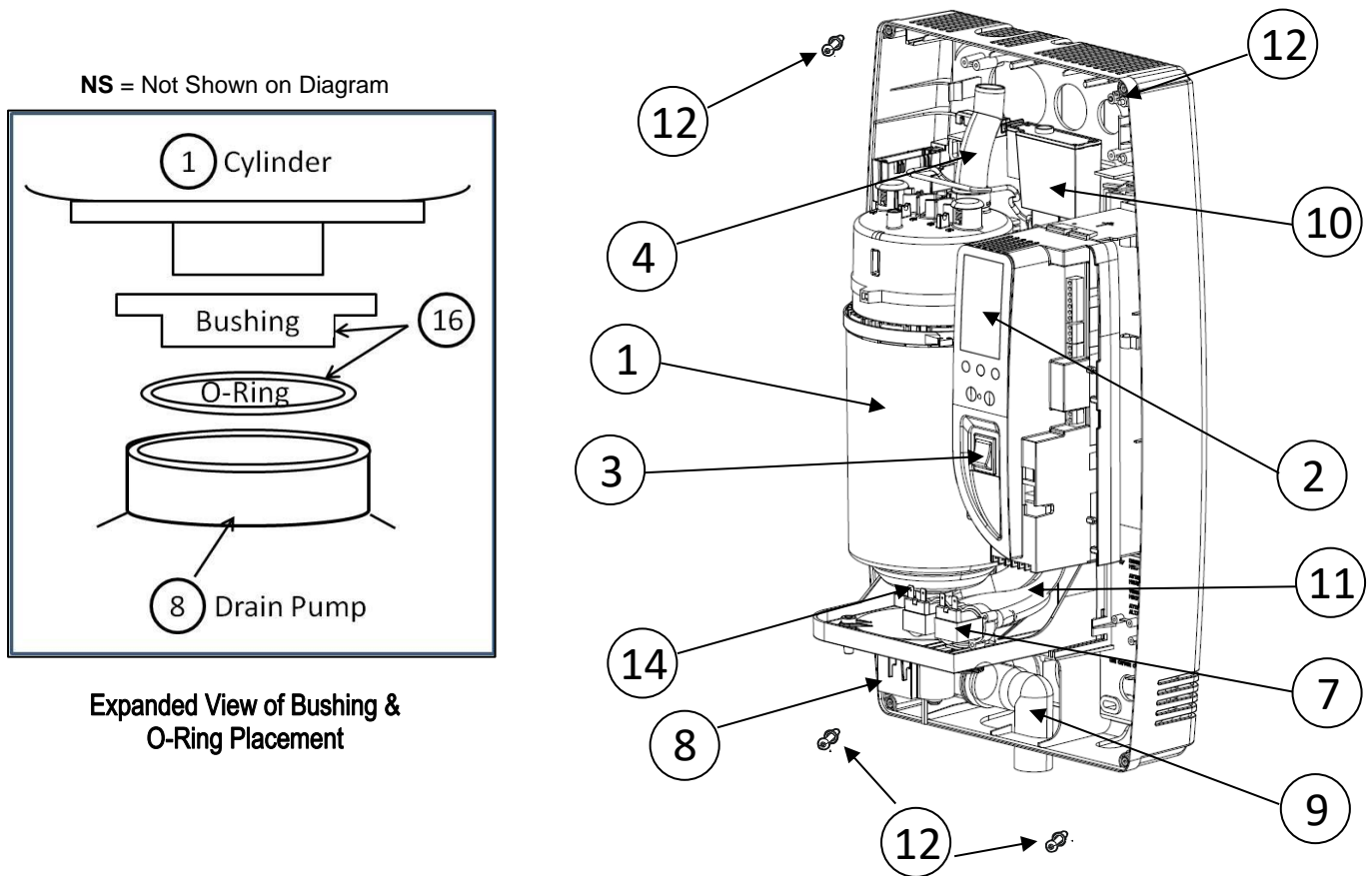

Item	USA GFI Part No.	CANADA CGF Part No.	Description
1			Steam Generator Cylinders
1	7523	GF-15-14	15-14 CYLINDER STD. CONDUCTIVITY 110/1 5.5 LBS/HR - DS15P, DS15
1	7524	GF-35-14	35-14 CYLINDER STD. CONDUCTIVITY 230/1 12 LBS/HR - DS25, DS25LC
1	7543	GF-35-15	35-15 CYLINDER LOW CONDUCTIVITY 230/1 12 LBS/HR - DS25, DS25LC
			Other Replacement Parts
2	7800	GF-25-1	25-1 CONTROL MODULE 5.4 kg/h 230V WITH DRAIN PUMP
	7801	GF-15-5	15-5 CONTROL MODULE 2.5 kg/h 110V WITHN DRAIN PUMP
3	7551	GF-35-18	35-18 ON/OFF SWITCH FOR CH SERIES
4	7815	GF-25-12	25-12 STEAM CYLINDER HOSE ADAPTER
7	7802	GF-15-6	15-6 FILL SOLENOID + DRAIN TEMPERING VALVES 110 V FOR DRAIN PUMP
	7803	GF-25-3	25-3 FILL SOLENOID + DRAIN TEMPERING VALVES 230 V FOR DRAIN PUMP
8	7804	GF-15-7	15-7 KIT FOR DRAIN PUMP 110V
	7805	GF-25-7	25-7 KIT FOR DRAIN PUMP 230V
9	7542	GF-35-21	35-21 90 DEGREE DRAIN ADAPTER FOR CH SERIES
10	7806	GF-25-2	25-2 FILL TANK + PLUG FOR DRAIN PUMP
11	7808	GF-35-25	25-5 DUCT TUBING KIT FOR DRAIN PUMP
12	7553	GF-35-25	35-25 COVER HOLDING SCREWS FOR CH SERIES
14	7809	GF-25-6	25-6 BOTTOM TANK FOR DRAIN PUMP
16	7685	7685	BUSHING KIT FOR DS15 & DS25 ELITE STEAM HUMIDIFIERS (BUSHING & O-RING) (SEE EXPLODED VIEW TOP LEFT)
NS	7810	GF-25-8	25-8 DRAIN TANK + PLUG FOR DRAIN PUMP
NS	7811	GF-25-50	25-50 WIRING KIT FOR UNIT WITH DRAIN PUMP
NS	7552	GF-35-16	35-16 INTERNAL FILTER AND GASKET KIT FOR CYLINDER

NS = Not Showing

8. TECHNICAL SPECIFICATIONS

Steam flows, VAC, kW	5.5 lbs/hr (2.5 kg/h): 110 VAC 1-phase 50-60 Hz, 1.86 kW 12 lbs/hr (5.4 kg/h): 230 VAC 1-phase 50-60 Hz, 4.05 kW	Notes
Steam pressure	3.81 in WC / 950 Pa	For duct only
Dimensions (inches / mm)	24" x 8" x 14" (600 x 204 x 341 mm)	(Height x Depth x Width)
Weight empty/packaged/installed with water (pounds / kilograms)	18 / 22 / 26 lbs. (8 / 10 / 12 kg)	
IP class	IP20	
Electrode power cables	12 AWG	
Power relays (Amps)	2 x 30	On board
Ground connection	Screw	
Input water type	N	No demineralized or softened water
Conductivity range (microSiemens)	125-1250 μ S/cm	Special cylinders for cond. < 350
Water fill connection	1/4" O.D. Compression	Adapter to 3/4" FPS
Water fill - instant flow	0.09 – 0.16 gpm (0.35 – 0.60 l/min)	
Drain pipe (field supplied)	min 1.5" ID drain pipe (38mm)	From bottom of unit
Drain water temp F / C	< 140°F / < 60°C	Drain tempering device
Drain flow	<u>Initial Max drain rate</u> - 7 gpm (26.2 l/min) (w/ full cylinder – for the first 10-15 seconds of drain cycle) <u>Average drain rate</u> – 3.1 gpm (11.7 l/min) (measured over a one minute period starting with full cylinder)	
Serial communication	RS485	
Unit voltages	Primary 120 / 240 Volts AC / Control Wiring 12 Volts DC	
DS15, DS25	Require AWG10 external power wires to electrical panel with a dedicated 25A or 30A breaker	
DS15P	15.8 GPD, preset from factory at 100% production to deliver 11 GPD	
DS25	35 GPD, preset from factory at 70% production to deliver 25 GPD	
Steam hose	ID 7/8" (22mm), OD 1 1/4" (30mm)	
Copper tubing (field supplied)	OD 3/4" to fit ID of blue steam hose	
DMNKit	Includes 6' blue steam hose and 9' black condensate hose	
RMB15; RMB35	Includes room blower assembly and grille package	
GF-12500 air pressure switch	Actuated by positive, negative or differential pressure of .05" W. C. Or more	
Steam nozzle (standard)	Steam nozzle supplied with DMNKit includes 9" of 5/16" black condensate hose	
GF-DPO30KIT (optional)	Optional accessory 12" length distribution manifold	
GF-DP045KIT (optional)	Optional accessory 17-1/2" length distribution manifold	
Inline pre-filter (field supplied)	Any activated carbon element and particulate element rated for 5 micron or less and min 25 GPM	
Condensate pump (field supplied)	SANI-Swift laundry tub pump rated 18 GPDM, 140°F, Little Giant model VCL-45ULS rated at 23 GPM, 140°, Hartell A5	

9. LIMITED WARRANTY

Elite Steam Humidifiers, if properly registered on www.generalfilters.com/support/warranty-registration, are warranted to the consumer against defects in materials and workmanship for a period of five years from the date of installation, so long as the product has been installed by a qualified contractor and operated in accordance with all appropriate manuals and wiring diagrams in a residential structure. (Note: Steam Humidifiers manufactured prior to January 1, 2016 receive a 2-year warranty.)

Installation in commercial, industrial or office building locations will void all warranties. Installation to a water source that does not meet unit specification will void all warranties. Replacement of routinely replaceable parts such as steam cylinders and gaskets, are not covered by this limited warranty or any other warranties.

Any other defective parts will be repaired without charge except for removal, reinstallation and transportation costs. To obtain repair service under this limited warranty, the consumer must send the defective part to General Filters, Inc.

THERE ARE NO EXPRESS WARRANTIES COVERING THIS HUMIDIFIER OTHER THAN AS SET FORTH ABOVE. THE IMPLIED WARRANTIES OF MERCHANTABILITY AND FITNESS FOR A PARTICULAR PURPOSE ARE EXPRESSLY EXCLUDED. THE MANUFACTURER ASSUMES NO LIABILITY IN CONNECTION WITH THE INSTALLATION OR USE OF THIS PRODUCT, EXCEPT AS STATED IN THE LIMITED WARRANTY. THE MANUFACTURER WILL IN NO EVENT BE LIABLE FOR INCIDENTAL OR CONSEQUENTIAL DAMAGES. This limited warranty gives you specific legal rights, and you may also have other rights which vary from state to state. Some states do not allow either limitations on implied warranties, or exclusions from incidental or consequential damages, so the above exclusion and limitation may not apply to you.

Any questions pertaining to this limited warranty should be addressed to General Filters, Inc. General Filters, Inc. has elected not to make available the informal dispute settlement mechanism which is specified in the Magnuson-Moss Warranty Act.

Register your warranty online USA: www.generalfilters.com / Support
Register your warranty online Canada: www.cgfproducts.com / Warranty Registration

GENERAL FILTERS, INC
43800 GRAND RIVER AVENUE
NOVI, MI. 48375
(866) 476-5101
www.generalfilters.com

CANADIAN GENERAL FILTERS, LLC.
400 MIDWEST ROAD
(888) 216-9184
TORONTO, ON M1P3A9
www.cgfproducts.com

10. REMOTE MOUNT BLOWER (RMB) UNIT (OPTIONAL)

10.1 Available Remote Blower (RMB) Models

CGF #RMB35R / GFI #7660 - **230VAC 1~** for use with DS25 and DS25LC
CGF #RMB15R / GFI #7665 - **110VAC 1~** for use with DS15P



10.2 Components Included in the RMB Unit

The RMB unit consists of:

- Housing (includes the fan and distributor);
- Grille (includes the small intake filter);
- 9' of 3/8" ID condensate hose;
- 3/8" x 3/8" barbed hose fitting;
- Small hose clamp.

10.3 Operation

When a demand for humidity is made, the Elite Steam Humidifier will start. The control module will recognize the demand for steam by supplying power to the steam cylinder and the RMB blower. The RMB Blower will run and distribute steam into the room. The RMB grill is designed to blow steam outward and slightly down to avoid condensation on the ceiling. A cleanable filter is located behind the air intake grill to protect the RMB from large particles. When the demand for humidification ends, power to the steam cylinder is stopped. The blower continues to run for 30 seconds to distribute any remaining steam.

10.4 Choosing a Location

Locate the RMB on a wall in the largest open area space to be humidified, allowing humidity to migrate from largest space to smallest space. Do not install the RMB in small, confined rooms or hallways. Keep the steam hose length to a minimum. The RMB must be mounted above the Elite Steam Humidifier since the RMB will create condensate that must drain back to the humidifier by gravity. Remote wall blowers may only be installed in a vertical wall distributing steam horizontally. See Figure 10.a.

NOTES (See Figure 10.a.):

1. The RMB must be installed in the wall and connected to the humidifier with the steam hose supplied.
2. The RMB must be mounted at least 15 inches above the humidifier to achieve 30 degree min slope and avoid condensation/gurgling.
3. Avoid undrained pockets and traps in the hoses. Condensate will accumulate in low areas and prevent steam movement. The steam hose must not have sharp bends or twists.
4. The dimensions in Figure 10.b. are minimum distances to prevent the humidified air from coming in contact with people, electrical equipment, ceilings and cold surfaces before the steam has been completely absorbed. Choose the location with care as the steam is hot and can cause burns.
5. Maximum total length of rubber steam hose is 3.65 m (12 feet). The maximum total length of insulated copper tubing may be up to 6m (20 feet). The maximum combined allowed length of steam hose and insulated copper tubing is 9.75m. In all cases, minimize sharp bends and elbows. Use 2 - 45° elbows instead of 90° elbows. Hose inner diameter 7/8" (22 mm); Hose outer diameter 1 1/4" (30 mm). Additional steam hose is available GFI #7513 / CGF #GF-20-2.

10.4 Wall Opening

The RMB housing will fit in a standard 2x6 wall with ½" drywall.

If installing in a 2x4 wall then the rear drywall must also be removed and the housing will protrude out the back of the wall. Figure 10.c shows the wall opening dimensions for the RMB housing.

Figure 10.a.

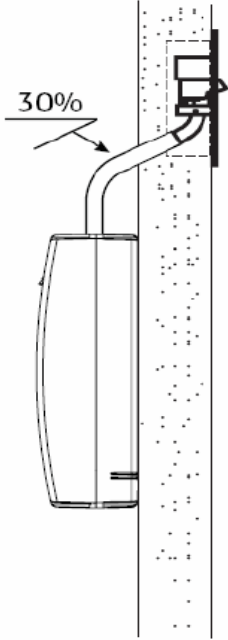
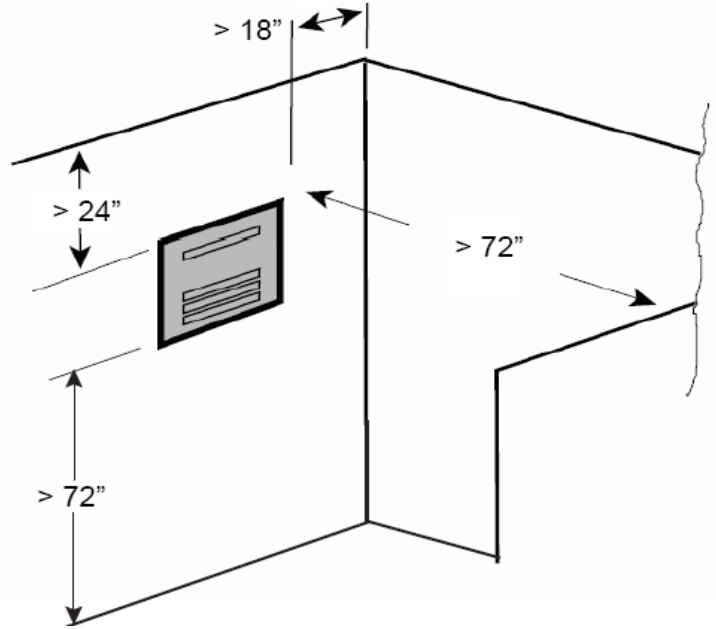

Figure 10.b.



Notes:

1. The RMB housing has flanges on the front that must be mounted on the outside face of the drywall.
2. When installing in new construction, use a piece of return air angle to mark where the RMB unit will go to prevent the drywall from being installed over the location for the RMB housing.

Figure 10.c.

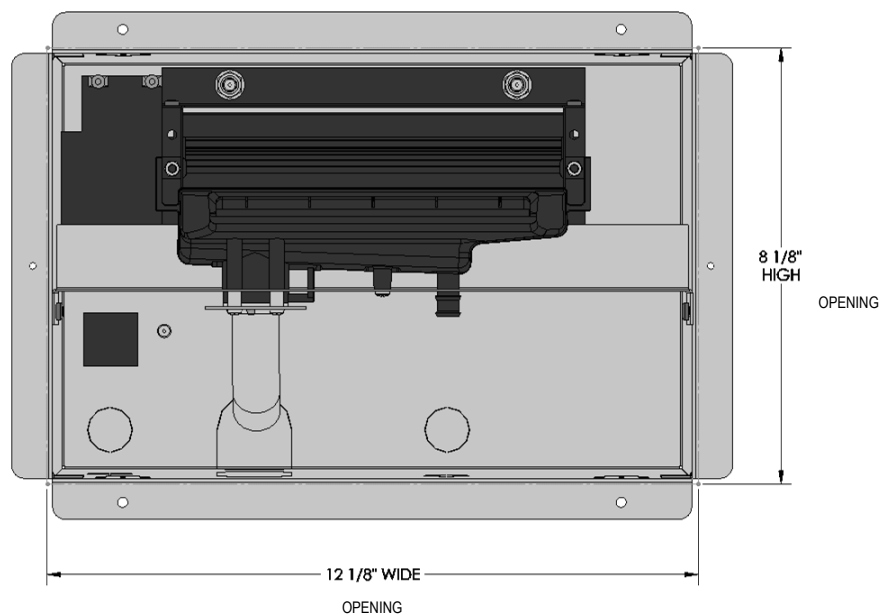

10.5 Housing Knockouts

Determine if the steam will be entering the housing from the back or bottom. Remove the knockouts for the steam hose, condensate hose and electrical connections. (See Figure 10.d.).

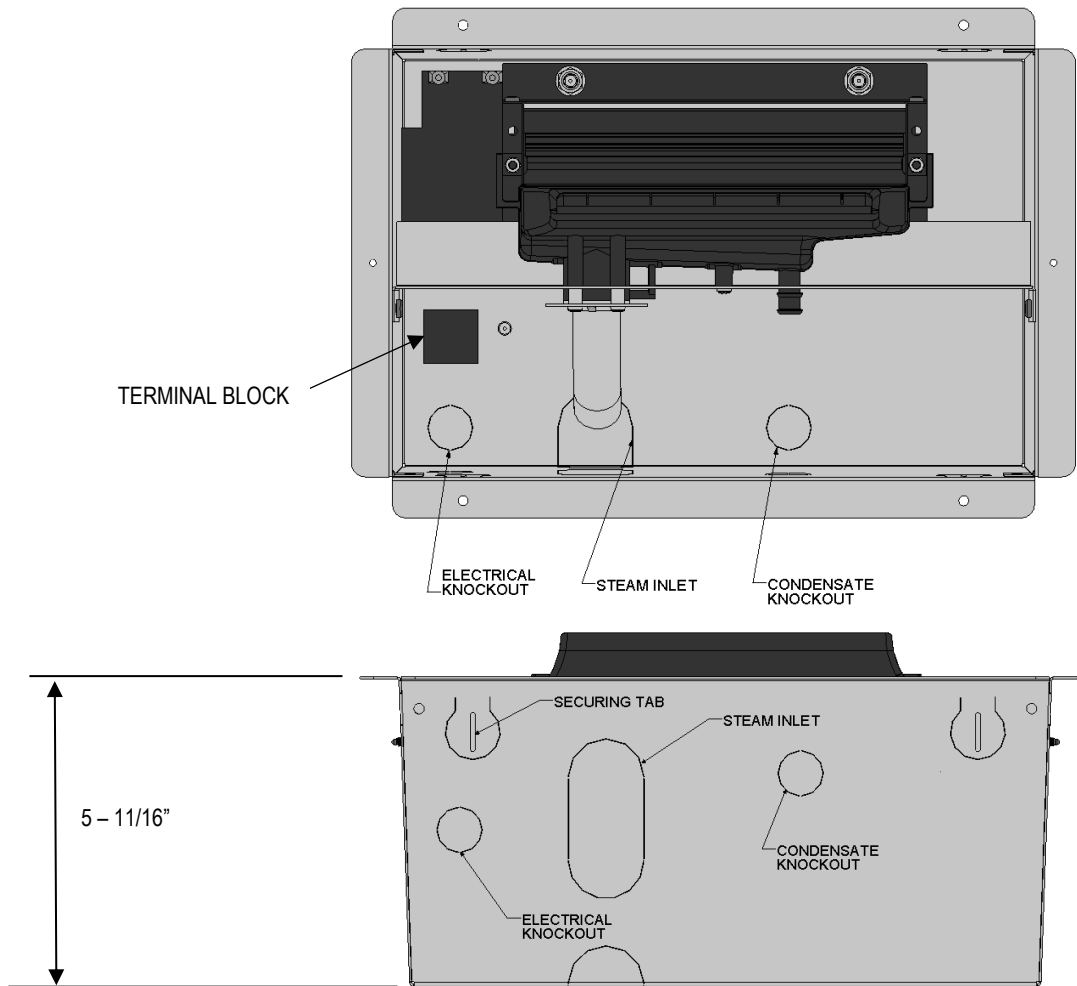

Figure 10.d.

10.6 Installation

Insert RMB housing into the wall and bend the four securing tabs around the back of the drywall. Level the RMB, then secure the RMB housing to the wall using predrilled holes (Figure 6.1) located on the four one-inch flanges of the RMB unit. Use #8 drywall screws (four required) to penetrate the drywall and pass through the slot in the securing tab behind the drywall (See Figure 10.e and 10.f). An alternate installation method is to frame out the opening of the RMB to the dimensions shown in Figure 10.c.

NOTE:

1. The four one-inch flanges on the face of the RMB unit must be on the outside of the drywall. Failure to locate the flanges on the outside face of the drywall may result in water leakage and household damage.

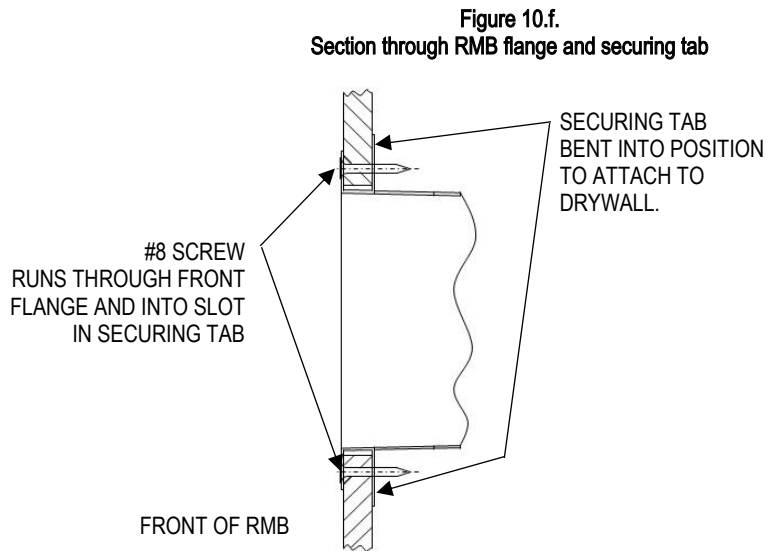
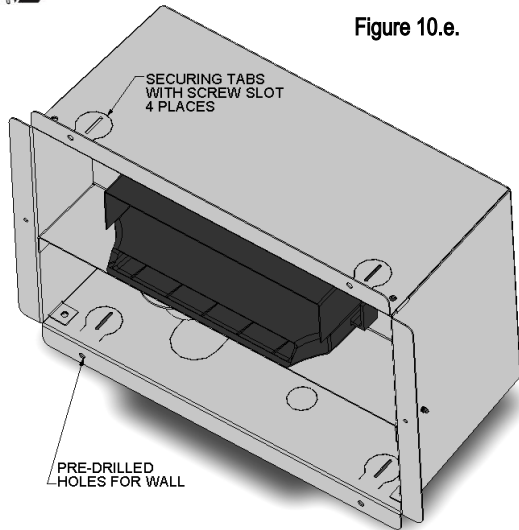

10.7 Electrical Connections

The RMB fan is fitted with a power supply terminal block (Figure 10.c) with two terminals and a ground wire connector on the housing.. The power wire should be 16 gauge or larger shielded cable with ground. Power wiring should be run through the electrical knockout in the RMB and be secured with the supplied cable clamp.

The power will be supplied from the terminals “F” and “INT FAN” located on the back side of the humidifier control module.

The power wire must enter the humidifier through the bottom or back and then be secured inside the humidifier to prevent tension on the wire or connections. To access the wire connection points on the back of the module, remove the steam cylinder. Remove the protective caps on the connection points and use the two supplied spade connectors to make the connections to the F and INT FAN terminals.

NOTE:

1. The power for the RMB unit is from the terminals on the **BACK** of the Control Module!
2. Electrical connections must be performed by qualified personnel in compliance with local codes.

Figure 10.f.

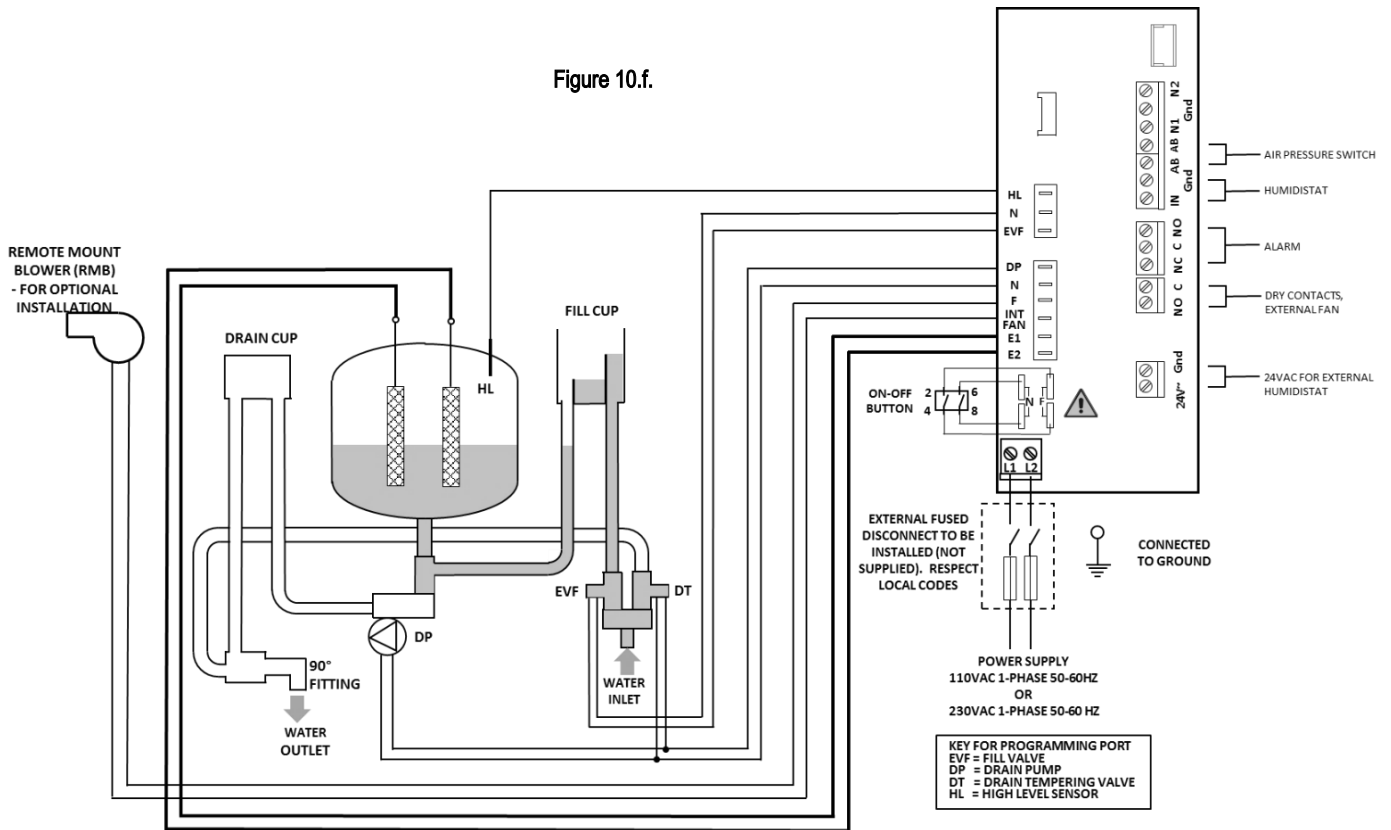

10.8 Hose Routing and Connections

Connect the steam hose to the stainless elbow fitting located at the bottom of the manifold and secure with the hose clamp provided. See Figure 3.m. for additional hose routing recommendations. Do not force the steam hose onto the stainless fitting - apply some water to the inside of the hose and ease the hose onto the fitting. Connect the condensate hose to the molded barbed fitting on the right. (See Figure 10.g) The condensate hose needs to be trapped immediately under the blower housing or directly above the steam humidifier using a 6" loop in the condensate hose.

The 3/8" x 3/8" barbed hose fitting enables the condensate hose to connect to the fill cup. Insert one end of the fitting into the condensate hose (Figure 10.h.), route the hose into the unit through the hole in the enclosure, and then insert the other end of the fitting into the hole on the top of the fill cup (Figure 10.i.).

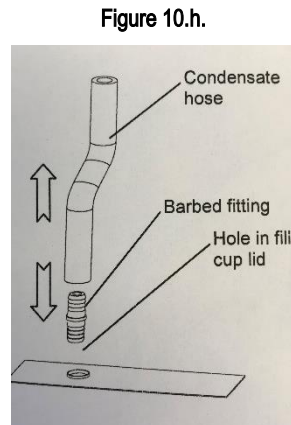
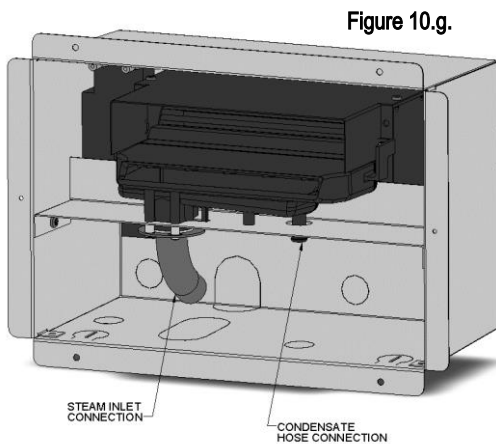

IMPORTANT: The standard steam unit comes with 6 feet (1.8m) of steam hose. The RMB unit comes with 9 feet of 3/8" ID hose. The maximum total length of rubber steam hose is 3.65m (12 feet). The maximum total length of insulated copper tubing may be up to 6.1m (20 feet). The maximum combined allowed length of steam hose and insulated copper tubing is 9.75m (32 feet). In all cases, minimize sharp bends and elbows. Use 2 - 45° elbows instead of 90° elbows. Hose inner diameter 7/8" (22 mm); Hose outer diameter 1 1/4" (30 mm). Additional steam hose is available GFI #7513 / CGF #GF-20-2.

10.9 RMB Grille Installation

Attach the air filter to the grill. Install the grill over the housing face and use the provided screws and pre-drilled holes to secure the grill to the RMB housing. The steam manifold will extend out past the face of the grill. The grill may be painted to match decorations in the home.

NOTE: Use only the grill that was provided with the RMB kit. Any alterations or changes to the grill may result in water leakage and damage to the home.

10.10 RMB Grille Maintenance

The air filter should be vacuumed or rinsed with water at least once per year. More frequent cleaning may be necessary depending on home conditions. Neglecting the air filter (cleaning and/or replacement) will seriously affect the operation of the RMB unit.

NOTE: For new construction, the air filter must be cleaned as needed during construction and again when construction is complete.

10.11 RMB Grille Start-up

The RMB blower will operate when the humidifier has a demand for humidity. Operation will continue for 30 seconds after the demand is complete.

10.12 Technical Specifications

Description	Value or range
Steam output (lb/hr)	0-12
Storage temperature (°C)	-10 to 70
Rated power (W)	24
Rated air flow-rate (cfm)	71
Noise level (open field, at maximum speed, one metre from the front panel) (dB)	30

10.13 Table of Spare Parts

GFI #	Part Number	Description
7545	RMB15	Remote Mount Blower Kit
7540	RMB35	Remote Mount Blower Kit
7534	15-02	Room Blower Assembly 120v for RMB15
7535	35-02	Room Blower Assembly 230V for RMB35
7513	20-2	Steam Hose 7/8" ID
7512	20-3	Condensate Hose 3/8" ID
7559	35-10	Hardware Kit (for RMB15/RMB35)
7536	35-20	Internal Steam Distributor Manifold
7528	35-26	Front Grill (for RMB15/RMB35 - includes filter, labels)
7647	P-241	Steam Hose Clamp #16
7648	P-242	Condensate Hose Clamp #6

About General Filters

Founded in 1936, General Filters, Inc. is a leading manufacturer of premium whole-house, residential fuel oil filters, humidifiers, dehumidifiers, air cleaners, heat / energy ventilators and air purifiers; a complete line of dependable, high quality IAQ and heating solutions for today's energy-efficient homes. GeneralAire® indoor air quality products allow you to Breathe Healthier in the comfort of your own home. Located in Novi, MI GeneralAire® products (under the brand names General, GeneralAire®, Unifilter®, and Gar-Ber) are made in the USA!

How Can Indoor Air Quality Products Help?

Air Cleaners

Quality air cleaners are very effective in removing airborne particulates; particulates that can trigger allergy and asthma symptoms and cause long-term adverse health effects. Air cleaner filters are MERV rated (Minimum Efficiency Reporting Value) with ratings from 1 to 16. The higher the MERV rating, the more effective the filter is at removing smaller and more harmful particulates from the air. Some air filters include carbon-based materials, which act to remove odors from the air inside your home.

Humidifiers

Dry air can have adverse effects not only on your health but your home and its contents. Dry air causes cracks in wood floors, furniture, trim and musical instruments. Dry air can cause static electricity that can damage expensive electronics. Dry air can increase heating bills by causing gaps in doors and windows that allow cold air inside. Dry sinuses can leave you susceptible to colds and flu. Allergy and asthma triggers may increase. Humidifiers help you control the moisture levels in your home so that you and your family feel better while also protecting your home.

Dehumidifiers

Like air that is too dry, air that's too moist can also be detrimental. Too much moisture can increase incidents of mold, mildew and bacteria, also increasing allergy and asthma triggers. High humidity attracts pests drawn to moisture. Whether you live in a humid climate or it's simply that time of year, a dehumidifier reduces excess moisture for greater comfort and healthier indoor air quality.

UV Air Purifiers

Air filtration is no longer the only tool for cleaning indoor air. UV Air Purifiers have become an effective method of killing germs, bacteria, flu and viruses inside the home. Do you get sick often? Are you scheduled for surgery? Do more to remove the harmful elements that can increase your risk of infection with a UV Air Purifier.

Energy and Heat Recovery Ventilators (ERV and HRV)

All homes need ventilation. Ventilation systems bring fresh air into your home while also exhausting stale air year around, even when windows and doors are closed. Most people don't keep windows and doors open all the time due to noise, weather, and safety concerns. In addition, today's homes are built tighter for energy efficiency. The exchange of fresh air offered by an ERV or HRV provides air that keeps occupants healthy, removes odors, reduces moisture, removes indoor pollutants and lowers the relative indoor humidity.