

**INSTALLER:** PLEASE FAMILIARIZE YOURSELF WITH THIS MANUAL BEFORE PROCEEDING WITH THE INSTALLATION. LEAVE THIS MANUAL WITH THE APPLIANCE FOR FUTURE REFERENCE.  
**CONSUMER:** RETAIN THIS MANUAL FOR FUTURE REFERENCE.



## INSTALLATION AND OPERATING INSTRUCTIONS

# THRU-THE-WALL PACKAGED UNIT

**HIGH EFFICIENCY GAS HEAT & ELECTRIC COOLING**

CONFORMS TO ANSI/UL STD. 1995, ANSI STD. Z21.47  
 CERTIFIED TO CAN/CSA STD. C22.2 NO. 236,  
 CAN/CSA STD. 2.3 AND CAN/CGA STD. 2.17

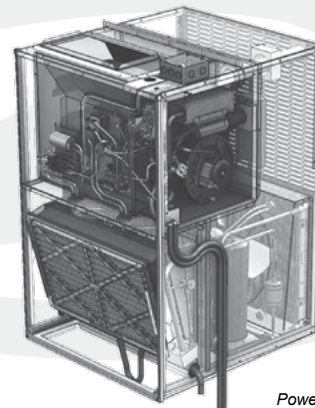

Powered By:

**Copeland**  
brand products



THE HIGHEST EFFICIENCY THRU-THE-WALL  
 SELF CONTAINED HEATING & COOLING UNIT

### ⚠ WARNING ⚠

#### ELECTRICAL SHOCK, FIRE OR EXPLOSION HAZARD

FAILURE TO FOLLOW SAFETY WARNINGS AND INSTRUCTIONS EXACTLY COULD RESULT IN SERIOUS INJURY, DEATH OR PROPERTY DAMAGE.

IMPROPER INSTALLATION, ADJUSTMENT, ALTERATION, SERVICE, OR MAINTENANCE CAN CAUSE INJURY OR PROPERTY DAMAGE. REFER TO THIS MANUAL. INSTALLATION AND SERVICE MUST BE PERFORMED BY A QUALIFIED INSTALLER, SERVICE AGENCY, OR THE GAS SUPPLIER.

UNIT CONTAINS R-410A REFRIGERANT AND POE COMPRESSOR OIL.

USE ONLY R-410A REFRIGERANT AND APPROVED POE COMPRESSOR OIL. PROPER SERVICE EQUIPMENT IS REQUIRED. USE ONLY R-410A APPROVED SERVICE EQUIPMENT.

FOR YOUR SAFETY, DO NOT STORE OR USE GASOLINE OR OTHER FLAMMABLE VAPORS AND LIQUIDS IN THE VICINITY OF THIS OR ANY OTHER APPLIANCE. SUCH ACTIONS COULD RESULT IN PROPERTY DAMAGE, PERSONAL INJURY, OR DEATH.

### ⚠ CAUTION ⚠

INSTALLATION SHALL BE MADE IN ACCORDANCE WITH THE REQUIREMENTS OF THE LOCAL AUTHORITIES HAVING JURISDICTION, AND WITH THE NATIONAL FUEL GAS CODE, ANSI Z223.1 (LATEST EDITION) AND THE NATIONAL ELECTRICAL CODE IN THE UNITED STATES OR CAN/CGA-B149.1 & .2 AND THE CANADIAN ELECTRICAL CODE CSA C22.1 PART 1 (LATEST EDITION) IN CANADA. ANY ALTERATION OF INTERNAL WIRING WILL VOID CERTIFICATION AND WARRANTIES.

### ⚠ IMPORTANT ⚠

- Installation and service must be performed by a qualified installer, service agency or the gas supplier.
- Before servicing, disconnect all electrical power to unit.
- When servicing controls, label all wires prior to disconnecting. Reconnect wires correctly.
- Verify proper operation after servicing.
- Do not store or use gasoline or other flammable vapors and liquids in the vicinity of this or any other appliance.
- After installing the unit, show user locations of main electrical Disconnect Switch to CondoPack and how the unit can be de-energized using switch.

#### **WHAT TO DO IF YOU SMELL GAS:**

- Do not try to light any appliance.
- Do not touch any electrical switch; do not use any phone in your building.
- Leave the building immediately.
- Immediately call your gas supplier from a neighbor's phone. Follow the gas supplier's instructions.
- If you cannot reach your gas supplier, call the fire department.

MANUFACTURER RESERVES THE RIGHT TO DISCONTINUE, OR CHANGE AT ANY TIME, SPECIFICATIONS OR DESIGNS WITHOUT NOTICE AND WITHOUT INCURRING OBLIGATIONS.

Wolf Steel Ltd., 24 Napoleon Rd., Barrie, ON, L4M 0G8 Canada /  
 103 Miller Drive, Crittenden, Kentucky, USA, 41030  
 Phone (866) 820-8686 • Fax (705) 725-1150 • www.napoleonheatingandcooling.com  
 • hvac@napoleonproducts.com

## TABLE OF CONTENTS

<b>1. MODEL NOMENCLATURE .....</b>	<b>3</b>
<b>2. OVERVIEW .....</b>	<b>3</b>
<b>3. SAFETY .....</b>	<b>4</b>
3.1 SAFETY SYMBOLS AND WARNINGS .....	4
3.2 SAFETY RULES .....	7
3.3 CODES .....	8
<b>4. INSTALLATION .....</b>	<b>9</b>
4.1 UNIT DIMENSIONS .....	10
4.2 UNIT LOCATION AND CLEARANCES .....	11
4.3 PACKAGED UNIT PREPARATION .....	16
4.4 WALL SLEEVE ASSEMBLY .....	17
4.5 UNIT SUPPORT .....	23
4.6 PACKAGED UNIT INSTALLATION .....	24
4.7 DUCTWORK .....	25
4.8 CONDENSATE DRAIN CONNECTION .....	27
4.9 VENTING AND COMBUSTION PIPING .....	28
4.10 GAS SUPPLY AND PIPING .....	28
4.11 GAS CONNECTIONS .....	28
4.12 GAS INLET PRESSURE .....	29
4.13 LEAK TESTING .....	30
4.14 PURGING GAS LINES .....	30
4.15 CONVERSIONS .....	30
4.16 ELECTRICAL .....	33
<b>5. STARTUP AND SHUTDOWN .....</b>	<b>41</b>
5.1 FURNACE STARTUP .....	41
5.2 FURNACE SHUTDOWN .....	42
5.3 AIR CONDITIONING STARTUP .....	42
5.4 AIR FLOW .....	43
<b>6. MAINTENANCE .....</b>	<b>45</b>
6.1 GENERAL SAFETY RULES .....	45
6.2 COOLING CHASSIS .....	46
6.3 AIR FILTER .....	46
6.4 LUBRICATION .....	46
6.5 GAS METER .....	47
6.6 ROUTINE MAINTENANCE .....	47
<b>7. TROUBLESHOOTING .....</b>	<b>48</b>
7.1 FURNACE TROUBLESHOOTING CHART .....	48
7.2 AIR CONDITIONING TROUBLESHOOTING .....	49
7.3 ADJUSTING SYSTEM CHARGE .....	50
7.4 DIAGNOSTIC CODES FOR STATUS LED .....	51
7.5 FAULT CODE HISTORY .....	51
<b>8. OWNER'S SERVICE INFORMATION .....</b>	<b>52</b>
<b>9. WARRANTY .....</b>	<b>53</b>

# 1. MODEL NOMENCLATURE

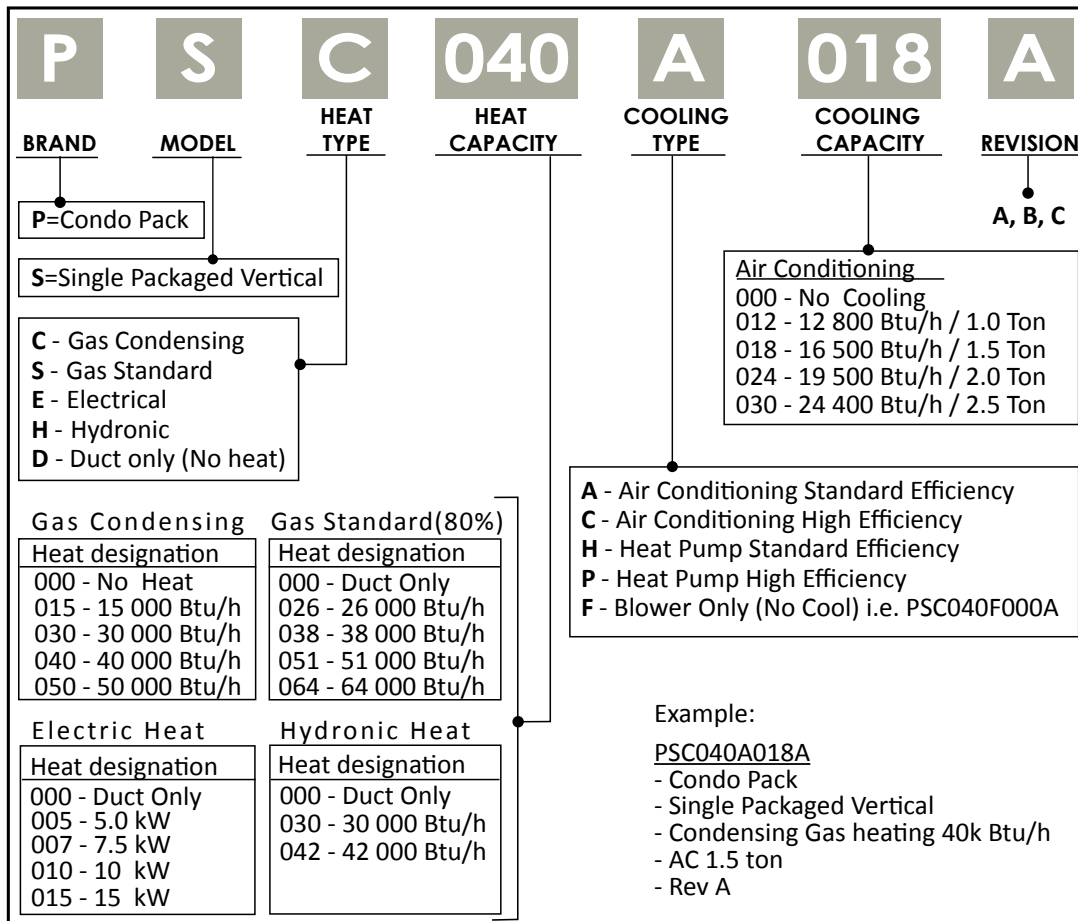

## 2. OVERVIEW

These instructions cover the installation of the Condo Pack, which consists of four separate sections: the wall sleeve, the cabinet, the air conditioning (AC) and the furnace modules. Instead of replacing the complete system, the AC and furnace modules can be partially or fully removed for servicing. All control harnesses are separated with modular quick disconnects, so module replacements do not require rewiring. Both modules have been factory run-tested and ready for easy installation as a complete package. This unit, equipped with a high efficiency furnace module, is certified as a Category IV direct vent central forced air furnace.

These instructions are intended as an aid to the licensed service technician. Improper installation may damage equipment, void the warranty, and can create a hazard, resulting in injury or death. Our HVAC systems and components are designed to be installed by qualified HVAC technicians ONLY. The installation of HVAC systems includes electrical, gas, and refrigerant connections and is regulated by a multiple set of laws, codes and guidelines, at the federal, state and local levels. It is the installer's responsibility to install the product in accordance with all applicable codes and regulations. It is the home owner's responsibility to properly maintain the equipment. NO WARRANTY is offered for the products that were installed by unlicensed/unauthorized persons. Failure to comply with this policy could lead to violations of applicable laws that are punishable. Documentation and specifications are continuously updated and subject to change. Please download the latest version of specifications and manuals at <http://www.napoleonheatingandcooling.com>.

## 3. SAFETY

Only trained service technicians familiar with standard service instructions and training materials should attempt installation, service, and repair of these units. Improper installation, adjustment, alteration, service, maintenance, or use can cause explosion, fire, electrical shock, or other conditions which may cause death, personal injury, or property damage. For information and assistance, consult a qualified installer, service agency, your distributor or branch.

Follow all safety codes. Wear safety glasses, protective clothing, and work gloves. Have fire extinguisher available. Read instructions thoroughly and follow all warnings or cautions included in literature and attached to the unit. Consult federal, provincial, state, and local codes for special requirements.

### 3.1 SAFETY SYMBOLS AND WARNINGS

Understand and pay particular attention to the words DANGER, WARNING, and CAUTION and the following defined symbols are used throughout this manual to notify the reader of potential hazards of varying risk levels.

#### **DANGER**

**INDICATES AN IMMEDIATELY HAZARDOUS SITUATION WHICH, IF NOT AVOIDED, WILL RESULT IN DEATH OR SERIOUS INJURY.**

#### **WARNING**

**INDICATES A POTENTIALLY HAZARDOUS SITUATION WHICH, IF NOT AVOIDED, COULD RESULT IN DEATH OR SERIOUS INJURY.**

#### **CAUTION**

**INDICATES A POTENTIAL HAZARDOUS SITUATION WHICH, IF NOT AVOIDED, MAY RESULT IN MINOR OR MODERATE INJURY. IT MAY ALSO BE USED TO ALERT AGAINST UNSAFE PRACTICES.**

#### **IMPORTANT**

**SUGGESTS IMPORTANT PROCEDURE STEPS TO INSURE PROPER INSTALLATION, RELIABILITY, OR OPERATION.**

#### **NOTE**

**HIGHLIGHTS SUGGESTIONS WHICH WILL RESULT IN ENHANCED INSTALLATION, RELIABILITY, OR OPERATION.**

**⚠ WARNING ⚠**

IF THE INFORMATION IN THESE INSTRUCTIONS IS NOT FOLLOWED EXACTLY, A FIRE OR EXPLOSION MAY RESULT, CAUSING PROPERTY DAMAGE, PERSONAL INJURY OR DEATH.

**FOR YOUR SAFETY**

DO NOT STORE OR USE GASOLINE OR OTHER FLAMMABLE VAPORS AND LIQUIDS, OR OTHER COMBUSTIBLE MATERIALS IN THE VICINITY OF THIS OR ANY OTHER APPLIANCE.

**WHAT TO DO IF YOU SMELL GAS**

- DO NOT TRY TO LIGHT ANY APPLIANCE.
- DO NOT TOUCH ANY ELECTRICAL SWITCH; DO NOT USE ANY PHONE IN YOUR BUILDING.
- IMMEDIATELY CALL YOUR GAS SUPPLIER FROM A NEIGHBOR'S PHONE, OR A CELLULAR PHONE FROM A LOCATION WELL AWAY FROM THE BUILDING. FOLLOW THE GAS SUPPLIER'S INSTRUCTIONS.
- IF YOU CANNOT REACH YOUR GAS SUPPLIER, CALL THE FIRE DEPARTMENT.
- DO NOT RE-ENTER THE BUILDING UNTIL AUTHORIZED TO DO SO BY THE GAS SUPPLIER OR THE FIRE DEPARTMENT.

IMPROPER INSTALLATION, ADJUSTMENT, ALTERATION, SERVICE OR MAINTENANCE CAN CAUSE INJURY, PROPERTY DAMAGE OR LOSS OF LIFE. REFER TO THIS MANUAL.

INSTALLATION AND SERVICE MUST BE PERFORMED BY A QUALIFIED INSTALLER, SERVICE AGENCY OR THE GAS SUPPLIER.

H3.3.3. GS\_CP

**⚠ WARNING ⚠**

FOR PROPER AND SAFE OPERATION THE FURNACE NEEDS AIR FOR COMBUSTION AND VENTILATION. DO NOT BLOCK OR OBSTRUCT AIR OPENINGS ON THE FURNACE, AIR OPENINGS TO THE AREA IN WHICH THE FURNACE IS INSTALLED, AND THE SPACINGS AROUND THE FURNACE.

**⚠ WARNING ⚠**

SHOULD THE GAS SUPPLY FAIL TO SHUT OFF OR IF OVERHEATING OCCURS, SHUT OFF THE GAS VALVE TO THE FURNACE BEFORE SHUTTING OFF THE ELECTRICAL SUPPLY.

**⚠ WARNING ⚠**

DO NOT USE THIS FURNACE IF ANY PART HAS BEEN UNDER WATER. A FLOOD DAMAGED FURNACE IS EXTREMELY DANGEROUS. ATTEMPTS TO USE THE FURNACE CAN RESULT IN FIRE OR EXPLOSION. A QUALIFIED SERVICE AGENCY SHOULD BE CONTACTED TO INSPECT THE FURNACE AND TO REPLACE ALL GAS CONTROLS, CONTROL SYSTEM PARTS, ELECTRICAL PARTS THAT HAVE BEEN WET OR THE FURNACE IF DEEMED NECESSARY.

**⚠ WARNING ⚠**

**THIS INFORMATION IS INTENDED FOR USE BY QUALIFIED HVAC TECHNICIANS. ANY ATTEMPT TO REPAIR A CENTRAL AIR CONDITIONING PRODUCT MAY RESULT IN PERSONAL INJURY AND/OR PROPERTY DAMAGE. THE MANUFACTURER OR SELLER CANNOT BE RESPONSIBLE FOR THE INTERPRETATION OF THIS INFORMATION, NOR CAN IT ASSUME ANY LIABILITY IN CONNECTION WITH ITS USE.**

**⚠ CAUTION ⚠**

UNIT CONTAINS R-410A REFRIGERANT AND POE COMPRESSOR OIL. USE ONLY R-410A REFRIGERANT AND APPROVED POE COMPRESSOR OIL. REFRIGERANT LINES MUST BE BRAZED AND RATED FOR R410 PRESSURES! PROPER SERVICE EQUIPMENT IS REQUIRED. USE ONLY R-410A APPROVED SERVICE EQUIPMENT. FAILURE TO USE PROPER SERVICE TOOLS MAY RESULT IN EQUIPMENT DAMAGE OR PERSONAL INJURY.

ALL R-410A SYSTEMS USE POE OIL. POE OIL EASILY ABSORBS MOISTURE FROM THE AIR. A SYSTEM WHICH HAS BEEN EXPOSED TO THE ATMOSPHERE FOR MORE THAN 4 HOURS REQUIRES THAT THE COMPRESSOR OIL BE REPLACED. NEVER BREAK A VACUUM WITH AIR AND ALWAYS CHANGE THE FILTER DRIER WHEN OPENING THE SYSTEM FOR COMPONENT REPLACEMENT.

**⚠ WARNING ⚠**

**HOT SURFACE! DO NOT TOUCH TOP OF COMPRESSOR. COMPRESSOR AND DISCHARGE PIPES MAY BE EXTREMELY HOT. THIS MAY CAUSE MINOR TO SEVERE BURNS.**

**⚠ CAUTION ⚠**

DURING THE INSTALLATION, TESTING, SERVICING, AND TROUBLESHOOTING OF THIS PRODUCT, IT MAY BE NECESSARY TO WORK WITH ELECTRICAL COMPONENTS. THERE IS A RISK OF ELECTRIC SHOCK WHICH CAN CAUSE INJURY OR DEATH: DISCONNECT ALL REMOTE ELECTRIC POWER SUPPLIES BEFORE SERVICING!

H3.3\_AC

**⚠ WARNING ⚠**

**THESE INSTRUCTIONS ARE INTENDED AS AN AID TO QUALIFIED SERVICE PERSONNEL FOR PROPER INSTALLATION, ADJUSTMENT AND OPERATION OF THIS UNIT. READ THESE INSTRUCTIONS THOROUGHLY BEFORE ATTEMPTING INSTALLATION OR OPERATION. FAILURE TO FOLLOW THESE INSTRUCTIONS MAY RESULT IN IMPROPER INSTALLATION, ADJUSTMENT, SERVICE OR MAINTENANCE, POSSIBLY RESULTING IN FIRE, ELECTRICAL SHOCK, CARBON MONOXIDE POISONING, EXPLOSION, PROPERTY DAMAGE, PERSONAL INJURY OR DEATH.**

H3.4.2\_CP

### 3.2 SAFETY RULES

1. Use this unit only with type of gas approved for the furnace module. Refer to the unit rating plate.
2. Store this unit only in dry indoor locations (protected from weather).
3. DO NOT install this unit outdoors or in a mobile home, trailer or recreational vehicle. This appliance is not designed/certified for these installations.
4. DO NOT install unit in a corrosive or contaminated atmosphere.
5. For lighting and shutting down the furnace refer to *Furnace Start Up and Furnace Shut Down*, section 5 of this manual.
6. Install this unit only in dry indoor locations (protected from weather).
7. Provide adequate combustion and ventilation air to the unit space as specified in section 4.9 "Venting and Combustion Piping".
8. Combustion products must be discharged outdoors using factory installed vent system only, as specified in section 4.9 "Venting and Combustion Piping".
9. Never test for gas leaks with an open flame. Use a commercially available soap solution made specifically for the detection of leaks to check all connections as specified in "Gas Supply and Piping" section of this manual.
10. Both Supply and Return Air must be ducted to the appliance from rooms separate to the enclosure housing the appliance. Be sure that duct system has external static pressure within allowable operating range (as listed on unit's Rating Plate). Completely seal supply and return air ducts to unit casing. See Section 4.7 "Ductwork" for more detail.
11. Always install unit to operate within the temperature-rise range and an external static pressure range (ducting), as listed on the unit rating plate.
12. A gas-fired unit for installation in a storage garage must be installed so that the ignition sources, including blowers and contactors (See page 15, "IMPORTANT", 1a.), are no less than 18" (457 mm) above the floor. The unit must be located, or protected to avoid physical damage by vehicles. See safety warnings.
13. Return air temperature range that must be maintained is:
  - between 55°F (13°C) and 80°F (27°C) for gas heat and
  - between 65°F (18°C) and 90°F (32°C) for air conditioning.
14. The furnace must be kept free and clear of insulating material. Carefully examine the furnace area when the furnace is installed or/when insulation is added. Insulating material may be combustible.
15. **DO NOT USE FOR HEATING AND COOLING BUILDINGS OR STRUCTURES UNDER CONSTRUCTION!** Units that are damaged or entrained with construction debris will not be covered under warranty.
16. Before installing unit, make sure you know all applicable codes. National, state and local codes may take precedence over any instructions in this manual. Be sure to consult:
  - Authorities having jurisdiction over HVAC system installations;
  - Local code authorities for information on electrical wiring.

## ⚠ WARNING ⚠

**WHEN THIS UNIT IS INSTALLED IN A STORAGE GARAGE, IT MUST BE INSTALLED SO THE BURNERS AND IGNITION SOURCE ARE LOCATED NO LESS THAN 18" (457 mm) ABOVE THE FLOOR TO PREVENT THE RISK OF IGNITING FLAMMABLE VAPORS WHICH MAY BE PRESENT IN THE GARAGE.**

**THE FURNACE MUST BE LOCATED OR PROTECTED TO AVOID PHYSICAL DAMAGE BY VEHICLES.**

**FAILURE TO HEED THESE WARNINGS CAN CAUSE A FIRE OR EXPLOSION, RESULTING IN PROPERTY DAMAGE, PERSONAL INJURY OR LOSS OF LIFE.**



### 3.3 CODES

#### 1. This unit must be installed:

- In accordance with all local codes, by-laws and regulations by those authorities having jurisdiction.
- In Canada, this furnace must be installed in accordance with the current CAN/CGA-B149.1 and B149.2 Natural Gas and Propane Code.
- In the United States, this furnace must be installed in accordance with the current ANSI Z223.1 (NFPA 54) National Fuel Gas Code.

#### 2. Electrical connections must be made in accordance with:

- Any applicable local codes, by-laws and regulations.
- Canada: current edition of CAN/CSA C22.1 and C22.2, Canadian Electrical Code (Part 1 and 2).
- United States: current edition of ANSI/NFPA 70, National Electrical Code.

#### 3. Codes and additional information may be obtained from:

Canadian Standards Association  
5060 Spectrum Way  
Mississauga, Ontario, L4W 5N6  
Phone: (416) 747-4000  
website: [www.csa.ca](http://www.csa.ca)

National Fire Protection Association  
1 Batterymarch Park  
Quincy, MA, 02169-7471  
Phone: (617) 770-3000  
website: [www.nfpa.org](http://www.nfpa.org)

American Gas Association  
400 North Capitol Street, NW,  
Suite 450  
Washington DC, 20001  
Phone: (202) 824-7000  
website: [www.aga.org](http://www.aga.org)

## ⚠ WARNING ⚠

**DO NOT INSTALL THIS UNIT IN A MOBILE HOME! THIS UNIT IS NOT APPROVED FOR INSTALLATION IN A MOBILE HOME. DOING SO COULD CAUSE FIRE, PROPERTY DAMAGE, PERSONAL INJURY OR LOSS OF LIFE.**

**THE FURNACE CONTAINS FOIL COVERED FIBERGLASS INSULATION. INHALATION OF FIBERGLASS PARTICLES IS ASSOCIATED WITH RESPIRATORY DISEASE INCLUDING CANCER.**

**NATURAL GAS AND PROPANE ARE NORMALLY ODORIZED BY THE FUEL SUPPLIER. IN SOME CASES, THE ODORANT MAY NOT BE PERCEIVABLE. INSTALLATION OF UL AND ULC RECOGNIZED FUEL GAS DETECTORS INSTALLED IN ACCORDANCE WITH THEIR MANUFACTURER'S INSTRUCTIONS ARE RECOMMENDED AS AN ADDITIONAL MARGIN OF SAFETY.**

**THE EXHAUST GASES FROM THIS FURNACE CONTAIN CHEMICALS WHICH ON SOME OCCASIONS MAY INCLUDE CARBON MONOXIDE. CARBON MONOXIDE IS AN ODORLESS, TASTELESS, CLEAR COLORLESS GAS WHICH IS HIGHLY TOXIC. EVEN LOW CONCENTRATIONS ARE SUSPECTED OF CAUSING BIRTH DEFECTS AND OTHER REPRODUCTIVE HARM.**

**UL AND ULC RECOGNIZED CO DETECTORS ARE REQUIRED FOR ALL BUILDINGS EQUIPPED WITH FOSSIL FUEL BURNING APPLIANCES. ALL CO DETECTORS SHOULD BE INSTALLED IN ACCORDANCE WITH THEIR MANUFACTURER'S INSTRUCTIONS AND APPLICABLE LOCAL BUILDING CODES.**

**FIRE, EXPLOSION OR CARBON MONOXIDE POISONING HAZARD!  
FAILURE TO REPLACE WITH PROPER CONTROL COULD RESULT IN FIRE, EXPLOSION OR CARBON MONOXIDE POISONING.  
REPLACE GAS VALVE ONLY WITH THE SAME MODEL NUMBER OR AS SPECIFIED BY THE MANUFACTURER.**



## 4. INSTALLATION

The unit is shipped in one package, completely assembled and wired. The air conditioning and furnace condensate drains are shipped separately with the unit for field install.

If any damage is found, proper notation should be made on the carrier's freight bill. Damage claims should be filed with the carrier as quickly as possible.

Check the rating plate (at the front of the access panel) to confirm heating and cooling capacities. The unit should be operated only with the type of gas and electrical supply noted on the rating plate.

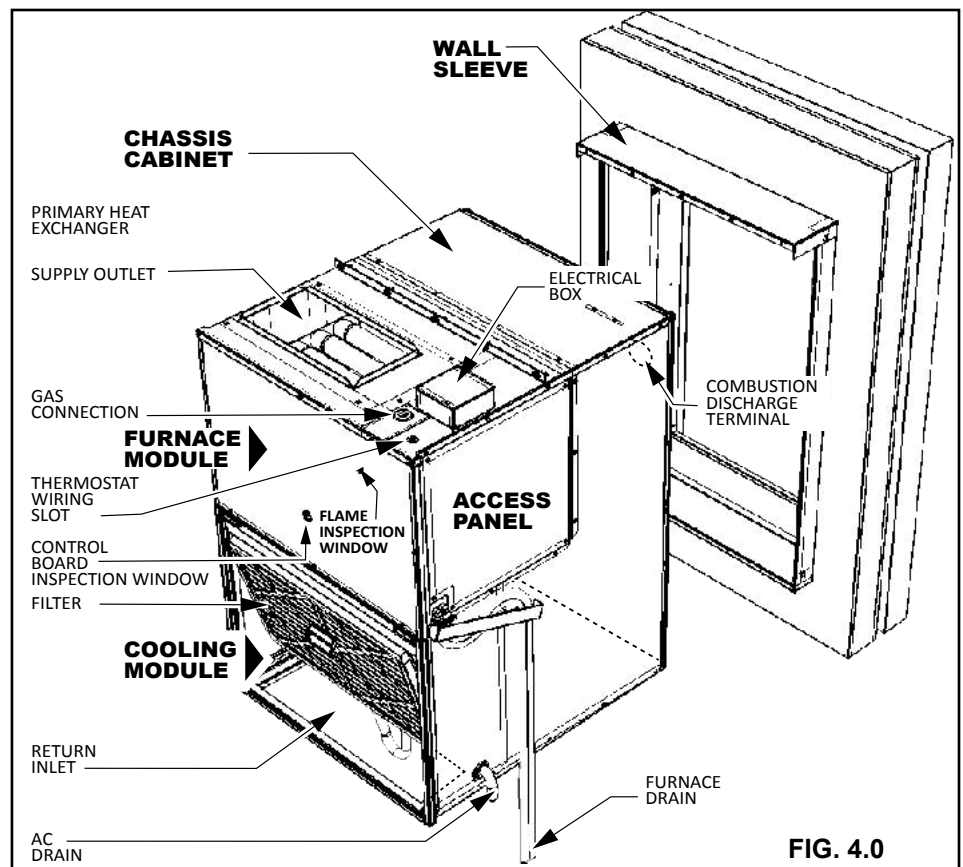

FIG. 4.0

### ⚠ IMPORTANT ⚠

**BEFORE INSTALLATION, REMOVE THE CHASSIS SHIPPING BRACKETS AND REPLACE THE SCREWS BACK TO THE UNIT.**

1. The furnace must not be located in an area where the combustion air is laden with chemical compounds such as bromine, chlorine or fluorine, as may be found in swimming pool chemicals, laundry detergents, etc. These compounds when exposed to flame, form acids which attack the heat exchanger and other components.

Exposure to the following substances in the combustion air supply (but not limited to the following) are not allowed, and will affect warranty claims:

- Aerosols, particularly CFC based or propelled aerosols
  - Air fresheners
  - "Airplane Glue" and similar adhesives and cements
  - Ammonia, as commonly found in permanent wave solutions used in hair dressing salons
  - Anti-static fabric softeners used in clothes dryers
  - Carbon tetrachloride
  - Chlorinated cleaners and waxes
  - Chlorine and bromine based swimming pool chemicals
  - De-icing salts or chemicals (rock salt, etc.)
  - Dry cleaning fluids such as perchloroethylene
  - Fumes from curing polyurethane and similar substances
  - Halogen based refrigerants including R-12 and R-22
  - Hydrochloric acid, muriatic acid and other acid based masonry washing and curing materials
  - Printer's inks, paint removers, varnishes, varsol, toluene, etc.
  - Water softener salt and chemicals
2. If the furnace is installed in an area where freezing may occur, a garage, an attic, a crawl space or any unconditioned space, steps must be taken to protect the condensate trap and drain line from freezing.

H8.2.1

4.1 UNIT DIMENSIONS

IOM

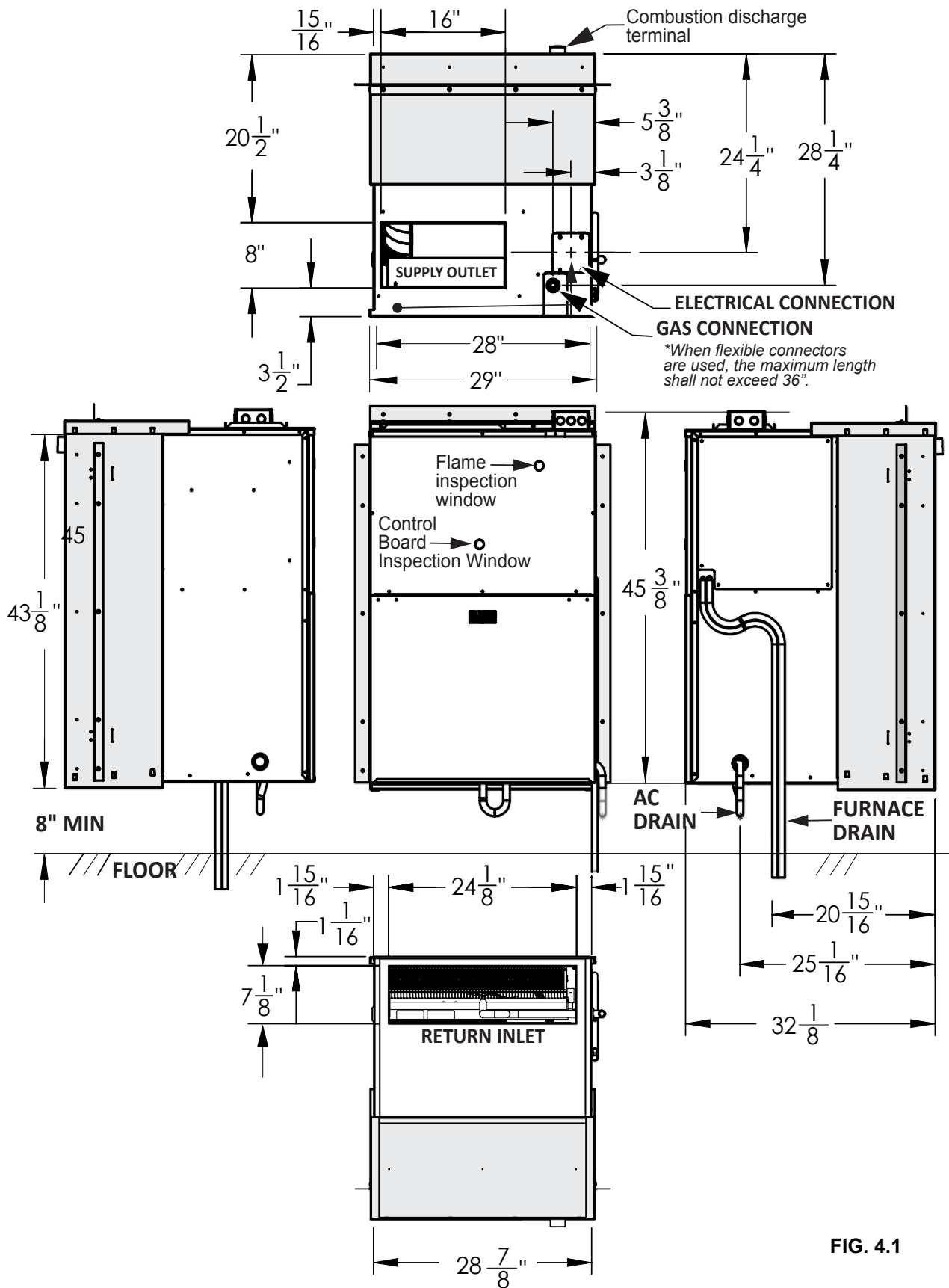
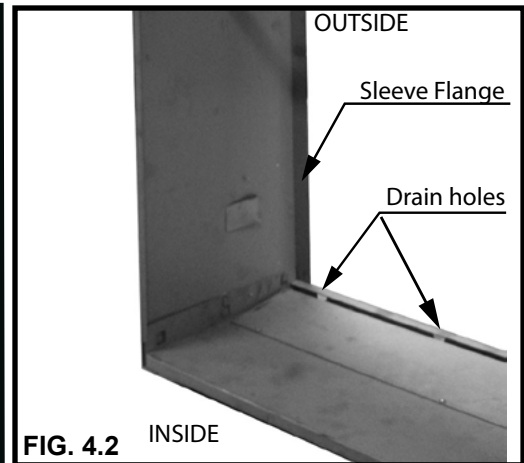

FIG. 4.1

## 4.2 UNIT LOCATION AND CLEARANCES

NOTE
ALTHOUGH IT IS NOT POSSIBLE TO DETAIL ALL OF CONSTRUCTION PARAMETERS THAT COULD BE ENCOUNTERED, THE FOLLOWING GUIDELINES AND PRECAUTIONS ARE RECOMMENDED:
<ul style="list-style-type: none"> <li>• <b>MASONRY WALLS MUST HAVE A LINTEL TO SUPPORT THE WALL.</b></li> <li>• <b>DURING THE WALL SLEEVE ASSEMBLY PAY ATTENTION THAT THE SIDE PANEL FLANGES AND THE BASE PANEL DRAIN HOLES ARE ON THE SAME SIDE OF WALL SLEEVE, SEE FIG 4.2.</b></li> </ul>



To minimize the effect of interaction between multiple units in a building there are some general location considerations that need to be taken into account.

The installer must verify that these conditions have been met before installing the unit. Installation of units in locations that do not follow these rules may lead to abnormal operation and premature failure. The use of these general rules may differ depending on each individual application. Please contact the manufacturer or your dealer for alternatives and application assistance.

### The general location considerations are:

- Each wall with Condo Pack unit installed should be at least 2ft away (for every floor) from the opposite building wall facing the unit. If facing wall also has a Condo Pack unit installed, those two walls should be at least 4ft apart. See “*Minimum Distance to the Opposite Wall*” Table 1 below.
- A six story building with six Condo Pack units installed in a vertical array, should be at least 12ft away from the opposite building wall and at least 24ft away if the opposite building wall also contains Condo Pack units.
- Buildings taller than six stories will have the same distance parameters as six-story buildings.
- If three or more adjacent walls form an air shaft with Condo Pack units facing each other in each wall, the distance between opposite walls should be increased by 20%.

**TABLE 1**

NUMBER OF FLOORS WITH THE UNITS	MINIMUM DISTANCE TO THE OPPOSITE BUILDING WALL	
	WITHOUT an unit installed in the opposite building wall	WITH an unit installed in the opposite building wall
1	2 feet	4 feet
2	4 feet	8 feet
3	6 feet	12 feet
4	8 feet	16 feet
5	10 feet	20 feet
6 or more	12 feet	24 feet

- At least 32” of unobstructed space should be provided in front of the indoor side, whether enclosed or not, in order to change filters, for unit inspection and to permit removal of the cooling module should repair be required.
- Do not install directly on carpeting, tile, or other combustible material other than wood flooring. The grille side of the unit should protrude minimum 1/2” but no more than 1” (maximum) from the face of the building and should not be obstructed by foreign objects. Refer to FIG. 4.2.2.
- If the unit is installed in an outside wall of a storage garage, it must be located or protected to avoid physical damage by vehicles. This unit must be installed so that no electrical components are exposed to water.

### 4.2.1 Venting Guidelines

This appliance should be installed in a location such that the vent outlet is located in the following manner:

#### In Canada:

In addition to the general guidelines, in Canada, the vent exhaust shall not terminate:

- Directly above a paved sidewalk or paved driveway which is located between two single-family dwellings and serves both dwellings;
- Less than 7 feet (2.1m) above a paved sidewalk or paved driveway located on public property;
- Within 6 feet (1.8m) of a mechanical air supply inlet to any building;
- Above a meter/regulator assembly within 3 feet (.91m) horizontally of the center line of the regulator;
- Within 3 feet (.91m) of any service regulator vent outlet;
- Less than 12" (305mm) above grade level or anticipated snow level;
- Within 12" (305mm) of any door, window that can be opened, or non-mechanical air supply inlet to any building;
- Within 12" (305mm) of the combustion air inlet of any other appliance;
- Recommended practice (where practicable) is to maintain the same vertical clearance between the vent and the overhang as the horizontally distance the overhang protrudes from the building.
- Unless governing bodies having local jurisdiction specify a minimum clearance larger, the minimum clearance between a vent terminal and a overhanging structure shall be 40 inches (1m).

#### In USA:

In addition to the general guidelines, in the United States, the vent exhaust shall be installed in accordance with the following:

- The clearance from the bottom of the terminal to grade shall be 12" (305mm).
- The vent shall not terminate over public walkways or over an area where condensate or vapor could create a nuisance or hazard.
- The vent terminal shall be installed 4 feet (1.2m) below, 4 feet (1.2m) horizontally from, or 1 foot (305mm) above any door, window, soffit, under eave vent or gravity air inlet to the building.
- The vent terminal shall have a minimum horizontal clearance of 4 feet (1.2m) from electric meters, gas meters, regulators and relief equipment.
- Locate the vent terminal 3 feet (0.91m) above any forced air inlet located within 10 feet (3m). Any fresh air or make-up air inlet, such as for a dryer or furnace area is considered a forced air inlet.

Avoid locating the terminals where the flue gas could become stagnant and allow recirculation into the combustion air intake.

Avoid locating the terminal in locations where dripping condensate may cause problems such as sidewalks, patios, above planters, near windows where exhaust gases may cause fogging, icing, etc.

Avoid locating the termination too close to shrubs and other vegetation. The condensate may stunt or kill them.

Caulk all cracks, seams or joints within a 6 foot (1.8m) radius of the termination.

Do not terminate under a deck unless there is adequate clearance to prevent damage from the flue gases. A termination may be located at the end of a patio deck. Piping running beneath the deck must be suitably insulated and suspended in a manner to prevent condensate from collecting and freezing.

When locating vent terminations, consideration must be given to prevailing winds, location, and other conditions which may cause recirculation of the combustion products of adjacent vents.

**Check local codes for distance between vent terminal and a inside corner formed by two exterior walls. If not specified by local code, minimum distance between vent terminal and an inside corner formed by two exterior walls is 6 inches (0.15m).**

## ▲ CAUTION ▲

IMPROPER LOCATION OR INSTALLATION CAN RESULT IN STRUCTURAL DAMAGE TO THE BUILDING, DAMAGE TO THE EXTERIOR FINISH OF THE BUILDING, OR MAY ALLOW RECIRCULATION OR FREEZING OF THE FLUE GASES ONTO OR INTO THE COMBUSTION AIR INTAKE. MOISTURE IN THE FLUE GASES CONDENSES AS IT LEAVES THE TERMINALS. THIS MOISTURE CAN FREEZE ON EXTERIOR WALLS, SOFFITS, AND OTHER NEARBY OBJECTS. SOME DISCOLORATION IS TO BE EXPECTED.

Recommended vertical clearance of a vent terminal and overhanging structure should be maximized to prevent condensate products from depositing and freezing on overhang. This practice helps prevent degradation of building materials.

Recommended practice (where practicable) is to maintain the same vertical clearance between the vent and the overhang as the horizontally distance the overhang protrudes from the building.

Unless governing bodies having local jurisdiction specify a minimum clearance larger, the minimum clearance between a vent terminal and a overhanging structure shall be 40 inches (1m).

Any adjacent painted surfaces should be in good condition; no cracks, peeling paint, etc. If wooden surfaces that may be periodically exposed to flue gases are present, consider treating with a sealer.

H15.5\_CP

<b>⚠ WARNING ⚠</b>
<b>THIS FURNACE IS CERTIFIED FOR INSTALLATION ON COMBUSTIBLE FLOORS. THIS SHALL BE INTERPRETED AS A WOOD FLOOR ONLY.</b>
<b>THE FURNACE MUST NOT BE INSTALLED DIRECTLY ON CARPETING, OR OTHER COMBUSTIBLE MATERIAL EXCEPT WOOD.</b>
<b>INSTALLATION ON COMBUSTIBLE MATERIAL OTHER THAN WOOD CAN RESULT IN FIRE, CAUSING PROPERTY DAMAGE, PERSONAL INJURY OR DEATH.</b>
<b>THE AREA AROUND THE FURNACE MUST BE KEPT CLEAR AND FREE OF ALL COMBUSTIBLE MATERIALS INCLUDING GASOLINE AND OTHER FLAMMABLE VAPORS AND LIQUIDS.</b>
<b>THE HOMEOWNER SHOULD BE CAUTIONED THAT THE FURNACE AREA MUST NOT BE USED AS A CLOSET OR FOR ANY OTHER STORAGE PURPOSE.</b>

H3.7. AC

This design is certified for thru-the-wall installation only. The interior portions of the unit may be surrounded by a closet with clearances to combustible material as listed on the nameplate. Adequate clearance must be provided to install the union and manual shut-off valve as well as accessibility to field wiring junction box.

**Minimum clearances to combustibles derived from factory testing are shown below and also on the nameplate of the unit:**

**TABLE 2**

**MINIMUM CLEARANCES TO COMBUSTIBLE MATERIALS.**

**DÉGAGEMENTS MINIMAUX PAR RAPPORT AUX MATÉRIAUX COMBUSTIBLES.**

<b>TOP / DESSUS</b>	<b>2 " (50.8 mm)</b>
<b>PLENUM / PLÉNUM</b>	<b>1 " (25 mm)</b>
<b>FRONT / AVANT</b>	<b>10" (254 mm)</b>
<b>BACK / ARRIÈRE</b>	<b>0</b>
<b>RIGHT SIDE / CÔTÉ DROIT</b>	<b>0*</b>
<b>LEFT SIDE / CÔTÉ GAUCHE</b>	<b>0</b>
<b>BOTTOM / FOND</b>	<b>0***</b>
<b>FLUE PIPE / TUYAU</b>	<b>0</b>

\* RECOMMENDED 2 " (50.8 mm) CLEARANCE FOR SERVICING

\*\*\* CERTIFIED FOR CLOSET INSTALATION ON COMBUSTIBLE FLOORING.

\*\*\* CERTIFIÉ POUR L'INSTALLATION DANS UN PLACARD SUR UN PLANCHER COMBUSTIBLE.

FIG. 4.2.1 - DIRECT VENT TERMINAL CLEARANCES

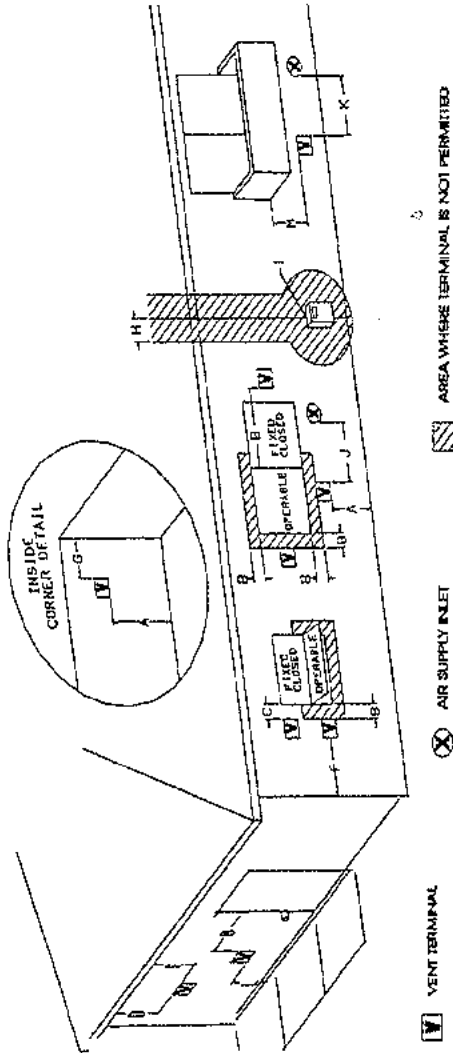

	Canadian Installations 1	US Installations 2
A=	Clearance above grade, veranda, porch, deck, or balcony 12 inches (30 cm)	US Installations 2 6 inches (15 cm) for appliances ≤ 10,000 Btu/h (3 kW), 12 inches (30 cm) for appliances > 10,000 Btu/h (3 kW) and ≤ 50,000 Btu/h (15 kW), 36 inches (91 cm) for appliances > 50,000 Btu/h (15 kW)
B=	Clearance to window or door that may be opened	6 inches (15 cm) for appliances ≤ 10,000 Btu/h (3 kW), 12 inches (30 cm) for appliances > 10,000 Btu/h (3 kW) and ≤ 50,000 Btu/h (15 kW), 36 inches (91 cm) for appliances > 50,000 Btu/h (15 kW)
C=	Clearance to permanently closed window	6 inches (15 cm) for appliances ≤ 10,000 Btu/h (3 kW), 9 inches (23 cm) for appliances > 10,000 Btu/h (3 kW) and ≤ 50,000 Btu/h (15 kW), 36 inches (91 cm) for appliances > 50,000 Btu/h (15 kW)
D=	Vertical clearance to ventilated soffit located above the terminal within a horizontal distance of 2 feet (61 cm) from the center line of the terminal	
E=	Clearance to unventilated soffit	
F=	Clearance to outside corner	
G=	Clearance to inside corner	
H=	Clearance to each side of center line extended above meter/regulator assembly	3 feet (91 cm) within a height 15 feet (4.5 m) above the meter/regulator assembly
I=	Clearance to service regulator vent inlet	3 feet (91 cm)
J=	Clearance to mechanical air supply inlet	6 feet (1.83 m)
K=	Clearance to non-mechanical air supply inlet to building or the combustion air inlet to any other appliance	6 inches (15 cm) for appliances ≤ 10,000 Btu/h (3 kW) and ≤ 100,000 Btu/h (30 kW), 12 inches (30 cm) for appliances > 100,000 Btu/h (30 kW)
L=	Clearance above paved sidewalk or paved driveway located on public property	7 feet (2.13 m) †
M=	Clearance under veranda, porch, deck, or balcony	12 inches (30 cm) ‡

1 In accordance with the current CSA B149.1, Natural Gas and Propane Installation Code  
 2 In accordance with the current ANSI Z223.1/NFPA 54, National Fuel Gas Code  
 † A vent shall not terminate directly above a sidewalk or paved driveway that is located between two single-family dwellings and serves both dwellings.  
 ‡ Permitted only if veranda, porch, deck, or balcony is fully open on a minimum of two sides beneath the roof.  
 \* Clearances not specified in ANSI Z223.1/NFPA 54 or CSA B149.1, the following statement shall be included:  
 "Clearance in accordance with local installation codes and the requirements of the gas supplier and the manufacturer's installation instructions."

The minimum clearances required for installation and accessibility are shown below. These clearances should be followed unless otherwise approved by the manufacturer.

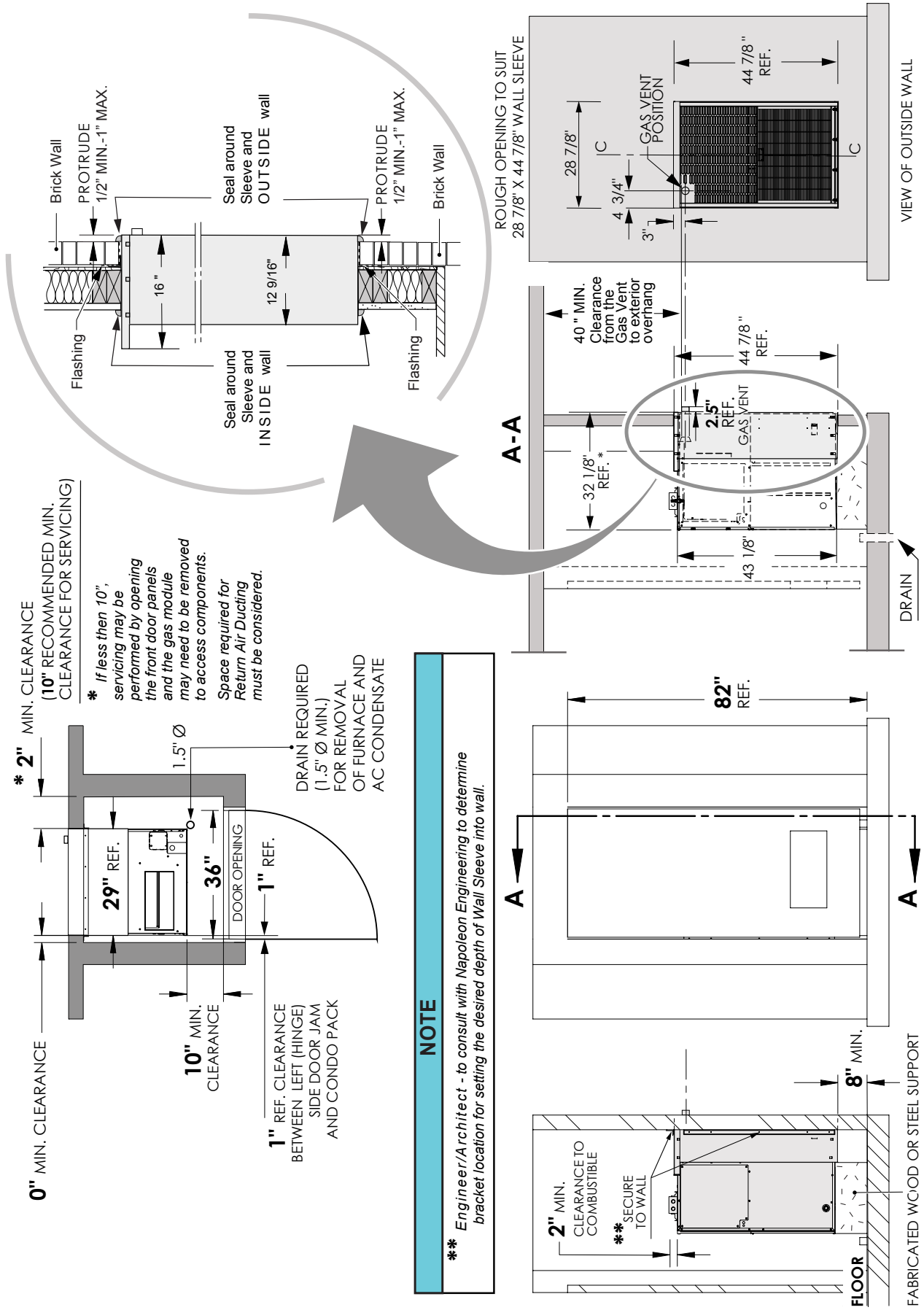

**NOTE**

**\*\* Engineer/Architect - to consult with Napoleon Engineering to determine bracket location for setting the desired depth of Wall Sleeve into wall.**

FIG. 4.2.2.



### 4.3 PACKAGED UNIT PREPARATION

IOM

#### NOTE

- THIS UNIT MUST BE INSTALLED IN ACCORDANCE WITH ALL APPLICABLE CODES.
- THIS UNIT IS APPROVED FOR THRU-THE-WALL INSTALLATION ONLY.
- THESE INSTALLATION AND MAINTENANCE INSTRUCTIONS SHOULD BE LEFT WITH THE UNIT FOR FUTURE REFERENCE.

#### Prior to installing the unit in the wall opening:

1. Remove the brackets connecting the unit to the skid.
2. Remove the cooling module.

#### ⚠ IMPORTANT ⚠

1. The unit must be installed a minimum of 8" above finished floor.
  - a. If unit is installed in a storage garage, all ignition sources (electric contactors and motors included) must be positioned at a minimum of 18" (457mm) above the floor, and it must be protected from physical damage by vehicles, consistent with CAN/CSA-B149.
2. The entire unit must not be installed outside. This unit is designed for indoor installation on to an exterior wall having an opening for condenser airflow.
3. The grille side of the unit should extend 1/2" Min. - 1" Max. beyond the exterior wall to allow moisture that may enter the outdoor section to drain.
4. DO NOT install this unit at an exterior wall location that will position the bottom of the wall grille below the exterior grade level. Below grade installation will allow the accumulation of rain or snow into the wall sleeve and unit base, and could result in water penetration into the building interior.
5. The grille side must be:
  - a. Kept free of any obstructions that could reduce or alter the air flow pattern. The unit must be installed at least 3' (0.92m) from electric meters, gas meters, regulators, and relief equipment in Canada, in accordance with CAN/CSA-B149 or 4' (1.22 m) in U.S. in accordance to NFPA 54, ANSI Z223 installation codes.
  - b. The vent of the unit is located at the outside grille. Distances from adjacent public walkways, adjacent buildings, windows, and building openings must be consistent with the National Fuel Gas Code ANSI Z223.1 and/or CAN/CSA-B149 installation codes, as well as local codes.
6. Masonry walls must have a lintel to support the wall, as per National and local building codes.
7. The interior of the unit may be installed with clearances noted on the nameplate to adjacent combustible surfaces.
8. The unit shall not be installed directly on carpeting, tile or other combustible material, except wood flooring.
9. In order to be able to remove the chassis, at least 32" of open area must be left unobstructed in front of the front doors. The drain pan and condensate trap line should be connected to the floor drain.
10. Caulk and seal all spaces around the top, sides and bottom of the exterior grille area, making sure that THE OPENINGS FOR DRAINAGE IN THE BOTTOM EDGE ARE NOT BLOCKED. Refer to "4.2 Unit Location and Clearances".

## 4.4 WALL SLEEVE ASSEMBLY

### ⚠ WARNING ⚠

THESE INSTRUCTIONS ARE INTENDED AS AN AID TO QUALIFIED SERVICE PERSONNEL FOR PROPER INSTALLATION, ADJUSTMENT AND OPERATION OF THE UNIT. READ THESE INSTRUCTIONS THOROUGHLY BEFORE ATTEMPTING INSTALLATION OR OPERATION. IMPROPER INSTALLATION, ADJUSTMENT, SERVICE, OR MAINTENANCE CAN CAUSE PROPERTY DAMAGE, PERSONAL INJURY, OR DEATH. CONSULT A QUALIFIED INSTALLER OR SERVICE AGENCY FOR INFORMATION AND ASSISTANCE.

INCLUDED IN THE CWSMUA KIT:

TABLE 3

ITEM	QTY	PART NAME	MANUFACTURING DESCRIPTION	PART NO
1	1	Top panel	PANEL, SLEEVE TOP POWDER	W475-0978-(color code)
2	1	Base panel	PANEL, SLEEVE BASE POWDER	W475-0975-(color code)
3	1	Right side panel	PANEL, SLEEVE RS POWDER	W475-0977-(color code)
4	1	Left side panel	PANEL, SLEEVE LS POWDER	W475-0976-(color code)
5	2	Side support bracket	BRACKET, SIDE SUPPORT	W080-1444
6	1	Top support bracket	BRACKET, TOP SUPPORT	W080-1445
7	25	Screw #8-32x.315 Steel Trilobular	SCREW, #8-32 x .315 QUAD HEX WASHER	W570-0162
10	2	Squaring brace	BRACE, SQUARING	W080-1433
11	1	Squaring brace middle	BRACE, SQUARING	W075-0019

SHOWN BUT NOT INCLUDED IN THE CWSMUA KIT:

ITEM	QTY	PART NAME	MANUFACTURING DESCRIPTION	PART NO
8	12.5F	Gasket D-Channel 28.9" long	GASKET, D-CHANNEL EPDM (included in W020-0835 CondoPack baggie)	W290-0256
9		Gasket D-Channel 44" long		

The wall sleeve is designed to be installed into the wall during the construction of the building, in order to provide an accurate opening and easier installation of thru-the-wall packaged unit later on, after building is completed.

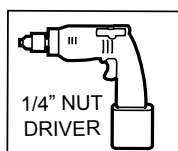

#### LEGEND

1. Top Panel
2. Base Panel
3. Right Side Panel
4. Left Side Panel
5. Side Support Bracket
6. Top Support Bracket
7. Screw #8-32x.315 Steel Trilobular
8. Gasket D-Channel 28.9" long
9. Gasket D-Channel 44" long
10. Squaring Brace
11. Squaring Brace Middle

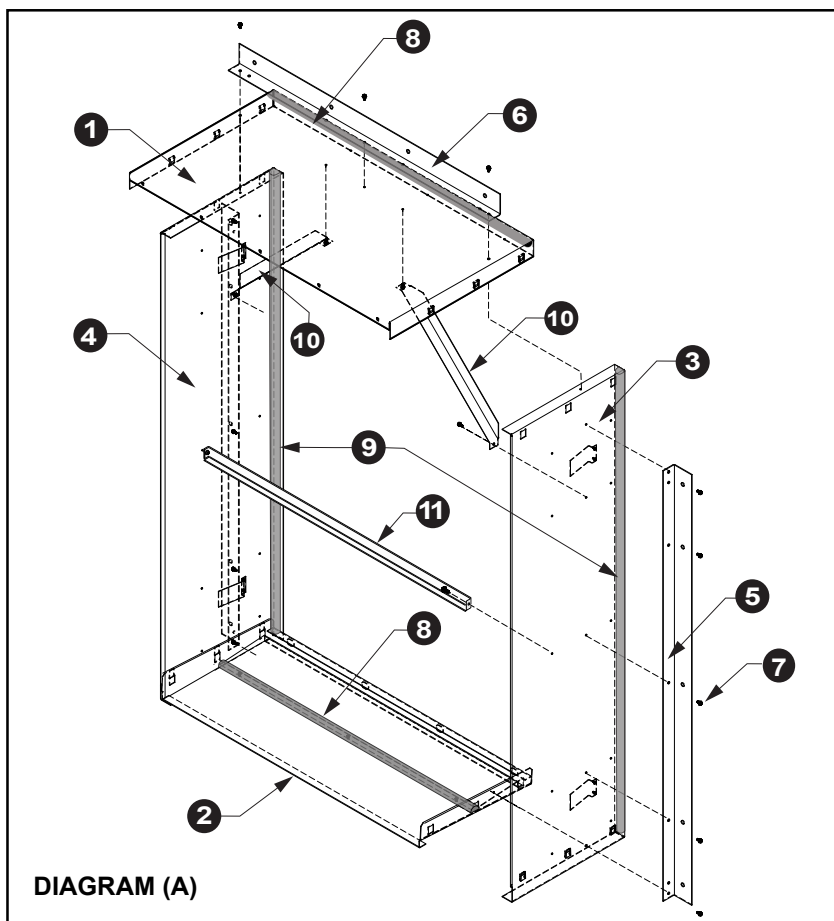

1. Place Base part (2) on the floor and attach Right Side Panel (3):
  - a. Position Base Panel (2) to seat behind flanges on the Side Panel (3).
  - b. Bring together panel clips and openings (FIG. 1).

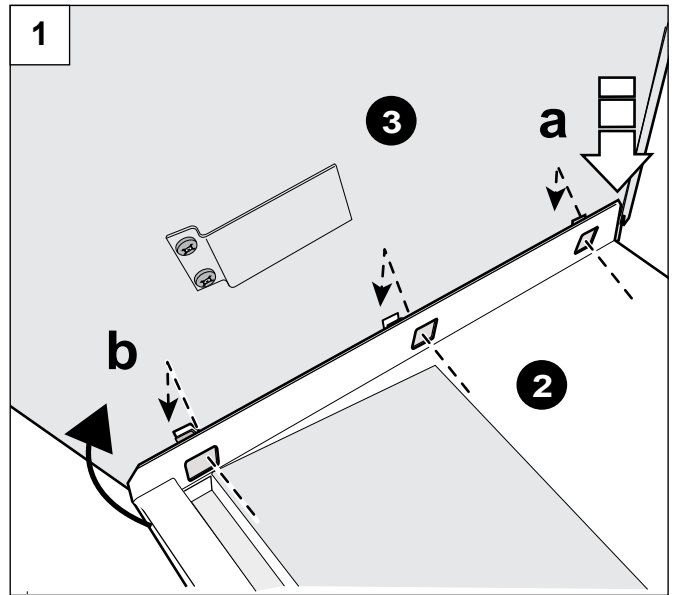

2. Press down firmly to lock base panel into place (FIG. 2).

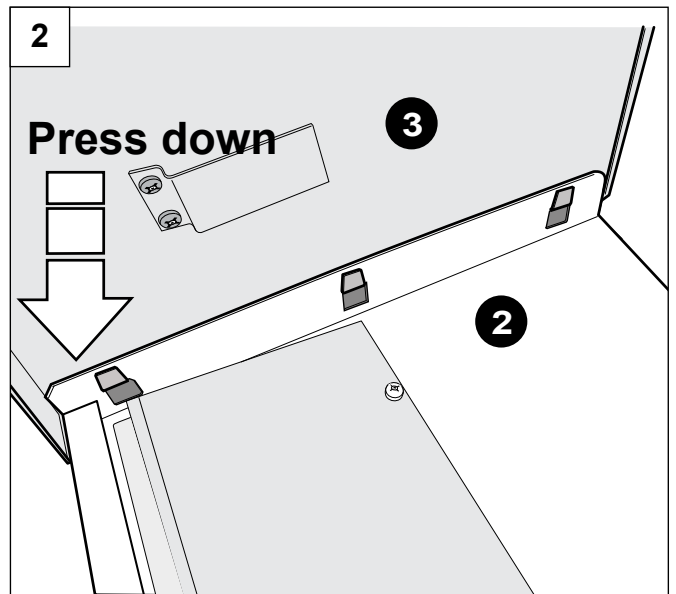

3. Attach Left Side Panel (4) to Base (2). Repeat procedure from step 2 (FIG. 2).

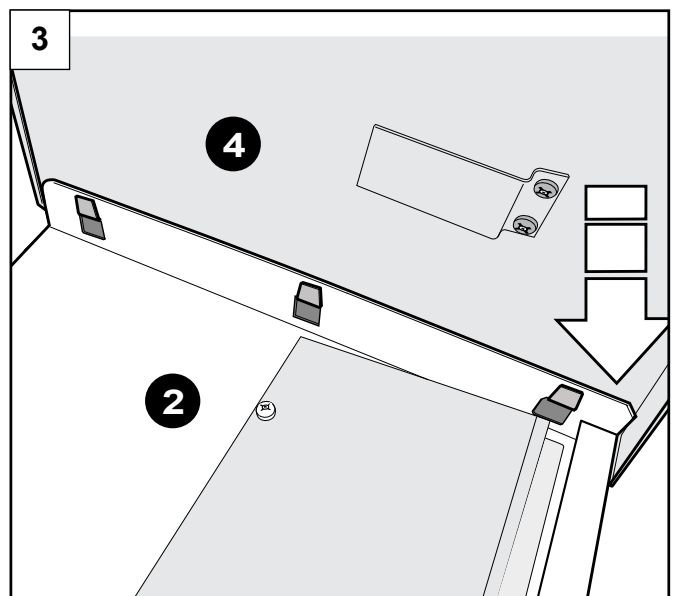

- 4.** Check for parallel position of Left and Right Side Panels (3) and (4). Secure connection with Base Panel (2), see (FIG. 4).

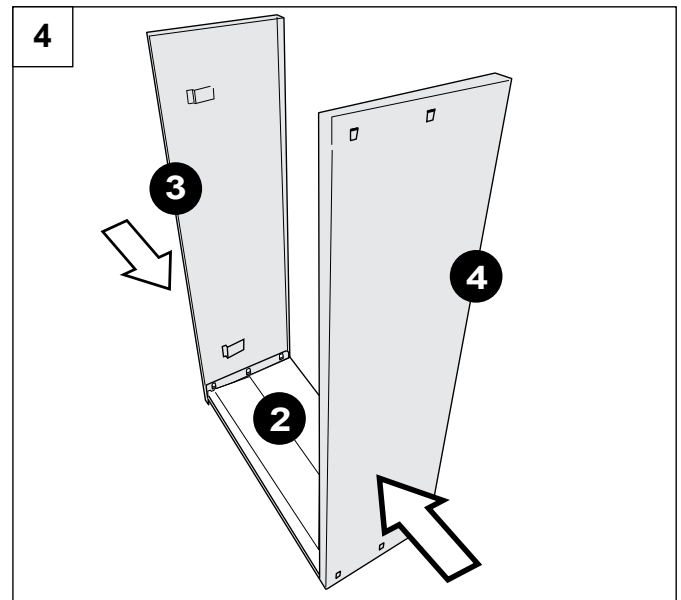

- 5.** Attach Top Panel (1) to Left and Right Side Panels (3) and (4). Align connection openings and secure the assembly by pushing the clips in place (FIG. 5).

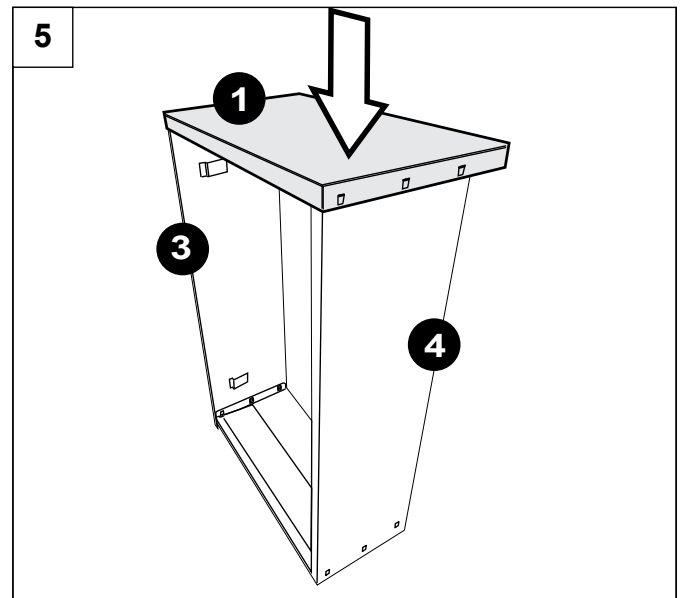

- 6.** Attach Squaring Braces (10) to the inner sides of both, Top Panel and the Side Panels, by inserting the screws from inside.

- 7.** To attach the Squaring Brace (10) to the Side Panels (3) and (4) use the 1/8" holes located 10" down from the top and 3.5" from the outside flange (FIG. 7).

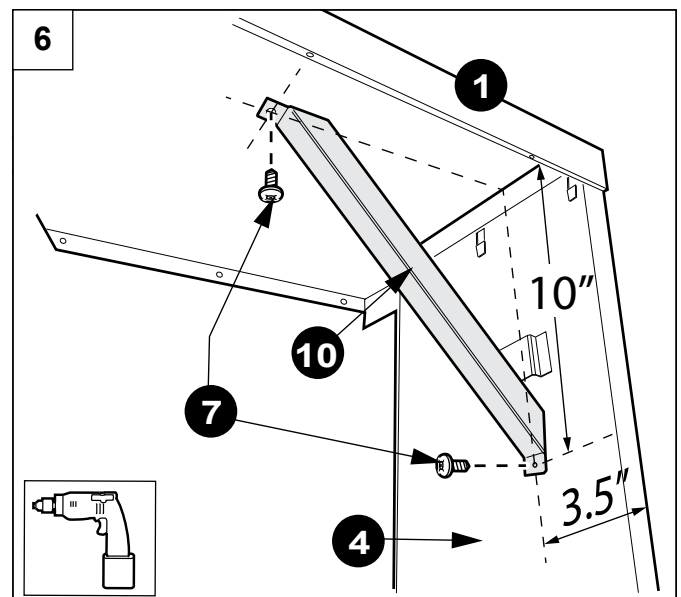

**NOTE:** The following support bracket locations are for installations where the wall sleeve is installed from the **OUTSIDE** of the building.

For installations where the wall sleeve is installed from the **INSIDE** of the building, the Side Support Brackets (5) need to be mounted on **INTERIOR** wall, so they will need to be relocated on the wall sleeve (new screw positions may need to be created).

8. Attach the Side Support Brackets (5) to the Side Panels (3) & (4) and to Base Panel with four screws through the shorter flange (FIG. 8).
9. Select the set of mounting holes based on type of construction wall face application (brick, stucco, siding, etc.):
  - a. For brick or stucco wall, use pre-drilled holes located 3.5" from outside edge (FIG. 9).
  - b. For siding type of wall, use holes located 1.5" from outside edge (FIG. 9).
  - c. Attach Top Support Bracket (6) to the Top Panel (1) using three screws provided (7), (FIG. 9).
  - d. Using two mounting screws (7), install Middle Squaring Brace (11) across the wall sleeve, as shown in the DIAGRAM (A) and FIG. 10.
  - e. Refer to "Wall Sleeve Installation", FIG 12 and FIG 13.
  - f. Do not remove Squaring Braces (10) and (11) from the wall sleeve if you do not plan to install the CondoPack unit immediately.
  - g. Fill the clearance space between the sleeve and a wall framing with low expanding insulation foam (this is for additional protection against air infiltration during the periods of very high winds).
10. **Prior to installing CondoPack into the wall sleeve:**
  - Remove squaring braces from wall sleeve.
  - Apply self-adhesive D-Channel Gasket strips (8) & (9) to inside surface of sleeve front flanges, as shown in FIG. 10.

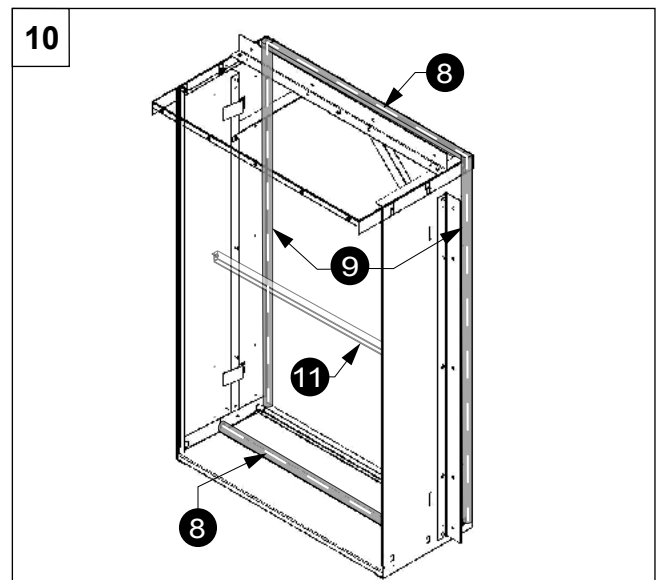
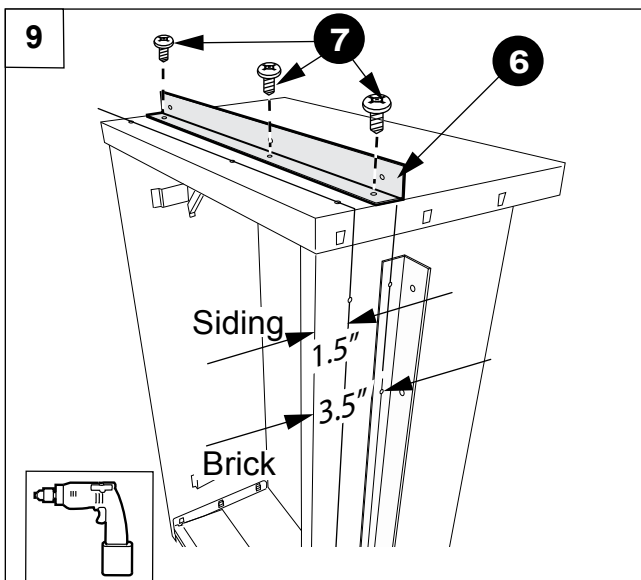
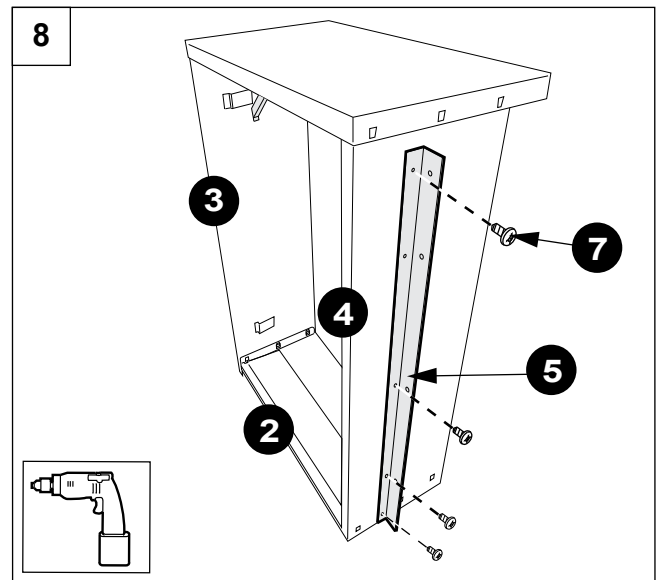
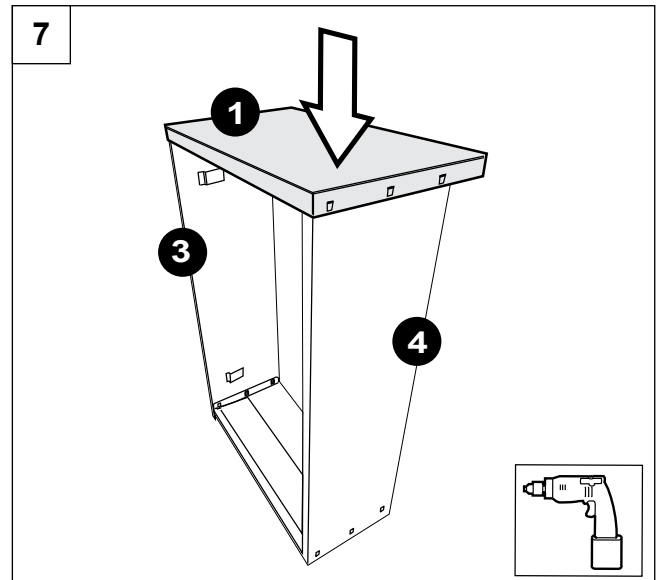

### Wall Sleeve Dimensions

11

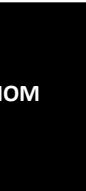
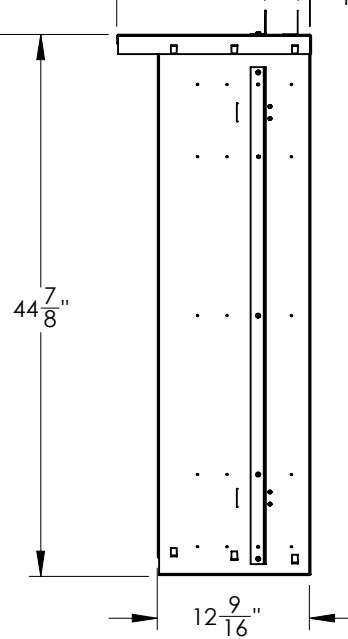
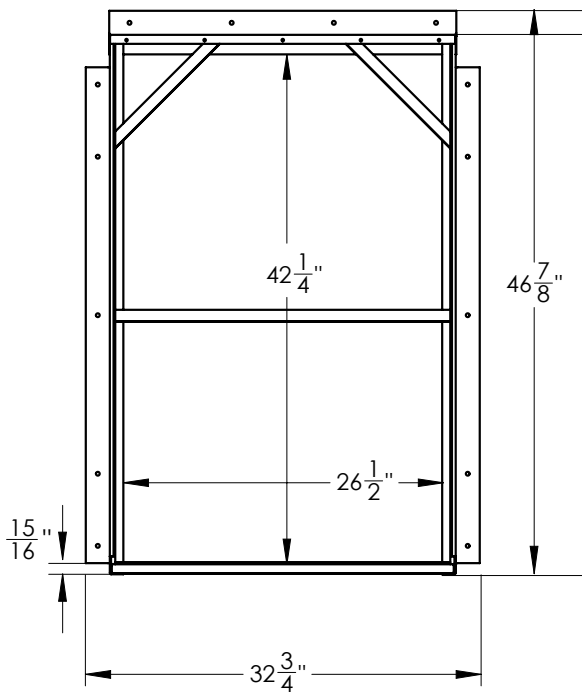
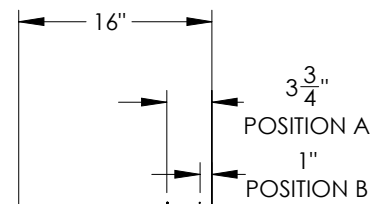
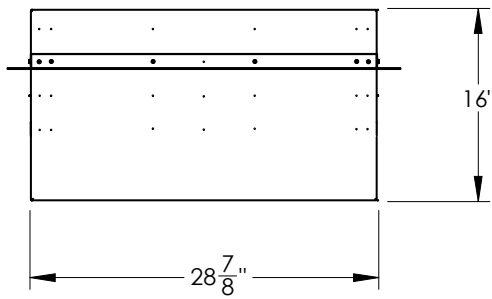
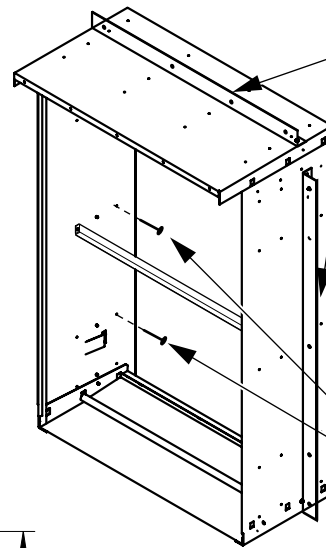

### 4.4.1 Wall Sleeve Installation

## ⚠ WARNING ⚠

**INSTALLATION CREW MUST ADHERE TO ALL LOCAL/NATIONAL SAFE WORK PRACTICES INCLUDING EMPLOYING APPROPRIATE FALL ARREST EQUIPMENT**

#### To install Wall Sleeve into wall opening:

Wall sleeve can be installed from inside (FIG. 12) or outside the building (FIG. 13). The side and top brackets' position need to be adjusted to suit the method and building material.

1. With drain holes facing outside, position the sleeve towards the wall until the support brackets are set on wall edge. Leave ¼ " space in between the wall and sleeve for caulking.
2. Ensure parallel position between Wall Sleeve and wall opening. Wall Sleeve must be square for the CondoPack to slide into it.
3. Attach Wall Sleeve to the building:
  - a. Secure the support brackets to the wall using five screw holes on each side.
  - b. Secure side panels into the structural wall using fasteners.

### ⚠ IMPORTANT ⚠

**SLEEVE MUST BE FASTENED TO THE STRUCTURAL WALL AND NOT TO THE FINISHED WALL.**

4. Completely fill the spaces between the wall sleeve and the wall with Low Expanding Insulation Foam.
5. Wait 8 hours minimum for foam to cure.
6. Prepare the CondoPack unit for installation. For unit support guides refer to "Unit Support" on the next page.
7. Remove wall sleeve squaring braces (10) and (11), FIG 10.
8. Install the unit.
9. Caulk all seams between the wall sleeve and the finished exterior and interior walls. Caulk all seams between the wall sleeve and the cabinet. Seal the spaces using non-hardening caulking compound. All seals must be weather tight to prevent entrance of moisture and water into the building.
10. When installed, the Wall Sleeve should protrude 1/4" to 1" beyond the exterior finished wall to allow proper water evacuation through the drain holes in the bottom panel.

### ⚠ IMPORTANT ⚠

**CARE MUST BE TAKEN NOT TO PLUG THE DRAIN OPENINGS IN THE BASE PANEL.**

11. All openings around the top, sides and bottom of wall sleeve must be caulked and sealed. The wall opening across the top and bottom of the Wall Sleeve could be flashed if required.
12. All unused holes need to be sealed.

12

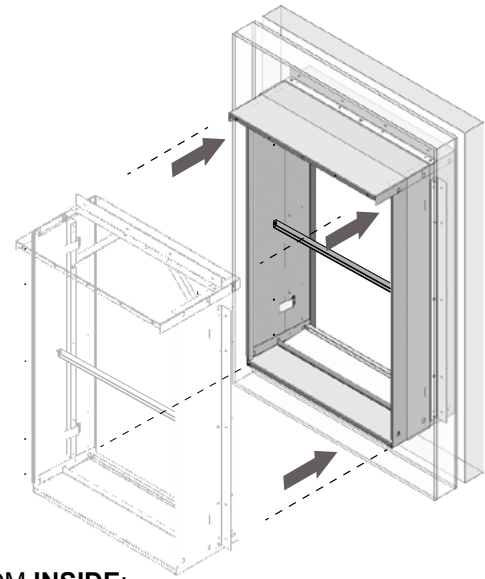

**FROM INSIDE:**

Push the sleeve towards the wall until the support brackets are set on wall edge.

13

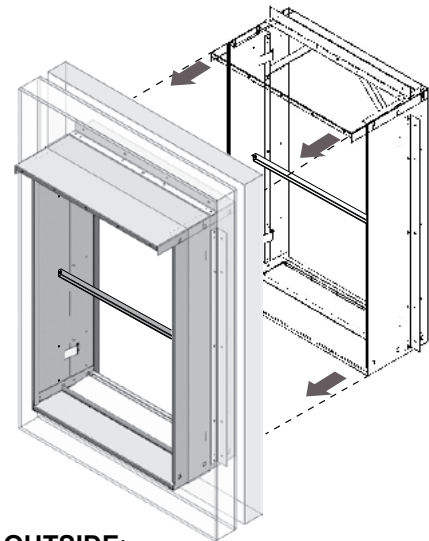

**FROM OUTSIDE:**

Pull the sleeve towards the wall until the support brackets are set on wall edge.



### 4.5 UNIT SUPPORT

The wall sleeve is not intended as the sole support for the unit. Therefore, additional support must be provided by a rigid structure that bears the weight of the unit and provides an interface for "return air" ducting.

- First, the supporting platform must be built, see (FIG. 14). It can be constructed of plywood and framing lumber. (FIG. 15) showing alignment of the platform top with the base panel of the wall sleeve.

- **Minimum height of platform = 8"**
- **Recommended platform width = 29"**
- **Recommended platform depth = 20"**

**Before building support structure, consider the following:**

1. Carefully measure the unit and choose a strong building material for the support structure.
2. The unit should be additionally supported for leveling purposes.
3. An additional vibration isolation material (must be non-combustible) may be used if required.
4. Ensure that the "return air" opening is at least 7"x24". It must be aligned with return air opening on the base of the installed Condo Pack appliance.
5. The support structure and the Wall Sleeve have to provide secure and leveled position for the unit and a method of bringing return air via ducting to the space under the appliance.
6. Flashing the unit to return air duct (bellow the support structure) is to be done later by field installation of Steel Sheet Extensions (custom cut to length). See (FIG 16).

**CAUTION**  
**WEAR SAFETY GLASSES WHEN WORKING WITH TOOLS! OVER-TIGHTENING THE SCREWS MAY STRIP THE RETAINING HOLES. READ ALL OF THE ASSEMBLY INSTRUCTIONS STEPS BEFORE PROCEEDING.**

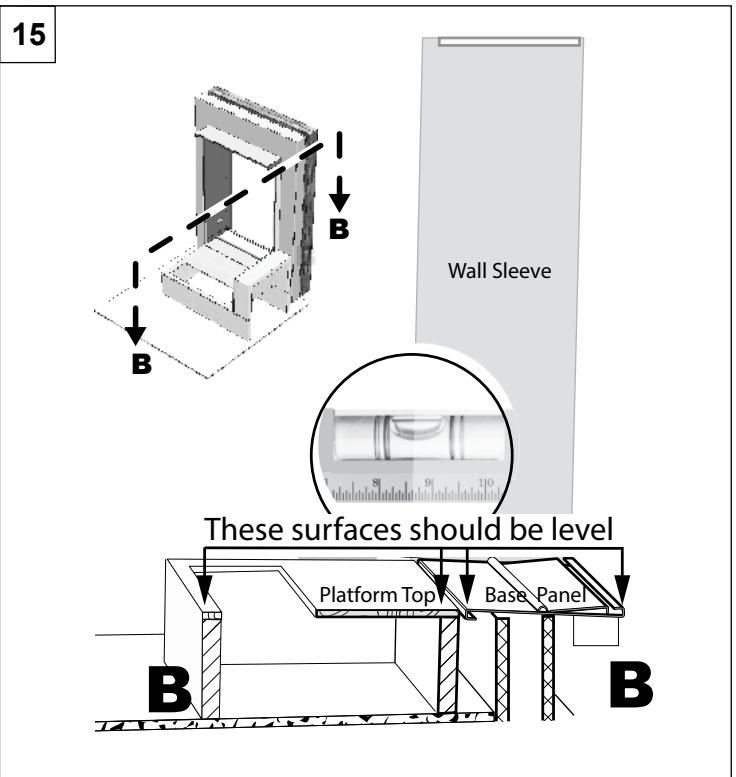
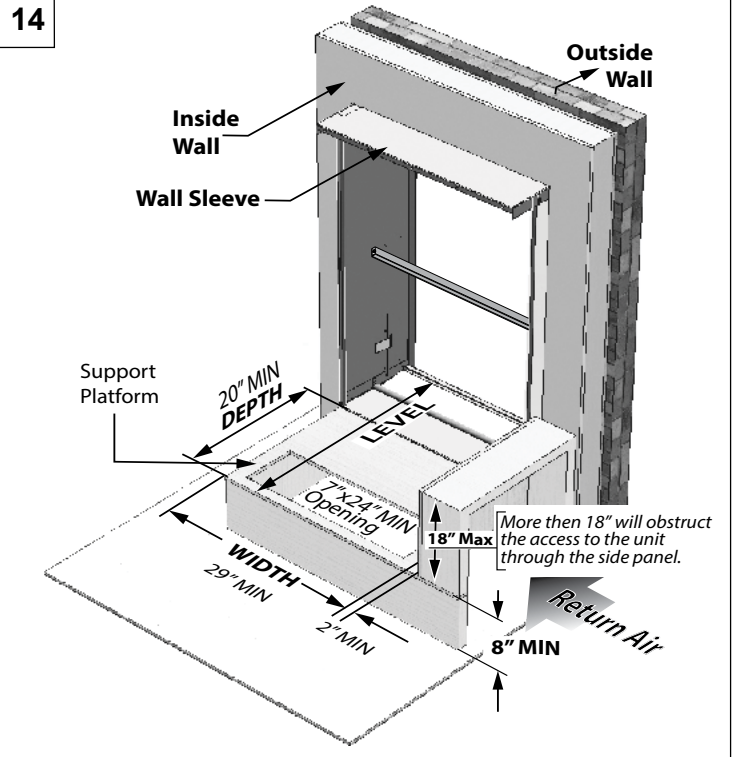

**IMPORTANT**  
**FLASHING MUST SEAL SPACE BETWEEN THE RETURN AIR INLET OF CABINET BASE AND THE RETURN AIR PLENUM TO AVOID DRAWING RETURN AIR FROM THE CLOSET SPACE CONTAINING THE APPLIANCE. REFER TO SECTION 4.7.**

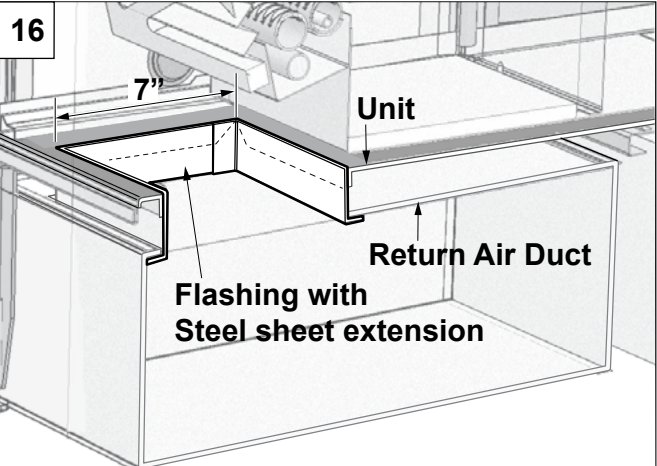

## 4.6 PACKAGED UNIT INSTALLATION

### Procedure

1. Verify that isolation grommets are installed in the five holes on the top mounting bracket.
2. Bring the Condo Pack as close as possible to wall opening (FIG. 4.6.A). Carefully slide the unit into the Wall Sleeve (refer to Wall Sleeve Assembly and Installation Instructions) so the front of the unit is in contact with the front flanges of the Wall Sleeve.

### For ease of installation (OPTIONAL):

- a. Install cabinet into the Wall Sleeve without cooling unit.
- b. Slide cooling unit in, after cabinet is in place (FIG. 4.6.B)
- c. Furnace module also can be removed separately (FIG. 4.6.C). Refer to section "4.16.4.2 Furnace Module Removal".

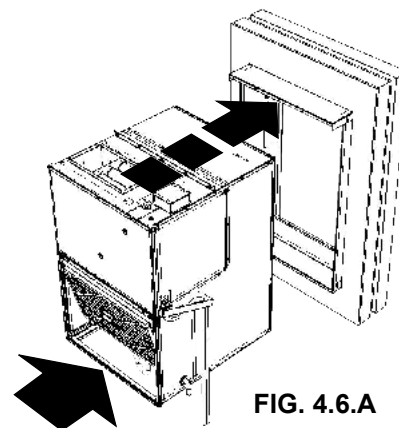

FIG. 4.6.A

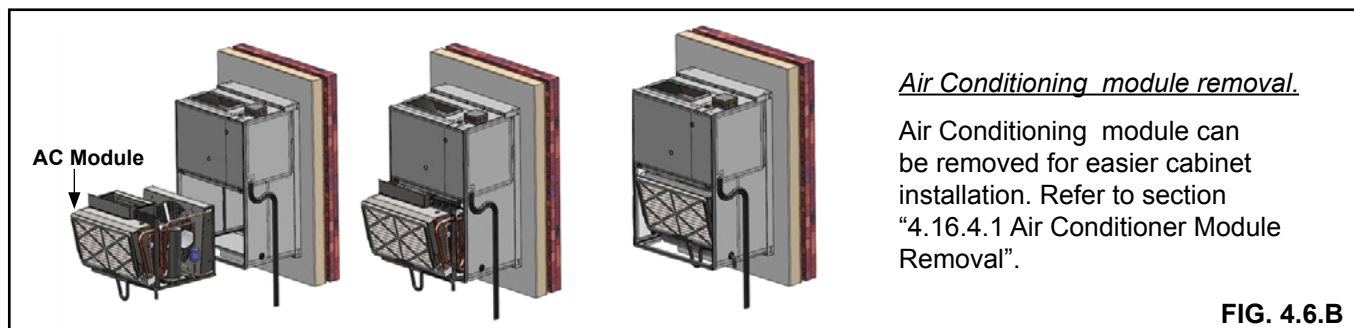

FIG. 4.6.B

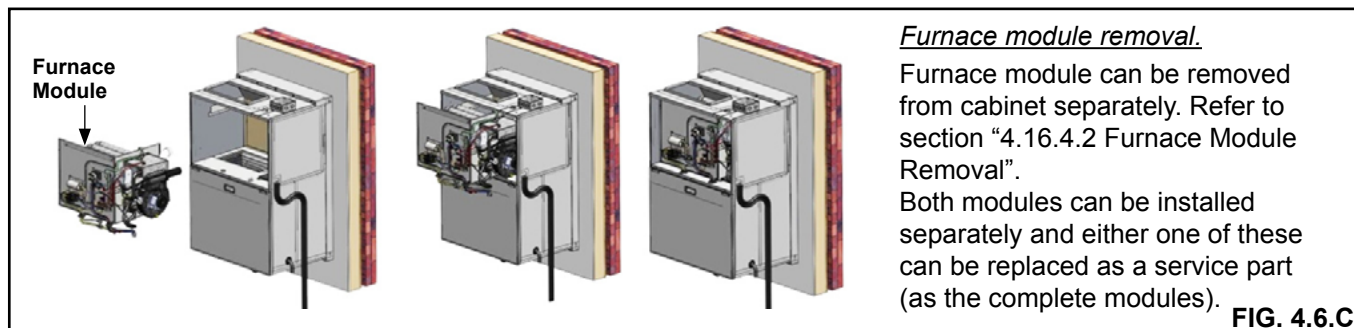

FIG. 4.6.C

3. Use a flat washer with each 1/4"-20 x 1 1/4" screw. Secure Condo Pack unit to the Wall Sleeve using five 1 1/4" screws through the isolation grommets in the five holes on the Wall Sleeve top mounting bracket (see FIG. 4.6.D).

### NOTE

OVER-TIGHTENING THE SCREWS WILL DEFORM THE ISOLATION GROMMETS AND REDUCE THEIR EFFECTIVENESS.

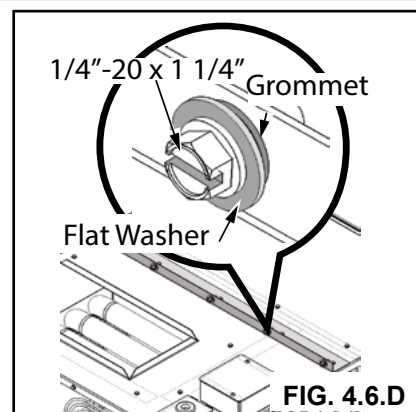

FIG. 4.6.D

4. Caulk and seal all spaces around the top, sides and bottom of the exterior grille area, making sure that the openings for drainage in the bottom edge are not blocked.
5. Shim (FIG. 4.6.E) between unit support (Diagram B) and the bottom rear corners of cabinet to prevent twisting loads onto structural walls.

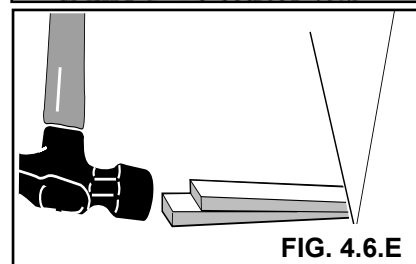

FIG. 4.6.E

## 4.7 DUCTWORK

### 4.7.1 Supply Air Ducting

<b>⚠ IMPORTANT ⚠</b>
<b>BOTH SUPPLY AND RETURN AIR MUST BE DUCTED TO THE APPLIANCE FROM ROOMS SEPARATE TO THE CLOSET ENCLOSURE HOUSING THE APPLIANCE.</b>
<b>SUPPLY AIR DUCT (PLENUM) CONNECTION MUST BE AT LEAST THE SAME SIZE AS THE UNIT SUPPLY AIR OPENING. SEAL SUPPLY AIR DUCTWORK TO UNIT CASING, WALLS, CEILINGS OR FLOORS.</b>

**The ductwork should be sized and constructed in accordance with accepted industry standards:**

The outlet duct may be provided with a removable access panel to view the heat exchanger during unit servicing. Note that a full inspection of the heat exchanger is made possible by the furnace being a “pullout” module. It shall also specify that the cover attachment prevents leaks.

- a. Proper airflow is required for the correct operation of this unit. Insufficient airflow may cause erratic operation, could cause the unit to cycle on the high temperature limit, and may damage the heat exchanger. Excessive airflow may result in an excessively noisy duct system and may result in undesirable consequences such as creating uncomfortable drafts. The total static pressure drop of the air distribution system (including filters) should not exceed 0.5” wc. It is important to provide duct(s) that are sized sufficiently to handle the larger air volumes for heating or cooling provided by this model.
- b. A FLEXIBLE DUCT CONNECTOR is an effective device to prevent the telegraphing of mechanical noise from the furnace to other parts of the home via the ductwork. If using flexible connectors, ensure that the adjoining duct is independently supported.

**Duct sizing and construction information may be obtained from:**

- **A.C.C.A.** (Air Conditioning Contractors of America)
- **A.S.H.R.A.E.** (American Society of Heating, Refrigeration and Air Conditioning Engineers)
- **H.R.A.I.** (Heating, Refrigerating and Air Conditioning Institute (Canada))
- **S.M.A.C.N.A.** (Sheet Metal and Air Conditioning Contractors’ National Association (United States))

All of the above professional organizations have duct sizing manuals available.

<b>⚠ WARNING ⚠</b>
<b>NEVER ALLOW THE PRODUCTS OF COMBUSTION FROM THE FLUE TO ENTER THE RETURN AIR OR SUPPLY AIR DUCTWORK.</b>
<b>⚠ IMPORTANT ⚠</b>
<b>ALL RETURN AIR DUCTWORK MUST BE ADEQUATELY SEALED AND SECURED TO THE UNIT WITH SHEET METAL SCREWS. TAPE THE SHEET METAL SEAMS IN THE VICINITY OF THE UNIT WITH FOIL TAPE OR SIMILAR MATERIAL. WHEN THE UNIT IS MOUNTED ON A PLATFORM WITH RETURN AIR THROUGH THE BOTTOM, IT MUST BE SEALED PROPERLY BETWEEN THE UNIT AND THE RETURN AIR PLENUM.</b>
<b>THE FLOOR OR PLATFORM MUST PROVIDE SOUND PHYSICAL SUPPORT OF THE UNIT WITHOUT SAGGING OR GAPS AROUND THE BASE. IT MUST ALSO BE SEALED BETWEEN THE SUPPORT AND THE BASE.</b>

## 4.7.2 Return Air Ducting

Provide the support inside the building in the area of the return air opening. The support should be high enough to allow for return air to the unit as per requirements.

If required, install a resilient material between the support and the base of the unit to reduce the possible transmission of sound and vibration.

### Unit Flashing

To seal the unit to return air duct (bellow the support structure), perform following procedure steps:

1. Cut a hole in the return air duct (24"x7").
2. Align the unit opening with a return air duct cut out.
3. Insert steel sheet extension part **A** through the opening.
4. Align the upper edges, adjusting the height.
5. Mount to the condo pack using four self-tapping screws provided.
6. Insert second part **B** and mount to extension part **A** using two screws from inside. See cross section **CC** below.

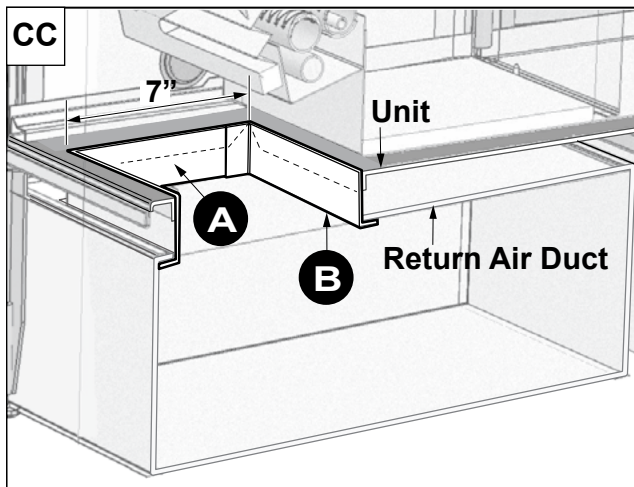

7. Adjust sheet metal extension assembly to the unit opening if necessary and cut off extra sheet length.
8. Secure assembly using four screws **D**.
9. Use Aluminum foil tape to seal all spaces between flashing of return air duct and the unit.

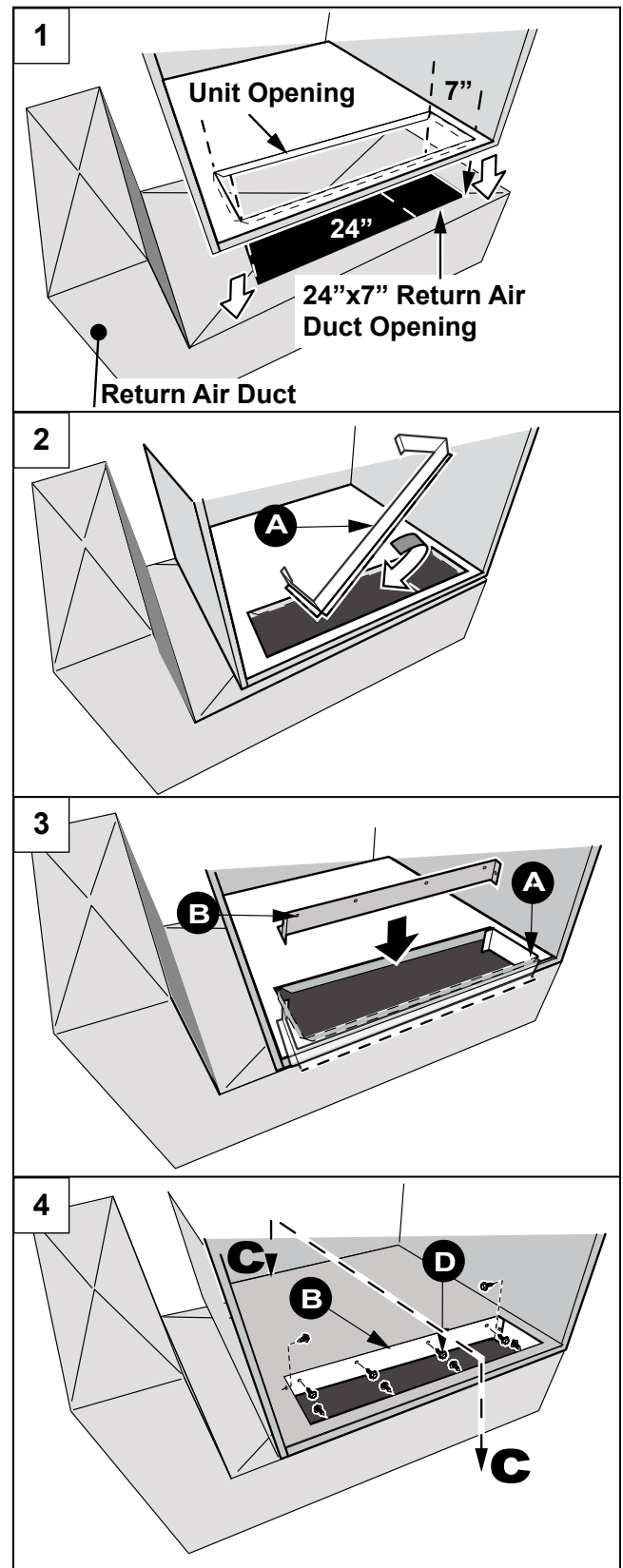



### 4.8 CONDENSATE DRAIN CONNECTION

The furnace and air conditioning condensate drain connections are included, but not installed. Both drain connections are already pre-fabricated with integral P traps. To connect condensate drains to the existing drainage systems, refer to illustrated installation steps 1-11:

**1**  
A - Furnace Hose (1/2" & 5/8")  
B - AC Hose 3/4"

**2**  
C - Hose Clamp 2X  
A - Furnace Hose

**3**  
C - Hose Clamp 1X  
B - AC Hose

**4**  
Pull two clamps C over hose A openings.

**5**  
1. Remove two caps (not shown) from the bottom of barbed T fittings (F).  
Connect hose openings to T fittings and tighten both clamps.

**6**  
Place hose A INSIDE of support bracket D as shown. Mount bracket D into position and secure it with screw provided.

**7**  
Remove both caps E from the top of T fittings F.

**8**  
Prep hose by adding RV grade plumbing antifreeze into both A hose openings until liquid starts dripping from the other end.  
Drain extra liquid.

**9**  
After adding water, **PLACE CAPS BACK** onto barbed T fittings. Check drain hoses inside. Ensure the clamps are tightly clamped to fittings.

**10**  
Add water into drain B opening.  
Drain Extra water.

**11**  
1. Place clamp over hose opening.  
2. Attach hose to AC drain.  
3. Tighten clamp and secure.

**⚠ WARNING ⚠**

CAPS COVERING BARBED FITTINGS SHALL ONLY BE REMOVED DURING PRIMING OF THE P-TRAP. THEY MUST BE FIRMLY IN PLACE COVERING BARBED FITTINGS DURING UNIT OPERATION. IN ADDITION, ALL DRAIN TUBES MUST BE TIGHTLY CLAMPED TO THE BARBED FITTINGS. FAILURE TO FOLLOW EITHER OF THESE CONDITIONS DURING UNIT OPERATION COULD CAUSE EXHAUST PRODUCTS TO ENTER THE LIVING SPACE WHICH MAY RESULT IN PROPERTY DAMAGE, PERSONAL INJURY OR DEATH.

**⚠ CAUTION ⚠** DO NOT drain the condensate outdoors. DO NOT run the condensate line through areas where w might occur. Freezing of condensate can result in erratic operation and in property damage.

**NOTE** The condensate hose leaving the side of the appliance shall follow a downward slope to the building drain at all times. Condensate from the outlet of the drain trap assembly must be conveyed to a floor drain, or to a condensate pump. If using a condensate pump, be sure that it is approved for furnace condensate.

## 4.9 VENTING AND COMBUSTION PIPING

The venting system is an integral part of the appliance and is designed for proper operation under all weather conditions and for winds up to 32 miles per hour. The venting system must not be modified or added on to. The vent outlet must not be altered or extended.

The unit contains an exhaust blower which draws the combustion products out of the heat exchanger together with dilution air and forces the mixture from the unit to the outside. No special provisions are required for supplying air for combustion, nor is a chimney required.

## 4.10 GAS SUPPLY AND PIPING

In Canada, the gas piping should be installed in accordance with CAN/CSA-B149.1 and B149.2, and in accordance with any local codes. In the United States, the gas piping should be installed in accordance with (NFGC) NFPA 54 / ANSI Z223.1 and any local codes.

If local codes allow the use of a flexible gas appliance connector, always use a new listed connector. Do not use a connector which has previously serviced another gas appliance. For a lever-type valve use only a shut-off gas valve approved by CAN/CSA B149.

## 4.11 GAS CONNECTIONS

<b>⚠ IMPORTANT ⚠</b>
<b>ALWAYS USE A BACKSTOP WRENCH TO PREVENT TWISTING OF THE GAS VALVE. ANY STRAINS ON THE GAS VALVE CAN AFFECT POSITIONING OF THE ORIFICES RELATIVE TO THE BURNERS. THIS COULD RESULT IN FAULTY BURNER OPERATION.</b>
<b>ENSURE THAT THE GAS VALVE IS NOT SUBJECTED TO HIGH PRESSURES.</b>
<b>⚠ WARNING ⚠</b>
<b>DISCONNECT THE MANUAL SHUT-OFF VALVE AND GAS VALVE DURING ANY PRESSURE TESTING THAT EXCEEDS 1/2 P.S.I.G. (3.45 kPA).</b>

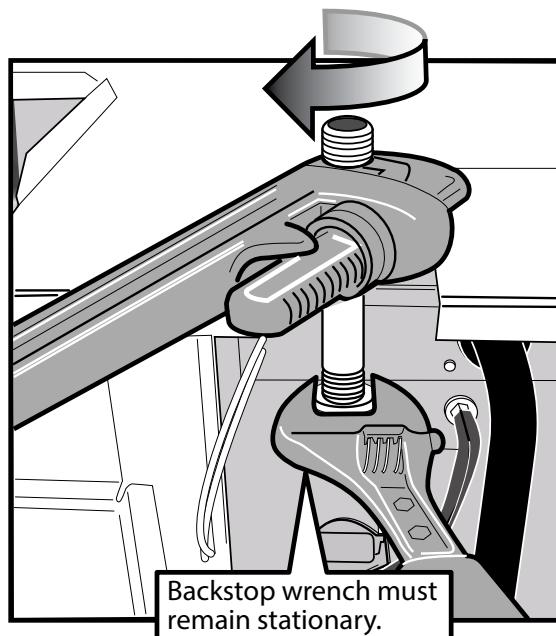

**FIG. 4.11**

## 4.12 GAS INLET PRESSURE

The natural gas inlet supply pressure should be 5" to 7" wc. (7" wc recommended). The LP gas inlet supply pressure should be 11" to 13" wc. (12" wc recommended). These pressures must be maintained while all other gas fired appliances are operating at maximum conditions.

### ⚠ IMPORTANT ⚠

**DO NOT EXCEED 13" WC INLET PRESSURE FOR LP GAS AND 10.5" WC FOR NATURAL GAS.**

The gas valve has an adjustable internal regulator for controlling burner manifold pressure. Burner manifold pressure is listed on the furnace rating plate.

### ⚠ WARNING ⚠

**THE 30, 40 AND 50K BTU FURNACES ARE FACTORY EQUIPPED TO BURN NATURAL GAS ONLY.**

**CONVERSION TO LP GAS REQUIRES A NATURAL GAS TO LP CONVERSION KIT (W370-0040) EXCEPT FOR 15K BTU (CCGM015A) UNITS. THE 15K BTU UNIT COMES FACTORY EQUIPPED TO BURN EITHER NATURAL GAS OR LP GAS. THERE ARE NO CONVERSION KITS FOR THE 15K BTU FURNACE .**

**FAILURE TO USE THE PROPER CONVERSION KIT CAN CAUSE FIRE, EXPLOSION, CARBON MONOXIDE POISONING, PROPERTY DAMAGE, PERSONAL INJURY OR LOSS OF LIFE.**

### ⚠ IMPORTANT ⚠

- **CONVERSION OF THE 30, 40, 50 KBTU FURNACES REQUIRES SPECIALIZED EQUIPMENT. CONVERSION MUST BE COMPLETED BY A TRAINED AND QUALIFIED INSTALLER, SERVICE AGENCY OR GAS SUPPLIER. CONVERSION FROM NATURAL TO LP GAS FOR 15K BTU/H UNITS IS ONLY DONE AT FACTORY.**
- **CONNECT THIS FURNACE ONLY TO GAS SUPPLIED BY A COMMERCIAL UTILITY OR SUPPLIER. PRIVATE GAS WELLS DO NOT GENERALLY PROVIDE GAS WITH CONSISTENT, UNIFORM AND PREDICTABLE HEATING VALUES AND DENSITIES. MANY NON-COMMERCIAL WELLS CONTAIN IMPURITIES SUCH AS SULFUR, WHICH MAY DAMAGE THE FURNACE. THIS FURNACE CANNOT OPERATE PROPERLY OR SAFELY USING FUELS OUTSIDE NORMAL COMMERCIAL STANDARDS.**

In Canada, the gas piping should be installed in accordance with CAN/CSA-B149.1 and 2, and in accordance with any local codes. In the United States, the gas piping should be installed in accordance with (NFGC) NFPA 54 / ANSI Z223.1 and any local codes. If local codes allow the use of a flexible gas appliance connector, always use a new listed connector. Do not use a connector, which has previously serviced another gas appliance.

### ⚠ IMPORTANT ⚠

To maintain a good seal in the burner area, the gas piping through the top panel into the furnace must be 1/2" Schedule 40 black iron pipe. The pipe passes through a special rubber grommet that is custom manufactured to seal tightly around the gas pipe (FIG 4.12.).

### ⚠ IMPORTANT ⚠

Always use a backstop wrench to prevent twisting of the gas valve. Any strains on the gas valve can affect positioning of the orifices relative to the burners. This could result in faulty burner operation.

**ENSURE THAT THE GAS VALVE IS NOT SUBJECTED TO HIGH PRESSURES.**

FIG. 4.12





### 4.13 LEAK TESTING

All new gas piping installations should be pressure tested as specified by CAN/CSA-B149.1 & 2, or NFPA 54 ANSI Z223.1 or ANSI/NFPA 58, "Standard for the Storage and Handling of Liquefied Petroleum Gases."

Gas piping that has not been pressure tested, from the manual shut-off valve to the furnace gas valve for example, should be leak tested using an electronic combustible gas detector, a commercially prepared leak detector, or other locally approved method.

### 4.14 PURGING GAS LINES

Both, the unit and its manual gas shut-off valve must be disconnected from the gas supply piping system during any pressure testing of that system, if test pressure exceeds 1/2 psi (3.5 kPa).

<b>⚠ WARNING ⚠</b>
<b>FIRE OR EXPLOSION HAZARD! NEVER TEST FOR GAS LEAKS WITH AN OPEN FLAME. NEVER USE A MATCH, TAPER, CIGARETTE LIGHTER, FLAME OR ANY OTHER IGNITION SOURCE TO CHECK FOR LEAKS IN A GAS LINE.</b>
<b>USE A COMMERCIALY AVAILABLE SOAP SOLUTION MADE SPECIFICALLY FOR THE DETECTION OF LEAKS TO CHECK ALL CONNECTIONS.</b>
<b>FAILURE TO ADHERE TO THIS WARNING CAN CAUSE A FIRE OR EXPLOSION RESULTING IN PROPERTY DAMAGE, PERSONAL INJURY, OR LOSS OF LIFE.</b>

### 4.15 CONVERSIONS

#### 4.15.1 High altitude conversion

In Canada, unit is certified up to 4500 feet with no de-rate for Natural gas only. LP (propane) requires a 10% reduction of input capacity for elevating from 2000 - 4500 feet (610m - 1372m).

In the United States, the modifications for high altitude are based on a 4% reduction of input capacity for every 1000 feet (305m) above 2000 feet (610m) above sea level. Consult with local fuel suppliers or authorities to determine local regulations or customs.

#### 4.15.2 Natural to LP Gas Conversion

<b>NOTE</b>
• THIS PROCEDURE DOES NOT APPLY TO 15K BTU/h UNITS (CCGM015A).

This unit is manufactured as a natural gas appliance that may be converted to LP gas through the use of the **Conversion Kit (W370-0040)**. This kit contains the conversion kit instructions, orifices needed for all models, the regulator spring for the gas valve, and a label to affix adjacent to the appliance rating plate to alert subsequent service technicians of the conversion. The parts removed for this conversion must remain with the furnace for any future conversion back to natural gas.

#### 4.15.3 Checking the Inlet Gas Pressure

##### WHITE-RODGERS 36J24-214 / 36J24-218P1 SINGLE STAGE GAS VALVE

1. Turn off the gas and electrical supply to the furnace.
2. Back off inlet pressure test screw (inlet pressure boss, see FIGURE 28 & 29) counterclockwise out one turn maximum, with a 3/32" Allen wrench. Attach a hose and calibrated U-tube or digital manometer to the inlet pressure boss. Hose should overlap boss 3/8". The manometer must have a scale range of at least 0" to 15" of water column.
3. Turn ON the gas and electrical supply and operate the furnace and all other gas consuming appliances on the same gas supply line. Using a leak detection solution, check for leaks around the gas valve/manifold connection and the burner orifices. Repair any leaks before continuing.
4. Measure furnace gas inlet pressure with burners firing. Inlet pressure must be within the range specified on the furnace rating plate. 5-7" w.c. (Natural Gas) or 11-13" w.c. (LP).

If the inlet pressure differs from the rating plate, check the gas piping size and/or consult with local gas utility. If working on a natural gas system, contact the gas utility. They may insist on any service regulator adjustments being made by their own staff.

5. Turn off gas and electrical supply to furnace, remove the manometer hose from the inlet pressure tap boss, and tighten the inlet pressure tap screw using the 3/32" Allen wrench. (Clockwise, 7 in-lb minimum).
6. Turn on the gas supply and electrical power to the furnace.
7. Using a leak detection solution, check for leaks at pressure boss screw. Bubbles forming indicate a leak. SHUT OFF GAS AND FIX ALL LEAKS IMMEDIATELY!
8. Turn gas back on and test inlet pressure boss with leak detector.

If problems were encountered with obtaining enough pressure, first examine the gas piping system to ensure that it is correctly sized. Pipe sizing is specified in CAN/CSA-B-149.1 & 2, and in NFPA 54 / ANSI Z223.1. Be sure to check for restrictions, partially closed valves, etc.

In some circumstances, high inlet pressure can be remedied with the use of an in line appliance regulator. If an in line appliance regulator is used, ensure that it has the capacity to adequately handle the gas volume required by the furnace and any other appliances receiving gas from the header serving the furnace.

H18.4.1A

FIG. 28. - WHITE RODGERS 36J24-214 GAS VALVE

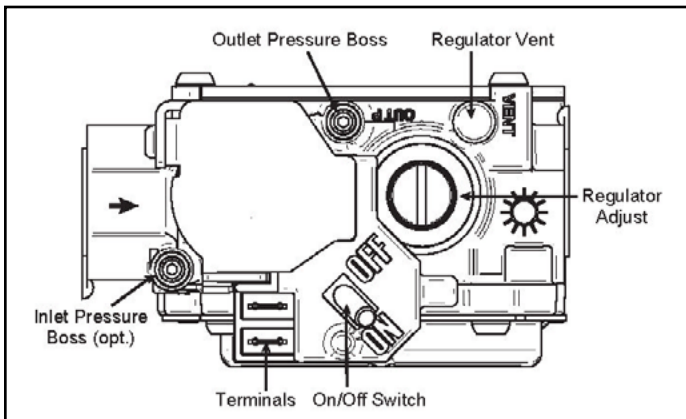
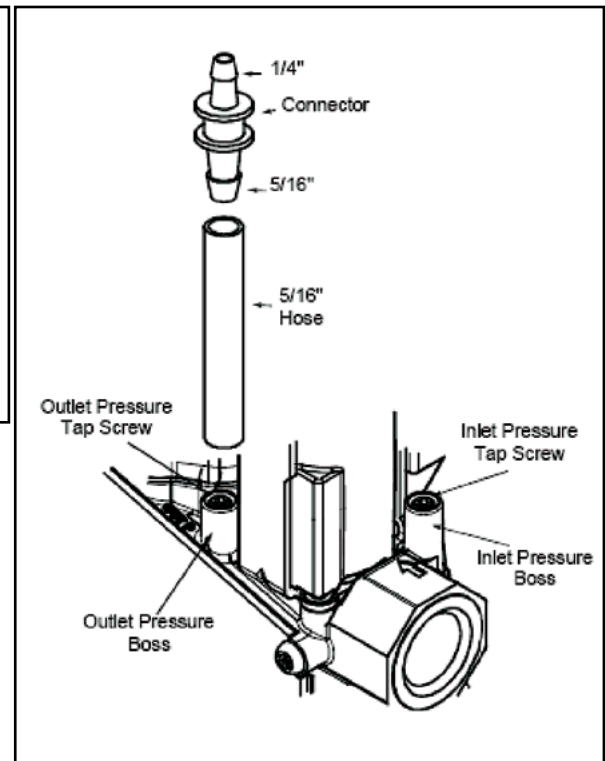

FIG. 29. VALVE PRESSURE CHECK KIT



#### 4.15.4 Setting the manifold pressure

When the installation is completed to the "Start-up & Setup" stage, test the gas manifold pressure by following these steps:

##### WHITE-RODGERS 36J24-214 SINGLE STAGE GAS VALVE

1. Turn off the gas and electrical supply before proceeding.
2. Back off outlet pressure test screw (outlet pressure boss, see fig. 28 & 29) counterclockwise out one more turn maximum, with a 3/32" Allen wrench. Attach a hose and a calibrated U-tube or digital manometer to the outlet pressure boss. Hose should overlap boss 3/8". The manometer must have a scale range of at least 0" to 15" of water column.
3. Turn on the gas supply and electrical power to the furnace and energize main solenoid by connecting R to W on the integrated control board.

4. Remove screw from the outlet pressure regulator adjust tower (fig.28) and turn the plastic regulator adjustment screw clockwise to increase manifold pressure or counterclockwise to reduce manifold pressure. Manifold pressure should be set to 3.5" w.c for natural gas, 10.5" w.c. for LP gas. Always adjust regulator according to original equipment manufacturer's specifications listed on the appliance rating plate. When the correct pressure has been established, securely replace the regulator cover screw. **FAILURE TO DO SO LEADS TO FIRE DANGER!**
5. Turn off the gas and electrical supply to the furnace.
6. Remove the manometer hose from the outlet pressure tap boss, and tighten the outlet pressure tap screw using the 3/32" Allen wrench. (Clockwise, 7 in-lb minimum).

## ⚠ WARNING ⚠

**ALL REGULATOR ADJUSTMENTS MUST BE DONE BY A TRAINED, QUALIFIED TECHNICIAN. IMPROPER MODIFICATIONS OR ADJUSTMENTS CAN RESULT IN FIRE OR EXPLOSION CAUSING PROPERTY DAMAGE, SEVERE PERSONAL INJURY OR LOSS OF LIFE.**

H3.21

7. Turn on the gas supply and electrical power to the furnace.
8. Turn on system power and energize valve.
9. Using a leak detection solution, check for leaks at pressure boss screw. Bubbles forming indicate a leak. **SHUT OFF GAS AND FIX ALL LEAKS IMMEDIATELY!**

### 4.15.5 Checking furnace input

The natural gas supply pressure should be a maximum of 7" wc and minimum of 5" wc. The burner manifold pressure is factory set to 3.5" wc. The input rating of the furnace is based on 1000 Btu/ft<sup>3</sup> gas. Since heating values for the gas vary geographically, the actual furnace input and output will vary accordingly. For example, natural gas with a 900 Btu/ft<sup>3</sup> heating value will reduce the input to 90% of the rated input. Natural gas with a 1100 Btu/ft<sup>3</sup> heating value will increase the input to approximately 110% of the rated input. This is not usually a problem; however, adjustments to compensate for this can be made by minor adjustments to the burner manifold pressure or by changing the burner orifice size. Contact the fuel supplier for specific heating content values.

Any adjustments to the burner manifold pressure should be carried out with the use of a manometer or calibrated Magnehelic® gauge. Do not adjust the gas valve pressure regulator more than ±0.3" wc. Refer to: *Setting The Manifold Gas Pressure and Figure 30.*

## ⚠ IMPORTANT ⚠

**NEVER ADJUST THE INPUT OF THE FURNACE TO EXCEED THE INPUT SHOWN ON THE RATING PLATE.**

**FIG. 30. - MANOMETER MEASURING GAS MANIFOLD PRESSURE**

$$\text{INPUT} = \frac{\text{HEATING value of gas} \times 3600}{\text{TIME in sec. for 1 CU. FT.}}$$

where:

- **INPUT** is expressed in btu/hr
- **HEATING** value of the gas is expressed in btu/ft<sup>3</sup>
- and **TIME** is the number of seconds required for the test dial to indicate 1 cubic foot.

If using a gas meter with SI (metric) units:

- 1 cubic foot = 0.0283 cubic meters
- 1 cubic meter = 35.315 cubic feet
- 0.01 cubic meter = 0.3531 cubic feet
- 0.5 cubic meter = 1.766 cubic feet



H18.6.1\_AC

## 4.16 ELECTRICAL

### ⚠ WARNING ⚠

**ALL ELECTRICAL WORK MUST BE DONE BY A TRAINED, QUALIFIED TECHNICIAN. IMPROPER MODIFICATIONS OR ADJUSTMENTS CAN RESULT IN FIRE OR EXPLOSION, CAUSING PROPERTY DAMAGE, SEVERE PERSONAL INJURY OR LOSS OF LIFE.**

- In Canada, all electrical work and grounding must be in accordance with the latest edition of CSA-C22.1, Canadian Electrical Code Part 1, and any applicable local code. In the United States, all electrical work must be in accordance with the latest edition of the National Electrical Code, ANSI / NFPA 70.
- The operating voltage of the unit is from 197 to 253 volts. Operating the equipment outside of these limits will void the warranty.
- The wiring diagram is located behind the furnace access panel.
- Ensure that electrical components in the indoor section are protected from water.

The rating plate indicates the operating voltage, phase, ampacity, maximum fuse size, and minimum voltage. Refer to the rating plate located on the unit for proper fuse or breaker size.

### 4.16.1 Electrical Wiring And Connections

#### 4.16.1.1 Main Disconnect Switch

Before proceeding with the electrical connections, ensure that the available electrical supply is compatible with the voltage, frequency and phase listed on the appliance rating plate.

It is NOT permissible to connect unit to accessories such as humidifier transformers, condensate pumps and electronic air cleaners.

### ⚠ WARNING ⚠

**PROVIDE EACH CONDOPACK UNIT WITH ITS OWN SEPARATE ELECTRICAL CIRCUIT, MEANS OF CIRCUIT PROTECTION, AND ELECTRICAL DISCONNECT SWITCH. FOLLOW CURRENT NATIONAL ELECTRICAL CODE ANSI/NFPA 70, CSA C22.1 C.E.C. PART 1, AND STATE AND LOCAL CODES. FAILURE TO PROVIDE THESE SHUT-OFF MEANS COULD CAUSE ELECTRICAL SHOCK OR FIRE, RESULTING IN DAMAGE, INJURY OR DEATH.**

### ⚠ WARNING ⚠

**SHUT OFF ELECTRICAL POWER AT THE FUSE BOX OR SERVICE PANEL BEFORE MAKING ANY ELECTRICAL CONNECTIONS. FAILURE TO DO SO CAN CAUSE ELECTRICAL SHOCK RESULTING IN PERSONAL INJURY OR LOSS OF LIFE.**

- THE FURNACE CABINET MUST HAVE AN UNINTERRUPTED GROUND.
- A GROUND WIRE IS PROVIDED IN THE ELECTRICAL JUNCTION BOX.
- DO NOT USE GAS PIPING AS A GROUND.

**FAILING TO GROUND THE FURNACE PROPERLY CAN RESULT IN ELECTRIC SHOCK RESULTING IN PERSONAL INJURY OR DEATH.**

#### 4.16.2.1 Service Switch

It is mandatory to supply unit with a disconnect switch located BEFORE the unit, making sure that one does not have to pass the unit perimeter in order to disconnect power to the unit.

Although is not necessary, but is recommended that rooms with more than one entrance are equipped with a separate unit disconnect switch, located close the room entrance.

**⚠ IMPORTANT ⚠**

**THE SERVICE SWITCH SHOULD BE CLEARLY LABELED AND INSTALLED IN A LOCATION WHERE IT IS NOT LIKELY TO BE MISTAKEN AS BEING A LIGHT SWITCH OR SIMILAR CONTROL.**

#### 4.16.2 Unit Connection

The unit is shipped fully wired except for the connections to the house wiring. The unit power connections are made in a junction box located on the top of the cabinet (refer to Figure 4.0). The junction box contains a BLACK wire to be connected with L1 (hot), a WHITE wire to be connected with L2 (Neutral), and a GROUND LUG to be connected to the ground.

**NOTE**

Use good quality wire nuts such as Marrette® connectors, Ideal® wire nuts, etc.

**⚠ IMPORTANT ⚠**

**USE COPPER CONDUCTORS ONLY.**

H19.3

4.16.3 Wiring Diagram

WIRING DIAGRAM / SCHÉMA DE CÂBLAGE

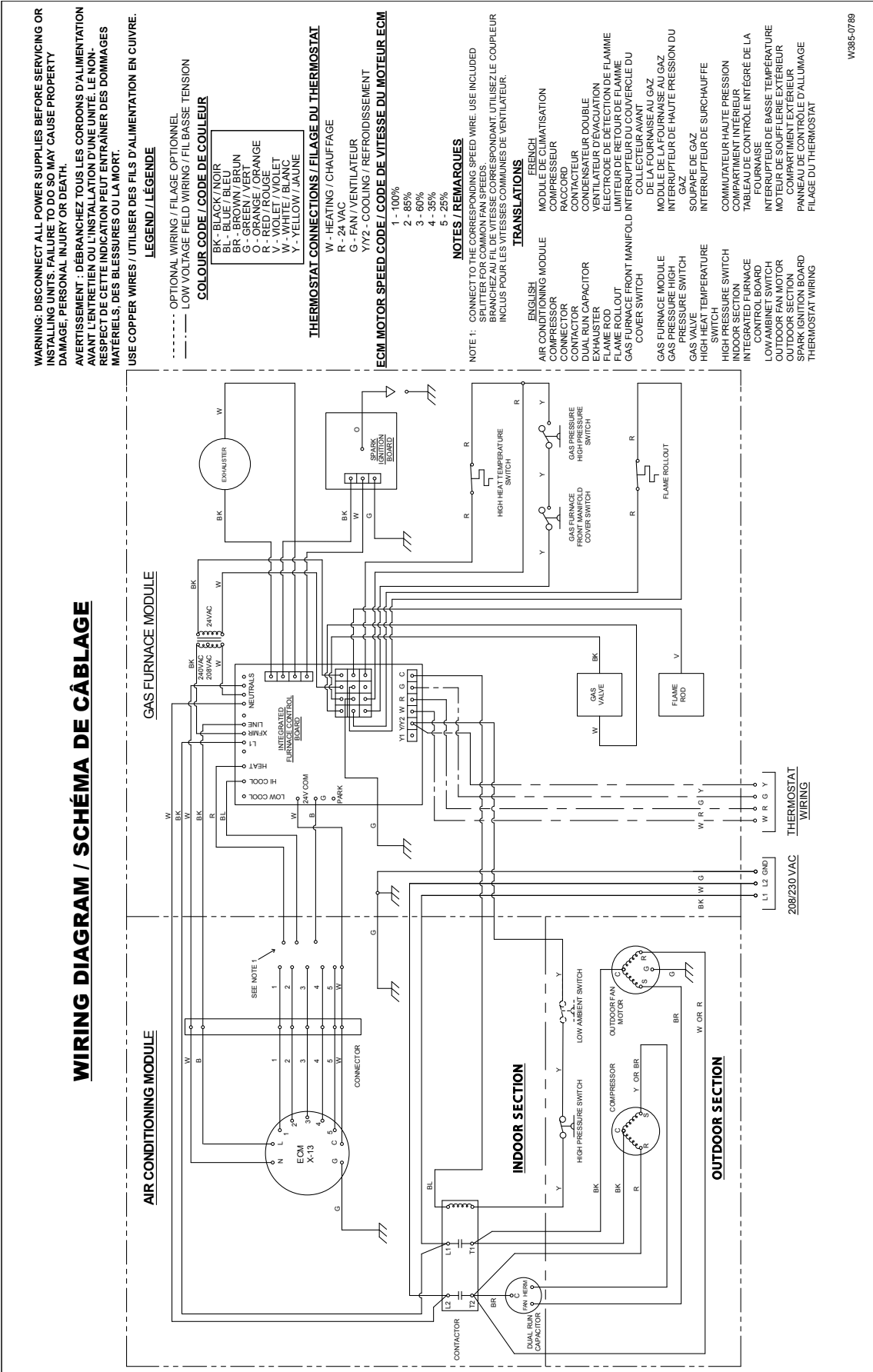

W385-0789



4.16.4 Removal of Air Conditioner and Furnace Modules

IOM

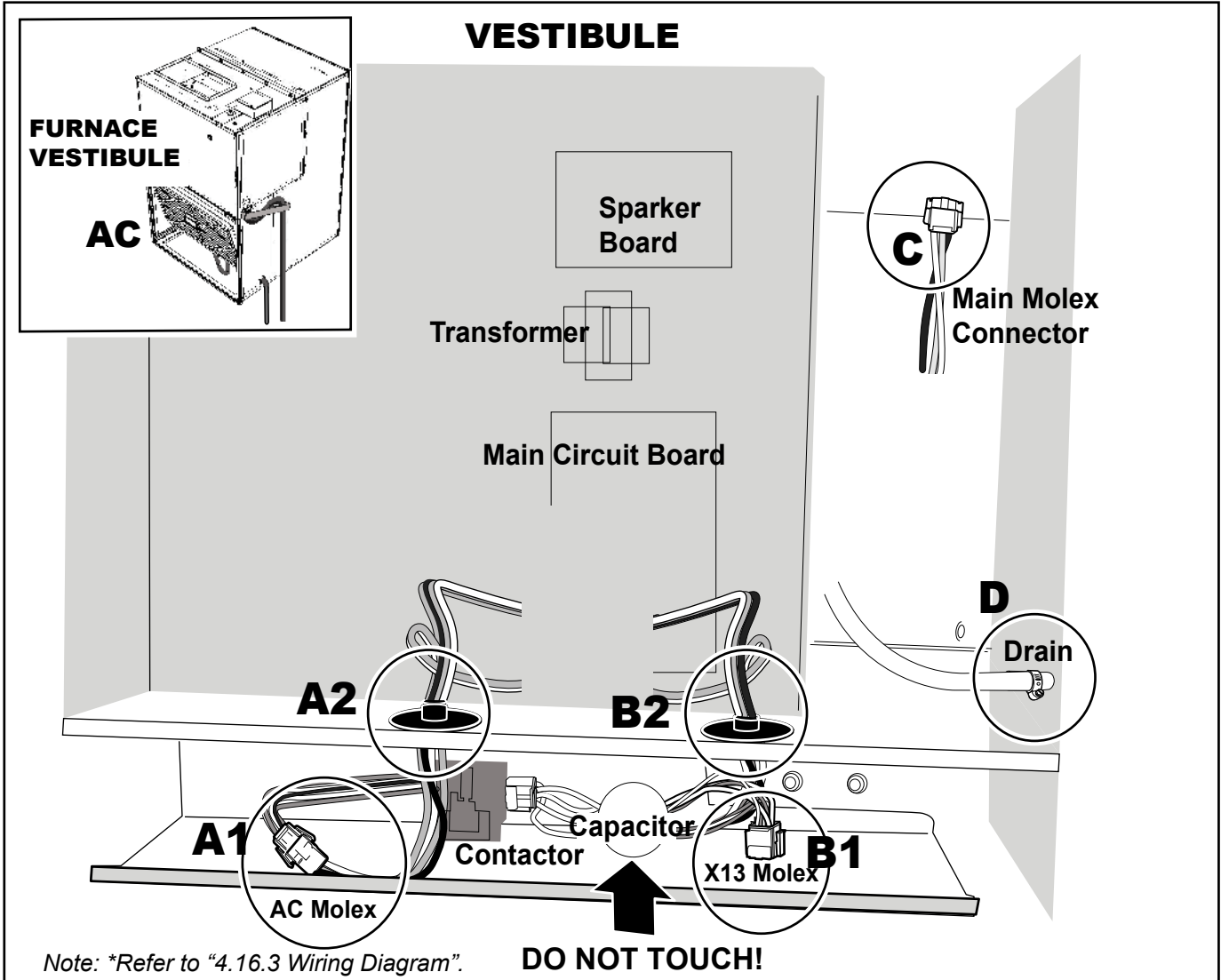

**⚠ WARNING ⚠**

**ALL ELECTRICAL WORK MUST BE DONE BY A TRAINED, QUALIFIED TECHNICIAN. IMPROPER MODIFICATIONS OR ADJUSTMENTS CAN RESULT IN FIRE OR EXPLOSION CAUSING PROPERTY DAMAGE, SEVERE PERSONAL INJURY OR LOSS OF LIFE.**

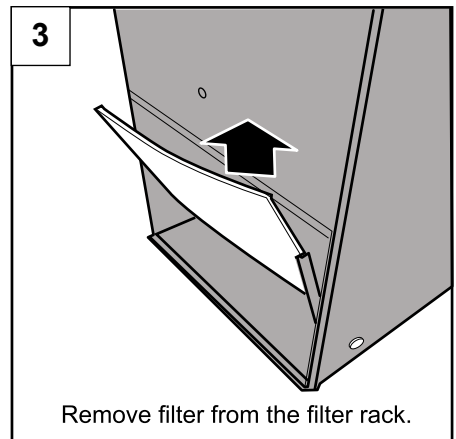
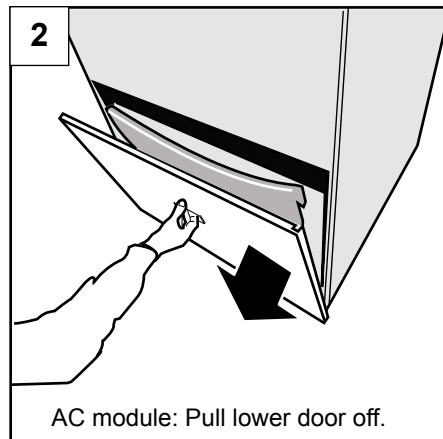
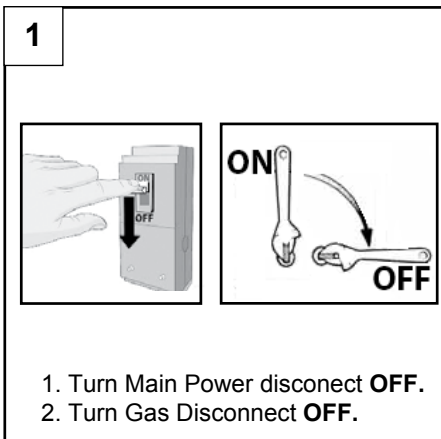

### 4.16.4.1 Air Conditioner Module Removal

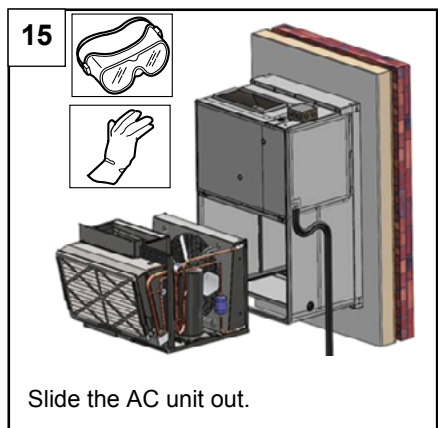
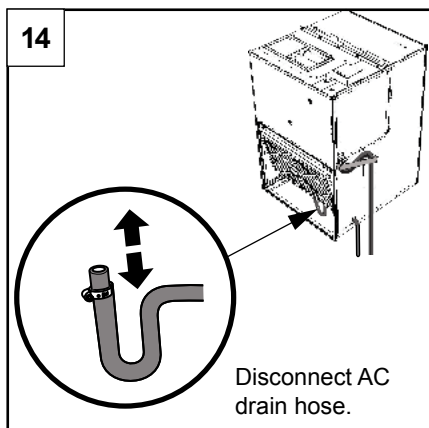
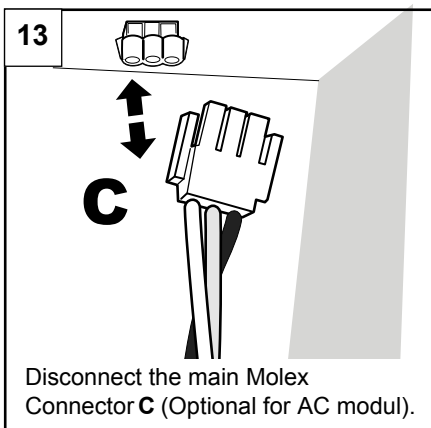
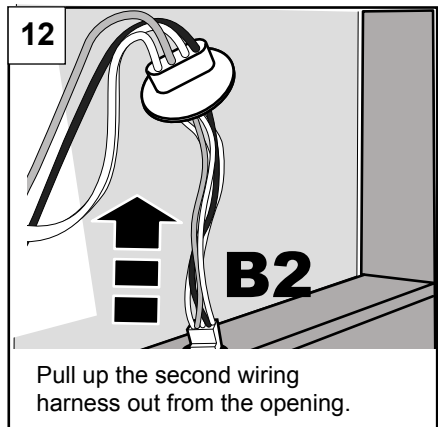
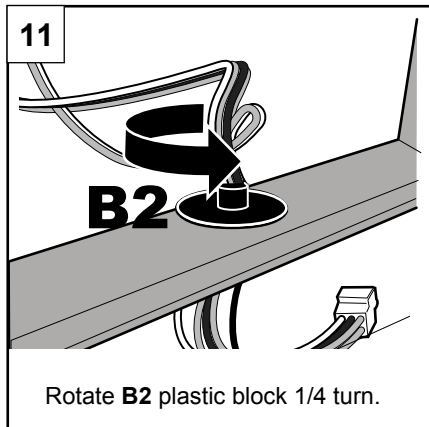
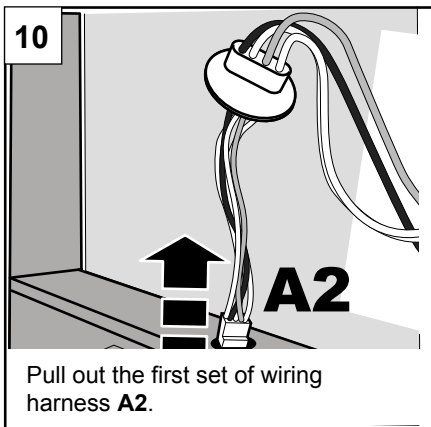
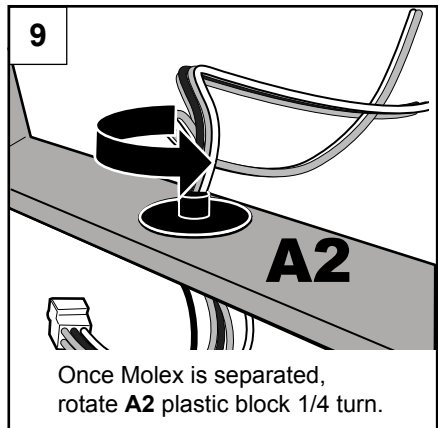
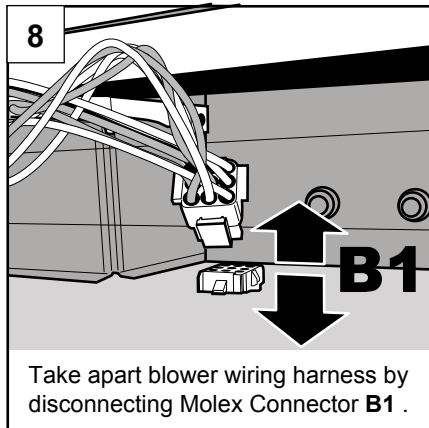
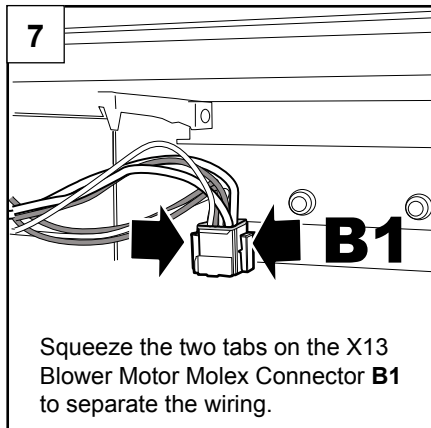
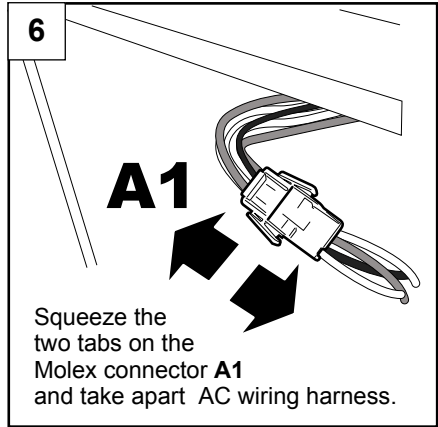
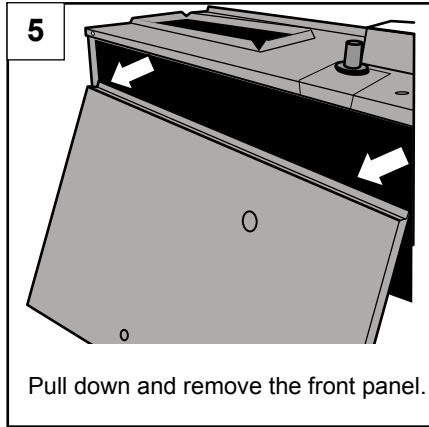
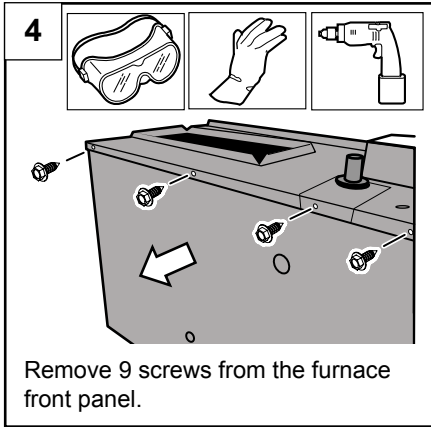

**4.16.4.2 Furnace Module Removal**

**16**

Remove 9 screws from the furnace front panel.

**17**

Pull down and remove the front panel.

**18**

Squeeze the two tabs on the Molex connector **A1** and take apart AC wiring harness.

**19**

Squeeze the two tabs on the X13 Blower Motor Molex Connector **B1** to separate the wiring harness.

**20**

Take apart blower wiring harness by disconnecting Molex Connector **B1**.

**21**

Once Molex is separated, rotate **A2** plastic block 1/4 turn.

**22**

Pull out the first wiring harness **A2**.

**23**

Rotate **B2** plastic block 1/4 turn.

**24**

Pull up the second set of wiring harness out from the opening.

**25**

Disconnect the main Molex connector **C**.

**26**

Gas Shutt OFF valve  
Union  
T - Connector  
°90 - Connector  
Drip Cap  
6" Piping 1/2" Nipple supplied  
Condo Pack

**27**

1. Turn gas OFF.
2. Disconnect Union connector.
3. Remove gas piping downflow from Union connector.
4. Remove °90 connector from 6" nipple (supplied on GAS module).
5. Disconnect drain trap hoses.
6. Disconnect a thermostat.
7. Slide the Heating Module out.

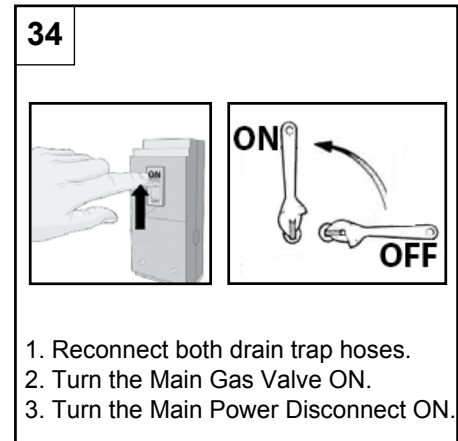
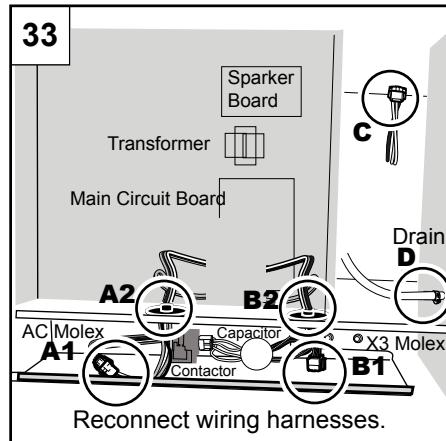
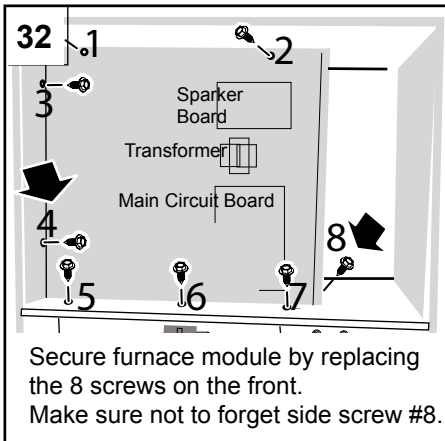
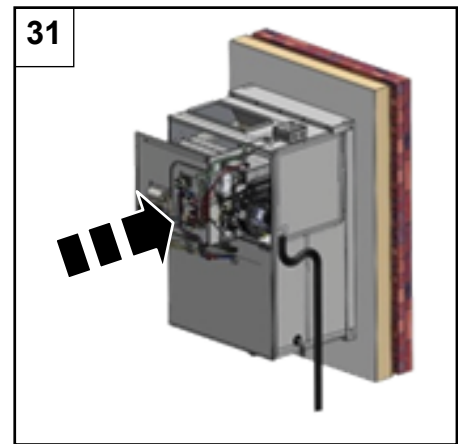
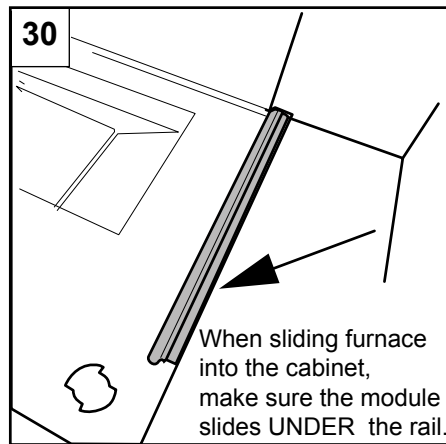
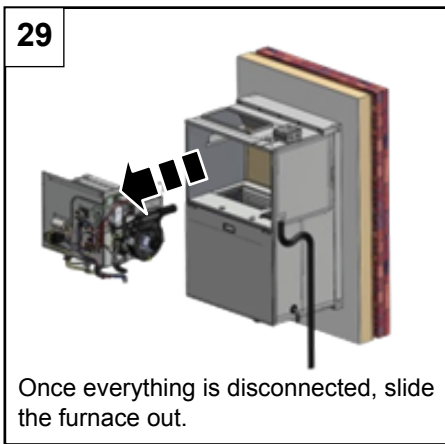
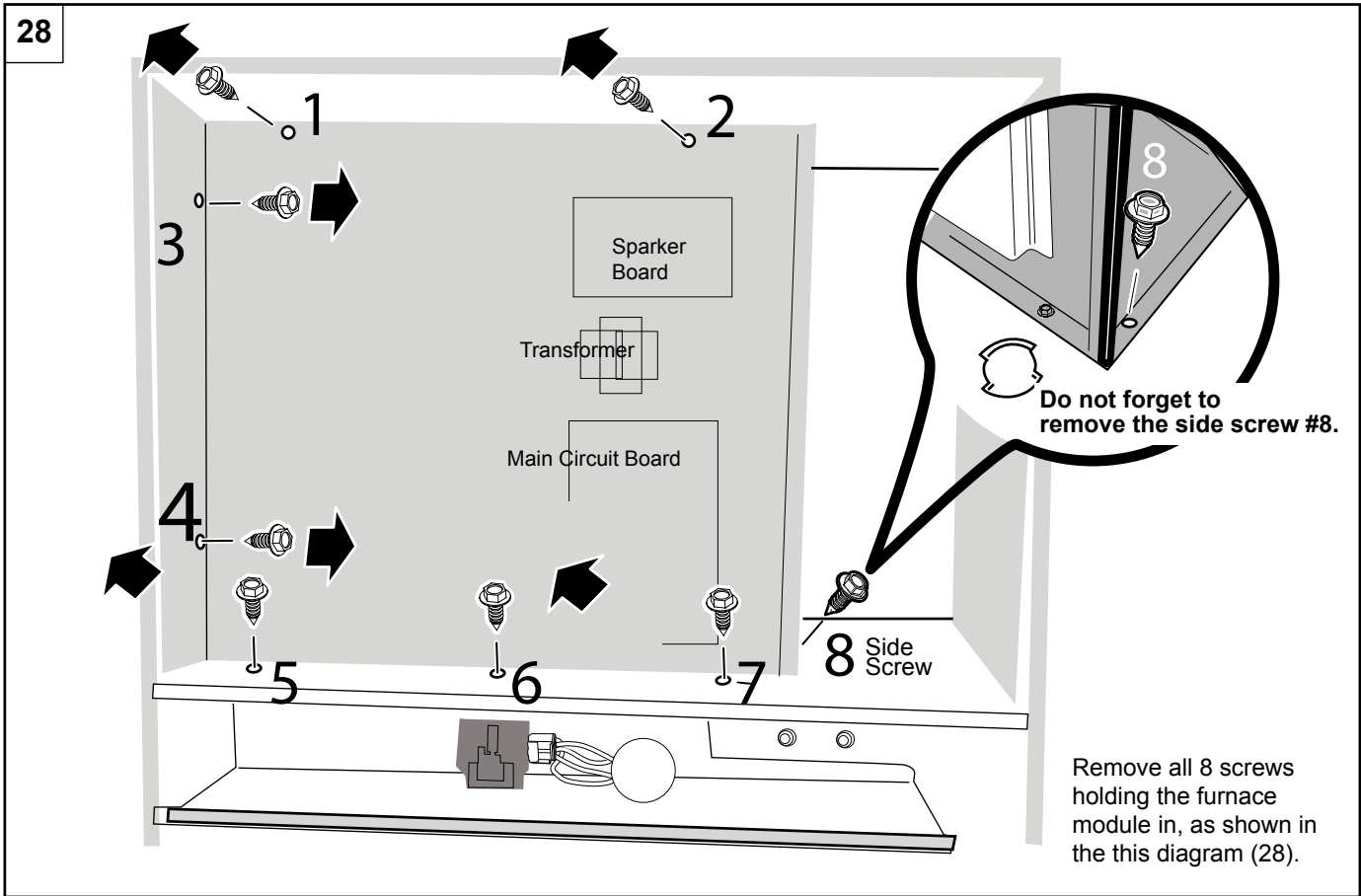

#### **4.16.5 Low Voltage Wiring**

The thermostat and control wiring should be a minimum of 18 AWG copper. Excessive lengths of wire may result in enough voltage drop to impair the proper functioning of the furnace. For thermostat wires in excess of 25 feet (7.6m), use 16 AWG; 50 feet (15.2m), use 14 AWG.

---

H53.1

#### **4.16.6 Thermostat**

The thermostat should be located approximately 5 feet (1524mm) above the floor, on an inside wall where there is good natural air circulation, and where the thermostat will be exposed to average room temperatures. Avoid locations where the thermostat will be exposed to cold drafts, heat from nearby lamps or appliances, exposure to sunlight, heat from inside wall stacks, etc.

---

H53.2

#### **4.16.7 Blower**

The unit contains a direct-drive, multi-speed blower. The proper speeds have been preset at the factory for heating and cooling. For recommended heating/cooling speeds for specific models refer to Table 4. in "5.4.1 Temperature Rise Check" section. Direct-drive blower motors are permanently lubricated and do not require oiling.

#### **4.16.8 Limit Control**

A fixed temperature limit control is provided which will shut off the gas to the main burners if the unit is overheated for any reason. The control must not be adjusted or relocated.

#### **4.16.9 Installation and Operation in Extremely Cold Weather Areas**

In areas where extremely cold (below 20°F) outdoor temperatures can be expected, some additional installation and operating precautions should be taken. The following precautions are taken to prevent possible vent system ice blockage that could result in safety shutdown of the burners:

1. Adjust to the highest achievable temperature rise within the rise and static pressure ranges specified on the rating plate. Depending on specific model, it may be possible to change to a lower heating blower speed tap to get a higher temperature rise.
2. Make sure there are no leaks of outside air into the return air system.
3. Keep the outside louver grille as free as possible of any ice that may form and obstruct the flue outlet.

## 5. STARTUP AND SHUTDOWN

The Condo Pack is designed to be used with residential single-stage cooling and single-stage heating wall thermostats with automatic or manual mode changeover. Automatic changeover thermostats must include a deadband to prevent cycling between cooling and heating modes. Single-pole, single-throw thermostats are not suitable for use with Condo Pack. The unit incorporates a 90-second time delay to keep the indoor blower operating after cooling is satisfied to reduce operating costs. Indoor blower motor speed for cooling and heating modes can be altered by changing the motor speed taps on the Endura Pro Motor harness.

### 5.1 FURNACE STARTUP

This furnace is equipped with a spark ignition (SI) device. Each time that the room thermostat calls for heat, the SI lights the main burners directly. See the lighting instructions on the furnace.

When the gas supply is initially connected to the furnace, the gas piping may be full of air. In order to purge this air, the installer must use purging equipment and techniques as listed in National and Local Gas codes. Allow five minutes for any gas to dissipate before continuing with the start-up procedure. Be sure proper ventilation is available.

During initial start-up, it is not unusual for odor to come out of any room register. To ensure proper ventilation, it is recommended to open windows and doors, before initial firing.

The furnace has a negative pressure switch that is a safety during a call for heat. The induced draft blower must pull a negative pressure on the heat exchanger to close the negative pressure switch. The induced draft blower must maintain at least the negative pressure switch set point for the furnace to operate. If the induced draft blower fails to close or maintain the closing of the negative pressure switch, a “no heat call” would result.

#### NOTE

It is required/mandatory that the drain trap assembly be primed before the initial startup. Refer to the instructions on how to prime the condensate trap on the drain piping section in this manual. A dry trap will allow flue gases to flow through the recovery coil drain, which will prevent the condensate from draining from the recovery coil. If enough condensate accumulates in the recovery coil, the recovery coil pressure switch will sense this condition and break its electrical contacts, and extinguish combustion. If this takes place, the induced blower will stop after a brief post-purge cycle, the condensate will drain out and fill the trap. If the thermostat is still calling for heat, the ignition sequence will start again after a 5 minute wait.

#### ⚠ WARNING ⚠

**FAILURE TO SEAL DRAIN T-FITTINGS WITH CAPS WILL CAUSE A CARBON MONOXIDE HAZARD!**

H21.0.1

1. Shut off the electrical power to the unit and set the room thermostat to its lowest setting.
2. Turn the thermostat to **HEAT** mode.
3. Remove the burner compartment access door.

#### ⚠ IMPORTANT ⚠

**ENSURE THAT THE MANUAL GAS VALVE SWITCH HAS BEEN IN THE “OFF” POSITION FOR AT LEAST 5 MIN. DO NOT ATTEMPT TO MANUALLY LIGHT THE MAIN BURNERS.**

4. Turn the gas valve switch to the “**ON**” position.
5. Replace the burner compartment access door.
6. Turn on furnace appliance shut off valve.
7. Restore electrical power to the furnace.
8. Set the room thermostat to a point above room temperature to light the furnace.
9. After the burners are lit, set the room thermostat to the desired temperature.



## 5.2 FURNACE SHUTDOWN

1. Set the room thermostat to below set point.
2. Remove the burner compartment access door.
3. Turn the gas valve switch to the "OFF" position.
4. The furnace appliance shut-off valve may be closed if desired.
5. Power to the furnace must remain ON for the air conditioner to work.

### ⚠ IMPORTANT ⚠

IF YOU INTEND TO BE AWAY FROM HOME FOR LENGTHY PERIODS OF TIME DURING THE NON-HEATING SEASON, IT IS ADVISABLE TO FOLLOW THE FURNACE SHUT DOWN PROCEDURE.

### ⚠ WARNING ⚠

SHOULD OVERHEATING OCCUR OR THE GAS BURNERS FAIL TO SHUT OFF, CLOSE THE MANUAL GAS VALVE FOR THE FURNACE BEFORE SHUTTING OFF THE ELECTRICAL POWER TO THE FURNACE. FAILURE TO DO SO CAN CAUSE AN EXPLOSION OR FIRE RESULTING IN PROPERTY DAMAGE, PERSONAL INJURY OR LOSS OF LIFE.

BEFORE RESTARTING THE FURNACE, CHECK ALL PLASTIC VENTS AND WIRES FOR DAMAGE.

H3.24

## 5.3 AIR CONDITIONING STARTUP

### NOTE

While operating, the AC Module will remove humidity from the air. This humidity will condense on the evaporator coil and eventually fall in the drain-pan below the coil. There is a rubber hose ("P-Trap") that takes the water collected to the building service drain. Before initial operation and/or at the beginning of each cooling season, it is important that this P-trap is primed. If the P-trap dries out, air can be drawn back up the hose knocking condensate off the coil, getting the air filter and other components wet. On how to prime the condensate trap, refer to the instructions "4.8 Condensate Drain Connection".

1. Turn the Thermostat to **COOL** mode.
2. Set the room thermostat to below the current temperature to turn on AC.
3. Wait for the fan and compressor to turn on and run the unit for at least 10 minutes.
4. Power to the air conditioner must remain on for the furnace to work.

### ⚠ WARNING ⚠

AIR CONDITIONER MUST NOT BE OPERATED WHEN OUTDOOR TEMPERATURE IS BELOW 55°F.

## 5.4 AIR FLOW

For proper furnace operation, air flow over the heat exchanger is of utmost importance. Insufficient airflow accelerates metal fatigue and possible failure in the heat exchanger, as well as decrease efficiency. Excessive airflow promotes accelerated corrosion of the heat exchanger.

**IMPORTANT:**  
**DO NOT BYPASS THIS STEP OF THE START UP PROCEDURES.**

H22.0

### 5.4.1 Temperature Rise Check

**When the duct system is complete and the air filter or filters are in place, determine if the airflow is correct.**

1. Insert a duct thermometer in the supply air duct. The thermometer should be placed as close as practical to the furnace, but out of the “line of sight” of the heat exchanger (this prevents false readings owing to radiant heat). Ensure that the thermometer location is within the duct air stream. Avoid locations such as the inside radius of an elbow, etc.
2. Insert a duct thermometer in the return air duct as close to the furnace as practical. Ensure that the thermometer location will be unaffected by humidifier bypass ducts, etc. Choose a location well within the main air stream.
3. Operate the furnace long enough to obtain steady state conditions at the input listed on the furnace rating plate.
4. When the two thermometers have stabilized, usually within 5-8 minutes, compare the two readings. Subtract the return air temperature from the supply air temperature. The difference is the temperature rise, also called  $\Delta T$ .
5. Compare the measured  $\Delta T$  to the temperature rise range shown on the rating plate.
6. Unless stated differently on the rating plate, the temperature rise should normally range between 35° to 65°F (20° to 36°C). When adjusting the temperature rise, the ideal temperature rise is approximately 50°F (28°C).
7. If the measured  $\Delta T$  is above the approved temperature range, there is too little air flow. It must be increased by removing restrictions in the ductwork, adding supply or return ductwork, or by selecting a higher motor speed.

\*\*\* If the measured  $\Delta T$  is too low, there is too much air flow.

**TABLE 4.**

----- CFM AT EXTERNAL STATIC PRESSURE, INCHES WATER COLUMN --													
MODEL	HEATING	SETTING	Speed Tap#	0.1	0.2	0.3	0.4	0.5	0.6	0.7	0.8	0.9	1.0
CCGM015A	15 kBTU/H	Factory	5	439	388	333	294	240	193	-	-	-	-
		High	4	569	529	494	470	415	368	346	306	273	-
CCGM030A	30 kBTU/H	Factory	4	569	529	494	470	415	368	346	306	273	-
		High	3	771	744	729	704	693	663	644	610	566	556
CCGM040A	40 kBTU/H	Factory	3	771	744	729	704	693	663	644	610	566	556
		High	2	924	908	886	868	839	804	757	696	617	-
CCGM050A	50 kBTU/H	Factory	2	924	908	886	868	839	804	757	696	617	-
		High	1	1010	971	938	906	870	824	773	713	617	-
MODEL	COOLING	SETTING											
CACM012A	1.0 TON	Factory	5	439	388	333	294	240	193	-	-	-	-
		High	4	569	529	494	470	415	368	346	306	273	-
CACM018A	1.5 TON	Factory	3	771	744	729	704	693	663	644	610	566	566
		High	2	924	908	886	868	839	804	757	696	617	-
CACM024A	2.0 TON	Factory	3	771	744	729	704	693	663	644	610	566	566
		High	2	924	908	886	868	839	804	757	696	617	-
CACM030A	2.5 TON	Factory	2	1010	971	938	906	870	824	773	713	617	-

### 5.4.2 Calculating air flow / Capacity Check

There are circumstances where it may be desirable to know the air flow delivery through the duct system, such as when estimating the amount of air flow available for air conditioning. This can be done by direct measurement with electronic or sloped manometers and velometers, or use the formula in the next column.

$$\text{CFM} = \frac{\text{Output}}{1.085 \times \Delta T}$$

where:

- CFM is airflow in cubic feet per minute;
- $\Delta T$  is the temperature rise; and
- Output is the furnace output capacity from the rating plate.

### 5.4.3 Adjustments – Cooling

No adjustments are required or should be attempted regarding any of the components of the cooling chassis. The chassis should be checked to see that none of the wiring is loose or missing. Cooling chassis is charged with R410A refrigerant.

## 6. MAINTENANCE

### 6.1 GENERAL SAFETY RULES

1. Combustible materials should not be stored against or around the unit. Keep the unit area clear and free from all combustible materials such as newspapers, rags, cardboard, foam, plastic, paper backed fiberglass insulation, clothing, etc. This applies especially to gasoline and other flammable vapors and liquids.
2. This unit is ETL certified as a Category IV indirect or direct vent appliance. It is designed to operate as a two pipe (outdoor combustion air) system. The unit needs adequate amounts of combustion air to operate properly. Do not block or obstruct the air-intake terminal on the unit, or air openings supplying combustion air to the area where the unit is installed.
3. All doors and panels must be in place during normal unit operation. Attempting to operate the unit with missing doors or panels could lead to the creation of carbon monoxide gas.
4. If the unit is installed in a confined space or if you intend to build a unit room where insulation is present, be aware that some insulating materials are combustible. Do not allow building insulating materials to come into contact with the unit.
5. Any additions, alterations or conversions required in order for the unit to properly match the application requirements must be done by a qualified installation contractor, service agency or gas supplier, using factory specified or approved parts.
6. Familiarize yourself with the location of the gas manual shut-off valve and any electrical switch, fuse or circuit breaker associated with the unit.
7. Do not allow snow, ice or debris to accumulate around the outdoor unit exhaust and combustion air intake terminals. Blockage of the exhaust or combustion intake terminals can result in inadequate performance or nuisance shut-downs.
8. Familiarize yourself with the location of your unit filter. A blocked air filter will reduce efficiency, increase fuel consumption, raise the unit operating temperature, and shorten the life of unit components.
9. Do not cover return air grills and supply air registers with drapes, curtains, throw rugs, etc.
10. Avoid shutting off supply air registers in the interests of saving heat. While there is some validity to this practice with space heating, there is little to be gained in central heating systems. The unit requires a quantity of air passing over the heat exchanger to operate within design temperatures. Reducing the number of supply air registers available for air delivery may have the unforeseen consequence of raising the unit operating temperature, reducing unit efficiency, and shortening the life of the unit components.

#### **⚠ WARNING ⚠**

**DISCONNECT THE ELECTRICAL POWER SUPPLY TO THE FURNACE BEFORE ATTEMPTING ANY MAINTENANCE. FAILURE TO DO SO CAN CAUSE ELECTRICAL SHOCK RESULTING IN PERSONAL INJURY OR LOSS OF LIFE.**

#### **⚠ CAUTION ⚠**

**LABEL ALL WIRES PRIOR TO DISCONNECTION WHEN SERVICING CONTROLS. WIRING ERRORS CAN CAUSE IMPROPER AND DANGEROUS OPERATION.**

**ALWAYS VERIFY PROPER OPERATION AFTER SERVICING.**

H3.25

## 6.2 COOLING CHASSIS

The cooling chassis contains all items related to the cooling functions of the unit, and also contains the indoor blower and motor for the heating function. For extensive servicing, qualified personnel may choose to remove the cooling chassis from the unit and take it to a work area. Spare chassis are recommended so that extensive servicing can be performed outside the living space. This will prevent introducing dirt or doing damage in the living area, and could help to eliminate significant disruption of the air conditioning and heating functions in the living areas.

The indoor blower motor and the outdoor fan motor have permanently lubricated bearings and do not require routine service. The refrigeration system is sealed and factory charged with Refrigerant R-410A so that routine maintenance is not required. Cleaning of the outdoor coil, indoor coil, drain pan, and inside the bottom of the chassis are recommended at least once a year, and more often if the equipment is operated in a dusty or hostile environment. The electrical controls do not require routine service.

Power to the unit should always be turned OFF before performing service or removing the cooling or furnace module from the unit. One power connector and one control circuit connector are provided for easy disconnecting and re-connecting of the wires between the cooling chassis and cabinet. The front furnace panel door must be removed to allow access to the wiring harnesses. After reinstalling the cooling chassis, both panel doors must be reinstalled. Refer to: *Air Conditioner Module Removal* section of this manual.

## 6.3 AIR FILTER

All indoor return air must be filtered. A permanent-type filter is pre-installed with the unit. It is located on the air conditioning module. The provided air filter is a natural fiber washable and should be inspected frequently and cleaned or replaced as necessary.

### ⚠ CAUTION ⚠

DO NOT OPERATE YOUR HEATING MODULE OR AIR CONDITIONER FOR EXTENDED PERIODS OF TIME WITHOUT AN AIR FILTER.

A portion of the dust entrained in the air may temporarily lodge in the air duct runs and the supply registers. Any recirculated dust particles will be heated and charred by coming into contact with the heat exchanger. This residue will soil ceilings, walls, drapes, carpets, furniture, and other household articles.

### ⚠ WARNING ⚠

**DISCONNECT THE ELECTRICAL POWER SUPPLY TO THE UNIT BEFORE ATTEMPTING ANY MAINTENANCE. FAILURE TO DO SO CAN CAUSE ELECTRICAL SHOCK RESULTING IN PERSONAL INJURY OR LOSS OF LIFE.**

### ⚠ CAUTION ⚠

BE SURE THAT THE FILTER IS RE-INSTALLED WITH THE AIRFLOW DIRECTION IDENTICAL TO ITS PREVIOUS USE. REVERSING THE FILTER WILL CAUSE DUST TRAPPED WITHIN THE FILTER TO BREAK FREE AND RECIRCULATE WITHIN THE DUCT SYSTEM. CONSULT YOUR INSTALLATION CONTRACTOR OR SERVICE TECHNICIAN IF YOU HAVE ANY QUESTIONS ON INSTRUCTIONS FOR REMOVING/REINSTALLING THE AIR FILTER.

H27.1\_AC

## 6.4 LUBRICATION

Both the exhauster motor and circulating fan motor are sealed bearing type motors. No lubrication required.

### ⚠ IMPORTANT ⚠

**THE MOTOR BEARINGS WERE PRE-LUBRICATED BY THE MOTOR MANUFACTURER. DO NOT ATTEMPT TO LUBRICATE THEM. EXCESS LUBRICATION WILL VOID THE WARRANTY, SHORTEN THE SERVICE LIFE OF THE MOTORS, AND WILL ATTRACT THE BUILDUP OF DUST AND DIRT.**

## 6.5 GAS METER

Most natural gas systems and all LP gas systems have a service regulator located near the point where the gas piping enters the building.

The propane tank will normally have an additional first stage regulator located at the tank outlet valve. All of these regulators (located outdoors) will have a vent. (Figure 2)

It is important for these vents to remain clear. Do not allow moisture, which could freeze, to build up in the vent. If you see moisture building up in the regulator vent, contact your gas supplier.

H25.0.2

FIG. 2 - GAS REGULATOR VENT

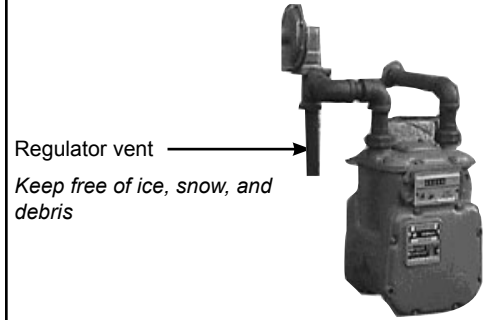

### ⚠ WARNING ⚠

**OBSTRUCTION OF THE AIR VENT ON AN LP (PROPANE) CYLINDER OR TANK REGULATOR CAN CAUSE EXPLOSION OR FIRE RESULTING IN PROPERTY DAMAGE, SEVERE PERSONAL INJURY OR DEATH.**

**YOUR GAS SUPPLIER SHOULD PERIODICALLY INSPECT AND CLEAN THE AIR VENT SCREEN TO PREVENT ANY OBSTRUCTION. KEEP PROTECTIVE REGULATOR COVER IN PLACE, AS EXPOSURE TO THE ELEMENTS CAN CAUSE ICE BUILDUP AND REGULATOR FAILURE.**

H3.29\_AC GSI

## 6.6 ROUTINE MAINTENANCE

### QUARTERLY:

- We recommend a monthly filter inspection at first, then every three months afterwards.

### YEARLY:

- Priming Trap needs to be inspected at every starting season. Add more water if necessary.
- Check that barbed fitting caps are tight and condensate lines remain clean and secured by hose clamps.

### ⚠ IMPORTANT ⚠

**WE RECOMMEND THAT YOUR UNIT AND EXHAUST/COMBUSTION AIR VENTS BE CHECKED BY A QUALIFIED SERVICE TECHNICIAN ONCE A YEAR.**

It is good practice to give a quick inspection of your unit each time you inspect or clean the air filter.

### Things to check:

- Check the unit for obvious signs of deterioration.
- Check the venting and combustion air piping to ensure that it is still fastened to the unit. It should not sag, and should have a 1/4" (6mm) per foot (305mm) slope upwards, to the outside wall or termination.
- There should be no water marks on the floor under the venting. Water marks may indicate a leaking pipe joint.
- All ductwork should be secured to the unit, and all ductwork should be solidly supported throughout.
- Water should flow easily through the condensate drain lines. You may be able to observe this while the unit is operating if your condensate drain line from the drain trap assembly terminates at a floor drain. If the drain lines are opaque, your service technician will check them during the annual servicing.
- The gas burner should be observed from time to time during the heating season to ensure that the flames are clean and blue. A bit of orange color in the flame is not likely to be a problem and is probably dust particles burning. If you observe lazy yellow flames, call your heating or service contractor immediately. The yellow flames inevitably lead to soot-ups.
- The combustion air and exhaust terminals should be inspected occasionally to ensure that they are free of obstructions and debris.

H27.3.1\_AC



# 7. TROUBLESHOOTING

## 7.1 FURNACE TROUBLESHOOTING CHART

TABLE 6.

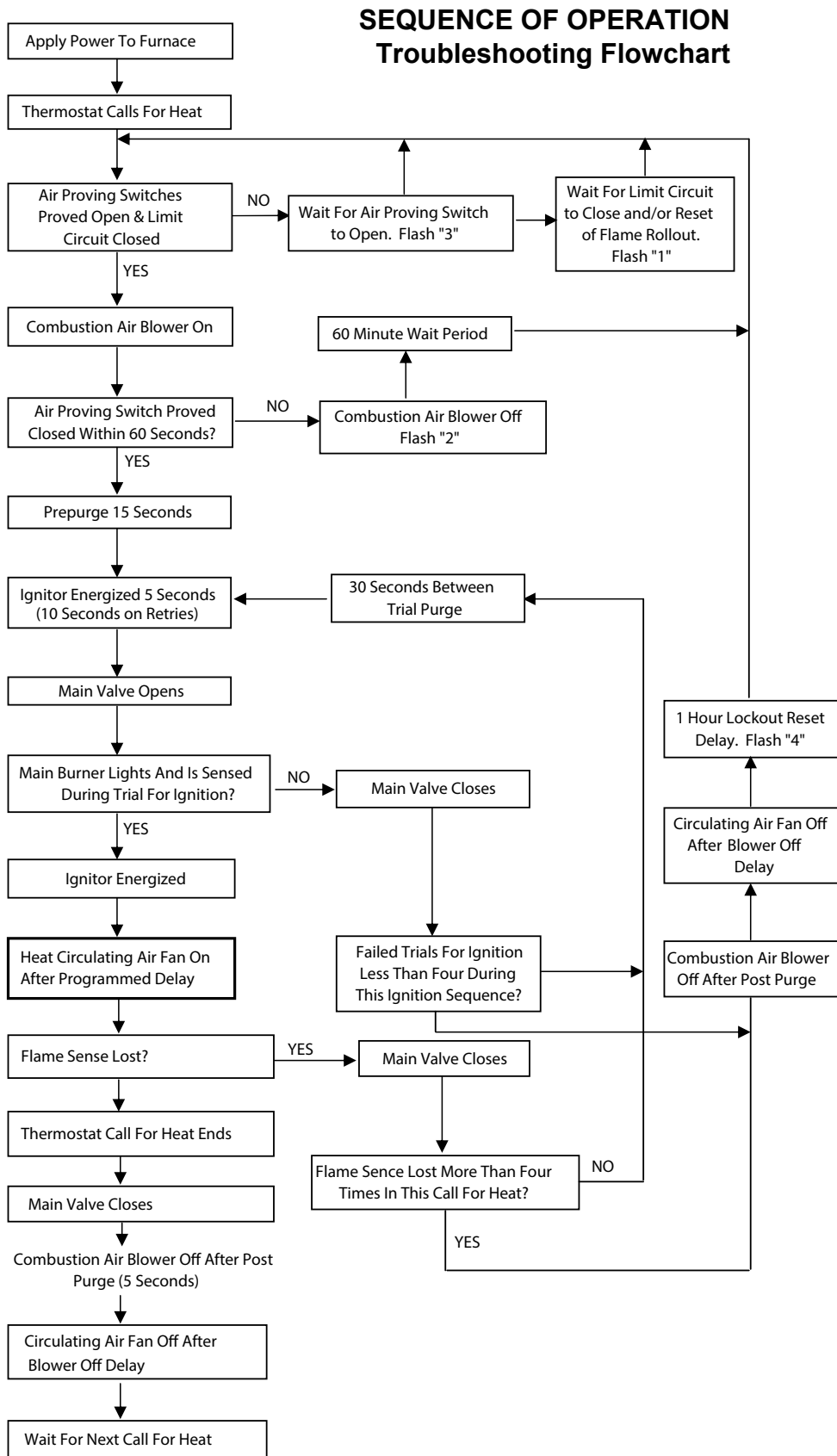

## 7.2 AIR CONDITIONING TROUBLESHOOTING

TABLE 7.

<b>WARNING!</b>		
<b>THIS TROUBLESHOOTING GUIDE IS INTENDED FOR USE BY QUALIFIED SERVICE PERSONNEL ONLY!</b>		
<b>FAULT CONDITION</b>	<b>POSSIBLE CAUSE</b>	<b>CORRECTION</b>
<b>Unit will not operate</b>	Power disconnected or loose connection	Check voltage at contactor in condensing unit
	Blown fuse / breaker tripped	Replace fuses / reset breaker
	Thermostat out of calibration is set too high	Reset
	Contactor defective	Check for 24VAC at contactor coil, replace if open
	Transformer defective	Check wiring – replace transformer
<b>Outdoor fan on; Compressor off</b>	High pressure control open (if provided)	Reset – see high pressure correction (high pressure control opens at 600 psig)
	Run or start capacitor defective	Replace
	Start relay defective	Replace
	Loose wire	Check for correct voltage at compressor – check and tighten all connections
<b>Too little cooling</b>	Compressor stuck, grounded or open motor winding, open internal overload	Wait at least 2 hours for overload to reset; if still open, replace the compressor
	Low voltage condition	Add start kit components
	Improperly sized unit	Recalculate load
	Improper indoor airflow	Check-should be approximately 400 CFM per ton
	Incorrect refrigerant charge	Charge per procedure in installation manual
<b>Compressor operates in short cycles</b>	Air, non-condensables or moisture in system	Recover refrigerant
	Incorrect voltage	At compressor terminals, voltage must be +/-10% of nameplate marking when unit is operating
	Defective overload protector	Replace – check for correct voltage
<b>High head pressure; Low suction pressure</b>	Refrigerant undercharge	Add refrigerant
	Restriction in liquid line, expansion device or filter drier	Remove or replace defective component
<b>High head pressure; Normal suction pressure</b>	Lack of sufficient indoor airflow	Clean/check filters, registers, or evaporator coil that may cause a restriction.
	Dirty outdoor coil	Clean coil
	Refrigerant overcharge	Correct system charge
	Outdoor fan not running	Repair or replace
	Air or non-condensables in system	Recover refrigerant, evacuate and recharge

<b>WARNING!</b>		
<b>THIS TROUBLESHOOTING GUIDE IS INTENDED FOR USE BY QUALIFIED SERVICE PERSONNEL ONLY!</b>		
<b>FAULT CONDITION</b>	<b>POSSIBLE CAUSE</b>	<b>CORRECTION</b>
<b>Low head pressure;</b> <b>High suction pressure</b>	Expansion device stuck in open position	Replace expansion device
	Defective compressor valves	Replace compressor
<b>Low suction pressure;</b> <b>Compressor cool;</b> <b>Ice on indoor coil</b>	Low indoor airflow	Increase speed of blower or reduce restriction – replace air filter
	Operating below 65degF outdoors	Add low ambient kit
	Moisture in system	Recover refrigerant – evacuate and recharge – replace filter drier
<b>High suction pressure;</b> <b>or fluctuating head and suction pressures</b>	Excessive load	Recheck load calculation
	Defective compressor	Replace
	TXV hunting	Check TXV bulb clamp – check air distribution on coil – replace TXV
	Air or non-condensibles in system	Recover refrigerant, evacuate and recharge
<b>Pulsing noise at expansion device or liquid line</b>	Air or non-condensibles in system	Recover refrigerant, evacuate and recharge
<b>Registers sweat</b>	Low indoor airflow	Increase speed of blower or reduce restriction –

### 7.3 ADJUSTING SYSTEM CHARGE

Units come from the factory charged with the correct amount of refrigerant. There are times, however, when the charge may need to be adjusted. Refrigerant leaks and addition of system components for servicing or monitoring, for example, will require that the refrigerant charge be adjusted for the unit to function as intended. Note that only qualified HVAC technicians shall adjust the charge.

#### **Procedure:**

1. Operate the unit at standard AHRI conditions as close as possible (80°F DB / 67°F WB Indoor, 95°F DB Outdoor).
2. Connect charging hose from liquid port on the refrigerant bottle to charging service port.
3. Open refrigerant bottle and purge hose at bottle fitting.
4. Temporarily install a temperature measuring device on the liquid line near the TXV and one at the suction line near the compressor. Ensure that the temperature measuring device makes adequate contact and insulated for accurate readings.
5. Operate the system for at least 10 minutes.
6. Check sub-cooling and superheat. Systems using thermostatic expansion valves should have a sub-cooling as per its nameplate, if explicitly stated, or 7.5°F +/- 1°F otherwise. Superheat should be 7°F to 9°F.
  - i. If sub-cooling and superheat are low, adjust the TXV to 7°F to 9°F superheat.
  - ii. If sub-cooling is low and superheat is high or normal, add charge to obtain the required sub-cooling.
  - iii. If sub-cooling and superheat are high, adjust the TXV to 7°F to 9°F superheat.
  - iv. If sub-cooling is high or normal and superheat is low, remove charge to lower the required sub-cooling.

## 7.4 DIAGNOSTIC CODES FOR STATUS LED

A 3 colour LED is provided to indicate system faults. LED codes are as follows:

- LED Off - No power to control, push button switch pressed, or control fault
- LED Steady On (any colour) - Control hardware fault detected
- Slow Green Flash - No call for heat, no active errors
- Slow Orange Flash - Call for heat present, no active errors
- Rapid flash - Incorrect 24VAC phasing/twinning errors

TABLE 8.

STATUS LED	FAULT CONDITION
Red LED indicates following codes:	
LED OFF	No power to control or control hardware fault detected
LED ON	Normal operation
1 Flash	High limit switch open
2 Flashes	Pressure switch open with inducer on
3 Flashes	Pressure switch closed with inducer off
4 Flashes	Lockout due to too many failed ignition attempts (1 hour lockout)
5 Flashes	L1/Neutral Polarity problem
6 Flashes	Too many limit trips within one call for heat
7 Flashes	Pressure switch cycle lockout
8 Flashes	Lockout due to too many flame dropouts
9 Flashes	Not used
10 Flashes	Flame present with gas valve off

H23.4.1

## 7.5 FAULT CODE HISTORY

The control stores the last 5 fault codes in memory. When the push button switch is pressed, the control will flash the stored fault codes when the switch is released. The most recent fault code is flashed first, the oldest last.

Fault history may be cleared by holding the push button switch for more than 5 seconds.

H23.5

## 8. OWNER'S SERVICE INFORMATION

TABLE 9.

HOMEOWNER'S REFERENCE TABLE	
Model No.	
Serial No. <i>(serial number located on bottom of inside door)</i>	
Date Installed	
Contractor	
Contact	
Address	
Postal Code/Zip Code	
Telephone No.	
After Hours No.	
<b>If different from Installation Contractor:</b>	
Service Tech.	
Telephone No.	
After Hours No.	
<b>Fuel Supplier:</b>	
Gas Supplier	
Contact	
Telephone No.	
After Hours No.	

# 9. WARRANTY

**Wolf Steel Ltd.** products are manufactured under the strict Standard of the world recognized ISO 9001 : 2008 Quality Assurance Certificate. **Wolf Steel Ltd.** products are designed with superior components and materials assembled by trained craftsmen who take great pride in their work. The complete appliance is thoroughly inspected by a qualified technician before packaging to ensure that you, the customer, receives the quality product that you expect from **Wolf Steel Ltd.**

## Condo Pack LIMITED WARRANTY

### LIMITED WARRANTY

This heating/cooling appliance is warranted by Wolf Steel Ltd. (Condo Pack) to be free from defects in materials and workmanship under normal use and maintenance.

The Stainless Steel Heat Exchanger (Gas Furnace version) is warranted for a period of **20 years** (Parts only, shipping and warranty labor cost are not covered. Such cost are to covered by the owner of appliance).

For the first **10 years** of the warranty period Wolf Steel Ltd. will replace the entire furnace module if the Heat Exchanger fails (the Heat Exchanger shall be defined as the stainless steel components making up the primary and secondary exchange surfaces only, the plastic front manifold cover and gasket are NOT included as part of the Heat Exchanger) and all conditions and limitations of the warranty are met.

For the **11th through 20th year** of the warranty, replacement cost of the furnace module will be prorated.

All other covered components will be warranted for a period of **5 years** during which Wolf Steel Ltd. will cover the replacement of the component (Parts only, shipping and warranty labor cost are not covered. Such cost are to covered by the owner of appliance).

Components not covered by the warranty include consumables such as filters, fuses, driers, refrigerant and oils. Cabinetry components, grills and wiring components are also excluded from the warranty.

The warranty period begins at the date of the original installation and if this date cannot be verified, the warranty period begins 6 months after the manufacture date of the appliance (indicated by the first 4 numbers of the serial number).

The warranty is only valid when:

- the appliance has not been moved from its location of original install,
- has been installed by a licensed or qualified HVAC technician,
- was installed in accordance with the manufacturer's directions in the Installation and Operation Manual, and
- was installed in compliance with all industry standards, national and local codes.

Warranty claims must be authorized by Wolf Steel Ltd. recognized representative or agent; parts/components being claimed may need to be analyzed at a Wolf Steel Ltd. facility. Records of installation date and periodic maintenance are required to process claim. All warranty service must be done by Wolf Steel Ltd. authorized service technicians using approved components.

### Limitations:

Wolf Steel Ltd. is not responsible for:

1. Damages/Repairs/Costs incurred due to faulty installation or application.
2. Damages/Repairs/Costs caused by an installation that is not performed in compliance with all federal, provincial/state laws or regulations, and the Installation and Operation Manual.
3. Damage as a result of vandalism, freight damage, floods, fires, winds, lightening, and accidents, or any act of nature. Atmospheres contaminated by compounds of chlorine, halogenated hydrocarbons, or other damaging chemicals causing deterioration of components, or other conditions beyond the control of Wolf Steel.
4. Use of components or accessories not compatible with this appliance.
5. Products installed outside of Canada and the United States and its territories.
6. Routine maintenance, but not limited to, cleaning of the coils, filter cleaning and/or replacement and lubrication.
7. Damages/Repairs/Costs incurred because of the use of Parts not supplied or previously authorized by Wolf Steel.
8. Damages or repairs required as a result of improper use, maintenance, operation, servicing, cleaning or replacing filters.
9. Failure to operate due to interruption and/or inadequate electrical service.
10. Damages, defects or failures caused by accidents or negligent or unreasonable use or operation of the unit and its' components, including without limitation, operation beyond rated capacity and operation of electrical components at voltage other than that specified on the rating plate.
11. Wolf Steel will not in any event extend warranty coverage to any incidental, consequential or indirect damages.
12. Changes in the appearance of the unit that does not affect its performance.
13. Damages, defects or failures caused by operation of the unit in abnormal environmental conditions (i.e. salt air).
14. Damages, defects or failures caused by conditioned air(return air) supplied to the furnace being greater than 20% from out of doors (13°C/55°F min. return air temperature).
15. Damages, defects or failures caused by operating air conditioning modules during periods when outdoor ambient temperatures fall below 13°C/55°F.

ALL SPECIFICATIONS AND DESIGNS ARE SUBJECT TO CHANGE WITHOUT PRIOR NOTICE DUE TO ON-GOING PRODUCT IMPROVEMENTS.  
Napoleon® IS A REGISTERED TRADEMARK OF WOLF STEEL LTD.

### FOR HOMEOWNERS FUTURE REFERENCE

Model and Serial Number \_\_\_\_\_  
*(Serial number located on inside bottom door)*  
Installation Date \_\_\_\_\_

Dealer Name \_\_\_\_\_  
Dealer's City/Province-State/Postal-Zip Code \_\_\_\_\_  
Telephone/Fax \_\_\_\_\_  
E-mail Address \_\_\_\_\_

For further information about this warranty, contact Wolf Steel Ltd. *Technical Service Department* by • phone (888) 721-8324 • by email: hvacsupport@napoleonproducts.com • or mail to **WOLF STEEL<sup>LTD</sup>**, 24 Napoleon Road, Barrie, Ontario L4M 0G8 Canada



www.napoleonheatingandcooling.com







Other Napoleon Products



Fireplace Inserts • Charcoal Grills • Gas Fireplaces • Waterfalls • Wood Stoves  
Heating & Cooling • Electric Fireplaces • Outdoor Fireplaces • Gas Grills



24 Napoleon Road, Barrie, Ontario, Canada L4M 0G8  
214 Bayview Drive, Barrie, Ontario, Canada L4N 4Y8  
103 Miller Drive, Crittenden, Kentucky, USA 41030  
7200 Trans Canada Highway, Montreal, Quebec, Canada H4T 1A3

Fireplaces / Heating & Cooling call: 705-721-1212 • Grills call: 705-726-4278  
napoleonproducts.com

W415-1307 / A / 02.05.2016

