

This Owner's Manual is provided and hosted by [Appliance Factory Parts](#).



# GENERAL DS50LC Owner's Manual

[Shop genuine replacement parts for GENERAL DS50LC](#)



Appliance Factory Parts  
© http://www.appliancefactoryparts.com

[Find Your GENERAL Humidifier Parts - Select From 70 Models](#)

----- Manual continues below -----

# DS 50 / DS 50 LC

Elite Steam Residential Humidifiers



## User manual

Revision 1.2



# Warning

If present, remove the following items:

REMOVE BEFORE INSTALLING

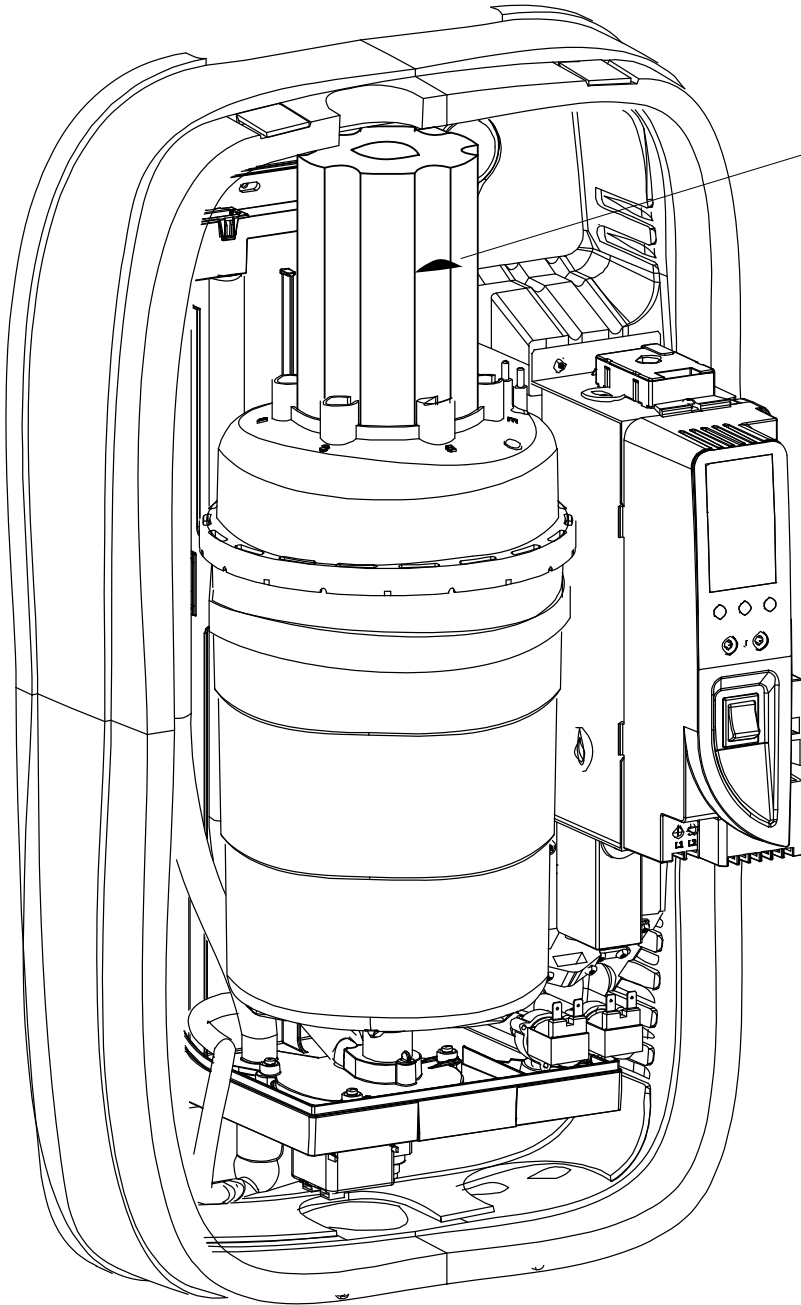

# IMPORTANT WARNINGS

We wish to save you time and money!  
We can assure you that the thorough reading of this manual will guarantee correct installation and safe use of the product described.



**BEFORE INSTALLING OR HANDLING THE HUMIDIFIER PLEASE CAREFULLY READ AND FOLLOW THE INSTRUCTIONS AND SAFETY STANDARDS DESCRIBED IN THIS MANUAL AND ON THE LABELS ATTACHED TO THE DS 50 / DS 50 LC.** THIS HUMIDIFIER MUST BE INSTALLED BY A QUALIFIED HVAC, PLUMBING, OR ELECTRICAL CONTRACTOR. ALL WARRANTIES ARE VOID IF INSTALLED BY A NON-TECHNICIAN.

**CAUTION: ALWAYS DISCONNECT THE MAIN POWER BEFORE OPENING OR SERVICING THE HUMIDIFIER!**

*The Elite Steam* produces non-pressurized steam by means of electrodes immersed in the water contained in the plastic steam generator cylinder. Electric current passes through the water between the electrodes, heating the water into steam, which is then used to humidify the air.

The quality of the water used affects the operation of this unit, so the Elite Steam may be supplied with untreated water, as long as this is drinkable and not softened or demineralized. The water converted into steam is automatically replaced through an electric fill valve. Periodically, based on the water quality, the unit will also drain some water to dilute the build-up of minerals in the steam generator. In cases of high water mineral content, an activated carbon filter in series with a particulate filter, no more than 5 microns is suggested.

This humidifier has been designed exclusively to directly humidify rooms or ducts, using a distribution system. The installation, use and maintenance operations must be carried out according to the instructions contained in this manual and on the labels applied internally and externally.

**IMPORTANT: BEFORE beginning installation:**

- Check for shipping damage to cartons. Mark the shipping waybill accordingly.
- Open cartons and check for any hidden damage. Mark the shipping waybill accordingly.
- Check packing slip to ensure all items have been received. Notify GENERAL FILTERS, INC. of any shortages or damaged parts. **You must notify General Filters, Inc. within 5 working days of any shortages.**

**CAUTION: ELECTRIC SHOCK HAZARD! The humidifier has components under power inside!**

**CAUTION: SCALDING HAZARD! The humidifier has hot parts (100°C/ 212°F)**

**WARNING: Install the humidifier out of the reach of children.**

**The humidifier must be installed in accordance with all local and national standards.**

**All service and/or maintenance operations must be performed by qualified personnel who are aware of the necessary precautions and are capable of performing the operations correctly.**

**Disconnect the humidifier from the main power supply before accessing any internal parts.**

**The conditions of the environment and the power supply voltage must comply with the specified values listed on the data label in the humidifier.**

**All other uses and modifications made to the humidifier that are not authorized by the manufacturer are considered incorrect, and the manufacturer assumes no liability for the consequences of any such unauthorized use.**

**Please note that the humidifier contains powered electrical devices and hot surfaces.**

**WARNING: Your humidifier requires water to operate. Do NOT mount it above materials or machinery that could be damaged if a leak occurs. General Filters, Inc. assumes no responsibility for consequential or inconsequential damage as a result of any leaks.**

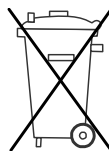

**Disposal of the parts of the humidifier: the humidifier is made up of metallic and plastic parts. All parts must be disposed of according to the local standards on waste disposal.**



# CONTENTS

<b>1.</b>	<b>HOW THE ELITE STEAM WORKS</b>	<b>6</b>
1.1	BASIC OPERATION	6
1.2	CYLINDER LIFE	7
1.3	CALCULATING HUMIDITY LOAD	7
<b>2.</b>	<b>MODELS</b>	<b>8</b>
<b>3.</b>	<b>INSTALLATION</b>	<b>9</b>
3.1	POSITIONING	9
3.2	MOUNTING	9
3.3	PLUMBING	11
3.4	STEAM DISTRIBUTION	12
3.5	POWER WIRING	15
3.6	CONTROL WIRING	15
3.7	WIRING CONNECTIONS:	17
<b>4.</b>	<b>START-UP</b>	<b>18</b>
4.1	STARTUP CHECKLIST	18
4.2	THE ELITE STEAM CONTROLLER	18
4.3	STARTING THE ELITE STEAM	18
4.4	STARTING WITH A NEW CYLINDER	18
<b>5.</b>	<b>OPERATING THE ELITE STEAM</b>	<b>19</b>
5.1	DISPLAYING INFORMATION	19
5.2	CHANGING THE MAXIMUM PRODUCTION	19
5.3	ACTIVATING MANUAL DRAIN	19
5.4	RESETTING THE HOUR COUNTER	19
5.5	HUMIDISTATS	20
5.6	ALARMS	20
<b>6.</b>	<b>TROUBLE SHOOTING</b>	<b>21</b>
<b>7.</b>	<b>MAINTENANCE</b>	<b>22</b>
7.1	PERIODIC CHECKS	22
7.2	CYLINDER MAINTENANCE	22
7.3	REPLACEMENT PARTS	23
<b>8.</b>	<b>TECHNICAL SPECIFICATIONS</b>	<b>24</b>
<b>9.</b>	<b>LIMITED WARRANTY</b>	<b>25</b>

# 1. HOW THE ELITE STEAM WORKS

## 1.1 Basic Operation

The Elite Steam is an electrode humidifier. It produces steam for humidification by passing electric current through the water between metal electrodes in the plastic steam generator cylinder. There are no heating elements. Steam output is directly proportional to the conductivity of the water, and the amount of electrode immersed in the water.

On a call for humidity, the **Elite Steam** controller will open the water fill valve (1) and allow water to enter the cylinder. A flow restrictor (4) prevents the unit from filling too quickly or with too much pressure. The water flows up the fill tube (2) and into the fill cup (3). Water then flows over the dam in the fill cup (3), which creates a 1" air gap to prevent backflow of contaminated water into the feed lines, and through the fill tube (6) and into the bottom of the steam cylinder (5). Any backflow or overflow of water travels through the overflow hose (13) to the drain.

As the water fills the cylinder, it will reach the electrodes (7) and current will begin to flow. As the water continues to fill the cylinder, the current will increase, and this is monitored by an amperage transformer connected to one of the power wires and located on the electronic controller. When the desired current is reached, the fill valve will close (1) and the water will then begin to warm and produce steam. If the water reaches the cylinder full probes (9) or if current rises too much, the drain pump (11) will be activated to drain away some water and reduce the current flow to acceptable levels. Note that, any time the drain pump is activated, the tempering valve (10) will be opened for tempering the hot drained water down to 140 degrees F / 60 degrees C in accordance to local and national standards.

Periodically, based on the incoming water conductivity, the unit will run drain pump (11) and drain some water to reduce the mineral concentration. Every 120 hours the unit automatically drains to remove mineral sediment on the bottom of the cylinder. A strainer (12) in the cylinder helps to prevent mineral debris from jamming the drain pump (11). In case DS 50 / DS 50 LC remains powered but idle, i.e. without producing steam, for more than 72 hours (3 days), the cylinder will be emptied to not have stagnant water inside.

If there is no water in the cylinder, there will be no current flow and no steam production. The electrodes do not burn out, but they will eventually become completely coated with mineral and the cylinder will then need to be replaced. Cleaning cylinders may cause electrode damage, therefore voiding its warranty. See 7.2.2 maintenance section on page 21.

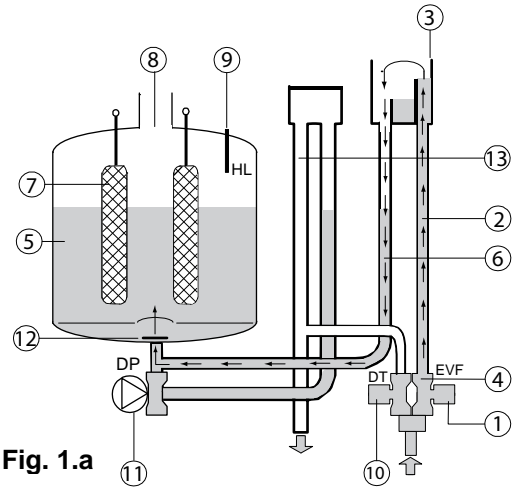

Fig. 1.a

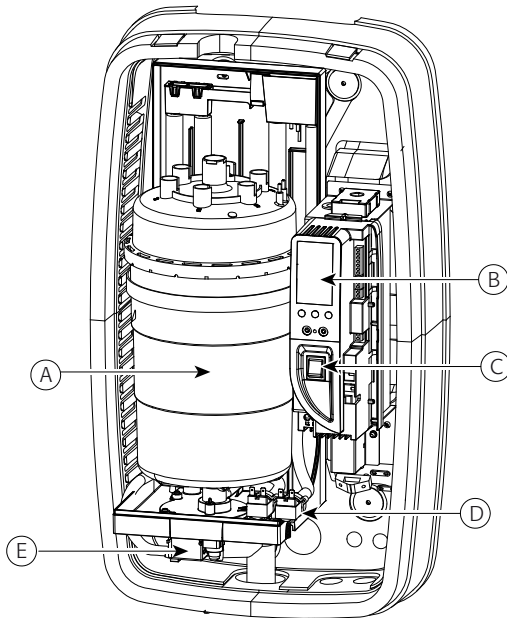

Fig. 1.b

No.	Description
A	Steam generator cylinder
B	User interface/display
C	On/Off, SET buttons
D	Fill & tempering valves
E	Drain pump

Tab. 1.a

## 1.2 Cylinder Life

### 1.2.1 Basics of the Steam Cylinder

The Steam Cylinder is the engine of the humidifier. As the humidifier operates water is evaporated and minerals are left behind. Much of these minerals are removed through the cylinder drain. Some are deposited on the walls of the cylinder and the cylinder electrodes. When a lower section of the electrodes develop a thick coating, the water level is raised to expose clean electrode surface. Eventually minerals cover the electrodes' entire length with a thick coating and little electrical current can pass between them resulting in poor steam output. The humidifier can sense the low amperage and will display the E6 Cylinder Exhausted error code. There are several factors that influence cylinder life.

### 1.2.2 Water

Characteristics of water influence cylinder life and can vary greatly from place to place. Total mineral content of the water is important. Equally important is what minerals are present in the water. Most water conditions result in flaky scale that eventually fills the bottom of the cylinder until it can no longer function. Water with high silica content can result in a thin glass-like coating on the electrodes that is highly insulating resulting in shorter cylinder life. **Only cold non-softened tap water is to be used. Water conductivity that is not matched to the correct cylinder will shorten cylinder life.**

### 1.2.3 Water Filtration

Typically additional filtration of the incoming water supply is not necessary. If, however, mineral content is known to reduce cylinder life excessively or if cylinder life proves insufficient then water filtration can be added. In most cases the addition of a two element water filter can improve cylinder life. The filter should contain an activated carbon element and a particulate filter element rated for 5 microns or less. Micron is a size measurement. The filter system should have a flow rate of at least 2 gpm. The activated carbon will absorb much of the mineral content while the particulate filter will catch any granular material or sediment. It is important to remember that the increase in cylinder life will be accompanied by the need to replace filter elements with each cylinder change.

### 1.2.4 Humidity Load and Cylinder Life

Humidity load demands have an effect on cylinder life. Normal installations where humidity capacity is properly sized require only intermittent periods where full humidifier capacity is required. This allows the water level in the cylinder to be increased only as electrode segments become insulated. This tends to maximize cylinder life.

**Extraordinary installations that require constant operation at full capacity reduce cylinder life.** The water level in the cylinder is, on average, much higher, and the electrodes become completely insulated more quickly. Installations like this may result in cylinder life of less than 1000 hours.

**The importance of providing adequate humidifier capacity should not be underestimated.**

### 1.2.5 Maximum Production

Another factor affecting cylinder life is the maximum production setting. A higher production rate will result in a shorter cylinder life. For this reason DS50 or DS50LC units are preset from the factory at 70%. Further reductions in Maximum Production will extend cylinder life. See Figure 1.c.

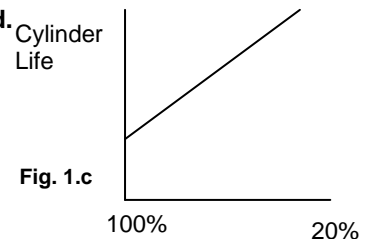

### 1.2.6 Structures Under Construction

In high end construction projects, humidification is often required while the structure is being finished. Humidification is necessary to protect and stabilize wood floors, trim and decoration. Humidification load, however, in an unfinished structure may be five to eight times higher than when finished. Elite Steam humidifiers may be operated while construction is underway but, reduced cylinder life is to be expected and budgeted for. **Good practice dictates that the steam cylinders also be replaced once the project is complete.**

## 1.3 Calculating Humidity Load

### 1.3.1 Steps to Determine Humidity Load

Total Square Footage  
 x Average Ceiling Height  
 x Factor From Table 1.2  
x 1.05 for each Fireplace  
 Humidity Load in lbs./hour  
  
x 2.88 convert to gallons/day  
 Gallons per Day Humidity Load

Table 1.2 Pounds of Moisture / Hour / Cubic Foot \*

Indoor Air Temp °F	Indoor RH%			
	35%	40%	45%	50%
68	0.00015	0.00018	0.00021	0.00024
70	0.00017	0.00020	0.00023	0.00026
72	0.00019	0.00022	0.00025	0.00028

\* Based on .5 air changes per hour.

\*Based on .5 air changes per hour.

## 2. MODELS

There are two basic models available for different water conditions.

Duct Steam Injection



**Fig. 2.a**

### MODEL LIST

PART NUMBER	DESCRIPTION	PARTS INCLUDED
DS 50	Duct steam injections 58 gallons per day (20 Lbs per hour) 220-240V	Humidifier with Duct Mount Kit and Humidity GFX50 control.
DS 50 LC	Duct steam injections 58 gallons per day (20 Lbs per hour) 220-240V	Humidifier for Low Conductivity water. Includes Duct Mount Kit and GFX50 control.

## 3. INSTALLATION

### 3.1 Positioning

The **Elite Steam** has been designed for wall mounting and, since it is an atmospheric steam humidifier, should be placed close to the point where the steam will be used, to minimize the steam hose length (and the amount of condensate). Do not mount on furnace, air handler or ductwork. **Certain clearances must be maintained around the unit for safety and maintenance.**

### 3.2 Mounting

#### 3.2.1 Removing the front cover

The front cover is secured by two screws located in the bottom side of the unit. Use a phillips screwdriver to remove the screws. The front is clasped with 2 clips on the top of the back part. To remove the front cover, hold by the sides pivot the bottom out and lift cover. When installing the cover, be careful not to over-tighten the screws.

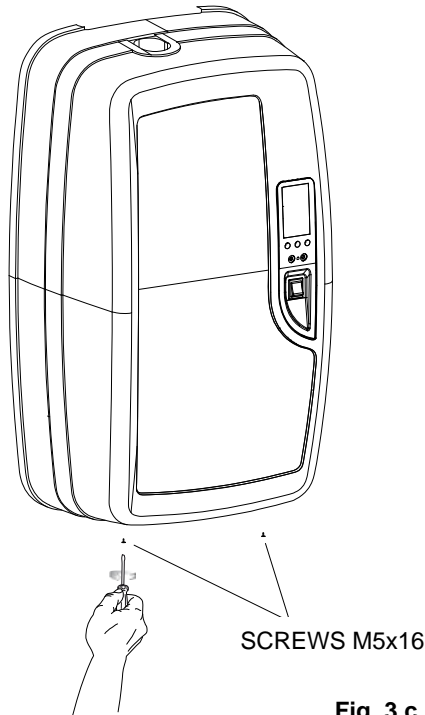

Fig. 3.c

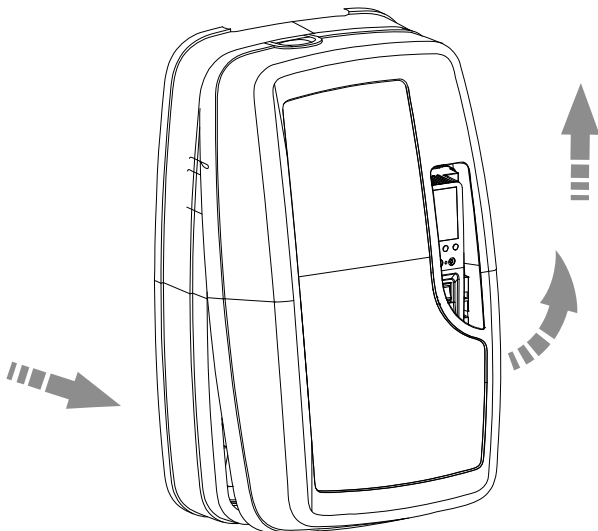

Fig. 3.d

#### Clearance Dimensions

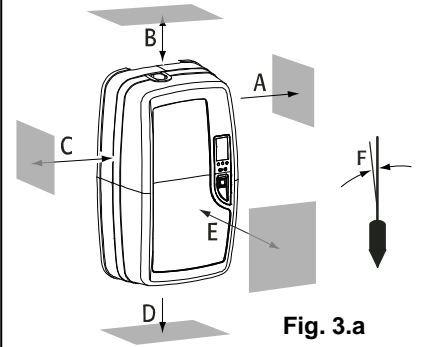

Fig. 3.a

	Millimeters	Inch
A	(150 mm)	6"
B	(150 mm)	6"
C	(150mm)	6"
D	(150 mm)	6"
E	(600 mm)	24"
F	max. 0.2°	

Tab. 3.a

#### Unit Dimensions: Duct Units

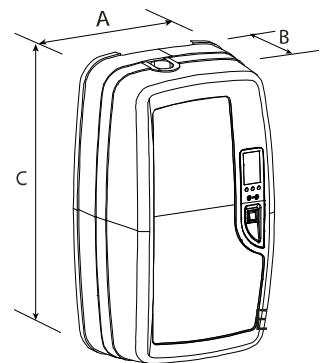

Fig. 3.b

	Millimeters	Inch
A	445 mm	17.5"
B	290 mm	12"
C	790 mm	32"
	Kilograms	Pounds
Weight empty	11kg	24 lbs
Weight packaged	13kg	29 lbs
Weight installed with water	23kg	51 lbs

Tab. 3.c



### 3.3 Plumbing

#### 3.3.1 Water Characteristic Requirements

The humidifier must be supplied with water with the following characteristics:

- pressure between 20psi and 110psi or 0.1 and 0.8 MPa (1 and 8 bar)
- temperature between 33°F and 104°F or 1°C and 40°C
- flow-rate minimum of 0.83 L/min or 0.22gpm
- hardness no greater than 40°FH (equal to 400 ppm<sup>3</sup> of CaCO), conductivity: from 125 to 1250 μS/cm
- absence of organic compounds
- the characteristics of the water of supply must fall within the following limits:

LIMIT VALUES FOR LOW SALT CONTENT WATER

	Units	Min	Max
Hydrogen ions (pH)		7	8.5
Specific conductivity (R,20°C)	μS/cm	300	
Total dissolved solids (c R)	mg/l	(*)	(*)
Dry residue at 180°C	mg/l	(*)	(*)
Total hardness	mg/l CaC <sub>2</sub> O	150	400
Temporary hardness	mg/l CaC <sub>2</sub> O	=	200
Iron + Manganese	mg/l Fe + Mn	=	0.2
Chlorides	ppm Cl	=	30
Chlorides	mg/Si <sub>2</sub> O	=	20
Chlorine residue	mg/l Cl-	=	0.2
Calcium sulphate	mg/l CaS <sub>4</sub> O	=	100

Tab.3.d

LIMIT VALUES FOR LOW NORMAL WATER

	Units	Min	Max
Hydrogen ions (pH)		7	8.5
Specific conductivity (R,20°C)	μS/cm	125	500
Total dissolved solids (c R)	mg/l	(*)	(*)
Dry residue at 180°C	mg/l	(*)	(*)
Total hardness	mg/l CaC <sub>2</sub> O	0	200
Temporary hardness	mg/l CaC <sub>2</sub> O	=	150
Iron + Manganese	mg/l Fe + Mn	=	0.2
Chlorides	ppm Cl	=	20
Chlorides	mg/Si <sub>2</sub> O	=	20
Chlorine residue	mg/l Cl-	=	0.2
Calcium sulphate	mg/l CaS <sub>4</sub> O	=	60

Tab.3.e

(\*) Values dependent on the specific conductivity: in general:  $cR \sim 0.65 \cdot \sigma R$ , 20°C;  $R180 \sim 0.9 \cdot \sigma R$ , 20°C

Note: There is no relationship between the hardness and conductivity of water.

**Water Conductivity must be matched by specifications of the steam cylinder.** Check or know the water conductivity of the proposed site before installation. Replace the steam cylinder before startup if not correct. See Table 3.f right.

DS 50 / DS 50 LC models	Conductivity μS/cm	Steam Cylinder
DS50	300-1250	50-14
DS50LC	125-500	50-15

Tab.3.f

#### The following water types are not acceptable:

1. Softened water as this will lead to foam, electrode corrosion and greatly shortened cylinder life.
2. Water containing disinfectants or corrosion inhibitors, as these are potential irritants.
3. Industrial water, boiler water or water from cooling circuits.
4. Any potentially chemically or bacteriologically contaminated water.
5. Heated water.

#### 3.3.2 Water Supply Connection

We recommend the connection between the fill valve and the water supply line by a soft poly hose capable of absorbing the water hammering in order to avoid damage to the fill valve itself. The water line may be routed through the back or through the bottom of the unit. With poly tubing, a tubing support must be used to prevent tubing collapse and leaks. The fitting then threads onto the fill valve inlet located on the bottom of the humidifier using a 3/4" G connection. **Note that there is a strainer built into the fill valve fitting underneath the unit, which will require periodic cleaning, so be sure to allow clearance for access. Length of 1/4" tube should be kept to less than 1M or 3 ft.**

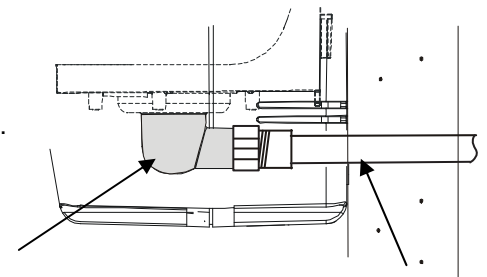

Water drain outlet

Fig. 3.g

Extension tube

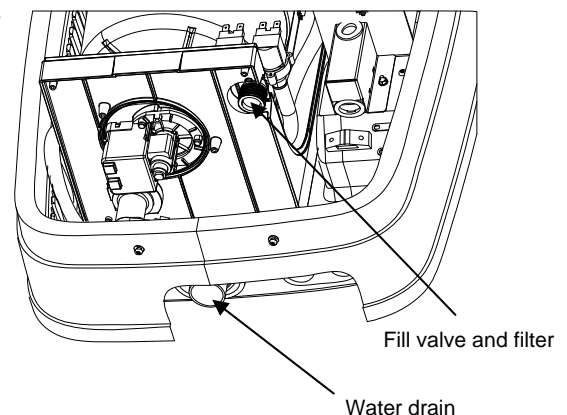

Fig. 3.h

### 3.3.3 Water Drain

The DS50 and DS50 LC requires a connection to a drain. The drain line may be routed out the back or bottom of the unit using the included angle fitting. The drain line can be 1-1/4" PVC, CPVC or polypropylene. The drain line is not glued or otherwise attached to the humidifier so it must be supported by itself. A coupling should be used. The DS 50 / DS 50 LC includes a drain tempering valve that runs whenever the drain pump runs and flushes cool water into the drain line to insure the drain water temperature never exceeds 60°C or 140°F.

The drain water characteristics are:

- Drain Rate 26.8 liter per minute or 7.1 gallons per minute
- Connection 32mm or 1 1/4"
- Temperature 60°C or 140°F

NOTE: Drain line must be trapped under the unit to prevent flash steam from condensing in the unit cabinet.

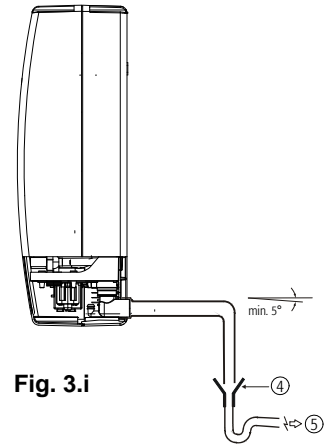

### 3.3.4 Drain Connections

When using a rear outlet drain passing through drywall, we suggest using a 1 1/4" extension tube type SJ (see Fig. 3.i). When using a bottom outlet drain, attach the included 90° fitting to the drain outlet. The drain outlet may be rotated. Then connect a 1 1/4" trap adaptor to connect to drain pipe.

**IMPORTANT WARNING: The drain pipe must be free without back pressure. We recommend an external anti-flooding device not supplied to protect from faults of external hydraulic circuits.**

## 3.4 Steam distribution

### 3.4.1 Duct steam injection

The maximum allowed duct static pressure is 2 in WC.

The **DS 50 / DS 50 LC** duct injection models include a 12" Steam Distribution Manifold

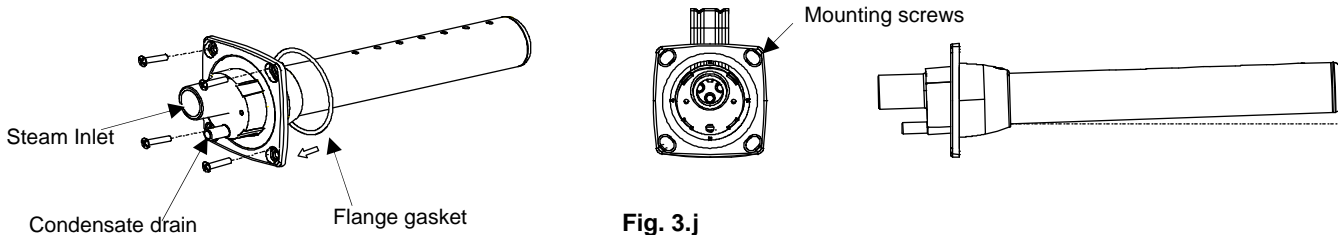

Select an accessible location on the duct, allowing at least 36" of straight duct (no elbows or obstructions) after the point where the manifold will be installed and the clearances can be maintained as per the following drawings. See Fig. 3.j To mount the steam manifold, cut a 2 1/2" hole in the duct. Install the supplied o-ring or apply caulk to the mounting plate of the nozzle. Attach the manifold to the duct using four sheet metal screws. Manifold must level or vertical to condensate outlet to the bottom. Connect the steam and condensate hoses using the clamps supplied.

Note: End support bracket supplied only with 36" and longer manifold.

- IMPORTANT:**
1. Allow 3 feet (1m) of straight duct downstream of the manifold for absorption of the steam.
  2. Always allow 2 feet (0.6m) of straight duct upstream of the manifold. Turbulent air flow may require more.
  3. Duct must be kept warm. Ducts in unconditioned spaces or over faulted ceilings must be well insulated to prevent condensation.

DS 50	Steam outlet dia. mm (in)	30 (1.2")
DS 50 LC	Max capacity kg/h (lb/h)	9 (20)

Steam distributor	Steam inlet dia. mm (in)	Max. capacity kg/h (lb/h)	Length mm (in)
7599 (50-09 steam distributor)	30 (1.2")	15 (33)	300 (11.8)

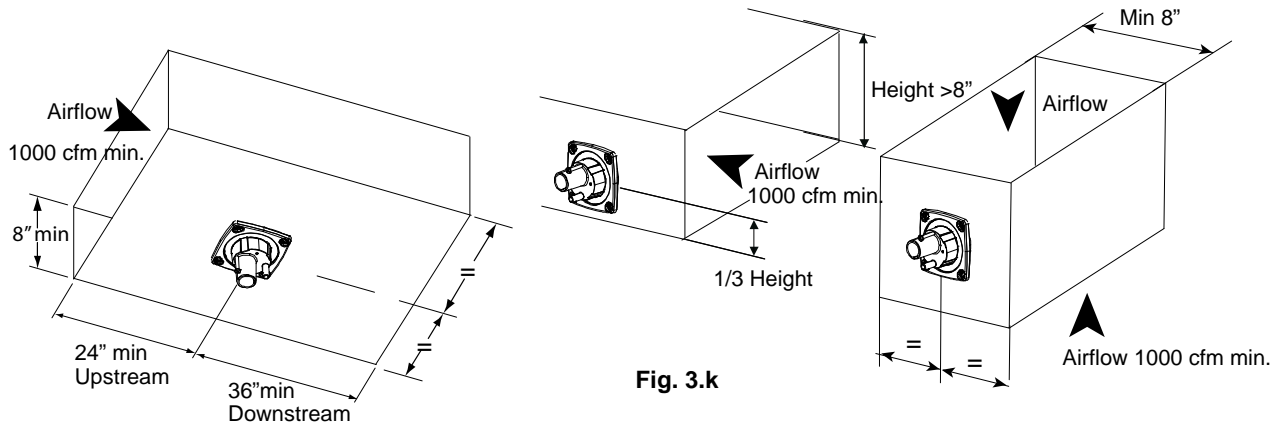

Fig. 3.k

IMPORTANT: Allow 1 M ( 3 feet ) of straight duct downstream of the distributor pipes and nozzles for absorption of the steam. Always allow 0.6M ( 2 feet ) of straight duct upstream of the distributor pipes for evaporation of the steam. Turbulent air flow may require longer lengths.

### 3.4.2 Return Condensate Connection

The return condensate hose from the manifold must be trapped. Coil the hose into a vertical loop and secure it below the manifold. This water trap prevents steam from being released into the hose. Insert the barbed fitting into the end of the hose. Route the manifold drain hose through the top of the humidifier, into the top of the fill cup. This is just above and to the right of the steam cylinder. See. Fig. 3.l

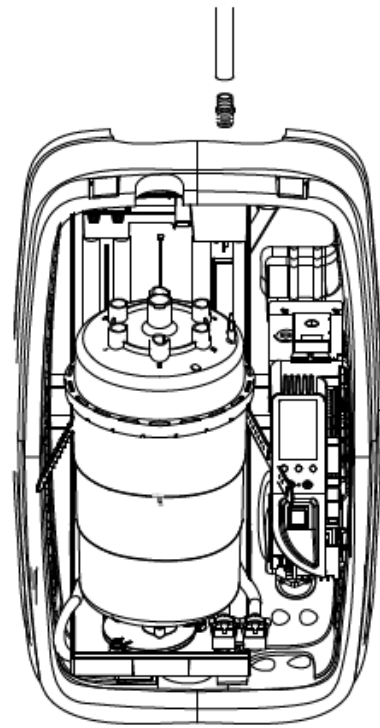

Fig. 3.l

### 3.4.3 Steam Hoses

**IMPORTANT WARNING: NINETY PERCENT (90%) OF ALL OPERATION PROBLEMS ARE CREATED BY IMPROPER STEAM PIPING FROM THE HUMIDIFIER UNIT TO THE DUCT DISTRIBUTOR PIPES.**

To avoid these problems, remember one simple fact when running the steam hose: steam naturally flows up hill, and condensate naturally flows downhill. Run the steam hose or piping to avoid any kinks, sharp elbows, or low spots that could collect or restrict the flow of steam to the distributor pipe, or the flow of condensate back to the humidifier. Support the hose adequately to avoid sags. The following diagrams are to provide you with some guidelines. If you have a situation you are unsure of, *please* contact Technical Support for instructions. Contact information is printed on the back cover.

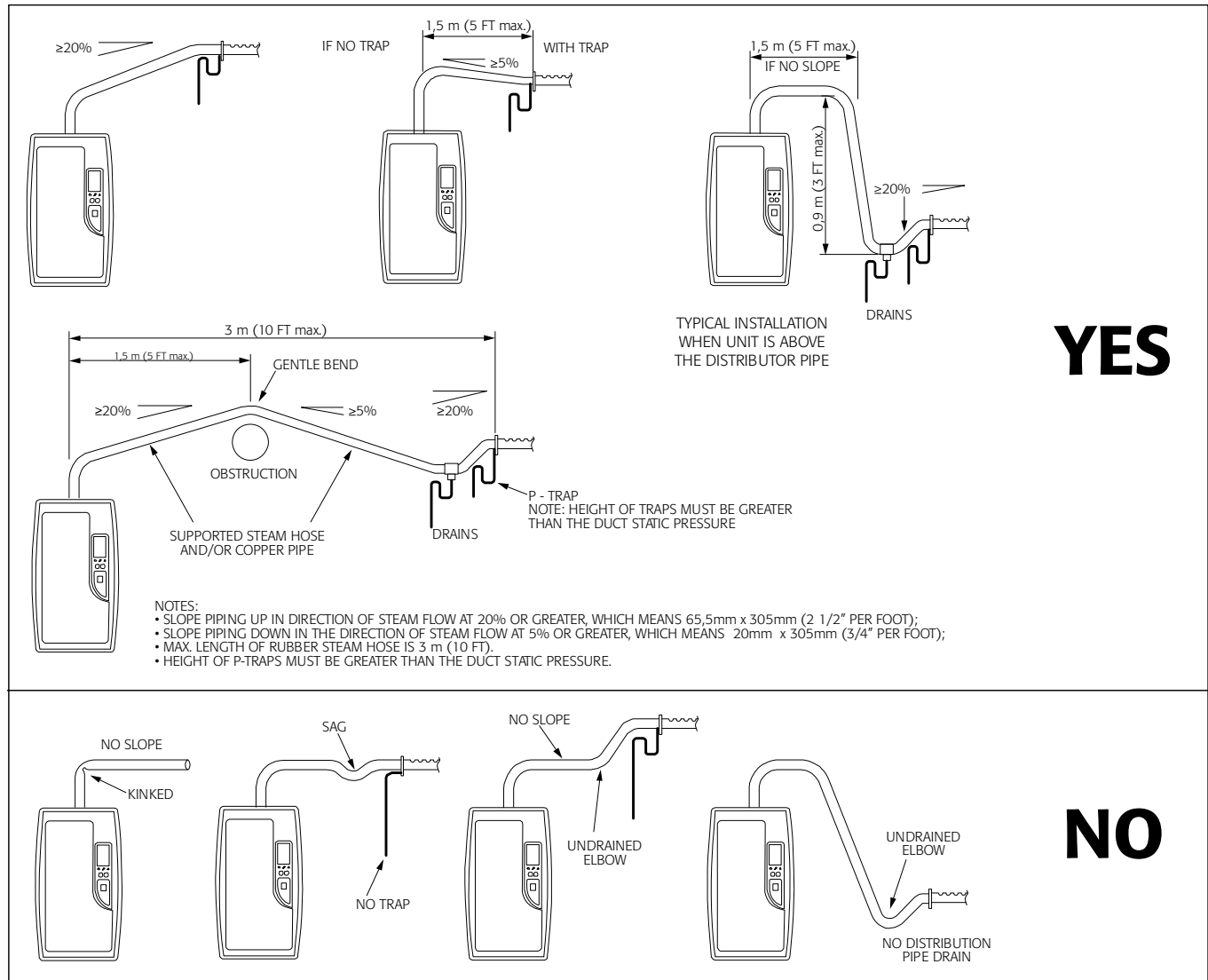

Fig. 3.m

**IMPORTANT: Maximum length of rubber steam hose is 4m (12 feet.). Insulated copper tubing may be up to 6m(20feet) in length. In all cases, minimize sharp bends and elbows. Use 2 - 45° elbows instead of 90°s.**

Hose inner diameter = 1.18" ( 30 mm); Hose outer diameter = 1-1/2" (40 mm).

Installation Items Included:

- Steam hose, 8 feet
- Condansate hose, 9 feet.
- Hose Clamps, 4.
- Steam manifold 12-inch.
- Sheet Metal Screws, 4.
- Water supply tube kit.
- Fill Connector.
- Code Valve Ball valve.
- Pressure Switch.
- GFX50 Humidistat.
- Mounting Template.

### 3.5 Power wiring

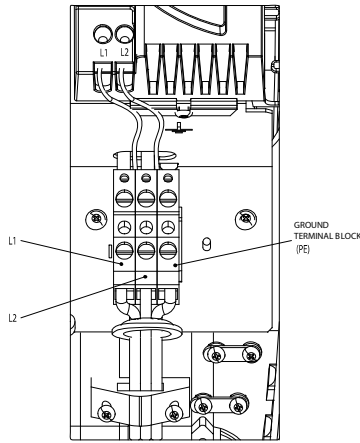

Check that the power supply voltage to be connected matches the value indicated on the rating plate inside the electrical panel.

Insert the power and ground connection cables into the electrical panel compartment using the strain reliefs supplied, and connect to the terminals. An external fused disconnect must be installed. See Fig. 3.o

All wiring must be in accordance with local, state and national electric codes.

**NOTE:** to avoid unwanted interference, the power cables should be kept separate from any control wiring.

**NOTE:** Tolerance allowed on main voltage = -15% to +10%.

Connect power wires to the power terminal. See Fig. 3.p

Fig. 3.m

Model	Power supply (single phase)	Steam Output (lbs/hr – gal/day)	Steam Output (kg/h)	POWER (kW)	CURRENT (A)	EXTERNAL POWER WIRES	EXTERNAL FUSE (A) OR BRAKER
DS50	230Vac 50/60Hz	20 - 58	9	6.9	30	AWG8	40 A / fast blow
DS50LC	230Vac 50/60Hz	20 - 58	9	6.9	30	AWG8	40 A / fast blow

### 3.6 Control wiring

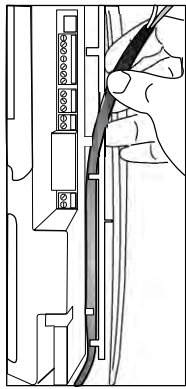

Fig. 3.n

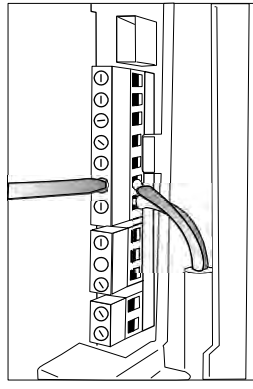

Fig. 3.o

The Elite Steam allows connection of any simple or automatic humidistat, and safety devices such as high-limit humidistat, air flow proving switch, and remote on/off. Included with the humidifier is the GFX50 Modulating Humidistat. The control will increase a steam output if the humidity and setpoint are far apart. It will reduce output as the humidity nears the setpoint. This allows for the most precise humidity control.

For on-off operation the humidifier is operated by the closing of a mechanical humidistat H, or by the closing of a voltage-free remote contact, or alternatively by a combination of both. A pressure switch is always used to confirm blower operation. The diagrams in the figures show the connections to be made on the terminal block, in case of:

Fig. 3.r Operation performed by an external mechanical humidistat or control contact and pressure switch;

Fig. 3.s Operation controlled by the included GFX50 Humidistat and pressure switch.

Contact AB-AB:

- Closed: humidifier enabled to produce when humidistat closes or increases voltage;
- Open: steam production is immediately stopped.
- The remote on/off contact is usually the pressure switch included with the humidifier. The pressure switch NO and C terminals are connected to the AB-AB terminals.
- The remote on/off may include safety switches wired in series with the pressure switch. These may include a high-limit humidistat a relay that closes when fan is running or a downstream cooling coil contact that closes when coil is off.

Contact IN-GND:

If on-off operation is enabled (see section 5.1.1):

- closed: steam production starts if contact AB-AB is closed
- open: steam production is stopped after 5 sec.

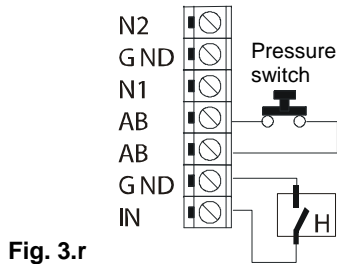

Fig. 3.r

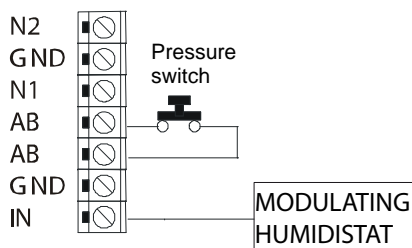
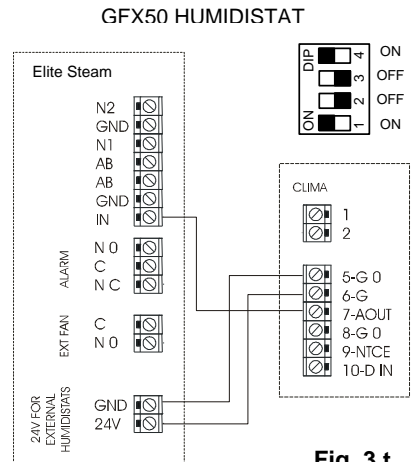

Fig. 3.s

3.6.1 Connect the GFX50 Humidistat for Modulating operation  
 Connect Elite Steam terminals 24V and GND to GFX50 terminals GO5 and G6 respectively. Do not reverse these connections. Connect GFX50 terminal A OUT 6 to Elite Steam terminal IN. See fig. 3.t.

**NOTE:**

1. **MODULATING OPERATION** requires Elite Steam signal type be changed, **SEC. 5.1.1 page 19**
2. The GFX50 is capable of **ON-OFF** operation. See the GFX50 manual.
3. The GFX50 is capable of **Outdoor Temperature Compensation** see the GFX50 manual.
4. The GFX50 is designed to wall mount. It is not intended for duct installation.
5. Reversing the 24V and GND leads will result in humidifier malfunction.

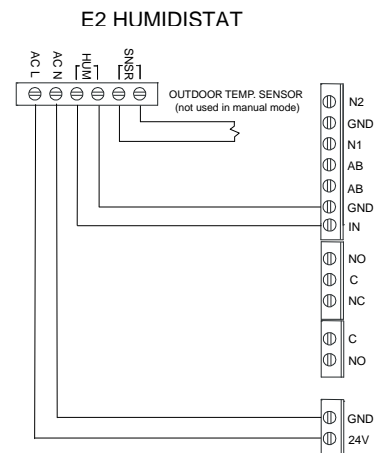

**Fig. 3.t**

3.6.2 Connect the E2 Humidistat ON-OFF Operation  
 Connect Elite Steam terminals 24V and GND to E2 terminals ACL, ACN. Connect E2 terminals HUM to Elite Steam terminals GND and IN.

**NOTE:**

1. To remove humidistat from the base, squeeze the louvered base at the top and bottom. To remove from wall, lift up on the humidistat and pivot top away.
2. Terminal block may be pulled off humidistat for easy connecting.
3. The E2 is capable of **Outdoor Temperature Compensation** see E2 manual.
4. The E2 may be wall or duct mounted.



**Fig. 3.u**

3.6.3 Air pressure, Safety and High Limit Switches  
 Remove the jumper between terminals AB-AB and connect 12500 pressure switch, High Limit Humidistat, safety switch or remote contact in series. If none are to be installed the jumper must remain in place. DO NOT apply any voltage to AB-AB.

3.6.4 Air Conditioner Relay Interlock

Auxiliary DPDT safety relay: Use this method in the following situations:  
 1. To prevent the air conditioner from running when there is a call for humidity. The DPDT relay will open the "Y" circuit and close the "G" circuit for operation while a call for humidity is present. Demand for humidity will override call for cooling.  
 2. In systems using a thermostat where G and Y are a single circuit. The DPDT relay will allow blower operation to occur without back-feeding the compressor. Do not use this method when simultaneous humidification and cooling will be desired. Use a high limit humidistat in to avoid condensation in ductwork. The humidistat should be set to OFF during the air conditioning season if humidification is not desired.

For variable speed or DC systems, consult furnace manufacturer.

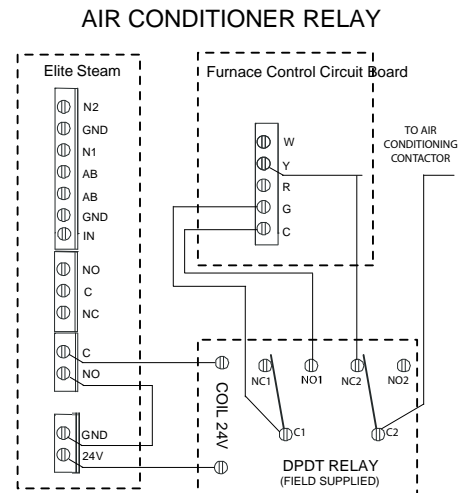

**Fig. 3.v**

Thread control wiring through the bottom of the unit and the strain relief (Fig. 3.m and 3.n) then up the side of the control module to the wiring terminal blocks.

### 3.7 Wiring Connections:

Terminals	Functions	Electrical specifications
L1-L2 -GROUND	Power supply and Ground connections	Power supply 230 VAC 1-phase 50-60Hz 6.9kW
KEY	Programming port	Connecting to Programming port or supervisor
N1-GND- N2 AB-AB	NTC air proving sensor Remote enabling input	Connection to NTC 2K and 10K to 20°C Imposes an external NO contact ; Rmax=300 Ohm; Vmax=33 Vdc; Imax=6mA; humidifier enabled = contact closed
IN-GND	Control signal input	If programmed 0...10V: Input impedance 10 kOhm If programmed ON-OFF: Vmax 33Vdc Imax = 5mA Rmax = 300 Ohm
NC-C-NO	NC alarm contact Common alarm contact NO alarm contact	250V; 8Amp max with resistive load; 4 Amp max with inductive load
NO-C	External fan relay	250V; 8Amp max with resistive load; 4 Amp max with inductive load
24GND	Power for external humidistat	Power supply for external humidistat 24 Vac; 2 Watt
K	Contactor	
TAM	Amperometric transformer	Setting TAM 500 with pin strip

#### 3.7.1 Wiring diagram of controller

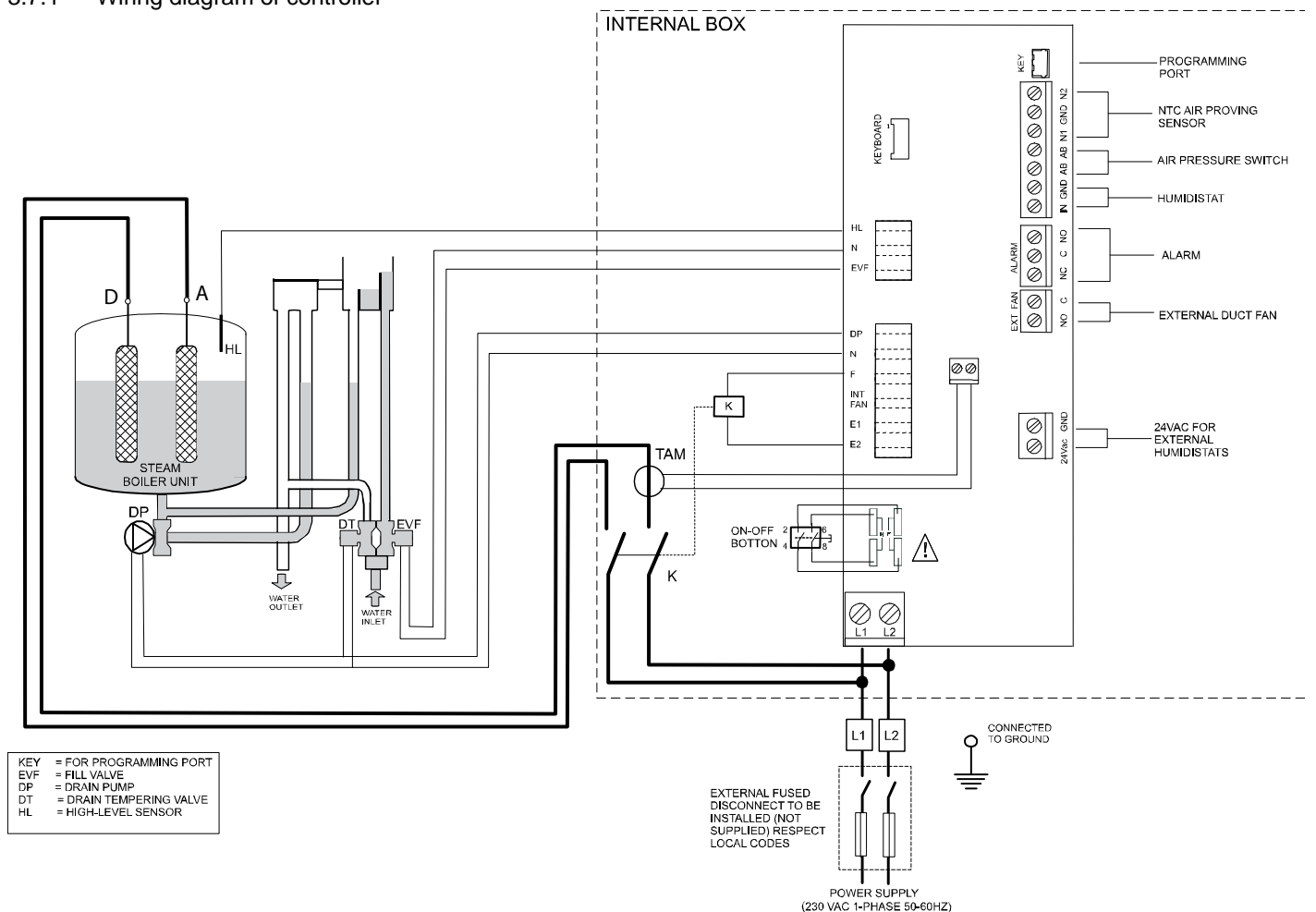

Fig. 3.w

## 4. START-UP

### IMPORTANT WARNINGS:

1. Before starting, check that the humidifier is in perfect condition, that there are no water leaks and that the electrical parts are dry;
2. Do not connect power if the humidifier is damaged or even partially wet!

When installation is completed, flush the supply pipe for around 10 minutes by piping water directly into the drain, without sending it into the humidifier; this will eliminate any scale or residues that may cause foam when boiling.

### 4.1 Startup Checklist

Before starting the humidifier, the following should be checked:

- Water is connected (cold non-softened), the line has been flushed, and external valves are open.
- Drain is connected, run to an open drain, and has a trap under the unit.
- Electricity is connected in accordance with instructions, local codes and data labels in the unit.
- The power fuses are installed and intact.
- All control wiring is done and tested.
- Airflow switch is wired to open on air flow loss.
- Optional hi-limit humidistat is wired to open on humidity rise above set point.
- Unit wires have been checked to make sure they and all connectors are tight from shipping.
- The steam hose(s) are run correctly with no sags or kinks and sloped properly according to the manual.
- Condensate hoses are run correctly with no sags or kinks and sloped properly according to the manual.

### 4.2 The Elite Steam Controller

The *Elite Steam* controller features a comprehensive information display that shows the operation of the system at a glance:

1.	Display is % of nominal capacity
2.	Maintenance
3.	Display is amperage (default)
4.	Steam is being produced
5.	Cylinder filling
6.	Foaming
7.	Water presence inside the cylinder
8.	Cylinder draining
9.	LEDs indicate: power (yellow), operation (green) and alarms (red)
10.	Drain button for manual draining of cylinder and confirming parameter values
11.	ON/OFF button
12.	Reset button to reset alarms and access parameters
13.	Level of output: 33%, 66%, 100%
14.	Fan relay is activated

The DS 50 / DS 50 LC is now ready to operate.

### 4.3 Starting the Elite Steam

- Insure that the external power is turned on.
- Push the top part of the On/Off button so that the I part is in. The yellow Power LED will be lit. The Elite Steam is now ready to operate.
- When there is a call for humidity, DS 50 / DS 50 LC will close its power relays and send power to the electrodes in the plastic steam generator. The green Operation LED will light, indicating that operation has begun.

### 4.4 Starting with a new cylinder

When starting with a new cylinder, you should activate the cylinder cleaning function as follows:

1. Switch Elite Steam off.
2. Press and hold both buttons, “reset” and “drain”, and switch DS 50 / DS 50 LC back on.

When the wrench blinks  then release the two buttons.

3. Press and hold “reset” until the display shows 04.

**WARNING:** DO NOT confirm any value higher than 04. If 05 or higher is displayed, press “reset” until the display goes back to the normal operating mode and restart from step

4. Press “drain” (minimum 1 second): the cleaning starts.

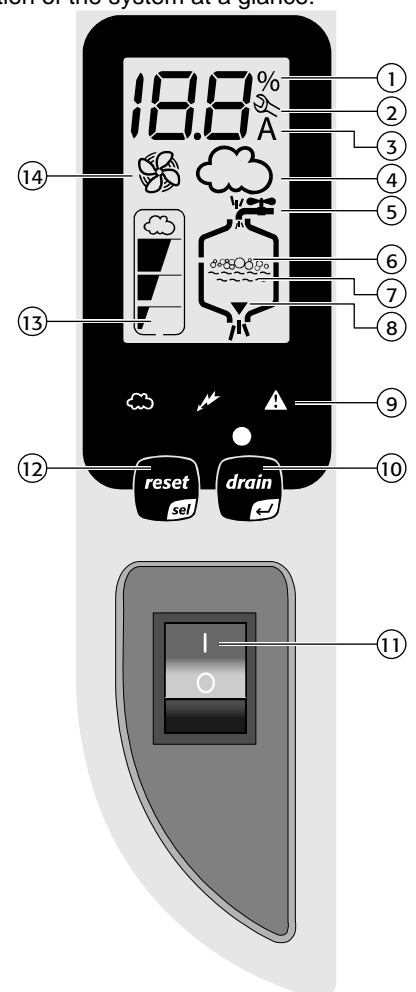

During the cleaning, the electrodes are powered and water is filled in until it touches the high-level sensor or the phase current equals 20A, whichever occurs first. After either of the events is detected, the boiler is fully discharged with the electrodes un-powered (the drain pump and the drain tempering valve are activated for 3 minutes). Warming the filling water helps washing out any mould release or dirt. General Filters, Inc. recommends to do two cleanings when starting a new boiler. After the cleaning ends, the humidifier starts the regular duty. When starting the unit with a new or empty cylinder, it may take a significant amount of time (hours) for the unit to build up enough mineral concentration to reach rated capacity. This time can be shortened by the addition of Alka-Seltzer through the steam outlet on top of the cylinder.

## 5. OPERATING the Elite Steam

### 5.1 Displaying Information

By pressing the “reset” button for 2 seconds, the display will loop from amperage to production in % of the maximum production to the hour counter and back to amperage:



1. **Amperage:** it is the value of the current that flows through the water making it boiling off (default display)
2. **Production %:** it is the current production expressed as a percentage of the humidifier’s capacity
3. **Hour counter,** expressed in tens; for instance, when the display shows 13 the real hour value will be between 130 and 139 hours.

#### 5.1.1 Select Signal Type

The DS50 is preset for the included E Series humidistat (signal type 0). If the ON-Off operation is used, this section may be omitted. If another humidistat is used, review this section to see if changes are needed.

1. Switch Elite Steam off.
2. Press and hold both buttons “reset” and “drain” and switch Elite Steam back on. When the wrench blinks,  release the 2 buttons.
3. Press “Reset” until the display shows 02. WARNING: DO NOT confirm any value higher than 04. If 05 or higher is displayed, press “Reset” until the display goes back to the normal operating mode and restart from step 1.
4. Press “drain” (minimum 1 second) to confirm: the display shows “P1” then the current signal type and “set”
5. Press “Reset” to change signal type between 0 and 1:  
 0 = On-Off humidistat such as the GeneralAire “M” or “E” series humidistat.  
 1 = external 0...10 Vdc modulating signal such as the GeneralAire ADCD series humidistat
6. Press “drain” (minimum 1 second) when done to confirm the new value of P1 and exit to the normal operating mode.
7. Switch Elite Steam off: you can now proceed with connecting the control wiring.

### 5.2 Changing The Maximum Production

The maximum production can be adjusted between 20% to 100% of the nominal production in steps of 5% in order to suit the environment characteristics. DS50 and DS50L Maximum production is factory set at 70%.

1. Switch Elite Steam off.
2. Press both and hold both buttons “Reset” and “Drain” , and switch Elite Steam back on. When the wrench blinks;  release the 2 buttons.
3. Press “reset” until the display shows 01. WARNING: DO NOT confirm any value higher than 04. If 05 or higher is displayed, press “Reset” until the display goes back to the normal operating mode and restart from step 1.
4. Press “drain” (minimum 1 second) the display shows “P0” then the current Maximum Production Percent and “set”.
5. Press “reset” to change the Maximum Production in steps of 5% between 20% and 100%.
6. Press and hold “drain” (minimum 1 second) when done to confirm the new Maximum Production and exit to the normal operating mode.

### 5.3 Activating Manual Drain

Press and hold the “drain” button on the front of the unit until the cylinder is drained. Note: Water will continue to flow from the tempering valve after the cylinder is empty.

### 5.4 Resetting the hour counter

The hour counter should be reset every time the cylinder is changed in order to reset and restart the internal maintenance timer:

1. Switch Elite Steam off.
2. Press and hold both buttons “Reset” and “Drain” and switch Elite Steam back on. When the branch  blinks; release buttons.
3. Press and hold “reset” until the display shows 03. WARNING: DO NOT confirm any value higher than 04. If 05 or higher is displayed, press “reset” until the display goes back to the normal operating mode and restart from step 1.
4. Press “drain” (minimum 1 second) to confirm: the hour counter will be reset at once and the humidifier will go back to the normal operating mode.

## 5.5 Humidistats

Several GeneralAire humidistats may be used with the Elite Steam Humidifier; GFX50 (included)

Allows Modulating or On-Off operation. Is capable of Outdoor Temperature Compensation, and has other programmable functions. Backlit LCD display.

E2 (optional)

On-Off operation only. Is capable of Outdoor Temperature Compensation. LCD display.

M3 and SCX3 (optional)

Manual, On-Off operation only.

For detailed installation, programming and operating instructions, please see the Humidistat's Operating Manual.

**WARNING:** Do not allow excess humidification. Excess humidity can cause condensation and enable mold and mildew growth.

## 5.6 Alarms

In the event of an alarm, the red alarm LED will flash, the alarm relay will close, and the alarm code will flash in the display. Multiple alarms will flash in sequence, alternating with the main display. Pressing the sel button for 2 seconds will reset the alarms, although still active alarms will continue to display.

Display	Description	Action	Red Led	Alarm Relay	Notes
--	Remote on-off open	Unit disabled	Off	Off	Check Pressure Sw. circuit, AB-AB
EE	Internal memory error	Unit disabled	On	On	Contact Factory
E0	Control board configuration not valid	Unit disabled	On	On	Contact Factory
E1	High current alarm	Unit disabled	On	On	Turn off, check connections, check cylinder (no limescale bridges between electrodes, no electrodes short-circuited)
E2	Low production, low supply water conductivity or excessive foam/limescale in the cylinder	Unit disabled. Press "reset/sel" key for 1 seconds to reset.	On	On	Check supply water conductivity (too low?), replace the cylinder.
E4	Fill alarm, unable or slow fill (current does not increase within timeout)	Press "reset/sel" key for 1 seconds to reset, otherwise the warning will be reset automatically every 10 minutes until the supply water is available again.	On	On	Check water supply and fill valve; check drain pump for leakage
E5	Drain alarm, unable to drain (current does not decrease within timeout)	Press "reset/sel" key for 1 seconds to reset	On	On	Check drain pump and drain connection
E6	Cylinder exhausted (critical performance detected)	The warning is automatically reset if DS 50 / DS 50 LC can produce the demand, otherwise turn off and then on.	Off	Off	Change cylinder (urgent)
E7	Foam detected	Press "reset/sel" key for 1 seconds to reset	Off	Off	If it continues, do some cleaning cycles (read chap. "Starting with a new cylinder")
E8	Cylinder lifetime expired (2000 hours)	Reset the hour counter (read chap. Resetting the hour counter")	Off	Off	Change the cylinder.
E9	High controller temperature (above 176 °F / 80 °C)	The warning is automatically reset if the temperature decreases below 176 °F / 80 °C.	Off	Off	Check the ambient temperature, replace the controller.

## 6. TROUBLE SHOOTING

Problem	Causes	Solutions
The humidifier does not turn on	<ol style="list-style-type: none"> <li>1. No electrical power</li> <li>2. On/off switch of the humidifier in position 0 (open)</li> <li>3. Control connectors improperly connected</li> <li>4. Blown fuses</li> <li>5. Transformer failure</li> </ol>	<ol style="list-style-type: none"> <li>1. Check the safety devices upstream from the humidifier and the presence of power</li> <li>2. Close the switch on the panel: position I</li> <li>3. Check that connectors are properly inserted in terminal block</li> <li>4. Check the condition of fuses</li> <li>5. Check that the proper voltage is connected and turned on</li> </ol>
The humidifier does not start operation	<ol style="list-style-type: none"> <li>1. Remote ON/OFF contact open</li> <li>2. The humidistat has not been connected correctly</li> <li>3. Humidistat failure</li> <li>4. Control signal not compatible with the type set</li> <li>5. Value measured by the sensor/s higher than the corresponding set point</li> </ol>	<ol style="list-style-type: none"> <li>1. Close ON/OFF contacts</li> <li>2. Check the external connection</li> <li>3. Replace the humidistat</li> </ol>
The humidifier fills with water without producing steam	<ol style="list-style-type: none"> <li>1. High steam back pressure</li> <li>2. Fill valve strainer clogged</li> <li>3. Mineral in the fill cup</li> <li>4. Drain solenoid valve leaking</li> </ol>	<ol style="list-style-type: none"> <li>1. Check that the steam hose is not kinked or sagging, trapping condensate</li> <li>2. Clean the fill valve strainer</li> <li>3. Clean the fill cup</li> <li>4. Check for voltage at the drain solenoid valve and/or drain solenoid replacement</li> </ol>
The humidifier wets the duct	<ol style="list-style-type: none"> <li>1. The distributor is not installed correctly (too near the top of the duct or the condensate return is blocked)</li> <li>2. Air flow rate is too low</li> <li>3. Humidifier active when the fan in the duct is off</li> </ol>	<ol style="list-style-type: none"> <li>1. Check that the steam distributor is installed correctly</li> <li>2. Increase air flow in duct or decrease PO maximum steam production setting</li> <li>3. Check the connection of the device (flow switch or differential pressure switch) controlling the humidifier to the ventilation in the duct</li> </ol>
The humidifier wets the floor below	<ol style="list-style-type: none"> <li>1. The humidifier drain is blocked</li> <li>2. The supply water or overflow circuit has leaks</li> <li>3. The condensate drain pipe does not bring the water back to the drain pan</li> <li>4. The steam hose is not properly fastened to the cylinder</li> </ol>	<ol style="list-style-type: none"> <li>1. Clean the drain assembly and pan</li> <li>2. Check the entire water circuit</li> <li>3. Check the correct position of the condensate drain hose in the drain pan</li> <li>4. Check the fastening of the hose clamps on the steam outlet</li> </ol>

**Tab. 6.a**

Problem	Causes	Solutions
<b>Water in the cylinder turns black</b>	<ol style="list-style-type: none"> <li>1. Minerals in the cylinder have overconcentrated and are deteriorating the electrodes.</li> </ol>	<ol style="list-style-type: none"> <li>1. Check for sags &amp; kinks that could trap condensate in the steam hoses that could cause a back pressure on the cylinder.</li> <li>2. Check the duct static pressure.</li> <li>3. Check the fill valve and inlet strainer.</li> <li>4. Check the drain pump operation.</li> <li>5. Correct installation problems and replace cylinder.</li> </ol>
<b>Heavy arcing occurs within hours of startup</b>	<ol style="list-style-type: none"> <li>1. The feed water contains large amounts of Iron, Copper or other conductive contaminants.</li> </ol>	<ol style="list-style-type: none"> <li>1. If you are using a softener. Discontinue use.</li> <li>2. Check the electrodes in the cylinder to be sure they were not damaged in shipping.</li> </ol>
<b>Humidifier continuously fills and drains without producing steam</b>	<ol style="list-style-type: none"> <li>1. Mineral has bridged between the electrodes.</li> <li>2. There is back pressure from the steam hoses or duct.</li> <li>3. The flow regulator in the fill valve is broken or out of place.</li> <li>4. Water conductivity is very high.</li> <li>5. Water is foaming excessively.</li> </ol>	<ol style="list-style-type: none"> <li>1. Clean or replace the cylinder.</li> <li>2. Check the steam hoses for kinks or gullies that might be trapping condensate.</li> <li>3. Replace the fill valve.</li> <li>4. Consider using a mix of demineralized water with raw water.</li> <li>5. Check cylinder - replace if exhausted. If feed water contains silica or nitrates, install a 1 micron water filter.</li> </ol>

**Tab. 6.b**

## 7. MAINTENANCE

### 7.1 Periodic checks

- After one hour of operation: Check that there are no significant water leaks.
- Every fifteen days or no more than 300 operating hours: Check operation, that there are no significant water leaks and the general condition of the cylinder. Check that during operation there is no arcing between the electrodes.
- Every three months or no more than 1000 operating hours: Check operation, that there are no significant water leaks and, if necessary, replace the cylinder. Check that there are no blackened parts of the cylinder. If there are blackened parts of the cylinder, check the condition of the electrodes, and if necessary replace the cylinder.
- Annually or no more than 1990 operating hours: Replace the cylinder.

**CAUTION: ALWAYS DISCONNECT THE MAIN POWER BEFORE DOING MAINTENANCE!**

**CAUTION:** always disconnect the main power before touching the cylinder in the event of leaks, as current may flow through the water.

### 7.2 Cylinder maintenance

The life of the cylinder depends on a number of factors, including: the amount and type of mineral in the water, the correct use and sizing of the humidifier, and the output, as well as careful and regular maintenance. Another factor affecting cylinder life is Maximum Production, the higher the production rate the shorter the cylinder life; for this reason the DS-50 are preset from the factory at 70%. Further reductions in maximum production will extend cylinder life. See figure 7.a

#### IMPORTANT WARNINGS

The humidifier and its cylinder contain live electrical components and hot surfaces, and therefore all service and/or maintenance operations must be performed by expert and qualified personnel, who are aware of the necessary precautions. Before performing any operations on the cylinder, check that the humidifier is disconnected from the power supply. Remove the cylinder from the humidifier only after having drained it completely using the manual “drain” button or procedure. Check that the model and the power supply voltage of the new cylinder correspond to the data on the rating label.

#### 7.2.1 Replacing the cylinder

**IMPORTANT WARNING:** the cylinder may be hot. Allow it to cool before touching it or use protective gloves.

To replace the cylinder:

1. Completely drain the cylinder by pressing and holding the “**drain**” button until the cylinder is empty;
2. Turn the humidifier off and disconnect the main power;
3. Remove the cover;
4. DS Models:
  - Remove the steam hose from the cylinder;
  - Flip up the cylinder holding belt and lift the cylinder out of the unit;
5. Disconnect the distributor from the cylinder and lift the cylinder out of the unit;
6. Disconnect the electrical connections from the top of the cylinder;
7. Install the new cylinder in the humidifier by performing the previous operations in reverse

**CAUTION:** Do not tighten the 1-1/4” hose clamp so tight that it crushes the cylinder outlet

**WARNING:** connect the gray wire with the electrical connections “A” on the top of the cylinder and connect the black wire with the electrical connections “D” on the top of the cylinder.

#### 7.2.2 Maintenance of the other plumbing components

**IMPORTANT WARNINGS:**

- External power must always be disconnected when performing any maintenance on the humidifier.
- When cleaning the plastic components do not use detergents or solvents;
- Scale can be removed using a solution by using vinegar or a weak solution of acetic acid and a soft brush; then rinse the cylinder thoroughly with fresh water.

#### Cleaning the fill valve:

After having disconnected the cables and the hoses, remove the valve and check the condition of the inlet filter; clean if necessary using the same cleaning solution as for the steam cylinder and a soft brush.

#### Cleaning the drain pump:

Remove the valve body, clean if necessary using the same cleaning solution as for the steam cylinder and a soft brush.

#### Cleaning the drain pan:

Clean the pan of any mineral deposits and check that the water flows freely from the pan to the drain at the drain pump.

**Cleaning the supply, fill, overflow pipes:** Check that these are clear and clean or replace if necessary.

**IMPORTANT WARNING:** after having replaced or checked the plumbing, check that components have been reconnected correctly with the proper seals. Re-start the humidifier and perform a number of cleaning cycles (from 2 to 4, read chap. “Starting with a new cylinder”), then check for any water leaks.

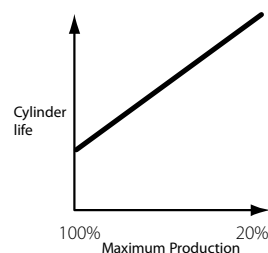

**Fig. 7.a**

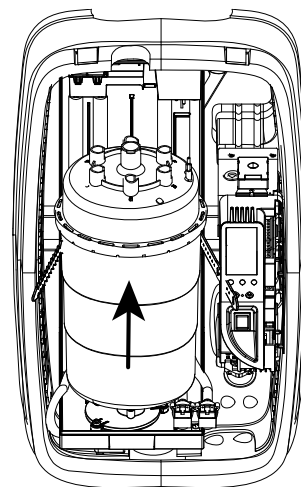

## 7.3 Replacement Parts

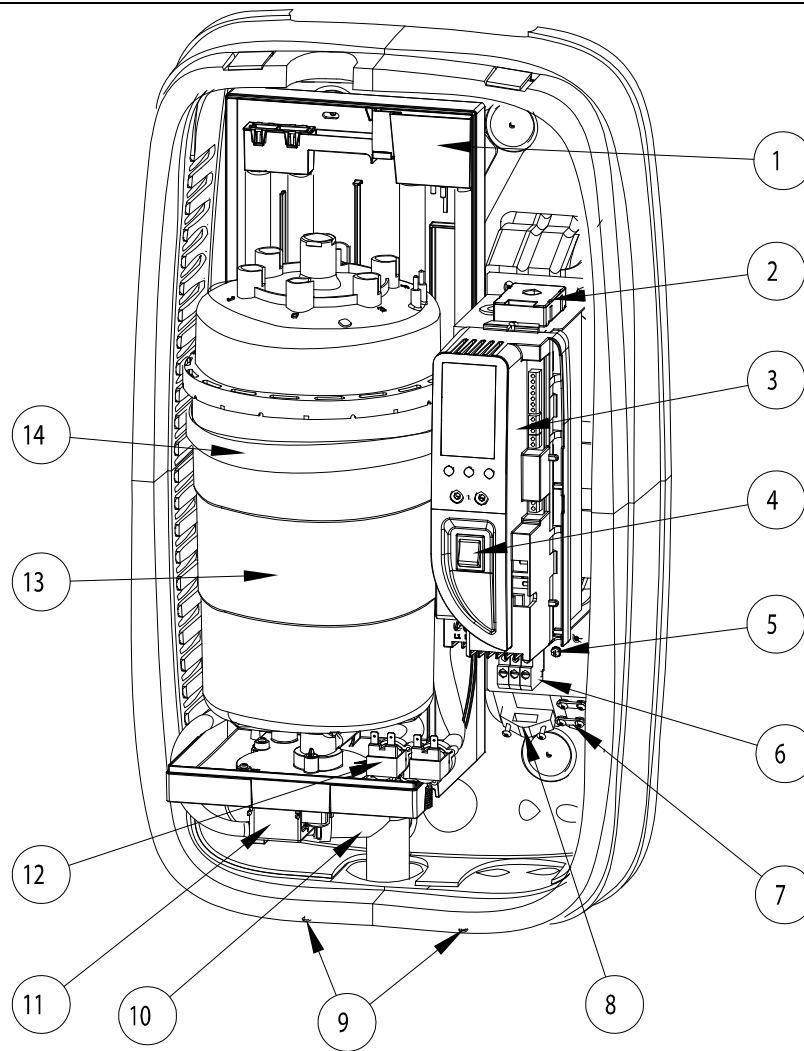

ITEM	PART NO.	MODEL	DESCRIPTION
1	7638	50-22	fill cup
2	7656	50-26	current sensor
3	7621	50-01	control module 230Vac
4	7551	35-18	on/off switch
5-6	7652	50-18	power terminal block kit w/cover
9	7626	50-25	cover screws kit
10	7542	35-21	90deg drain adapter
11	7623	50-04	drain pump assembly
12	7622	50-03	fill/tempering valve assembly
13	7624	50-14	cylinder
13	7635	50-15	cylinder low conductivity
14	7654	50-20	cylinder support strap
	7637	50-17	internal wiring kit
	7639	50-23	internal hose kit
	7633	50-05	installation instructions
	7501	20-04	fill connector
	7636	50-16	internal filter and gasket kit ds50
	7655	50-21	silent contactor
	7657	50-10	hardware kit ds50
7			2 - Small cable clamp
			4 - Screws for small cable clamp
8			1 - Large cable clamp
			2 - Screws for large cable clamp
10			1 - 90 Deg drain adapter
			1 - Kit of 4 Mounting screws and anchors

## 8. TECHNICAL SPECIFICATIONS

Steam flows, VAC, kW	<b>20 lbs/hr (9 kg/h): 230 VAC 1-phase 50-60 Hz, 6.9 kW</b>	Notes
Outlet pressure limits	<b>5.4 in WC / 1350 Pa</b>	For duct only
Dimensions (mm )	<b>31" x 18" x 11.4" (790 x 460 x 290 mm)</b>	(Height x Width x Depth)
Weight empty/packaged/installed with water	<b>24/29/51 lbs. (11/13/23 kg)</b>	
IP class	<b>IP20</b>	
Electrode power cables	<b>8 AWG</b>	
Power contactor	<b>63 Amp</b>	
Ground connection	<b>Terminal block</b>	
Input water type	<b>Potable water</b>	no demin. or softened water
Conductivity range	<b>125-1250 µS/cm</b>	Special cylinders for cond. < 350 µS/cm
Water fill connection	<b>1/4" O.D. Compression</b>	Adapter to 3/4" FPS
Water fill - instant flow	<b>0.22 – 0.3 gpm (0.825 – 1.1 l/min)</b>	
Drain connection	<b>1.25" O.D. (32 mm)</b>	Adjustable from horizontal to vertical. May be from back or bottom of unit.
Drain water temp	<b>&lt; 140°F (&lt; 60°C)</b>	drain tempering device
Drain flow	<b>Max 5.1 gpm (max 21 l/min)</b>	
Serial communication	<b>RS485</b>	









**GENERAL FILTERS, INC.**  
43800 GRAND RIVER AVE  
NOVI, MICHIGAN 43875-1115  
248-476-5100  
[WWW.GENERALAIRES.COM](http://WWW.GENERALAIRES.COM)

**CANADIAN GENERAL FILTERS, INC.**  
400 MIDWEST POAD  
SCARBOROUGH, ONTARIO M1P3A9  
416-757-3691  
[WWW.CGFPRODUCTS.COM](http://WWW.CGFPRODUCTS.COM)

Agency:

Form 50-05 Rev. 1.2