

This Owner's Manual is provided and hosted by [Appliance Factory Parts](#).



COOKSHACK SM045 Owner's Manual

[Shop genuine replacement parts for COOKSHACK
SM045](#)



[Find Your COOKSHACK Grill Parts - Select From 13 Models](#)

----- Manual continues below -----



Cookshack SM025 & SM045 Operator's Manual

Not intended for use in a commercial setting.

Please read this entire manual for installation and use of these smoker ovens. Failure to follow these instructions could result in property damage, bodily injury or even death.

SAVE THESE INSTRUCTIONS.



SM025



SM045

Version 18.03.19

Revision Date: 03/19/2018

Serial Number: _____

Purchase Date: _____

Dear Customer,

Thank you for choosing Cookshack! Your smoker oven will produce great barbecue and smoked foods. It is easy to operate, clean and maintain. Use this Operator's Manual to familiarize yourself with the smoker oven and its operation. If you have any questions or problems not covered in this manual, call us at 1.800.423.0698 Monday through Thursday, 9:00 a.m. to 4:00 p.m. CST, Friday 9:00 a.m. to 2:00 p.m. or email us at info@cookshack.com. You can also join the Cookshack Barbecue Forum which has participation by both Cookshack customers and team members.

Always observe safe operating practices when using the smoker. It is an electrical appliance and is therefore potentially dangerous!

COOKSHACK, INC. assumes no responsibility for results of careless and dangerous operation of COOKSHACK smoker ovens or other products. All warranties are null and void if the practices described in the Operator's Manual are not observed.

Read the following instructions thoroughly and completely before using your Cookshack Smoker Oven. Be certain that you understand completely how it operates before attempting to operate it. Additional sources of information can be found on our website at www.cookshack.com.

With these precautions in mind, enjoy your smoker oven and the delicious foods it will produce.

Stuart Powell



President and CEO
Cookshack, Inc.

support@cookshack.com | sales@cookshack.com
www.cookshack.com | www.pelletcooker.com
Sales: (580) 765-3669 | Customer Service: (800) 423-0698
Fax: (580) 765-2223



Contents

Important Safeguards.....	4
Fire/Burn Precaution.....	4
Electrical/Wire Precaution.....	4
Tipping Precaution.....	5
Water Precaution.....	5
Miscellaneous/Child Precaution.....	5
Included Equipment.....	6
Registration Card.....	6
Location.....	6
Ventilation.....	7
Electrical Power Connections.....	7
Assembly.....	7
Install the Casters.....	7
Install the Control Head.....	7
Season Your Smoker.....	8
Wood Selection.....	8
Operating Instructions.....	9
Loading/Unloading.....	10
Shutdown Procedure.....	10
Cleanup.....	11
Maintenance.....	11
Two Year Limited Warranty.....	12
Return Merchandise Policy.....	13
SM025/SM045 Common Parts List.....	15
SM025 Wiring Diagram.....	16
SM025 (240V Export) Wiring Diagram.....	17
SM045 Wiring Diagram.....	18
SM045 (240V Export) Wiring Diagram.....	19

Important Safeguards

Read all instructions. SM025 and SM045 are for household use only.

Fire/Burn Precaution

Do not touch hot surfaces. Always use handles or knobs.

Do not leave hot oven unattended with door open.

Unplug from outlet when not in use and before cleaning. Allow to cool before putting in or taking off parts.

Extreme caution must be used when moving an appliance containing hot grease or other hot liquids.

Do not store combustible material near your smoker oven.

Never store or use gasoline in the vicinity of this cooker or use to ignite this cooker.

Electrical/Wire Precaution

Do not immerse cord, plugs or any part of unit in water or other liquid.

Do not operate any appliance with a damaged cord, plug, or after the appliance malfunctions, or has been damaged in any manner. Contact Cookshack customer service if repairs are needed.

Do not let cord hang over edge of table or counter, or touch hot surfaces.

Extension cords may be used if care is exercised in their use. If an extension cord is used:

- The marked electrical rating of the extension cord should be at least as great as the electrical rating of the appliance AND should be a grounding-type, 3-wire cord.
- Outdoor extension cords should be used with outdoor products and are marked with suffix letters "W-A" and with a tag stating "Suitable for Use with Outdoor Appliances."

CAUTION: To reduce the risk of electric shock, keep extension cord connections dry and off the ground.

CAUTION: To ensure continued protection against risk of electric shock, connect to properly grounded outlets in accordance with local codes or with the National Electrical Code ANSI/NFPA 70-1990 only.

Tipping Precaution

Use caution when moving unit. Tipping too far toward back could cause the unit to fall, causing serious injury.

Water Precaution

Do not expose to rain. We recommend a full-length cover. Cookshack Part numbers for the SM025 and SM045 covers are:

- PV031-SM025
- PV032-SM045
- PV033-SM025 with optional cart
- PV033-SM045 with optional cart

Miscellaneous/Child Precaution

Service should be performed by an authorized service representative only.

The use of accessory attachments not recommended by the appliance manufacturer may cause injuries.

Do not use fuel such as charcoal briquettes with this appliance.

Do not use appliance for other than intended use.

Close supervision is necessary when any appliance is used by or near children. Store this product indoors and out of reach of children when not in use.

SAVE THESE INSTRUCTIONS

REMEMBER

**WHEN YOU REGISTER YOUR UNIT WITH
COOKSHACK, YOU GET 10% OFF YOUR NEXT ORDER
OF SAUCES, ACCESSORIES, SPICES AND MORE!
SIMPLY RETURN THE REGISTRATION CARD
INCLUDED WITH YOUR UNIT OR GO ONLINE TO
WWW.COOKSHACK.COM/REGISTRATION**

Included Equipment

After removing your smoker oven from its packaging, you should then open the smoker and make sure each item is included along with your manual.

- Control Panel – PV554
- Meat Probe - PV530
- Foil Drip Pan – PV703
- Smoking at Home Cookbook – LT161
- Box of Wood Chunks
- Side Racks – PM030
- Grills – PV003
 - SM025-2
 - SM045-3
- Box of Casters (4) – PV161
- Wood Box – PA019
- Registration Card

Registration Card

Registering your smoker by filling out the registration card is a very important part of caring for your smoker. We continue to improve the units we make for you. Part numbers installed in the unit may change. By registering, our Customer Service Department will be better equipped to service your unit. Registration Methods include:

- Register on our website at www.cookshack.com/registration
- Fill out Registration Card and mail back to us
- Call customer service at 1-800-423-0698.

Once you register, you will receive a 10% discount on your next order of Cookshack barbecue sauce, spices, wood or accessories.

Location

Choose a dry, sheltered and well ventilated location. Do not expose the smoker to rain. Do not place flammable or combustible materials on or adjacent to the smoker.

Ventilation

Operating the smoker indoors is not recommended because a small amount of smoke will escape the smoker from the top of the unit. If you store this smoker in a garage or storage building, it is a good idea to move it outside when cooking. Do not cover the vent hole. This will cause thermostat failure and void your warranty.

Electrical Power Connections

Your Cookshack smoker has a single burner system which uses 120V AC power (US models only, all export models use 240v). Connect the smoker to the power supply by plugging the power cord into a standard, 3-prong receptacle that is protected by a breaker or fuse rated at 15 amperes. A long or light-duty extension cord will reduce the efficiency of the heating element and food will take longer to cook.

Assembly

The only assembly required for your SM025/SM045 is the installation of the casters (wheels) onto the bottom of the smoker and the control panel on top.

Install the Casters

Remove all interior accessories from smoker.

Using two people, lay the smoker on its back.

Note: The weight of the smoker is more than 50 lbs. and serious injury can occur if smoker is lifted by only one person.

Please be sure not to lay smoker on a surface that will scratch the metal. We recommend that you find a carpeted area in order to install the casters.

Your smoker should have shipped with four locking casters. Turn all casters clockwise until they are fully screwed in so that the smoker will be level. Using two people, return your smoker to the standing position. Place the side racks and grills back in your smoker.

Install the Control Head

First remove the 8 Phillips head screws from the top of the smoker that align with the control head holes. Plug the control connectors into the smoker (1 white and 1 yellow – ensure polarity on yellow plug is correct). Place the control head on top of smoker aligning the holes and secure it in place with the 8 Phillips head screws. Be careful not to over tighten the screws. The screws only need to be tight enough to keep the control head secure.

Season Your Smoker

The interior of your smoker needs to be "broken in" or seasoned before you cook your first load of meat:

- Put 2-3 ounces (1 piece) of included wood chunks inside the wood box and insert over the heating element.
 - Never place more than 4 ounces of wood in the smoker. 4 ounces is going to be a HEAVY smoke flavor. We recommend starting with 2 ounces for your first cook. From there, you can add or remove wood to meet your taste.
- Once in the proper position, let the smoker run without meat for a minimum of 4 hours at 275°F.

Do not use your smoker without the wood box insert in the proper position.

Wood Selection

As you progressively learn how to use your smoker, you will become more comfortable with choosing the amount of wood to place in your smoker. It is wise to start with a small amount of wood at first and increase as necessary until you have the smoky flavor you prefer. Personal taste dictates the amount of wood you use and this varies from person to person, hence the lack of hard and fast rules.

Try starting with 2 ounces of wood for your first smoke and adjust upward if you want a smokier flavor for later cooks. Remember, normally one chunk of wood can weigh anywhere from 2 to 4 ounces.

You may use any fruit or nut hardwood in your smoker, as long as it has good flavoring abilities. The most popular woods for smoking are hickory, mesquite, apple and cherry. All of these are available from Cookshack at (800)423-0698. Other regional favorites are alder, beech, pecan, maple, oak, buttonwood and mangrove. Use local woods only if logs are selected and sized properly.

Operating Instructions

Before starting your smoker, be sure to:

Optional: For easy clean up, line the bottom of the smoker and the top of the wood box with heavy duty aluminum foil. Press through the foil to create a hole corresponding with the drain hole located on the floor of the smoker.)

1. Slide the drip pan provided beneath the drain hole under the smoker as well as under the trough drain hole located at the front of the smoker.
2. Insert the wood box into its proper position once loaded with desired amount of wood.
3. Do not change the wood box's position during the cooking cycle. The wood box covers the burner and protects it from grease dripping onto the heat source.

To use the Meat Probe:

1. Plug probe into the side of the control housing (ensure locking ring is tightened down).
2. Drop the probe through the vent hole and place it in the largest piece of meat.
3. The meat temperature will show on the bottom display of the controller.

The controller will not register temperatures below 50°F or above 300°F. In either circumstance where temperature is below or above this range, the probe section will read "HIGH."

1. To set the Temperature:
2. Press the on/off button
3. Press the up or down arrows until the top display reads your desired cooking temperature.
4. Heat up will take anywhere from 30 to 90 minutes, depending on the load.
5. Do not preheat the smoker unless preheating is specified in the recipe you are using.
6. Note: It is normal for the smoker to exceed the temperature that it is set for at first.

Loading/Unloading

The maximum cooking capacity of the SM025 is 25 lbs. of heavy cuts of meat and the SM045 is 40 lbs. When smoking ribs, the SM025 can hold 16 lbs. and the SM045 can hold 24 lbs.

- Keep meat approximately 1" from all oven walls at all times.
- Load less meat on the bottom grill to ensure meat on top grill is fully cooked.
- Close door and latch securely.

Do not overload your smoker. We recommend that on your first smoke you only fill your smoker half full and monitor periodically until you have a better idea of how long it will take to cook the meat properly.

To unload your smoker:

1. Turn smoker dial to the off position and let cool for 10 minutes.
2. Inspect the product and choose one of the following three options.
 - If the product is not done to your satisfaction then return the dial back to the on position and continue to smoke-cook.
 - If the product is done but you are not ready to eat, manually set your dial to a hold temperature.
 - If the product is done and you are ready to eat move on to step #3.
3. Carefully remove meat; the oven and meat will still be hot so use oven mitts that will completely protect you from being burned.

Shutdown Procedure

To properly shutdown your smoker:

1. Press the ON/OFF button and unplug smoker from the outlet.
2. Allow oven to cool.
3. After allowing the oven to cool, carefully remove the wood box from the oven and douse the contents with water.

Failure to follow the shutdown procedure instructions may result in a fire hazard!

Cleanup

ALWAYS DISCONNECT THE OVEN FROM ITS ELECTRICAL SUPPLY BEFORE CLEANING OR SERVICING.

1. Disconnect oven from power supply.
2. Allow the oven to cool.
3. Remove the grills and racks; Scrape and wash with soap and water (the racks and grills can go into the dishwasher however, do not use any caustic oven cleaners as they will destroy the plating on the grills).
4. Remove wood and ash remnants by discarding the aluminum foil covering (douse wood with water before discarding).
5. Remove all grease from interior of oven, using paper towel or cloths (once again, do not use caustic cleaners on the inside of smoker as this will damage the heating element).
6. Empty or remove drippings and replace drip pan.
7. Scrape loose grease and scale from walls with a flat edge scraper.
8. Replace racks and grills.

The bottom of your smoker must be kept clean. Change foil in bottom of oven and from top of wood box after each cook and remove all excess grease from interior of oven. Be sure the drain hole is open at all times. If drain becomes plugged, oven bottom can fill with grease and a fire hazard may occur.

Maintenance

Periodically check electrical plug and wire for any type of wear or damage.

Twice annually put two drops of lightweight oil on the hinge pins and latch pins to prevent binding.

Check casters for free movement.

Two Year Limited Warranty

Cookshack Smoker Ovens are guaranteed to be free from defects in material and workmanship under normal use and when installed in accordance with factory recommendations.

This warranty includes (2) two years on parts only.

Cookshack, Inc.'s obligation under this warranty shall be to repair or replace at its option any part deemed defective upon examination by Cookshack, Inc., or its authorized agent, for a period of two (2) years from the date of sale.

- The Limited Warranty extends to the original purchaser only.
- To make claim or request for the Limited Warranty, the original purchaser must notify Cookshack, Inc. Customer Service for instructions as to the repair or replacement of the defective merchandise prior to attempting or contracting for repair of the oven. (See following page for Return Merchandise Policies).
- The model number and serial number of the Cookshack Smoker Oven must accompany any request for service to the oven.
- The Limited Warranty shall not apply if the merchandise has been improperly installed, damaged due to abuse, misuse, misapplication, accident, or as a result of service or modification by any other than an authorized Cookshack, Inc. service agent.
- **The Limited Warranty is for Household Use Only. Warranty does not apply if used in a commercial setting.**

There are no express warranties other than the limited warranty stated herein above. No warranties whether express or implied, including, but not limited to, any implied warranties of merchantability of fitness for a particular purpose, shall extend beyond the respective warranty periods described above.

Cookshack, Inc. shall not be liable for any direct, indirect, special, consequential, incidental, or punitive damages; lost profits or loss of use or interruption of business regardless of the form of action or theory of liability resulting from any defect in or use of the Cookshack smoker oven, accessories and/or heating elements.

Additional information on obtaining service under this Limited Warranty is available on the following page or by contacting a Cookshack, Inc. Customer Service Representative directly at (800)423-0698.

Return Merchandise Policy

If you have merchandise that you believe is defective and requires repair or replacement:

1. Call Cookshack, Inc. at (800)423-0698. Ask to speak to a Customer Service Representative. Have your Smoker Oven model number and serial number ready.

If you are advised to return the merchandise to the factory for repair or replacement, please observe the following procedures.

2. You will be issued a return number. A Customer Service Representative will issue you a return number and/or mail you an instruction form (called a Return Merchandise Authorization) for returning the merchandise with the return number on it.

All return merchandise must have a return number. Do not return merchandise without a return number.

3. Attach the return number to the merchandise.

If you were sent a Return Merchandise Authorization, attach it to the merchandise you are returning.

If you were issued an RETURN NUMBER by phone and not sent a Return Merchandise Authorization, attach a note to the merchandise with your name, address and RETURN NUMBER.

Print the RETURN NUMBER on the outside of the return packaging.

4. Ship the merchandise back to Cookshack.

Return the merchandise to Cookshack, Inc., shipping prepaid, F.O.B. destination, in the original container or equivalent.

All return merchandise must be shipped to: Cookshack, Inc., 2405 Sykes Blvd., Ponca City, OK, 74601.

You assume the risk of any loss or damage that occurs during transit due to improper packaging of the returned merchandise. Use the original container that the merchandise was shipped in or equivalent.

5. Repair or replacement of merchandise under warranty.

Replacement or repairing defective merchandise is at Cookshack, Inc.'s option.

If repair of merchandise is deemed necessary by Cookshack, Inc. you will be instructed as to the necessary arrangements in order to affect the repair of the merchandise.

If replacement merchandise is deemed necessary by Cookshack, Inc. you will be invoiced for the replacement merchandise upon shipment. Credit for merchandise under warranty deemed to be defective by Cookshack, Inc. will be issued upon return of the defective merchandise.

Credit may be denied if the returned merchandise is not found to be defective by Cookshack, Inc.; if it is not under warranty; if it is not received at Cookshack, Inc. 30 days after your RETURN NUMBER is issued; if it is damaged due to abuse, misuse, misapplication or accident; if it has been serviced or modified by any other than an authorized Cookshack, Inc. service agent; is not returned with an RETURN NUMBER; is not in clean condition; is not complete; is damaged or lost in transit.

Replacement merchandise is sent to you via FedEx Ground or common carrier. If you request replacement merchandise to be sent by faster service than FedEx Ground or common carrier you shall incur the cost of shipping.

Material Damages:

Cookshack takes every precaution to use materials that retard rust. However, material can still be damaged by various substances and conditions beyond our control. For example, temperatures, excessive humidity, chlorine, industrial fumes, fertilizers, lawn pesticides, and salt are just some of the items that can affect metal coatings. This being stated, the Limited Warranty DOES NOT COVER RUST OR OXIDATION, unless there is a loss of structural integrity on the smoker. Cookshack recommends you purchase a Cookshack full length protective cover for your grill when not in use.

SM025/SM045 Common Parts List

Not Shown:

PV703: Drain Pan (not shown)

PV530: Universal Meat Probe

PV429: Meat Probe Jack
(Only needed if your smoker has an RCA style plug)

PV554: Control Panel

PM030: Side Racks

PV003: Grills (2)

PV003SS: Stainless Steel Grills (optional)

Latch

PV159: SM025

PV169: SM045

PA019: Wood Box

PV306: Element

PV161: Casters with Brake (4)

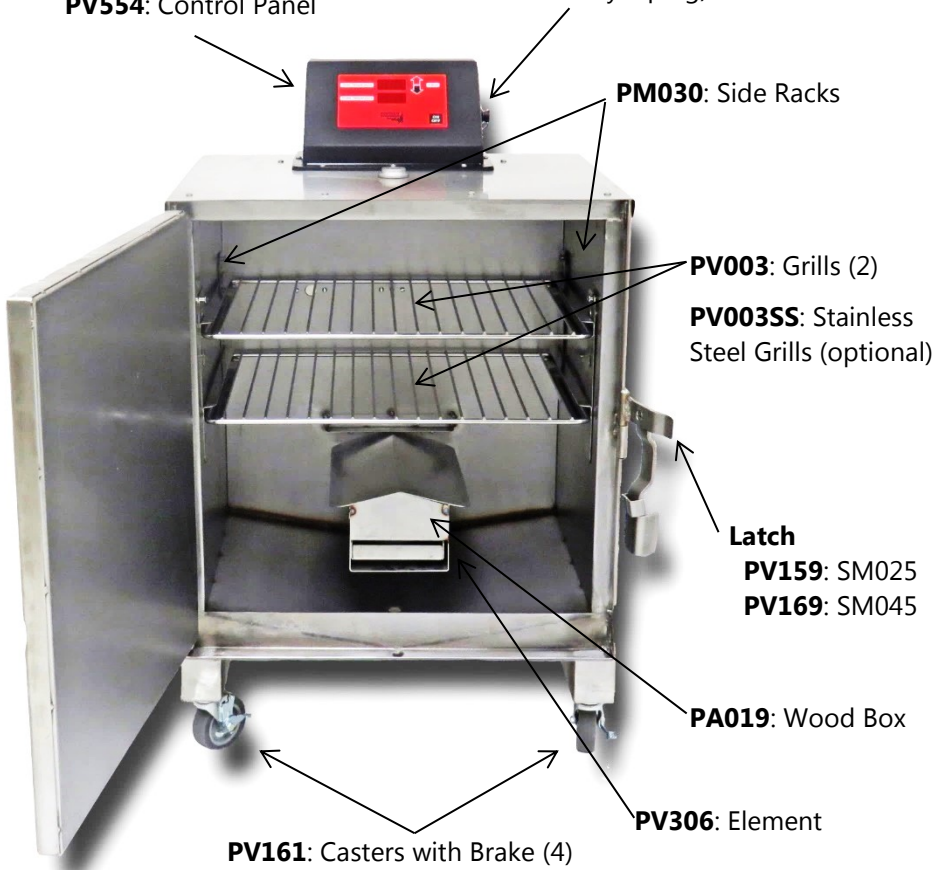

SM025 Wiring Diagram

03/08/18

SM-025 120 VOLT WIRING DIAGRAM

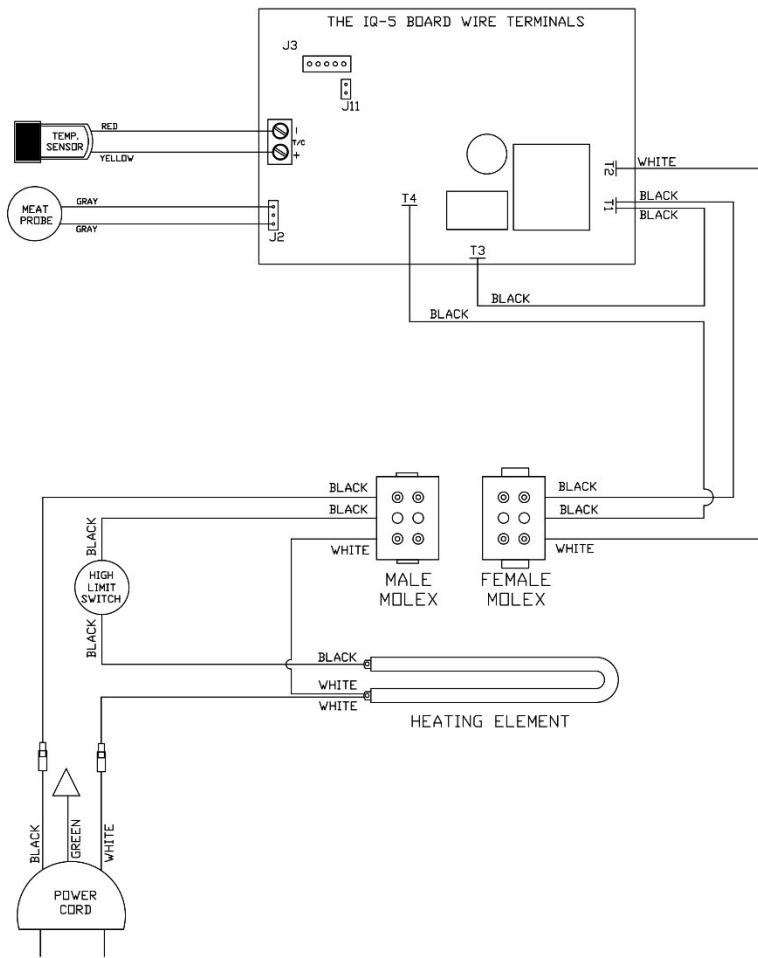

SM025 (240V Export) Wiring Diagram

03/19/18

SM-025 240 VOLT OVERSEAS WIRING DIAGRAM

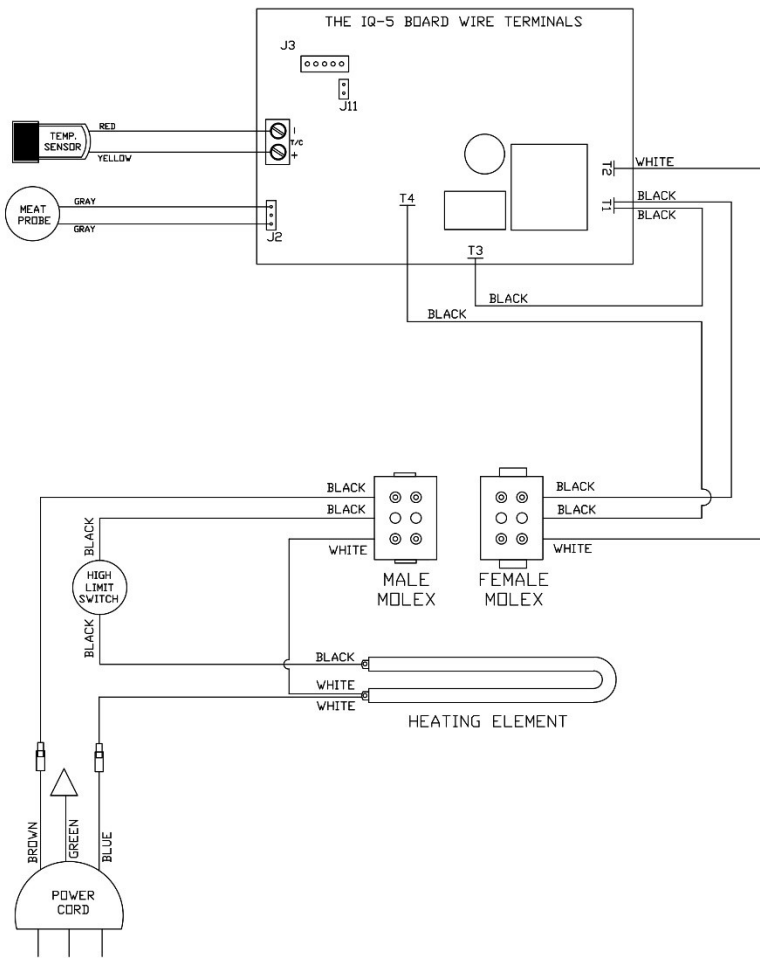

SM045 Wiring Diagram

03/08/18

SM-045 120 VOLT WIRING DIAGRAM

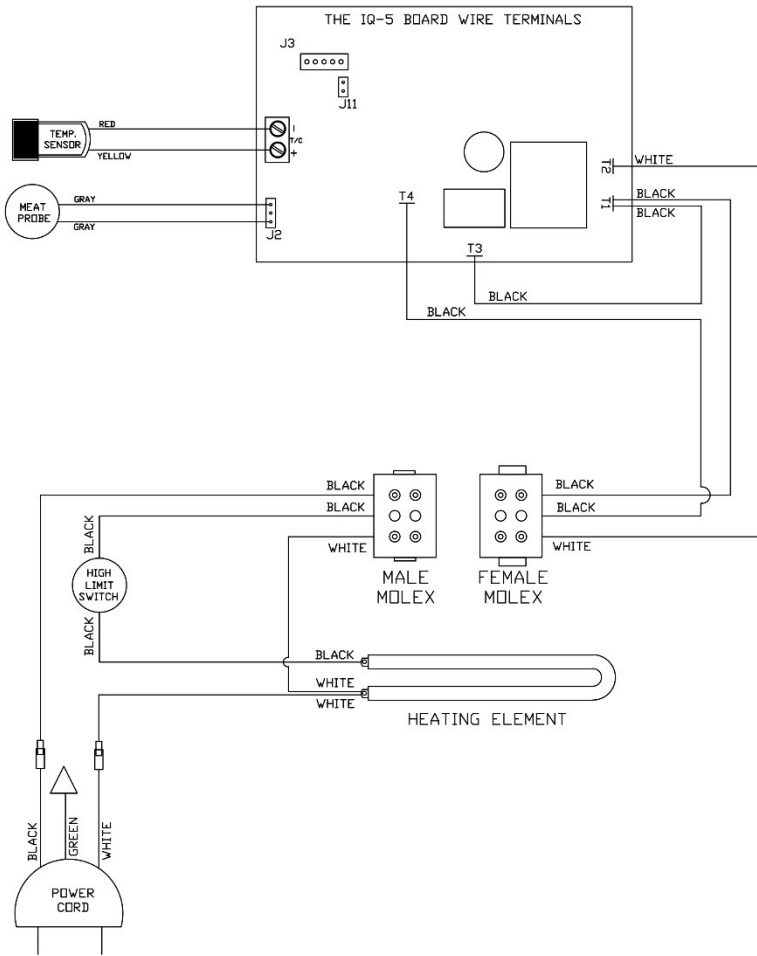

SM045 (240V Export) Wiring Diagram

03/19/18

SM-045 240 VOLT OVERSEAS WIRING DIAGRAM

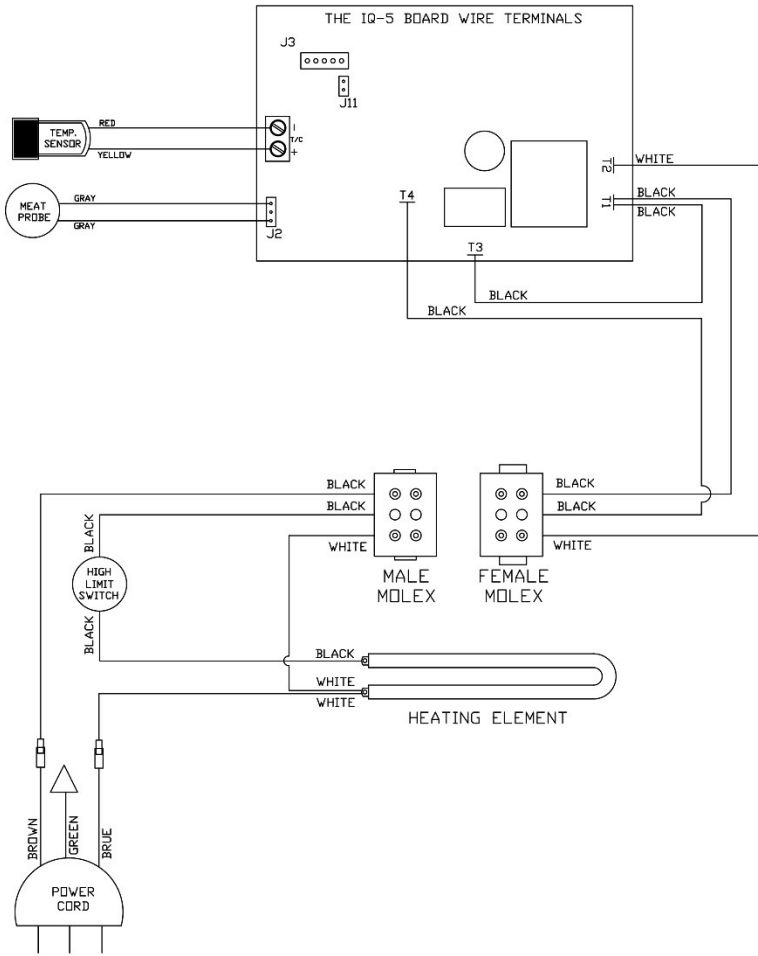



We are here for you!

From unboxing to cooking questions or tech support, we are here to help you every step of the way to becoming the best cook you can be.

Call or click today:

800.423.0698 | 580.765.3669

www.cookshack.com | forum.cookshack.com

or check us out on social media:

