

This Owner's Manual is provided and hosted by [Appliance Factory Parts](#).



GENERAL GA50A14 Owner's Manual

[Shop genuine replacement parts for GENERAL
GA50A14](#)



Appliance Factory Parts
© <http://www.appliancefactoryparts.com>

[Find Your GENERAL Air Cleaner Parts - Select From 69 Models](#)

----- Manual continues below -----



OWNER'S MANUAL

MODELS GA50A14, GA50A22, GA50A20 ELECTRONIC AIR CLEANERS

IMPORTANT: PLEASE READ MANUAL BEFORE OPERATING UNIT

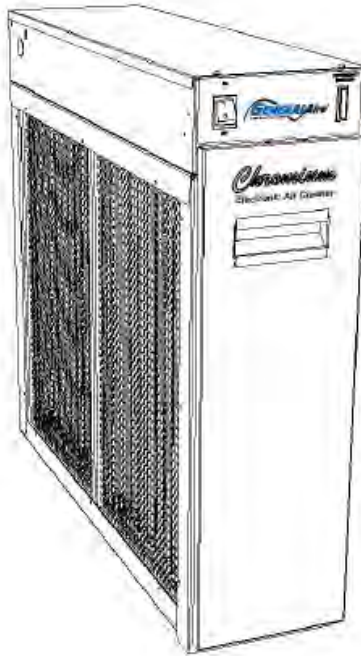

Features

- Lifetime Filter System never needs replacing
- Electronically removes dust, mites, pollen, pet dander, tobacco smoke, cooking smoke and grease, mold, fungi, bacteria, viruses and more, down to 0.01 micron
- Light Weight Aluminum Collecting Cells are durable and easy to maintain
- Cell Guide ensures proper placement of collecting cells
- Activated Carbon Filters remove unpleasant odors
- Electronic Air Proving Switch for quick wiring
- Dual Indicator Lights show Air Cleaner is working at a glance
- Galvanized Steel Cabinet for solid vertical or horizontal installation
- Durable Scratch-Resistant powder coat paint finish resists corrosion

IMPORTANT: Please read entire instructions before installing the Electronic Air Cleaner.

CONTENTS

SAFETY CONSIDERATIONS	2
WHAT THE ELECTRONIC AIR CLEANER DOES	2
BENEFITS	2
HOW IT WORKS	2
SPECIFICATIONS	3
COMPONENTS	3
INSTALLATION	3-5
Static Pressure	3
Location	3
Installation Location With Humidifier	4
Installation Location With Air Conditioner	4
Electronic Air Cleaner Installation	5
Wiring	5
SYSTEM CHECK	5
OPERATION	6
WHITE DUST	6
MAINTENANCE	6
Cell and Prefilter Cleaning	6
Activated Carbon Filter Replacement	6
SERVICE	7-10
Quick Check	7
Testing For High Voltage At Power Board	7
Measuring High Voltage At Power Board	7
Replacing Performance Light	7
Replacing A Power Board	8
Testing Air Proving Switch (APS)	8
Replacing An Air Proving Switch (APS)	8
Testing The 24 V Transformer	8
Replacing The 24 V Transformer	8
Setting Voltage Of Power Board	9
Setting Voltage Without High Voltage Meter	9
Testing For Voltage At The Cell	9
Testing Cell For Bad Contacts	9
Testing Cell with an Ohmmeter	9
Removing Power Box	10
Replacing A Tungsten Ionizing Wire	10
EXPLODED VIEW	10
PARTS LIST	11
TROUBLESHOOTING GUIDE	12
WARRANTY	15

WARNING

Before beginning any installation or modification, be certain that the main line electrical disconnect switch is in **OFF** position. Electric shock could result. Tag disconnect switch with suitable warning labels.

Installation and servicing of Electronic Air Cleaners can be hazardous. Only trained and qualified service personnel should install, repair, or service Electronic Air Cleaners.

Homeowners or untrained personnel can perform the basic maintenance functions of cleaning and replacing filters.

When working on air cleaning equipment, observe precautions in the manual, labels attached to the unit, and other safety precautions that may apply. Follow all safety codes. Wear safety glasses and work gloves.

WHAT THE ELECTRONIC AIR CLEANER DOES

Your High Efficiency Electronic Air Cleaner has been designed to remove atmospheric and household dust, coal dust, insecticide dust, mites, pollen, mold spores, fungi, bacteria, viruses, pet dander, cooking smoke and grease, tobacco smoke particles, and more down to .01 micron (.01 micron = 1/2,540,000 of an inch).

BENEFITS

- Helps provide relief for allergy or asthma suffering.
- Helps prevent damaging black dust from staining walls and furnishings, reducing the amount of time and money spent cleaning and redecorating.
- Helps eliminate unpleasant odors (with use of optional Carbon Filters).
- Helps protect heating/cooling equipment, prolonging the operating efficiency.

HOW IT WORKS

The High Efficiency Electronic Air Cleaner operates on the principle of electrostatic precipitation. Millions of airborne pollutants are carried through the return air ducts of the heating/cooling system and treated through four stages of filtration.

The *prefilters* (2) remove all large visible particles such as lint. Smaller particles then pass through a *two-stage electrostatic collecting cell* (2). First, particles are given a powerful positive electrical charge by the ionizing wires. Second, charged particles move into the collecting area

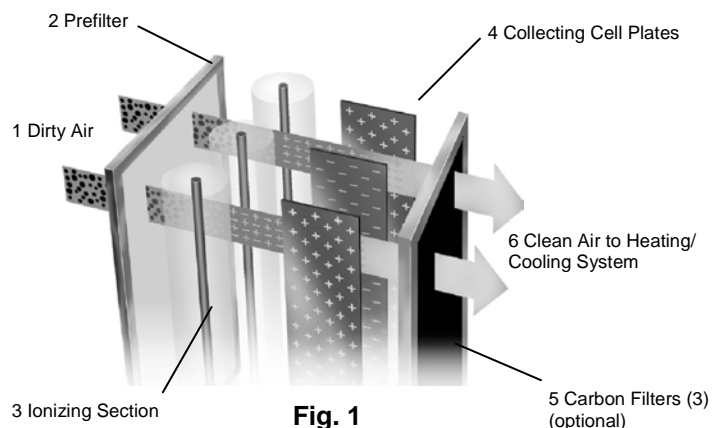

Fig. 1

Certified for shock and electrical fire hazard only.

SAFETY CONSIDERATIONS

Read and follow instructions carefully. Follow all local electrical codes during installation. All wiring must conform to local and national electrical codes. Improper wiring or installation may damage Air Cleaner.

Understand the signal words **WARNING** and **CAUTION** which are present in the Owner's Manual.

WARNING and **CAUTION** signifies a hazard which could result in property damage, personal injury or death.

Table 1 — SPECIFICATIONS

MODEL	GA50A14	GA50A22	GA50A20
House Size Area	<3000 ft ² <278.70 m ²	<3000 ft ² <278.70 m ²	>3000 ft ² >278.70 m ²
Airflow	up to 1400 CFM up to 2380 m ³ /hr	up to 1400 CFM up to 2380 m ³ /hr	up to 2000 CFM up to 3400 m ³ /hr
Duct Size	16 x 25 in 40.5 x 63.5 cm	20 x 20 in 51.0 x 51.0 cm	20 x 25 in 51.0 x 63.5 cm
Unit Weight	37 lbs 16.8 kg	37 lbs 16.8 kg	41 lbs 18.6 kg
Input Voltage	120 V 60 Hz	120 V 60 Hz	120 V 60 Hz
Power Consumption	30 Watts	30 Watts	30 Watts
Options Included	Carbon Filters Air Switch	Carbon Filters Air Switch	Carbon Filters Air Switch

where they are attracted to a series of grounded plates. Pollutants are held in this section like a magnet until washed away during cleaning. Lastly, clean air passes over *activated carbon filters* (3) for odor removal.

The Electronic Air Cleaner, available in three models with air flow capacities of up to 1400 and 2000 CFM (2380 and 3400 m³/hr), is adaptable to all residential forced air heating or cooling systems.

COMPONENTS

Cabinet: Constructed of heavy gauge galvanized steel to resist corrosion and provide trouble-free installation. Holes are provided to facilitate mounting to the ductwork or air handling equipment.

Power Box: Removable. Contains the power switch, performance indicator light, safety interlock switch, high voltage power board, air proving switch and high voltage contacts.

The power board is uniquely equipped with a variable resistor (potentiometer) to adjust high voltage output. Output has been pre-set for optimum efficiency. As voltage varies in extreme conditions of dryness, humidity or proximity to hydro towers, raising or lowering potentiometer allows for proper voltage output.

Air Proving Switch (APS): Integrated. Automatically cycles Air Cleaner on and off with the system fan. The APS will detect airflow (fan on) and energize the Air

Cleaner.

Collecting Cells: Consist of an ionizing section and a plate section. The arrow on the cell must point toward the system fan.

Prefilters: Constructed of aluminum mesh, to prevent lint and large particles from entering the collecting cells.

Carbon Filters: Remove odors. Must be replaced every six months - not washable. Maximum of (3) carbon filters can be used at same time.

INSTALLATION

Static Pressure

The static pressure drop across the Air Cleaner will vary with CFM and whether the optional carbon filters have been installed in the unit.

100% Air Flow No Carbon	100% Air Flow With Carbon	40% Air Flow No Carbon	40% Air Flow With Carbon
0.158	0.250	0.030	0.060

Table 2 — Pressure Drop (Inches WC)

Location

The Air Cleaner must only be installed in the return air duct, as close to the fan compartment as possible. This location provides the most even airflow across the collecting cells and allows the Air Cleaner to keep the system motor and blower clean. The installation can be vertical or horizontal. When choosing a location, there must be adequate room to wire the Air Cleaner and remove prefilters, collecting cells and power box for maintenance.

Note: Once Air Cleaner has been installed, do not allow the placement of any device such as a new hot water heater, water softener, gas pipe, or electrical cable to be put 2 ft. in front of or within 6 in. (15 cm) from top of Air Cleaner, in order to allow removal of filters and Air Cleaner parts, which are necessary for maintenance or servicing.

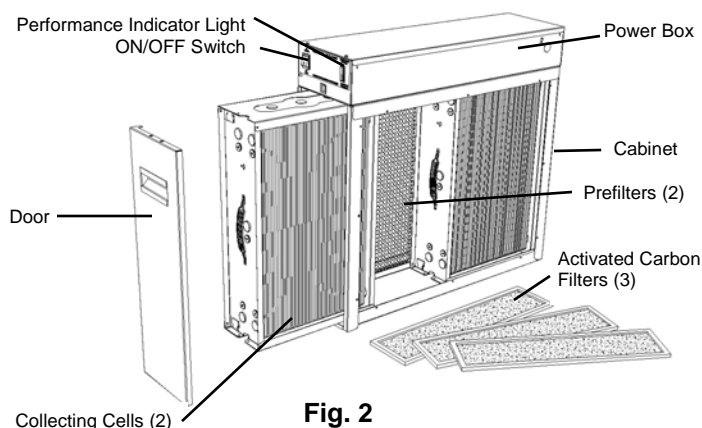
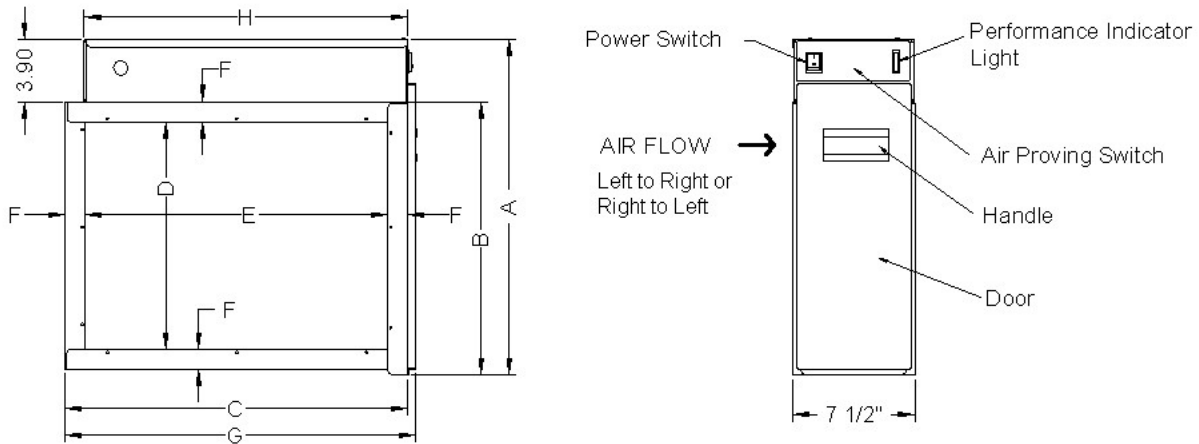

Fig. 2

Fig. 3 — DIMENSIONS



MODEL	DIMENSIONS — in (cm)							
	A	B	C	D	E	F	G	H
GA50A14	19.8 (50.4)	15.9 (40.5)	26.1 (66.3)	13.6 (34.6)	24.1 (61.2)	1.0 (2.5)	26.6 (67.7)	25.8 (65.4)
GA50A22	24.7 (62.8)	20.8 (52.9)	21.2 (53.9)	18.0 (45.7)	18.7 (47.5)	1.3 (3.2)	21.7 (55.2)	21.2 (53.9)
GA50A20	24.7 (62.8)	20.8 (52.9)	25.8 (65.4)	18.0 (45.7)	23.3 (59.1)	1.3 (3.2)	26.3 (66.8)	25.8 (65.4)

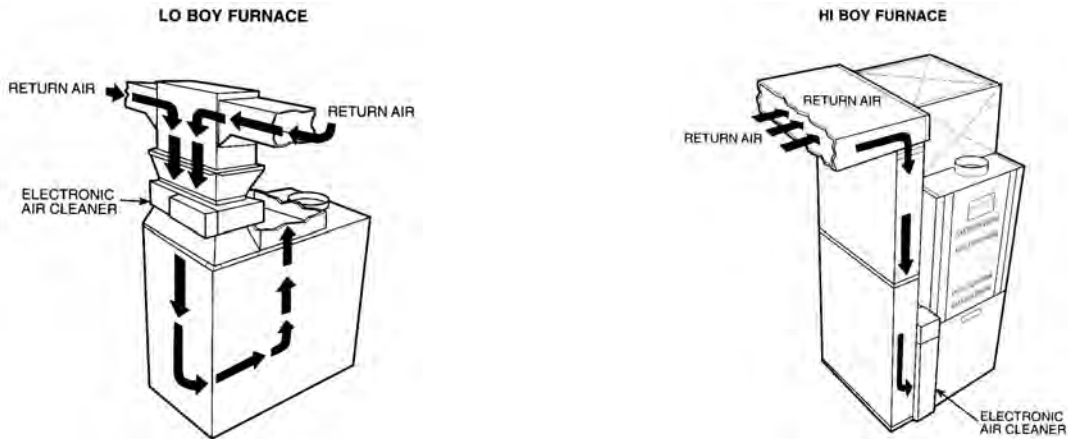

Fig. 4 — AIR CLEANER INSTALLATION LOCATION

Allow 24 in (600 mm) clearance for cleaning air cleaner. Allow 6 in. (150 mm) clearance for power box removal.

Installation Location With Humidifier

A humidifier should be installed in the furnace warm air duct. However, it may be installed in the return duct without causing problems to the Air Cleaner. Care must be taken to ensure that the humidifier does not leak, as this may cause arcing and a mineral deposit to build up on the collecting cells.

An atomizing type humidifier should be installed downstream from the Air Cleaner. If the atomizing type humidifier is installed upstream, high humidity, salts and minerals may decrease the efficiency of the collecting cells and cause service problems.

If the atomizing type humidifier must be installed upstream, the following precautions should be taken:

1. Atomizing type humidifier must be installed as far from the Air Cleaner as possible.
2. Collecting cells must be washed frequently to prevent a mineral deposit build-up.

Installation Location With Air Conditioner

Whenever possible, the Air Cleaner should be installed upstream of the cooling coil. This location will clean the air before it reaches the evaporator coil.

Electronic Air Cleaner Installation

1. Remove existing equipment filter. Thoroughly clean fan compartment and ductwork where Air Cleaner is to be installed.
2. Open access door. Slide filters and collecting cells out of cabinet.
3. Place cabinet in ductwork. Holes are provided to attach cabinet to ductwork or equipment. If the adjoining ductwork is flanged, install the screws so that the screw heads are inside the cabinet. This will help prevent damage to prefilter and carbon filters during removal for cleaning. **Never** put screws or rivets into the removable power box. When the air duct does not fit the Air Cleaner opening, a gradual transition is recommended to reduce air turbulence though the air Air Cleaner and to increase its efficiency. There should not be more than 20° of expansion used on each side of the transition fitting. Do not reduce ductwork to a smaller Air Cleaner or it will increase the velocity of airflow.
4. If the Air Cleaner is installed adjacent to an elbow or angle fitting, turning vanes are recommended to improve air distribution across the collecting cells.
5. After the Air Cleaner has been installed, seal seams airtight with duct tape or caulking to prevent dust from entering the system.
6. Replace the prefilters in the track on the air entering side. Place the carbon filters evenly spaced in the track on the air exiting side. The collecting cells are placed between the tracks, with the arrow on cell pointing towards the fan. The cell handle may need to be repositioned if the airflow is in a different direction than the left to right set up. The handle should face the door. Close access door.

Wiring

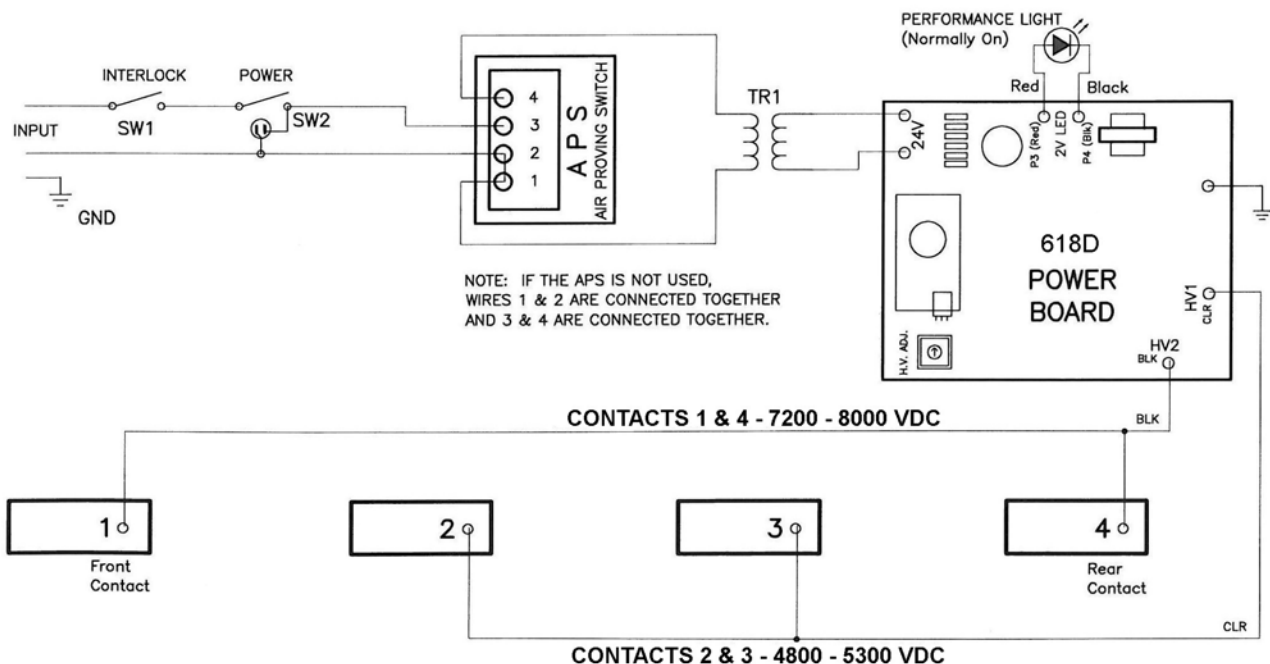

Fig. 5 — Air Cleaner Schematic (with Air Proving Switch)

WARNING

Electrical shock can cause injury or death. Be certain main line disconnect switch is off before wiring.

Wiring should only be performed by qualified personnel only. All wiring must comply with all applicable codes and standards. The voltage of the power source must match the voltage indicated on the Air Cleaner. The Air Cleaner must operate **ONLY** when the system fan is running. Make sure the Air Cleaner is properly grounded.

If the air cleaner is equipped with a cord and plug the air cleaner can be plugged into an outlet within 6 feet of the unit. Do not use an extension cord if the outlet is too far away. Have an electrician wire in a new outlet closer to the air cleaner.

If the air cleaner is not equipped with a cord then wire the Air Cleaner directly to a 120 V power source preferably to the same source that is supplying power to the furnace or air handler. The APS will power the Air Cleaner when there is sufficient airflow to activate the sensor. See Fig 5.

Note: The power switch will be lit even if there is no airflow.

If the unit is to be wired to the EAC contacts on the system module check that there is sufficient voltage to the EAC contacts with the fan operating in all conditions. Some systems do not power the contacts on low speed.

SYSTEM CHECK

Perform the following system check before operation.

1. Replace prefilters, collecting cells and carbon filters. Close access door.
2. Turn Air Cleaner power switch ON. Ensure system fan is operating. Both the power switch light and performance indicator light should be lit. The power switch light indicates the Air Cleaner has unit voltage. The performance indicator light shows that the Air Cleaner is operating.

Note: There may be some arcing or snapping sounds from the collecting cells. This is normal when the unit is new. In about 2 weeks, as the sharp edges of the cells become smoother, the arcing will disappear.

OPERATION

The Air Cleaner will run as long as there is adequate airflow through the ducts. The Air Cleaner will not run if the system fan is off. For proper operation, follow these simple steps:

1. Run heating/cooling system fan continuously, and on low speed if available.
2. Remove furniture or carpets which block return air grilles throughout your house, so that air moves freely to the furnace/ air conditioner.
3. Check for proper operation of the system fan.

WHITE DUST

After installation of the Air Cleaner, you may notice some white dust on tabletops and shelves. Most large particles such as lint, are too heavy to remain airborne and tend to settle quickly, never reaching the air cleaner.

This white visible dust is normally referred to as "clean dust." As the Air Cleaner is removing the dark and staining particles from the air, the lint will also be cleaner.

Lint dust is most noticeable on dark furnishings; in homes containing new carpeting; and where there is a lot of household traffic from occupants and pets. To reduce lint dust, use continuous fan operation and keep return vents unrestricted to create an efficient airflow.

Note: The Air Cleaner does NOT produce more lint or dust.

MAINTENANCE

It is important to follow a scheduled maintenance for maximum performance of the Air Cleaner.

CAUTION

Make sure to turn Air Cleaner and system fan **OFF** before performing any maintenance or removing any components.

Cell And Prefilter Cleaning

The collecting cells and prefilters must be cleaned on a regular basis for the Air Cleaner to function at its peak of efficiency. The frequency of cleaning will vary from one house to another. On average, the cells should be cleaned every 3 months.

1. Remove access door, collecting cells and prefilters.
2. Place cells in a laundry tub. Rinse with hot water and spray completely with DAX Detergent (or a non-chlorine, non-corrosive, non-abrasive liquid household detergent). Allow detergent to run down both sides of plates and ionizing wires. Let stand for 5 minutes or fill up laundry tub with water and DAX Detergent, and dunk cells up and down until water is dirty.

3. Rinse cells well with hot water (maximum 120°F/49° C).
4. To remove contaminate from the ionizing wires use an old toothbrush. Slide the brush bristles over the wire and gently drag the brush up and down the wire once. Be very careful when cleaning the wires as they become very brittle with age.
5. If dirt remains on the cell plates, let the cells soak in a solution of DAX Detergent and water for 30 minutes.
6. Tilt cells on 45° angle on their short side, with arrows pointing sideways. Allow to dry completely, approximately 8-10 hours. A hair dryer may be used to speed up drying time.
7. To wash prefilters, spray with DAX Detergent, rinse and let dry. Do not wash in the same water as collecting cells.
8. **Do not place the cells in the air cleaner if they are wet.**
9. Place cells and prefilters back into cabinet. Close door and turn power switch ON. If the performance light does not come on or arcing occurs, turn Air Cleaner OFF and allow air from system fan to dry cells completely.

CAUTION

Damage to cells may occur if improperly handled or washed. Do not wash cells in a dishwasher. Never use any object to clean between the cell plates, as this may cause damage to plates or ionizing wires. Never place cell in oven to dry. The edges of the cell may be sharp - handle with care.

Activated Carbon Filter Replacement

Carbon filters help remove odors from the air. If the Air Cleaner has been equipped with optional carbon filters, they should be replaced every 3 - 6 months. Filters are NOT washable. Replacements are available through



Fig. 6 — DAX Detergent and Carbon Filters are

DAX	32 oz Spray Bottle	Part #9900
Replacement Carbon Filters:		
GA50A14	Set of 3	Part #EAC14-12
GA50A20, GA50A22	Set of 3	Part #EAC20-12

your installer or dealer. To replace filters, perform the following functions:

1. Turn Air Cleaner power switch **OFF**.
2. Turn off system fan.
3. Open access door.
4. Remove collecting cells from Air Cleaner.
5. Remove the used carbon filters from Air Cleaner.
6. Put new carbon filters into Air Cleaner. Space filters evenly across the discharge opening of Air Cleaner. Never put more than 3 carbon filters in the Air Cleaner, as this may cause a problem with airflow.

SERVICE

WARNING

Electronic Air Cleaners use high voltage (low amperage). Only trained personnel should perform service. **USE CAUTION!** Electric shock can cause injury or death.

CAUTION

For most troubleshooting the cells should be removed from the Air Cleaner. A short in one of the cells will cause the power board to shutdown and the performance light will stay off. Unless otherwise directed remove the cells from the unit when testing.

The Air Cleaner when operating normally, with the fan running, should have both the switch light and the performance indicator light **ON**. If the fan is running and the lights are not on see the Troubleshooting Guide for probable causes and remedies.

WARNING

When performing LIVE tests in the power box **NEVER** touch any parts other than what are mentioned in the tests. Components carry dangerous voltages and extreme care must be taken.

Quick Check (Power Light ON, Performance Light OFF)

1. Make sure the **system fan is ON. Remove both cells.**
2. Close the door. If the light is still out, check the power board for an arc to ground at HV1 or HV2. If there is a good arc and no performance light then replace the light. If the light comes on check the cells for a fault.
3. If there is no arc, test the output voltage of the transformer. If there is transformer output replace the power board
4. If there is no transformer output, check for output of the APS.
5. If there is output from the APS replace the transformer and retest the power board for an arc.
6. If there is no output from the APS, jumper terminals 3 & 4 on the APS and retest the output. If there is

APS output with the jumper, replace the APS.

7. If there is no output from the APS check the output voltage from the on/off switch.
8. If there is no voltage from the switch, test the input to the switch. If there is input replace the switch. If there is no input to the switch check the interlock switch and the supply voltage.

Testing For High Voltage At Power Board

With the **collecting cells out of the unit**, the door on the unit and the system fan on high speed, turn the Air Cleaner **ON**.

With a long shafted screwdriver, with a plastic handle, short between the grounded side of the power box and the HV1 terminal of the power board.

If you draw a good spark, there is high voltage from the power board.

Measuring High Voltage At Power Board

A high voltage meter capable of measuring up to 10,000 VDC is required to test the voltage.

1. The Air Cleaner should be **ON** with the cells installed, the door closed and the system fan running. The Air Cleaner should be on at least 5 minutes to allow voltage to stabilize. The cells and ionizing wires must be clean.
2. Remove the cover from power box.
3. Connect the ground of the high voltage meter to an unpainted surface in the power box.
4. Check terminals HV1 and HV2 on the power board to determine if voltage is present. See Table 3 for values..
5. If no voltage is present, remove both cells from the Air Cleaner and replace door.
 - a. Check the voltage at HV1 and HV2 again.
 - b. If voltage is present, the problem is with one of the cells or the wiring to the copper contacts.
 - c. With a flashlight, look into the cabinet to check condition of the copper contacts.
 - d. If the contacts are not bent, replace one cell and retest voltage. If cell is OK, test the other cell. If the problem is with a cell, see Troubleshooting Guide.
 - e. If there is no voltage with both cells removed, check the power board, APS and transformer to make sure that they are functioning correctly.
6. If there is voltage present, but the performance light does not come on, replace light.
7. High voltage can be adjusted with high voltage potentiometer if required. See Table 3.

Replacing A Performance Light

Before replacing the performance light, turn **OFF** power to the Air Cleaner at the source.

1. Remove the power box cover.
2. Disconnect the performance light wiring connected to the LED terminals on the power board. Carefully cut the wire ties from the wire bundle.

3. Push the light out through front of power box.
4. Push the new light into the power box.
5. Connect the wiring to the LED terminals on the power board. P3 - red; P4 - black. Route the wires away from the high voltage wires or contacts.
6. Replace cover.
7. Return power to Air Cleaner. Test light.

Replacing A Power Board

Before replacing the power board, turn **OFF** power to the Air Cleaner at the source or remove the plug.

1. Remove the power box cover.
2. Disconnect wiring from the LED, HV1, HV2 and 24 V terminals. Make note of position of wires.
3. Remove the three hex nuts from the power board.
4. Remove the power board from the studs.
5. Place the new board onto studs with the 24 volt input close to the transformer.
6. Replace the hex nuts removed in Step 3. Ensure the star washer is in place over the steel spacer at the ground location on the power board. For proper grounding the washer must be located on the top of the steel spacer, under the power board.
7. Reconnect wiring to LED, HV1, HV2, and 24 V terminals on the new power board. See Fig. 5.
8. Return power to Air Cleaner. Test power board.
9. Replace power box cover.

Note: The power board has been set before shipping. It is not usually necessary to reset the voltage to the new load. If you do need to adjust the voltage refer to Setting Voltage of Power Board section for more information.

Testing Air Proving Switch (APS)

The APS sensor must sit in the plastic bushing to operate correctly. The sensor is very sensitive and operation may be affected by cold ambient temperatures, an air exchanger, or a fresh air duct connected to the return air duct just upstream of the Air Cleaner.

The APS uses a Triac in its output circuit, which affects the voltage sine wave. Using a regular digital voltmeter may give a false reading. To check the output from the APS, use a true RMS (root mean square) meter to measure the output at terminals 1 and 4 of the APS. The output should be between 105 and 115 VAC, depending on the airflow across the sensor.

A 125 volt neon lamp may be used to test the output of the APS. Place the leads of the lamp across terminals 1 and 4 of the APS. If the lamp lights, the voltage is sufficient for operation. **Do not use performance light.**

When the Air Cleaner is turned on without airflow, the APS sensor heats up, and after 20-30 seconds opens the circuit to turn off the power board. When the fan starts up (the sensor is cooled), the circuit will close, the power board is turned on, and the performance light will come on.

The light on the power switch will be lit even when the APS is open.

If the power board fails to come on with the fan on, check that the sensor is properly set down, to the bottom of the plastic bushing, in the front of the power box. To check the APS for proper operation remove the collecting cells, turn the unit **ON** without the fan on. The power board should come on immediately, and then turn off in 20-30 seconds as the sensor heats up. To check sensor, blow directly on it lightly. This should activate the power board within 10 seconds. Service the sensor carefully. The sensor leads are 120 V. If the APS does not turn the power board and performance indicator on, by-pass the APS by placing a jumper between wires 3 & 4 on the APS. This removes the APS from the circuit.

See Troubleshooting Guide for more information.

Note: If the air flow through the Air Cleaner is less than 360 CFM the APS sensor may not have enough air flow to activate the Air Cleaner. See Wiring for information how to wire the Air Cleaner to the EAC module of the system. In very low air applications the Air Cleaner may need to be wired through the EAC contacts and the APS disabled by connecting wires 3 & 4 together.

If there is no EAC module or it is not powered on low speed then a relay will have to be installed to activate the Air Cleaner when the fan starts. The APS will have to be disabled.

Replacing An Air Proving Switch (APS)

Before replacing the APS, turn **OFF** the power to the Air Cleaner at the source.

1. Disconnect wiring from terminals 1, 2, 3, and 4 on the APS. See Fig. 5.
2. Remove the circuit board from the studs by removing the two nuts. Do not remove the spacers.
3. Install the new APS on the studs and secure with the nuts. Ensure sensor protrudes only to the bottom of the plastic bushing.
4. Connect wiring to terminals on APS. See Fig. 5. Wiring from the power switch is connected to terminals 2 and 3. Wiring to the transformer is connected to terminals 1 and 4.
5. Test the new APS.

Testing The 24 V Transformer

1. Remove power box cover.
2. Disconnect the leads of the 24 V transformer from the power board. See Fig. 5. Do not short leads.
3. The Air Cleaner should be **ON**. The system fan should be running on high speed. The access door should be closed.
4. Measure voltage across the leads with a voltmeter. Voltage should read 25 - 28 VAC.
5. If no voltage is present, check operation of the APS.
6. Reconnect leads to the power board.
7. Replace power box cover.

Replacing The 24 V Transformer

Before replacing the transformer, check the resistance across the power board 24 V input terminals,

without the transformer connected. Resistance should read above 20K ohms with an analog meter and above 4M ohms with a digital meter. If the resistance readings are below these values, the power board may be the cause of the transformer failure.

Before replacing the 24 V transformer, turn **OFF** power to the Air Cleaner at the source.

1. Remove power box cover.
2. Disconnect the secondary leads from the transformer to the 24 V terminals on the power board. See Fig. 5.
3. Cut the primary leads (to the APS) close to the transformer or disconnect leads from the APS.
4. Remove the 2 hex nuts and washers from the transformer studs.
5. Remove the transformer.
6. Place new transformer over studs and re-install 2 star washers and hex nuts to secure into place.
7. Connect secondary leads (white) to the 24 V terminals on the power board (P1 & P2).
8. Wire nut primary leads from APS (cut in Step 3) to the primary leads of the new transformer or connect primary leads to APS terminals 1 & 4.
9. Replace power box cover.
10. Turn **ON** the power to the Air Cleaner and test.

Setting Voltage Of Power Board

Voltage on the power board may drop below required level when installation area is too damp, too cold, or if there is a leakage of water from a humidifier. Voltage on power board may be too high when installation area is too dry or too hot, or home is in close proximity to hydro towers or situated in remote farm land areas. By adjusting the HV Adj. potentiometer, the voltage can be set to optimum level. A high voltage meter capable of measuring 10,000 VDC is required. To test and adjust voltage level, perform the following procedure:

1. Turn the Air Cleaner **OFF**.
2. Remove the power box cover.
3. Connect the ground of the high voltage meter to an unpainted surface in the power box.
4. Turn **ON** the Air Cleaner and wait 5 minutes before checking voltages to allow voltages on cells to stabilize. The cells and ionizing wires must be clean.
5. Measure the voltages at HV1 and HV2 on the power board.
6. Adjust the HV Adj. potentiometer until the voltage reading matches the voltage in Table 3. Adjusting the potentiometer **clockwise decreases** the voltage and turning **counter-clockwise increases** the voltage.
7. Turn **OFF** the Air Cleaner.

Model	Maximum Voltage on Plates (KVDC)	Maximum Voltage on Ionizer (KVDC)
GA50A14	4.8 - 5.3 (HV1)	7.2 - 8.0 (HV2)
GA50A20, GA50A22	4.8 - 5.2 (HV1)	7.2 - 7.8 (HV2)

Table 3 — Power Board Voltage Settings (with load)
The voltage will be higher without the cells in the unit.

8. Remove the high voltage meter.
9. Replace the power box cover.
10. Turn **ON** the Air Cleaner.

Setting Approximate Voltage Without High Voltage Meter

A high voltage meter should be used to set the high voltage. If one is not available, this method can be used. This will only set an approximate voltage. After using this method, the voltage should be reset with a high voltage meter as soon as possible.

1. Remove power box cover.
2. Turn the HV Adj. potentiometer fully counter-clockwise. The Air Cleaner may arc or snap at this point.
3. Turn the HV Adj. potentiometer back, clockwise, until the arrow is between 6 and 8 on the dial or on the + side of the half way point.
4. Replace power box cover.

Testing for Voltage At The Cell

1. Open access door to Air Cleaner.
2. The cells must be in the Air Cleaner for this test and the system fan should be on high speed.
3. Turn the Air Cleaner **ON** and press the safety interlock switch lever.
4. Place a plastic handled screwdriver into the direction arrow slot. Do not apply excessive force.
5. If there is a good snap then there is high voltage at the cell.

Testing Cell For Bad Contacts

1. Open access door to Air Cleaner.
2. The cells must be in the Air Cleaner for this test and the system fan should be on high speed.
3. Turn the Air Cleaner **ON** and press the safety interlock switch lever.
4. Place a plastic handled screwdriver into the direction arrow slot. Do not apply excessive force.
5. There should be an initial snap when the plates are shorted, then no sound. If a hissing occurs, then there is a bad contact. Look along the top of the cell, with the short still in place. If there is a small arc between the cell top and copper contact, then that is the bad contact. Pull cell out and gently pull the copper contact down.
6. If an arc is not seen and there is a bad contact, then the problem may be an internal contact in one of the cells.
7. Let up on safety interlock.
8. Close access door.

See below for additional testing.

Testing Cell with an Ohmmeter

To test the cell for a dead short or a bad contact an ohmmeter can be used. **Always discharge the cell with a screw driver before testing with an ohmmeter.**

1. With the ohmmeter set on its lowest scale take a reading between the top center contact of the cell and the ionizing fingers on the bottom of the cell. You should have continuity. If you do not then there is a bad contact between the center contact and the top set of ionizing fingers.
2. Test the resistance between the top center contact and the cell frame. You should read infinite resistance. If not you have a short in the ionizing section.
3. Take a reading between the two outside contacts on the top of the cell. You should have continuity. If you do not then there is a bad contact between one of the contacts to the live cell plate. Test each top outside contact to the last plate in the cell to determine which contact is not mating properly.
4. Test the resistance between the outside contacts and the cell frame. You should read infinite resistance. If not you have a short in the collecting section.
5. If you have a bad contact adjust the internal contacts within the cell until contact is made.

Removing Power Box

1. Turn the main system switch **OFF** or disconnect the power cord.
2. Remove the power box cover.
3. If the unit does not have a cord disconnect the source wires to the Air Cleaner. Cap off the wires so

the system can still be operated.

4. Remove the two nuts holding the power box to the cabinet.
5. Slide the power box forward then up to remove it from the cabinet.
6. If you are removing the power box for any length of time tape a cover over the top opening to prevent air from entering into the system.

Replacing A Tungsten Ionizing Wire

Replacement wires are cut to the correct length and have eyelets at each end for easy replacement.

1. Turn **OFF** power to Air Cleaner.
2. Remove cell from Air Cleaner.
3. Remove all parts of broken wire from the cell. If necessary, the cell may be used temporarily with one wire missing until a replacement is received.
4. Place one end of the loop over the finger at the bottom of the cell.
5. Using needle-nose pliers, grip the other end of wire, near the bottom of the top loop. Pull the wire up toward the top finger. As you apply tension, the bottom finger will give, allowing the placement of the loop around the top finger.
6. Install cell in Air Cleaner.
7. Return power to Air Cleaner.
8. Test cell for proper operation.

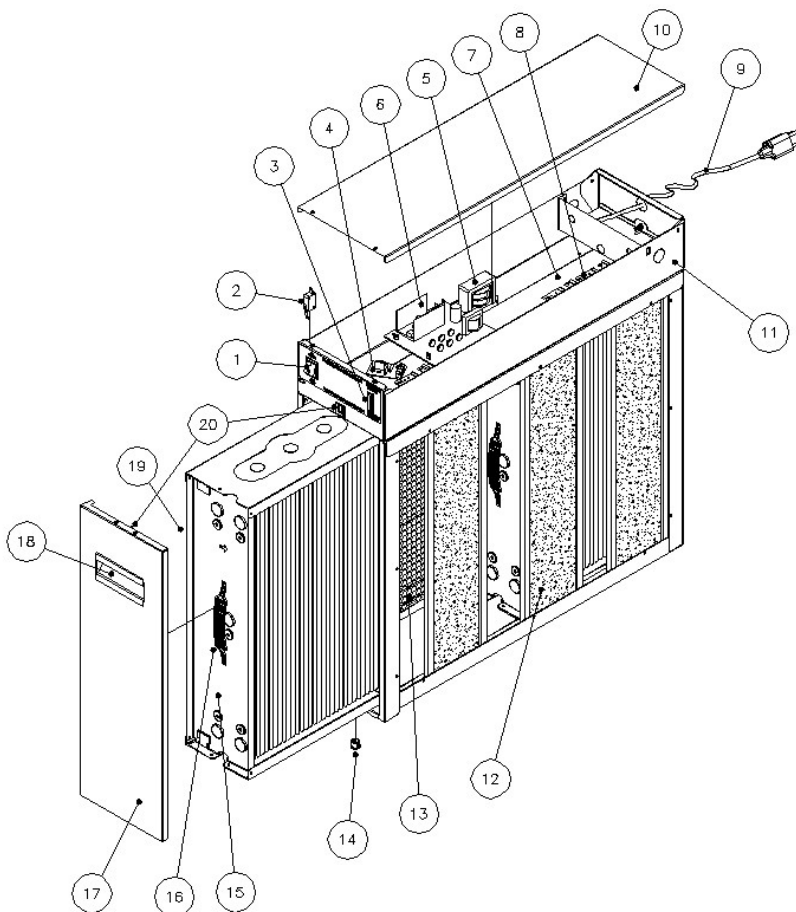

#	Part Description
1	On/Off Switch
2	Safety Interlock Switch
3	Performance Indicator Light (Green LED)
4	Air Proving Switch
5	24 Volt Transformer
6	Power Board
7	Fibreboard (with 4 Copper Contacts)
8	Copper Contact
9	Cord Assembly (Optional)
10	Cover for Power Box
11	Power Box Complete (No Cover)
12	Carbon Filters (Set of 3)
13	Prefilter
14	Cell Guide (Plastic)
15	Collecting Cell
16	Cell Handle
17	Door (with Plastic Clip & Handle)
18	Door Handle (Plastic)
19	Ionizing Wire
20	Male & Female Door Clip Set
21	Door Label (Important... Wait 15 Seconds)
22	Door Label (Cleaning Instructions)
23	Dax Detergent

Use Part Numbers When Ordering (See next page)

Fig. 7 — Exploded View

Parts List

Use the diagram on the preceding page to identify the part which is required. To order parts call the number listed at the bottom of the page or call your local contractor.

#	Part Description	Type 11A GA50A14	Type 12A GA50A22	Type 18A GA50A20
1	On/Off Switch	EAC14-01	EAC14-01	EAC14-01
2	Safety Interlock Switch	EAC14-02	EAC14-02	EAC14-02
3	Performance Indicator Light (Green LED)	EAC14-03	EAC14-03	EAC14-03
4	Air Proving Switch	EAC14-04	EAC14-04	EAC14-04
5	24 Volt Transformer	EAC14-05	EAC14-05	EAC14-05
6	Power Board	EAC14-06	EAC20-06	EAC20-06
7	Fibreboard (with 4 Copper Contacts)	EAC14-07	EAC22-07	EAC20-07
8	Copper Contact	EAC14-08	EAC14-08	EAC14-08
9	Cord Assembly (Optional)	EAC14-09	EAC14-09	EAC14-09
10	Cover for Power Box	EAC14-10	EAC22-10	EAC14-10
11	Power Box Complete (No Cover)	EAC14-11	EAC22-11	EAC20-11
12	Carbon Filters (Set of 3)	EAC14-12	EAC20-12	EAC20-12
13	Prefilter	EAC14-13	EAC22-13	EAC20-13
14	Cell Guide (Plastic)	EAC14-14	EAC14-14	EAC14-14
15	Collecting Cell	EAC14-15	EAC22-15	EAC20-15
16	Cell Handle	EAC14-16	EAC14-16	EAC14-16
17	Door (with Plastic Clip & Handle)	EAC14-17	EAC20-17	EAC20-17
18	Door Handle (Plastic)	EAC14-18	EAC14-18	EAC14-18
19	Ionizing Wire	EAC14-19	EAC20-19	EAC20-19
20	Male & Female Door Clip Set	EAC14-20	EAC14-20	EAC14-20
21	Door Label (Wait 15 Seconds...)	EAC14-21	EAC14-21	EAC14-21
22	Door Label (Cleaning Instructions)	EAC14-22	EAC14-22	EAC14-22
23	Dax Detergent	9900	9900	9900



General Filters, Inc.
 43800 Grand River Ave.
 Novi, Michigan 48375-1115
 WWW.GENERALAIre.COM
 1-866-476-5101
 248-476-5100

Canadian General Filters, Ltd.
 39 Crockford Blvd.
 Scarborough, Ontario
 WWW.CGFPRODUCTS.COM
 416-757-3691



Table 4 — TROUBLESHOOTING GUIDE

PROBLEM	PROBABLE CAUSE	REMEDY
Unit does not function correctly. Power light and performance indicator light are OFF.	System fan is not on.	Turn system fan on.
	Wiring improperly connected.	Check wiring or if plug is inserted and receptacle is powered.
	Defective power switch.	Check power switch for continuity with ohmmeter. Replace if defective.
	Defective safety interlock.	Remove door and press safety interlock with a screwdriver. If lights come on, bend interlock lever towards front and close door.
Unit does not function correctly. Power light is ON and performance indicator light is OFF.	Short in cells due to: 1. Broken ionizing wire. 2. Large particles wedged between cell plates. 3. Cells washed recently and are still wet. 4. Cell end plate insulator is dirty or damaged. 5. Cell plate(s) are bent.	1. Remove wire or wire fragments. Replace. 2. Shake large particles out or wash cell. 3. Allow cells to dry completely. 4. Clean or replace end plate insulator. 5. Straighten plates with pliers.
	Defective performance indicator light.	Determine whether high voltage is present by testing power board. If voltage is present, replace indicator light.
	Defective power board.	Adjust high voltage potentiometer on power board counter-clockwise. If high voltage is not present, replace power board.
	Air Proving Switch (APS) sensor is burnt out.	Remove power box lid and blow lightly for 10 seconds on APS sensor at bottom of power box. If light does not come on, replace APS.
	Air Proving Switch is not getting enough air across the sensor.	Check that sensor is located in the plastic bushing at the front of the power box. Check that the return duct is installed flush to the top and front edge of the Air Cleaner duct opening. Ensure there is a minimum of 360 CFM of air to the air cleaner.
	Off board 24V transformer is not working.	Verify output of transformer. Replace if necessary.
	Defective power switch.	Verify output of switch. Replace if necessary.
Power light is OFF and performance indicator light is ON.	Defective power switch light.	Replace power switch.
Cell makes loud hissing noise or causes radio interference.	Internal cell contacts are not touching plates.	Test contacts and repair.
	Copper contacts on high voltage tray not making good connection on cell.	With needle-nose pliers, gently pull contacts down or replace contacts.
Cells arcing excessively (power light and performance indicator light ON or flashing).	Cells wet from washing.	Allow cells to dry completely.
	Particles lodged in cell or broken ionizing wire.	Wash cell. Shake particle out of cell. Replace wire, if necessary.
	Ducts were not cleaned prior to installation of air cleaner.	Clean ducts.
	Cell plates are bent.	Remove cells and adjust to original spacing using needle-nose pliers.
	Dirty cells.	Wash cells and clean ionizing wires.
	Voltage is too high.	Adjust high voltage potentiometer on power board clockwise.
	High voltage wires are on wrong copper contact.	Reposition high voltage wires on proper contact (see Fig. 5).
	Internal contact on cell out of alignment.	Realign cell contact.
Humidifier (if installed) is leaking water on air cleaner.	Repair humidifier. If possible, move humidifier to different location.	
Cells arcing excessively at top of cell near copper contacts (power light and performance indicator light ON).	Copper contact on high voltage contact board are broken or bent upward.	If possible, pull down contacts with needle-nose pliers or remove power box and replace contacts.
Cells not collecting dirt (power light and performance indicator light ON).	Arrow on cells not pointing towards fan blower.	Reposition cell handle and place cell in properly.
	System fan is on "Automatic" setting (air cleaner not on continuously)	Use "Fan On" system fan setting for continuous fan operation.
	Not enough voltage on collecting cells.	Adjust high voltage potentiometer counter-clockwise on power board.
Ozone odor	Cell plates are bent.	Straighten with needle-nose pliers.
	Loose or broken ionizing wire.	Replace wires.
	Dirty cells.	Wash cells and clean ionizing wires.
	Air Cleaner is on when system fan is not running. Air cleaner wired incorrectly or air proving switch is defective.	Check operation and wiring of air switch and air cleaner.
	Incoming voltage is higher than 120V.	Adjust high voltage potentiometer clockwise on power board.
	Air Cleaner is oversized for house. Not enough airflow to cover surface area of cells.	Use correct size of Air Cleaner.
	Home is extremely dry.	Repair or install central humidifier.
White dust	Clean lint dust too heavy to remain airborne.	Keep fan running continuously. Ensure that return air grilles are not obstructed.
	Gaps around Air Cleaner.	Seal or use duct tape around Air Cleaner cabinet.

ELECTRONIC AIR CLEANER LIMITED FIVE YEAR WARRANTY

Electronic Air Cleaners, if properly registered by the return of the attached warranty registration to General Filters, Inc., are warranted to the consumer against defects in materials and workmanship for a period of five years from the date of installation, so long as the product has been installed and operated in accordance with all appropriate manuals and wiring diagrams. Replacement or routinely replaceable parts such as prefilters, ionizing wires or carbon filters, are not covered by this limited warranty or any other warranties. Any other defective parts will be repaired without charge except for removal, reinstallation and transportation costs. To obtain repair service under this limited warranty, the consumer must send the defective part to General Filters, Inc.

THERE ARE NOT EXPRESS WARRANTIES COVERING THIS ELECTRONIC AIR CLEANER OTHER THAN AS SET FORTH ABOVE. THE IMPLIED WARRANTIES OF MERCHANTABILITY AND FITNESS FOR A PARTICULAR PURPOSE ARE EXPRESSLY EXCLUDED. THE MANUFACTURER ASSUMES NO LIABILITY IN CONNECTION WITH THE INSTALLATION OR USE OF THIS PRODUCT, EXCEPT AS STATED IN THE LIMITED WARRANTY. THE MANUFACTURER WILL IN NO EVENT BE LIABLE FOR INCIDENTAL OR CONSEQUENTIAL DAMAGES.

This limited warranty gives you specific legal rights, and you may also have other rights which vary from state to state. Some states do not allow either limitations on implied warranties, or exclusions from incidental or consequential damages, so the above exclusion and limitation may not apply to you.

Any questions pertaining to this limited warranty should be addressed to General Filters, Inc. General Filters, Inc. has elected not to make available the informal dispute settlement mechanism which is specified in the Magnuson-Moss Warranty Act.

Agency:

Form 14520 Rev. G



General Filters, Inc.
43800 Grand River Ave.
Novi, Michigan 48375-1115
WWW.GENERALAIR.COM

Canadian General Filters, Ltd.
39 Crockford Blvd.
Scarborough, Ontario
WWW.CGFPRODUCTS.COM



Technical Support 1-800-267-8305



ATTENTION INSTALLER

IMPORTANT WIRING INFORMATION

This Electronic Air Cleaner is equipped with an Air Proving Switch (APS). The recommended source for the input voltage to the Air Cleaner is from the same source that is supplying the heating/cooling equipment, providing it is the same voltage as the Air Cleaner. The Air Cleaner should be wired directly to the power source. The APS will power the Air Cleaner when there is sufficient airflow to activate the sensor.

If you wish to wire the Air Cleaner to the EAC / Accessories Module on the circuit board of the furnace or air handler, ensure that there is 115 Volt output from these terminals, when the unit is run manually and is running on low speed. Some manufacturers do not supply full output voltage to the terminals in the low speed mode, so the Air Cleaner will not function. The green Performance Indicator Light will not turn on.

The Air Cleaner performs best when the system fan is on “FAN ON” or “Continuous” mode, and is run on the low speed. Check the output of the terminals with a volt meter when running on low speed, before wiring the Air Cleaner to the circuit board.

The Air Cleaner must be wired to operate only when the system fan is on.

See page 5 of the Owner’s Manual for more information on wiring.