

This Owner's Manual is provided and hosted by [Appliance Factory Parts](http://www.appliancefactoryparts.com).



# GENERAL 3018 Owner's Manual

[Shop genuine replacement parts for GENERAL 3018](#)



[Find Your GENERAL Air Cleaner Parts - Select From 69 Models](#)

----- Manual continues below -----

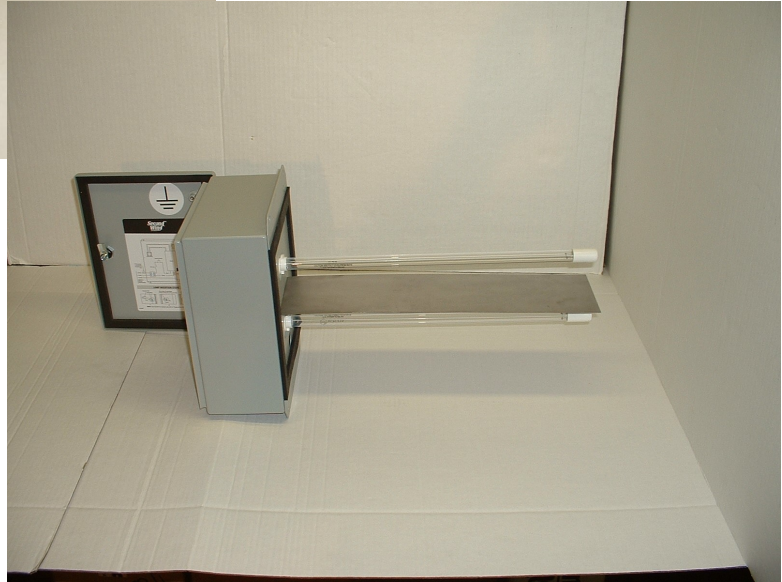

# **Second Wind NEMA Series Air Purifiers Installation & Maintenance Manual**

## **Models:**

**2000-2300D (GF# 4906)**

**3018 (GF# 4955)**

**3024 (GF# 4957)**

**3032 (GF# 4958)**

# SAFETY CONCERNS

Please read all instructions carefully to help ensure a correct and SAFE installation of your Second Wind Ultraviolet Germicidal Air Purifier. Failure to do so could damage the equipment or cause harm to yourself or others. Only qualified Heating Ventilation and Air Conditioning (HVAC) technicians should perform the installation.

## ***READ ALL WARNINGS AND CAUTIONS***

### **WARNING: FAILURE TO FOLLOW THESE RULES MAY RESULT IN SERIOUS PERSONAL INJURY**

- 1 Read instruction manual before operating the units.
- 2 Eye damage may result from directly viewing the light produced by these lamps. To reduce the risk of exposure to UV radiation, take UV-radiation protective measures for personnel during servicing.
- 3 This fixture is designed for use with germicidal UV-C lamps and must be installed in compliance with competent technical directions so that user's eyes and bare skin will not be subjected to injurious rays.
- 4 UV Light Hazard. To prevent exposure to ultraviolet light, be sure the ultraviolet air treatment system is disconnected before servicing any part of the HVAC system or removing any access panel or the equivalent.
- 5 There shall not be any openings in the duct that would emit light.
- 6 There shall not be any duct supply or return air openings or any other openings that are in direct line-of-sight of the UV bulb.
- 7 Check damaged parts: Before further use of the unit, any damaged part should be carefully checked to ensure that the unit will operate properly. Any part that is damaged should be properly repaired or replaced.

### **CAUTION:**

- 1 Personal Injury Hazard. Power supply can cause electrical shock. Disconnect power supply before servicing or beginning installation.
- 2 Risk of exposure to excessive ultraviolet (UV) radiation—Do not operate without complete lamp enclosure in place or if sight lens is damaged.
- 3 Equipment Damage Hazard. Ultraviolet light can cause color shift or surface degradation and sometimes structural degradation of non-metallic components. Select mounting location that prevents exposure to plastic flexible duct components, polyurethane foam insulation material, rubber hoses, wire insulations, etc. If mounting options are limited, items above should be protected with ultraviolet resistant materials such as aluminum foil, aluminum duct tape, or metallic shields.

### **INSTALLATION LOCATION:**

1. See page 4 for possible installation locations.
2. Products shall be mounted only on to metal air ducts.
3. Mounting shall be such that all surfaces in the duct where appliance forms parts of the duct shall be made of metal.
4. All wiring within adjacent heating and air conditioning equipment, for example, shall be shaded from direct line-of-sight from the UV bulb or shall be UV-rated.

# CONTENTS

---

	PAGE
Safety & Installation Concerns	2
Table of Contents/Product Information & Replacement Parts	3
Installation Locations & Tools Required	4
Installation Instructions	5
Troubleshooting, Lamp Replacement & Disposal	6
Warranty	7

## PRODUCT

---

All Second Wind NEMA air purifiers are designed to address Heating and Air Conditioning rooftop air handling units. Second Wind uses ultraviolet germicidal light at a frequency of 254 nanometers to disinfect biological growth on evaporator coils and drain pans as well as purifying recirculated air. Some key features of the Second Wind NEMA 4 series:

- All weather NEMA 4 enclosure
- ETL Listed
- Electronic start 120-277 vac power supply
- Improves efficiency, reduces maintenance
- High Output lamps
- Over 9000 hours lamp expectancy
- Class II medical device
- Registered with the EPA
- Three year unit warranty
- One year lamp warranty

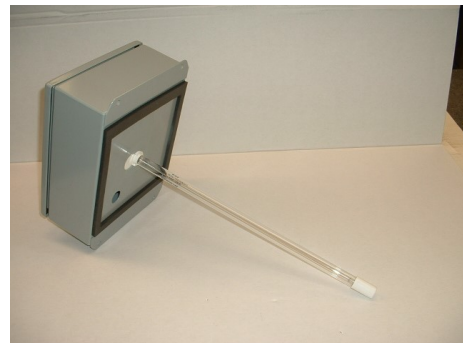

## REPLACEMENT PARTS

---

- 18 inch replacement lamp.....1076-1R SP (GF# 4950)
- 24 inch replacement lamp.....1097BR-SP (GF# 4931)
- 32 inch replacement lamp.....1081-1R SP (GF# 4943)
- Ballast (units mfg before 03/2021).....5000B-R (GF# 4963)
- Ballast (units mfg 03/2021 or later).....1060E-R (GF# 4964)

# MOUNTING LOCATIONS

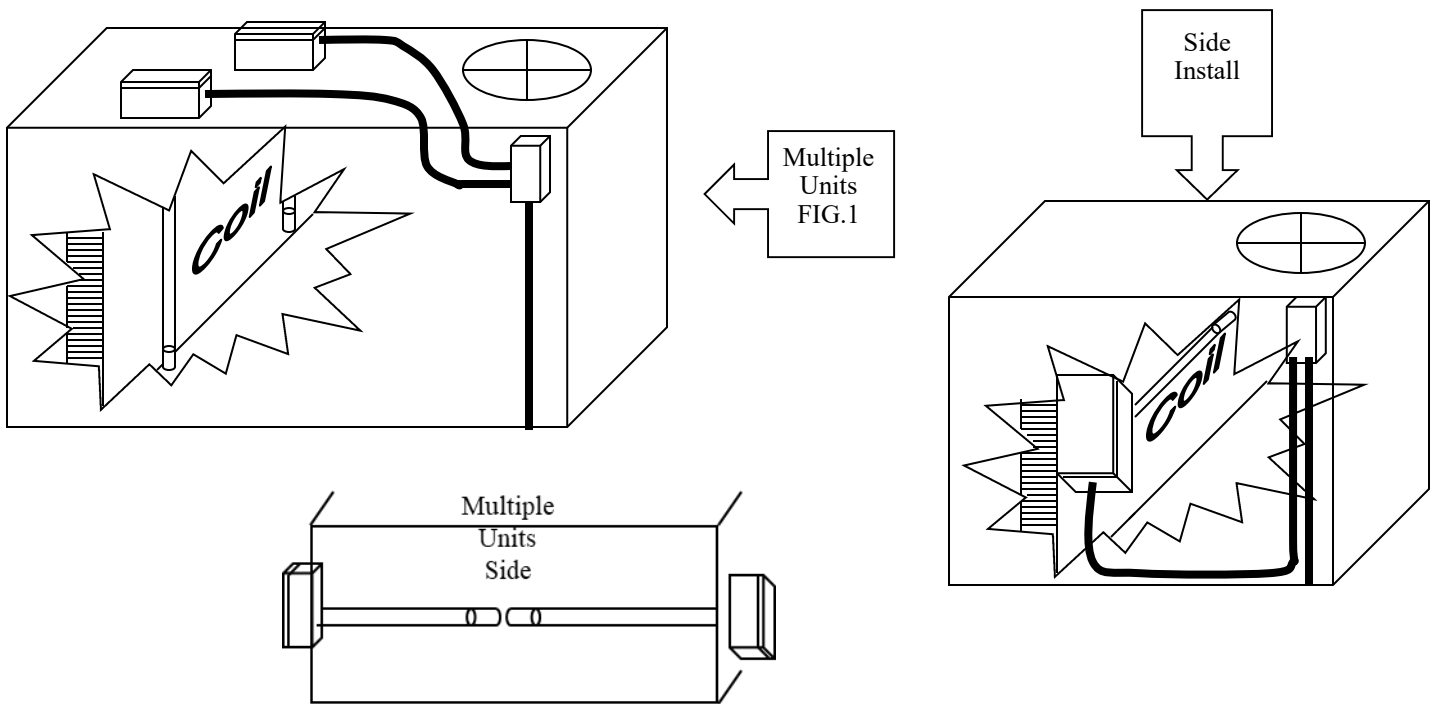

1. Install the lamps where you have easy access.
2. Before drilling into equipment, make sure that there is nothing in the way that would be damaged.
3. The lamp should be installed a minimum of 2-3 inches, maximum 39 inches, away from the coil or pan surface when installing for coil cleaning
4. Use one or more units to treat the coil surface area, as shown in Fig.1 and Fig.2. Areas shaded from direct exposure to the lamps will not be disinfected. The greater the amount of coil and drain pan area exposed to the lamp, the greater the amount of biological disinfection.

## NEMA Series Single Unit Sizing

Tonnage	< 4.5t	5.0t	7.5t	10.0t	12.5t	15.0t
cfm	< 1800	2000	3000	4000	5000	6000
3018						
3024						
3032						
2000-2300D						

## NEMA Series Dual Unit Sizing

Tonnage	20.0t	25.0t	30.0t	40.0t	50.0t
cfm	8000	10000	12000	16000	20000
(2x) 3024					
(2x) 3032					
(2x) 2000-2300D					

# INSTALLATION TOOLS

- Electric Drill
- Flat screwdriver
- 1" to 1-1/2" hole cutter
- Eye protection
- Metal shear tool
- Tape measure
- Marker
- Multimeter
- Weather proof conduit

# INSTALLATION

- The installation should be done by a qualified HVAC contractor. Unit must be installed in compliance with all national and local electrical and mechanical codes. Failure to do so will void UL safety listing and Second Wind warranty.
- Read all safety instructions at the beginning of this manual. Failure to do so could lead to personal injury and/or equipment damage.
- In cases where molds are already present on the evaporator coil, it is recommended that a qualified HVAC technician clean the coil before the installation of the UV lamp.
- Safety interlock switches for access panels on equipment are recommended but not supplied
- **Make sure the rooftop unit power has been shut off at the main power source before installation.**
- **Protect all non-UV resistant materials from direct UV exposure with aluminum tape or metal conduit.**
- **CAUTION: Ultraviolet light can be harmful to your sight, do not look at the lamp when it is illuminated.**

1. Using the Second Wind NEMA unit as a template, mark the (4) mounting holes on the surface where the device is to be installed.
2. Open the enclosure with flat screwdriver.
3. Mark the Ø7/8 conduit hole location for electrical supply
4. For 3000 Series units, mark the position of the smallest diameter on keyhole lamp plate (Fig 1).
5. For 2000-2300D, and trace perimeter of rectangular cutout on enclosure.
6. Cut electrical access hole and lamp access hole or cutout, depending on model, remove all metal and clean rough edges to prevent damage to unit.
7. Secure NEMA enclosure in position and secure with appropriate hardware (not included)
8. Ensure that NEMA enclosure fits flush against the equipment or duct to ensure gasket seal of joint. Seal perimeter of enclosure with outdoor silicone.
9. Remove lamp(s) from tubes inside carton, use an alcohol wipe to remove any dirt or fingerprints from the lamp if present.
10. 3000 Series - insert the lamp into the larger diameter of keyhole, and lower into the smaller diameter. Ensure that the lamp is secured in lower diameter.
11. 2000-2300D only - perform same as #10 on lamp bracket assembly, then secure opposite end of lamps in spring clamps at end of assembly. Install in NEMA enclosure and secure with locknuts.
12. Attach the lamp connector to the lamp. There is only one way to attach the connector to the lamp. If it does not go on, rotate the connector 90 degrees and try again.
13. With the cover of the NEMA enclosure still open, access the ballast and wiring. Install the proper weatherproof conduit on the bottom of the enclosure. Connect the electrical service through the conduit. Connect the black and white wires to power and the green wire to ground. Install access panel disconnect switch, NOT INCLUDED. Refer to the wiring diagram (Fig.3).
14. Place warning labels (included) on the equipment near installed unit or near the power supply.
15. Close the cover, screw the cover closed to make sure the safety interlock switch is activated. Turn on electrical service, unit is always energized.

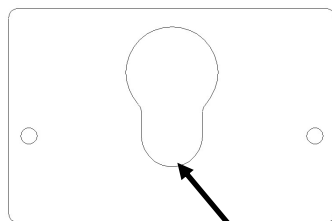

Fig. 1

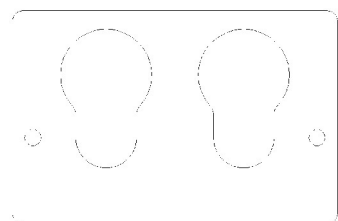
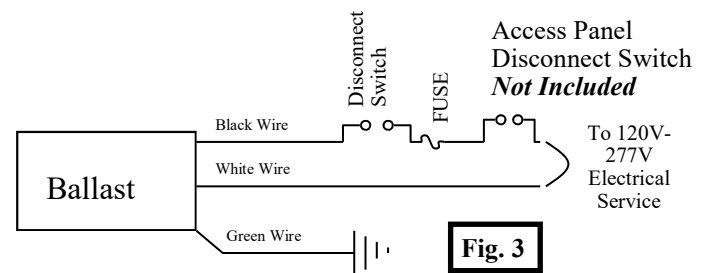

Fig. 2

Lamp sets in bottom of keyhole



# TROUBLESHOOTING

---

If the unit does not work, check the following:

---

**Electrical Supply/Wiring**—Verify that the electrical service is operating correctly.

**Fuse**—If the lamp is still not illuminated, turn off electrical supply and check the fuse. Look to see if FUSE is blown; or check fuse continuity with multi-meter. Replace with part# 102-409 (GF# 4971)

**Ballast**—If lamp still is not illuminating, check the wiring to the ballast. If the ballast is wired properly and the lamp still does not illuminate, replace the ballast. With a fully electronic ballast there is no resistance testing.

**Lamp**—Verify that the lamp is not broken and is properly seated in the lamp connector. To check this, follow steps in the 'Lamp Replacement' section with one exception : you should not remove and replace the lamp. If the lamp is broken, read the 'Lamp Disposal' section of this manual.

## LAMP REPLACEMENT

---

The Second Wind Ultraviolet Germicidal Lamp is designed for 1 year of continuous operation. After 9000 hours, intensity of the lamp inside the duct diminishes and should be replaced. Even if the lamp is still illuminated, replacement of the lamp is recommended, by a qualified HVAC Service Technician.

---

1. Disconnect electrical service
2. Open NEMA enclosure cover.
3. Disconnect the lamp connector from the lamp base.
4. **2000-2300D only** - remove locknuts from lamp bracket assembly, remove lamp from spring clamps at end of lamp
5. **All models** - Remove old lamp(s) **CAUTION:** old lamp may still be hot to touch.
6. Replace the old lamp with new lamp, ensuring the lamp is clean. If dirty, remove w/ alcohol wipe.
7. **2000-2300D only** - secure lamp bracket assembly with locknuts.
8. Attach lamp connector(s) to the lamp base(s).
9. Close the NEMA enclosure cover and screw tight to make sure the interlock switch is activated.
10. Turn on electrical service.

## LAMP DISPOSAL

---

UV lamps contain mercury like other household fluorescent lamps and must be disposed of properly. **State requirements and recycling opportunities vary, go to [www.lamprecycle.com](http://www.lamprecycle.com) for State Regulations & Contacts.** Please contact your county waste collection department for proper disposal details.

### ***USE GLOVES AND EYE PROTECTION***

If a lamp is broken, **do not use a vacuum cleaner to pick up the waste or burn the lamps.** Instead, sweep up the waste into a plastic bag and seal. Contact your county waste collection department for proper disposal details.



**ATTENTION INSTALLERS AND HOMEOWNERS**  
**YOUR SECOND WIND PRODUCT MUST BE REGISTERED TO QUALIFY FOR WARRANTY CLAIMS**  
**CALL 1-866-476-5101 (IN USA) OR 1-888-216-9184 (IN CANADA) FOR ASSISTANCE**

**WARRANTY PROVISIONS**

The Second Wind unit that is attached to your Heating, Ventilation and Air Conditioning System (HVAC) has the following warranty, applicable in USA by General Filters Inc (GFI), and in Canada by Canadian General Filters Limited (CGF)

**ONE (1) YEAR WARRANTY COVERAGE LAMPS**  
 The lamps are warranted for a period of one (1) year from the date of the original installation, when installed and operated in accordance with GFI and CGF recommendations. If during this period a lamp fails, GFI & CGF will provide a free replacement.

**THREE (3) YEAR LIMITED WARRANTY**  
 GFI & CGF warrants this product, excluding lamps to be free from defects in the workmanship or materials, under normal use and service, for a period of three (3) years from the date of original installation, when installed and operated in accordance with GFI & CGF recommendations. If during this period a covered component fails, GFI & CGF will repair or replace the part.

**SHIPPING, REPAIRS AND ALL OTHER COSTS OF WARRANTY SERVICE**  
 End user must pay shipping charges and all other costs of warranty service. GFI & CGF will not pay labor involved in diagnostic calls or in removing, servicing, or replacing parts. All repairs of covered components must be made with authorized service parts. Labor charges resulting from diagnostic calls or service are not covered by this warranty.

**CARE OF EQUIPMENT**  
 Your new Second Wind Air Purifier must be properly installed, operated and maintained in accordance with the unit installation, operation, and maintenance instructions provided with each unit. Failure to provide maintenance per these instructions will void warranty.

**WARRANTY LIMITATIONS**

This warranty will be voided if the covered equipment (only Second Wind replacement parts or units are warranted) is removed from the original installation site. This warranty does not cover damage or defect resulting from:

- 1 Accident, or neglect or unreasonable use or operation of the equipment, including operation of electrical equipment at voltages other than the range specified on the unit name plate.
- 2 Modification, change or alteration of the equipment, except as directed by GFI & CGF The furnishings of replacement parts under terms of this warranty will apply to the original warranty period and will not extend the warranty.

GFI & CGF makes no express warranties other than the warranty specified above. All implied warranties, including the implied warranty of merchantability and fitness for a particular purpose, are limited to the duration of the warranty specified above. Liability for incidental and consequential damages is excluded and is not covered by this warranty. Some States do not allow limitations on the duration of an implied warranty or the exclusion or limitation of incidental or consequential damages, so the limitations or exclusions may not apply to you.

This warranty gives you specific legal rights, and you may also have other rights which vary from state to state. General Filters Inc & Canadian General Filters Limited shall not be liable for any default or delay in performance under this warranty caused by any contingency beyond their control.

**WARRANTY PROCEDURE**

All Second Wind Air Purification systems that are attached to your Heating, Ventilation and Air Conditioning System (HVAC) have a limited unit warranty. To receive warranty consideration, the following must be provided.

- 1 Be prepared to furnish the following information:
  - a- Complete model number and serial number
  - b- Proof of installation date if warranty claim is made by other than a qualified service dealer who maintains records of your installation date and service history.
  - c- An accurate description of the problem.
  - d- Date of failure.
- 2 Call the installing dealer that you purchased your Second Wind device from.
- 3 If the installing dealer is unable to provide warranty parts, contact:
 

General Filters Inc,	Canadian General Filters Limited
43800 Grand River Ave	400 Midwest Road
Novi, MI 48375	Toronto, ON M1P3A9
Phone: 1-866-476-5101	Phone: 1-888-216-9184