

This Owner's Manual is provided and hosted by [Appliance Factory Parts](#).



FRIGIDAIRE EC200WF Owner's Manual

[Shop genuine replacement parts for FRIGIDAIRE
EC200WF](#)



[Find Your FRIGIDAIRE Evaporative Cooler Parts - Select From 4 Models](#)

----- Manual continues below -----

FRIGIDAIRE

Evaporative Air Cooler and Tower Fan EC200WF Owner's Manual



Intertek

Manual v1.2

READ AND SAVE THESE INSTRUCTIONS.

TABLE OF CONTENTS

Register Your Product Online.....	3
Safety Information & Warnings	4
Parts List.....	5
Features	6
Operating Instructions	7
Cleaning And Maintenance	11
Limited Manufacturer's Warranty	12

SPECIFICATIONS

MODEL NO	EC200WF
RATED VOLTAGE	120V
RATED FREQUENCY	60 Hz
RATED POWER	65W
NOISE	≤55dB
AIRFLOW	350 CFM
COVERAGE	250 square feet
DIMENSIONS	Depth: 12.7 in Width: 12.8 in Height: 31.4 in

Frigidaire is a registered trademark of Electrolux Home Products, Inc.
All rights reserved.

Manufactured under license by:
NewAir, LLC
6600 Katella Ave, Cypress, CA 90630
Comments/questions:
support@newair.com | 855-963-9247

REGISTER YOUR PRODUCT ONLINE

Register Your Frigidaire Product Online Today!

Take advantage of all the benefits product registration has to offer:



Service and Support

Diagnose troubleshooting and service issues faster and more accurately



Recall Notifications

Stay up to date on safety notices, system updates, and recall notifications



Special Promotions

Opt-in for NewAir promotions and offers.

Registering your product information online is safe & secure and takes less than 2 minutes to complete:

newair.com/register

Alternatively, we recommend you attach a copy of your sales receipt below and record the following information, which can be found on the manufacturer's nameplate on the back of the unit. You will need this information if it becomes necessary to contact the manufacturer for service inquiries.

Date of Purchase: _____

Serial Number: _____

Model Number: _____

SAFETY INFORMATION & WARNINGS



In order to use the product safely and to avoid any danger caused by incorrect operation, please pay close attention to the warnings and instructions in this manual.

- Please read all instructions carefully before using this product.
- Before use, please check whether the operating voltage matches the voltage on the label of the unit.
- Cleaning and user maintenance should not be done by children without adult supervision.
- **WARNING:** Unplug or disconnect the appliance from the power supply before servicing or cleaning.
- The appliance is exclusively for household and indoor use.
- This appliance has a polarized plug with one blade that is wider than the other. To reduce the risk of electric shock, this plug is intended to fit in a polarized outlet only one way. If the plug does not fit fully in the outlet, reverse the plug. If it still does not fit, contact a qualified electrician. Do not attempt to override this safety feature.
- **WARNING:** To reduce the risk of fire or electric shock, do not use this fan with any solid-state speed control device.
- **WARNING:** Chemical Burn Hazard. Keep batteries away from children.
- This product contains a lithium button/coin cell battery. If a new or used lithium button/coin cell battery is swallowed or enters the body, it can cause severe internal burns and can lead to death in as little as 2 hours. Always completely secure the battery compartment. If the battery compartment does not close securely, stop using the product, remove the batteries, and store it away from children. If you think batteries might have been swallowed or placed inside any part of the body, seek immediate medical attention.

PARTS LIST

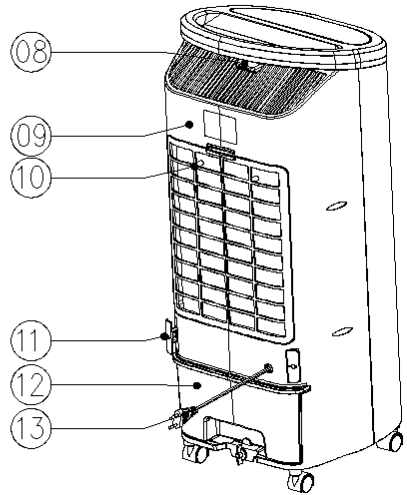
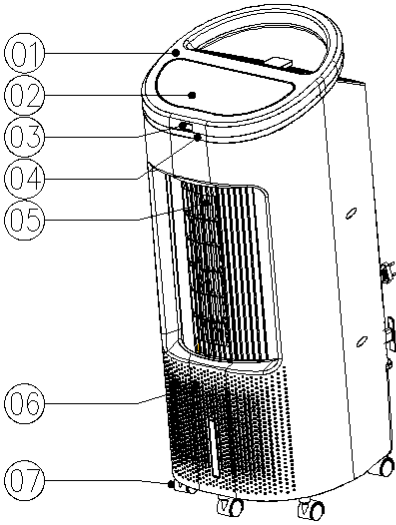

1. Top Cover
2. Display Panel
3. Remote Control Sensor
4. Decorative Ring
5. Fan Outlet
6. Front Shell
7. Casters

8. Remote Control Storage
9. Rear Case
10. Air Intake/Filter
11. Cord Storage Brackets
12. Water Tank
13. Power Cord

FEATURES

1. Four fan speeds: quiet, low, medium, high
2. Three fan modes: normal, nature, and sleep mode
3. Four timer settings: 1h, 2h, 4h, 8h
4. Low water protection function
5. Wide angle fan oscillation
6. Remote control (maximum range 6m, left/right 60° from sensor)
7. Fan-only mode
8. Power failure memory function
9. Touch screen controls
10. Automatic shutoff after 15 hours of continuous operation

OPERATING INSTRUCTIONS

Remove the product from the packaging and review the instructions and other included accessories. The unit can be used immediately after being removed and unpacked.

FILLING THE WATER TANK

We recommend filling your water tank first before operating the unit, so that the evaporative cooling will be functional right away. The water tank can be pulled out of the bottom of the back of the unit, and filled up to the max fill line. Your unit comes with ice packs, which can be placed inside the tank on the left side (there should be an icon indicating this location). These will help the cooler put out even colder air.

Once the water tank is full, press the On/Off button. Then, press the Cooler/Humidifier button to turn on the water pump. The water pump will enable evaporative cooling, as it draws water up and runs it through the cooling pad.

USING THE REMOTE CONTROL





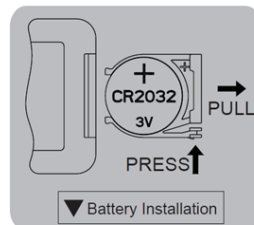
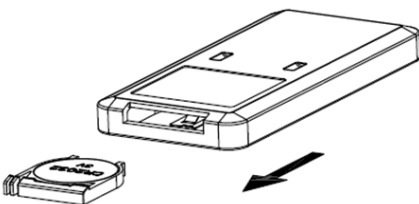

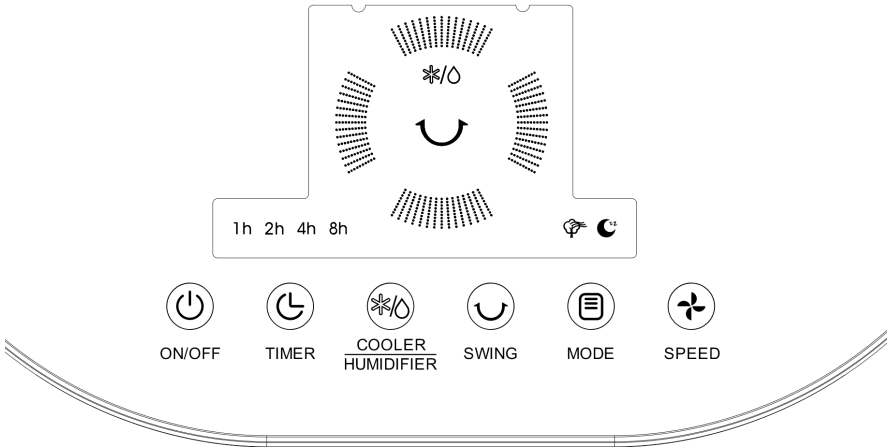

One battery (CR2032 3V) is used in the remote control. Please insert the battery into the remote control tightly based on the direction of the polarity. If the remote will not be used for a long time, please remove the battery and store safely.

Used batteries should be disposed of properly, and kept away from children. Please note that even used batteries could be hazardous.



CONTROL & DISPLAY PANELS



1	 ON/OFF	On/Off
2	 TIMER	Timer setting: 1, 2, 4, 8 hours
3	 COOLER HUMIDIFIER	Humidification, or evaporative cooling
4	 SWING	Fan oscillation
5	 MODE	Mode selection: Normal, nature (), sleep ()
6	 SPEED	speed control: High, medium, low, silent

CONTROL PANEL USE

When the unit is first turned on with the On/Off button, it will beep twice, the air outlet will rotate from the current angle to 0°, and the system enters the standby state. If there is no button operation within 1 minute, the indicator light will darken. If the button is pressed again, the indicator light will turn back to full brightness.

The unit can be operated by pressing the button on the control panel. The instructions are as follows:

ON/OFF CONTROL

Press the “On/Off” button for the first time to enter the normal fan speed—this will cause the air outlet to automatically rotate out toward the front. Press the “On/Off” button again to shut down—this will cause the fan to stop running and hide the air outlet. At this point, the fan is in standby mode. To completely turn off the fan, press the On/Off button.



Note: In order to extend the life of the product, it is recommended to completely power off the product after each use

TIMER

Press the “Timer” button to select 1 hour, 2 hours, 4 hours or 8 hours. If the LED is off, it means that the timer function is not set. After selecting the time, the LED indicator will display the set time and will automatically shut down after the selected time has elapsed.



COOLER/HUMIDIFIER

Press the “Cooler/Humidifier” button to enable the water pump. If the water pump is running, water will flow down through the cooling pad and offer cooler air than the fan-only setting.



SWING FUNCTION

Press the “Swing” button to make the fan oscillate at a range of 50 degrees, and then press it again to stop the oscillation.



SWING

MODE SELECTION

Press the “Mode” button to select normal mode, nature mode or sleep mode, and the LED indicator will light up accordingly: Nature mode (), sleep mode ().



MODE

Nature mode: The fan is automatically set to match the air conditioner, and will occasionally change speeds, mimicking a natural breeze.

Sleep mode: The fan speed changes at regular intervals to provide a comfortable sleeping environment. In sleep mode, the high, medium, and low speeds will all be cycled through.

Note: In nature mode, the fan speed button is not available, so the speed indicator will not light up on the top control panel.

FAN SPEED SELECTION

After the power is turned on, the fan will begin in normal mode. You can press the “Speed” button to change the fan speed to high, medium, low, and silent. The LED indicator will light up accordingly: High → Medium → Low → Quiet



SPEED

Note: If you select the low speed, the motor will start at medium speed for a few seconds and then switch to low speed.

When the fan is turned on in standby state, all functions except timer and sleep mode have memory settings.

CLEANING AND MAINTENANCE

1. When cleaning, use ordinary detergent and a soft brush. Do not use chemical agents for cleaning.
2. Always unplug the power cord before cleaning the device to prevent possible electrocution.
3. If dust accumulates on the outer surface of the unit, please wipe with a damp soft cloth. Use a water and a soap mixture to clean the exterior.
4. Remove the cooling pad from the unit and check to make sure the cooling pad is in good condition. If the pad is cracked, it will need to be replaced. Wipe the interior clean with a damp soft cloth.
5. Rinse the cooling pad completely with clean water. Use a soft cloth to dry.
6. For a more thorough cleaning, use a mixture of water with a couple teaspoons of distilled white vinegar or lemon juice.
7. Do not use gasoline, thinner, or any substance that may damage the unit
8. Change water in the water tank regularly. Wipe the tank clean and use your diluted vinegar solution to remove any hard water stains in the tank.
9. Make sure the tank is completely dry and free of any leftover vinegar residue before using the unit again.
10. Be careful handling the appliance while cleaning, as working around the appliance with wet hands may cause electric shock.
11. After cleaning, ensure the outer dust filter, cooling pad and water tank are correctly installed before use.

CLEANING THE SURFACE OF THE UNIT

1. To clean the surface of the machine, wipe with a damp cloth. It is strictly prohibited to rinse directly with water. Never submerge the unit in water.
2. Do not use corrosive detergent or solvent.
3. When cleaning the body, be sure to turn off the power switch and unplug the power cord, or else it may cause electric shock.

MAINTENANCE

1. When the product is not going to be used for an extended period, unplug the power cord, package the product, and store in a way that prevents dust buildup.
2. After packaging, store in a dry and well-ventilated location.

LIMITED MANUFACTURER'S WARRANTY

This appliance is covered by a limited manufacturer's warranty. For one year from the original date of purchase, the manufacturer will repair or replace any parts of this appliance that prove to be defective in materials and workmanship, provided the appliance has been used under normal operating conditions as intended by the manufacturer.

Warranty Terms:

During the first year, any components of this appliance found to be defective due to materials or workmanship will be repaired or replaced, at the manufacturer's discretion, at no charge to the original purchaser. The purchaser will be responsible for any removal or transportation costs.

Warranty Exclusions:

The warranty will not apply if damage is caused by any of the following:

- Power failure
- Damage in transit or when moving the appliance
- Improper power supply such as low voltage, defective household wiring or inadequate fuses
- Accident, alteration, misuse or abuse of the appliance such as using non-approved accessories, inadequate air circulation in the room or abnormal operating conditions (extreme temperatures)
- Use in commercial or industrial applications
- Fire, water damage, theft, war, riot, hostility or acts of God such as hurricanes, floods, etc.
- Use of force or damage caused by external influences
- Adjustments to temperature by removal of stickers and/or screws
- Partially or completely dismantled appliances

Obtaining Service:

When making a warranty claim, please have the original bill of purchase with purchase date available. The purchaser will be responsible for any removal or transportation costs. Replacement parts and/or units will be new, remanufactured or refurbished and are subject to the manufacturer's discretion.

For technical support and warranty service, please email support@newair.com