

This Owner's Manual is provided and hosted by [Appliance Factory Parts](http://ApplianceFactoryParts.com).



Alfresco ALXE-30 Owner's Manual

[Shop genuine replacement parts for Alfresco ALXE-30](#)



[Find Your Alfresco Grill Parts - Select From 126 Models](#)

----- Manual continues below part list -----

Available Replacement Parts for Alfresco ALXE-30

290-0052	INFRARED SEARING BURNER
265-0005	CERAMIC BRIQUETTES(24 pcs)
210-0189	L SHAPED ELECTRODE
290-0059	ROTISSERIE DRIP PAN
100-0917	GAS LINE 8 IN L X 3/8 IN DIA FLEX SS TUB
220-0273	ELBOW 90 DEGREE
220-0277	NIPPLE
220-0280	REGULATOR-GAS
290-0041	GAS VALVE, STRAIGHT, NO ORIFICE
290-0066	VALVE GAS-ANGLED
290-0096	FORK ASSEMBLY (PAIR)
290-0116	CHAIN-ANSI 25-1/4 PITCH-.13 ID X 1/8 ROL
290-0124	GRILL 30 IN BBQ-12 3/4 IN WIDE-SS
510-0913	SEAR ZONE GRILL
200-0148	SCREW 10-32 X 3/4 FLAT HEAD PHILIPS 82 D
290-0119	ROLLER WHEEL-STAINLESS STEEL-3/4 IN DIA
510-0139	ROTISSERIE GEAR ASSEMBLY.
220-0290	ORIFICESEAR ZONE-LP.
210-0192	ELECTRODE
210-0240	ELECTRODE-DUAL TIP IR BURNERS.
100-0913	SMOKER GAS LINE 3/16 DIA. AL TUBING
210-0286	REPLACEMENT GLASS
12541	burner, center-fed pipe, ss, 18.125 x 7.
210-0571	THERMOMETER
290-0123	SPEAR-ROTISSERIE 30IN
510-0504	SMOKER BURNER
100-1846	U-burner bracket
100-1848	IGNITER BRACKET
290-0311	GAS VALVE
210-0465	IGNITER MODULE

510-0522	Briquette Tray Assy
290-0433	CONTROL KNOB
210-0317	LAMP 40W
210-0583	SWITCH - IGNITION - MOMENTARY [ON]/OFF.
210-0585	SWITCH - ROTISSERIE - LATCHING [ON/OFF].
290-0388	BEZEL RING.
510-0964	FRONT HOOD ASSEMBLY.
510-0484	WARMING RACK BRACKET LEFT SIDE . PLEASE
100-1894	BRIQUETTE TRAY BASE .
100-1895	BRIQUETTE LOCK BAR.
290-0434	ROTISSERIE KNOB.
210-0509	LAMP ASSEMBLY 32 IN. WIRE.
210-0510	LAMP ASSEMBLY 56 IN WIRE.
210-0520	IGNITER WIRE KIT.
210-0626	PERIMETER LIGHT SWITCH.
210-0584	SWITCH LIGHT LATCHING.

Alfresco™

Open Air Culinary Systems

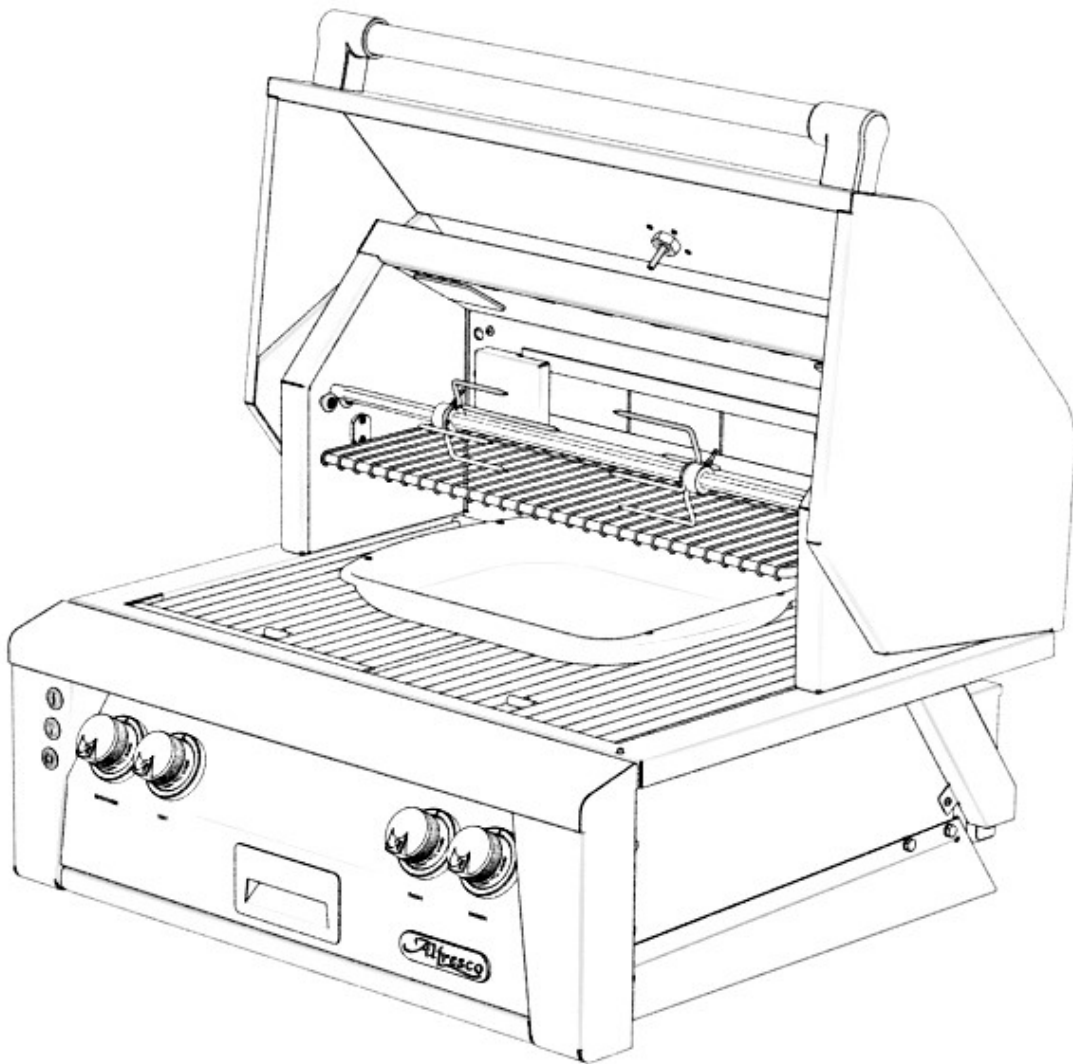

ALXE-30 & 30SZ Parts Manual
Serial Numbers up to 17-99999

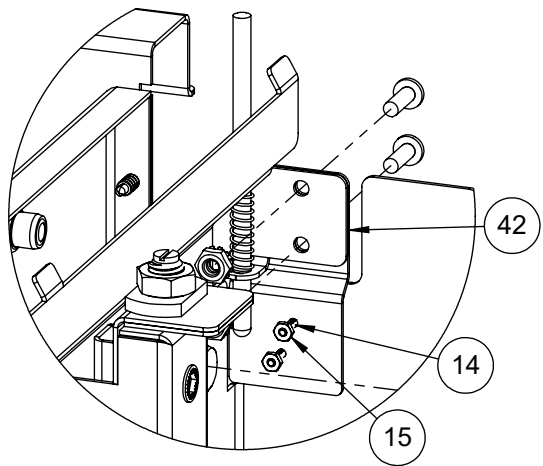

DETAIL OF HOOD SWITCH MECHANISM
 FASTENERS 14 & 15 ARE FOR
 ATTACHING THE SWITCH 210-0626
 SEE ELECTRICAL COMPONENTS

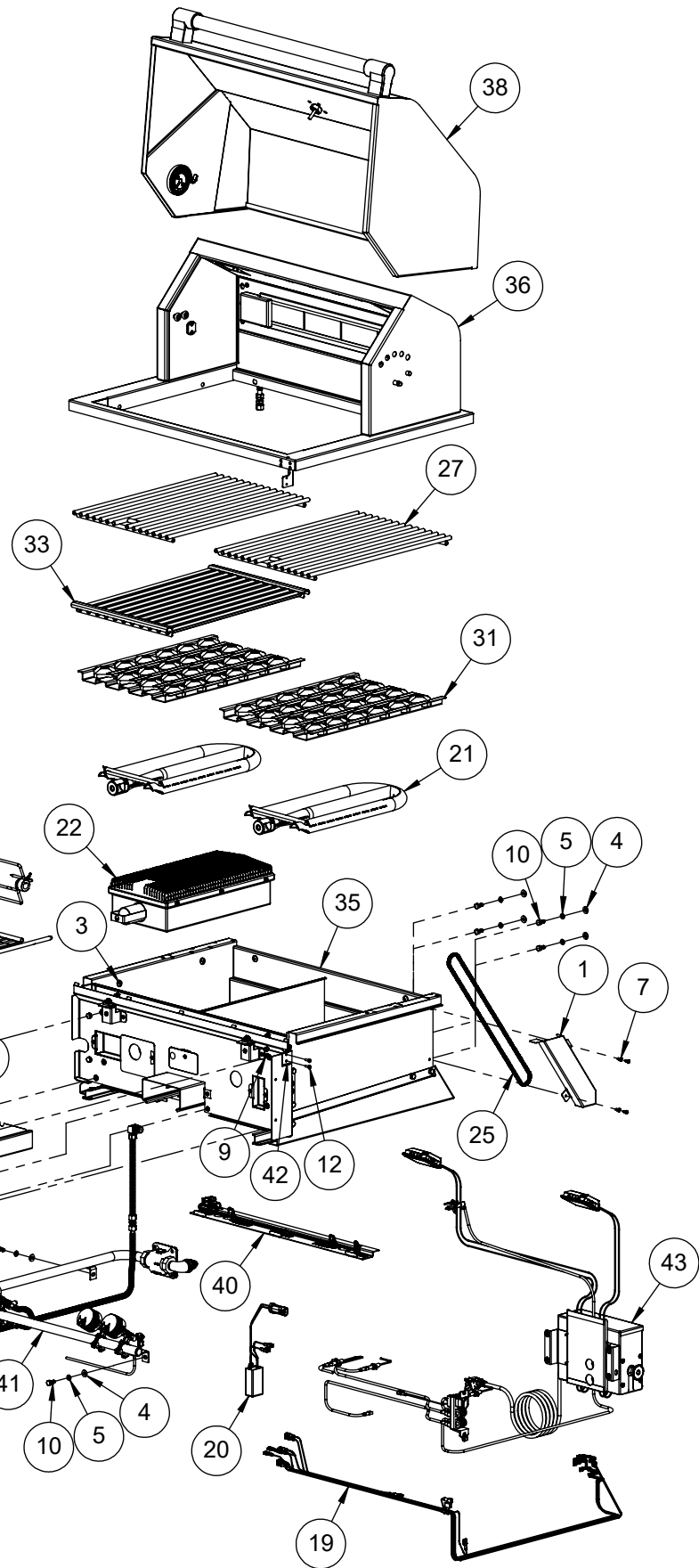

NOTE:

SEARCHZONE™ BURNER 22 AND GRILL 33 USED ON ALXE-30SZ

OTHERWISE, ONLY BURNER 21, GRILL 27 AND BRIQUETTE 31 USED ON ALXE-30

ITEM	PART NUMBER	DESCRIPTION	QTY
1	100-1877	ALX2 - ROTISSERIE CHAIN COVER	1
2	130-3068	FRONT PANEL	1
3	200-0057	SCREW 1/4-20 X 1/2 - TRUSS HEAD - PHILLIPS	8
4	200-0074	FLAT WASHER 1/4 TYPE A NARROW	7
5	200-0087	WASHER - 1/4" SPRING LOCK- REGULAR - SS	15
6	200-0089	BOLT - HEX HEAD 1/4-20 x 1/2" L	8
7	200-0111	SCREW 8-18 X 1/2 - SELF TAP - 410 SS	6
8	200-0125	NUT THREAD CUTTER FOR 1/4" Ø STUD -SPEED NUT	2
9	200-0206	8-32 KEP NUT 18-8 STAINLESS	2
10	200-0219	HEX HD MACHINE SCREW 1/4-20 UNC X 5/8 LONG SS	7
11	200-0267	10-32 X 1/2 - PAN HEAD - PHILLIPS SCREW	6
12	200-0270	8-32 PAN HD X 1/2 PHILLIPS 18-8 SS	2
13	200-0348	Screw 6-32 x 3/8 Flat Head (82°) phillips - Thread Cutter - #2 Drive - SS 410	8
14	200-0362	18-8 SS PAN HEAD SCREW 2-56 X 3/8	2
15	200-0363	18-8 SS NUT 2-56	2
16	210-0583	SWITCH - IGNITION - MOMENTARY [ON]/OFF	1
17	210-0584	SWITCH - LIGHT - LATCHING [ON/OFF]	1
18	210-0585	SWITCH - ROTISSERIE - LATCHING [ON/OFF]	1
19	210-0598	ALXE-30 WIRING HARNESS	1
20	210-0623	TRANSFORMER ASSY FOR ALXE	1
21	290-0038	BURNER - GRILL - "U" SHAPE	2
22	290-0052	ALFRESCO SEAR ZONE™ BURNER ASSEMBLY	1
23	290-0059	ROTISSERIE DRIP PAN	1
24	290-0096	FORK ASSEMBLY	2
25	290-0116	CHAIN - ANSI # 25 - 1/4" PITCH - .13" Ø X 1/8" ROLLER	1
26	290-0123	SPEAR - ROTISSERIE - 30" - 2006 BBQ	1
27	290-0124	GRILL 30" BBQ - 12 3/4" WIDE - SS	2
28	290-0315	ALX2-30 WARMING RACK - SS	1
29	290-0377	ALFRESCO RANGE LOGO	1
30	290-0388	ALFRESCO RANGE KNOB - BEZEL RING	4
31	510-0522	ALX2 - BRIQUETTE TRAY ASSEMBLY	2
32	510-0912	ALXE SMOKER BOX	1
33	510-0913	SEARZONE™ GRILL ASSEMBLY	1
34	510-0918	ALXE SMOKER BURNER ASSEMBLY	1
35	510-0942	ALXE-30 FIREBOX MAIN ASSEMBLY	1
36	510-0957	REAR HOOD & RIM ASSEMBLY	1
37	510-0963	FRONT PANEL PERIMETER	1
38	510-0964	FRONT HOOD ASSEMBLY	1
39	510-0967	DRIP TRAY ASSEMBLY	1
40	510-0998	ALXE-30 LED LIGHT FIXTURE	1
41	510-1005	ALXE-30 AND 30SZ GAS MANIFOLD ASSEMBLY	1
42	510-1026	ALXE HOOD SWITCH MECHANISM	1
43	510-1051	ALXE-30 AND 30SZ ELECTRICAL COMPONENTS	1

ITEM	PART NUMBER	DESCRIPTION	QTY
1	100-1065	SEARZONE™ OPENING FIREBOX COVER	1
2	100-1846	ALX2 - U-BURNER BRACKET	2
3	100-1847	ALX2 - SEAR-ZONE IGNITER BRACKET / SHIELD	1
4	100-1848	ALX2 - IGNITER SHIELD	2
5	100-1849	ALX2 - IGNITER HOLE COVER	1
6	100-1884	ALX2 - SEAR-ZONE™ BURNER BRACKET	1
7	100-1887	ALX2 - DUAL VALVE FIREWALL COVE	1
8	100-1888	ALX2 - SINGLE VALVE FIREWALL COVE	1
9	100-1890	ALX2 - FIREWALL OPENING COVER FOR SEARZONE™	1
10	100-1945	ALX2 - DUAL VALVE FIREWALL COVER FOR U-BURNER	1
11	100-1946	ALX2 - FIREWALL OPENING COVER FOR U-BURNER	1
12	130-3039	ALXE SMOKER BOX BODY	1
13	130-3040	ALXE SMOKER BOX TOP DIFFUSER	1
14	130-3041	FLUE	1
15	130-3042	ALX4 SEAR ZONE BURNER SHIELD	1
16	130-3047	REAR COVER PLATE	1
17	200-0087	WASHER - 1/4" SPRING LOCK- REGULAR - SS	13
18	200-0089	BOLT - HEX HEAD 1/4-20 x 1/2" L	13
19	200-0111	SCREW 8-18 X 1/2 - SELF TAP - 410 SS	28
20	510-0502	ALX2 - GREASE TRAY SUPPORT - RIGHT SIDE	1
21	510-0503	ALX2 - GREASE TRAY SUPPORT - LEFT SIDE	1
22	510-0520	ALX2 - FIREWALL SUPPORT BRACKET ASSEMBLY	2
23	510-0943	ALXE-30 / 30SZ FIREBOX WELDED PARTS	1
24	510-1006	FIREWALL ASSEMBLY	1

ITEM	PART NUMBER	DESCRIPTION	QTY
1	130-3093	DRIP TRAY INSERT	1
2	200-0109	RIVNUT, HEX THREADED INSERT # 10 - 32 THREAD CLOSED END	6
3	200-0148	SCREW 10-32 X 3/4" - FLAT HEAD - PHILIPS - 82° - SS	6
4	290-0119	ROLLER WHEEL - STAINLESS STL - 3/4" Ø -	6
5	510-0966	ALXE-30 DRIP TRAY	1

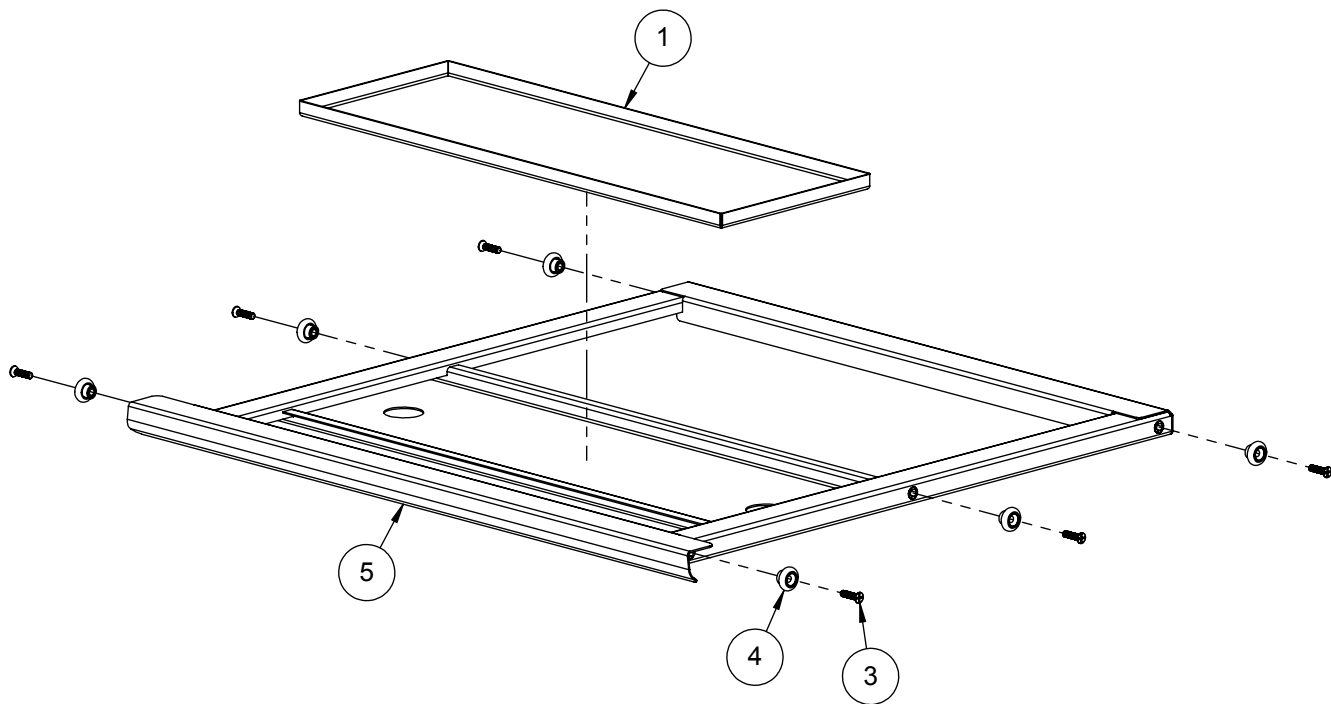

ITEM	PART NUMBER	DESCRIPTION	QTY
1	100-1092	ALX2 - ROTISSERIE GEAR COVER	1
2	130-2985	PIVOT PIN	2
3	200-0057	SCREW 1/4-20 X 1/2 - TRUSS HEAD - PHILIPS	2
4	200-0062	10-32 X 3/4 - PAN HEAD - PHILIPS SCREW	2
5	200-0087	WASHER - 1/4" SPRING LOCK- REGULAR - SS	4
6	200-0089	BOLT - HEX HEAD 1/4-20 x 1/2" L	4
7	200-0111	SCREW 8-18 X 1/2 - SELF TAP - 410 SS	1
8	200-0148	SCREW 10-32 X 3/4" - FLAT HEAD - PHILIPS - 82° - SS	2
9	200-0361	SCREW 8-32 X 5/8" - FLAT HEAD 82° - PHILIPS	4
10	290-0119	ROLLER WHEEL - STAINLESS STL - 3/4" Ø -	2
11	510-0139	ALX2 - ROTISSERIE GEAR ASSEMBLY	1
12	510-0478	ALX2-30 / 30SZ - ROTISSERIE PANEL ASSY	1
13	510-0483	ALX2-30 / 30SZ- WARMING RACK BRACKET - RT SIDE	1
14	510-0484	ALX2-30 / 30SZ - WARMING RACK BRACKET-LT SIDE	1
15	510-0958	REAR HOOD & RIM WELDED PARTS	1

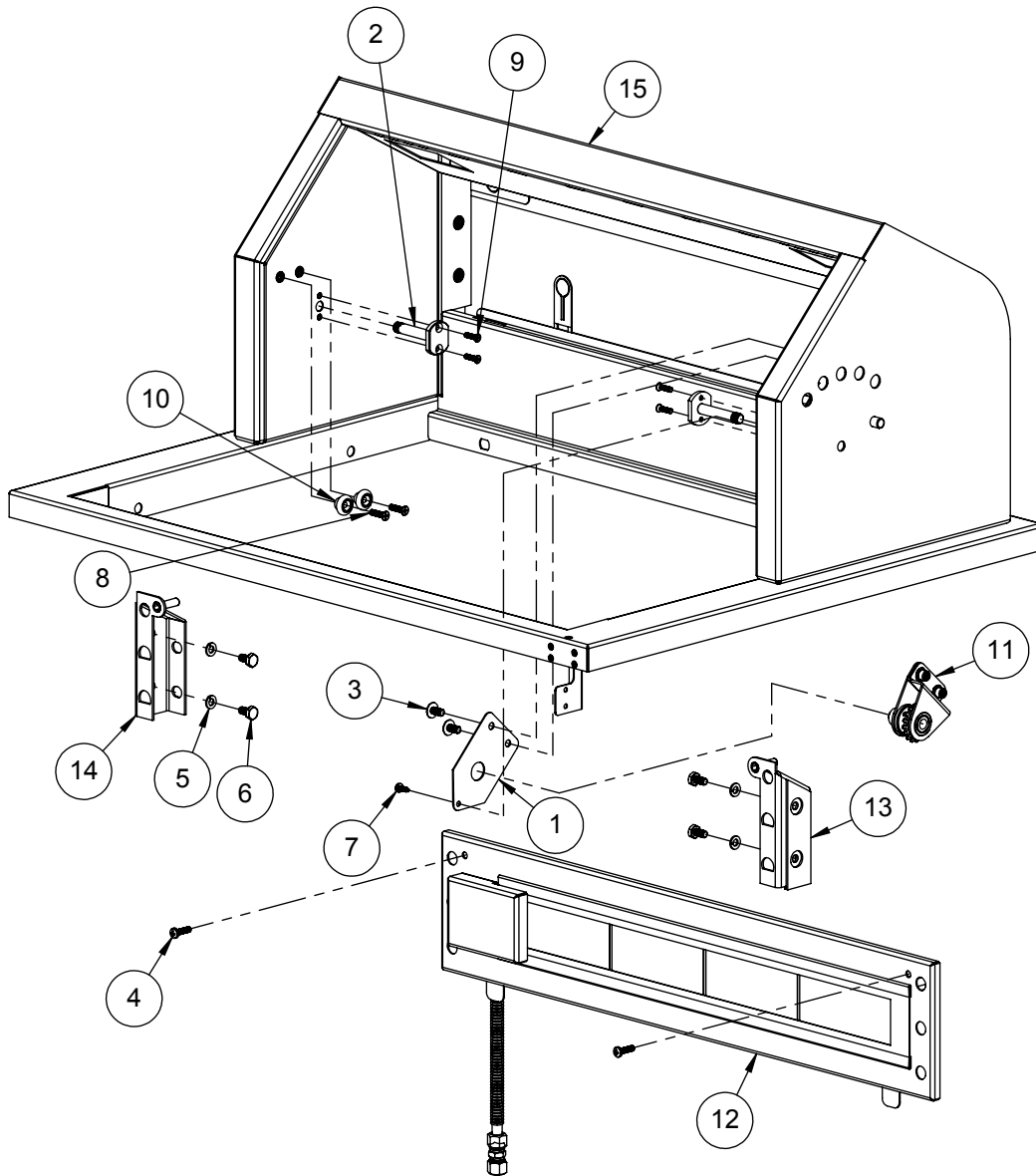

ITEM	PART NUMBER	DESCRIPTION	QTY
1	100-1986	ALX2-30 / 30SZ - ROTISSERIE BURNER IGNITER BRAKET	1
2	100-1987	ALX2-30 / 30SZ - ROTISSERIE BURNER IGNITER COVER	1
3	200-0111	SCREW 8-18 X 1/2 - SELF TAP - 410 SS	5
4	210-0240	ELECTRODE - DUAL TIP "L" SHAPE- ROTISSERIE	1
5	510-0469	ALX2 - ROTISSERIE PIPING SUBASSEMBLY	1
6	510-0482	ALX2-30 / 30SZ - ROTISSERIE PANEL - WELDED PARTS	1

ELECTRODE SHOWN FOR ASSEMBLY PURPOSES ONLY
REFER TO ASSEMBLY DRAWING 510-0494M FOR ALL
ELECTRICAL COMPONENTS

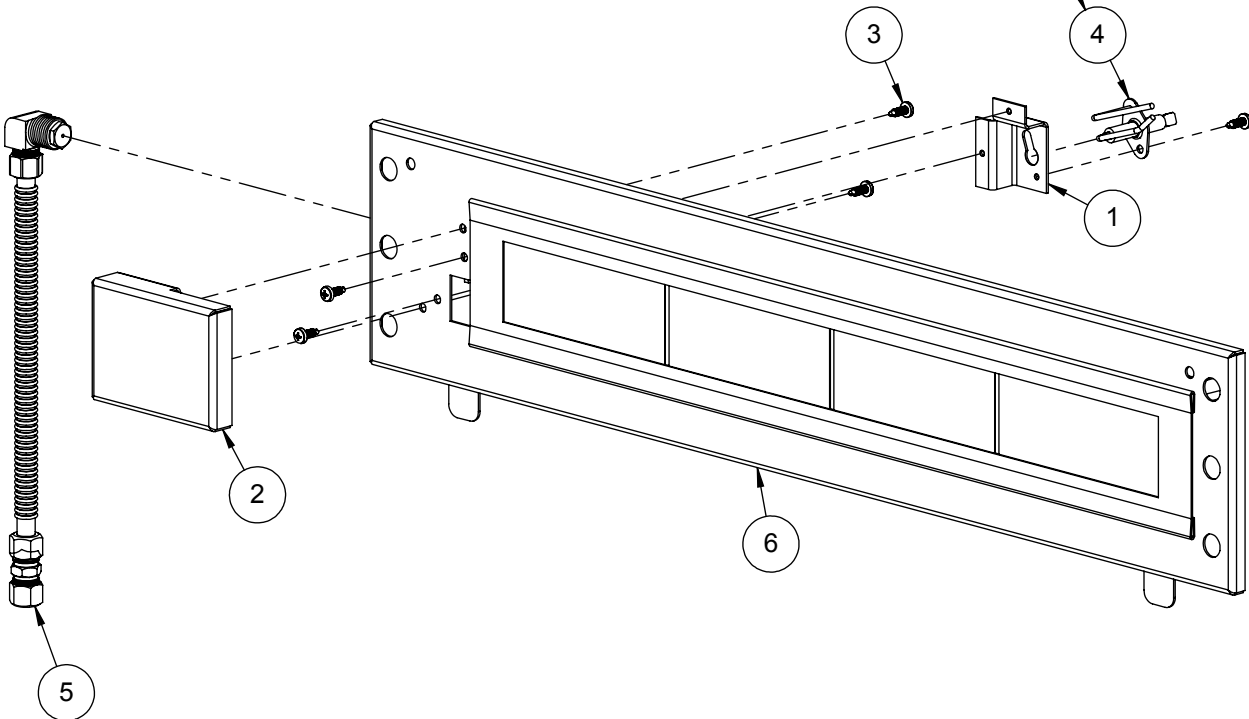

THESE PARTS ARE SHOWN FOR ASSEMBLY PURPOSES ONLY
REFER TO ASSEMBLY DRAWING 510-1005M FOR COMPLETE
PARTS BREAKDOWN AND ORIFICE INFORMATION

ITEM	PART NUMBER	DESCRIPTION	QTY
1	200-0087	WASHER - 1/4" SPRING LOCK- REGULAR - SS	4
2	200-0219	HEX HD MACHINE SCREW 1/4-20 UNC X 5/8 LONG SS	4
3	200-0361	SCREW 8-32 X 5/8" - FLAT HEAD 82° - PHILIPS	4
4	210-0571	ALFRESCO 3-1/8 DIA ALXE THERMOMETER	1
5	290-0400	ALFRESCO BBQ / RANGE HANDLE END CAP	2
6	290-0442	ALXE-30 barbecue hood handle	1
7	510-0924	SPIRAL TORSION SPRING LT	1
8	510-0925	SPIRAL TORSION SPRING RT	1
9	510-0965	FRONT HOOD (WELDED PARTS)	1

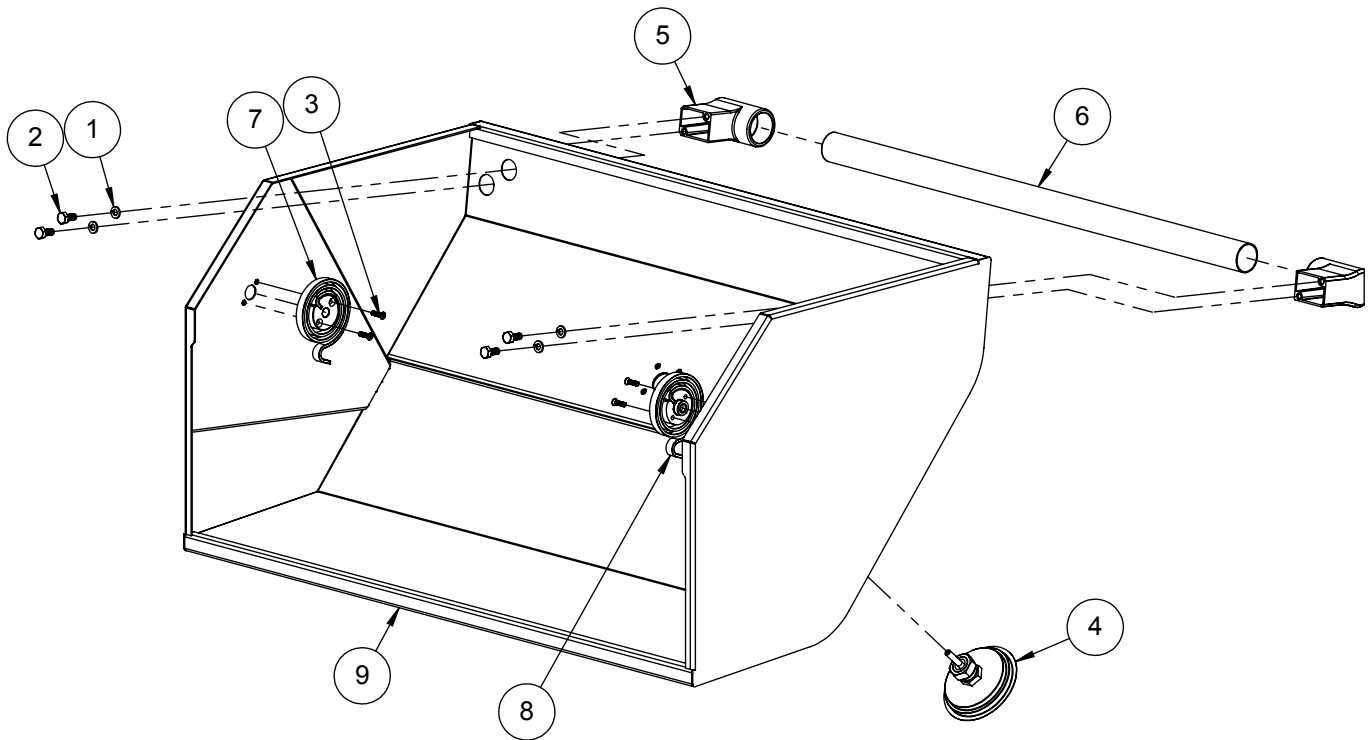

ITEM	PART NO.	DESCRIPTION	QTY
1	100-1894	ALX2 - BRIQUETTE TRAY BASE	1
2	100-1895	ALX2 - BRIQUETTE LOCK BAR	3
3	200-0312	SCREW 8-32 x 3/4"- PAN HEAD - PHILIPS - THREAD CUTTER TYPE F	9
4	265-0005	BRIQUETTE - ALFRESCO CUSTOM	24

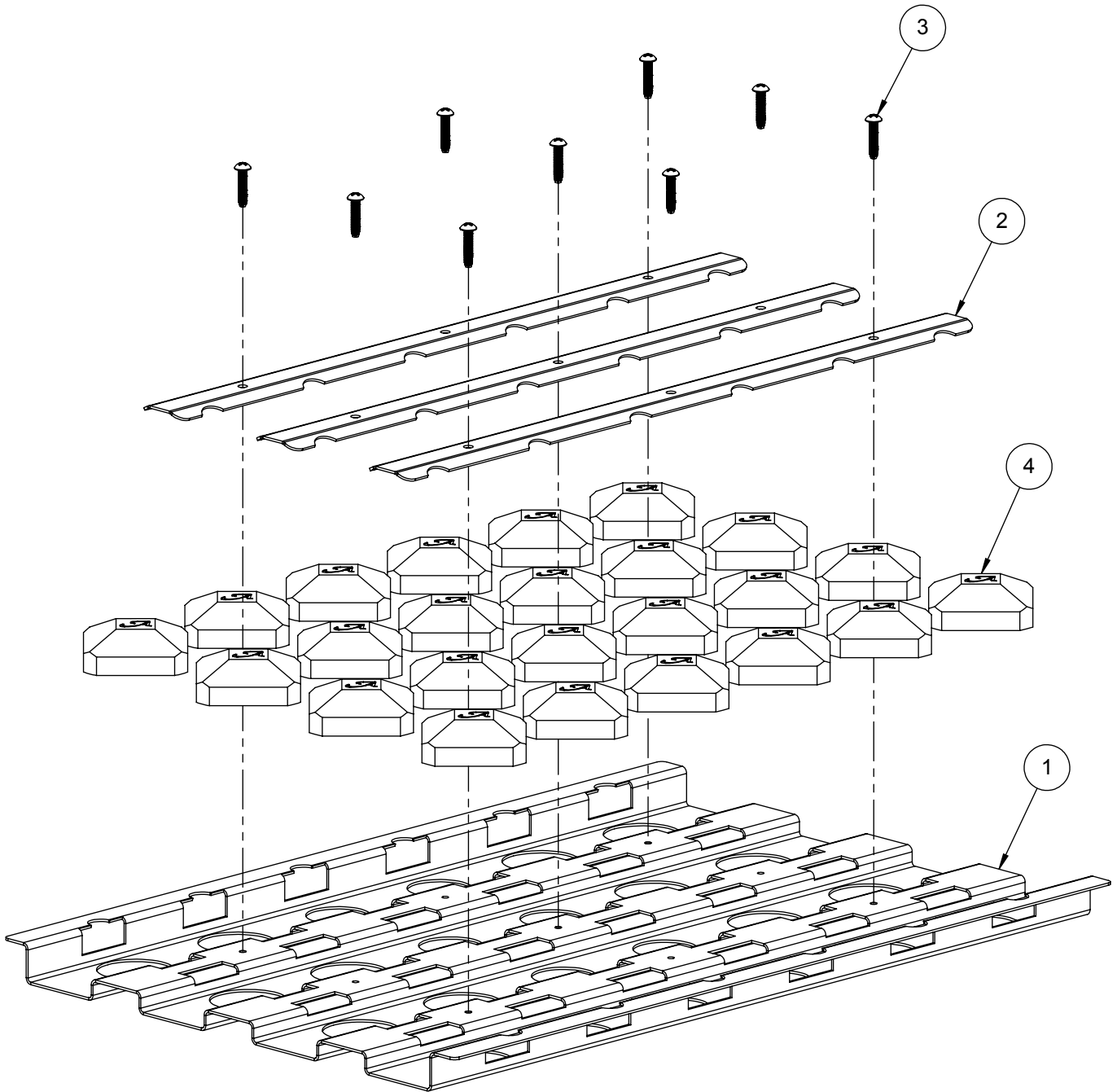

ITEM	PART NUMBER	DESCRIPTION	QTY
1	100-0913	30" & 56" BFG BBQ SMOKER GAS LINE	1
2	100-0917	ROTISSERIE GAS LINE EXTENSION - 3/8"Ø X 8" - SS	1
3	100-0917	SEAR ZONE™ GAS LINE (8"L x 3/8" Ø - SS. FLEX TUBE)	1
4	100-1067	ALX2- SMOKER & SZ™ ORIFICE BRACKET	1
5	100-1949	ROTISSERIE GAS LINE (36"L x 3/8" Ø - SS. FLEX TUBE)	1
6	200-0274	ELBOW 90°- CAST IRON - 1/2" FPT x 1/2" MPT	1
7	220-0151	COUPLING 3/8" x 3/8" - COMPRESSION - BRASS	1
8	220-0273	ELBOW 90° - 1/8" FPT x 3/16" COMP	1
9	220-0275	NIPPLE - 1/2" MPT X 3/8" OD FL	1
10	220-0276	ELBOW 3/8" MPT x 1/8" FPT x 3/8" COMP	1
11	220-0277	NIPPLE 1/8"MPT x 1/16"MPT	1
12	220-0280	REGULATOR GAS - MAXITROL RV48CL440002	1
13	220-0293	ELBOW 3/8-27 UNS x 3/8" COMP	1
14	220-0321	ALX2-30 30SZ GAS MANIFOLD PIPING	1
15	290-0041	GAS VALVE - STRAIGHT - WITHOUT ORIFICES	2
16	290-0066	GAS VALVE - ANGLED - ORIFICE: INT= 0.95 mm / EXT=NONE	1
17	290-0433	ALFRESCO - BBQ KNOB	3
18	290-0434	ALFRESCO -ROTISSERIE / SEAR ZONE™ KNOB	1
19	SEE NOTE	GAS VALVE - ANGLED WITH ORIFICE >>> SEE NOTE	2
20	SEE NOTE	ORIFICE - IR ROTISSERIE UNIT (SEE NOTE FOR SIZING)	1
21	SEE NOTE	ORIFICE - SEAR ZONE™ >>> SEE NOTE	1

NOTE: ORIFICE OR VALVE ASSEMBLY TO CHANGE ACCORDING TO FUEL SUPPLY: NATURAL GAS OR LIQUID PROPANE

ITEM	NG GAS	LP GAS
	PART #	PART #
19	290-0310	290-0311
20	220-0285	220-0286
21	220-0289	220-0290

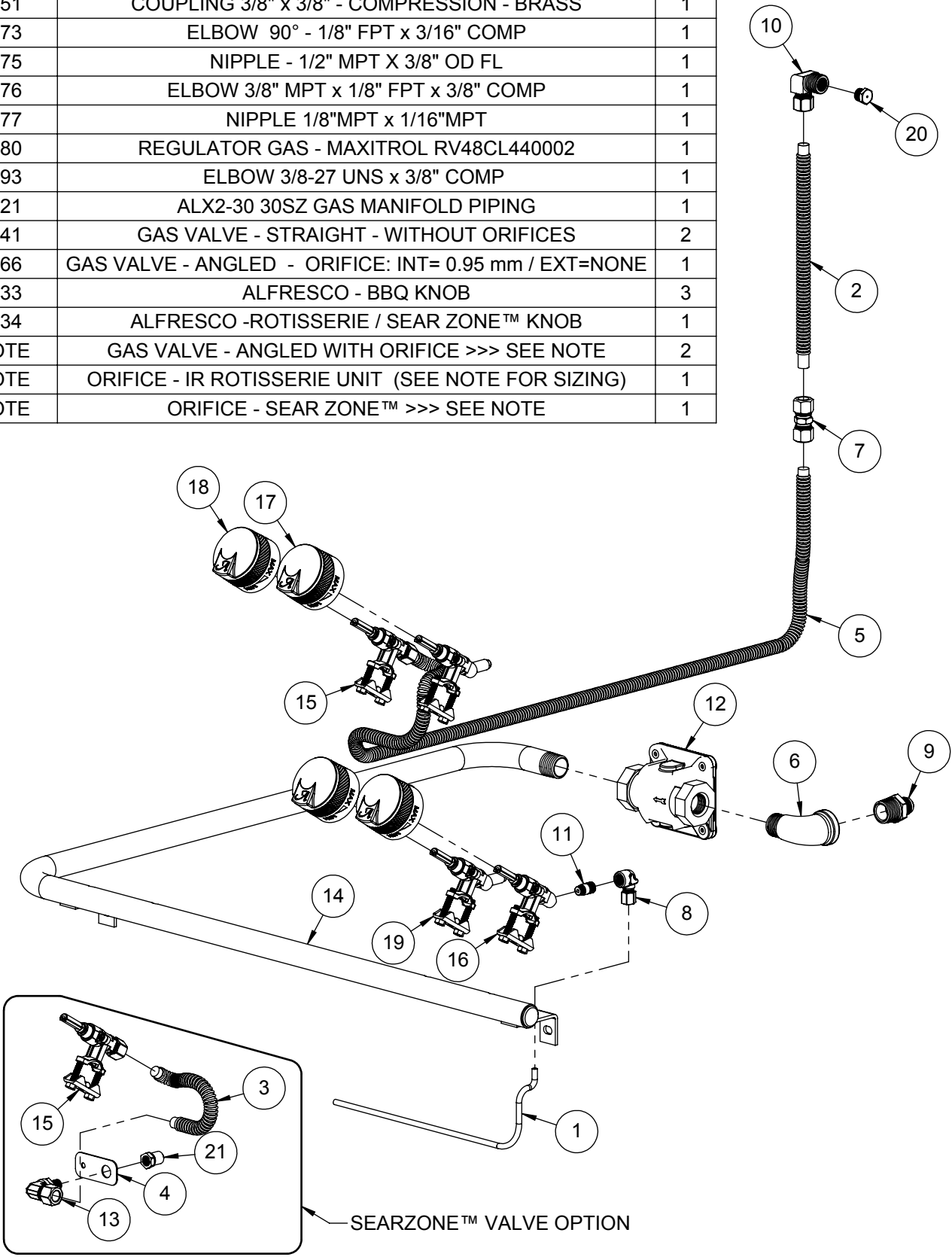

ITEM	PART NUMBER	DESCRIPTION	QTY
1	130-3019	MOUNTING BRACKET	1
2	200-0111	SCREW 8-18 X 1/2 - SELF TAP - 410 SS	3
3	210-0189	ELECTRODE - "L" SHAPED - MAIN BURNER	1
4	220-0273	ELBOW 90° - 1/8" FPT x 3/16" COMP	1
5	510-0504	ALX2 - SMOKER BURNER ASSEMBLY	1
6	SEE NOTE	ORIFICE - SMOKER UNIT >>> SEE NOTE	1

NOTE: ORIFICE OR VALVE ASSEMBLY TO CHANGE ACCORDING TO FUEL SUPPLY: NATURAL GAS OR LIQUID PROPANE

ITEM	NG GAS	LP GAS
	PART #	PART #
6	220-0313	220-0314

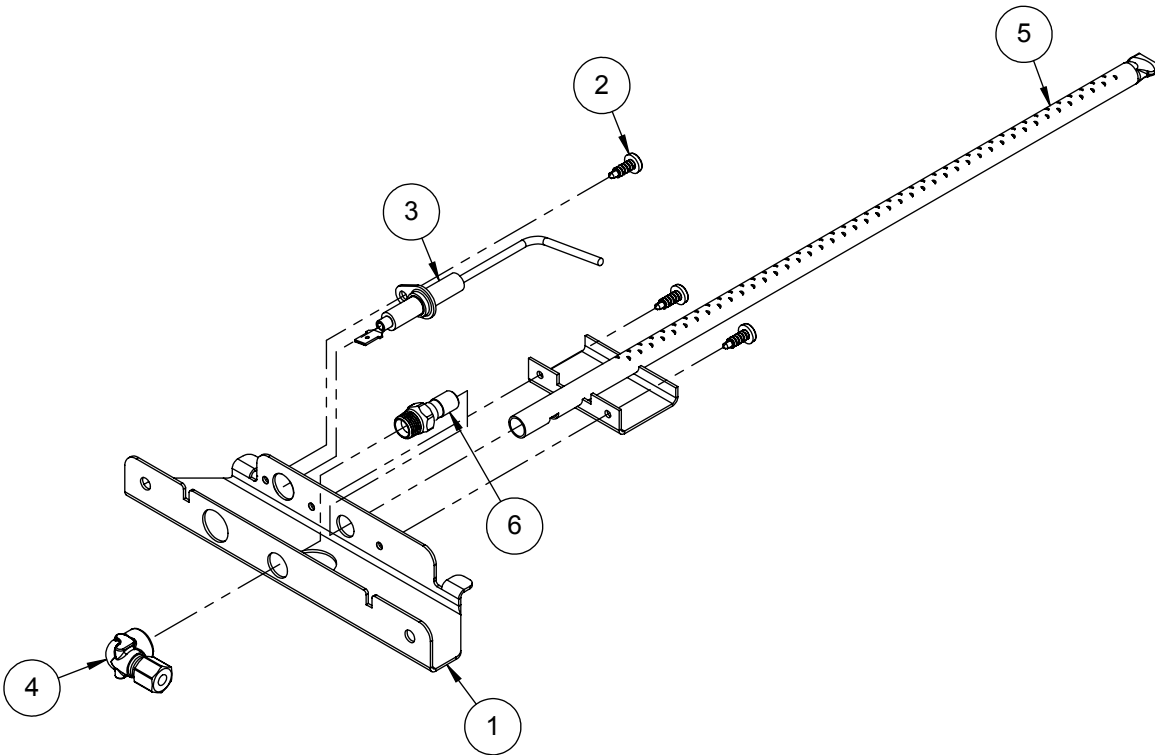

ITEM	PART NUMBER	DESCRIPTION	QTY
1	210-0189	ELECTRODE - "L" SHAPED - U-BURNER / SMOKER	2
2	210-0192	ELECTRODE - DUAL TIP - SEARZONE™	1
3	210-0240	ELECTRODE - DUAL TIP "L" SHAPE- ROTISSERIE	1
4	210-0465	IGNITER MODULE (4 POINTS)	1
5	210-0509	LAMP ASSEMBLY (32" WIRE LENGTH)	1
6	210-0510	LAMP ASSEMBLY (56" WIRE LENGTH)	1
7	210-0520	ALX2-30 / 30SZ - IGNITER WIRE KIT	1
8	210-0626	ALXE PERIMETER LIGHT SWITCH	1
9	510-0514	ALX2 - ROTISSERIE MOTOR BOX ASSEMBLY	1

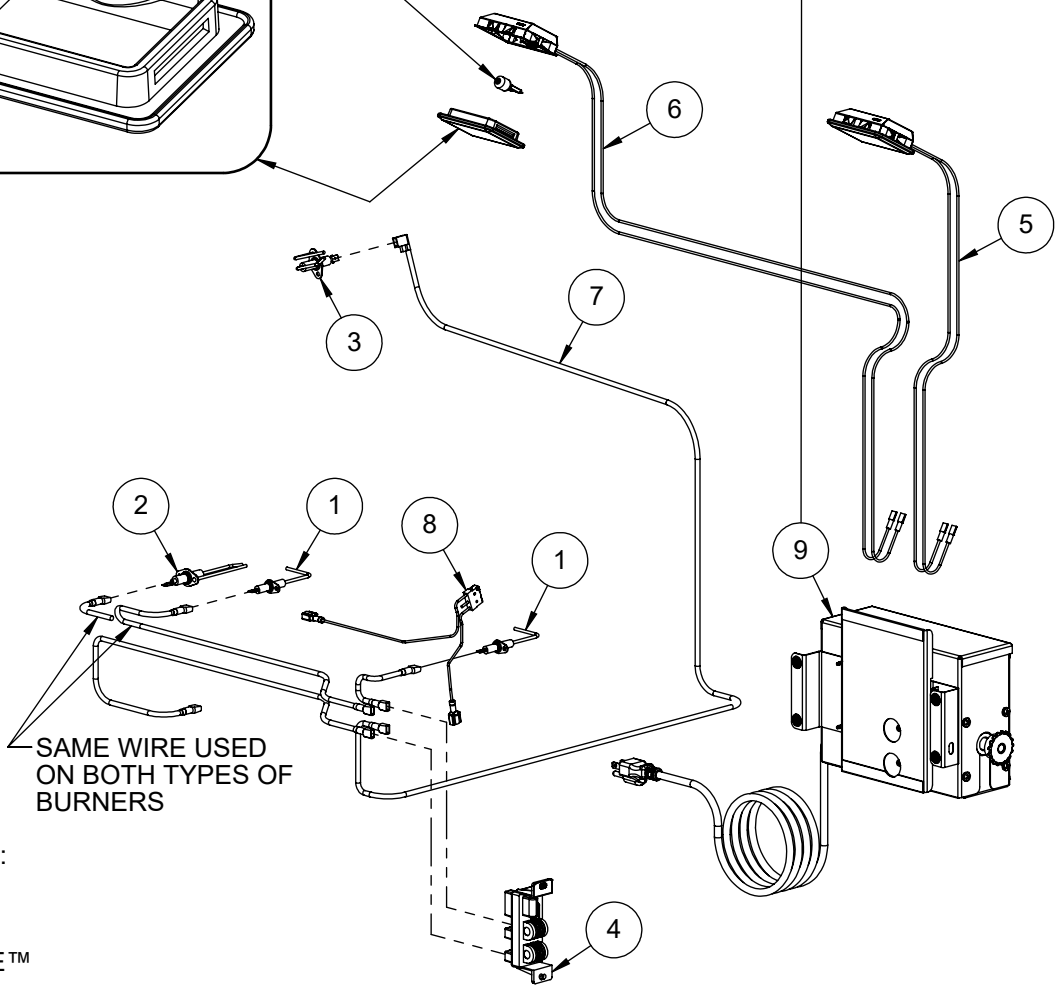
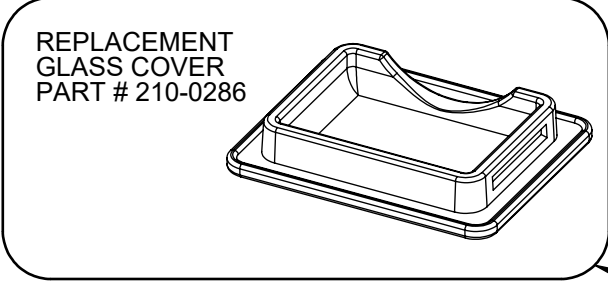
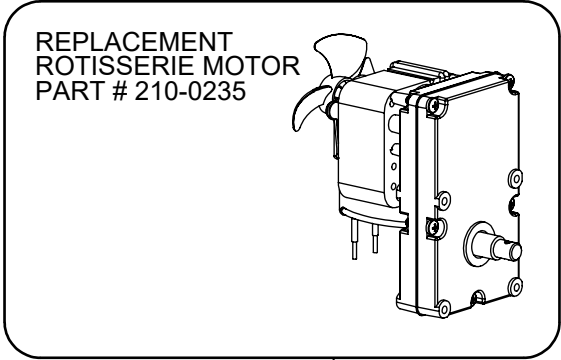
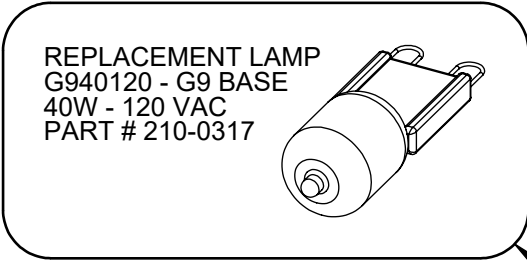

LEFT BURNER ELECTRODE:

- ① USED ON U-BURNER
- ② USED ON SEAR-ZONE™

SAME WIRE USED ON BOTH TYPES OF BURNERS

CONNECTIONS: NEUTRAL TO TRANSFORMER,
POWER TO TRANSFORMER AND IGNITER, LIGHTS
& ROTISSERIE. FRONT LEFT

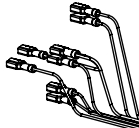

CONNECTIONS IN
MOTOR BOX AT
REAR RIGHT.



CONNECTIONS: IGNITER NEUTRAL & POWER,
PERIMETER LIGHT SWITCH NEUTRAL & POWER,
AND POWER TO TRANSFORMER. FRONT RIGHT.

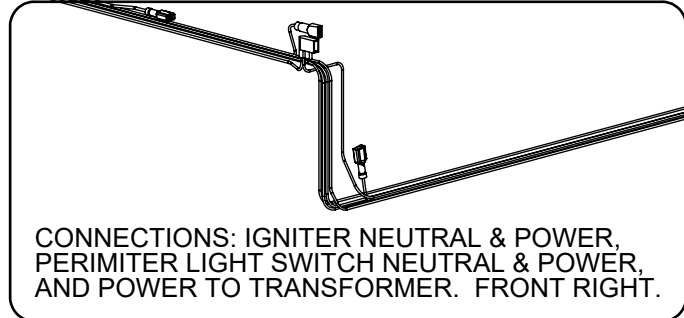

WIRING HARNESS PART NUMBER 210-0598

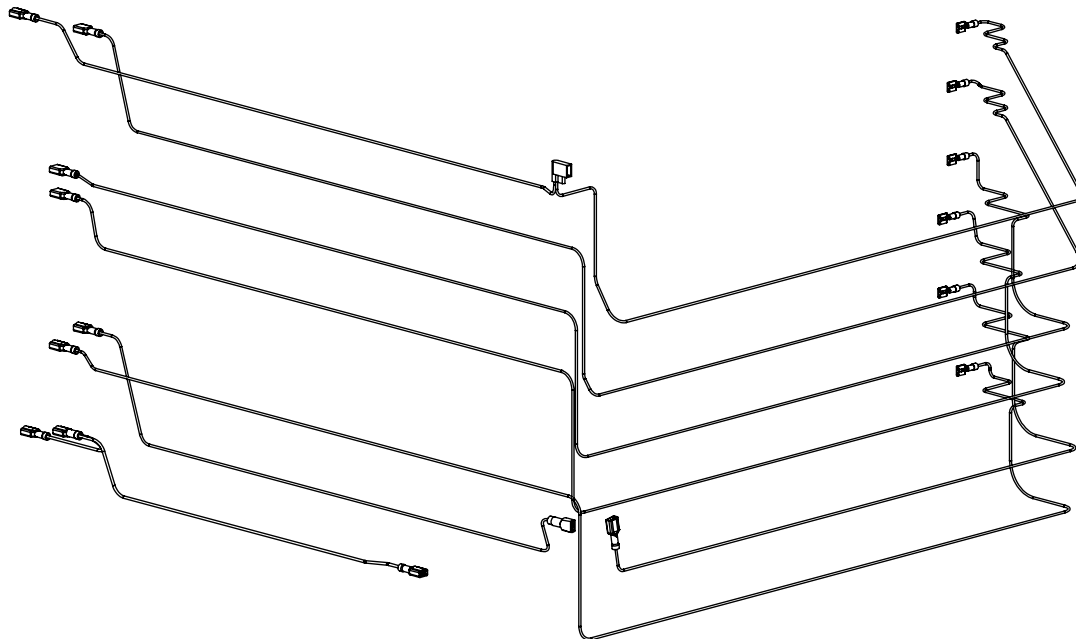

EXPLODED VIEW OF WIRING HARNESS
NOTE: INDIVIDUAL WIRES ARE NOT SOLD SEPARATELY

Alfresco[™]

Open Air Culinary Systems

ALXE-30 PARTS MANUAL

ALFRESCO™ GOURMET GRILLS

ALL RIGHTS RESERVED 02/2016