



Outdoor Grilling Products

Vertical 18" Charcoal Smoker

Models COS-118

ASSEMBLY AND OPERATING INSTRUCTIONS



⚠ WARNING: FOR OUTDOOR USE ONLY

- ⚠ This instruction manual contains important information necessary for the proper assembly and safe use of this smoker
- ⚠ Read and follow all warnings and instructions before assembling and using the smoker
- ⚠ Follow all warnings and instructions when using the smoker
- ⚠ Keep this manual for future reference

Note to installer: Leave this Owner's Manual with the consumer after delivery and/or installation.

Note to customer: Leave this Owner's Manual in a convenient place for future reference.

⚠ DANGER – CARBON MONOXIDE HAZARD

Do Not Use Indoors! Do Not Use Indoors! Burning charcoal releases carbon monoxide gas. If used indoors or in a poorly ventilated area, the gas can accumulate and cause serious injury or death.

⚠ DANGER

Do not use gasoline, alcohol or other flammable liquids to light charcoal. Use only charcoal lighter fluid following the manufacturer's instructions.

⚠ DANGER

Failure to follow these instructions could result in fire, explosion or burn hazard, which could cause property damage, personal injury or death.

⚠ DANGER

1. Never operate this smoker unattended.
2. Never operate this smoker within 10 feet (3.05m) of any flammable material
3. Never operate this smoker with 25 feet (7.5m) of any flammable liquid.
4. If a fire should occur, keep away from the smoker and immediately call your fire department . Do not attempt to extinguish an oil or grease fire with water.

⚠ DANGER

Failure to follow these instructions could result in fire, explosion or burn hazard, which could cause property damage, personal injury or death.

Table of Contents

1. Warnings and Safety Instructions	2 – 3
2. Illustrated Parts List and Exploded View Diagram	4
3. Assembly Instructions	6
4. Operating Your Smoker	
4.1 Select a Proper Location	8
4.2 Choosing Your Charcoal	8
4.3 Air Vent Operation	8
4.4 Lighting Instructions	8
4.5 Operating the Smoker	10
4.6 When Finished Smoking	10
5. Warranty	11

1. Warnings and Safety Instructions

If these instructions are ignored, there is a possibility of a hazardous fire or explosion which could result in physical injury or property damage! It is your responsibility to assemble, operate and maintain your smoker properly.

READ ALL WARNINGS AND INSTRUCTIONS PRIOR TO ASSEMBLING AND OPERATING YOUR SMOKER

⚠ WARNINGS

- ⚠ This smoker is for outdoor use only. It should NOT be used in a building, garage or any other enclosed area.
- ⚠ The use of alcohol, prescription or non-prescription drugs may impair an individual's ability to properly assemble or safely operate this smoker.
- ⚠ Do not leave the smoker unattended.
- ⚠ Keep children and pets away from the smoker all the times.
- ⚠ Do not use the smoker in high wind.
- ⚠ Do not use gasoline, kerosene or alcohol for lighting. Use only charcoal lighter fluid. Follow manufacturer's instructions.
- ⚠ Do not add charcoal lighter fluid or charcoal impregnated with charcoal lighter fluid to hot or warm charcoal.
- ⚠ Do not remove ashes until all charcoal is completely burned out or completely extinguished.
- ⚠ Open the lid while lighting and getting charcoal started.
- ⚠ Always put charcoal on top of the charcoal grate and not directly into the bottom bowl.
- ⚠ Use grill mitts or hot pads to protect hands while adjusting smoker vents.
- ⚠ To extinguish coals do not use water. Close vents and lid and wait until smoker cools below 115° F (45°C).
- ⚠ Handle and store hot electric starters carefully. Never use charcoal lighter fluid or charcoal impregnated with charcoal lighter fluid with an electric starter. Follow electric starter manufacturer's instructions carefully.
- ⚠ When using lighter fluid always check ash collector before lighting . Fluid can accumulate in the ash collector, resulting in a fire below the bottom bowl. Remove any fluid from ash collector prior to lighting.
- ⚠ Do not attempt to move the smoker when in use. Allow the smoker to cool to 115 F°(45 C°) before moving or storing.
- ⚠ Do not use the smoker unless it is COMPLETELY assembled and all parts are securely fastened and tightened. If there are any missing or damaged parts, contact customer service for a replacement.
- ⚠ Do not alter the smoker in any manner.
- ⚠ This smoker is not intended to be installed in or on a boat or recreational vehicle.
- ⚠ Locate the smoker away from any combustible materials or construction by at least 10 feet in all directions. Never use smoker under any overhang or enclosure.
- ⚠ This smoker is not intended for and should never be used as a heater.
- ⚠ This smoker will be hot during and after use. Use insulated oven mitts or gloves for protection from hot surfaces or splatter from cooking liquids.
- ⚠ This smoker is not intended for commercial use.
- ⚠ Combustion by-products produced when using this product contain chemicals known to the state of California to cause cancer, birth defects, or other reproductive harm.

2. Illustrated Parts List and Exploded View

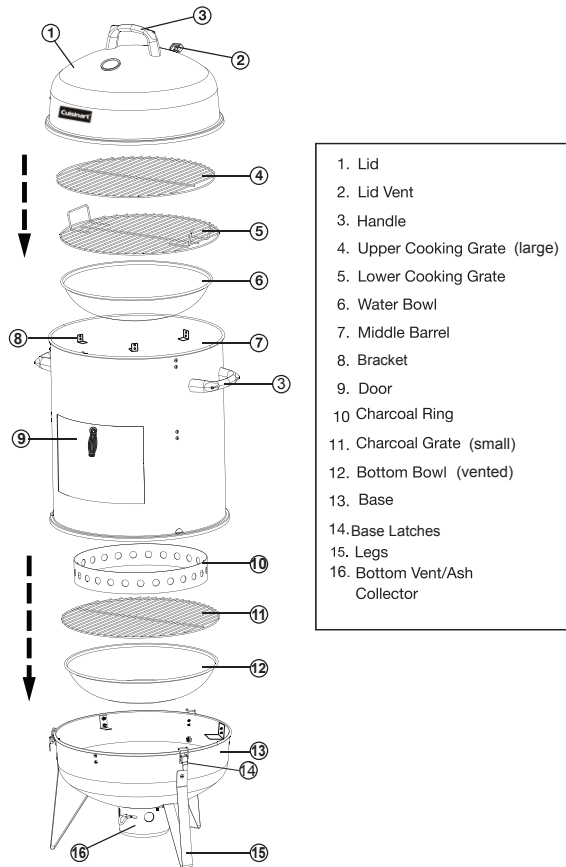

North American Distributor: The Fulham Group, Newton, MA 02466

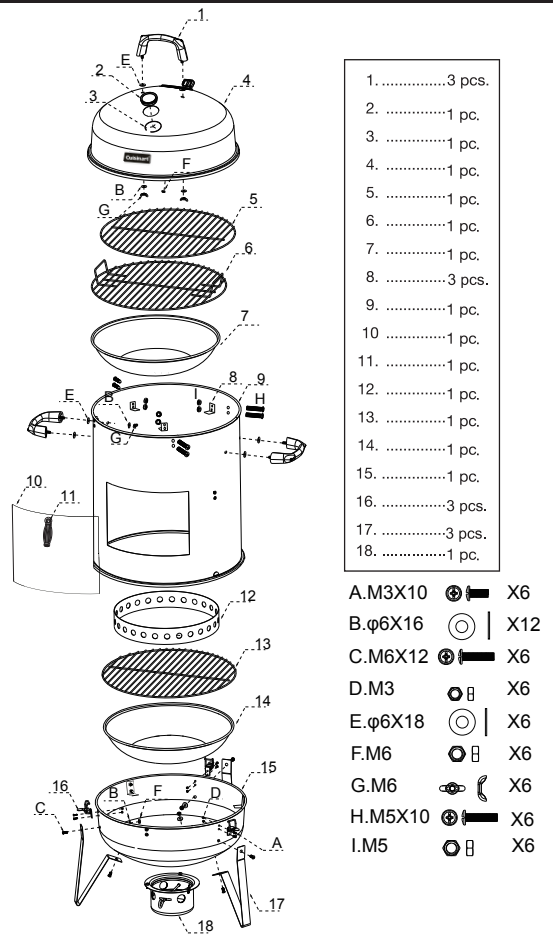

3. Assembly Instructions

Remove all the contents from packaging, and make sure all parts are present before attempting to assemble!

Step 1:

Assemble Legs

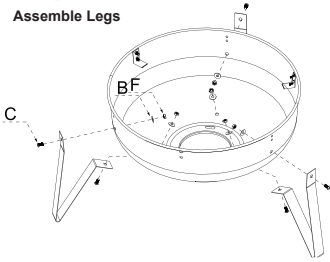

Step 2:

Attach Bottom Vent by lifting vent up to base and lining screws up with circular openings. Rotate vent to lock in place. Screw in Base Latches

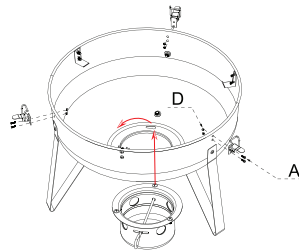

Step 3:

Attach Handles to Middle Barrel. Attach upper three brackets to Middle Barrel.

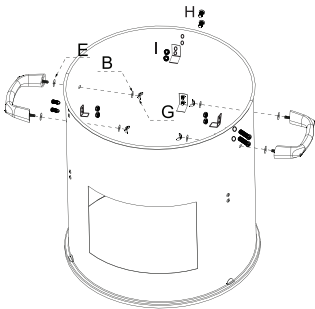

Step 4:

Attach Door by tilting it at a 45° angle with the handle facing out. Place one side of the Door through the Middle Barrel at a time in order to secure in place.

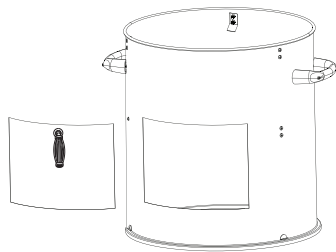

Step 5:

Attach handle to lid

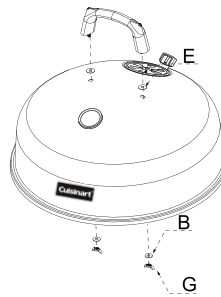

Step 6:

Assemble smoker according to diagram. Water Bowl rests on lower three brackets of Middle Barrel. Lower Cooking Grate rests on Water Bowl

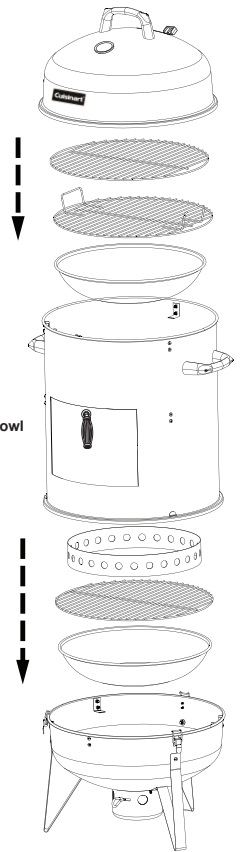

4. Operating Your Smoker

4.1 Select a Proper Location

Once you have assembled your new smoker, find a suitable location for use.

⚠ DANGER

- Never use this outdoor smoker inside any building, garage, shed or breezeway, under an overhang or inside any boat, trailer or recreational vehicle, to prevent possible fire and to prevent the possibility of carbon monoxide poisoning or asphyxiation.
- Always place your smoker on a hard and level surface far away from combustible materials and structures.
- Do not use this smoker under overhead combustible surface or covered area (e.g., awnings, umbrellas, porches or gazebos). Keep all combustible surfaces at least 10 feet (3 meters) away.
- Locate the smoker away from any combustible and non-combustible material or construction by at least 10 feet (3m)
- Never store or use gasoline or other flammable or volatile substances in the vicinity of this smoker or in the vicinity of any other heat-generating appliance, because of the danger of starting a fire.
- Do not obstruct the flow of combustion and ventilation air.

4.2 Choosing your charcoal

- We recommend using charcoal briquettes or lump charcoal.
- Adding 3 or 4 lumps of dry hard wood on top of hot coals can provide added smoke flavor.

4.3 Air Vent Operation

Your smoker has two airflow control vents; a bottom vent below the bottom bowl and an air exhaust vent at the top of the lid. By adjusting the amount of vent opening, you can adjust the temperature of your smoker.

⚠ DANGER

- The vents and vent controls and the metal surfaces around them will become very hot during smoker use. Use grill mitts or hot pads to adjust vents when smoker is in use.

4.4 Lighting instructions

⚠ DANGER

- Do not use gasoline, kerosene or alcohol for lighting. Use only charcoal lighter fluid. Follow manufacturer's instructions.
- Do not add charcoal lighter fluid or charcoal impregnated with charcoal lighter fluid to hot or warm charcoal.
- Do not overfill charcoal grate. Excess charcoal may cause a fire, or may cause damage to your smoker.

1. Read all instructions before lighting.
2. Leave middle barrel off during charcoal lighting and heat up period
3. Carefully follow all instructions accompanying charcoal lighter fluid, electric charcoal starters, and or charcoal.
4. Fully open air vents on lid and bottom vent.

4. Operating Your Smoker

5. Ensure that the charcoal grate is in the smoker, and positioned properly
6. Ensure that the bottom bowl is empty (NEVER remove hot ashes; follow ash removal instructions in section 4.6)
7. Open both vents as described in section 4.3
8. Place desired amount of charcoal onto charcoal grate. Use no more than will go above the brim of the charcoal ring. Overfilling the charcoal ring with charcoal can cause injury and damage your smoker.

ELECTRIC STARTER

- Follow electric starter manufacturer's instructions
- Use caution when removing hot starter

CHIMNEY STARTER

- 1 For best results with a chimney starter, remove cooking grate and set aside.
- 2 Put desired amount of charcoal in chimney starter
- 3 Place crumpled newspaper under the starter and light, being sure to follow the starter manufacturer's instructions
- 4 Carefully pour ignited coals onto charcoal tray, using mitts, gloves, eye protection, and any other protective equipment recommended by the starter manufacturer.
- 5 Replace cooking grate using a grilling mitt or grate lifting tool.

SELF STARTING CHARCOAL

⚠ DANGER

- Do not add charcoal lighter fluid or charcoal impregnated with charcoal lighter fluid to hot or warm charcoal.
- Arrange desired amount of charcoal and ignite following manufacturer's instructions

LIGHTER FLUID

⚠ DANGER

- Follow all instructions on lighter fluid container.
- When using lighter fluid always check ash collector before lighting. Fluid can accumulate in the ash collector, resulting in a fire below the bottom bowl. Remove any fluid from ash collector prior to lighting.
- Do not add charcoal lighter fluid or charcoal impregnated with charcoal lighter fluid to hot or warm charcoal.

- 1 Place desired coals onto charcoal grate. Arrange as indicated by lighter fluid manufacturer
 - 2 Following lighter fluid manufacturer instructions, apply lighter fluid to charcoal
 - 3 Be sure to allow all lighter fluid to burn off prior to cooking, or noticeable flavors can be added to food
- *Clean your smoker after each use. DO NOT use abrasive or flammable cleaners, as it will damage the parts of this product and may start a fire. Clean with warm soapy water.

4. Operating Your Smoker

4.5 Operating the Smoker

- Latch the middle barrel to the bottom bowl
- Place the water bowl on the latches inside the middle barrel
- Fill the water bowl to desired fullness level (recommended halfway to full)
- Place lower cooking grate on top of water bowl
- For larger foods that need extra space-place food on lower cooking grate. For ease of access or smoking smaller foods-use upper cooking grate.
- Secure lid on middle barrel
- Average smoking temperature is approximately 225° F. Open vents to increase smoker temperature. Close vents to decrease smoker temperature. Vents may need to be adjusted throughout smoking process.

*TIPS

- The water in the smoker is used to keep the temperature low. Check the water level every couple hours. If you notice the temperature going up in the smoker, add desired amount of water.
- We don't recommend opening the door often, but it provides access to bottom bowl charcoal/wood. chunks and lower cooking grate when necessary.
- External thermometer probes can run through the lid vent to access food in smoker.

4.6 When Finished Cooking

DANGER

- **Never use water to extinguish charcoal.**
 - **Do not remove ashes until all charcoal is completely burned out or completely extinguished.**
1. Close lid, and close both vents.
 2. The charcoal will slowly cool.
 3. Once charcoal is cool, slide out ash collector and dispose into a metal container.

5. Warranty

This warranty covers defects in parts and workmanship for a period of 3 years from the original purchase date. Any damage claim regarding the enameling must be submitted within 30 days of purchase to be covered by the warranty.

The following conditions are NOT covered by this warranty:





- Unevenness and color variations in the enamel coating.
- Damage caused by improper assembly or disregard of the manual.
- Use of spare parts not supplied by manufacturer.
- Damage resulting from modifications or inappropriate use.
- Abuse of the smoker
- Damage caused by improper maintenance or repairs by an unauthorized person.

Limitations and exclusions:

1. This warranty applies only to the original purchaser and may not be transferred.
2. If you cannot verify the purchase date of the smoker the warranty period will begin on the date the smoker was manufactured.
3. Replacement or repair parts are warranted for the remaining period of the original part warranty.

Your obligations:

This smoker must be assembled, installed, operated and maintained in accordance with all applicable codes and the instruction manual furnished with this smoker. You must keep an invoice, cancelled check or payment record to verify the purchase date of the smoker.

 WARNING 	 AVERTISSEMENT 
CALIFORNIA PROPOSITION 65 1. Combustion by-products produced when using this product contain chemicals known to the State of California to cause cancer, birth defects, and other reproductive harm. 2. This product contains chemicals, including lead and lead compounds, known to the State of California to cause cancer, birth defects or other reproductive harm. <i>Wash your hands after handling this product.</i>	PROPOSITION 65 DE CALIFORNIE 1. Les sous-produits de combustion libérés au cours de l'utilisation de cet appareil contiennent des produits chimiques réputés dans l'État de la Californie comme pouvant causer le cancer, des anomalies congénitales et présentant d'autres dangers pour la reproduction. 2. Cet appareil renferme des produits chimiques, y compris du plomb et des composés du plomb, reconnus dans l'État de Californie comme étant susceptibles de causer le cancer, des anomalies congénitales, ou autres dangers pour la reproduction. <i>Lavez-vous les mains après avoir manipulé cet appareil.</i>

 ADVERTENCIA 
PROPOSICION 65 DEL ESTADO DE CALIFORNIA 1. En el estado de California se sabe que los subproductos de la combustión, que se producen al usar este producto, contienen sustancias químicas que causan cáncer, defectos congénitos u otras lesiones al aparato reproductor. 2. Este producto contiene sustancias químicas, incluyendo el plomo y compuestos de plomo, que en el estado de California se sabe que las causan cáncer, defectos congénitos u otras lesiones al aparato reproductor. <i>Lávese las manos después de manipular este</i>

For customer service please call, email, or write:

1-866-994-6390

North American Distributor:
The Fulham Group
130 Rumford Ave.
Newton, MA 02466

www.cuisinart.com | grilling@thefulhamgroup.com

Model # COS-118