

This Owner's Manual is provided and hosted by [Appliance Factory Parts](#).



Alfresco ALX242SZ Owner's Manual

[Shop genuine replacement parts for Alfresco
ALX242SZ](#)



[Find Your Alfresco Grill Parts - Select From 126 Models](#)

----- Manual continues below part list -----

Available Replacement Parts for Alfresco ALX242SZ

290-0052	INFRARED SEARING BURNER
290-0030	Knob for Alfresco
265-0005	CERAMIC BRIQUETTES(24 pcs)
210-0189	L SHAPED ELECTRODE
290-0059	ROTISSERIE DRIP PAN
290-0063	HANDLE-END CAP ASSEMBLY.
100-0917	GAS LINE 8 IN L X 3/8 IN DIA FLEX SS TUB
220-0273	ELBOW 90 DEGREE
220-0277	NIPPLE
220-0280	REGULATOR-GAS
290-0041	GAS VALVE, STRAIGHT, NO ORIFICE
290-0066	VALVE GAS-ANGLED
290-0096	FORK ASSEMBLY (PAIR)
290-0116	CHAIN-ANSI 25-1/4 PITCH-.13 ID X 1/8 ROL
290-0124	GRILL 30 IN BBQ-12 3/4 IN WIDE-SS
290-0157	cooking grid for grill 30 in bbq
290-0158	SPEAR- ROTISSERIE
200-0148	SCREW 10-32 X 3/4 FLAT HEAD PHILIPS 82 D
290-0119	ROLLER WHEEL-STAINLESS STEEL-3/4 IN DIA
510-0139	ROTISSERIE GEAR ASSEMBLY.
220-0341	MANIFOLD 42 IN BBQ-2006 MODEL.
220-0290	ORIFICESEAR ZONE-LP.
210-0192	ELECTRODE
210-0198	SWITCH-WEATHER BOOT AND CAP
210-0240	ELECTRODE-DUAL TIP IR BURNERS.
210-0286	REPLACEMENT GLASS
12541	burner, center-fed pipe, ss, 18.125 x 7.
210-0571	THERMOMETER
510-0504	SMOKER BURNER
100-1846	U-burner bracket

100-1848	IGNITER BRACKET
290-0311	GAS VALVE
100-1847	SEAR-ZONE IGNITER BRACKET
510-0522	Briquette Tray Assy
210-0317	LAMP 40W
210-0466	IGNITER MODULE
100-1894	BRIQUETTE TRAY BASE .
100-1895	BRIQUETTE LOCK BAR.
210-0509	LAMP ASSEMBLY 32 IN. WIRE.
210-0510	LAMP ASSEMBLY 56 IN WIRE.
210-0508	Igniter switch on/off

TM

AlfrescoTM

Open Air Culinary Systems



ALX2-42 / 42SZ Parts Manual

For models S/N: 11-00000 forward.

BILL OF MATERIALS

ITEM	PART N°	DESCRIPTION	QTY
1	100-1877	ALX2 - ROTISSERIE CHAIN COVER	1
2	200-0057	SCREW 1/4-20 X 1/2 - TRUSS HEAD - PHILPS	12
3	200-0087	WASHER - 1/4" SPRING LOCK- REGULAR - SS	9
4	200-0089	BOLT - HEX HEAD 1/4-20 x 1/2" L	5
5	200-0093	WASHER - PUSH LOCK 1/8" ID X 3/8" OD (LOGO)	2
6	200-0111	SCREW 8-18 X 1/2 - SELF TAP - 410 SS	3
7	200-0219	HEX HD MACHINE SCREW 1/4-20 UNC X 5/8 LONG SS	4
8	200-0244	WASHER, FLAT 1/4 TYPE B - REGULAR, SS	4
9	290-0031	LOGO - ALFRESCO	1
10	290-0038	BURNER - GRILL - "U" SHAPE	3
11	290-0052	ALFRESCO SEAR ZONE™ BURNER ASSEMBLY	1
12	290-0059	ROTISSERIE DRIP PAN	1
13	290-0096	FORK ASSEMBLY	2
14	290-0116	CHAIN - ANSI # 25 - 1/4" PITCH - .13" Ø X 1/8" ROLLER	1
15	290-0124	GRILL 30" BBQ - 12 3/4" WIDE - SS	2
16	290-0157	GRILL 30" BBQ - 11 1/4" WIDE - SS	1
17	290-0158	SPEAR - ROTISSERIE - 42" - 2006 BBQ	1
18	290-0304	ALX2-42 WARMING RACK - SS	1
19	510-0131	ALX2-42 / 42SZ SZ - GAS MANIFOLD ASSEMBLY	1
20	510-0495	ALX2-42 / 42SZ - ELECTRICAL COMPONENTS	1
21	510-0500	ALX2-42 BBQ - FIRE BOX ASSEMBLY	1
22	510-0504	ALX2 - SMOKER BURNER ASSEMBLY	1
23	510-0505	ALX2-42 / 42SZ - GREASE TRAY ASSEMBLY	1
24	510-0506	ALX2-42 - FRONT PANEL MAIN ASSEMBLY	1
25	510-0508	ALX2-42 / 42SZ - BACK HOOD WITH RIM ASSEMBLY	1
26	510-0515	ALX2-42 / 42SZ FRONT HOOD - MAIN ASSEMBLY	1
27	510-0518	ALX2 - SMOKER TRAY ASSEMBLY	1
28	510-0521	ALX2 - SEARZONE™ GRILL ASSEMBLY	1
29	510-0522	ALX2 - BRIQUETTE TRAY ASSEMBLY	3

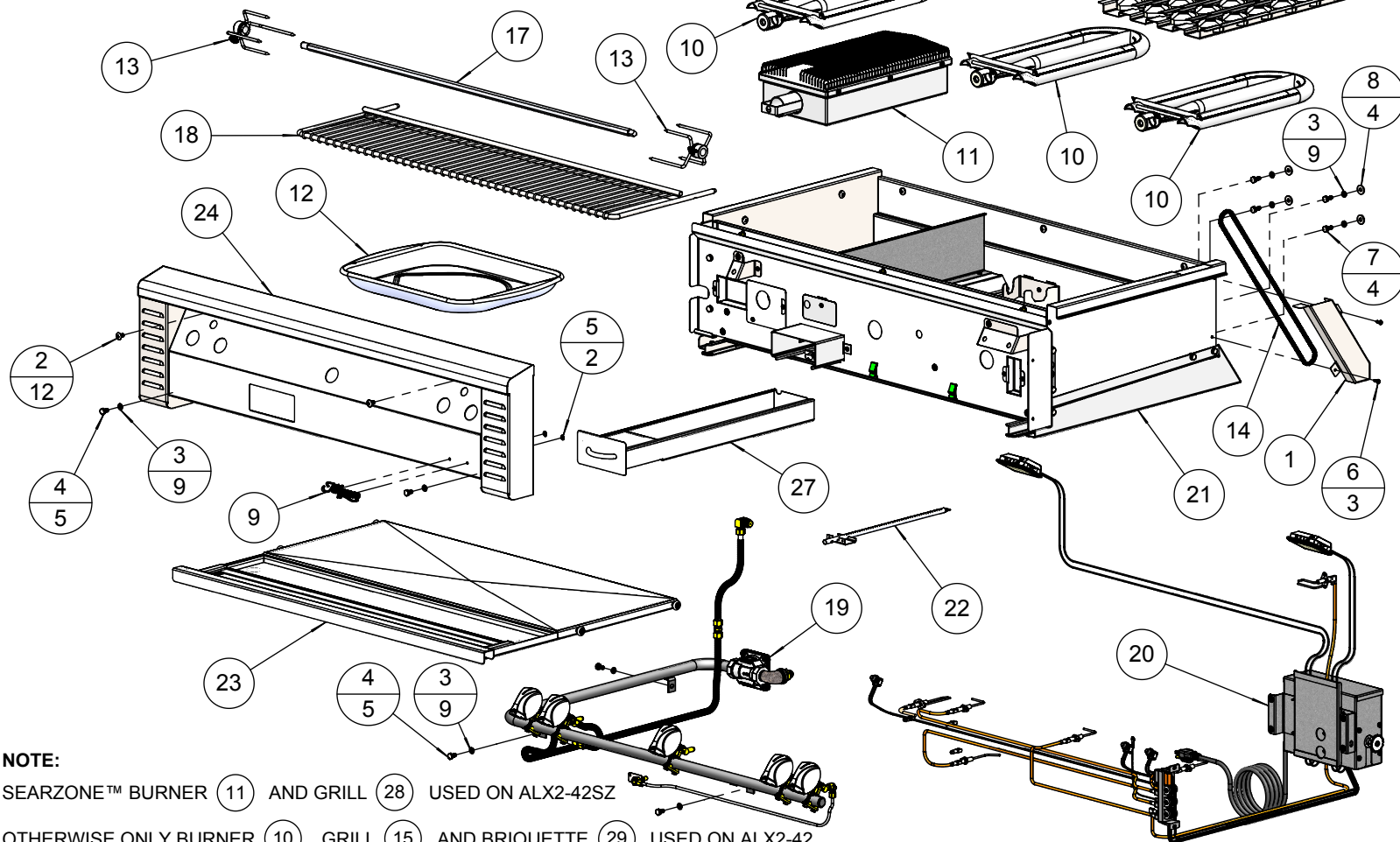
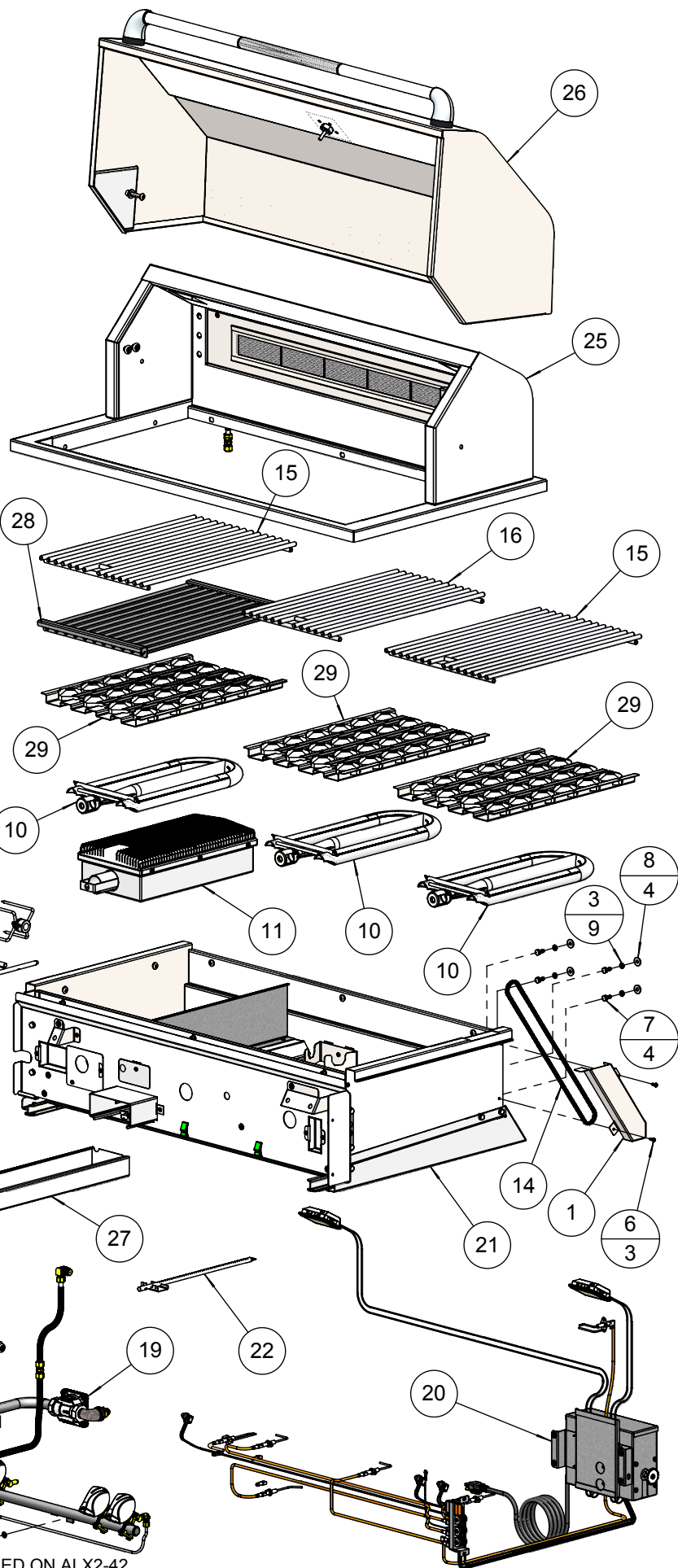

NOTE:
 SEARZONE™ BURNER (11) AND GRILL (28) USED ON ALX2-42SZ
 OTHERWISE ONLY BURNER (10) , GRILL (15) AND BRIQUETTE (29) USED ON ALX2-42.

BILL OF MATERIALS

ITEM	PART N°	DESCRIPTION	QTY
1	210-0189	ELECTRODE - "L" SHAPED - U-BURNER / SMOKER	4
2	210-0192	ELECTRODE - DUAL TIP - SEARZONE™	1
3	210-0198	SWITCH - WEATHER BOOT & CAP	3
4	210-0240	ELECTRODE - DUAL TIP "L" SHAPE- ROTISSERIE	1
5	210-0466	IGNITER MODULE (6 POINTS)	1
6	210-0506	LIGHT SWITCH - [OFF/ ON] TOGGLE	1
7	210-0507	ROTISSERIE SWITCH - [OFF/ ON] TOGGLE	1
8	210-0508	IGNITER SWITCH - [OFF/ ON] MOMENTARY	1
9	210-0509	LAMP ASSEMBLY (32" WIRE LENGTH)	1
10	210-0510	LAMP ASSEMBLY (56" WIRE LENGTH)	1
11	210-0521	ALX2-42 / 42SZ - IGNITER WIRE KIT	1
12	510-0514	ALX2 - ROTISSERIE MOTOR BOX ASSEMBLY	1

REPLACEMENT
ROTISSERIE MOTOR
PART # 210-0235

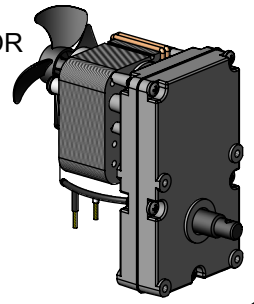

REPLACEMENT LAMP
G940120 - G9 BASE
40W - 120 VAC
PART # 210-0317

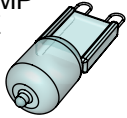

REPLACEMENT
GLASS COVER
PART # 210-0286

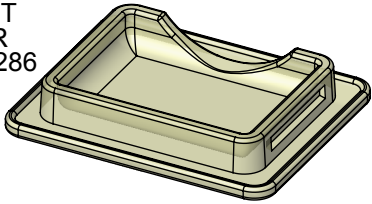

LEFT BURNER ELECTRODE:

- ① USED ON U-BURNER
- ② USED ON SEAR-ZONE™

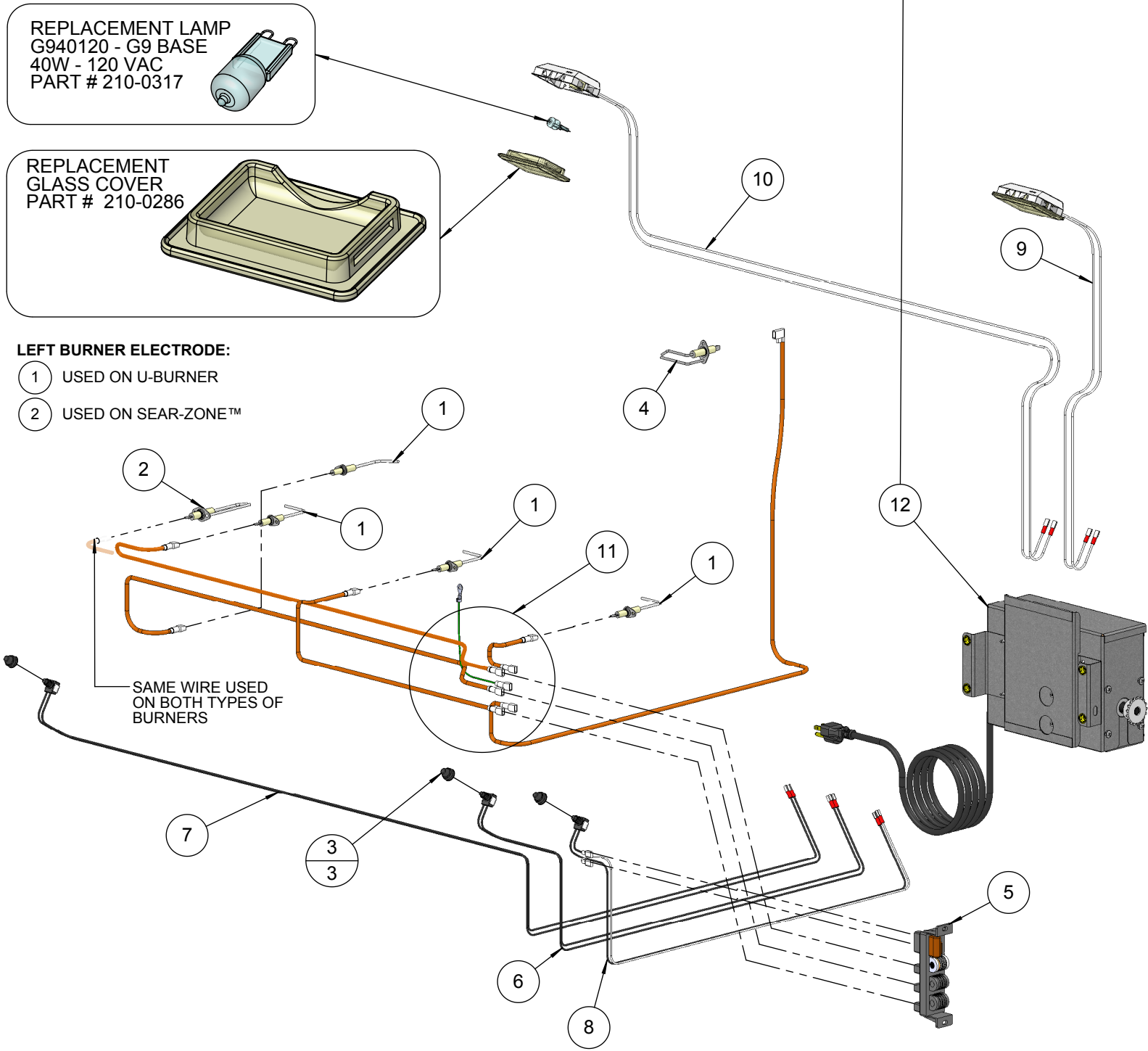

BILL OF MATERIALS

ITEM	PART N°	DESCRIPTION	QTY
1	100-1065	SEARZONE™ OPENING FIREBOX COVER	1
2	100-1831	ALX2 - SMOKER BOX BODY	1
3	100-1833	ALX2 SMOKER BOX TOP DIFUSSER	1
4	100-1846	ALX2 - U-BURNER BRACKET	3
5	100-1847	ALX2 - SEAR-ZONE IGNITER BRACKET / SHIELD	1
6	100-1848	ALX2 - IGNITER SHIELD	3
7	100-1849	ALX2 - IGNITER HOLE COVER	1
8	100-1866	ALX2 - SEAR-ZONE BURNER SHIELD	1
9	100-1884	ALX2 - SEAR-ZONE™ BURNER BRACKET	1
10	100-1887	ALX2 - DUAL VALVE FIREWALL COVE	1
11	100-1888	ALX2 - SINGLE VALVE FIREWALL COVE	1
12	100-1890	ALX2 - FIREWALL OPENING COVER FOR SEARZONE™	1
13	100-1945	ALX2 - DUAL VALVE FIREWALL COVER FOR U-BURNER	1
14	100-1946	ALX2 - FIREWALL OPENING COVER FOR U-BURNER	1
15	200-0087	WASHER - 1/4" SPRING LOCK- REGULAR - SS	17
16	200-0089	BOLT - HEX HEAD 1/4-20 x 1/2" L	17
17	200-0111	SCREW 8-18 X 1/2 - SELF TAP - 410 SS	34
18	200-0305	SPEED NUT TINNEMAN U-TYPE	2
19	510-0501	ALX2-42 FIREBOX - WELDED PARTS	1
20	510-0502	ALX2 - GREASE TRAY SUPPORT - RIGHT SIDE	1
21	510-0503	ALX2 - GREASE TRAY SUPPORT - LEFT SIDE	1
22	510-0507	ALX2 - FRONT PANEL BRACKET ASSEMBLY - SINGLE SWITCH	1
23	510-0517	ALX2 - FRONT PANEL BRACKET ASSEMBLY - DUAL SWITCH	1
24	510-0520	ALX2 - FIREWALL SUPPORT BRACKET ASSEMBLY	2
25	510-0540	ALX2-42 / 42SZ FIREWALL ASSEMBLY	1

NOTE:

BRACKETS USED ON **ALX2-42** MODEL:

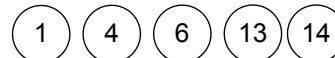

BRACKETS USED ON **ALX2-42SZ** MODEL:

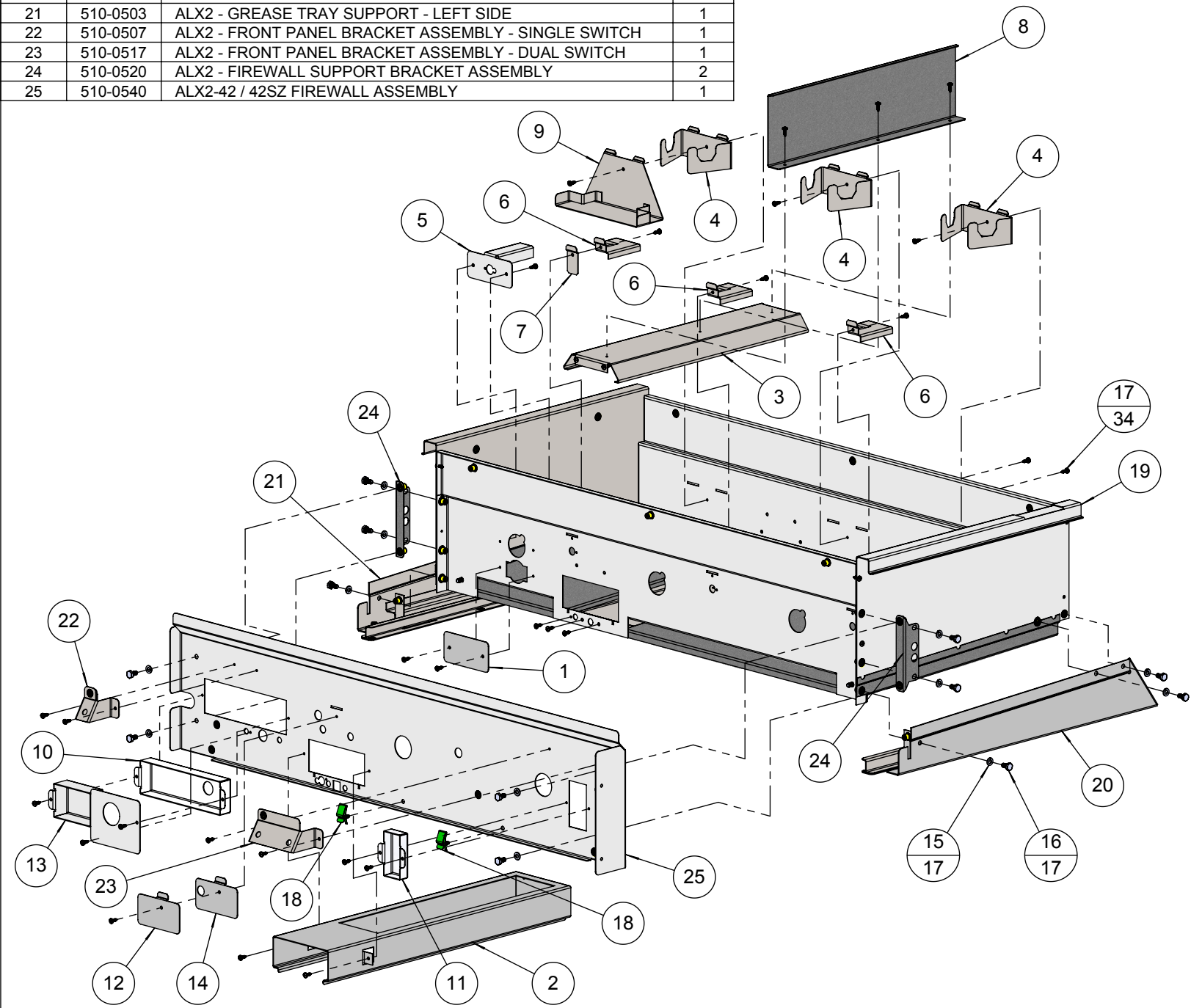

BILL OF MATERIALS

ITEM	PART N°	DESCRIPTION	QTY
1	100-1840	ALX2 - GREASE TRAY REMOVABLE PAN	1
2	200-0148	SCREW 10-32 X 3/4" - FLAT HEAD - PHILIPS - 82° - SS	4
3	290-0119	ROLLER WHEEL - STAINLESS STL - 3/4" Ø -	4
4	510-0499	ALX2-42 GREASE TRAY WELDED PARTS	1

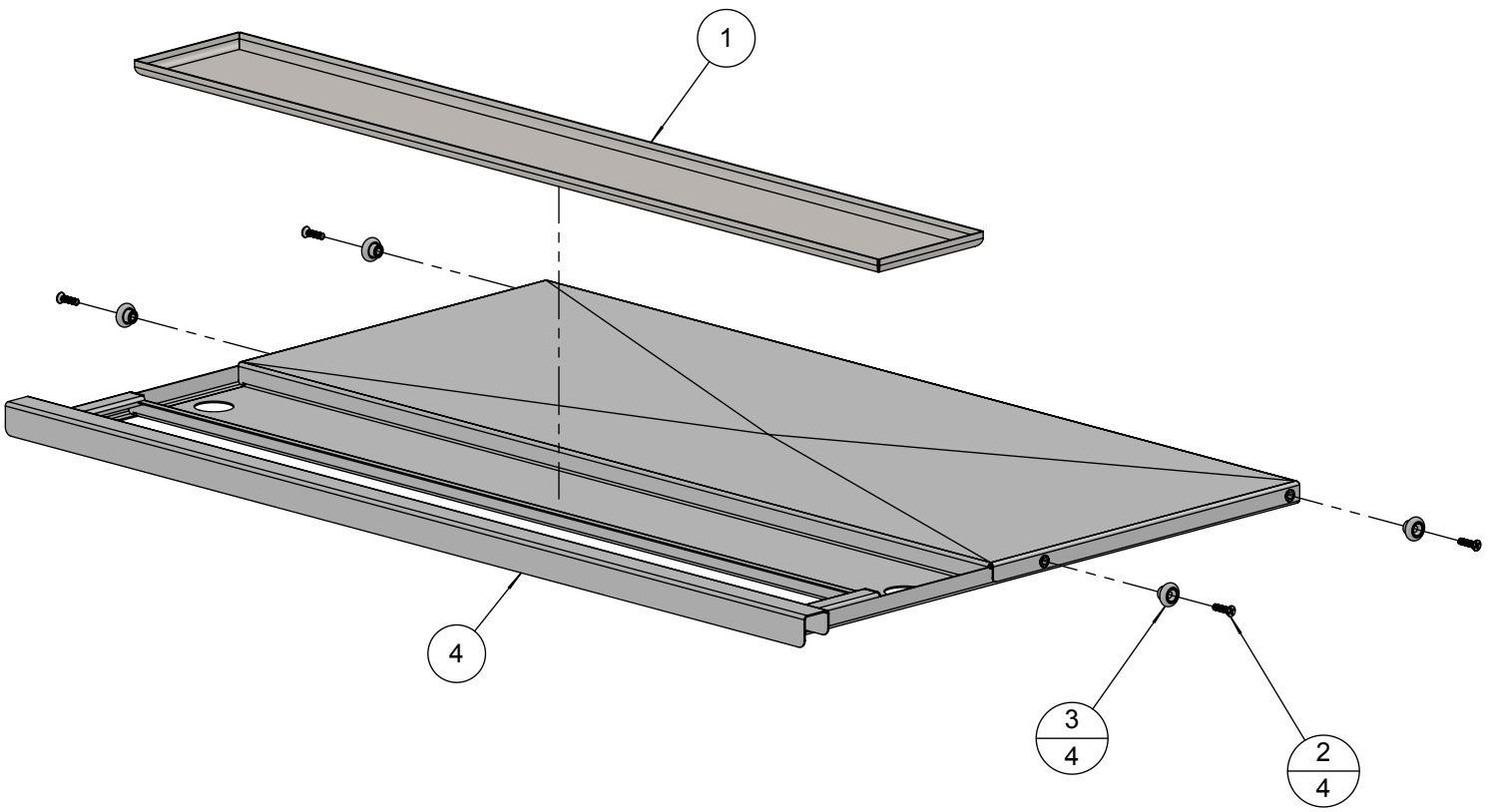

BILL OF MATERIALS

ITEM	PART N°	DESCRIPTION	QTY
1	100-1092	ALX2 - ROTISSERIE GEAR COVER	1
2	200-0062	10-32 X 3/4 - PAN HEAD - PHILIPS SCREW	2
3	200-0086	1/4-20 X 3/8 - TRUSS HEAD - PHILIPS SCREW	2
4	200-0087	WASHER - 1/4" SPRING LOCK- REGULAR - SS	4
5	200-0089	1/4-20 X 1/2 - HEX HEAD BOLT	4
6	200-0111	SCREW 8-18 X 1/2 - SELF TAP - 410 SS	1
7	200-0148	SCREW 10-32 X 3/4" - FLAT HEAD - PHILIPS - 82° - SS	2
8	200-0305	SPEED NUT TINNERMAN U-TYPE	4
9	290-0119	ROLLER WHEEL - STAINLESS STL - 3/4" Ø -	2
10	510-0139	ALX2 - ROTISSERIE GEAR ASSEMBLY	1
11	510-0509	ALX2-42 - BACK HOOD AND RIM - WELDED PARTS	1
12	510-0511	ALX2 - WARMING RACK BRACKET ASSEMBLY - LEFT SIDE	1
13	510-0513	ALX2-42 BBQ - ROTISSERIE PANEL ASSY	1
14	510-0519	ALX2 - WARMING RACK BRACKET ASSEMBLY- RIGHT SIDE	1

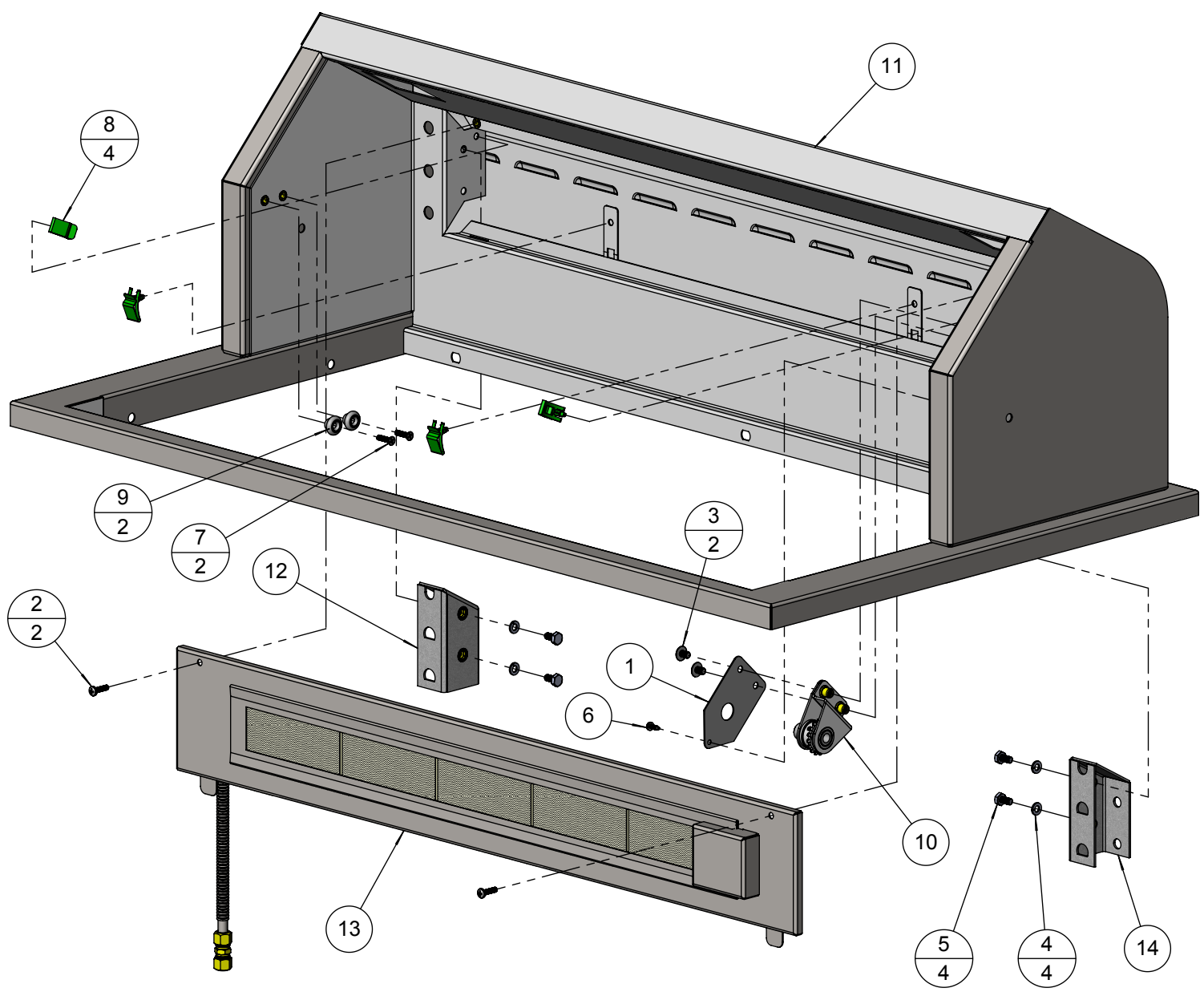

BILL OF MATERIALS

ITEM	PART N°	DESCRIPTION	QTY
1	100-1226	ROTISSERIE ELECTRODE BRACKET	1
2	100-1882	ALX2 - ROTISSERIE ELECTRODE COVER	1
3	200-0111	SCREW 8-18 X 1/2 - SELF TAP - 410 SS	3
4	210-0240	ELECTRODE - DUAL TIP "L" SHAPE- ROTISSERIE	1
5	510-0469	ALX2 - ROTISSERIE PIPING SUBASSEMBLY	1
6	510-0512	ALX2-42 - ROTISSERIE PANEL - WELDED PARTS	1

ELECTRODE SHOWN FOR ASSEMBLY PURPOSE ONLY
REFER TO ASSEMBLY DRAWING 510-0495 FOR ALL
ELECTRICAL COMPONENTS

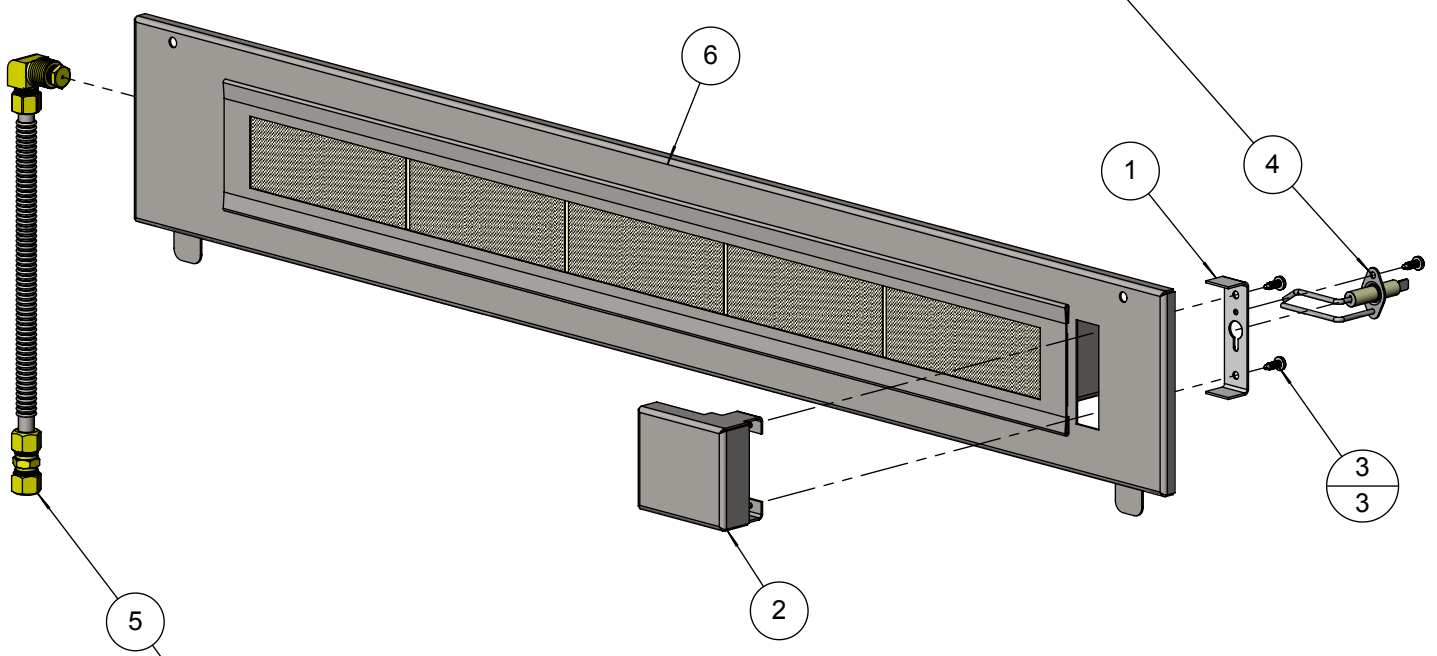

THESE PARTS SHOWN FOR ASSEMBLY PURPOSES ONLY
REFER TO ASSEMBLY DRAWING 510-0528 FOR COMPLETE
PARTS BREAKDOWN AND ORIFICE INFORMATION

BILL OF MATERIALS			
ITEM	PART N°	DESCRIPTION	QTY
1	100-1873	ALX2 - FRONT HOOD PIVOT SLEEVE	2
2	200-0087	1/4" LOCK WASHER	4
3	200-0091	HH- HD - 1/4-20 x 1 x .75 THREAD	4
4	200-0165	SCREW 1/4-20 X 1 1/4" - TRUSS HEAD - PHILIPS - 410 SS	2
5	210-0418	ALFRESCO - 3-1/8"Ø - ALX2 THERMOMETER	1
6	290-0055	HANDLE BAR - 36" KNURLED	1
7	290-0063	HANDLE - END CAP ASSEMBLY	2
8	510-0516	ALX2-42 - FRONT HOOD - WELDED PARTS	1

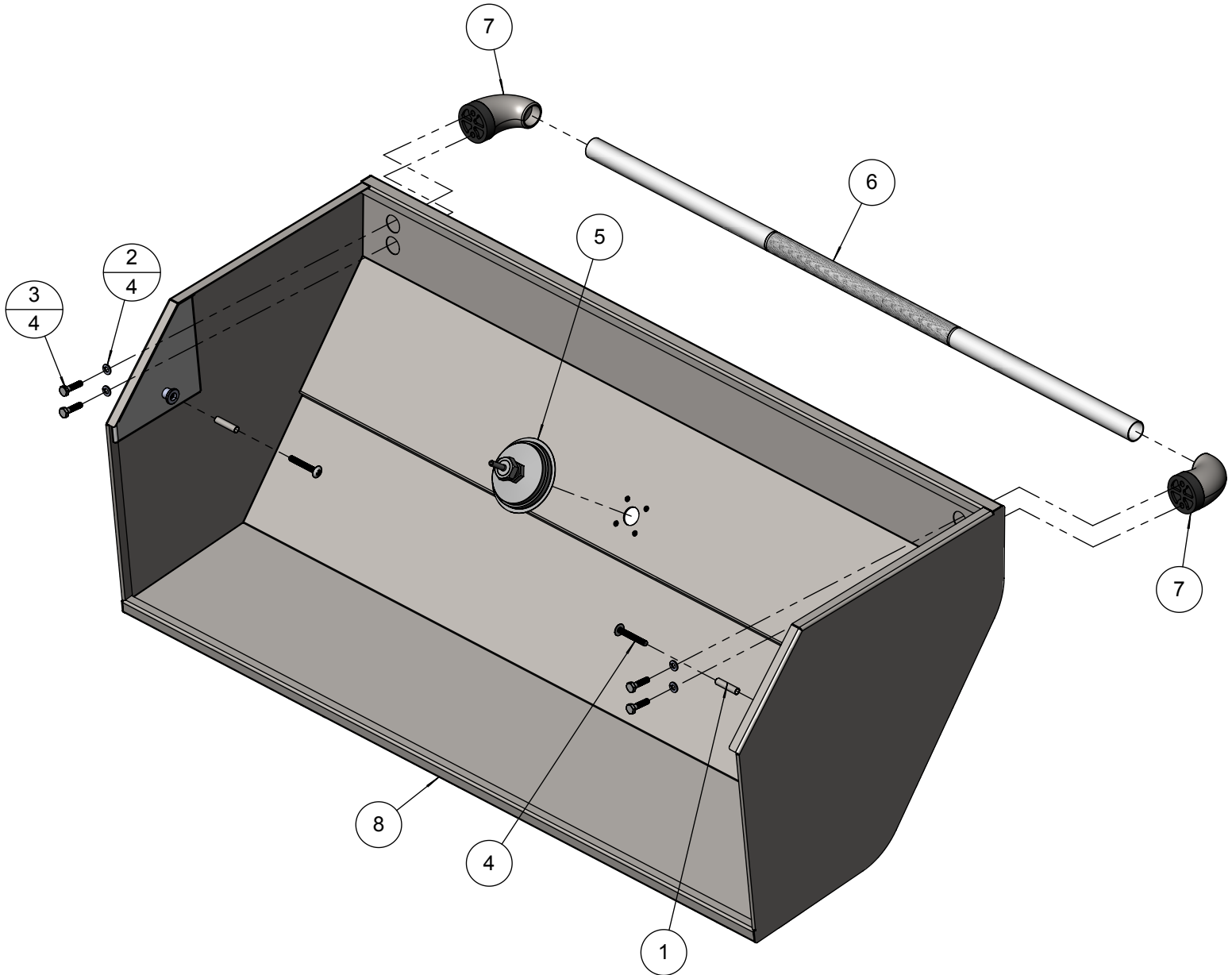

BILL OF MATERIAL

NO.	PART #	DESCRIPTION	QTY
1	100-1880	ALX2 - SMOKER TRAY	1
2	100-1881	ALX2 - SMOKER TRAY HANDLE PLATE	1
3	200-0083	8-32 X 1/4 - PAN HEAD - PHILIPS SCREW	2
4	200-0200	WASHER - # 8 - LOCK SPRING - SS	2
5	290-0135	HANDLE - 3/8"Ø X 3" L - TAPPED	1

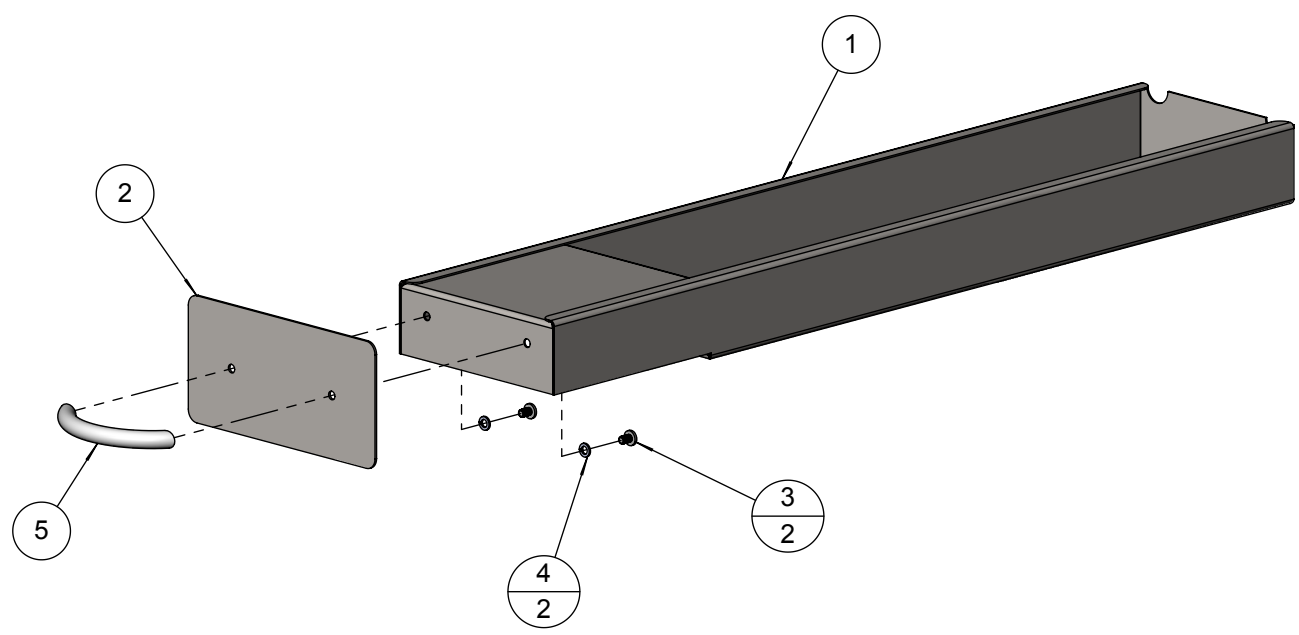

BILL OF MATERIAL

NO.	PART #	DESCRIPTION	QTY
1	100-1895	ALX2 - BRIQUETTE LOCK BAR	3
2	100-1894	ALX2 - BRIQUETTE TRAY BASE	1
3	265-0005	BRIQUETTE - ALFRESCO CUSTOM	24
4	200-0312	SCREW 8-32 x 3/4"- PAN HEAD - PHILIPS - THREAD CUTTER TYPE F	9

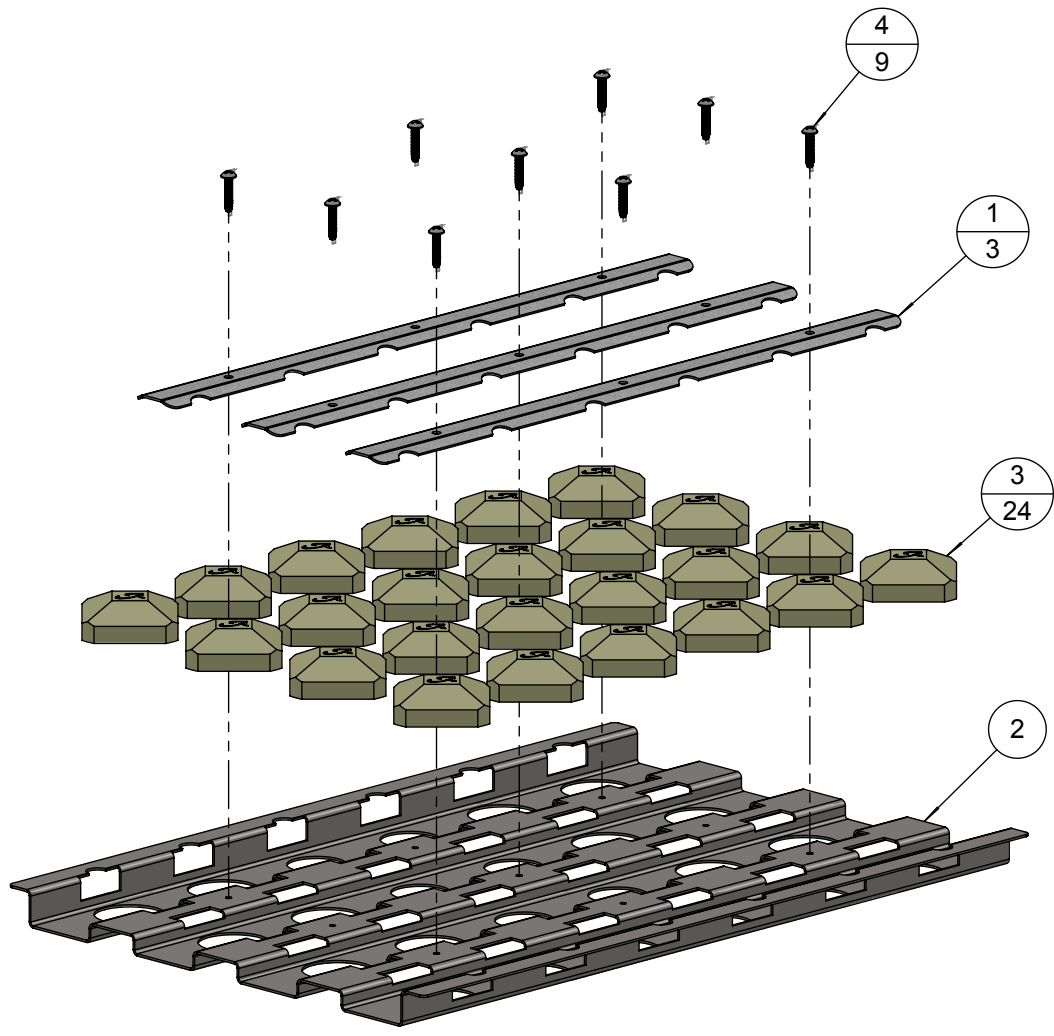

BILL OF MATERIALS

ITEM	PART N°	DESCRIPTION	QTY
1	100-0917	SEAR ZONE™ GAS LINE (8"L x 3/8" Ø - SS. FLEX TUBE)	1
2	100-0917	ROTISSERIE GAS LINE EXTENSION - 3/8"Ø X 8" - SS	1
3	100-1067	ALX2- SMOKER & SZ™ ORIFICE BRACKET	1
4	100-1851	ALX2 - SMOKER ORIFICE BRACKET	1
5	100-1948	ALX2-42 SMOKER GAS LINE	1
6	100-1949	ROTISSERIE GAS LINE (36"L x 3/8" Ø - SS. FLEX TUBE)	1
7	200-0274	ELBOW 90° - CAST IRON - 1/2" FPT x 1/2" MPT	1
8	220-0151	COUPLING 3/8" x 3/8" - COMPRESSION - BRASS	1
9	220-0273	ELBOW 90° - 1/8" FPT x 3/16" COMP	2
10	220-0275	NIPPLE - 1/2" MPT X 3/8" OD FL	1
11	220-0276	ELBOW 3/8" MPT x 1/8" FPT x 3/8" COMP	1
12	220-0277	NIPPLE 1/8"MPT x 1/16"MPT	1
13	220-0280	REGULATOR GAS - MAXITROL RV48CL440002	1
14	220-0341	MANIFOLD - 42" BBQ - 2006 MODEL	1
15	220-0399	ELBOW 1/8-27 FPT x 3/8" Ø COMPRESSION	1
16	290-0030	KNOB BBQ - ALFRESCO "A" LETTER	5
17	290-0041	GAS VALVE - STRAIGHT - WITHOUT ORIFICES	2
18	290-0066	GAS VALVE - ANGLED - ORIFICE: INT= 0.95 mm / EXT=NONE	1
19	SEE NOTE	GAS VALVE - ANGLED WITH ORIFICE >>> SEE NOTE	3
20	SEE NOTE	ORIFICE - IR ROTISSERIE UNIT (SEE NOTE FOR SIZING)	1
21	SEE NOTE	ORIFICE - SMOKER UNIT >>> SEE NOTE	1
22	SEE NOTE	ORIFICE - SEAR ZONE™ >>> SEE NOTE	1

NOTE: ORIFICE OR VALVE ASSEMBLY TO CHANGE ACCORDING TO FUEL SUPPLY: NATURAL GAS OR LIQUID PROPANE

ITEM	NG GAS	LP GAS
	PART #	PART #
19	290-0310	290-0311
20	220-0285	220-0286
21	220-0313	220-0314
22	220-0289	220-0290

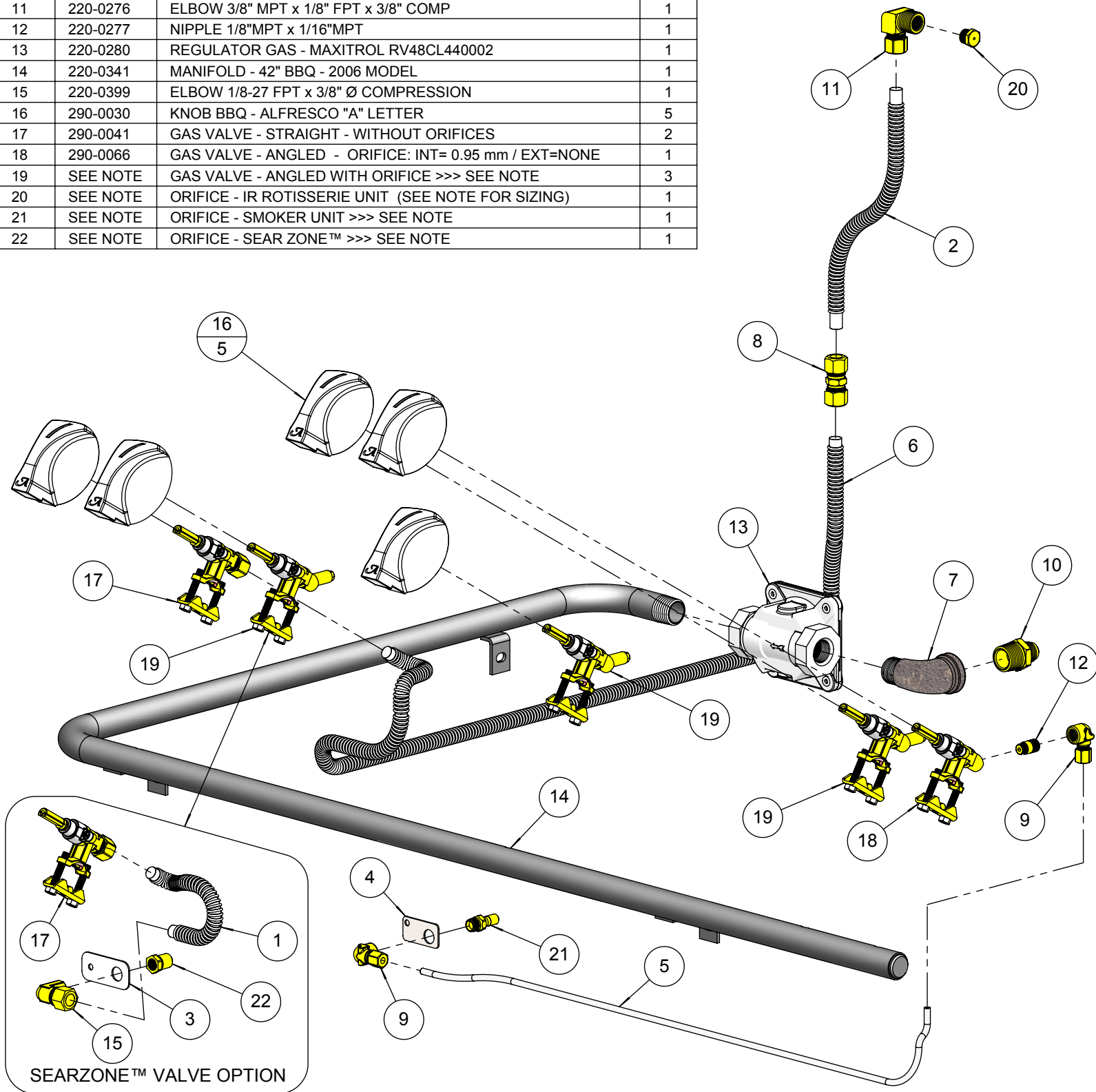

TM

Alfresco

Open Air Culinary Systems

ALX2 • PARTS MANUAL
ALFRESCO™ GOURMET GRILLS
ALL RIGHTS RESERVED • 01/2012