

# Alfresco™

Open Air Culinary Systems



## **ALX2-30 / 30SZ Parts Manual**

*For models S/N: 11-00000 forward.*

**BILL OF MATERIAL**

NO.	PART #	DESCRIPTION	QTY
1	100-1877	ALX2 - ROTISSERIE CHAIN COVER	1
2	200-0086	1/4-20 X 3/8 - TRUSS HEAD - PHILIPS SCREW	6
3	200-0087	WASHER - 1/4" SPRING LOCK- REGULAR - SS	5
4	200-0089	BOLT - HEX HEAD 1/4-20 x 1/2" L	5
5	200-0093	WASHER - PUSH LOCK 1/8" ID X 3/8" OD (LOGO)	2
6	200-0111	SCREW 8-18 X 1/2 - SELF TAP - 410 SS	2
7	290-0031	LOGO - ALFRESCO	1
8	290-0038	BURNER - GRILL - "U" SHAPE	2
9	290-0052	ALFRESCO SEAR ZONE™ BURNER ASSEMBLY	1
10	290-0059	ROTISSERIE DRIP PAN	1
11	290-0096	FORK ASSEMBLY	2
12	290-0116	CHAIN - ANSI # 25 - 1/4" PITCH - .13" Ø X 1/8" ROLLER	1
13	290-0123	SPEAR - ROTISSERIE - 30" - 2006 BBQ	1
14	290-0124	GRILL 30" BBQ - 12 3/4" WIDE - SS	1
15	290-0315	ALX2-30 WARMING RACK - SS	1
16	510-0465	ALX2-30 / 30SZ - GAS MANIFOLD ASSEMBLY	1
17	510-0470	ALX2-30 / 30SZ - FIRE BOX ASSEMBLY	1
18	510-0472	ALX2-30 / 30SZ - GREASE TRAY ASSEMBLY	1
19	510-0474	ALX2-30 / 30SZ - FRONT PANEL ASSEMBLY	1
20	510-0476	ALX2-30 / 30SZ - BACK HOOD WITH RIM ASSEMBLY	1
21	510-0479	ALX2-30 / 30SZ - FRONT HOOD ASSEMBLY	1
22	510-0494	ALX2-30 / 30SZ - ELECTRICAL COMPONENTS	1
23	510-0504	ALX2 - SMOKER BURNER ASSEMBLY	1
24	510-0518	ALX2 - SMOKER TRAY ASSEMBLY	1
25	510-0521	ALX2 - SEARZONE™ GRILL ASSEMBLY	1
26	510-0522	ALX2 - BRIQUETTE TRAY ASSEMBLY	2

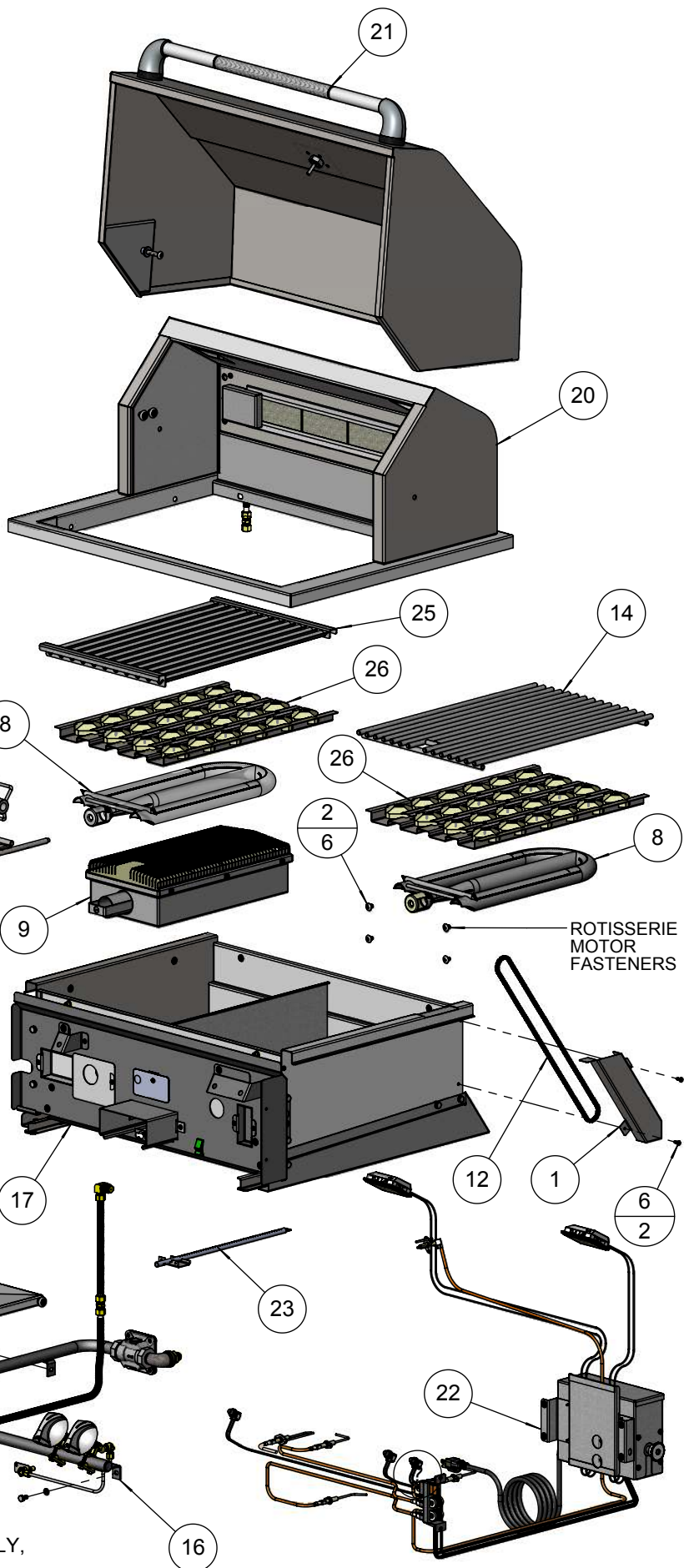

ROTISSERIE MOTOR FASTENERS

**NOTE:**  
 LEFT SEARZONE™ BURNER (9) USED IN ALX2-30SZ MODEL ONLY,  
 OTHERWISE IT IS REPLACED BY U-BURNER (8) IN ALX2-30 UNIT.

**BILL OF MATERIAL**

NO.	PART #	DESCRIPTION	QTY
1	100-0913	30" & 56" BFG BBQ SMOKER GAS LINE	1
2	100-0917	ROTISSERIE GAS LINE EXTENSION - 3/8"Ø X 8" - SS	1
3	100-0917	SEAR ZONE™ GAS LINE (8"L x 3/8" Ø - SS. FLEX TUBE)	1
4	100-1067	ALX2- SMOKER & SZ™ ORIFICE BRACKET	1
5	100-1851	ALX2 - SMOKER ORIFICE BRACKET	1
6	100-1949	ROTISSERIE GAS LINE (36"L x 3/8" Ø - SS. FLEX TUBE)	1
7	200-0274	ELBOW 90° - CAST IRON - 1/2" FPT x 1/2" MPT	1
8	220-0151	COUPLING 3/8" x 3/8" - COMPRESSION - BRASS	1
9	220-0273	ELBOW 90° - 1/8" FPT x 3/16" COMP	2
10	220-0275	NIPPLE - 1/2" MPT X 3/8" OD FL	1
11	220-0276	ELBOW 3/8" MPT x 1/8" FPT x 3/8" COMP	1
12	220-0277	NIPPLE 1/8"MPT x 1/16"MPT	1
13	220-0280	REGULATOR GAS - MAXITROL RV48CL440002	1
14	220-0321	ALX2-30 30SZ GAS MANIFOLD PIPING	1
15	220-0399	ELBOW 1/8-27 FPT x 3/8" Ø COMPRESSION	1
16	290-0030	KNOB BBQ - ALFRESCO "A" LETTER	4
17	290-0041	GAS VALVE - STRAIGHT - WITHOUT ORIFICES	2
18	290-0066	GAS VALVE - ANGLED - ORIFICE: INT= 0.95 mm / EXT=NONE	1
19	SEE NOTE	GAS VALVE - ANGLED WITH ORIFICE >>> SEE NOTE	2
20	SEE NOTE	ORIFICE - IR ROTISSERIE UNIT (SEE NOTE FOR SIZING)	1
21	SEE NOTE	ORIFICE - SMOKER UNIT >>> SEE NOTE	1
22	SEE NOTE	ORIFICE - SEAR ZONE™ >>> SEE NOTE	1

**NOTE: ORIFICE OR VALVE ASSEMBLY TO CHANGE ACCORDING TO FUEL SUPPLY: NATURAL GAS OR LIQUID PROPANE**

ITEM	NG GAS	LP GAS
	PART #	PART #
19	290-0310	290-0311
20	220-0285	220-0286
21	220-0313	220-0314
22	220-0289	220-0290

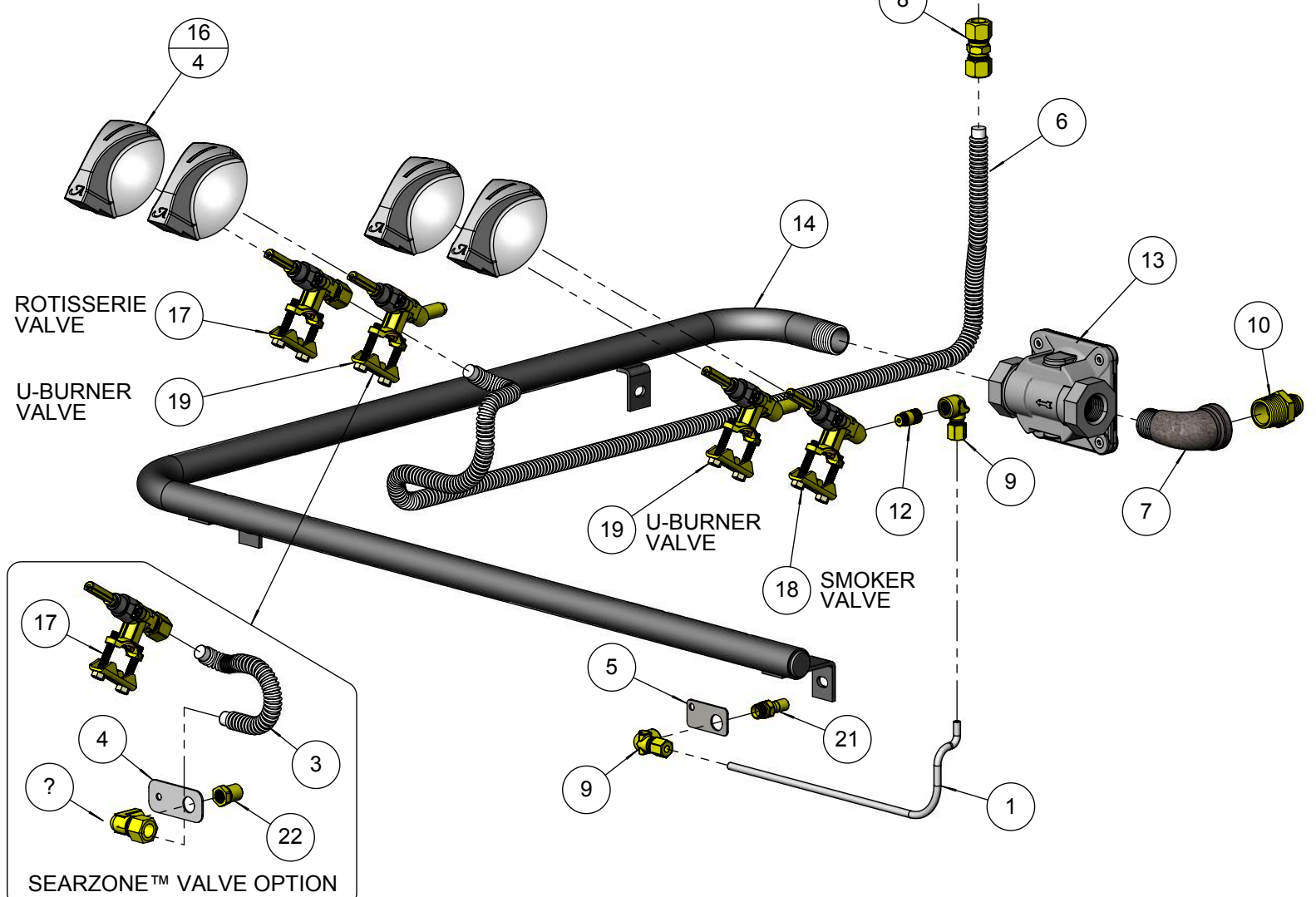

**BILL OF MATERIAL**

NO.	PART #	DESCRIPTION	QTY
1	100-1065	SEARZONE™ OPENING FIREBOX COVER	1
2	100-1831	ALX2 - SMOKER BOX BODY	1
3	100-1833	ALX2 SMOKER BOX TOP DIFUSSER	1
4	100-1846	ALX2 - U-BURNER BRACKET	2
5	100-1847	ALX2 - SEAR-ZONE IGNITER BRACKET / SHIELD	1
6	100-1848	ALX2 - IGNITER SHIELD	2
7	100-1849	ALX2 - IGNITER HOLE COVER	1
8	100-1866	ALX2 - SEAR-ZONE BURNER SHIELD	1
9	100-1884	ALX2 - SEAR-ZONE™ BURNER BRACKET	1
10	100-1887	ALX2 - DUAL VALVE FIREWALL COVE	1
11	100-1888	ALX2 - SINGLE VALVE FIREWALL COVE	1
12	100-1890	ALX2 - FIREWALL OPENING COVER FOR SEARZONE™	1
13	100-1945	ALX2 - DUAL VALVE FIREWALL COVER FOR U-BURNER	1
14	100-1946	ALX2 - FIREWALL OPENING COVER FOR U-BURNER	1
15	200-0087	WASHER - 1/4" SPRING LOCK- REGULAR - SS	17
16	200-0089	BOLT - HEX HEAD 1/4-20 x 1/2" L	17
17	200-0111	SCREW 8-18 X 1/2 - SELF TAP - 410 SS	34
18	200-0305	SPEED NUT TINNEMAN U-TYPE	1
19	510-0471	ALX2-30 / 30SZ FIREBOX - WELDED PARTS	1
20	510-0473	ALX2-30 / 30SZ FIREWALL ASSEMBLY	1
21	510-0502	ALX2 - GREASE TRAY SUPPORT - RIGHT SIDE	1
22	510-0503	ALX2 - GREASE TRAY SUPPORT - LEFT SIDE	1
23	510-0507	ALX2 - FRONT PANEL BRACKET ASSEMBLY - SINGLE SWITCH	1
24	510-0517	ALX2 - FRONT PANEL BRACKET ASSEMBLY - DUAL SWITCH	1
25	510-0520	ALX2 - FIREWALL SUPPORT BRACKET ASSEMBLY	2

**NOTES:**

BRACKETS USED ON ALX2-30 MODEL:

- (1) (4) (6) (7) (13) (14)

BRACKETS USED ON ALX2-30SZ MODEL:

- (4) (5) (8) (9) (10) (12)

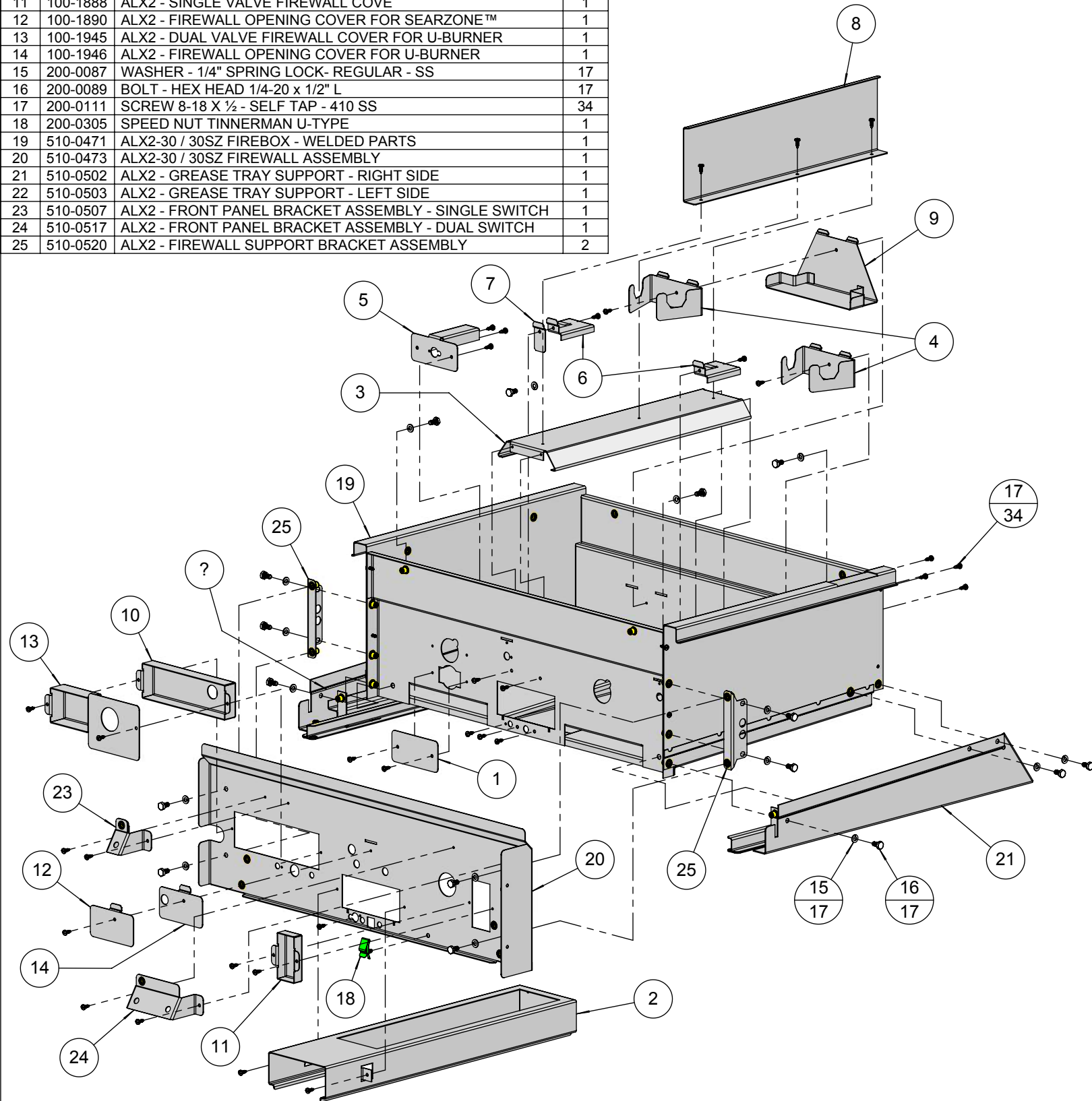

**BILL OF MATERIAL**

NO.	PART #	DESCRIPTION	QTY
1	100-1973	ALX2-30 / 30SZ - GREASE TRAY REMOVABLE PAN	1
2	200-0148	SCREW 10-32 X 3/4" - FLAT HEAD - PHILIPS - 82° - SS	4
3	290-0119	ROLLER WHEEL - STAINLESS STL - 3/4" Ø -	4
4	510-0498	ALX2-30 / 30SZ GREASE TRAY - WELDED PARTS	1

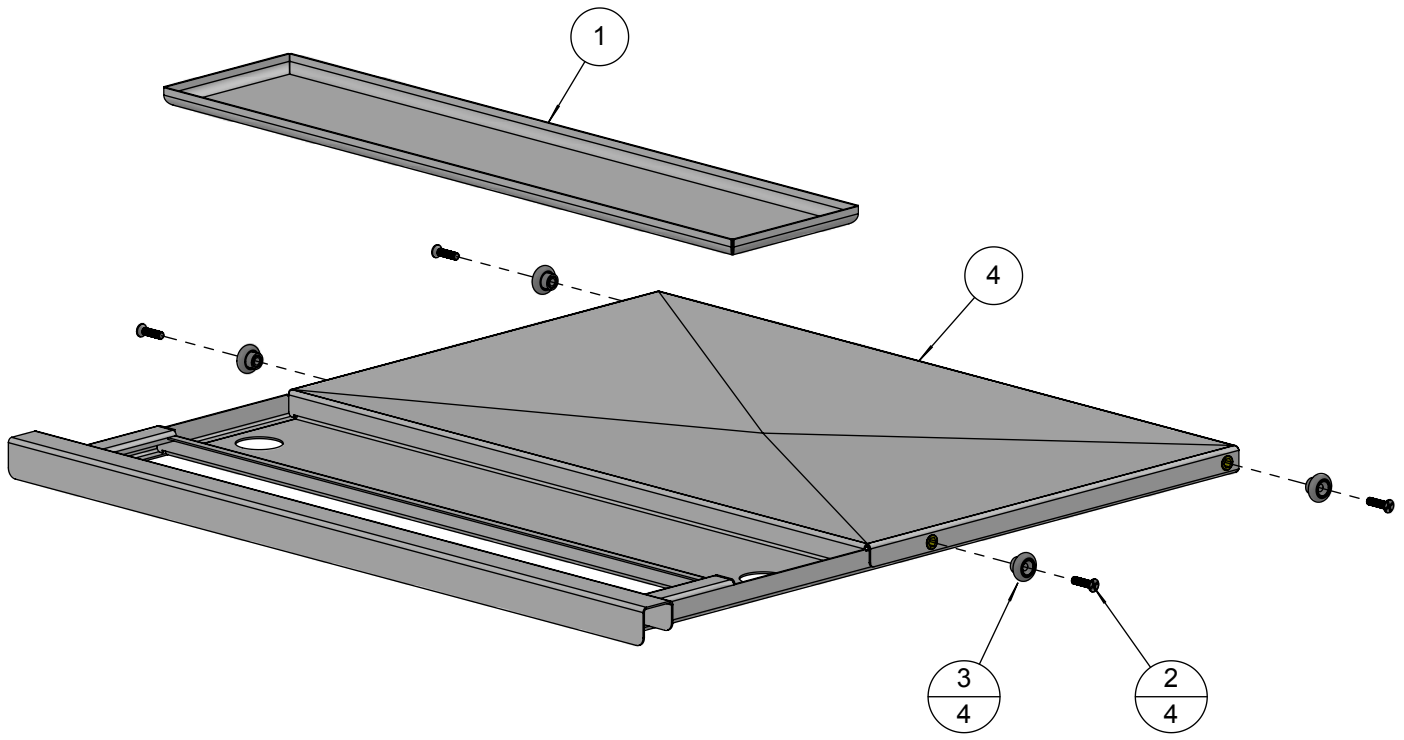

**BILL OF MATERIAL**

NO.	PART #	DESCRIPTION	QTY
1	100-1092	ALX2 - ROTISSERIE GEAR COVER	1
2	200-0062	10-32 X 3/4 - PAN HEAD - PHILIPS SCREW	2
3	200-0086	1/4-20 X 3/8 - TRUSS HEAD - PHILIPS SCREW	2
4	200-0087	WASHER - 1/4" SPRING LOCK- REGULAR - SS	4
5	200-0089	BOLT - HEX HEAD 1/4-20 x 1/2" L	4
6	200-0111	SCREW 8-18 X 1/2 - SELF TAP - 410 SS	1
7	200-0148	SCREW 10-32 X 3/4" - FLAT HEAD - PHILIPS - 82° - SS	2
8	200-0305	SPEED NUT TINNEMAN U-TYPE	4
9	290-0119	ROLLER WHEEL - STAINLESS STL - 3/4" Ø -	2
10	510-0139	ALX2 - ROTISSERIE GEAR ASSEMBLY	1
11	510-0477	ALX2-30 / 30SZ BACK HOOD & RIM - WELDED PARTS	1
12	510-0478	ALX2-30 / 30SZ - ROTISSERIE PANEL ASSY	1
13	510-0483	ALX2-30 / 30SZ- WARMING RACK BRACKET - RT SIDE	1
14	510-0484	ALX2-30 / 30SZ - WARMING RACK BRACKET-LT SIDE	1

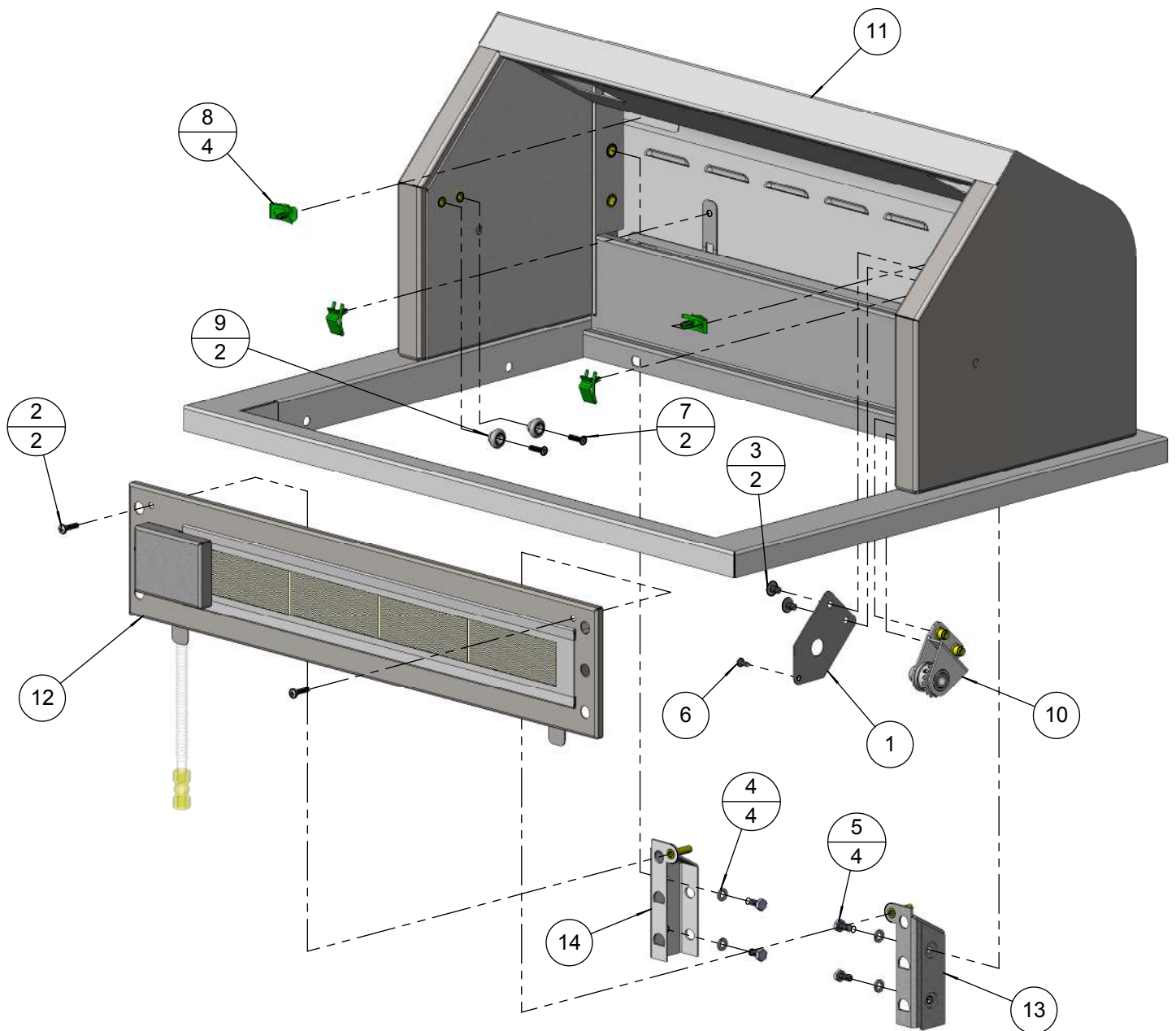

**BILL OF MATERIAL**

NO.	PART #	DESCRIPTION	QTY
1	100-1986	ALX2-30 / 30SZ - ROTISSERIE BURNER IGNITER BRAKET	1
2	100-1987	ALX2-30 / 30SZ - ROTISSERIE BURNER IGNITER COVER	1
3	200-0111	SCREW 8-18 X 1/2 - SELF TAP - 410 SS	5
4	210-0240	ELECTRODE - DUAL TIP "L" SHAPE- ROTISSERIE	1
5	510-0469	ALX2 - ROTISSERIE PIPING SUBASSEMBLY	1
6	510-0482	ALX2-30 / 30SZ - ROTISSERIE PANEL - WELDED PARTS	1

ELECTRODE SHOWN FOR ASSEMBLY PURPOSES ONLY  
REFER TO ASSEMBLY DRAWING 510-0494 FOR ALL  
ELECTRICAL COMPONENTS

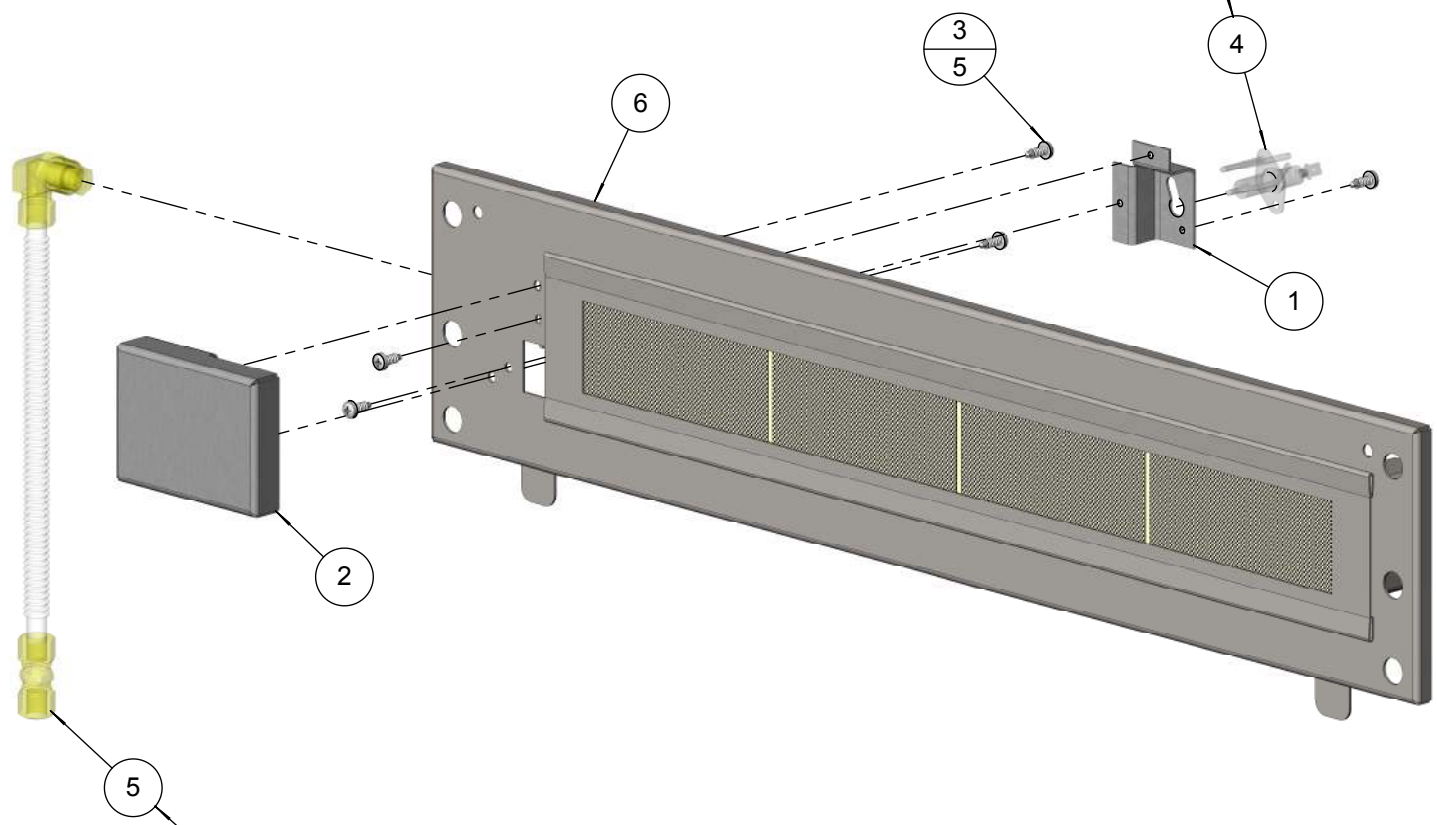

THESE PARTS SHOWN FOR ASSEMBLY PURPOSES ONLY  
REFER TO ASSEMBLY DRAWING 510-0465 FOR COMPLETE  
PARTS BREAKDOWN AND ORIFICE INFORMATION

**BILL OF MATERIAL**

NO.	PART #	DESCRIPTION	QTY
1	100-1873	ALX2 - FRONT HOOD PIVOT SLEEVE	2
2	200-0087	1/4" LOCK WASHER	4
3	200-0091	HH- HD - 1/4-20 x 1 x .75 THREAD	4
4	200-0165	SCREW 1/4-20 X 1 1/4 - TRUSS HEAD - PHILIPS - 410 SS	2
5	210-0418	ALFRESCO - 3-1/8"Ø - ALX2 THERMOMETER	1
6	290-0029	HANDLE BAR - 24" KNURLED	1
7	290-0063	HANDLE - END CAP ASSEMBLY	2
8	510-0480	ALX2-30 / 30SZ - FRONT HOOD - WELDED PARTS	1

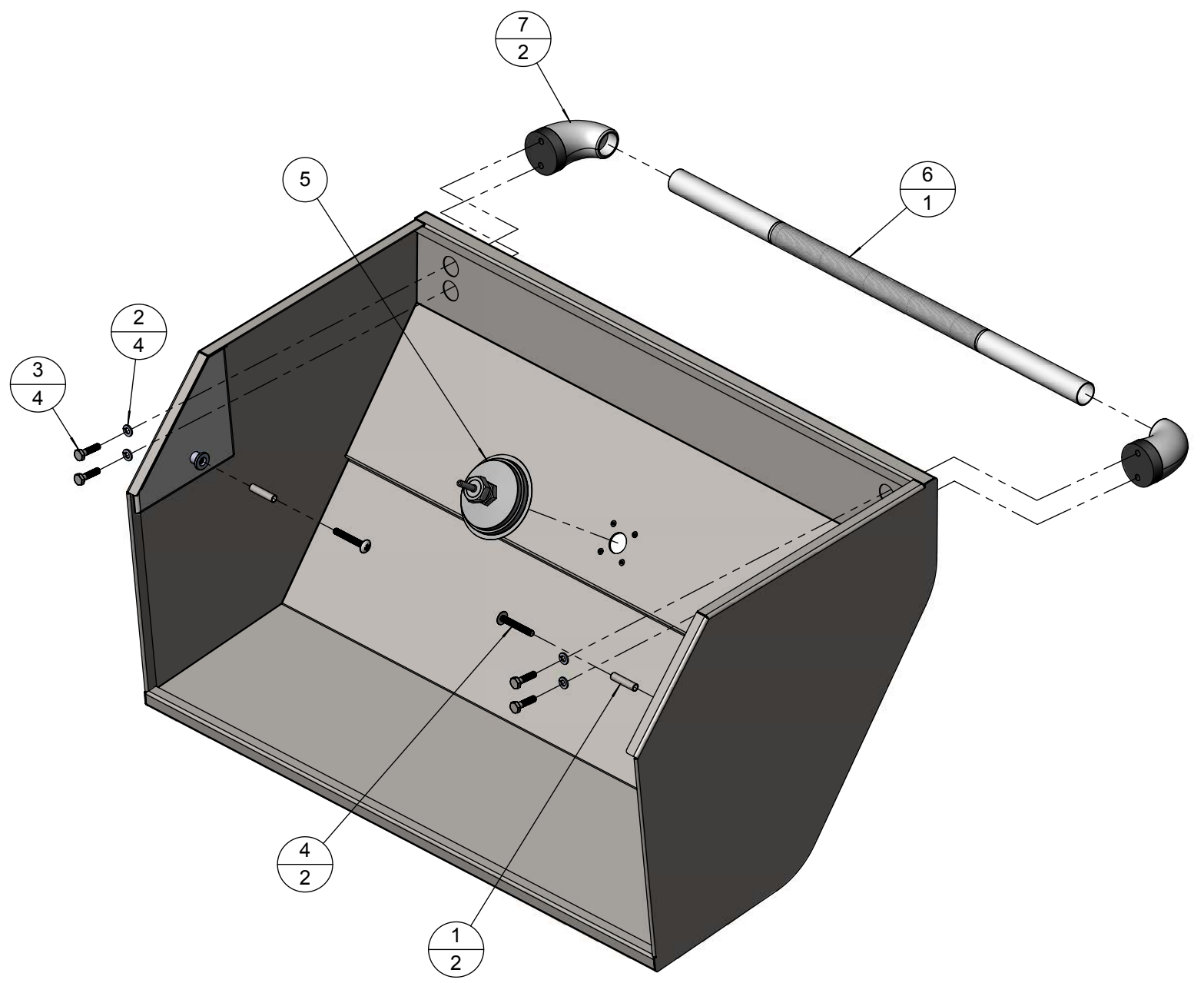



**BILL OF MATERIAL**

NO.	PART #	DESCRIPTION	QTY
1	210-0189	ELECTRODE - "L" SHAPED - U-BURNER / SMOKER	3
2	210-0192	ELECTRODE - DUAL TIP - SEARZONE™	1
3	210-0198	SWITCH - WEATHER BOOT & CAP	3
4	210-0240	ELECTRODE - DUAL TIP "L" SHAPE- ROTISSERIE	1
5	210-0465	IGNITER MODULE (4 POINTS)	1
6	210-0506	LIGHT SWITCH - [OFF/ ON] TOGGLE	1
7	210-0507	ROTISSERIE SWITCH - [OFF/ ON] TOGGLE	1
8	210-0508	IGNITER SWITCH - [OFF/ ON] MOMENTARY	1
9	210-0509	LAMP ASSEMBLY (32" WIRE LENGTH)	1
10	210-0510	LAMP ASSEMBLY (56" WIRE LENGTH)	1
11	210-0520	ALX2-30 / 30SZ - IGNITER WIRE KIT	1
12	510-0514	ALX2 - ROTISSERIE MOTOR BOX ASSEMBLY	1

REPLACEMENT  
ROTISSERIE MOTOR  
PART # 210-0235

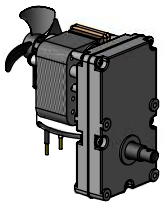

REPLACEMENT LAMP  
G940120 - G9 BASE  
40 W - 120 VAC  
PART # 210-0317

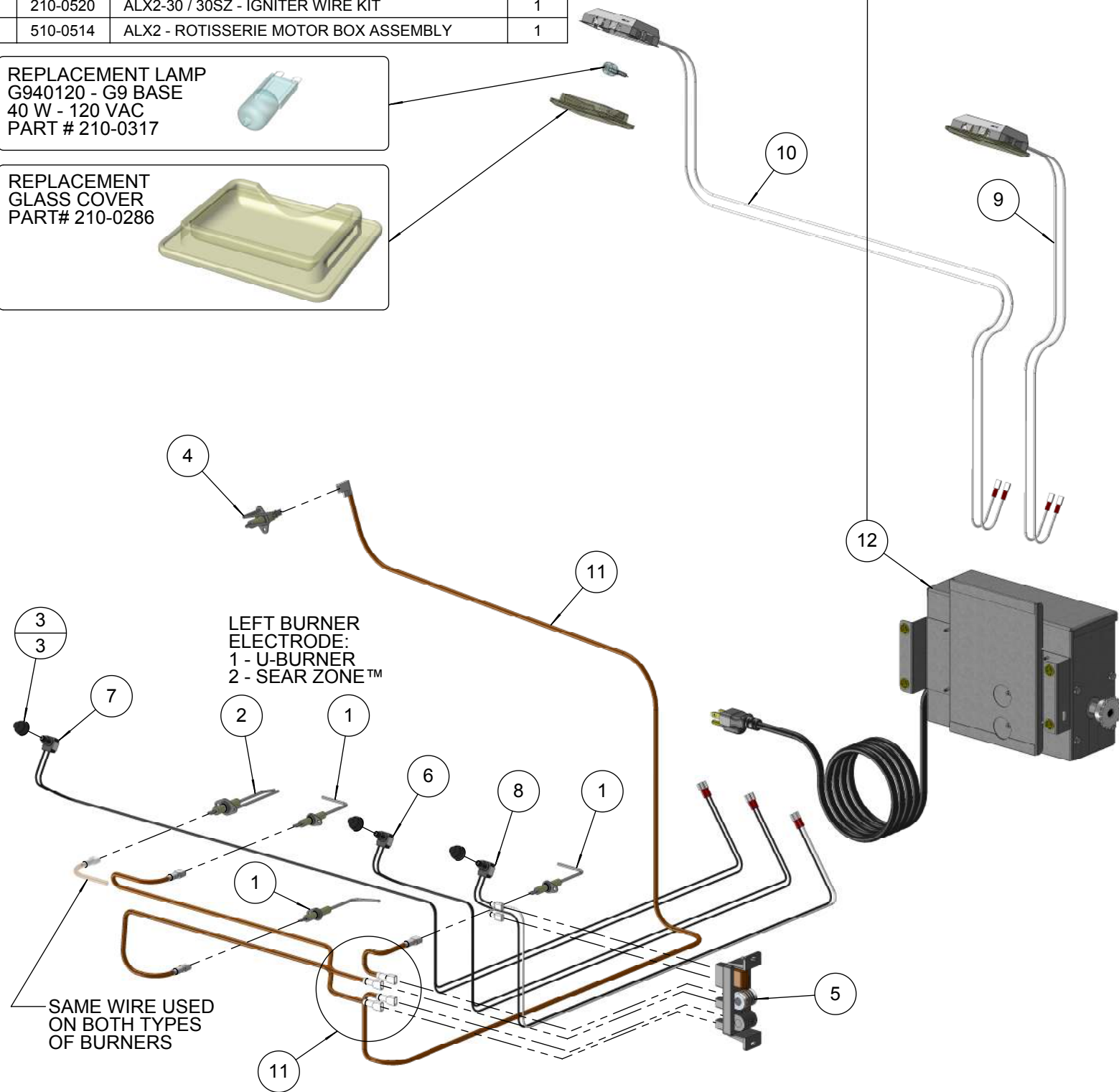

REPLACEMENT  
GLASS COVER  
PART# 210-0286

**BILL OF MATERIAL**

NO.	PART #	DESCRIPTION	QTY
1	100-1880	ALX2 - SMOKER TRAY	1
2	100-1881	ALX2 - SMOKER TRAY HANDLE PLATE	1
3	200-0083	8-32 X 1/4 - PAN HEAD - PHILIPS SCREW	2
4	200-0200	WASHER - # 8 - LOCK SPRING - SS	2
5	290-0135	HANDLE - 3/8"Ø X 3" L - TAPPED	1

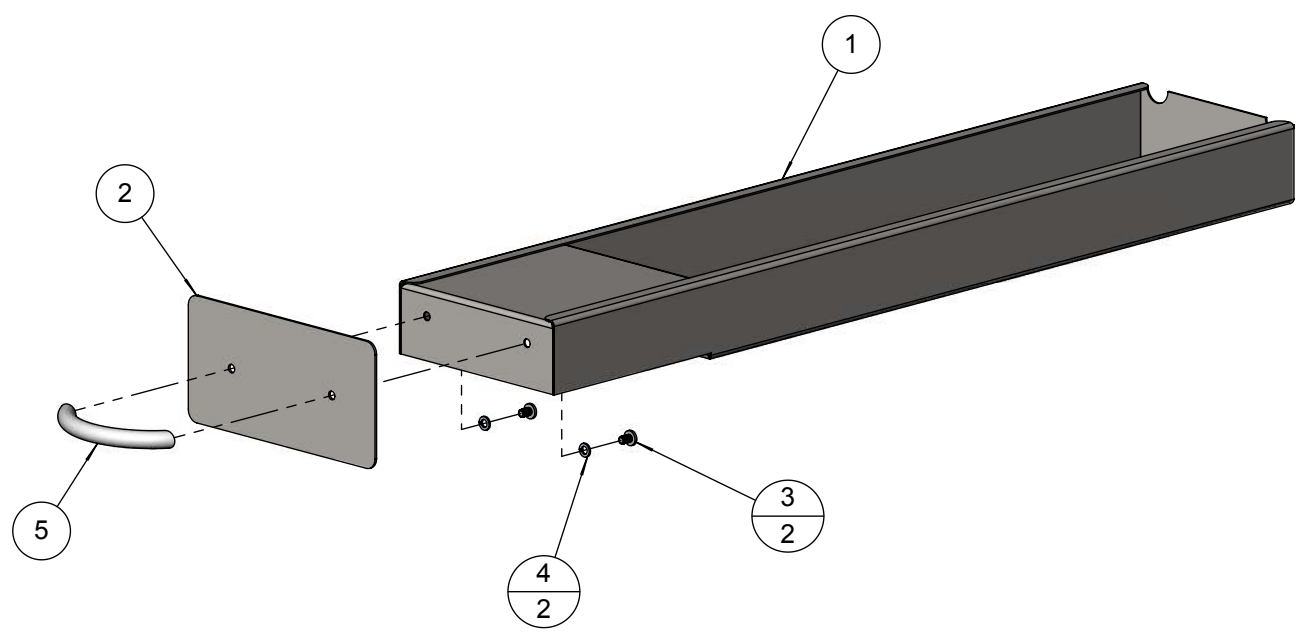

**BILL OF MATERIAL**

NO.	PART #	DESCRIPTION	QTY
1	100-1895	ALX2 - BRIQUETTE LOCK BAR	3
2	100-1894	ALX2 - BRIQUETTE TRAY BASE	1
3	265-0005	BRIQUETTE - ALFRESCO CUSTOM	24
4	200-0312	SCREW 8-32 x 3/4"- PAN HEAD - PHILIPS - THREAD CUTTER TYPE F	9

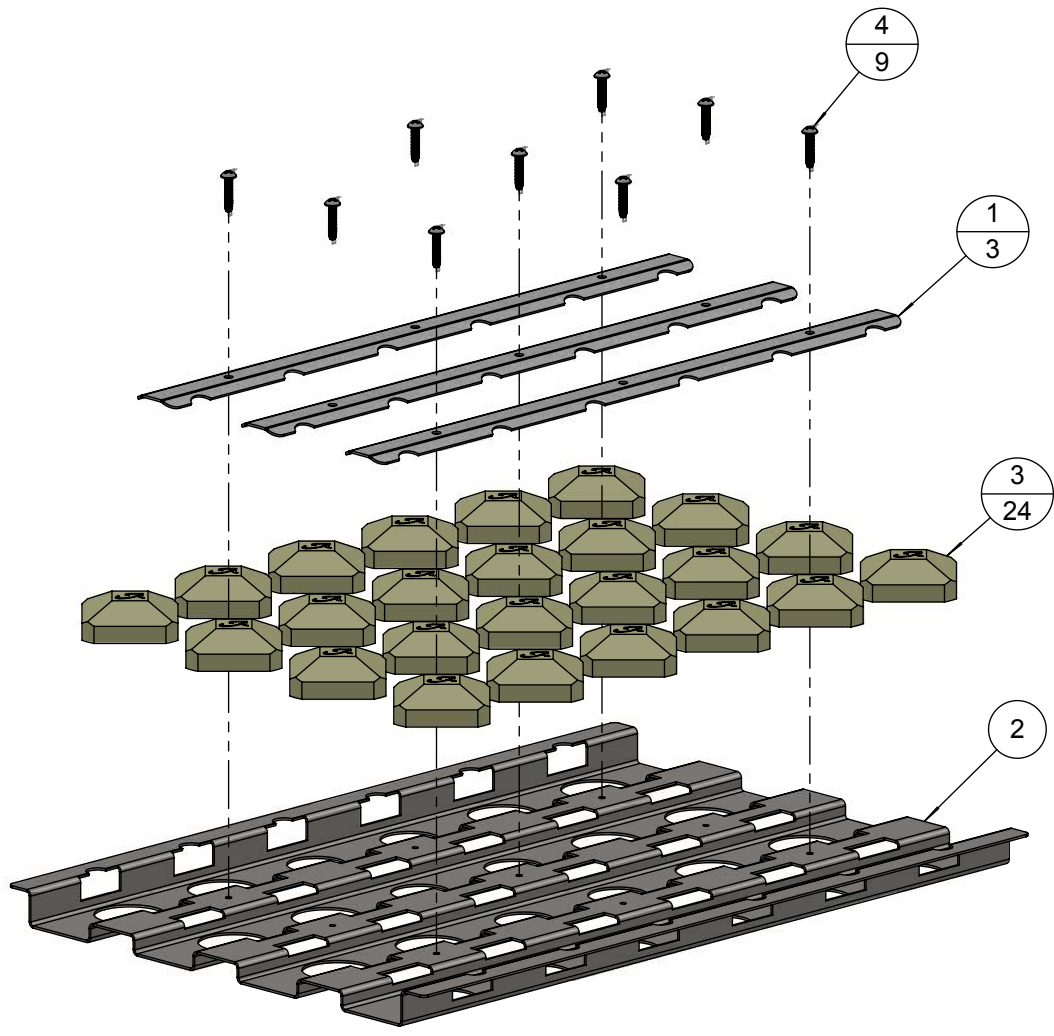

TM

*Alfresco*<sup>TM</sup>

*Open Air Culinary Systems*

ALX2 • PARTS MANUAL  
ALFRESCO<sup>TM</sup> GOURMET GRILLS  
ALL RIGHTS RESERVED • 01/2012