

This Owner's Manual is provided and hosted by [Appliance Factory Parts](http://www.appliancefactoryparts.com).



Americana 4100.0.111 Owner's Manual

**[Shop genuine replacement parts for Americana
4100.0.111](#)**



[Find Your Americana Grill Parts - Select From 27 Models](#)

----- Manual continues below -----



SWINGER

Model 4100



Charcoal Grill User's Manual

For Outdoor Household Use Only. Not for Commercial Use.

Need Help? Need to Register Your Grill? Looking for Parts & Accessories?

Visit us online at www.mecocorp.com Or call Customer Service at 1-800-251-7558

WARNING

- This instruction manual contains important information necessary for the proper assembly and safe use of this appliance. Failure to follow these instructions could result in death or serious injury from explosion or fire.
- Read and follow all warnings and instructions carefully before assembling or using this appliance.
- Keep this manual for future reference. **SAVE THESE INSTRUCTIONS.**

DANGER



CARBON MONOXIDE HAZARD

This appliance can produce carbon monoxide, an odorless toxic gas. Using it in an enclosed space can kill you. Never use this appliance in an enclosed space, such as a camper, tent, car, or home. This appliance is not intended for and should never be used as a heater.

Meco Corporation strives to be a quality supplier of consumer products. If we omitted any parts needed for assembly, or you need troubleshooting information, please contact us using our toll free number or visit our website.

It is important to register your grill and retain your receipt.

1-800-251-7558

8 am - 4:00 pm E.S.T. Monday - Friday

1-423-639-1171 (Telephone)

1-423-639-2570 (Fax)

www.mecocorp.com

Consumer Service Department

MECO CORPORATION

1500 Industrial Road

Greeneville, TN 37745 USA

WARNING

To reduce the risk of serious bodily injury or death:

- Never use a barbecue grill unless all parts of the unit are firmly in place and the grill is stable.
- Never use gasoline, kerosene, alcohol or other volatile fluids as a starter. They can explode.
- Do not use charcoal grill as a space heater.
- Do not use aerosols or store flammable liquids or materials near this charcoal grill. Cap lighter fluid immediately and place a safe distance from the grill.
- Instant light briquettes already have the starter blended in. Do not use lighter fluid, an electric starter, solid, or metal chimney starters.
- Do not add more instant light briquettes once the fire has been lit. To avoid flame-ups, unpleasant fumes and odors, add regular charcoal briquettes if needed.
- Once the barbecue grill has been lit, do not touch the charcoal briquettes to see if they are hot.
- Never add lighter fluid to already hot or warm coals.
- Do not close Hood on flaming charcoal. If closed and re-opened, the flames could leap out and burn.
- Do not wear loose clothing (example: hanging shirt tails, clothing with frills, etc.) around a charcoal grill while in use or hot.
- Do not lean your body over the charcoal grill when lighting it, while it is hot or is in use.
- Do not touch hot surfaces. Use heat resistant gloves, long-handled tongs, or barbecue mitts at all times since the grill will become very hot.
- Do not move a charcoal grill when in use or hot.
- Do not allow children to operate or play near a charcoal grill. Keep animals and bystanders out of the grill area. Do not leave grill unattended.
- Allow grill to cool before handling parts or cleaning.
- To avoid a fire, allow coals to burn out completely and let the ashes cool for 48 hours before disposing.
- Do not attempt to extinguish a grease fire with water or other liquids. Always have an ABC fire extinguisher, baking soda, a bucket of sand or a garden hose ready in case of an uncontrolled fire.



WARNING: Cancer and Reproductive Harm -

www.P65Warnings.ca.gov





















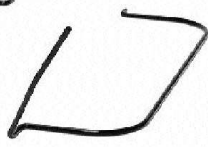

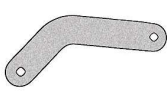

Preparation for Assembly - Parts Illustration

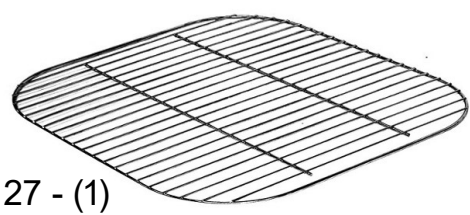
TOOLS NEEDED: Phillips head Screwdriver and a 3/8" open end wrench or a pair of pliers.

LAY OUT AND IDENTIFY ALL PARTS. DO NOT DISCARD CARTON OR PACKING UNTIL YOUR GRILL IS COMPLETELY ASSEMBLED. READ ALL ASSEMBLY AND SAFETY INSTRUCTIONS IN THE OWNER'S MANUAL BEFORE YOU START.

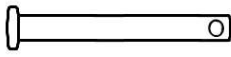
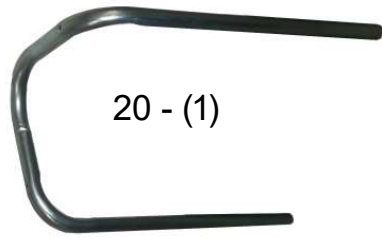
For easier set-up, follow instructions of each step in the order they are written as you look at the diagrams.

Item - (Quantity)

1 - (6)		12 - (1)		22 - (1)	
2 - (17)		13 - (1)		23 - (1)	
3 - (2)		14 - (1)		24 - (1)	
4 - (2)		15 - (2)		25 - (1)	
5 - (13)		16 - (2)		26 - (1)	
6 - (10)		17 - (1)		27 - (1)	
7 - (2)		18 - (1)			
8 - (2)		19 - (2)			
9 - (2)		20 - (1)		21 - (1)	
10 - (2)					
11 - (2)					

C

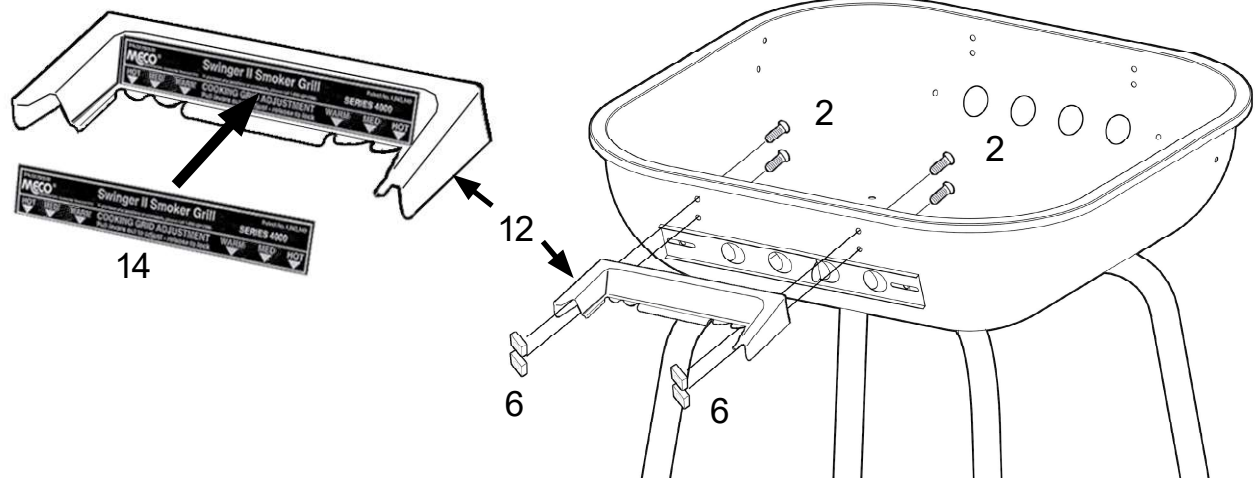

- 6 - (4) [Square nuts]
- 2 - (4) [Screws]

D

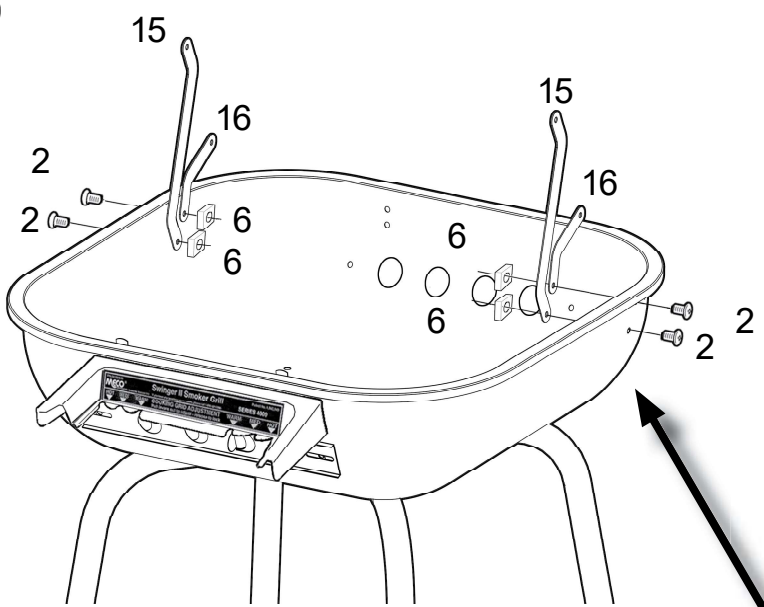

- 6 - (4) [Square nuts]
- 2 - (4) [Screws]

E

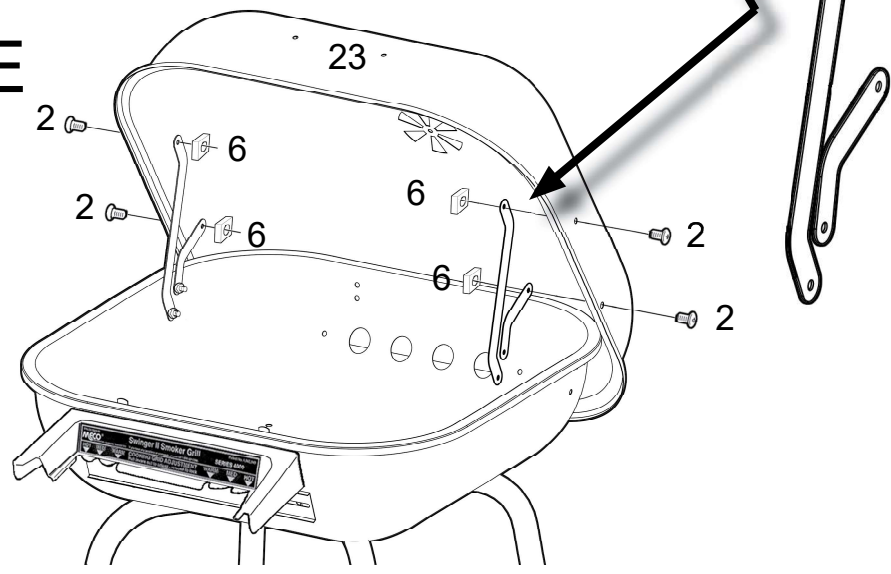

- 6 - (4) [Square nuts]
- 2 - (4) [Screws]

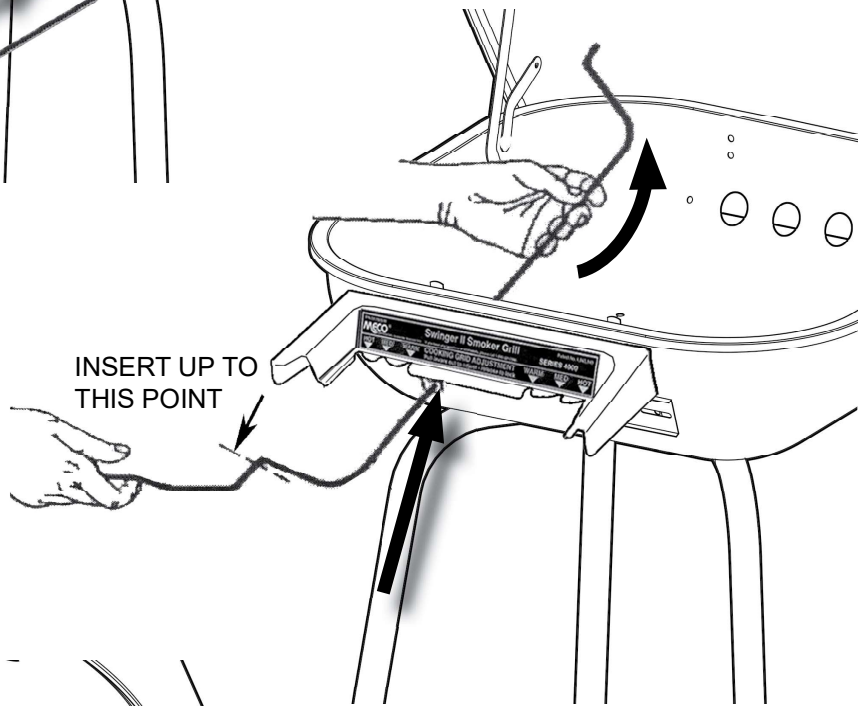
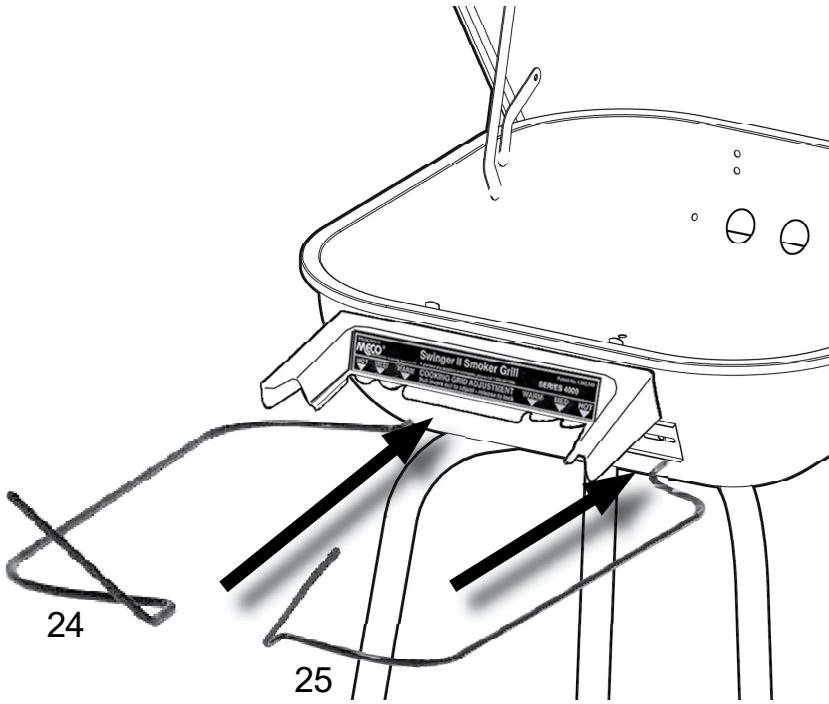

F

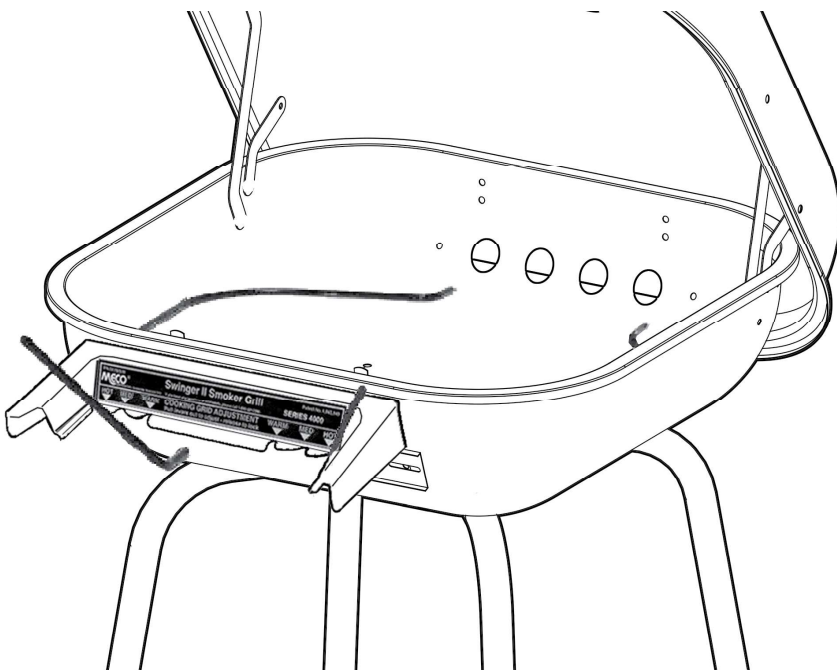

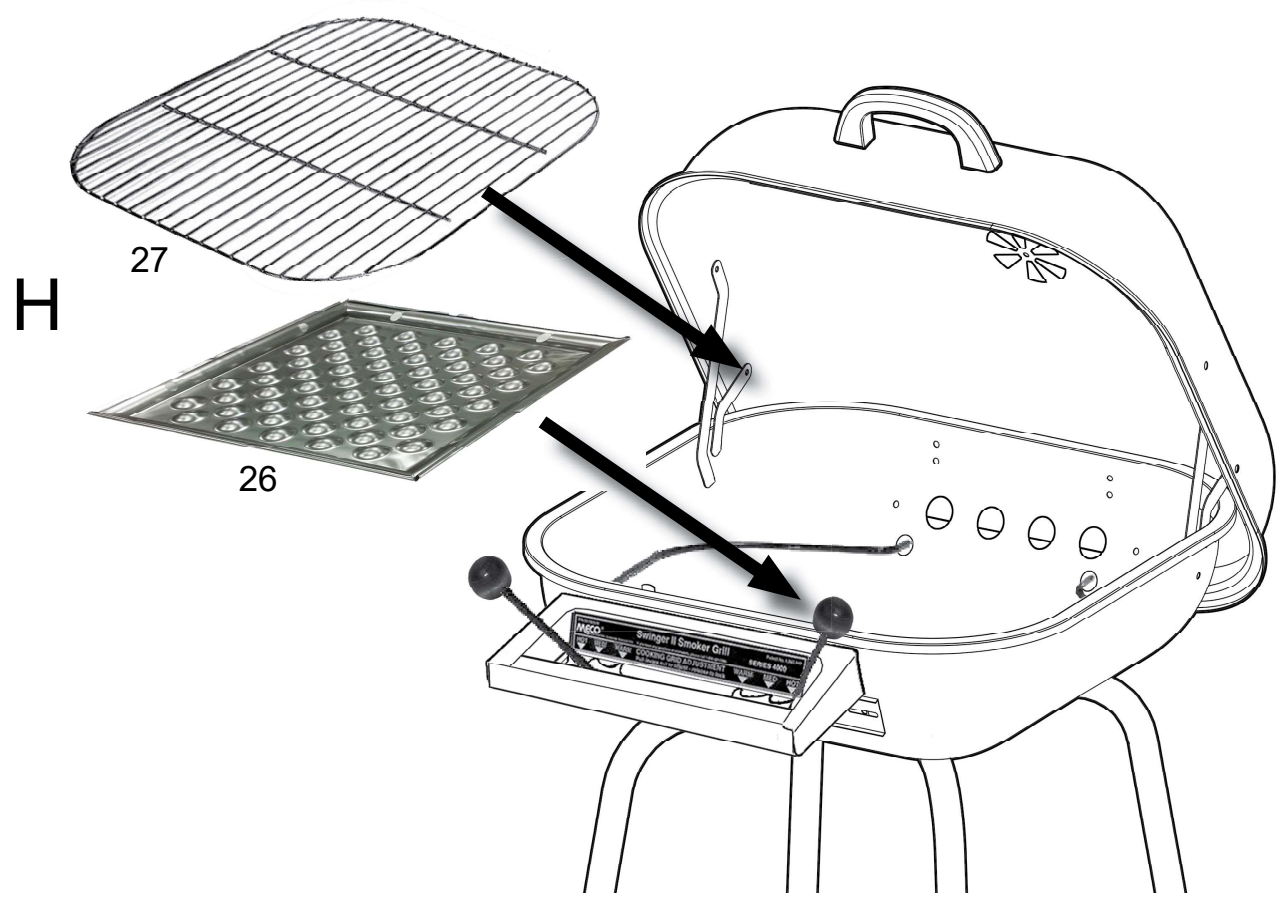
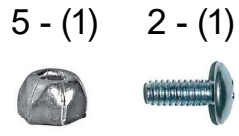
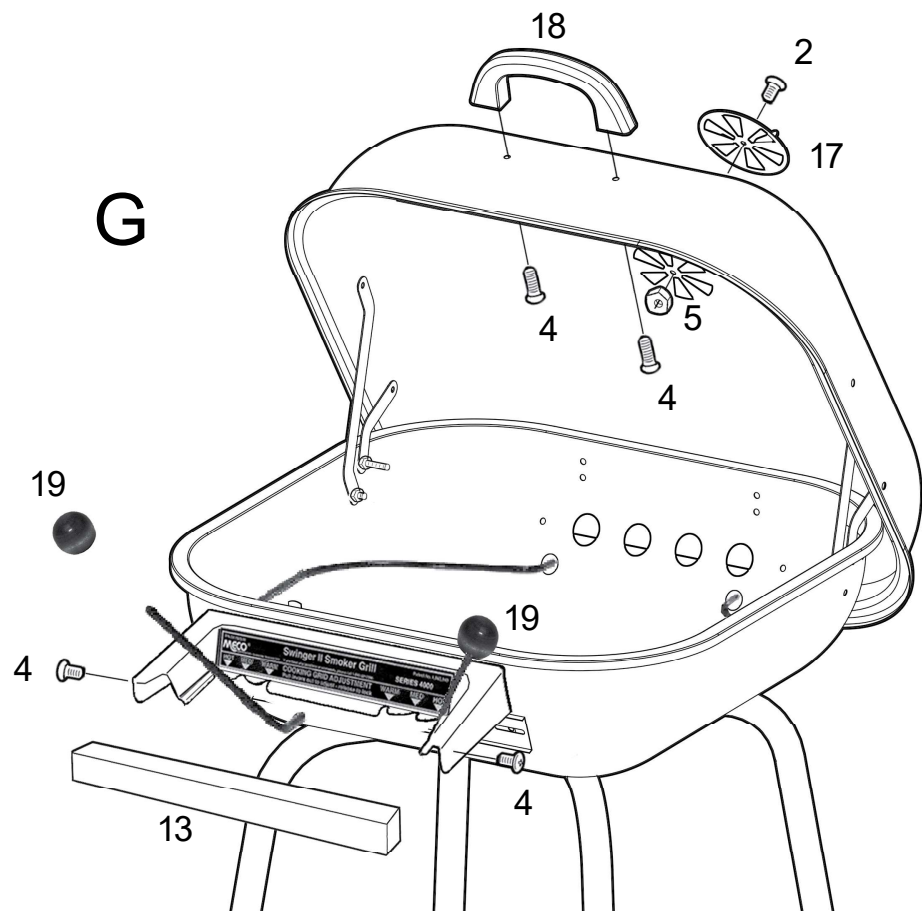

USING CHARCOAL

To reduce the risk of serious injury or death from explosion or fire:

- Be careful when burning charcoal to avoid getting burned from flame, heat or hot coals.
- Be aware of the wind blown sparks.
- The use of alcohol, prescription or non-prescription drugs could impair the consumer's ability to properly assemble or safely operate this appliance.

SELECTING A LOCATION

To reduce the risk of serious injury or death from explosion or fire:

- Locate your grill an open area away from buildings, dry leaves, or brush, and at least 10 feet away from your house or building.
- Always make sure the grill is on a level, stable surface and not tilted toward the front or back.
- Do not use the grill in a garage, breezeway, carport, porch, high traffic area, on or under any surface that can catch fire.
- Do not use a charcoal grill indoors, on recreational vehicles, or on boats.

STARTING A FIRE

To reduce the risk of serious injury or death from explosion or fire:

- Make certain you leave the Hood all the way open until the flames have died down.
- Should electrically operated starters be used, be sure they are properly grounded according to local codes. Electrical cords should be placed away from walkways or traffic areas.
- Do not use lighter fluid, an electric fire starter solid, or chimney starters with instant light charcoal. This could cause flame-ups, unpleasant fumes and odors.
- Use barbecue mitts and long handled tongs to spread out the hot charcoal.
- If there is any type of fire that threatens either personal safety or property, call the fire department.

COOKING ON YOUR GRILL

- To reduce risk of burns from the hot air and steam trapped inside, open the Hood carefully when grill roasting.
- Do not grasp the Cooking Grid with your hands while it is hot. Use barbecue mitts for handling.
- If flare-ups occur, close the Vents for at least one minute to stop flare-up. Do not use water.

END OF COOKING SESSION

To reduce the risk of serious injury or death:

- Allow the grill to cool completely before cleaning, transporting or storing.
- Empty and clean the Fire Bowl after each cooking session so excessive grease and ashes do not accumulate. See Cleaning instructions on next page.
- Store your charcoal grill in a cool dry place.
- Do not store charcoal and lighter fluid indoors.
- Store out of the reach of children.
- Do not store additional charcoal and lighter fluid under or near the grill while it is hot.
- To avoid a fire or explosion, do not store charcoal or lighter fluid near a heat source.
- Always cap the lighter fluid when not in use.

To reduce the risk of injury or parts falling out during transport:

- Make sure legs are folded and locked and hood and bowl are latched securely.

Starting a Fire:

Make a pyramid shaped stack of briquettes near the front of the Bowl



For Grilling:

Spread briquettes evenly



For Indirect Cooking:

Place a foil pan under the meat and surround it with briquettes



STARTING A CHARCOAL FIRE IN YOUR SWINGER GRILL

STEP 1. Use a high quality hardwood charcoal to make sure you get a good fire. Charcoal briquettes made from maple, oak, birch or elm woods will burn clean with very little smoke and without unpleasant odors.

STEP 2. Open the hood and all the vents.

STEP 3. Remove the Cooking Grid. Line the bottom of the Bowl with heavy duty aluminum foil.

STEP 4. Place about three pounds of charcoal (35-40 briquettes) in the bottom of the grill.

STEP 5. Make a pyramid shaped stack near the front of the Bowl and pour on charcoal lighter fluid following the instructions on the container.

Warning: Do not use lighter fluid if you are using instant light briquettes or an electric fire starter.

STEP 6. Let the lighter fluid soak in for approximately one minute.

STEP 7. Carefully light the charcoal and let it burn for 20 to 30 minutes or until it is covered with a light gray ash. NOTE: For a hot fire in a hurry, use a fan or a bellows to create extra air movement over the charcoal. Be careful not to blow the ashes out of the grill.

STEP 8. Use long-handled tongs to arrange the charcoal in a checkerboard pattern. Leave about one-half inch of space between each piece of charcoal. This will help you to avoid flare-up from the meat drippings and will give you more even heat for grilling.

COOKING ON YOUR SWINGER GRILL

1. Cooking on the Grids: You can adjust the cooking temperature of your grill in three ways. For SLOWER cooking, move both knobs towards the center of the grill to raise the cooking grid. For FASTER cooking, lower the cooking grid by pulling on both knobs and moving them to the outside. You can adjust both sides at the same time, or one at a time. By raising one side and lowering the other, you can cook rare meat and well done at the same time.

Use the lowest position for searing steaks and hamburgers or when more heat is needed. Foods cook very fast at this position, so watch your food carefully.

Raise the grid to the middle slot to finish cooking steaks and hamburgers. Start cooking with the grid in the middle position for meats, such as pork and chicken, that have to be cooked a long time. The top grid height is good for baking or warming breads, or any time your fire is very hot.

2. TILT-AWAY HOOD...Leave the hood open for "Texas Style" open air barbecuing. Close the hood for "Smoker" cooking or when you want to hold in all the heat.

3. ADJUSTABLE DRAFT...Leave the hood vent open for the most heat, close it to lower the heat. It takes a few minutes for the charcoal to react to the vent adjustment.

4. SMOKING...For true smoke flavor, use chips or chunks of wood from nut or fruit trees such as hickory, walnut, cherry or apple. Soak the chips in water overnight (or at least 2 hours before cooking) so they will not burn quickly when you put them on the charcoal or directly on the electric element. Do not use more than a small handful of chips or 3-4 chunks at a time. The wood will ignite when dried and rapidly increase the heat in the grill so pay close attention and extinguish the chunks if they continue to burn.

After you get the fire started and charcoal spread out, scatter the soaked chips on top of the hot charcoal using tongs. Spray the Cooking Grid with cooking spray so food does not stick, then snap the Cooking Grid in place. CAUTION: Use long barbecue mitts to snap in the grid. Place the meat on the grid, close the hood, and adjust the vent for the desired heat.

5. FLARE-UPS...Close the vent for at least one minute to stop flare-ups. You do not have to use water.

6. PUTTING OUT THE CHARCOAL...Save your charcoal to use again by closing the hood and all vents. The charcoal will go out in a little while and the next time you cook, you will need to add less new charcoal.

CARE OF YOUR SWINGER GRILL

For easier cleaning and before each time you cook... line the bottom of the fire bowl with heavy duty or a double layer of aluminum foil. Make sure you leave all the vents uncovered.

Ashes...Remove the ashes as soon as possible after each time you cook but wait until the charcoal has cooled. Pour out the ashes or wrap them in the aluminum foil from the bottom of the Bowl. Never put hot ashes in a garbage container. You can save any leftover charcoal for use next time you cook. Use a garden hose to wash out accumulated grease and ashes. Let the grill dry before closing.

Cooking grid...Use a detergent and hot water solution just as you would for any cooking equipment. A stiff brush may be helpful in removing heavy grease deposits.

Hood and Bowl...Dampen a cloth in hot water and a detergent solution. Then, wipe both the inside and outside of the hood and bowl. CAUTION: Be careful around sharp edges of the grill. Wipe all areas dry before storing. Note: Do not use oven cleaner or abrasive cleaner on your grill. This may cause damage to the paint finish.

Storage...After you have cleaned your grill, store it in a clean, dry area. Leave all the vents open so moisture does not collect inside causing rust. If you store your grill outside, close the top vent to keep the rain out.

If rust appears on your grill, clean and buff the affected area with steel wool. Touch up bare metal with a high heat paint specified for barbecue grills.

RECIPES YOU CAN USE AGAIN AND AGAIN

Juicy Burgers...

1 beef bouillon cube	1/2 teaspoon salt
1/2 cup boiling water	1/2 teaspoon pepper
1 pound ground beef	1/2 teaspoon ground sage
1/3 cup dry bread crumbs	1/2 teaspoon ginger
1 teaspoon grated lemon peel	4-5 hamburger buns toasted

Dissolve bouillon cube in boiling water. Mix thoroughly with beef, crumbs, lemon peel and seasoning. Shape into four or five patties and chill thoroughly. Grill on High Setting until desired temperature is reached. Serve on toasted buns. Makes 4 or 5 servings.

Barbecued Pork Chops...

1 1/2 cups water	2 teaspoons salt
3/4 cup catsup	1/2 teaspoon pepper
3/4 cup white vinegar	1/4 teaspoon hot sauce
1 medium onion, chopped	8 (1 1/4 inch thick)
1 clove garlic, minced	pork loin chops
3 tablespoons brown sugar	
1 tablespoon Worcestershire sauce	

Combine first 10 ingredients in a medium saucepan, stirring well; bring to a boil. Reduce heat, and simmer, uncovered, 30 minutes, stirring occasionally. Remove sauce from heat; set aside.

Trim excess fat from chops. Grill over medium heat using Direct method until desired temperature has been reached. Baste frequently with sauce. Bring remaining sauce to a boil in a saucepan. Remove from heat. Serve pork chops with remaining sauce. Makes 8 servings.

Lemon & Dill Grilled Salmon

1 large salmon fillet (either with or without skin)
 1/4 cup of lemon juice (approx. 1/2 lemon)
 1/4 - 1/2 cup of mayo
 fresh or dried dill to taste
 coarsely ground black pepper to taste
 1/4 cup of olive oil (only for skin on fillet)

Wash and dry the fillet. If cooking a skin-on fillet, apply olive oil to the skin only to keep the fillet from sticking to the cooking grid. Flipping is not necessary. Apply lemon juice and let sit for 5 minutes. Generously spread mayo on top of the fillet. NOTE: This step is to help keep the meat moist and not for flavor purposes. Season with dill and pepper to taste. Cook until the meat starts to flake and is barely opaque in the center. This takes roughly 10-15 minutes on the High Setting. The salmon will continue to cook after removing from the grill. Do not overcook.

BARBECUED PORK

Thicker pork cuts should be cooked slowly. The secret is to brown the meat, but not to grill it so long that it becomes dry.

Yield: 4 servings
 Grill temp.: MED
 Cooking time: 30-45 minutes
 4 pork steaks or chops, 1/2-inch thick
 1 beef bouillon cube
 2 tablespoons hot water
 1 teaspoon ground ginger
 1/4 cup soy sauce
 2 teaspoons salt
 1/4 cup molasses

Dissolve bouillon cube in hot water, add remaining 4 ingredients and blend. Put meat in dish and pour marinade over meat; cover and refrigerate 2 hours, turning occasionally. Remove pork from marinade, drain well and grill on preheated grill at MEDIUM setting for 15 minutes per side, basting occasionally with remaining marinade.

GARLIC SHRIMP

This recipe could serve as an appetizer or a main dish depending on the size of the shrimp. Thread the shrimp on skewers so they will not fall through the grid, or grill them on a aluminum foil.

Yield: 4 servings
 Grill temp.: HIGH
 Cooking Time: 10 minutes
 12 ounces frozen peeled and deveined shrimp
 1/2 cup butter or margarine
 4 cloves garlic, sliced
 1/4 cup fresh lemon juice
 1 tablespoon dehydrated parsley flakes
 1/2 teaspoon seasoned salt
 1/2 teaspoon lemon and pepper seasoning

Cook garlic in butter for 2 to 3 minutes; add remaining ingredients except shrimp and heat until blended. Put shrimp in shallow dish; pour marinade over shrimp and let stand for 1 hour. Thread shrimp on metal skewers and cook on preheated grill at HIGH for 5 minutes per side. Turn and baste occasionally.



Meco Corporation
Manufacturing Grills Since 1969
Electrics, Smokers, Charcoal & Gas
Your Style, Your Choice!

Meco Corporation
Grills de fabricación desde 1969
Electricidad, Fumadores, carbón y gas
Su estilo, su opción!

Meco Corporation
Grills de fabrication depuis 1969
Électrique, fumeurs, charbon et gaz
Votre style, votre choix!

Check www.mecocorp.com for more Tips, Recipes and Links.

For more recipes, updates and tips follow us on:

Facebook at www.facebook.com/americanagrills

Instagram at www.instagram.com/americana_grills

Pinterest at www.pinterest.com/mecocorporation/americana-grills/

Youtube at www.youtube.com/c/AmericanaGrills

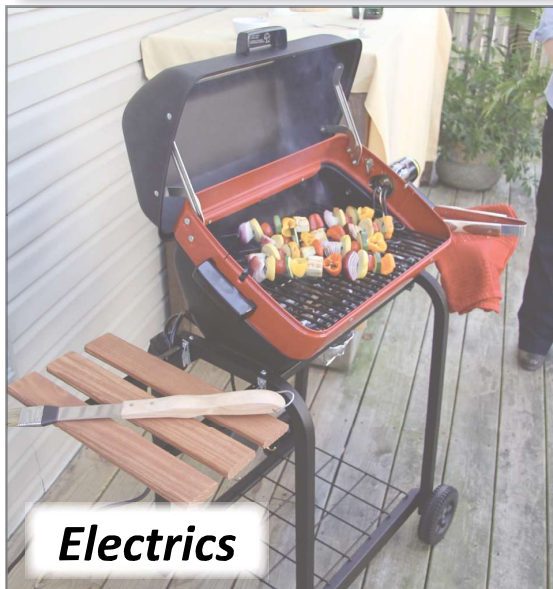

To validate your warranty, register your grill at www.mecocorp.com
Replacement parts require proof of purchase. Please save your receipt.

Para validar la garantía, inscriba su parrilla en www.mecocorp.com
Las piezas de repuesto requieren una prueba de compra. Por favor guarde su recibo.

Pour valider votre garantie, enregistrez votre gril à www.mecocorp.com
Les pièces de rechange exigent la preuve d'achat. S'il vous plaît enregistrer votre réception.