



Model 5025
Charcoal
Water Smoker Grill



Model 5029
Electric
Water Smoker Grill

Water Smoker User's Manual

For Outdoor Household Use Only. Not for Commercial Use.

Need Help? Need to Register Your Grill? Looking for Parts & Accessories?

Visit us online at www.mecocorp.com

Or call Customer Service at 1-800-251-7558

MECO CORPORATION
GREENEVILLE, TN

WARNING

- This instruction manual contains important information necessary for the proper assembly and safe use of this appliance. Failure to follow these instructions could result in death or serious injury from explosion or fire.
- Read and follow all warnings and instructions carefully before assembling or using this appliance.
- Keep this manual for future reference. **SAVE THESE INSTRUCTIONS.**

! DANGER

CARBON MONOXIDE HAZARD



This appliance can produce carbon monoxide, an odorless toxic gas. Using it in an enclosed space can kill you. Never use this appliance in an enclosed space, such as a camper, tent, car, or home.

This appliance is not intended for and should never be used as a heater.

Meco Corporation strives to be a quality supplier of consumer products.

If we omitted any parts needed for assembly or you need troubleshooting information, please contact us using our toll free number or visit our website.

It is important to register your grill and retain your receipt.

1-800-251-7558

8 am - 4:00 pm E.S.T. Mon. - Fri.

1-423-639-1171 (Telephone)

1-423-639-2570 (Fax)

www.mecocorp.com

Consumer Service Department

MECO CORPORATION

1500 Industrial Road

Greeneville, TN 37745 USA

! WARNING

To reduce the risk of serious bodily injury or death:

- Never use a grill unless all parts of the unit are firmly in place and the grill is stable.
- Do not wear loose clothing (example: hanging shirt tails, clothing with frills, etc.) around a grill while in use or hot.
- Do not touch hot surfaces. Use heat resistant gloves, long-handled tongs, or barbecue mitts at all times since the grill will become very hot.
- Do not allow children to operate or play near a grill. Keep animals and bystanders out of the grill area. Do not leave grill unattended.
- Do not attempt to extinguish a grease fire with water or other liquids. Have an ABC fire extinguisher nearby.
- Always have an ABC fire extinguisher, baking soda, a bucket of sand or a garden hose ready in case of an uncontrolled fire.
- The use of accessory attachments, not recommended by Meco, may cause injuries.
- Never move a hot grill or leave grill unattended during operation. Extinguish coals or unplug grill, close hood and let cool before moving.
- Store grill out of the reach of children. Use weatherproof cover for outdoor storage.

! WARNING

To reduce the risk of cut, pinching or other bodily injury:

- Wear protective gloves when handling or cleaning parts that could have sharp edges.
- Use care during assembly, use and cleaning.



WARNING: Cancer and Reproductive Harm -

www.P65Warnings.ca.gov

WARNING - Charcoal

To reduce the risk of serious bodily injury or death:

- Never use gasoline, kerosene, alcohol or other volatile fluids as a starter. They can explode.
- Do not use charcoal grill as a space heater.
- Do not use aerosols or store flammable liquids or materials near this charcoal grill. Cap lighter fluid immediately and place a safe distance from the grill.
- Instant light briquettes already have the starter blended in. Do not use lighter fluid, an electric starter, solid, or metal chimney starters.
- Do not add more instant light briquettes once the fire has been lit. To avoid flame-ups, unpleasant fumes and odors, add regular charcoal briquettes if needed.
- Once the grill has been lit, do not touch the charcoal briquettes/wood chunks to check if hot.
- Never add lighter fluid to already hot or warm coals.
- Do not close hood on flaming charcoal. If closed and re-opened, the flames could leap out
- Do not lean your body over the charcoal grill when lighting it, while it is hot or is in use.
- Do not move a charcoal grill when in use or hot.
- Allow grill to cool before handling parts or cleaning.
- To avoid an accidental fire, allow coals to burn out completely and let the ashes cool for 48 hours before disposing of them.

WARNING - Electric

To reduce the risk of serious bodily injury or death:

- To protect against electric shock, never immerse cord, plugs, or electric heating element in water or any other liquid. Do not clean this product with water spray or the like.
- Never leave heating element on when you are not cooking. Unplug grill from outlet when not in use or before cleaning. Allow grill to cool before cleaning or removing parts.
- Never operate any appliance with damaged electrical components or after the appliance has malfunctioned. Inspect regularly supply cord and connections. If Cord, Element or Control is damaged or worn, it must be replaced with an OEM Meco part. Contact Meco Customer Service Department with your grills Serial Number and your Proof of Purchase.
- Never move a hot grill or leave grill unattended during operation. Unplug grill, close hood, and let cool before moving.
- Never use an electric grill in the rain, sleet, or snow.
- Never use electric grill near combustible or flammable materials; or place on or near a hot gas or electric burner, or in a heated oven. Never let cord touch hot surfaces.
- Use only a properly grounded 110-120 VAC outlet. Always attach plug to appliance first unless permanently attached. Then plug cord into the wall outlet. Turn Control knob(s) to OFF POSITION before unplugging electric grill.
- Electrical supply cords should always be secured during appliance operation to protect against personal injury or product damage. Never let cord hang over edge of table or counter where it can be pulled or tripped over or touch hot surfaces.
- The use of longer detachable power supply cords or extension cords is not recommended. However, if such cords are used, they must be the same 3-wire grounded type and the electrical rating at least as great as the appliance cord (14AWG). Outdoor extension cords should be used with outdoor use products and are surface marked with suffix letters "WA" and with a tag stating "Suitable for Use With Outdoor Appliances". Length of the cord should be kept short as possible.
- The use of alcohol, prescription or non-prescription drugs could impair the consumer's ability to properly assemble or safely operate this appliance.

WARNING USING CHARCOAL

To reduce the risk of serious injury or death from explosion or fire:

- Be careful when burning charcoal to avoid getting burned from flame, heat or hot coals.
- Be aware of the wind blown sparks.
- The use of alcohol, prescription or non-prescription drugs could impair the consumer's ability to properly assemble or safely operate this appliance.

WARNING SELECTING A LOCATION

To reduce the risk of serious injury or death from explosion or fire:

- Locate your grill in an open area away from buildings, dry leaves, or brush, and at least 10 feet away from your house or building.
- Always make sure the grill is on a level, stable surface and not tilted toward the front or back.
- Do not use the grill in a garage, breezeway, carport, porch, high traffic area, on or under any surface that can catch fire.
- Do not use a charcoal grill indoors, on recreational vehicles, or on boats.

WARNING STARTING A FIRE

To reduce the risk of serious injury or death from explosion or fire:

- Make certain you leave the Hood and Body off until the flames have died down.
- Should electrically operated starters be used, be sure they are properly grounded according to local codes. Electrical cords should be placed away from walkways or traffic areas.
- Do not use lighter fluid, an electric fire starter solid, or chimney starters with instant light charcoal. This could cause flame-ups, unpleasant fumes and odors.
- Use barbecue mitts and long handled tongs to spread out the hot charcoal.
- If there is any type of fire that threatens either personal safety or property, call the fire department.

WARNING COOKING ON YOUR GRILL

To reduce risk of burns from the hot air and steam trapped inside, open the Hood carefully when grill roasting.

- Do not grasp the Cooking Grid with your hands while it is hot. Use barbecue mitts for handling.
- If flare-ups occur, close the Vents for at least one minute to stop flare-up. Do not use water.

WARNING END OF COOKING SESSION

To reduce the risk of serious injury or death:

- Allow the grill to cool completely before cleaning, transporting or storing.
- Empty and clean the Fire Bowl after each cooking session so excessive grease and ashes do not accumulate. See Cleaning instructions on next page.
- Store your charcoal grill in a cool dry place.
- Do not store charcoal and lighter fluid indoors.
- Store out of the reach of children.
- Do not store additional charcoal and lighter fluid under or near the grill while it is hot.
- To avoid a fire or explosion, do not store charcoal or lighter fluid near a heat source.
- Always cap the lighter fluid when not in use.

Preparation for Assembly

TOOLS NEEDED: Phillips head Screwdriver and a 3/8" open end wrench or a pair of pliers.

LAY OUT AND IDENTIFY ALL PARTS. DO NOT DISCARD CARTON OR PACKING UNTIL YOUR GRILL IS COMPLETELY ASSEMBLED. READ ALL ASSEMBLY AND SAFETY INSTRUCTIONS IN THE OWNER'S MANUAL BEFORE YOU START.

If you need replacement parts, refer to the Parts List to find the exact parts you need. If you have any questions or need help, contact Customer Service at 1-800-251-7558 or go to www.mecocorp.com. Be sure to have the grill model number. If you need a replacement part under warranty, a proof of purchase will be necessary. You will be asked to forward your proof of purchase via e-mail or fax to 423-639-2570 along with your model number.

It is important to register your grill and retain your receipt.

Parts List for Models 5025 and 5029

Parts are common to both the Electric and Charcoal Models except where noted.

ITEM	DESCRIPTION	QTY	
		5025	5029
1	Bolt 10-24 x 1/2"	18	19
2	Lock Nut 10-24	18	18
3	Screw #8 x 5/8"	6	6
4	Grid Bracket	3	3
5	Pan Bracket	3	3
6	Wing Nut	-	1
7	Wood Handle	3	3
8	Handle Bracket	3	3
9	Leg	3	3
10	Heat Indicator	1	1
11	Hood	1	1
12	Cooking Grid	2	2
13	Water/Charcoal Pan	2	1
14	Body Assembly Charcoal	1	-
14	Body Assembly Electric	-	1
15	Element Control Probe	-	1
16	Element	-	1
17	Reflector pan	-	1

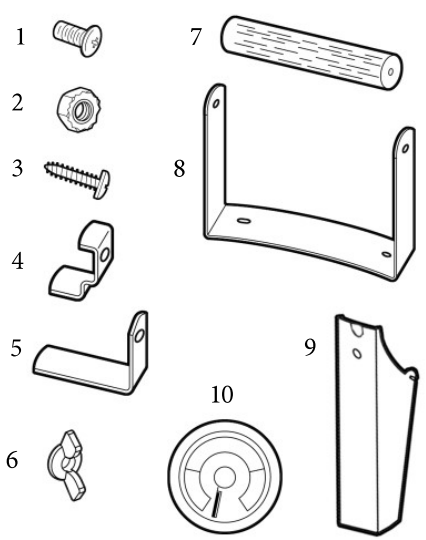
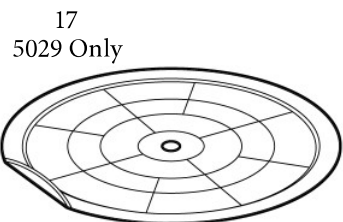
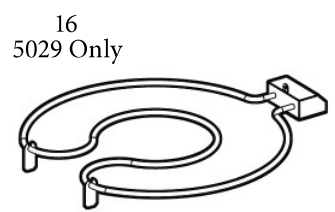
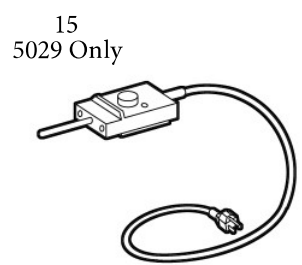
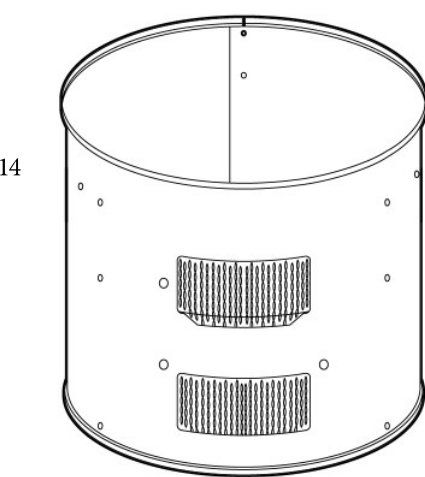
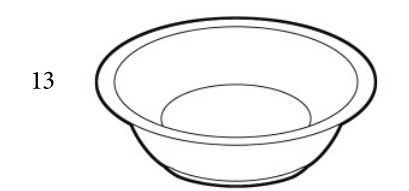
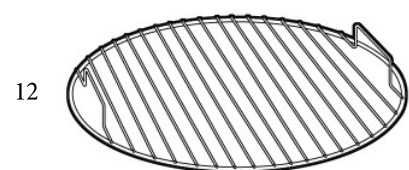
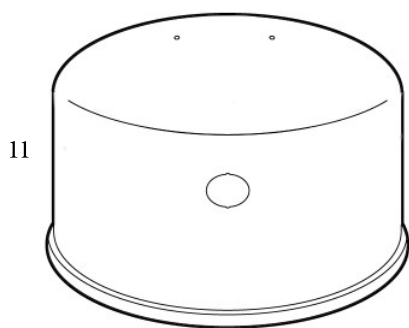

5025 Charcoal Water Smoker Assembly

5029 Electric Water Smoker Assembly

Step 1

Body Handle Attachment

A. Align Handle Bracket (8) over one pair of holes near the top of the Body Assembly. Insert a 10-24 x 1/2" Bolt (1) through each hole in the Bracket then through the Body. Fasten in place with a Lock Nut (2) and tighten. Repeat for Handle Bracket on opposite side of Body Assembly.

B. Place Wood Handle (7) inside of a Handle Bracket. Insert a #8 x 5/8" Wood Screw (3) through Handle Bracket into hole in the end of the wood handle and tighten. Repeat for the other end of Handle. Install Wood Handle in Handle Bracket on opposite side of Body Assembly.

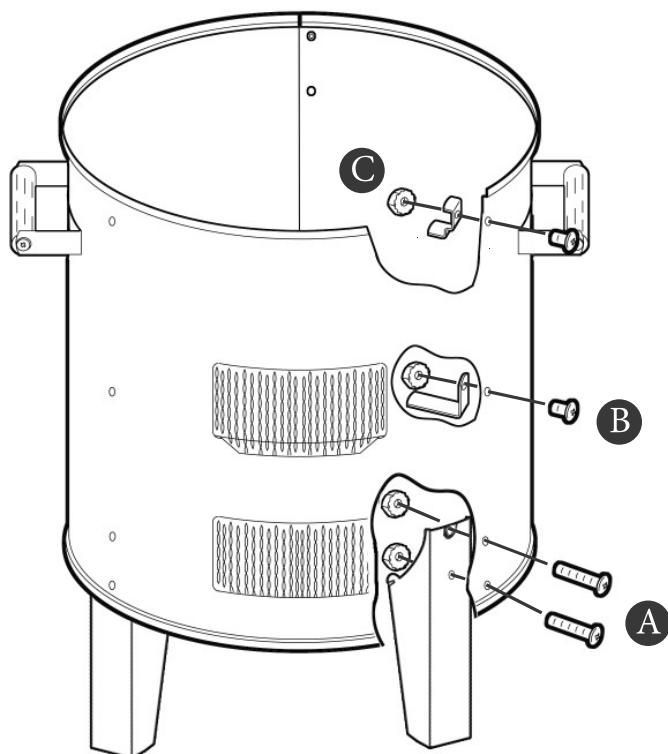
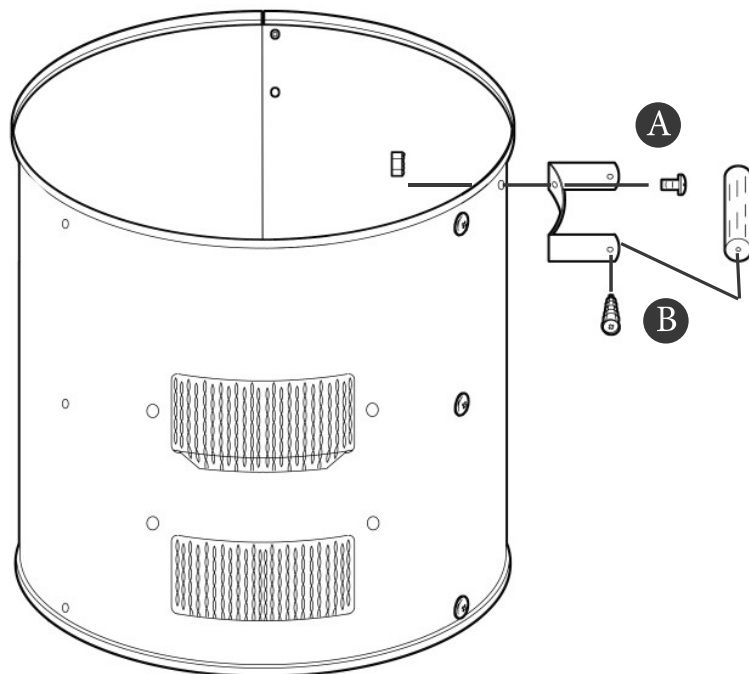

Step 2

Leg and Bracket Attachment

A. Turn the Body (14) of the smoker upside down; bottom edge is farthest from the Handles, shown upright in the illustration for Steps B & C. Insert a 10-24 x 1/2" Bolt (1) from the outside through one of the holes near the bottom of the Body and then through the Leg (9). Fasten in place with Lock Nut (2). Repeat with the second set of holes from the bottom. Repeat for the remaining two legs.

B. Insert 10-24 x 1/2" Bolt (2) from the outside through one of the holes near the center of the Body (14) then through the hole in a Pan Bracket (5). Fasten in place with Lock Nut and tighten. Long leg of Pan Bracket should be at the bottom. Repeat for the other two Bolts, Pan Brackets and Lock Nuts around the center of the Body Assembly.

C. Insert 10-24 x 1/2" Bolt (1) from the outside through one of the holes near the top of the Body Assembly then through the hole in a Grid Bracket (4). Fasten in place with Lock Nut (2) and tighten. Long leg of Grid Bracket should be at the bottom. Repeat for the other two Bolts, Grid Brackets and Lock Nuts around the top of the Body Assembly.

Step 3

Hood Assembly

A. Insert a 10-24 x 1/2" Bolt (1) through one bottom hole in the Handle Bracket then through the remaining small hole in the top of the Hood. Fasten with a Lock Nut from inside hood. Repeat for other side of handle bracket. Tighten both sides securely.

B. Place the Wood Handle between the upright legs of the Handle Bracket so the holes in the wood handle line up with the holes in the Handle Bracket. Fasten in place with one #8 x 5/8" Screw (3) in each side.

C. Align the bumps on the Heat Indicator (10) with the notches in the circular hole located on the front of the Hood. Insert the Heat Indicator and rotate 1/4 of a turn until the dial faces upright. If needed, assist the turning with your other hand on the inside of the Hood

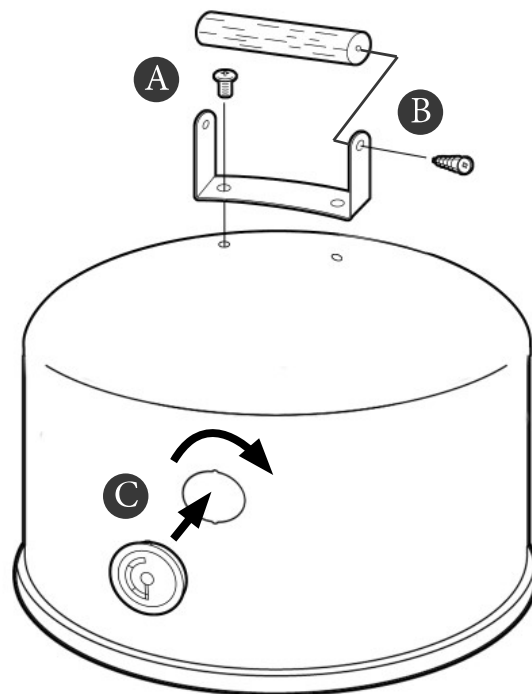

Heat Indicator

The purpose of the Heat indicator is only to give a RELATIVE indication of how the smoker is performing and not the temperature of the meat. For example: "Has the power gone off?" or "Has the charcoal died out?" The Heat indicator reading is influenced by many variables such as outside temperature, windy conditions and rain. The actual internal smoker temperature may vary considerably. This is not a problem as the goal is "Low and SLOW". The "Smoke Cooking" section gives directions that allow your smoker to perform consistently at the correct temperature with great results.

Step 4

Element Installation (5029 ONLY)

A. Align the notches of the Reflector Pan (17) with the top of the Legs. Push the Reflector Pan down over the legs.

B. Install Electric Element (16) by inserting the box shield through the rectangular hole in the Body from the inside. The tab on the box shield should be facing up and the "feet" on the element coil should rest on the reflector pan (17).

C. Insert 10-24 x 1/2" bolt (1) through the hole in the Body then through the tab on the box shield. Fasten in place with Wing Nut (6) and tighten. Do not overtighten.

D. When ready to use, plug Element Control Probe (15) into the box shield extending out through the Body. Be sure the Probe is seated firmly and completely into the box shield. If necessary, grasp the bottom rim of the body to allow the Probe to be completely seated.

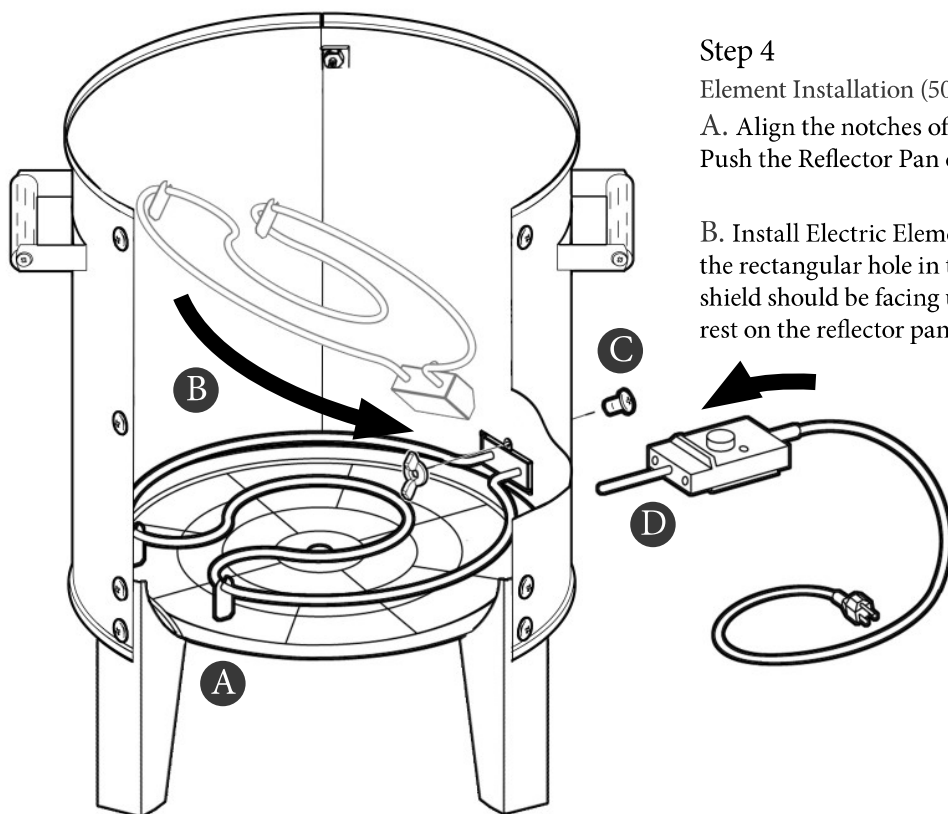

Step 5

Internal Component Installation

A. (5025 Charcoal) Place one of the Water/Charcoal Pans (13) inside of the smoker and lower it until it rests on the Legs at the bottom of the Body.

B. Place Water Bowl (13) inside Body Assembly so round edge rests on Pan Brackets at center of Body. Place one Cooking Grid (12) over Water Pan. NOTE: Water Pan and bottom Cooking Grid share the same Brackets. Place the other Cooking Grid on Grid Brackets at top of Body Assembly. Cooking Grid should rest on long/bottom leg of Grid Brackets.

A. (5029 Electric) Install Reflector Pan and Element as described in Step 4.

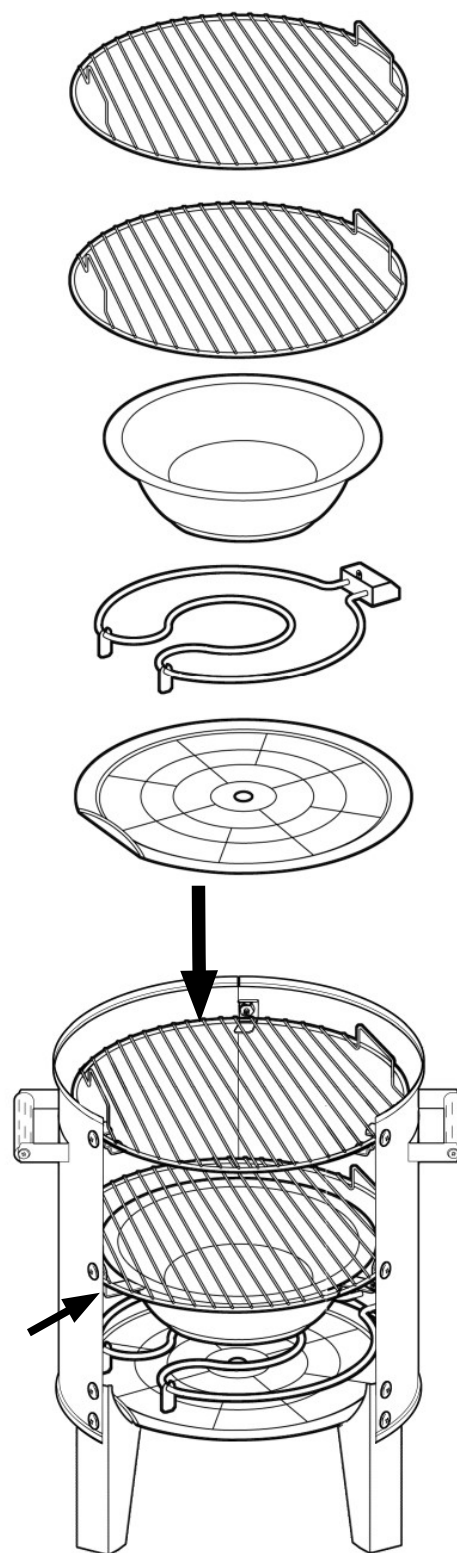
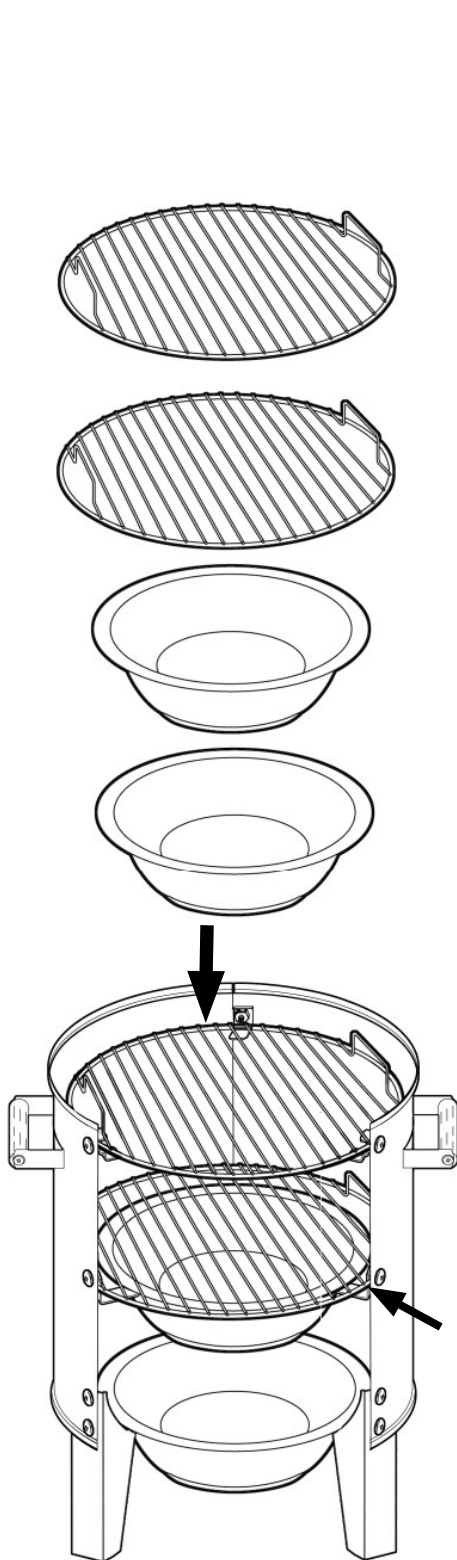

NOTE:
Water Pan and bottom Grid share the same Brackets.

Quick Tips for Use and Care

Break-in

To get the best flavor from your first cook and remove any manufacturing oils, follow the steps below to “Break-in” your new grill.

For the 5029 Electric model, break-in the element to remove the new appliance smell before cooking for the first time. Once assembled, plug in the element, set the control on high and burn it for about 10 minutes with the hood off.

To break-in the 5025 Charcoal model, follow the charcoal lighting instructions to start approximately one pound of charcoal. When flames go out and charcoal has started to turn gray, place the hood on the body. Allow the charcoal to burn completely. Allow the smoker to cool then empty the ashes and you are ready to reload with charcoal and cook.

Cooking on the ELECTRIC Smoker/Grill

Cooking with the electric model is similar to cooking with the charcoal model but is far simpler as no lighter fluid or charcoal is needed and the element is very consistent. Cooking times may vary slightly as the electric element may be slower to heat back up after the hood has been opened. When using the Electric Water Smoker you will need to cook on High unless you are only warming.

ALWAYS use a meat thermometer to check for doneness. The Quick Glance Cooking Guide at the end of the manual lists safe temperatures.

Heat Indicator

The purpose of the Heat indicator is only to give a RELATIVE indication of how the smoker is performing and not the temperature of the meat. For example: “Has the power gone off?” or “Has the charcoal died out?” The Heat indicator reading is influenced by many variables such as outside temperature, windy conditions and rain. The actual internal smoker temperature may vary considerably. This is not a problem as the goal is “Low and SLOW”. The “Smoke Cooking” section gives directions that allow your smoker to perform consistently at the correct temperature with great results.

Doors

The Doors in the Body may be used to control the amount of smoke and temperature as well as to add water or more wood chips. Open the Doors part way to increase the charcoal temperature or lower the temperature on the electric model. When using as a smoker, adjust in slight increments to achieve a thin blue stream of smoke around where the hood sits on the Body.

Clean-Up

Clean-Up may be made easier by spraying the Cooking Grid and Reflector Pan (on the electric model) with cooking spray before cooking. The Water Pan and inside of the Bowl may be lined with aluminum foil. Make sure you do not cover any of the vents.

After cooking, when grill has cooled down, wash the Cooking Grids, Reflector Pan on the 5029 electric - Charcoal Pan on the 5025, Water Pan and the outside of the smoker/grill with warm soapy water. The Electric Element may be wiped clean. DO NOT IMMERSE ELEMENT OR CONTROL IN WATER.

Wipe loose excess grease from the inside of the grill. DO NOT USE OVEN CLEANER! It is intended for the inside to become dark and smoky. This is similar to seasoning a cast iron skillet.

Storage

After you have cleaned your smoker, store it in a clean, dry area. Leave all the vents open so moisture does not collect inside. If you store your smoker outside, close the doors to keep the rain out. To maintain the condition and extend the life of your smoker, we strongly recommend that the unit be covered when stored outside for any length of time, especially during the winter months.

If storing your 5029 Electric smoker outside, detach power cord/control and store indoors.

Contact Customer Service at 1-800-251-7558 or go to www.mecocorp.com to find out about our grill covers and other accessories.



WARNING

To reduce the risk of serious bodily injury or death:

- Do not move the grill when in use or hot.
- Allow the grill to cool completely before cleaning, transporting or storing.

Basic Keys to Successful Smoke Cooking

“Low and Slow” is the key for the simple creation of incredibly juicy, smoky meats!

SCHEDULING:

Long, slow smoke cooking is such a change from our usual hurry-up way of life that it may take some gettin’ used to. Food and recipe choices can be as simple or as time consuming as you wish but the cook time will always be longer than normal grilling or even oven cooking.

It is a good idea to set yourself a countdown so your food will finish cooking before your scheduled meal time. Cooks that do not plan ahead may find themselves with a yard full of hungry guests if the food comes out of the smoker two hours after they were ready to eat.

Base your countdown on the longest cooking time shown on the Quick Glance Cooking Guide or recipe. Count backward from the time you want to eat then add another hour to start the charcoal (or plug in and warm up the electric model), take the meat out of the refrigerator to take the chill off and generally get everything ready to cook. This first hour of preparation is the most work you will have to do when smoke cooking.

TIMING:

Notice that there are ranges of one or two hours in the recipes on the Quick Glance Cooking Guide. This is because there are so many factors that can speed up, or more likely slow down the rate of smoke cooking. Wind, the starting temperature of the food, outside temperature, relative humidity, the number of times you lift the hood, the temperature of the water in the pan, the thickness and weight of the food can all have an effect on the cooking time so recommended cooking times are approximate. The only way to be sure the food is done is to check the temperature with a meat thermometer. Another of the many great things about smoke cooking is that there is VERY little risk of overcooking in a water smoker. When the water pan is in place and filled with water it keeps the heat low and even so that at the end of long cooking sessions the food will stay hot and moist for hours.

If the outside temperature is below 55-60 degrees F, you are cooking above 4000 feet or it is windy, allow extra time for smoking. If you forget to take the meat out of the refrigerator for 30 minutes or so to remove the chill, allow extra cooking time. Meat must be completely thawed before putting it in to smoke cook.

TESTS FOR DONENESS:

ALWAYS USE A MEAT THERMOMETER TO TEST FOR DONENESS! Refer to your recipe or the Quick Glance Cooking Guide to determine the minimum cooking time and temperatures for doneness. Only at the end of the recommended minimum time should you lift the hood to check the temperature of the meat. DO NOT LIFT THE HOOD except to check for doneness as heat will be lost and the cook time will be lengthened. Add at least 15 minutes to the recommended cooking time for each time you lift the hood. Always be sure to insert the meat thermometer into the meat so the tip is in the center of the largest muscle, away from bone or fat.

Smoked foods do look a bit different from oven or grill cooked foods so your eye can not always judge doneness. This and the long cooking time make it essential to use a meat thermometer. Smoked poultry, for instance, will usually look slightly pink especially around the joints and just under the skin while the skin will be a crispy dark brown. Pork will also show a pink color even though it is done. Different rubs and glazes will produce a range of surface colors from gold to a black “bark” on long smoked pork butts.

FOOD SAFETY:

- Always marinate food in the refrigerator, not on the counter.
- Cooking utensils (spatulas, forks, tongs) that were used to handle/flip food while cooking should be thoroughly washed before using to remove cooked food from the grill. Bacteria transferred from the uncooked food could be transferred to the finished food during this last step. Any bacteria transferred during the cooking process will be killed by the heat of grilling.
- Smoke food to a safe minimal internal temperature. See the Quick Glance Cooking Guide.
- Do not place cooked food on the same plate that was used to take the raw food to the grill unless the plate was thoroughly washed.
- Keep meats hot in the smoker for second helpings.
- When no more meat will be served, chill promptly. Refrigerate meat and poultry within 2 hours of removing it from a smoker. Cut the meat or poultry into smaller portions or slices, place it in shallow containers, cover, and refrigerate. Use it within 4 days or freeze for later use.
- Cook turkeys unstuffed. If stuffing is desired, prepare and wrap in foil to cook along side of the bird.

WHAT IF?...

Even the best planned schedule can go astray so here are some suggestions for those rare occasions:

- Try to always have some appetizers or a salad to serve first so you have flexibility in your serving time.
- If the food is cooking too slow and guests have consumed all of the appetizers, try one of the following:
 - Remove the water pan to allow all the heat from the charcoal to get to the meat.
 - Cut large pieces of meat into smaller sections. They will not be as juicy as when cooked whole but will finish faster.
 - Wrap the meat in foil and move to an oven pre-heated to 400 degrees.
- If the food has cooked faster than planned and is beginning to dry out:
 - Baste with juices from the water pan and wrap in foil. Leave it on the cooking grid to stay warm until serving time.
 - If serving time is more than an hour away, in addition to basting and wrapping in foil, put some ice in the water pan and fill with cold water.

CHARCOAL:

Cooking with charcoal is not an exact science. Many factors can affect temperatures and cook times such as type of charcoal, condition of charcoal (fresh and dry or old and damp), outside temperature, humidity, windy conditions, rain and elevation above sea level. Pay close attention to these factors during your first few uses and experience will become your best guide. The following information will give you a good reference point from which to start.

Most charcoal briquettes average about 15 - 20 briquettes per pound. Always use at least 5 - 6 pounds. Bigger cooking jobs need more charcoal so follow recipes or refer to the Quick Glance Cooking Guide to determine the amount needed until you are experienced enough with your smoker to judge how much you will need. See the pictures below for guidelines for judging charcoal amounts.

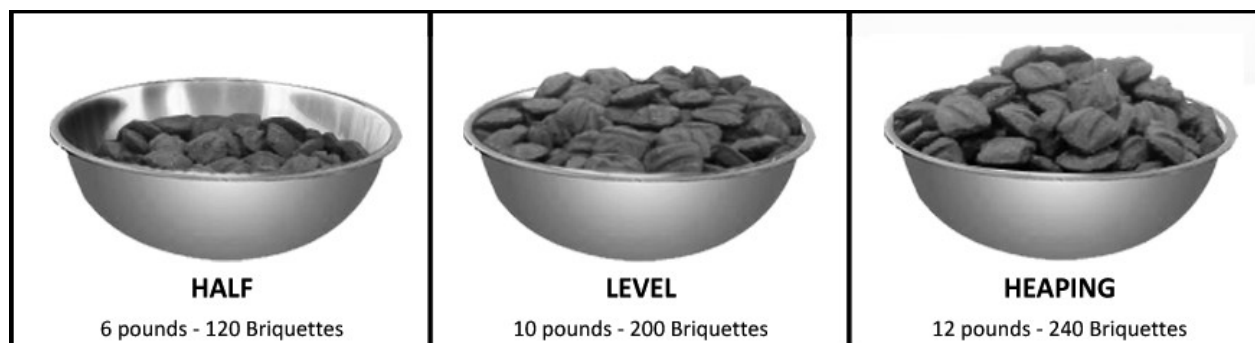

Always close unused bags of charcoal by rolling the top down tightly or store in a tight sealing plastic charcoal storage bin sold at most major retailers. Store in a dry place as charcoal that is left out in the rain or dew will not burn well.

WOOD:

The smokehouse flavor comes from the wet wood that you put on the burning coals or on the electric element. If the wood is not well soaked it will burn rather than smoking. Only use wood from deciduous trees (shed their leaves in the winter). NEVER use wood from evergreen trees such as pine. The resin in the evergreen wood will ruin the flavor and appearance of the smoked food. DO use mesquite, maple, hickory, pecan, apple, peach, pecan or other fruit or nut tree woods. Experiment with all of them to experience the variety of flavors possible with your smoker.

You can also cook foods with the low, moist heat produced with your water smoker and NOT use the wood. You will get the same juicy results but without the smoke flavor.

TIPS FOR SUCCESS:

- Always thaw meat thoroughly.
- Let meat stand at room temperature at least 30 minutes before cooking.
- Add more cooking time if it is windy or colder than 50 degrees F, you are cooking at a high altitude and each time you lift the hood.
- Do not lift hood to check for doneness until the end of the minimum cooking time listed in the Quick Glance Cooking Guide.
- Do not lift the hood to “peek” at the food thinking you are checking to be sure it is cooking! The best use of the temperature indicator on the body of the smoker is to assure yourself that the smoker is still cooking and to be sure there are no drastic fluctuations in temperature. Sit down, relax, enjoy your friends and family, let the smoker do its job and the cook will be the hero when the meat is done!

Smoke Cooking Instructions

GETTING STARTED:

When using either the 5029 Electric Water Smoker or the 5025 Charcoal Water Smoker, after the initial start up, the basic cooking methods are the same. “Low and Slow” is the key for the simple creation of incredibly juicy, smoky meats. Below are the basic steps for using your smoker. Following this section are more tips and recipes. There are also a great number of recipes and methods available online.

REMEMBER THE FOLLOWING REQUIREMENTS FOR SAFE, SUCCESSFUL COOKING:

- ALWAYS USE A MEAT THERMOMETER TO CHECK FOR DONENESS. The Quick Glance Cooking Guide at the end of the manual lists safe temperatures. The purpose of the temperature indicator is only to give a relative indication of how the smoker is performing and not the temperature of the meat. The actual cooking temperature is influenced by many variables.
- Soak wood chips or chunks in water for at least 4 hours (or best overnight) before cooking. The amount of chips or chunks to use is determined by the amount of smoke flavor you want and of the type of food being cooked.
- BEFORE USING YOUR CHARCOAL OR ELECTRIC SMOKER, READ ALL WARNINGS.

IMPORTANT NOTES:

Do not lift the hood except to check for doneness as heat will be lost and the cook time will be lengthened. Add at least 15 minutes to the recommended cooking time for each time you lift the hood.

Always cook on the high setting unless you are only warming. The temperature indicator in the body of the smoker is for reference only as it is on the side of the body and not on the surface of the meat.

MODEL 5025 CHARCOAL

STEP 1. After “break-in”, determine a safe location as described in the Warnings section at the beginning of the manual.

“Instant Lighting” charcoal is not recommended due to the potential of adversely effecting the smoke flavor.

With the Body of the smoker removed, place the Charcoal Ring in the bottom of the Bowl. Fill the Ring with the amount of high quality charcoal briquettes as recommended on the Quick Glance Cooking Guide for the type and weight of meat you are going to cook.

STEP 2. Following the directions and warnings provided by the lighter fluid manufacturer, sprinkle lighter fluid over the charcoal. Let the fluid soak in for about one minute. Light the charcoal and let it burn for about 30 minutes or until the briquettes are at least 80% covered with gray ash.

STEP 3. When ready to cook, add wood chunks on top of the charcoal using long handled tongs. Your own experience will help you decide how much wood to use to achieve the amount of smoke flavor you desire.

NOTE: Most meats only absorb smoke during the first half of the cook time. Periodically check that smoke is still coming out of from around the rim of the hood and add wood if the smoke appears to be stopping. A good starting point for timing the adding of chunks is to start with three 2” to 3” chunks. After 1 to 2 hours it should be time to add more chunks.

STEP 4. Fill the Water Bowl with HOT water and place it on the bottom Pan Brackets. Some recipes may use less water along with other liquids such as juice, beer or wine.

STEP 5. Put the Cooking Grid on the top Grid Brackets and place the meat on the Grid. If cooking on both Grids with different meats or pieces, decide which will require the longest cook time and least tending and place that loaded Grid directly on top of the Water Pan. Then place the other Cooking Grid on the top Brackets. If cooking individual pieces such as a cut up chicken, arrange the meat in a single layer with space between pieces to allow heat and smoke circulation.

STEP 6. Place Hood on Body and open the doors in Body slightly to create airflow/draft. This should produce a thin steady stream of smoke exiting around the rim of the hood. Cook for the length of time indicated in the Quick Glance Cooking Guide or per recipe. If cooking for more than 6 hours you may need to add water or charcoal. Water level and charcoal may be checked through the access doors in the body. Using an insulated mitt or pot holder, slide the door up until open. If water is needed, add with a watering can with a long spout or use a steel ladle. If charcoal or wood chunks are needed, use long tongs to gently place on top of the burning charcoal. DO NOT TOSS THEM IN as this will stir up ashes that will get on the meat. Additional charcoal should be started in a chimney starter and added after twenty to thirty minutes.

STEP 7. After allowing to cool for at least 24 hours, dump the ashes and wash the Water Pan and Cooking Grids with soap and water. See Clean-Up and Storage tips.

MODEL 5029 ELECTRIC:

STEP 1. After “break-in”, determine a safe location as described in the warnings at the beginning of the manual. Plug the Control cord into a grounded 110-120 Volt 15 Amp outlet. Turn the Control to High and warm up the smoker.

STEP 2. When you are ready to cook, place wood chips or chunks around the electric coils. If using chips, they should be spread under the element. Chips will produce more smoke quickly and are useful to give a heavier smoke flavor when smoking foods with shorter cook times. Wood chunks may be placed on or touching the elements coil and will provide longer lasting smoke. Your own experience will help you decide how much wood to use to achieve the amount of smoke flavor you desire.

NOTE: Most meats only absorb smoke during the first half of the cook time. Periodically check that smoke is still coming out of the damper vents and add wood if the smoke appears to be stopping. A good starting point for timing the adding of chunks is to start with three 2” to 3” chunks and keep the smoker on high. After 1 1/2 to 2 hours it should be time to add three more chunks. The first chunks do not need to be completely gone.

STEP 3. Fill the Water Bowl with HOT water and place it on the bottom Pan Brackets. Some recipes may use less water along with other liquids such as juice, beer or wine.

STEP 4. Put the Cooking Grid on the top Grid Brackets and place the meat on the Grid. If cooking on both Grids with different meats or pieces, decide which will require the longest cook time and least tending and place that loaded Grid directly on top of the Water Pan. Then place the other Cooking Grid on the top Brackets. If cooking individual pieces such as a cut up chicken, arrange the meat in a single layer with space between pieces to allow heat and smoke circulation.

STEP 5. Place Hood on Body and open doors in Body slightly to create airflow/draft. This should produce a thin steady stream of smoke exiting the around the rim of the hood. Cook for the length of time indicated in the Quick Glance Cooking Guide or per recipe. If cooking for more than 6 hours you may need to add water to the Pan. Water level may be checked through the access doors in the body. Using an insulated mitt or pot holder, slide the door up until open. If water is needed, add with a watering can with a long spout or use a steel ladle.

STEP 6. After allowing to cool completely, wash the Water Pan and Cooking Grids with soap and water. See Clean-Up and Storage tips. If storing smoker outside, detach power cord/control and store indoors.

THE STALL:

Virtually every cook new to smoking will experience The Stall, usually with much confusion and stress. The Stall is what occurs after your meat has been cooking for a couple of hours and the internal temperature reaches a certain point and “stalls”, not rising for at least a couple of hours depending on the cut and size. The stall is simply “evaporative cooling.” The meat is sweating, and the moisture evaporates and cools the meat. The start of the stall may vary from 150 to 170°F depending on the particular piece of meat (size, shape, surface texture, moisture content, injection, rub), and cooker (charcoal, electric, airflow, water pan and humidity), as well as the accuracy of your thermometer. The higher the cooking temperature, the shorter the stall, and in some cases, as you approach 300F, there may be no stall at all. However “Low and Slow” will produce the most tender results, so have patience! The stall takes the moisture out from the surface and just below it. This is part of the creation of the crusty, jerky like “bark” on the surface that adds to the texture and flavor of the finished product. Once the available moisture has evaporated the temperature of the meat will again begin to rise. To minimize the length of the stall, do not open the hood or baste during this time.

QUICK GLANCE COOKING GUIDE

ALWAYS FILL WATER PAN WITH APPROXIMATELY 5 QUARTS OF HOT WATER UNLESS A RECIPE INDICATES LESS

THIS SMOKER IS NOT RECOMMENDED FOR "COLD SMOKING"

Food and Weight	Temperature for Doneness ¹	Cooking Time (Hours) ²	Amount of Wood Chunks ³	Amount of Charcoal ⁴
BEEF (Venison, Boneless Game Roasts)				
3 - 4 lbs.	140° F Rare	3 - 4	5 - 6	Half to Level
5 - 7 lbs.	160° F Medium	5 - 6	8 - 9	Level
8 - 10 lbs.	170° F Well Done	7 - 9	11 - 12	Heaping
CHICKEN				
Fryers (2 - 2 1/2 lbs. each) 1 to 3 whole, split or cut up	165° F	4 - 5	7 - 8	Level
Roasters (5 - 7 lbs.) 1 or 2		6 - 8	10 - 11	Heaping
FISH				
Fillet (full grill)	Flakes separate with a fork. Flesh is opaque	2 - 3	3 - 4	Half to Level
Steaks		2 - 3	3 - 4	Half to Level
Pan Fish (whole)		2 - 3	3 - 4	Half to Level
Large Fish (whole - 6 lbs.)		3 - 5	4 - 7	Level to Heaping
HAM				
Cooked (all sizes)	140° F	3 - 5	4 - 7	Level
Fresh (10 lbs.)	170° F	7 - 10	11 - 12	Heaping
PORK				
Chops (6 - 8 lbs. - 1" thick)	145° F	3 - 4	5 - 6	Level to Heaping
Roasts (3 - 5 lbs.)		5 - 7	8 - 10	Heaping
Roasts (5 - 7 lbs.)		7 - 8	11 - 12	Heaping
Ribs (5 lbs.)	Meat pulls away from the bone	4 - 6	8 - 9	Heaping
TURKEY (UNSTUFFED)				
8 - 12 LBS.	165° F	7 - 9	11 - 12	Heaping
13 - 20 LBS.	DO NOT smoke a stuffed turkey	10 - 12	16 - 17	Heaping

¹ Temperatures are those recommended by the USDA Food Safety and Inspection Service

² Cooking times are approximate. Electric smoker times may be longer.

Always use a meat thermometer to check doneness.

³ Suggested amount of "tennis ball" size chunks. Experiment with different woods and amounts to taste.

⁴ A "Heaping" bowl of charcoal will last 5 to 6 hours. If cooking larger pieces that require more time, more charcoal should be started in a separate container at least 30 minutes before it is expected to be needed.

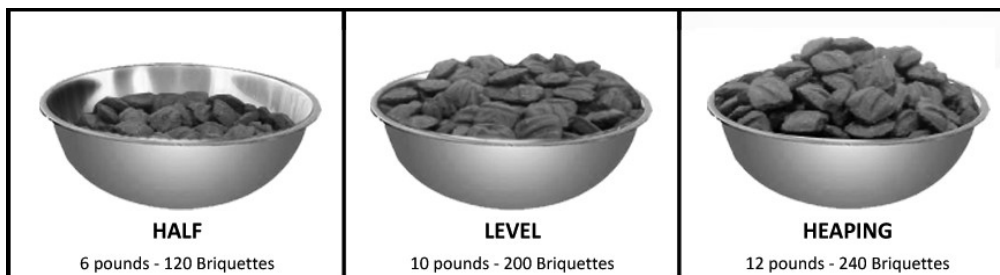

Basic Recipes for Smoke Cooking

EAST TENNESSEE PULLED PORK

1 pork butt (6-8 lbs)
Choice of wood chunks or chips (hickory chunks preferred)
Dry rub

Dry Rub: This is our basic recipe for dry rub. There are many rubs on the market, with a wide range of tastes, from dark and smokey to light and sweet to spicy hot. The dry rub will usually become black and crispy when smoked. This is referred to as “bark”. The bark is that little extra punch that compliments the pork. Don’t be afraid to see the outside of the pork butt black and crispy after cooking...this is a good thing!

1/2 Cup Brown Sugar
1 Teaspoon Garlic salt
1 Teaspoon Kosher salt
1 Teaspoon Paprika
1 Teaspoon Oregano
1 Teaspoon Cayenne
1 Teaspoon Cumin
1 Teaspoon Black pepper

Mix the rub ingredients in a bowl. If you plan to inject any sauces or juices into the pork with an injector, do so before you apply the rub. With the pork butt thawed, apply the rub evenly over the entire pork butt. Wrap with clear-wrap (or aluminum foil) tightly. Place in refrigerator overnight... 2 – 3 hours is fine, but 10 – 12 hours is best for full flavor. Remove from refrigerator and remove clear-wrap (or foil) 30 – 60 minutes before ready to place in smoker.

Pulled Pork:

When smoker is ready, add soaked wood chunks or chips to the ashed over coals or touching the electric element. Place the smoker body on the bowl and then place the water bowl (filled with hot water) in the smoker per instructions. Place pork butt in smoker and close vents to approximately 1/4” open (the temperature inside the smoker will sometimes go down when you add water or place meat inside the smoker).

Smoke the pork butt at 225 degrees for about one hour per pound of meat, until it reaches 190 degrees.

Remove the butt and allow to rest for 1/2 an hour to cool down. Pull the pork using your hands or forks and serve. Add your choice of barbecue sauce to the pork.

Minimum safe cooking temperature of pork is 160 degrees Fahrenheit. It is best for the pork butt to reach 190 – 200 degrees to make it easier to pull apart the meat and to render as much fat as possible. You can still pull the pork apart at 180 – 190 degrees, but you may have to trim some fat. You can also remove the pork butt at 170 – 180 degrees, but it is harder to pull apart.

“Stalling”:

Sometimes pork butts will reach 160 degrees quickly, but then stay at that temperature for a long time. If you find yourself falling short on time and you want the pork to reach 190 degrees, you can wrap the butt in foil and place in a pre-heated 350 degree oven to finish the process. When pork has reached about 165 degrees, it will usually stop absorbing any more wood flavor smoke.

This is a basic recipe for delicious pulled pork sandwiches. In East Tennessee, it’s not only about juicy smoked pork, but the side dishes that accompany it along with being surrounded with family and friends at the picnic table. So be sure to add your favorite cole slaw, baked beans, and corn-on-the-cob, with a glass of iced tea, and banana pudding for dessert. Enjoy your time with the family, and remind them this is southern country cookin’, the way it’s done in the southern Appalachians.

TURKEY or WHOLE CHICKEN:

Fresh or thawed turkey or chicken	Remove giblets and rinse bird with cold water.
Salt and pepper	Pat dry then coat outside with vegetable oil, margarine or butter. Sprinkle with salt and pepper (inside and outside).
Vegetable oil, margarine or butter	Let stand at room temperature (no more than 30 minutes) while preparing the
5 quarts hot water (more if cook time will be over 5 hours)	smoker per the “SMOKE COOKING” section of the manual.
1-2 wood chunks per pound of bird	
Juice or herbs if desired.	

When the smoker is ready, place 3 chunks of soaked wood on the ashed over coals or touching the electric element. Place the body on the bowl then fill the water bowl with 5 quarts hot water and place in the body per instructions. Juice such as apple may be added to the water bowl in place of some of the water. Herbs such as rosemary may also be added to the water bowl for a slight variation in flavor. Cover and smoke cook per the Quick Glance Cooking Guide or recipe. Monitor the smoke per the instructions and add chunks as needed to maintain. If the bird size requires cooking more than 5 hours, check the water level and fill as needed (with HOT water to keep the temperature up). Cook until a meat thermometer inserted in the center of the thickest part of the thigh away from the bone indicates 165 degrees. (Do not check the temperature until the shortest recommended cook time has been reached.)

SMOKED SALMON:

1 or 2 large skin-on salmon filets (2 to 4 pounds)

Choice of wood chunks or chips (alder and apple are popular)

BRINE:

1/2 gallon water

1/2 cup kosher salt

1/2 cup white sugar

1/2 cup brown sugar

Lemon and or black pepper to taste

1 Tbs dry crab/shrimp seasoning (optional)

2 cloves garlic, crushed or to taste

3 or 4 lemons, sliced and crushed

1 yellow onion, sliced

Mix the brine ingredients in a large bowl or plastic storage container. Do not use aluminum.

Rinse the salmon, place in the brine and cover or seal. Place in the refrigerator and let soak for 2 to 24 hours. The longer the soak time, the more salty flavor from the brine will be absorbed.

Remove the salmon from the brine and pat dry. (Save the brine) Place on smoking rack skin-side down in front of a fan on high for about an hour to form a "pellicle" on the surface of the salmon.

Add the remaining brine and hot water to the water pan to equal about five quarts or a full pan.

When the smoker is ready, place 3 chunks of soaked wood or chips on the ashed over coals or touching the electric element. Place the body on the bowl then place the water bowl in the body per instructions. place the cooking grids with the filets on the brackets. Cover and smoke cook about 2 - 3 hours until a meat thermometer indicates a temperature of at least 145 degrees and the flesh is opaque and separates easily with a fork. (Do not check the temperature until the shortest recommended cook time has been reached. Smoke longer for a firmer, dryer, smokier salmon that is good mixed with cream cheese as a spread or dip.

Check www.mecocorp.com for more Tips, Recipes and Links.

For more recipes, updates and tips follow us on:

Facebook at www.facebook.com/americanagrills

Instagram at www.instagram.com/americana_grills

Pinterest at www.pinterest.com/mecocorporation/americana-grills/

Youtube at www.youtube.com/c/AmericanaGrills

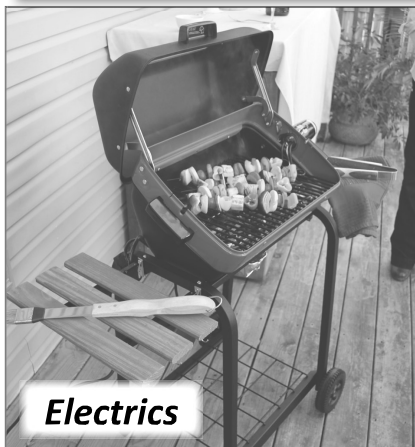
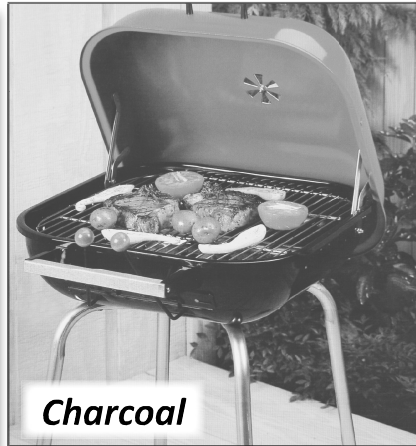

*Meco Corporation
Manufacturing Grills Since 1969
Electrics, Smokers, & Charcoal
Your Style, Your Choice!*

*To validate your warranty, register your grill at www.mecocorp.com
Replacement parts require proof of purchase. Please save your receipt.*