

This Owner's Manual is provided and hosted by [Appliance Factory Parts](#).

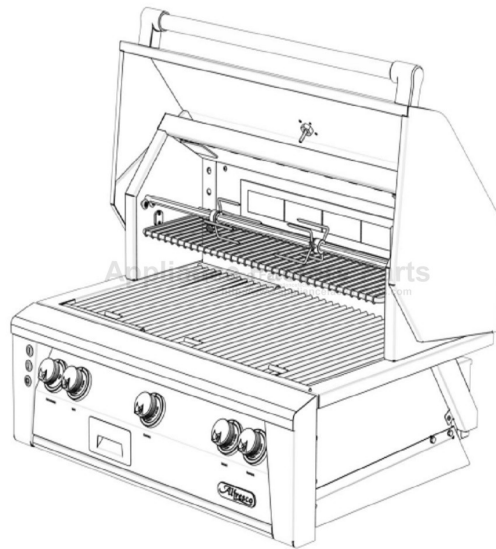

# Alfresco ALXE36SZ Owner's Manual

[Shop genuine replacement parts for Alfresco  
ALXE36SZ](#)



[Find Your Alfresco Grill Parts - Select From 126 Models](#)

----- Manual continues below -----

# Alfresco™

Open Air Culinary Systems

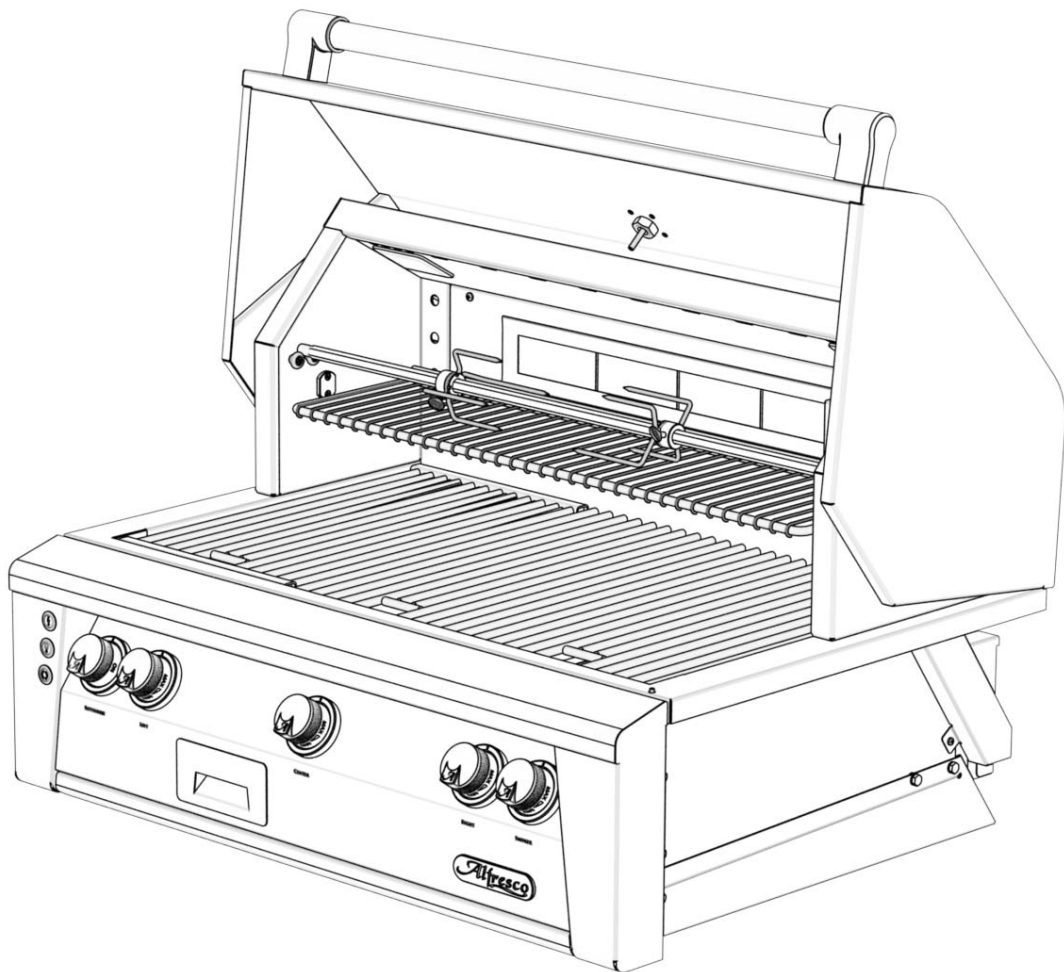

***ALXE-36 & 36SZ Parts Manual***  
***Serial Numbers 18-00000 forward***

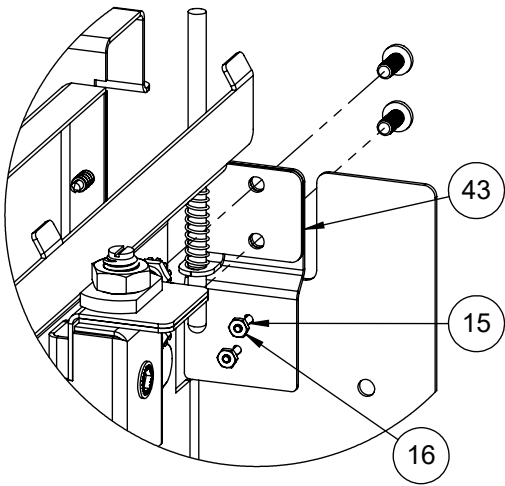

DETAIL OF HOOD SWITCH MECHANISM  
 FASTENERS (15) & (16) ARE FOR  
 ATTACHING THE SWITCH 210-0626  
 SEE ELECTRICAL COMPONENTS

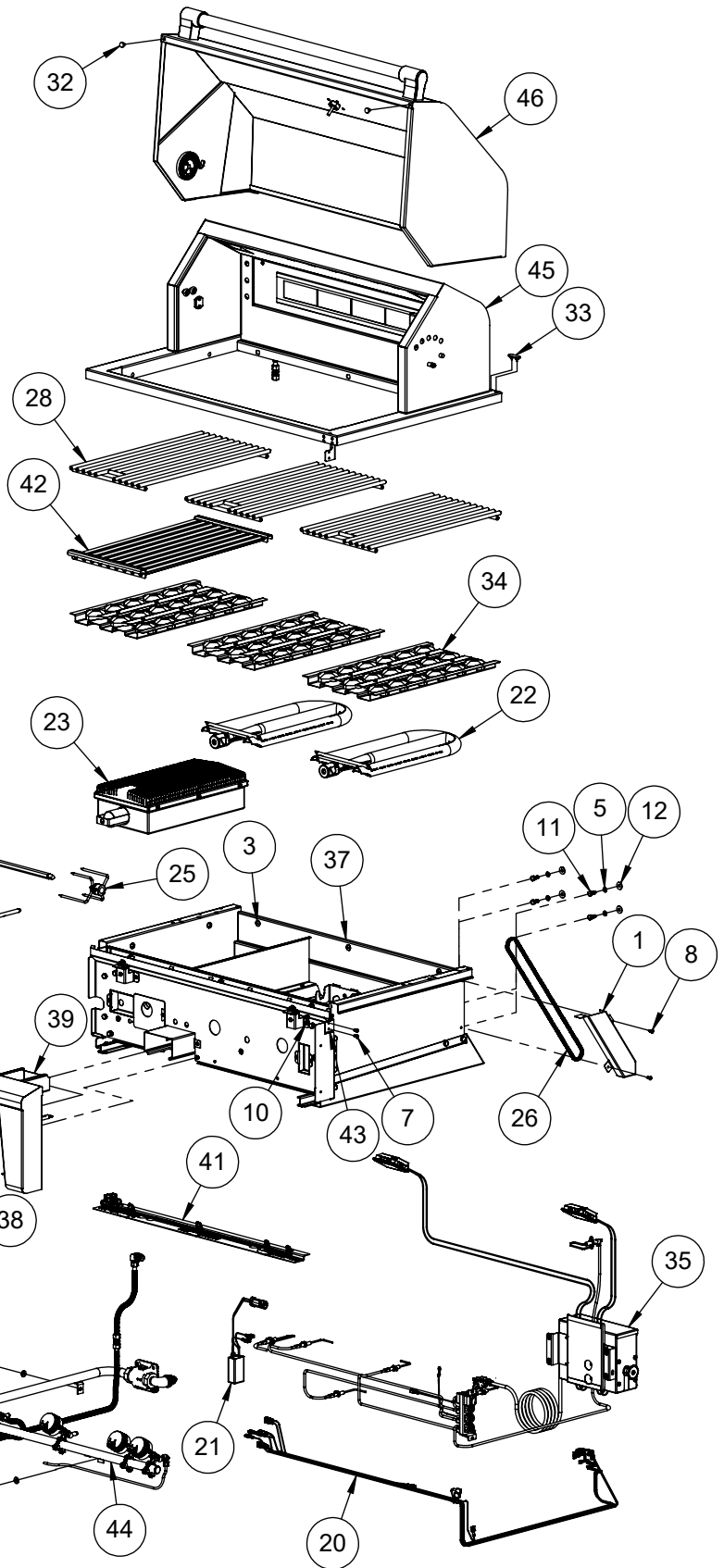

NOTE:

SEARZONE™ BURNER (23) AND GRILL (42) USED ON ALXE-36SZ

OTHERWISE, ONLY BURNER (22), GRILL (28) AND BRIQUETTE (34) USED ON ALXE-36

ITEM	PART NUMBER	DESCRIPTION	QTY
1	100-1877	ROTISSERIE CHAIN COVER	1
2	130-3069	FRONT PANEL	1
3	200-0057	SCREW 1/4-20 X 1/2 - TRUSS HEAD - PHILLIPS	10
4	200-0074	FLAT WASHER 1/4 TYPE A NARROW	3
5	200-0087	WASHER - 1/4" SPRING LOCK- REGULAR - SS	11
6	200-0089	BOLT - HEX HEAD 1/4-20 x 1/2" L	7
7	200-0100	SCREW 8-32 X 3/8" - PAN HEAD - PHILIPS - SS	2
8	200-0111	SCREW 8-18 X 1/2 - SELF TAP - 410 SS	2
9	200-0125	NUT THREAD CUTTER FOR 1/4" Ø STUD - SPEED NUT	2
10	200-0206	8-32 KEP NUT 18-8 STAINLESS	2
11	200-0219	HEX HD MACHINE SCREW 1/4-20 UNC X 5/8 LONG SS	4
12	200-0244	WASHER, FLAT 1/4 TYPE B - REGULAR, SS	4
13	200-0267	10-32 X 1/2 - PAN HEAD - PHILLIPS SCREW	6
14	200-0348	Screw 6-32 x 3/8 Flat Head (82°) phillips - Thread Cutter - #2 Drive - SS 410	10
15	200-0362	18-8 SS PAN HEAD SCREW 2-56 X 3/8	2
16	200-0363	18-8 SS HEX NUT 2-56	2
17	210-0583	SWITCH - IGNITION - MOMENTARY [ON]/OFF	1
18	210-0584	SWITCH - LIGHT - LATCHING [ON/OFF]	1
19	210-0585	SWITCH - ROTISSERIE - LATCHING [ON/OFF]	1
20	210-0606	WIRING HARNESS	1
21	210-0623	TRANSFORMER ASSY FOR ALXE	1
22	290-0038	BURNER - GRILL - "U" SHAPE	3
23	290-0052	ALFRESCO SEAR ZONE™ BURNER ASSEMBLY	1
24	290-0059	ROTISSERIE DRIP PAN	1
25	290-0096	FORK ASSEMBLY	2
26	290-0116	CHAIN - ANSI # 25 - 1/4" PITCH - .13" Ø X 1/8" ROLLER	1
27	290-0347	WARMING RACK - SS	1
28	290-0348	GRILL, BBQ - 10-7/16" WIDE - SS	3
29	290-0349	SPEAR - ROTISSERIE	1
30	290-0377	ALFRESCO RANGE LOGO	1
31	290-0388	ALFRESCO RANGE KNOB - BEZEL RING	5
32	290-0465	Bumper 600°F 1/2" dia x 5/32" head	2
33	290-0468	Bumper 600°F (obround), black	2
34	510-0677	BRIQUETTE TRAY ASSEMBLY	3
35	510-0678	ELECTRICAL COMPONENTS	1
36	510-0944	FRONT PANEL PERIMETER (ANGLED)	1
37	510-0945	FIRE BOX ASSEMBLY	1
38	510-0947	SMOKER BURNER ASSEMBLY	1
39	510-0949	SMOKER TRAY ASSEMBLY	1
40	510-0951	GREASE TRAY ASSEMBLY	1
41	510-0962	BULLNOSE LIGHT ASSEMBLY	1
42	510-0981	SEARZONE™ GRILL ASSEMBLY	1
43	510-1026	HOOD SWITCH MECHANISM	1
44	510-1038	GAS MANIFOLD ASSEMBLY	1
45	510-1204	REAR HOOD & RIM ASSEMBLY	1
46	510-1210	FRONT HOOD	1



THE INFORMATION CONTAINED IN THIS DRAWING IS THE SOLE PROPERTY OF SUPERIOR EQUIPMENT SOLUTIONS INC. ANY REPRODUCTION IN PART OR AS A WHOLE WITHOUT WRITTEN PERMISSION FROM SUPERIOR EQUIPMENT SOLUTIONS, INC. IS PROHIBITED.

**DRAWN BY:** N SILCOCK  
**CREATED:** 2/5/2016 1:38:01 PM

PROJECT TITLE:

**ALXE-36 AND 36SZ**

DRAWING TITLE:

DRAWING NO.:

**500-015**

SHEET 2 OF 2

NOTE:  
UNIQUE PARTS USED ON ALXE-36 MODEL

4 6 8

UNIQUE PARTS USED ON ALXE-36SZ MODEL

5 7 9 12

ITEM 1 IS USED FOR "U" BURNERS ONLY  
THEREFORE, ALXE-36SZ ONLY HAS TWO.

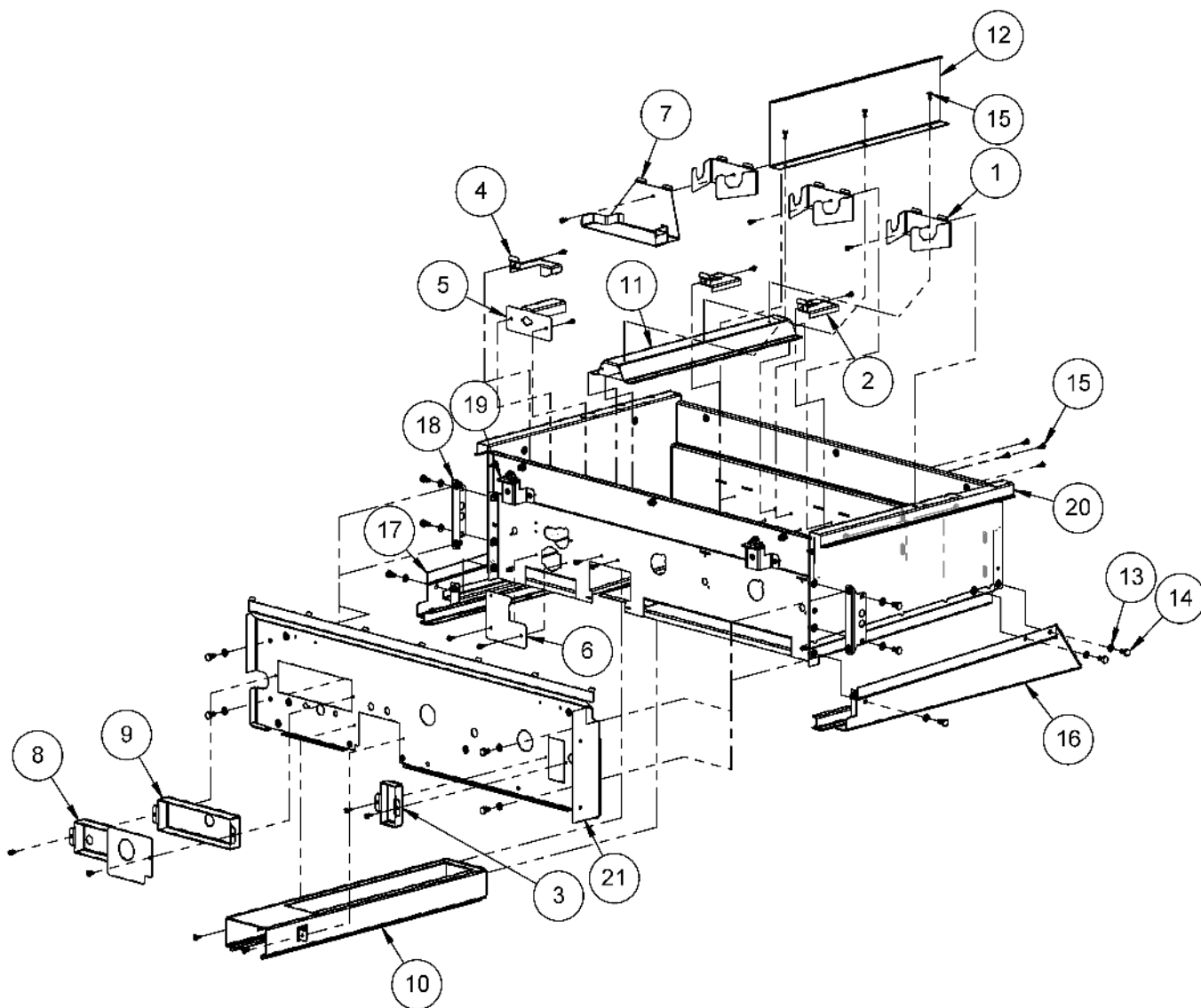

ITEM	PART NUMBER	DESCRIPTION	QTY
1	100-1846	U-BURNER BRACKET	3
2	100-1848	IGNITER SHIELD	2
3	100-1888	SINGLE VALVE FIREWALL COVE	1
4	100-2202	IGNITER SHIELD - LEFT SIDE	1
5	100-2210	SEAR-ZONE IGNITER BRACKET / SHIELD	1
6	100-2211	SEARZONE™ OPENING FIREBOX COVER	1
7	100-2212	SEAR-ZONE™ BURNER BRACKET	1
8	100-2213	DUAL VALVE FIREWALL COVER FOR U-BURNER	1
9	100-2214	DUAL VALVE FIREWALL COVE	2
10	100-2632	SMOKER BOX BODY	1
11	100-2653	SMOKER BOX TOP DIFUSSER	1
12	130-3042	SEAR ZONE BURNER SHIELD	1
13	200-0087	WASHER - 1/4" SPRING LOCK- REGULAR - SS	17
14	200-0089	BOLT - HEX HEAD 1/4-20 x 1/2" L	17
15	200-0111	SCREW 8-18 X 1/2 - SELF TAP - 410 SS	29
16	510-0502	GREASE TRAY SUPPORT - RIGHT SIDE	1
17	510-0503	GREASE TRAY SUPPORT - LEFT SIDE	1
18	510-0520	FIREWALL SUPPORT BRACKET ASSEMBLY	2
19	510-0904	FRONT PANEL MNTG BRKT	2
20	510-0946	FIREBOX - WELDED PARTS	1
21	510-0948	FIREWALL ASSEMBLY	1

ITEM	PART NUMBER	DESCRIPTION	QTY
1	100-2642	GREASE TRAY INSERT	1
2	200-0148	SCREW 10-32 X 3/4" - FLAT HEAD - PHILLIPS - 82° - SS	6
3	290-0119	ROLLER WHEEL - STAINLESS STL - 3/4" Ø	6
4	510-0952	GREASE TRAY - WELDED PARTS	1

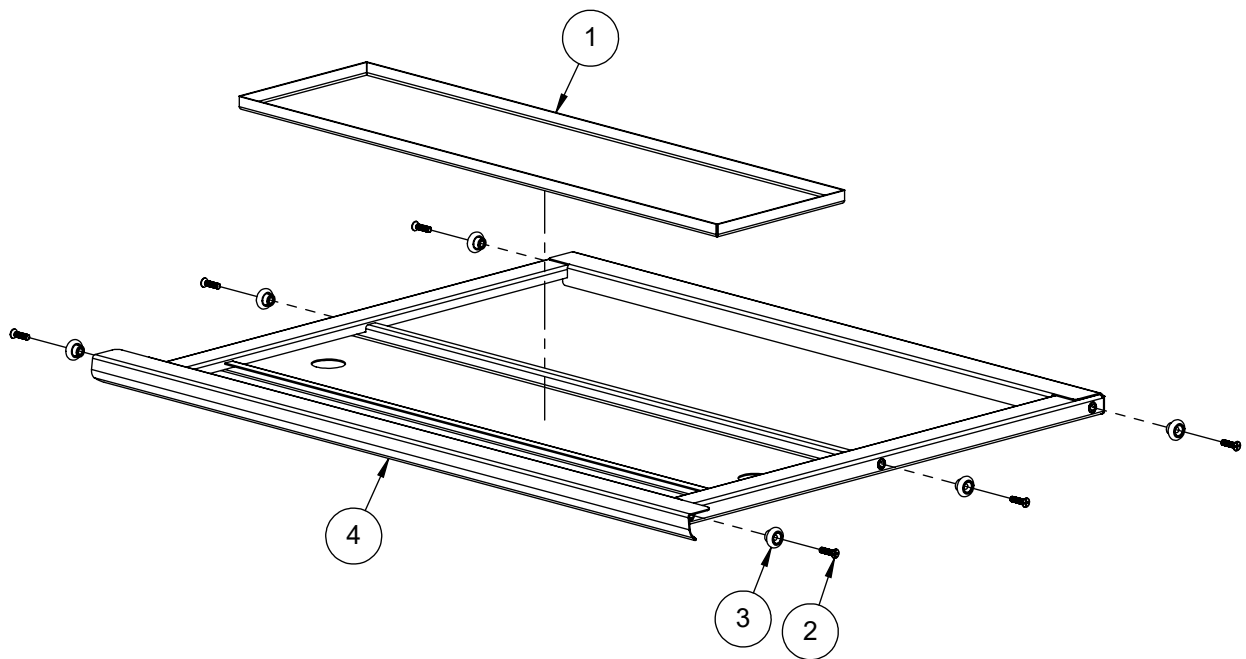

ITEM	PART NUMBER	DESCRIPTION	QTY
1	100-1092	ROTISSERIE GEAR COVER	1
2	130-2985	PIVOT PIN	2
3	200-0057	SCREW 1/4-20 X 1/2 - TRUSS HEAD - PHILLIPS	2
4	200-0062	10-32 X 3/4 - PAN HEAD - PHILLIPS SCREW	2
5	200-0087	WASHER - 1/4" SPRING LOCK- REGULAR - SS	4
6	200-0089	BOLT - HEX HEAD 1/4-20 x 1/2" L	4
7	200-0111	SCREW 8-18 X 1/2 - SELF TAP - 410 SS	1
8	200-0148	SCREW 10-32 X 3/4" - FLAT HEAD - PHILLIPS - 82° - SS	2
9	200-0361	SCREW 8-32 X 5/8" - FLAT HEAD 82° - PHILLIPS	4
10	290-0119	ROLLER WHEEL - STAINLESS STL - 3/4" Ø	2
11	510-0139	ROTISSERIE GEAR ASSEMBLY	1
12	510-0511	WARMING RACK BRACKET ASSEMBLY - LEFT SIDE	1
13	510-0519	WARMING RACK BRACKET ASSEMBLY- RIGHT SIDE	1
14	510-0673	ROTISSERIE PANEL ASSY	1
15	510-0955	BACK HOOD AND RIM - WELDED PARTS	1

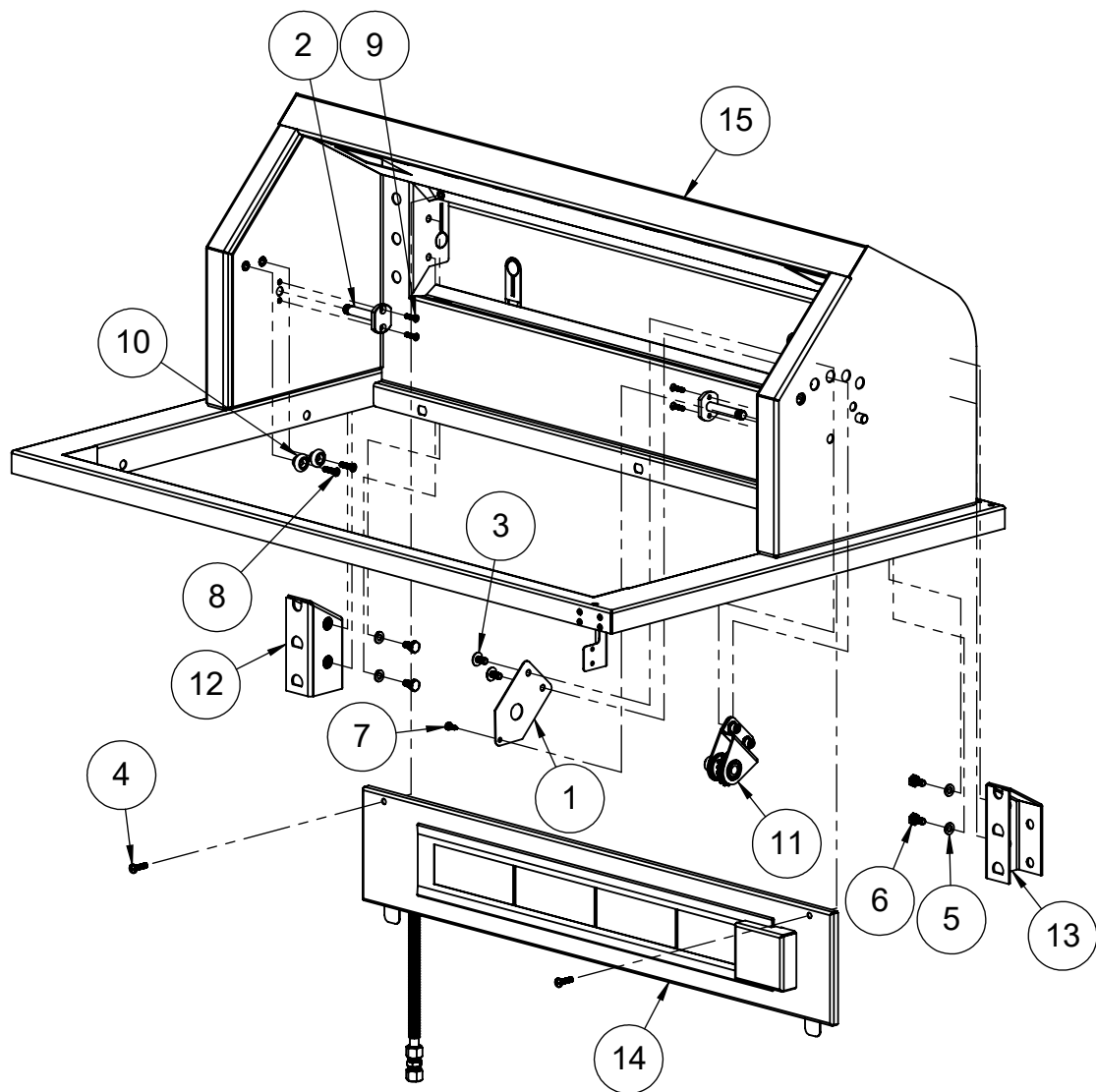

ITEM	PART NO.	DESCRIPTION	QTY
1	100-1226	ROTISSERIE ELECTRODE BRACKET	1
2	100-1882	ROTISSERIE ELECTRODE COVER	1
3	200-0111	SCREW 8-18 X 1/2 - SELF TAP - 410 SS	3
4	210-0240	ELECTRODE - DUAL TIP "L" SHAPE- ROTISSERIE	1
5	510-0469	ROTISSERIE PIPING SUBASSEMBLY	1
6	510-0674	ROTISSERIE PANEL - WELDED PARTS	1

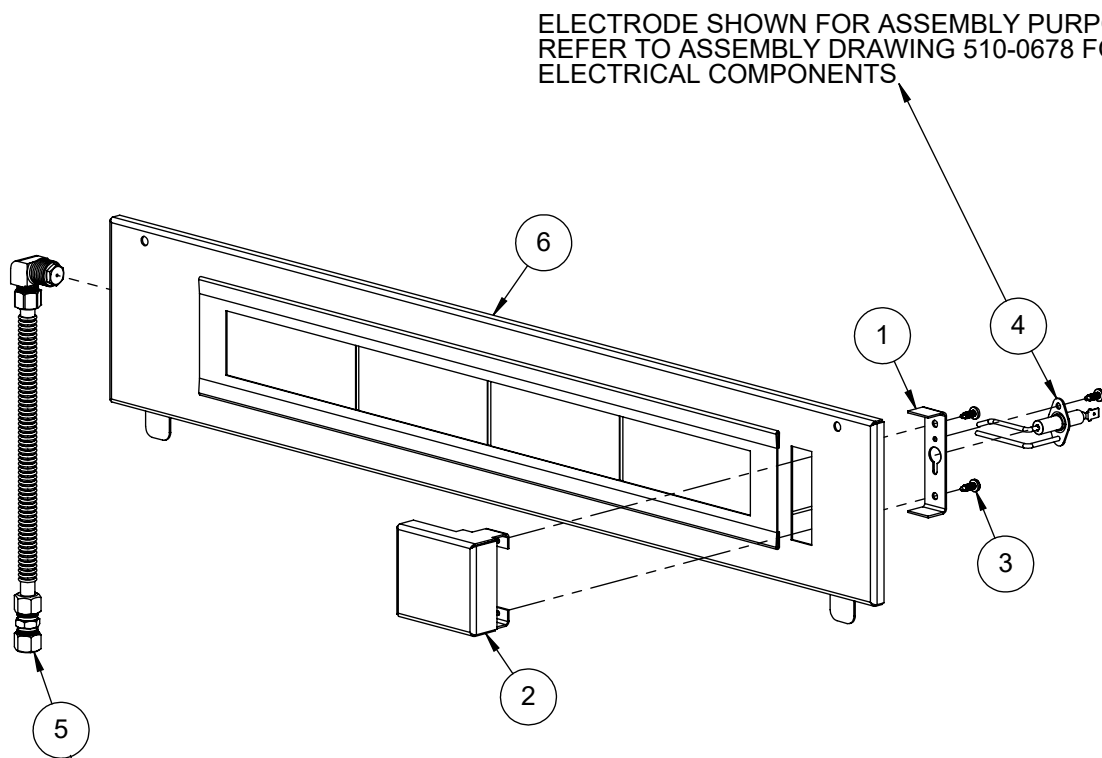

ELECTRODE SHOWN FOR ASSEMBLY PURPOSE ONLY  
REFER TO ASSEMBLY DRAWING 510-0678 FOR ALL  
ELECTRICAL COMPONENTS

THESE PARTS ARE SHOWN FOR ASSEMBLY PURPOSES ONLY  
REFER TO ASSEMBLY DRAWING 510-1038 FOR COMPLETE  
PARTS BREAKDOWN AND ORIFICE INFORMATION

ITEM	PART NUMBER	DESCRIPTION	QTY
1	200-0087	WASHER, 1/4" - SPRING LOCK - SS	4
2	200-0219	SCREW 1/4-20 UNC X 5/8 LONG - HEX HD - SS	4
3	200-0361	SCREW 8-32 X 5/8" - FLAT HEAD 82° - PHILLIPS	4
4	210-0571	3-1/8 DIA THERMOMETER	1
5	290-0400	HANDLE END CAP	2
6	290-0440	BBQ HANDLE BAR	1
7	290-0465	BUMPER 600°F 1/2" DIA x 5/32" HEAD	2
8	510-0924	SPIRAL TORSION SPRING LT	1
9	510-0925	SPIRAL TORSION SPRING RT	1
10	510-1211	FRONT HOOD WELDED PARTS	1

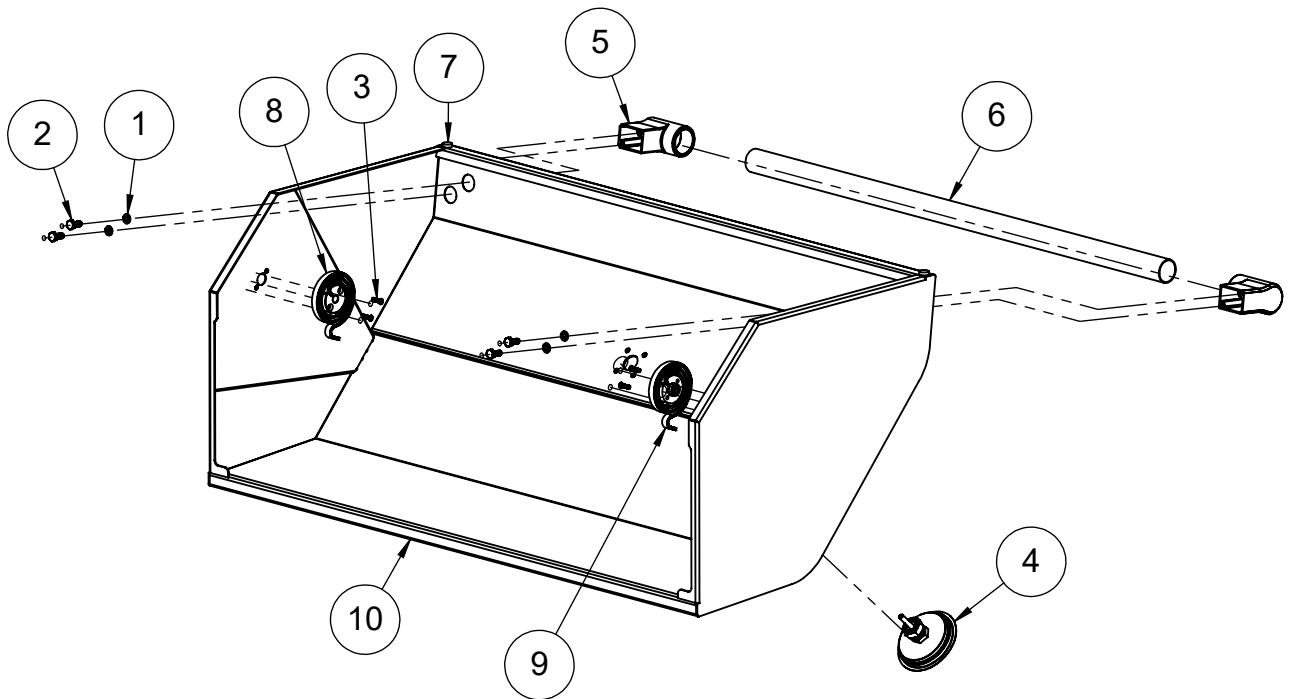

ITEM	PART NO.	DESCRIPTION	QTY
1	100-2220	BRIQUETTE TRAY BASE	1
2	100-2221	BRIQUETTE LOCK BAR	2
3	200-0312	SCREW 8-32 x 3/4"- PAN HEAD - PHILLIPS - THREAD CUTTER TYPE F	6
4	265-0005	BRIQUETTE - ALFRESCO CUSTOM	18

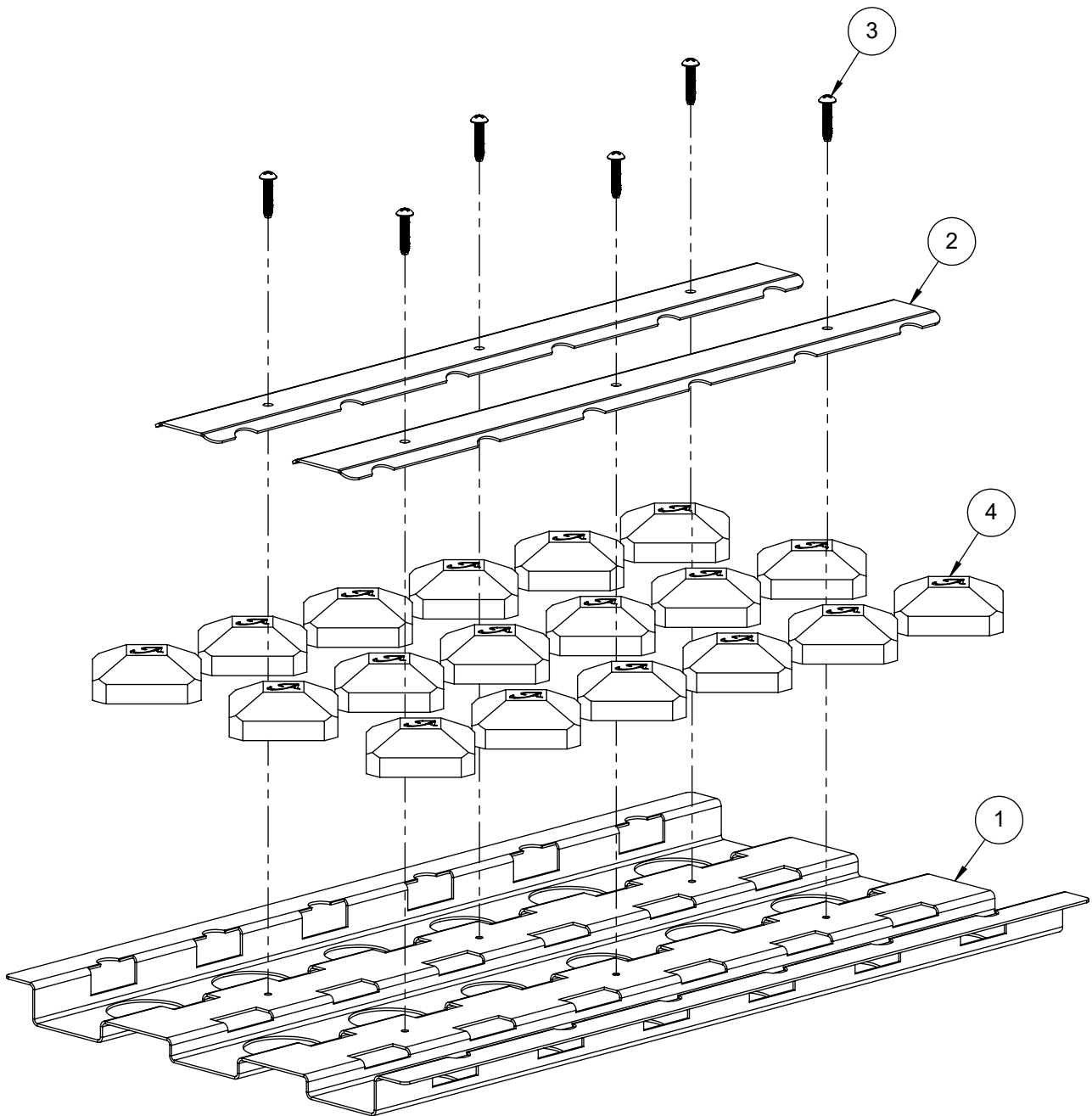

ITEM	PART NO.	DESCRIPTION	QTY
1	100-0917	SEAR ZONE™ GAS LINE (8"L x 3/8" Ø - SS. FLEX TUBE)	1
2	100-0917	ROTISSERIE GAS LINE EXTENSION - 3/8"Ø X 8" - SS	1
3	100-1067	SMOKER & SZ™ ORIFICE BRACKET	1
4	100-1949	ROTISSERIE GAS LINE (36"L x 3/8" Ø - SS. FLEX TUBE)	1
5	100-2217	SMOKER GAS LINE	1
6	200-0274	ELBOW 90°- CAST IRON - 1/2" FPT x 1/2" MPT	1
7	220-0151	COUPLING 3/8" x 3/8" - COMPRESSION - BRASS	1
8	220-0273	ELBOW 90° - 1/8" FPT x 3/16" COMP	1
9	220-0275	NIPPLE - 1/2" MPT X 3/8" OD FL	1
10	220-0276	ELBOW 3/8" MPT x 1/8" FPT x 3/8" COMP	1
11	220-0277	NIPPLE 1/8"MPT x 1/16"MPT	1
12	220-0280	REGULATOR GAS - MAXITROL RV48CL440002	1
13	220-0293	ELBOW 3/8-27 UNS x 3/8" COMP	1
14	220-0416	GAS MANIFOLD	1
15	290-0041	GAS VALVE - STRAIGHT - WITHOUT ORIFICES	2
16	290-0066	GAS VALVE - ANGLED - ORIFICE: INT= 0.95 mm / EXT=NONE	1
17	290-0433	KNOB - BBQ VALVE - ASSEMBLY	4
18	290-0434	ALFRESCO -ROTISSERIE / SEAR ZONE™ KNOB	1
19	SEE NOTE	GAS VALVE - ANGLED WITH ORIFICE >>> SEE NOTE	3
20	SEE NOTE	ORIFICE - IR ROTISSERIE UNIT (SEE NOTE FOR SIZING)	1
21	SEE NOTE	ORIFICE - SEAR ZONE™ >>> SEE NOTE	1

NOTE: ORIFICE OR VALVE ASSEMBLY TO CHANGE ACCORDING TO FUEL SUPPLY: NATURAL GAS OR LIQUID PROPANE

ITEM	NG GAS	LP GAS
	PART #	PART #
19	290-0310	290-0310
20	220-0285	220-0285
21	220-0289	220-0289

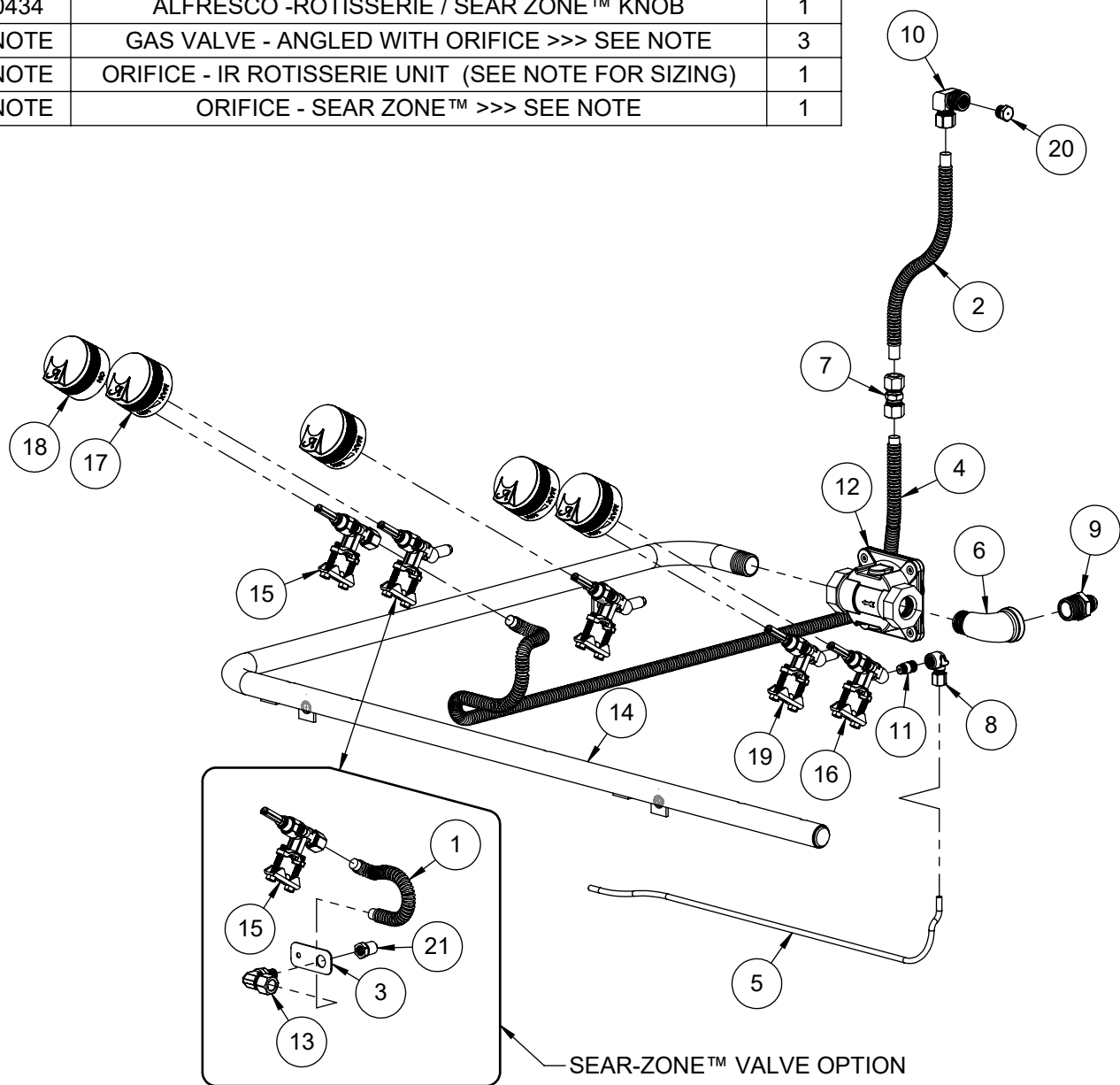

ITEM	PART NUMBER	DESCRIPTION	QTY
1	100-2633	SMOKER BURNER MOUNTING BRACKET	1
2	200-0111	SCREW 8-18 X 1/2 - SELF TAP - 410 SS	3
3	210-0189	ELECTRODE - "L" SHAPED - MAIN BURNER	1
4	220-0273	ELBOW 90° - 1/8" FPT x 3/16" COMP	1
5	510-0504	SMOKER BURNER ASSEMBLY	1
6	SEE NOTE	ORIFICE - SMOKER UNIT >>> SEE NOTE	1

**NOTE:** ORIFICE OR VALVE ASSEMBLY TO CHANGE ACCORDING TO FUEL SUPPLY: NATURAL GAS OR LIQUID PROPANE

ITEM	NG GAS	LP GAS
	PART #	PART #
6	220-0468	220-03

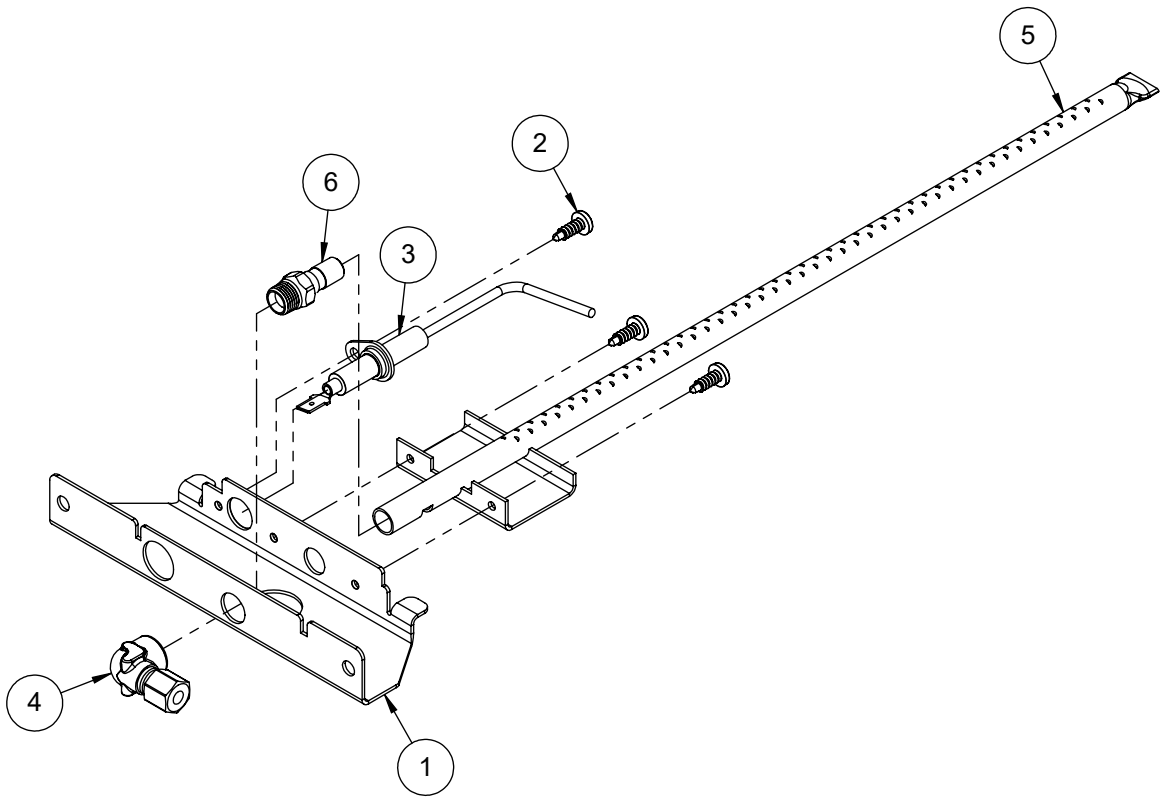

ITEM	PART NO.	DESCRIPTION	QTY
1	210-0189	ELECTRODE - "L" SHAPED - U-BURNER / SMOKER	3
2	210-0192	ELECTRODE - DUAL TIP - SEARZONE™	1
3	210-0240	ELECTRODE - DUAL TIP "L" SHAPE- ROTISSERIE	1
4	210-0466	IGNITER MODULE (6 POINTS)	1
5	210-0509	LAMP ASSEMBLY (32" WIRE LENGTH)	1
6	210-0510	LAMP ASSEMBLY ( 56" WIRE LENGTH)	1
7	210-0543	IGNITER WIRE KIT	1
8	210-0626	PERIMETER LIGHT SWITCH	1
9	510-0514	ROTISSERIE MOTOR BOX ASSEMBLY	1

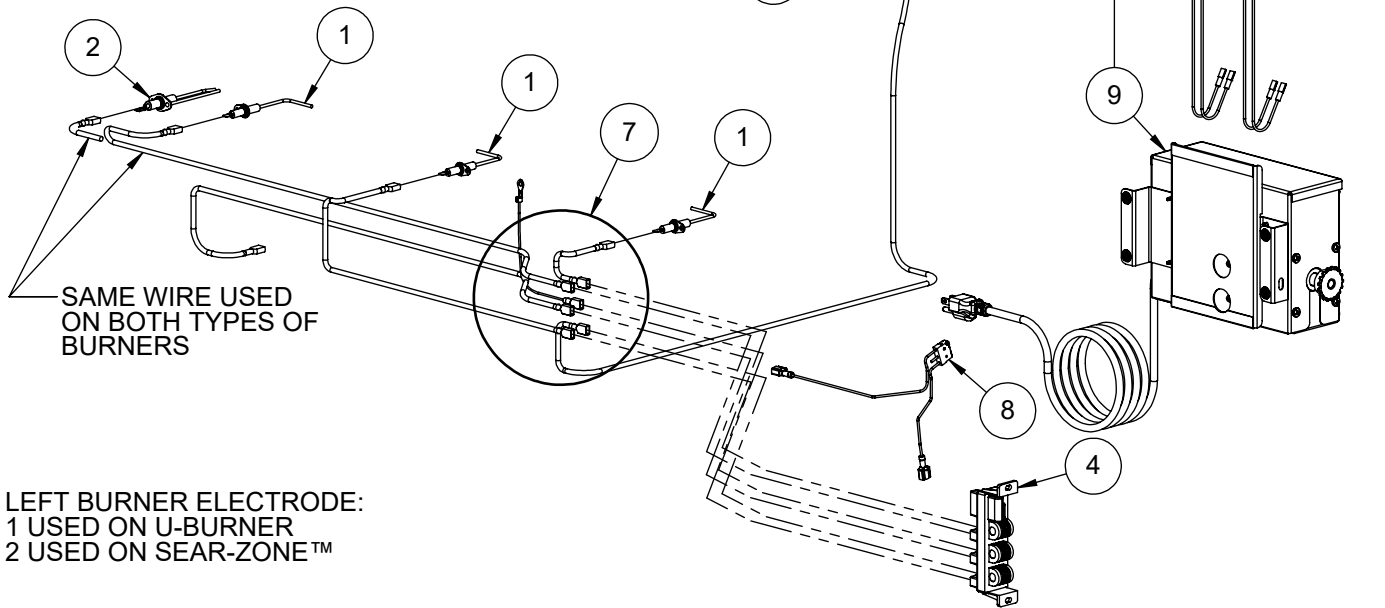
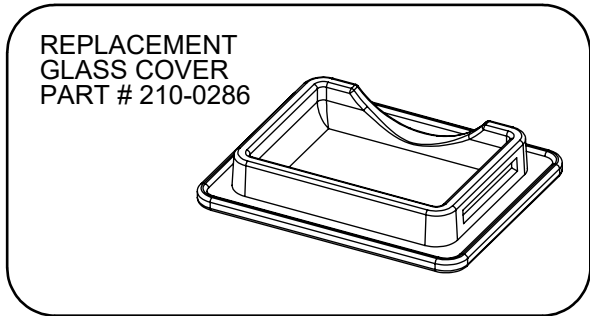
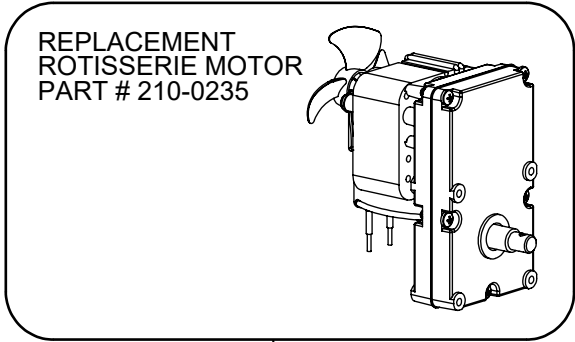
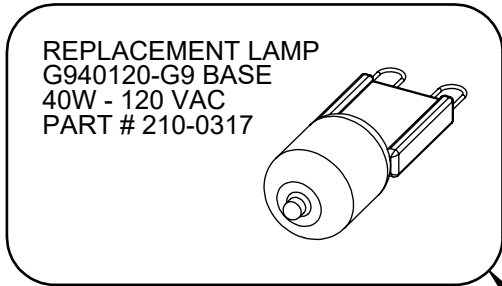

CONNECTIONS: NEUTRAL TO TRANSFORMER,  
POWER TO TRANSFORMER, IGNITER, LIGHTS  
& ROTISSERIE. FRONT LEFT.

CONNECTIONS IN  
MOTOR BOX AT  
REAR RIGHT.

CONNECTIONS: NEUTRAL & POWER,  
PERIMETER LIGHT SWITCH NEUTRAL & POWER,  
AND POWER TO TRANSFORMER. FRONT RIGHT.

**WIRING HARNESS PART NUMBER 210-0606**

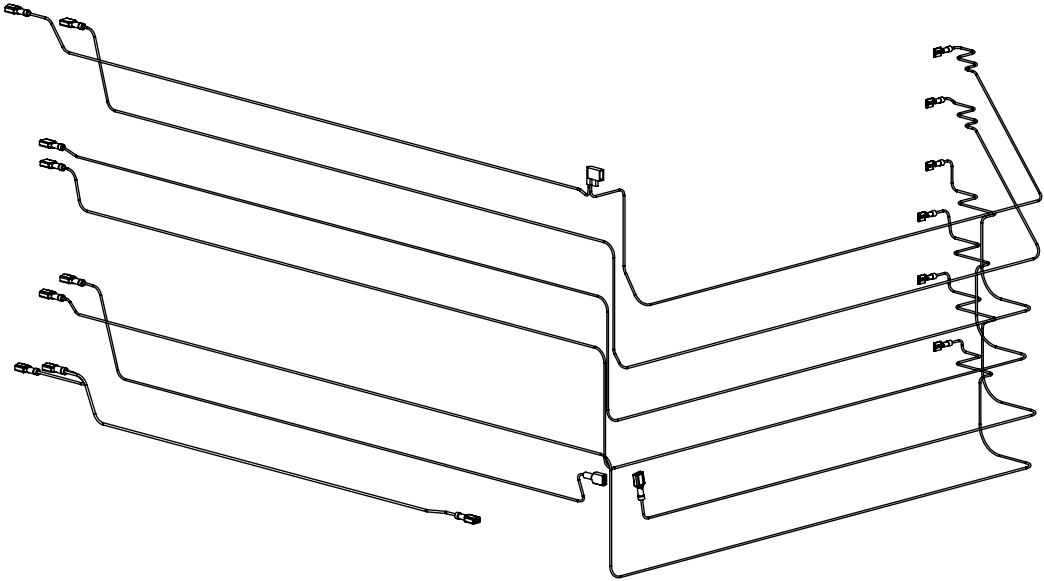

**EXPLODED VIEW OF WIRING HARNESS**  
**NOTE: INDIVIDUAL WIRES ARE NOT SOLD SEPARATELY**

# *Alfresco*<sup>™</sup>

*Open Air Culinary Systems*

***ALXE-36 PARTS MANUAL  
ALFRESCO<sup>™</sup> GOURMET GRILLS  
ALL RIGHTS RESERVED 02/2018***