

Artisan

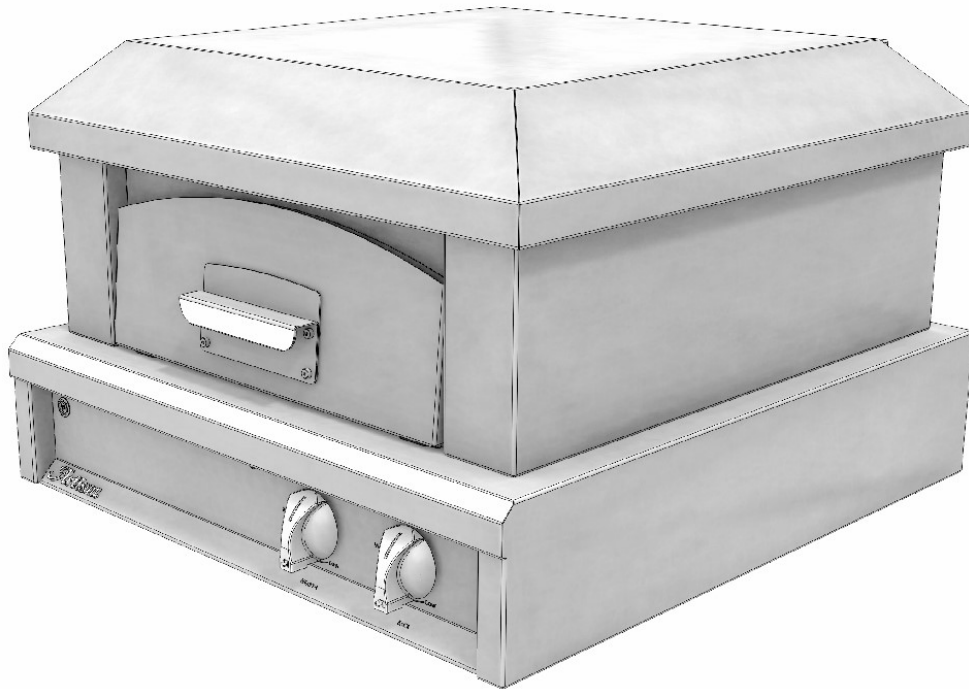

ARTP-PZA

COUNTER MOUNT PIZZA OVEN UNIT

BILL OF MATERIAL

| NO. | PART # | DESCRIPTION | QTY |
|-----|----------|--|-----|
| 1 | 100-3127 | ARTP-PZA STONES CENTER SUPPORT | 1 |
| 2 | 100-3137 | ARTP-PZA OVEN CAVITY INTERIOR TOP | 1 |
| 3 | 100-3140 | ARTP-PZA EXTERIOR TOP | 1 |
| 4 | 200-0199 | SCREW 6-32 x 1/4 - PAN HEAD CROSS - SS | 2 |
| 5 | 290-0366 | BOTTOM PIZZA STONE | 2 |
| 6 | 290-0367 | TOP REFRACTIVE STONE | 1 |
| 7 | 510-1260 | BASE - MAIN ASSEMBLY | 1 |
| 8 | 510-1266 | OVEN EXHAUST | 1 |
| 9 | 510-1267 | OVEN CAVITY | 1 |
| 10 | 510-1271 | ARTP-PZA FRONT COVER ASSEMBLY | 1 |

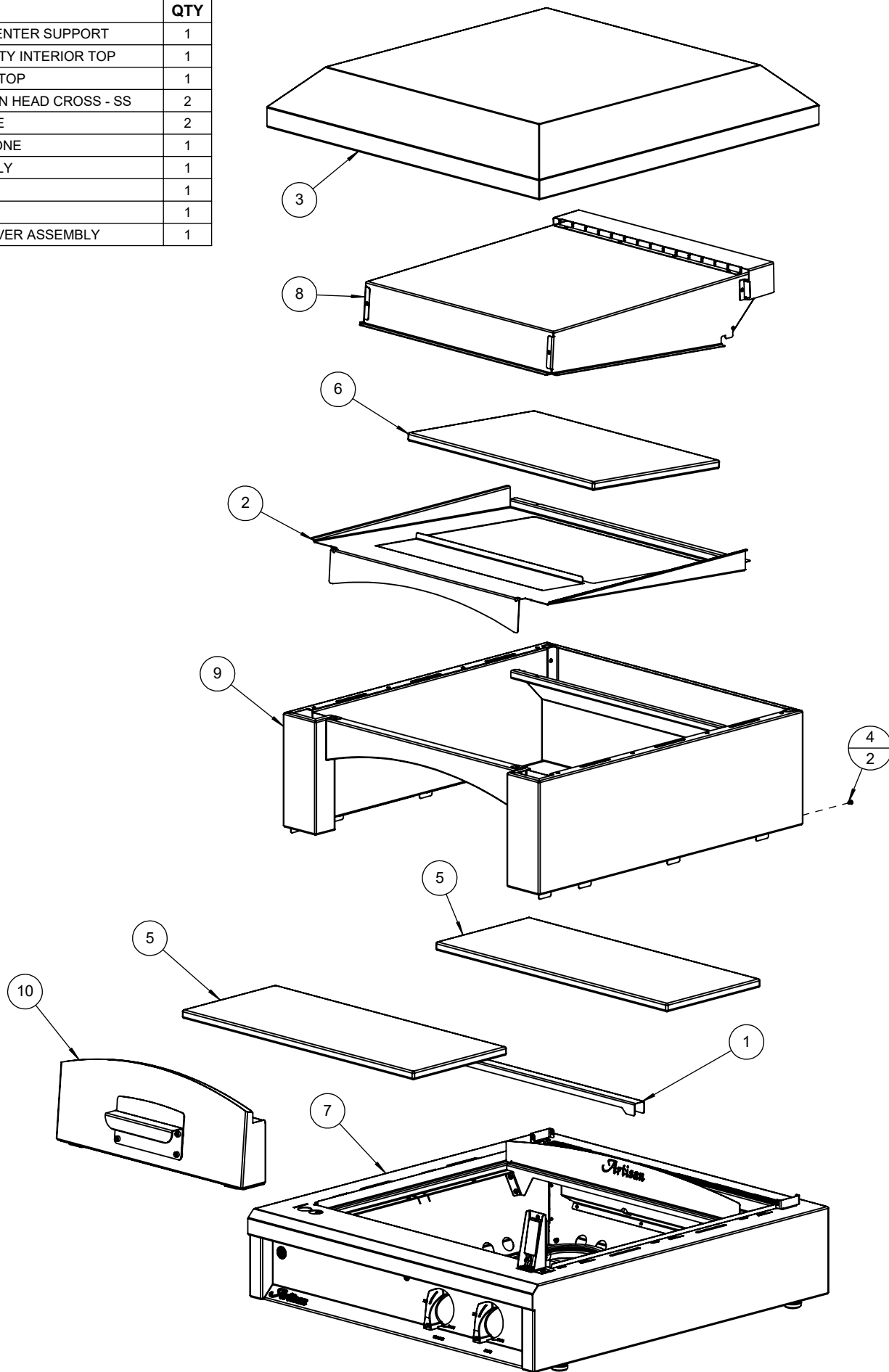

BILL OF MATERIAL

| NO. | PART # | DESCRIPTION | QTY |
|-----|----------|---|-----|
| 1 | 100-3116 | ARTP-PZA LED LIGHT BRACKET | 1 |
| 2 | 100-3117 | ARTP-PZA LED REFLECTOR | 1 |
| 3 | 100-3119 | ARTP-PZA J-BOX COVER | 1 |
| 4 | 100-3122 | ARTP-PZA STONE BACK SUPPORT / EDGE | 1 |
| 5 | 100-3125 | ARTP-PZA BOTTOM HEAT SHIELD | 1 |
| 6 | 100-3126 | ARTP-PZA OVEN LIGHT BRACKET | 1 |
| 7 | 200-0082 | SCREW 10-32 X 1/4 - PAN HEAD - PHILIPS | 10 |
| 8 | 200-0111 | SCREW 8-18 X 1/2 - SELF TAP - 410 SS | 14 |
| 9 | 200-0199 | SCREW 6-32 x 1/4 - PAN HEAD CROSS - SS | 1 |
| 10 | 200-0267 | SCREW 10-32 X 1/2 - PAN HEAD - PHILLIPS | 6 |
| 11 | 210-0662 | BLUE LED LIGHT - Ø 8 mm - WITH PINS | 2 |
| 12 | 290-0362 | LEVEL MOUNT 1/4-20 x 2 1/4 | 4 |
| 13 | 510-1261 | BASE - OUTSIDE RIVETED PARTS | 1 |
| 14 | 510-1262 | BASE - INSIDE FRAME | 1 |
| 15 | 510-1263 | CONTROL PANEL | 1 |
| 16 | 510-1264 | MANIFOLD ASSEMBLY | 1 |
| 17 | 510-1269 | ELECTRICAL COMPONENTS | 1 |

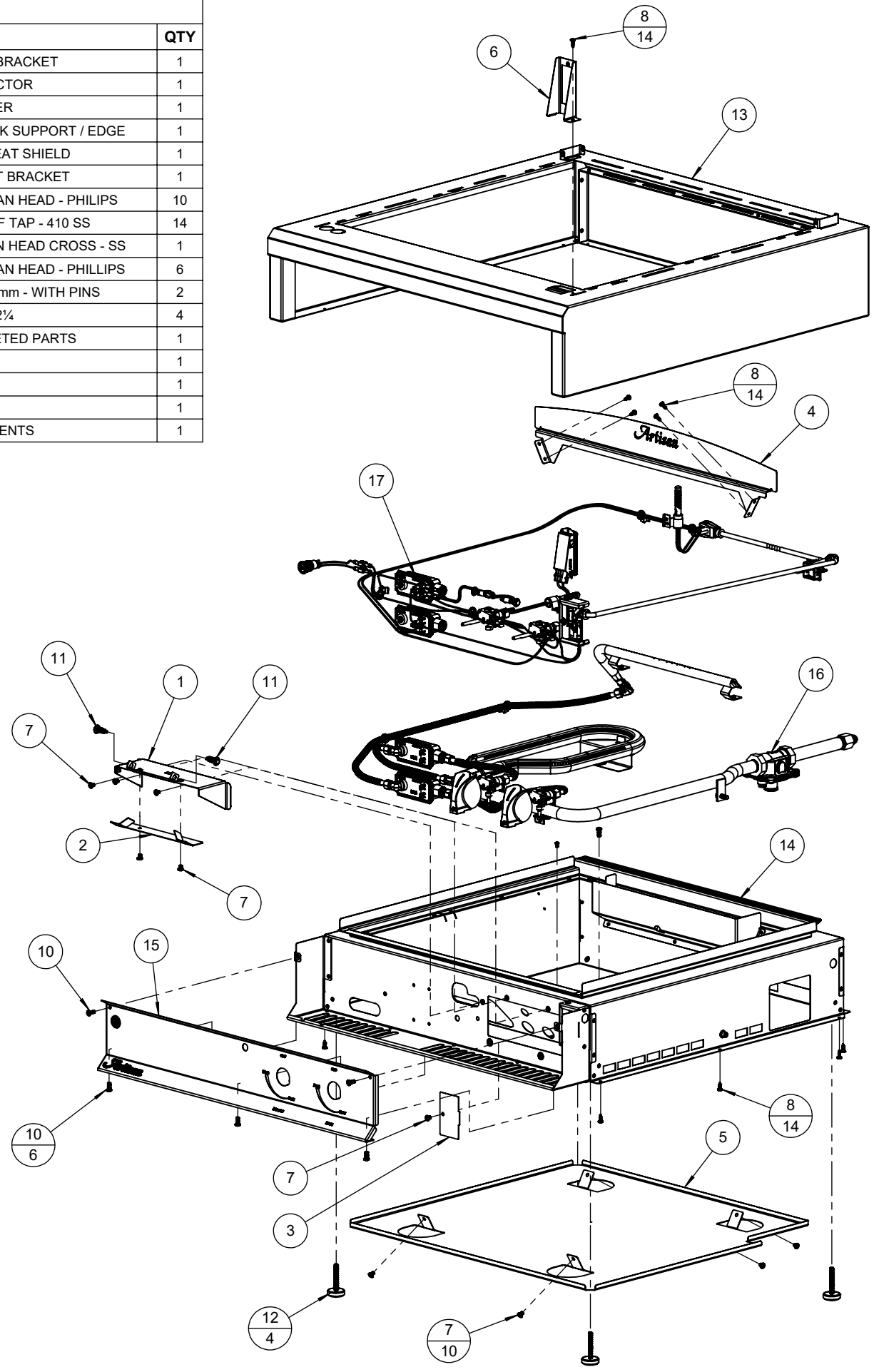

BILL OF MATERIAL

| NO. | PART # | DESCRIPTION | QTY |
|-----|----------|---|-----|
| 1 | 100-3113 | ARTP-PZA FRONT PANEL | 1 |
| 2 | 290-0356 | ARTISAN LOGO | 1 |
| 3 | 200-0093 | WASHER - PUSH LOCK 1/8" ID X 3/8" OD (LOGO) | 2 |
| 4 | 210-0584 | SWITCH - LIGHT - LATCHING [ON/OFF] | 1 |
| 5 | 210-0581 | WASHER - LOCK - Ø 19 mm - INTERNAL TEETH | 1 |
| 6 | 210-0582 | NUT - Ø 19 mm X 1 | 1 |

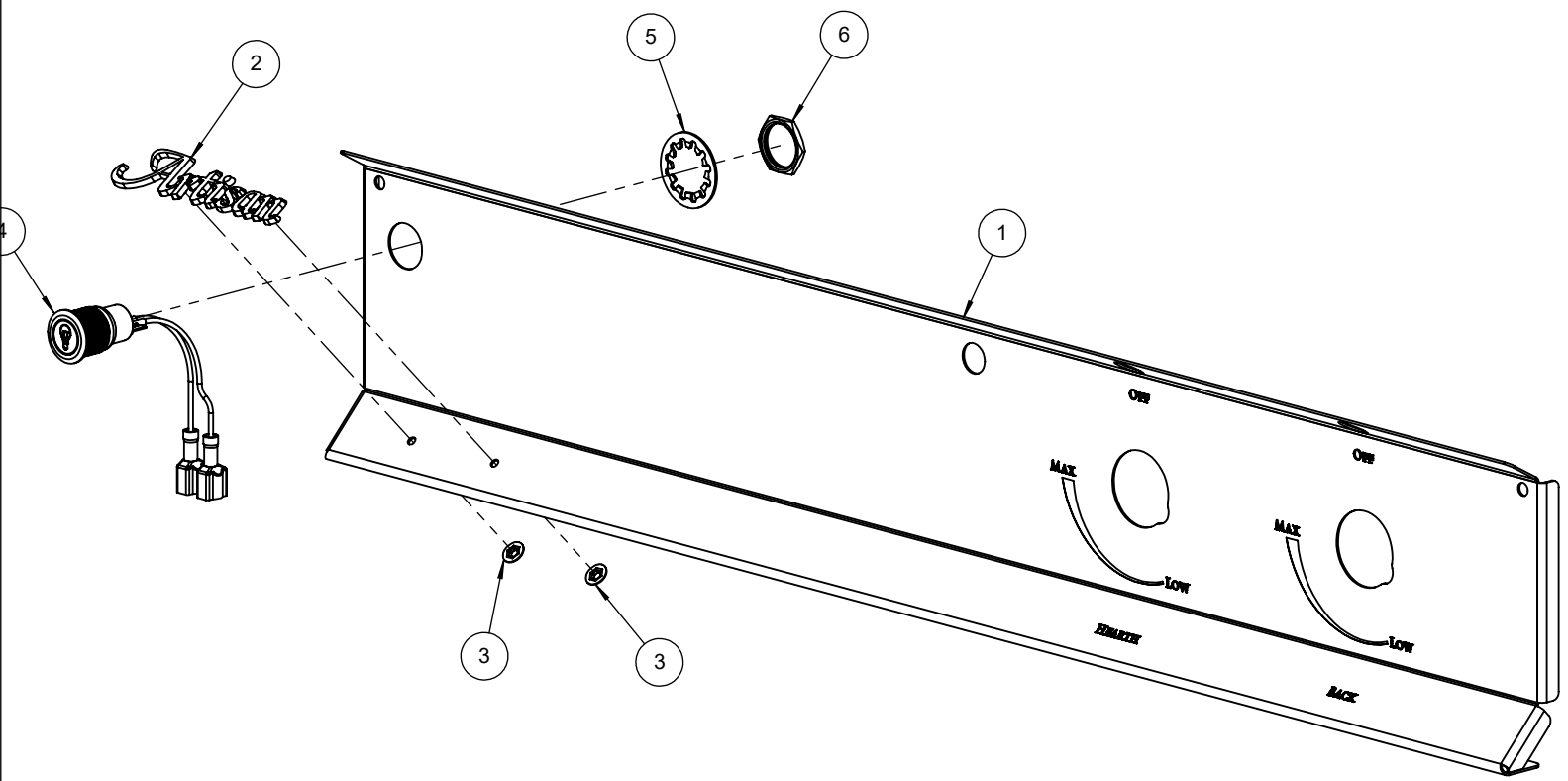

BILL OF MATERIAL

| NO. | PART # | DESCRIPTION | QTY |
|-----|----------|--|-----|
| 1 | 200-0087 | WASHER, 1/4" - SPRING LOCK - SS | 3 |
| 2 | 200-0206 | 8-32 KEP NUT 18-8 STAINLESS | 4 |
| 3 | 200-0242 | BOLT 1/4-20 UNC x 3/4 - HEX HEAD - SS | 3 |
| 4 | 210-0258 | CABLE TIE - T&B L-5-50PM-9 | 2 |
| 5 | 220-0280 | REGULATOR GAS - MAXITROL RV48CL440002 | 1 |
| 6 | 220-0403 | NIPPLE 3/8" OD FL x 1/2" FPT (FOR LP HOOK-UP) | 1 |
| 7 | 220-0458 | BRACKET - GAS VALVE SADDLE MOUNT | 2 |
| 8 | 220-0459 | SCREW M5 x 26 - POZI•COMB•HEX HEAD- 11.5 PT | 2 |
| 9 | 220-0474 | ELBOW 90° - Ø 5/16" COMPRESSION X 3/8-27 UNS-2B | 2 |
| 10 | 220-0474 | ELBOW 1/8-27 UNS x 5/16" COMP | 2 |
| 11 | 220-0477 | GAS VALVE - SINGLE PORT 5/16" Ø COMP W/ SWITCH | 2 |
| 12 | 220-0478 | GAS LINE - 5/16" Ø 8" L - SS - FLEX | 1 |
| 13 | 220-0478 | GAS LINE - 5/16" Ø 8" L - SS - FLEX | 1 |
| 14 | 220-0480 | GAS LINE - 5/16" Ø X 13" L - SS - FLEX | 1 |
| 15 | 220-0483 | SAFETY GAS VALVE | 2 |
| 16 | 220-0485 | REDUCER 9/16-24 UNEF x 5/16" COMPRESSION - BRASS | 2 |
| 17 | 220-0489 | GAS MANIFOLD - ARTP-PZA | 1 |
| 18 | 220-0491 | GAS LINE - 5/16" Ø 36" L - SS - FLEX | 1 |
| 19 | 280-0176 | PIPE - 1/2" NPT X 6" - SCH 40 BLACK | 1 |
| 20 | 290-0373 | BACK BURNER | 1 |
| 21 | 290-0496 | GAS KNOB WITH "A" LOGO | 2 |
| 22 | 290-0497 | BOTTOM BURNER- 1Ø - 17.5" X 5" - WITH BRACKET | 1 |
| 23 | SEE NOTE | ORIFICE - BOTTOM BURNER | 1 |
| 24 | SEE NOTE | ORIFICE - REAR BURNER | 1 |

| FUEL ▶ | NG | | LP | |
|--------|------|----------|------|----------|
| ITEM ▼ | SIZE | NUMBER | SIZE | NUMBER |
| 23 | 50 | 220-0397 | 57 | 220-0398 |
| 24 | 42 | 220-0492 | 55 | 220-0415 |

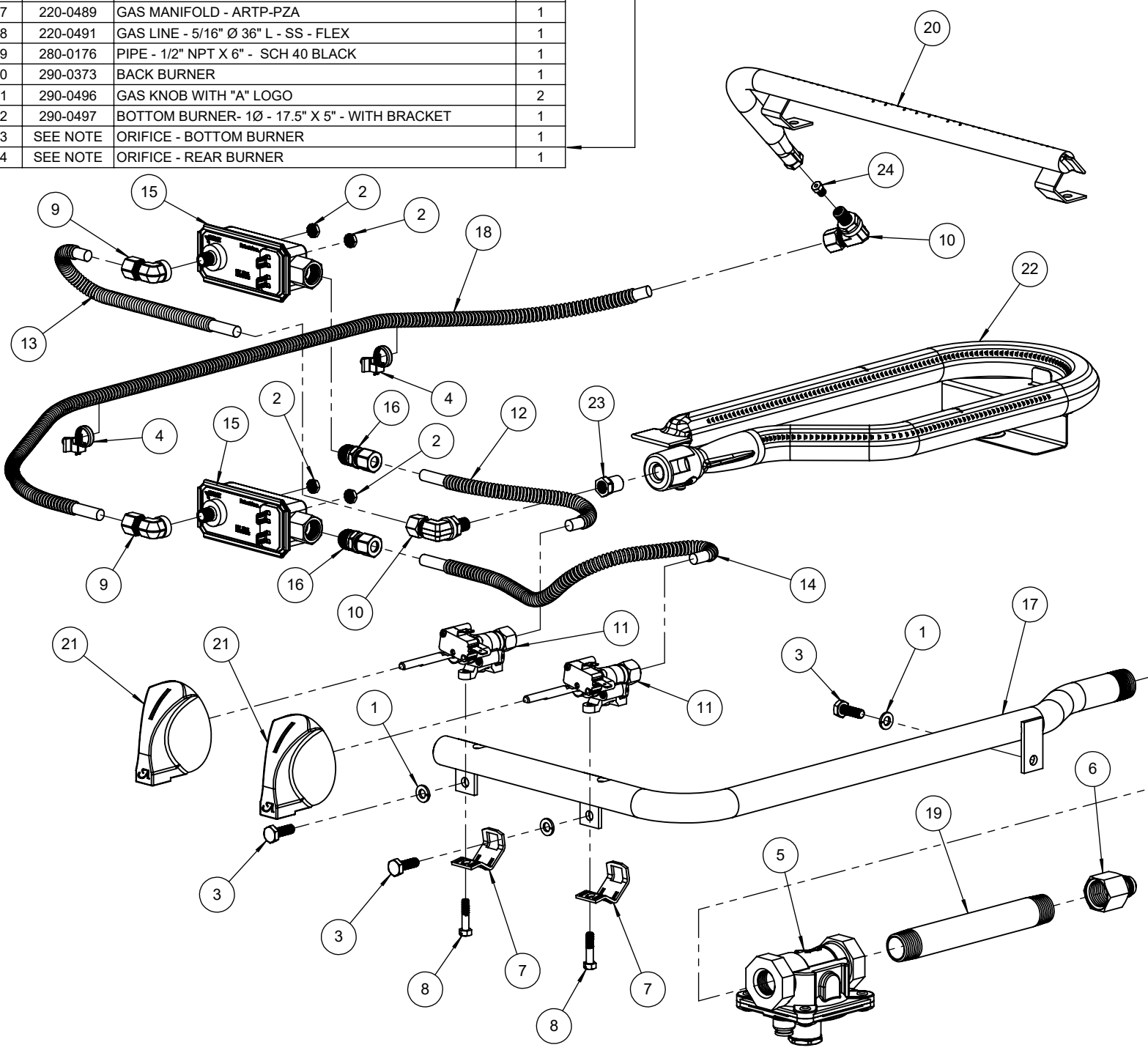

BILL OF MATERIAL

| NO. | PART # | DESCRIPTION | QTY |
|-----|----------|--|-----|
| 1 | 100-3118 | ARTP-PZA J-BOX | 1 |
| 2 | 200-0003 | GROMMET 3/8" Ø - MMC# 9600K33 | 1 |
| 3 | 200-0007 | GROMMET 1/4" Ø - SRB RUBBER | 1 |
| 4 | 200-0009 | HEYCO STRESS RELIEF BUSHING # 1200 SR 6N3-4 | 2 |
| 5 | 200-0320 | SCREW 8-32 x 3/8 - GROUNDING SCREW | 1 |
| 6 | 210-0258 | CABLE TIE - T&B L-5-50PM-9 | 4 |
| 7 | 210-0269 | CABLE STRAIN RELIEF - HEYCO 1843 | 1 |
| 8 | 210-0499 | NEMA 5-15 - 90° PLUG 18/3 EXTENSION CORD | 1 |
| 9 | 210-0584 | SWITCH - LIGHT - LATCHING [ON/OFF] | 1 |
| 10 | 210-0624 | LIGHT - BLUE LED - 8mm Ø - 110 VAC | 2 |
| 11 | 210-0675 | LIGHT HARNESS | 1 |
| 12 | 210-0680 | LAMP FIXTURE G9-B / 120 V - 25 W | 1 |
| 13 | 210-0681 | ARTP-PZA ELECTRICAL HARNESS | 1 |
| 14 | 210-0691 | BACK BURNER - HOT SURFACE IGNITER | 1 |
| 15 | 210-0692 | BOTTOM BURNER - HOT SURFACE IGNITER | 1 |
| 16 | 220-0477 | GAS VALVE - SINGLE PORT 5/16" Ø COMP W/ SWITCH | 2 |
| 17 | 220-0483 | SAFETY GAS VALVE | 2 |

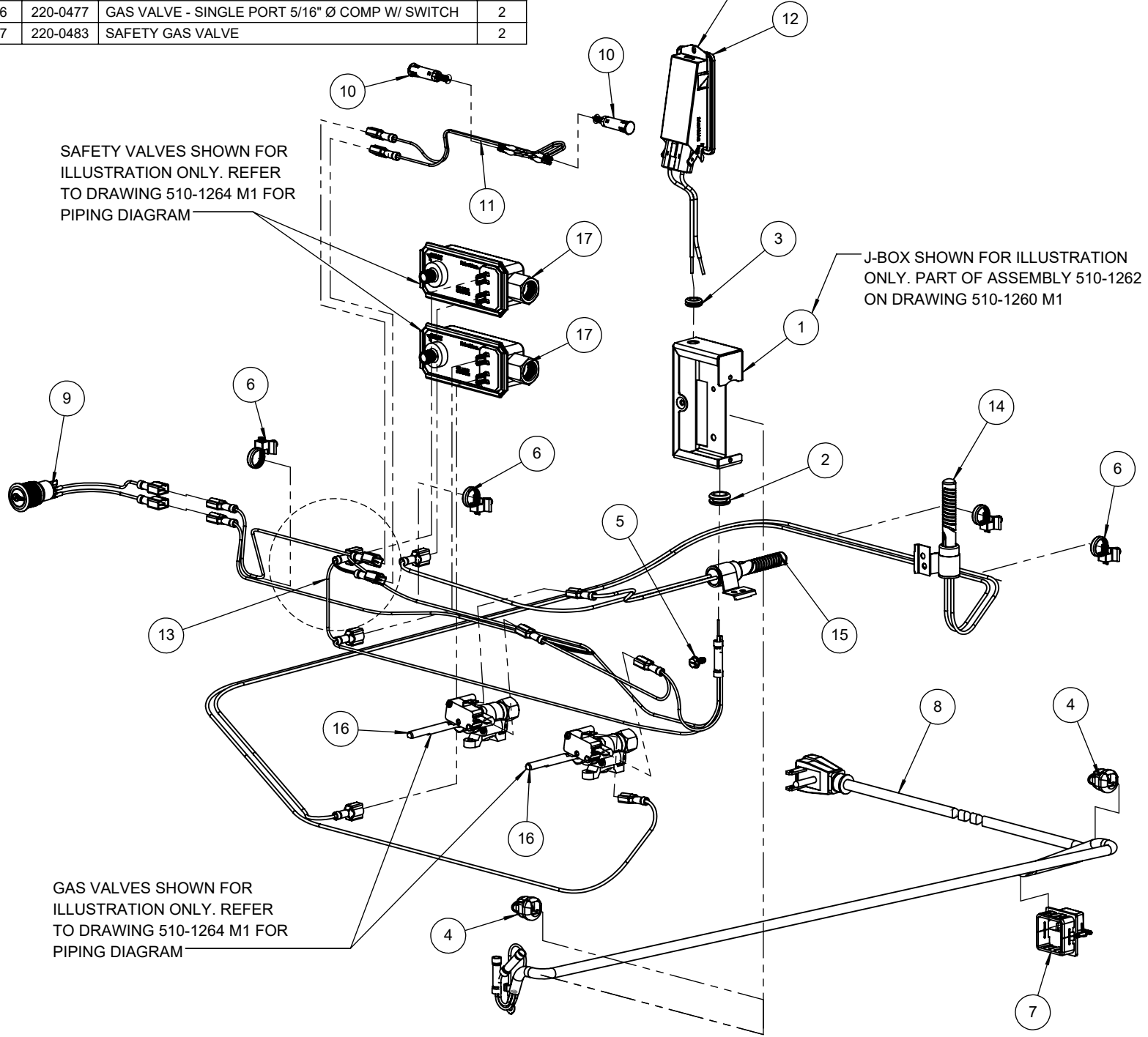
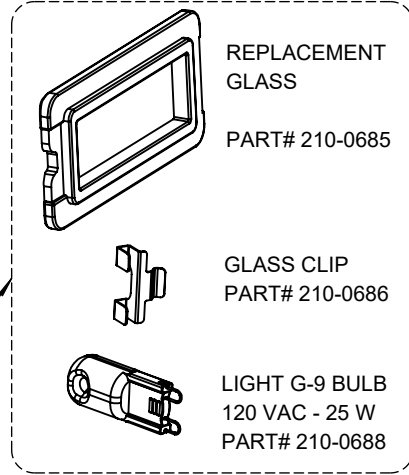

BILL OF MATERIAL

| NO. | PART # | DESCRIPTION | QTY |
|-----|----------|---|-----|
| 1 | 100-3148 | ARTP-PZA OVEN COVER HANDLE | 1 |
| 2 | 100-3149 | ARTP-PZA OVEN COVER HANDLE HEAT SHIELD | 1 |
| 3 | 200-0092 | 1/4 X 1/8 X 5/8 FLAT WASHER - SPACER | 4 |
| 4 | 200-0112 | SCREW 10-32 X 1/4 X 1/8 X 1/4- SHOULDER - 1/8 SOCKET - SS | 4 |
| 5 | 200-0194 | POP RIVET Ø.125 X .063- .125 RANGE | 2 |
| 6 | 290-0468 | BUMBER - OBROUND - 600 °F - BLACK SILICONE | 4 |
| 7 | 510-1268 | ARTP-PZA - OVEN FRONT COVER BACK ASSEMBLY | 1 |

