

This Owner's Manual is provided and hosted by [Appliance Factory Parts](#).



Monessen Hearth ODFORTG-36 Owner's Manual

[Shop genuine replacement parts for Monessen Hearth
ODFORTG-36](#)



[Find Your Monessen Hearth Fireplace Parts - Select From 701 Models](#)

----- Manual continues below -----

Owner's Manual

Care and Operation

INSTALLER: Leave this manual with party responsible for use and operation.

OWNER: Retain this manual for future reference.

Contact your dealer with questions regarding installation, operation or service.

NOTICE: DO NOT discard this manual!

FORTRESS outdoor
SERIES lifestyles
by hearth & home technologies®

Models: ODFORTG-36

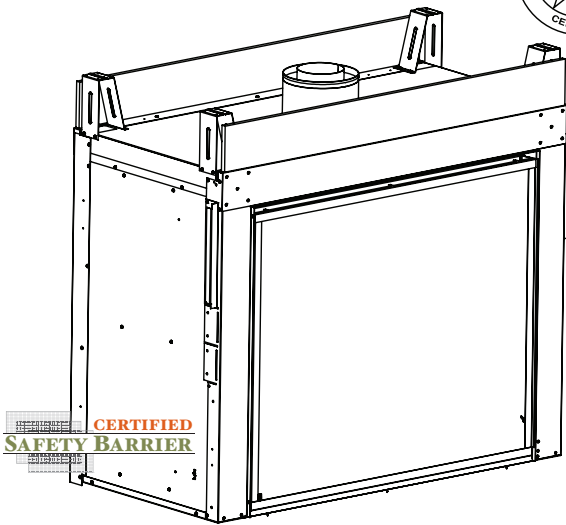

⚠ WARNING:
FIRE OR EXPLOSION HAZARD
Failure to follow safety warnings exactly could result in serious injury, death, or property damage.

- **DO NOT** store or use gasoline or other flammable vapors and liquids in the vicinity of this or any other appliance.
- **What to do if you smell gas**
 - **DO NOT** try to light any appliance.
 - **DO NOT** touch any electrical switch. **DO NOT** use any phone in your building.
 - Leave the building immediately.
 - Immediately call your gas supplier from a neighbor's phone. Follow the gas supplier's instructions.
 - If you cannot reach your gas supplier, call the fire department.
- Installation and service must be performed by a qualified installer, service agency, or the gas supplier.

This appliance may be installed as an OEM installation in manufactured home (USA only) or mobile home and must be installed in accordance with the manufacturer's instructions and the *Manufactured Home Construction and Safety Standard, Title 24 CFR, Part 3280* in the United States, or the *Standard for Installation in Mobile Homes, CAN/CSA Z240 MH Series*, in Canada.

This appliance is only for use with the type(s) of gas indicated on the rating plate. This appliance is not convertible for use with other gases, unless a certified kit is used.

In the Commonwealth of Massachusetts installation must be performed by a licensed plumber or gas fitter.

See appliance installation manual for additional Commonwealth of Massachusetts requirements.

⚠ DANGER



HOT GLASS WILL CAUSE BURNS.

DO NOT TOUCH GLASS UNTIL COOLED.

NEVER ALLOW CHILDREN TO TOUCH GLASS.

A barrier designed to reduce the risk of burns from the hot viewing glass is provided with this appliance and must be installed for the protection of children and other at-risk individuals.

1 Welcome

Read this manual before operating this appliance.
Please retain this Owner's Manual for future reference.

Read the Installation Manual before making any installation or finishing changes.

A. Congratulations

Congratulations on selecting a Outdoor Lifestyles gas fireplace, an elegant and clean alternative to wood burning fireplaces. The Outdoor Lifestyles gas fireplace you have selected is designed to provide the utmost in safety, reliability, and efficiency.

As the owner of a new fireplace, you'll want to read and carefully follow all of the instructions contained in this owner's manual. Pay special attention to all cautions and

warnings.

This owner's manual should be retained for future reference. We suggest that you keep it with your other important documents and product manuals.

The information contained in this owner's manual, unless noted otherwise, applies to all models and gas control systems.

Your new Outdoor Lifestyles gas fireplace will give you years of durable use and trouble-free enjoyment. Welcome to the Outdoor Lifestyles family of fireplace products!

Local Dealer Information

DEALER: Fill in your name, address, phone and email information here and appliance information below.

Dealer Name: _____
 Address: _____

 Phone: _____
 Email: _____

Appliance Information:

Brand: _____ Model Name: _____
 Serial Number: _____ Date Installed: _____

Listing Label Information/Location

The model information regarding your specific fireplace can be found on the rating plate usually located in the control area of the fireplace.

outdoor lifestyles
 by hearth & home technologies[®]
 Majestic, a brand of Hearth & Home Technologies
 7571 215th Street West, Lakeville, MN 55044

DESIGN CERTIFIED[®]

Not for use with solid fuel.
 (Ne doit pas être utilisé avec un combustible solide).

Type of Gas (Sorte De Gaz): This appliance must be installed in accordance with local codes, if any; if not, follow ANSI Z223.1 in the USA or CAN/CGA B149 installation codes. (Installer l'appareil selon les codes ou règlements locaux ou, en l'absence de tels règlements, selon les codes d'installation CAN/CGA-B149.)

NATURAL GAS

ANSI Z21XX-XXXX - CSA 2.XX-MXX - UL307B

Minimum Permissible Gas Supply for Purposes of Input Adjustment.

Approved Minimum (De Gaz) Acceptable	0.0 in w.c.	(Po. Col. d'eau)
Maximum Pressure (Pression)	0.0 in w.c.	(Po. Col. d'eau)
Maximum Manifold Pressure (Pression)	0.0 in w.c.	(Po. Col. d'eau)
Minimum Manifold Pressure (Pression)	0.0 in w.c.	(Po. Col. d'eau)

Total Electrical Requirements: 000Vac, 00Hz., less than 00 Amperes

MADE IN USA

ALTITUDE:	0-0000 FT.	0000-0000FT.	Model: (Modele):	XXXXXXXX
MAX. INPUT BTUH:	00,000	00,000	Serial (Serie):	XXXXXXXX
MIN. INPUT BTUH:	00,000	00,000		
ORIFICE SIZE:	#XXXXX	#XXXXX		

▲ Safety Alert Key:

- **DANGER!** Indicates a hazardous situation which, if not avoided will result in death or serious injury.
- **WARNING!** Indicates a hazardous situation which, if not avoided could result in death or serious injury.
- **CAUTION!** Indicates a hazardous situation which, if not avoided, could result in minor or moderate injury.
- **NOTICE:** Used to address practices not related to personal injury.

Table of Contents

1 Welcome

- A. Congratulations 2
- B. Limited Lifetime Warranty 4

2 Product Specific Information

- A. Appliance Certification 6
- B. Glass Specifications 6
- C. BTU Specifications 6

3 Important Safety and Operating Information

- A. Appliance Safety 7
- B. General Operating Parts 8
- C. Fuel Specifications 8
- D. Good Faith Wall Surface/TV Guidelines 9
- E. Before Lighting Appliance 10
- F. Lighting Instructions (IPI) 11
- G. Appliance Break-In 12
- H. Operation During A Power Outage - Intellifire™ Touch . . 12
 - Battery Pack Access 13
- I. Access to Control Module 14
- J. Detailed Component Operating Instructions - IntelliFire™ Touch 14-15

4 Maintenance and Service

- A. Maintenance: Frequency and Tasks 16
 - Remote Control/Venting 17
- ▶ B. Maintenance Tasks - Homeowner 16
 - Burner Ignition & Operation 19
 - Light Bulb Maintenance 19
 - Burner Flame 19
- C. Maintenance Tasks - Qualified Service Technician 18

5 Frequently Asked Questions and Troubleshooting

- A. Frequently Asked Questions - Appliance 20
- ▶ B. Frequently Asked Questions - IntelliFire™ Touch Controls (IFT-RC400) 21
- C. Troubleshooting 22

6 Reference Materials

- A. Accessories 24
- ▶ B. Service Parts 25
- C. IFT-RC400 User Guide 30
- D. Contact Information 33

➔ = Contains updated information.

B. Limited Lifetime Warranty

Outdoor Lifestyles by Hearth & Home Technologies™ Limited Lifetime Warranty

Hearth & Home Technologies (“HHT”) extends the following warranty for all Outdoor Lifestyles by HHT™ brand products (“Products”) that are purchased from an HHT authorized dealer.

WARRANTY COVERAGE:

HHT warrants to the original owner of the Product at the site of installation, and to any transferee taking ownership of the Product at the site of installation within one year following the date of original purchase, that the Product will be free from defects in materials and workmanship at the time of manufacture. After installation, if covered components manufactured by HHT are found to be defective in materials or workmanship during the applicable warranty period, HHT will, at its option, repair or replace the covered components. This warranty is subject to conditions, exclusions and limitations as described below.

WARRANTY PERIOD:

The warranty period begins on the earlier of: (i) the date of invoice for the Product; (ii) in the case of new home construction, the date of first occupancy of the residence or six months after the date of sale of the Product by an HHT authorized dealer, whichever occurs first; or (iii) the date 24 months following the date of Product shipment from HHT, regardless of the invoice or occupancy date.

WARRANTY CONDITIONS:

- The Limited Lifetime Warranty covers Products that are purchased through a HHT authorized dealer or distributor. A list of HHT authorized dealers is available on the HHT branded websites.
- This warranty is only valid while the Product remains at the site of original installation.
- Contact your installing dealer for warranty service. If the installing dealer is unable to provide necessary parts, contact the nearest HHT authorized dealer. Additional service fees may apply if you are seeking warranty service from a dealer other than the dealer from whom you originally purchased the Product.
- Check with your dealer in advance for any costs to you when arranging a warranty call. Travel and shipping charges for parts are not covered by this warranty.
- The Product body, metal firebox and heat exchanger carry the Limited Lifetime Warranty from the date of installation.
- The following components do not carry the Limited Lifetime Warranty but are warranted as follows:
 - One Year from Date of Installation:
 - Gas and Electrical Components or Gaskets
 - Nickel Plated Materials
 - Excludes tarnishing
 - Glass Breakage, Logs/Refractory/Glass Panels due to thermal breakage
 - Surface, hairline cracks, scratches and slight color changes are not covered
 - Venting, optional accessories, optional glass doors
 - Labor Associated with Warranty Service Work

WARRANTY EXCLUSIONS:

This warranty does not cover the following:

- Changes in surface finishes as a result of normal use. As a heating appliance, some changes in color of interior and exterior surface finishes may occur; this is not a flaw and not covered under warranty.
- Damage to printed, plated, or enameled surfaces caused by fingerprints, accidents, misuse, scratches, melted items, or other external sources and residues left on surfaces from the use of abrasive cleaners or polishes.
- Repair or replacement of parts that are subject to normal wear and tear during the warranty period. These parts include: paint, firebricks, grates, flame guides and the discoloration of glass.
- Minor expansion, contraction, or movement of certain parts causing noise. These conditions are normal and complaints related to this noise are not covered by this warranty.

Outdoor Lifestyles Warranty - 2108-975C – 6/5/2019 - 1

B. Limited Lifetime Warranty (*continued*)

- Damages resulting from: (1) failure to install, operate, or maintain the Product in accordance with the installation instructions, operating instructions, and listing agent identification label furnished with the Product; (2) failure to install the Product in accordance with local building codes; (3) shipping or improper handling; (4) improper operation, abuse, misuse, continued operation with damaged, corroded or failed components, accident, or incorrectly performed repairs; (5) inadequate ventilation, negative pressure or environmental conditions, including, without limitation: hail, snow, ice, fallen branches, flooding, water damage and fading of color; (6) use of fuels other than those specified in the operating instructions; (7) installation or use of components not supplied with the Product or any other components not expressly authorized and approved by HHT; (8) modification of the Product not expressly authorized and approved by HHT in writing; and/or (9) interruptions or fluctuations of electrical power supply to the Product.
- Non-HHT venting components, hearth components or other accessories used in conjunction with the Product.
- Any part of a pre-existing fireplace system in which an insert or a decorative gas appliance is installed.
- The Product's capability to heat the desired space. Information is provided to assist the consumer and the dealer in selecting the proper appliance for the application. Consideration must be given to the Product's location and configuration and environmental conditions.

This warranty is void if:

- The Product has been over-fired or operated in atmospheres contaminated by chlorine, fluorine, or other damaging chemicals. Over-firing can be identified by, but not limited to, warped plates or tubes, rust colored cast iron, bubbling, cracking and discoloration of steel or enamel finishes and cracking or spalling of refractory or cementitious materials.
- The Product is subjected to prolonged periods of dampness, condensation, ice or snow.
- There is any damage to the Product or other components due to water or weather damage which is the result of, but not limited to, improper chimney or venting installation.

LIMITATIONS OF LIABILITY:

Repair or replacement in accordance with the provisions of this warranty will be the owner's exclusive remedy for and will constitute HHT's sole obligation under this warranty, under any other warranty (express or implied), or in contract, tort or otherwise; provided, however, that if HHT is unable to provide repair or replacement in an expedient and cost effective manner, HHT may discharge all such obligations by refunding the purchase price of the Product. No employee, agent, dealer, or other person is authorized to give any warranty on behalf of HHT. TO THE EXTENT ALLOWED BY LAW, HHT MAKES NO OTHER WARRANTY, EXPRESS OR IMPLIED, INCLUDING ANY WARRANTY OF MERCHANTABILITY OR FITNESS FOR A PARTICULAR PURPOSE. HHT WILL NOT BE LIABLE FOR ANY CONSEQUENTIAL OR INCIDENTAL DAMAGES ARISING OUT OF DEFECTS IN OR USE OF THE PRODUCTS. Some states do not allow exclusions or limitation of incidental or consequential damages, so these limitations may not apply to you. This warranty gives you specific rights; you also may have other rights, which vary from state to state. The duration of any implied warranty is limited to the duration of the warranty period specified herein.

2 Product Specific Information

A. Appliance Certification

MODELS: ODFORTG-36
LABORATORY: CSA
TYPE: Vented Gas Fireplace Heater
STANDARD: CSA/ANSI Z21.88:19 • CSA 2.33:19



This product is listed to ANSI standards for “Vented Gas Fireplace Heaters” and applicable sections of “Gas Burning Heating Appliances for Manufactured Homes and Recreational Vehicles”, and “Gas Fired Appliances for Use at High Altitudes”.

NOTICE: *This installation must conform with local codes. In the absence of local codes you must comply with the National Fuel Gas Code, ANSI Z223.1-latest edition in the U.S.A. and the CAN/CGA B149 Installation Codes in Canada.*

NOT INTENDED FOR USE AS A PRIMARY HEAT SOURCE.

This appliance is tested and approved as either supplemental room heat or as a decorative appliance. It should not be factored as primary heat in residential heating calculations.

Installation and service of this appliance should be performed by qualified personnel. Hearth & Home Technologies recommends HHT Factory Trained or NFI certified professionals.

⚠ WARNING: This product and the fuels used to operate this product (liquid propane or natural gas), and the products of combustion of such fuels, can expose you to chemicals including benzene, which is known to the State of California to cause cancer and reproductive harm. For more information go to: www.P65Warnings.ca.gov.

B. Glass Specifications

This appliance is equipped with ceramic glass that is used on the inside glass door frames attached to the firebox. Replace glass only with ceramic glass. The outdoor glass in the black frame screwed to the Stainless Steel frame is tempered glass. Replace only with tempered glass.

Please contact your dealer for replacement glass.

C. BTU Specifications

Models <i>(U.S. or Canada)</i>		Maximum Input BTU/h	Minimum Input BTU/h	Orifice Size Middle (DMS)	Orifice Size Outer Burner (DMS)
ODFORTG-36 (NG)	<i>(0-4500FT)</i>	56,000	38,000	#31	#46
ODFORTG-36 (LP)	<i>(0-4500 FT)</i>	56,000	44,000	#50	#56

3 Important Safety and Operating Information

A. Appliance Safety

WARNING! DO NOT operate fireplace before reading and understanding operating instructions. Failure to operate fireplace according to operating instructions could cause fire or injury.



HOT GLASS WILL CAUSE BURNS.

DO NOT TOUCH GLASS UNTIL COOLED.

NEVER ALLOW CHILDREN TO TOUCH GLASS.

- Keep children away.
- CAREFULLY SUPERVISE children in same room as fireplace.
- Alert children and adults to hazards of high temperatures.

High temperatures may ignite clothing or other flammable materials.

- Clothing, furniture, draperies, and other flammable materials must not be placed on or near the appliance.

A barrier designed to reduce the risk of burns from the hot viewing glass is provided with this appliance and shall be installed for the protection of children and other at-risk individuals. DO NOT operate the appliance with the barrier removed. If the barrier becomes damaged, the barrier shall be replaced with the manufacturer's barrier for this appliance.

Contact your dealer or Hearth & Home Technologies if the barrier is not present or help is needed to properly install one.

Young children should be carefully supervised when they are in the same room as the appliance. Toddlers, young children and others may be susceptible to accidental contact burns.

- A physical barrier is recommended if there are at risk individuals in the house.
- To restrict access to a fireplace or stove, install an adjustable safety gate to keep toddlers, young children and other at risk individuals out of the room and away from hot surfaces.
- Install a switch lock or a wall/remote control with child protection lockout feature.
- Keep remote controls out of reach of children.
- Never leave children alone near a hot fireplace, whether operating or cooling down.

- Teach children to NEVER touch the fireplace.
- Consider not using the fireplace when children will be present.

Contact your dealer for more information, or visit: www.hpba.org/safety-information.

To prevent unintended operation when not using your fireplace for an extended period of time (summer months, vacations, trips, etc):

- Remove batteries from remote controls.
- Turn off wall controls.
- Unplug 6 volt adapter plug (IPI) and remove batteries from battery backup.

Clear Space

WARNING! DO NOT place combustible objects in front of the fireplace or block louvers. High temperatures could start a fire. See Figure 3.1.

Avoid placing candles and other heat-sensitive objects on mantel or hearth. Heat could damage these objects.

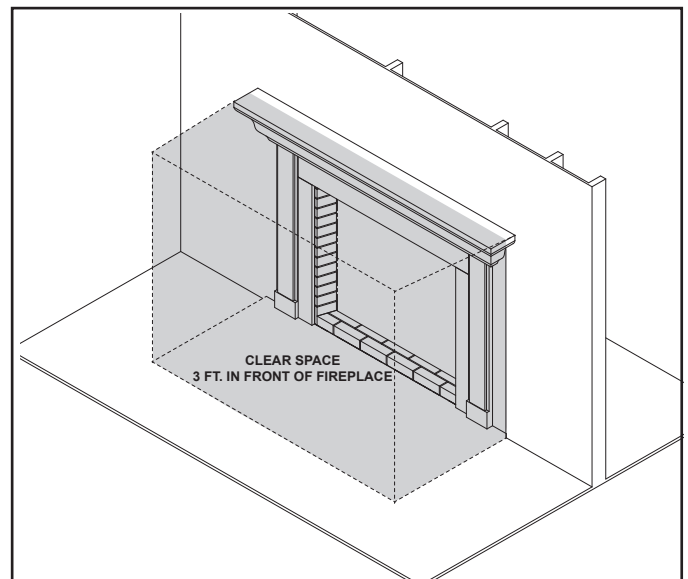

Figure 3.1 Clear Space Requirement - All Models

Over Firing

The appliance is considered to be over firing if the flames are contacting the top of the firebox. Call a qualified service technician to service the appliance

B. General Operating Parts

Figure 3.2 references the general operating parts of the appliance and the section of this manual in which they are discussed.

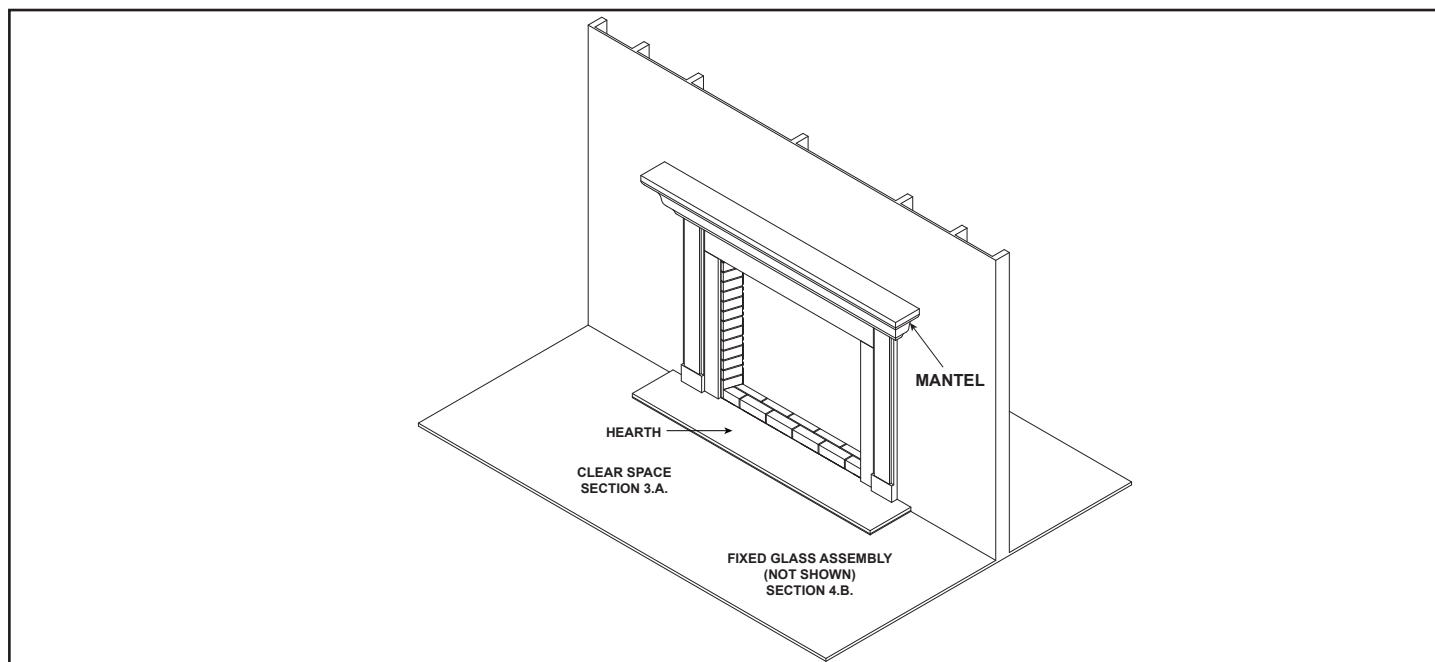

Figure 3.2 General Operating Parts

C. Fuel Specifications

WARNING! Risk of Fire or Explosion! Appliance must be set up for compatible gas type!

- This appliance is designed to operate on either natural gas or propane. Make sure the appliance is compatible with gas type selected for installation site.
- Conversions must be made by a qualified service technician using Hearth & Home Technologies specified and approved parts.

D. Good Faith Guidelines for TV Installation's above a Typical Gas Fireplace

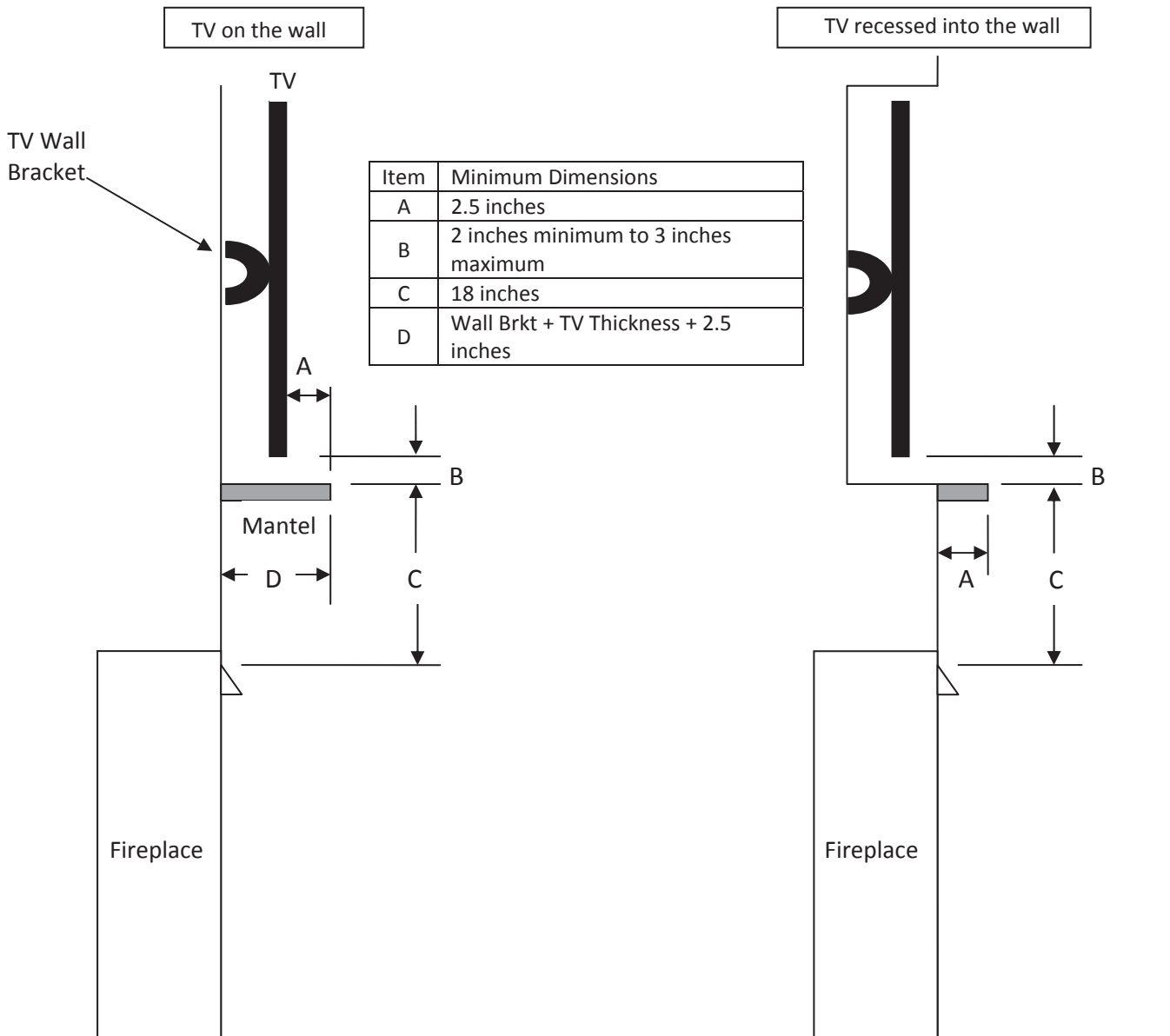

- Notes:
1. These are good faith recommended clearances only and not a guarantee of compliance with all TV manufacturers' maximum allowable operating temperatures.
 2. Since every home has unique air flow characteristics and maximum allowable operating temperatures can vary from manufacturer to manufacturer and from model to model, actual TV temperatures should be validated at the time of each installation. TVs should not be used in situations where the actual TV temperature exceeds the manufacturers' maximum allowable operating temperatures identified in the TV's technical specifications. Contact the TV's manufacturer directly if you cannot locate this information or have questions regarding the information.
 3. Mantel height and depth must conform to mantel requirements specified in the fireplace installation manual.
 4. "C" dimension taken from the top of the hood or fireplace opening.
 5. Suggestions on how to further reduce TV temperatures:
 - a. Increase "A" dimension.
 - b. Increase "C" dimension, however, increasing "B" dimension beyond maximum recommended typically results in higher temperatures.

Figure 3.3. Good Faith TV Guidelines

E. Before Lighting Appliance

Before operating this fireplace for the first time, **have a qualified service technician:**

- Verify all shipping materials have been removed from inside and/or underneath the firebox.
- Review proper placement of logs, ember material and/or other decorative materials.
- Check the wiring.
- Check the air shutter adjustment.
- Ensure that there are no gas leaks.
- Ensure that the glass is sealed and in the proper position and that the integral barrier is in place.

WARNING! Risk of Fire or Asphyxiation! DO NOT operate fireplace with fixed glass assembly removed.

F. Lighting Instructions (IPI)

The IPI system may be operated with four AAA cell batteries. When using batteries, unplug the transformer. To prolong battery life, remove them when using the transformer.

FOR YOUR SAFETY READ BEFORE LIGHTING



WARNING: If you do not follow these instructions exactly, a fire or explosion may result causing property damage, personal injury or loss of life.

- This appliance is equipped with an intermittent pilot ignition (IPI) device which automatically lights the burner. **DO NOT** try to light the burner by hand.
 - BEFORE LIGHTING**, smell all around the appliance area for gas. Be sure to smell next to the floor because some gas is heavier than air and will settle on the floor.
- WHAT TO DO IF YOU SMELL GAS**
- DO NOT** try to light any appliance.
 - DO NOT** touch any electric switch; do not use any phone in your building.
 - Immediately call your gas supplier from a neighbor's phone. Follow the gas supplier's instructions.
 - If you cannot reach your gas supplier, call the fire department.
- Use only your hand to push in or turn the gas control knob. Never use tools. If the knob will not push in or turn by hand, **DO NOT** try to repair it, call a qualified service technician. Force or attempted repair may result in a fire or explosion.
 - DO NOT** use this appliance if any part has been under water. Immediately call a qualified service technician to inspect the appliance and to replace any part of the control system and any gas control which has been under water.

LIGHTING INSTRUCTIONS (IPI)

- This appliance is equipped with an ignition device which automatically lights the burner. **DO NOT** try to light the burner by hand.
- Wait five (5) minutes to clear out any gas. Then smell for gas, including near the floor. If you smell gas, **STOP!** Follow "B" in the Safety Information located on the top of this label. If you do not smell gas, go to next step.
- To light the burner:
Equipped with wall switch: Turn ON/OFF switch to ON.
Equipped with remote or wall control: Press ON or FLAME button.
Equipped with thermostat: Set temperature to desired setting.
- If the appliance does not light after three tries, call your service technician or gas supplier.

**GAS
VALVE**

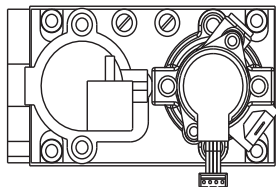

TO TURN OFF GAS TO APPLIANCE

- Equipped with wall switch: Turn ON/OFF switch to OFF.
Equipped with remote or wall control: Press OFF button.
Equipped with thermostat: Set temperature to lowest setting.
- Service technician should turn off electric power to the control when performing service.



DANGER



**HOT GLASS WILL CAUSE BURNS.
DO NOT TOUCH GLASS UNTIL COOLED.
NEVER ALLOW CHILDREN TO TOUCH GLASS.**

A barrier designed to reduce the risk of burns from the hot viewing glass is provided with this appliance and shall be installed for the protection of children and other at-risk individuals.

WARNING:

DO NOT CONNECT LINE VOLTAGE (110/120 VAC OR 220/240 VAC) TO THE CONTROL VALVE.

Improper installation, adjustment, alteration, service or maintenance can cause injury or property damage. Refer to the owner's information manual provided with this appliance. For assistance or additional information, consult a qualified installer, service agency or the gas supplier.

This appliance needs fresh air for safe operation and must be installed so there are provisions for adequate combustion and ventilation air.



WARNING: This product and the fuels used to operate this product (liquid propane or natural gas), and the products of combustion of such fuels, can expose you to chemicals including benzene, which is known to the State of California to cause cancer and reproductive harm. For more information go to: www.P65Warnings.ca.gov.

Keep burner and control compartment clean. See installation and operating instructions accompanying appliance.

CAUTION:

Hot while in operation. **DO NOT** touch. Keep children, clothing, furniture, gasoline and other liquids having flammable vapors away.

DO NOT operate the appliance with fixed glass assembly removed, cracked or broken. Replacement of the fixed glass assembly should be done by a licensed or qualified service person.

NOT FOR USE WITH SOLID FUEL

For use with natural gas and propane. A conversion kit, as supplied by the manufacturer, shall be used to convert this appliance to the alternate fuel.

Also Certified for Installation in a Bedroom or a Bedsitting Room.

This appliance must be installed in accordance with local codes, if any; if none, follow the *National Fuel Gas Code, ANSI Z223.1/NFPA 54*, or the *National Gas and Propane Installation code, CSA B149.1*.

**For additional information on operating your
Hearth & Home Technologies fireplace, please
refer to www.hearthnhome.com.**

G. Appliance Break-In

Initial Break-in Procedure

- The fireplace should be run three to four hours continuously on high.
- Turn the fireplace off and allow it to completely cool.
- Remove fixed glass assembly. See Section 4.B.
- Clean fixed glass assembly. See Section 4.
- Replace the fixed glass assembly and run continuously on high an additional 12 hours.

This cures the materials used to manufacture the fireplace.

NOTICE! Open windows for air circulation during fireplace break-in.

- Some people may be sensitive to smoke and odors.
- Smoke detectors may activate.

H. Operation During A Power Outage - Intellifire™ Touch

The Intellifire™ Touch intermittent pilot ignition system comes with a battery backup system that enables the system to operate in a power outage. The system offers seamless transition from household AC power to battery backup. A factory-installed battery pack is located in the control cavity of the appliance. See Figure 3.5. Battery longevity and performance will be affected by long term exposure to the service temperatures of this appliance.

NOTICE: Batteries should only be used as a power source in the event of an emergency power outage. Batteries should not be used as a primary long-term power source.

To Operate Fireplace Using Battery Power (DC):

1. Access the control cavity of the appliance. See Figure 3.4 for location.
2. Remove the barrier screen on the indoor side by lifting up and out.
3. Rotate the right hand side panel toward the glass to access the battery tray.
4. Locate the battery tray in the right corner and insert four AA cell batteries. Battery polarity must be correct or module damage will occur. See Figure 3.4. A complete wiring diagram is included in the Electrical section of the appliance Installation Manual.
5. Turn the appliance on according to the instructions below for the appropriate type of control:

Standard Wall Switch or Factory-Installed ON/OFF Switch:

- Toggle the switch as you would under normal circumstances.

Wireless Remote:

- Remote receiver is integrated into the ignition module
- Use the remote to turn the appliance on.

- To preserve battery life, do not use the HI/LO flame or THERMOSTAT options.

Ignition Module:

- Locate the ignition module in the control cavity.
- Slide the ON/REMOTE/OFF switch to the ON position.

NOTICE: Some functionality will be lost when using battery backup including fan, lights, or any other auxiliary functions that require household 110-120 VAC power.

To Return to Operation Using Electrical (AC) Power

Standard Wall Switch or Factory-Installed ON/OFF Switch:

- Toggle the switch to OFF and remove the batteries from the battery tray.
- Remove the barrier screen on the indoor side by lifting up and out.
- Rotate the right hand side panel toward the glass to access the battery tray.

Wireless Remote:

- Slide the ON/REMOTE/OFF switch to the REMOTE position. Remove the batteries from the battery tray.

Ignition Module:

- Slide the ON/REMOTE/OFF switch to the REMOTE position.
- Remove the barrier screen on the indoor side by lifting up and out.
- Rotate the right hand side panel toward the glass to access the battery tray.

Remove the batteries from the battery tray.

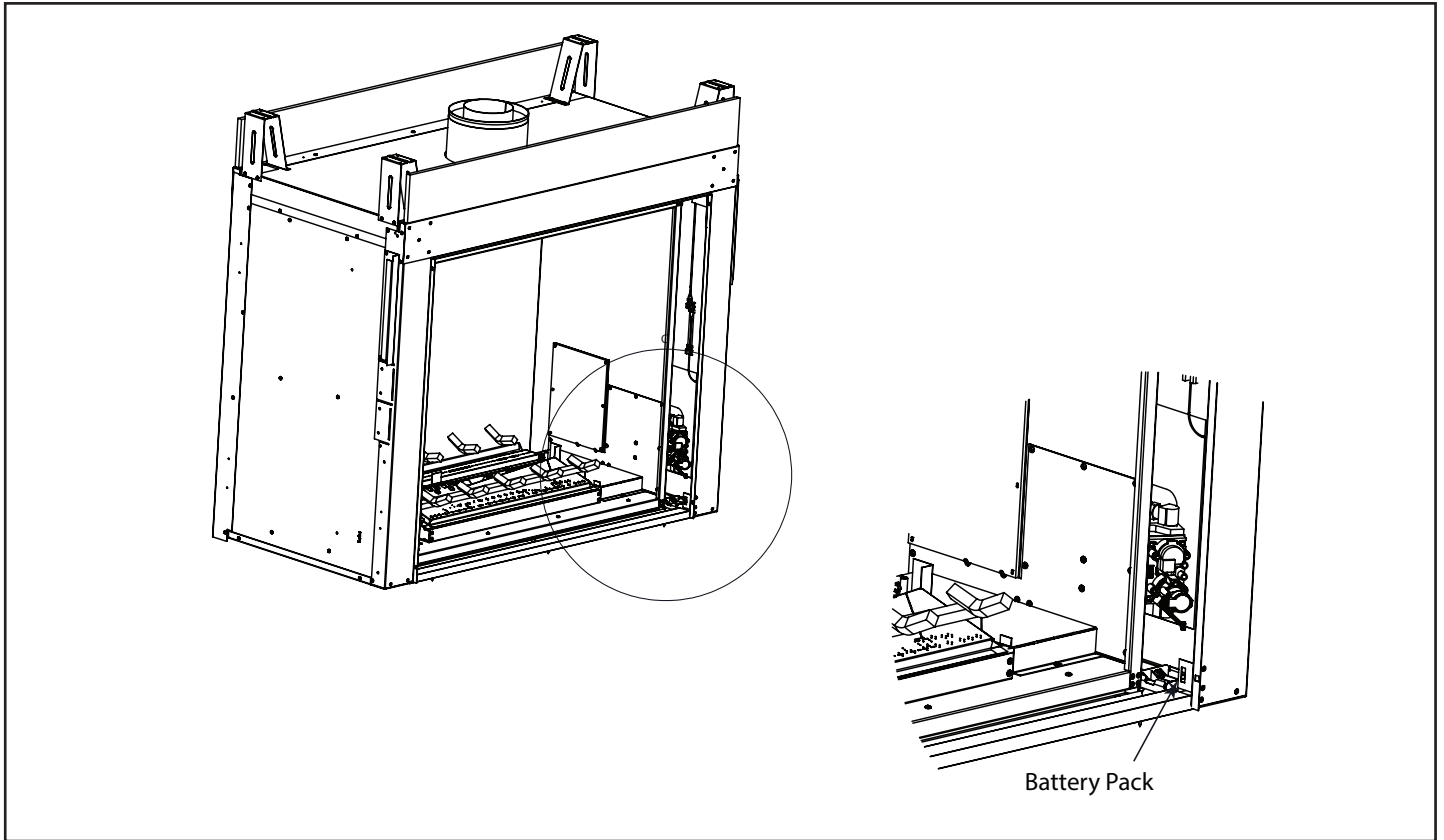

Figure 3.4 Battery Pack Access / Control Cavity Location

I. Access to Control Module

The following steps demonstrate how to access the control module after the unit has been installed: **NOTE: Shut down the unit and allow to cool off.**

1. Remove the barrier screen on the indoor side by lifting up and out. Set aside.
2. Remove the glass door assembly by rotating the two panels toward the glass, unlatch the three latches at the top of the firebox by pulling toward you. Lift up and release. Lift the glass up and out of the bottom door track and set aside.
3. Remove the logs and set aside.
4. Remove the right hand side brick by removing the retaining bracket, tilt the brick into the unit and pull out. Set aside.
5. Remove the access panel to access the control module by unfastening the six screws. See Figure 3.5.

Standard Wall Switch or Factory-Installed ON/OFF Switch:

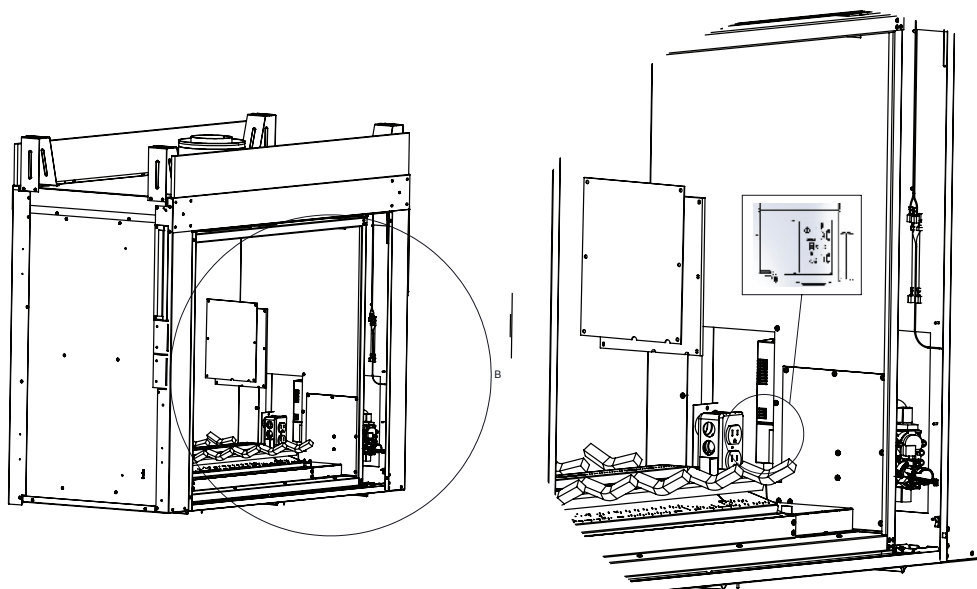

Figure 3.5

J. Detailed Component Operating Instructions - IntelliFire™ Touch

IFT-ECM Detailed Operating Instruction

1. The Electronic Control Module (IFT-ECM) has a three-position ON/OFF/REMOTE selector switch that must be set for proper operation. See Figure 12. When changing switch positions, it is important to pause in each position for 1-2 seconds.

OFF Position:

The appliance will not respond to any commands from a wired wall switch, IFT-RC150 or IFT-RC400 remote controls. The unit should be in the OFF position during installation, service, backup battery installation, fuel conversion and to reset the IFT-ECM in the event the system goes into a LOCK-OUT mode as the result of a system error. When switched to the OFF position while the appliance is operating, the system will shut down.

ON Position:

The appliance will ignite and run continuously at the HI flame setting. No adjustment in flame height is possible.

The IFT-ECM has a safety feature that will automatically shut down the fireplace after 9 hours of continuous operation in the ON position.

Remote Position:

The remote position allows operation of the appliance from a wired wall switch, IFT-RC400 or IFT-RC150 remote controls. The IFT-ECM switch must be in this position to pair the IFT-ECM with the IFT-ACM (if installed), and/or IFT-RC400 and IFT-RC150 remote controls. See the IFT-RC400 or IFT-RC150 installation manual for detailed instructions on pairing the IFT-ECM with the remote controls. After successfully pairing a IFT-RC400, all installed accessories can be controlled by the IFT-RC400 (see IFT-RC400 user manual). The RC150 allows the user to turn ON/OFF the flame in the appliance and activate the Cold Climate mode if desired. The IFT-ECM has a safety feature that will automatically shut down the fireplace after 9 hours of continuous operation without receiving a command from the IFT-RC400 or IFT-RC150.

2. If multiple control options are installed, the IFT-ECM will respond to the last command from the wired wall switch, IFT-RC400 or IFT-RC150. The wired wall switch is NOT available if a Power Vent is used.
3. The Pilot button on the IFT-ECM activates the Cold Climate function of the fireplace. This function lights the pilot flame ONLY to provide enough heat in the firebox to reduce condensation in cool, high humidity ambient conditions. To activate the Cold Climate press and hold the Pilot button for one second and release. The IFT-ECM will flash two green LED blinks, beep twice and light and rectify the pilot flame when pressed to activate. To turn off Cold Climate, press and hold the Pilot button for one second and release. The IFT-ECM will flash one green LED blink, beep once and shut down the pilot flame. If remote controls are paired with the IFT-ECM, this feature can also be activated with the IFT-RC400 and/or IFT-RC150.
4. An IFT-ECM reset is required if the module is in a lock-out condition. When this occurs, the appliance is shut down and the IFT-ECM status indicator LED will be blinking a RED/GREEN error code along with a one-time audible double- beep. If the IFT-ECM is in a lock-out condition, refer to the troubleshooting chart to interpret the error code and take corrective action as required. To reset the IFT-ECM after a lock-out error:

CAUTION! Risk of burns! Appliance surfaces are hot when operating and during cool down. Use care and wear gloves when opening the front and accessing components inside the appliance.

- Be aware the appliance may be HOT, use care in accessing the IFT-ECM.
- Set the IFT-ECM 3-position selector switch to OFF position.
- Wait five (5) minutes to allow possible accumulated gas to clear.
- Set the IFT-ECM 3-position selector switch to ON or IFT-REM position. Module will beep once and flash a three GREEN LED code on successful startup.
- If placed in ON position, the appliance will ignite normally if the error condition was corrected.
- If placed in IFT-REM position, use the paired IFT-RC400, IFT-RC150 or wired wall switch to start the appliance; appliance will ignite normally if the error condition was corrected.
- If the IFT-ECM re-enters the lock-out condition after these steps, call your dealer for service.

Appliance ON/OFF:

Your ODFORTG-36 fireplace is supplied with a fully functional remote control. This remote controls:

- ON/OFF Functions
- Flame height adjustments
- Thermostat
- Accent Lights
- Cold Climate Feature

Please refer to the instructions included with the remote control for more detailed operating instructions.

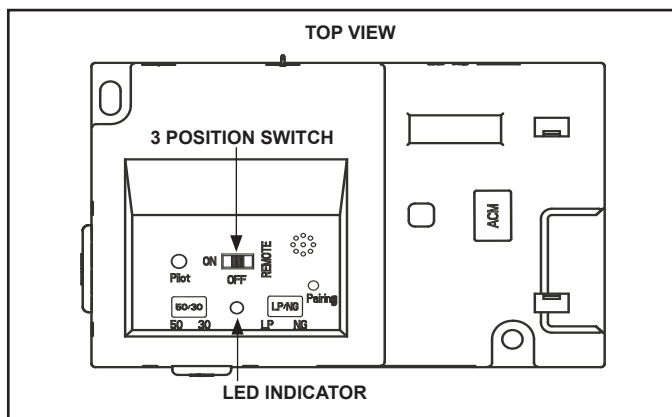

Figure 3.6 IFT-ECM

DANGER

Risk of Explosion

DO NOT cycle the ON/OFF/REM selector switch more than one time within a five minute period. Gas may accumulate in firebox. Call a qualified service technician.

4 Maintenance and Service

Any safety screen or guard removed for servicing must be replaced prior to operating the fireplace.

When properly maintained, your fireplace will give you many years of trouble-free service. **Contact your dealer** to answer questions regarding proper operation, troubleshooting and service for your appliance. Visit www.OutdoorLifestylesproducts.com to locate a dealer. We recommend annual service by a qualified service technician.

A. Maintenance: Frequency and Tasks

Task	Frequency	To be completed by
Glass Cleaning (interior)	Seasonally	Homeowner
Remote Control	Seasonally	
Venting	Seasonally	
Glass Cleaning (exterior)	Annually	Qualified Service Technician
Gasket Seal and Glass Inspection	Annually	
Log Inspection	Annually	
Firebox Inspection	Annually	
Control Compartment & firebox Top	Annually	
Burner Ignition & Operation	Annually	
Light Bulbs	As needed	
Firebox (FireBrick)	Annually	

B. Maintenance Tasks - Homeowner

Installation and repair should be done by a qualified service technician only. The appliance should be inspected before use and at least annually by a professional service person.

The following tasks may be performed annually by the homeowner. If you are uncomfortable performing any of the listed tasks, please call your dealer for a service appointment.

More frequent cleaning may be required due to excessive lint from carpeting, bedding material, et cetera. It is imperative that control compartments, burners and circulating air passageways of the appliance be kept clean. Any safety screen, guard, or barrier removed for servicing the appliance must be replaced prior to operating the appliance.

CAUTION! Risk of Burns! The fireplace shall be turned off and cooled before servicing.

Glass Cleaning (Interior) (Exterior of Installed Glass Only)

Frequency: Seasonally

By: Homeowner

Tools Needed: Protective gloves, glass cleaner, drop cloth and a stable work surface.

WARNING! Risk of Injury! Glass installation and removal should be performed only by a qualified service technician.

- Homeowner may only clean outsides of glass.
- Call your dealer for a service appointment to have inside of glass cleaned.

CAUTION! Glass is breakable.

- Avoid striking, scratching or slamming glass
- Avoid abrasive cleaners
- **DO NOT** clean glass while it is hot
- Remove the barrier screen by lifting up and out.
- Rotate the right and left panels toward the glass.
- Remove glass by unlatching the three latches at the top of the glass, pulling the latches away from the glass up and release back in.
- Lift glass up and out of the bottom track.
- Clean glass with a non-abrasive commercially available cleaner. Also clean second glass from inside the fireplace.
 - Light deposits: Use a soft cloth with soap and water
 - Heavy deposits: Use commercial fireplace glass cleaner (consult with your dealer)

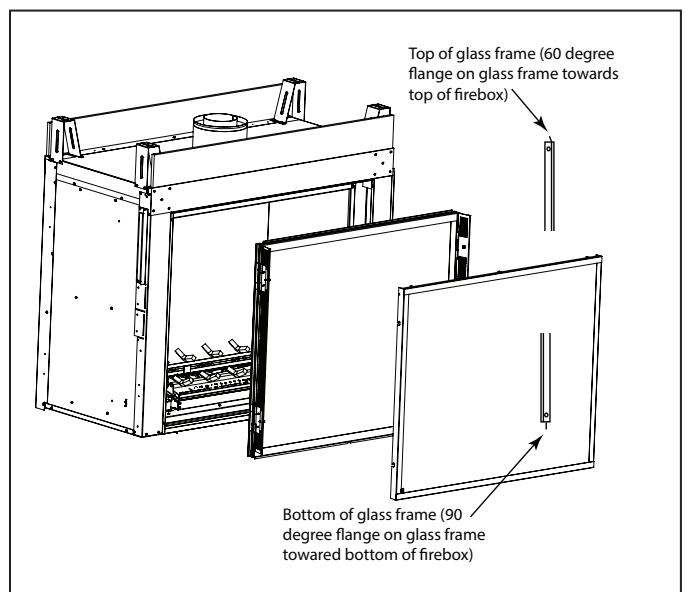

► Figure 4.1 Interior Glass Cleaning

Remote Control

Frequency: Seasonally

By: Homeowner

Tools needed: Replacement batteries and remote control instructions.

- Locate remote control transmitter and receiver.
- Verify operation of remote. Refer to remote control operation instructions for proper calibration and setup procedure.
- Place batteries as needed in remote transmitters and battery-powered receivers.
- Place remote control out of reach of children.

If not using your fireplace for an extended period of time (summer months, vacations/trips, etc), to prevent unintended operation:

- Remove batteries from remote controls.
- Unplug 6 volt adapter plug on IPI models.

Venting

Frequency: Seasonally

By: Homeowner

Tools needed: Protective gloves and safety glasses.

- Inspect venting and termination cap for blockage or obstruction such plants, bird nests, leaves, snow, debris, etc.
- Verify termination cap clearance to subsequent construction (building additions, decks, fences, or sheds).
- Inspect for corrosion or separation.
- Verify weather stripping, sealing and flashing remains intact.
- Inspect draft shield to verify it is not damaged or missing.

C. Maintenance Tasks - Qualified Service Technician

The following tasks must be performed by a qualified service technician.

Glass Cleaning

(Exterior and Interior of Installed Glass)

Frequency: Seasonally

By: Qualified Service Technician

Tools Needed: Protective gloves, glass cleaner, drop cloth and a stable work surface.

WARNING! Risk of Injury! Glass installation and removal should be performed only by a qualified service technician.

CAUTION! Handle fixed glass assembly with care. Glass is breakable.

- Avoid striking, scratching or slamming glass
 - Avoid abrasive cleaners
 - **DO NOT** clean glass while it is hot
- Prepare a work area large enough to accommodate fixed glass assembly and door frame by placing a drop cloth on a flat, stable surface.

Note: Fixed glass assembly and gasketing may have residue that can stain carpeting or floor surfaces.

- Remove barrier screen from fireplace and set aside on work surface.
- See Section 11.A in the installation manual for instructions to remove fixed glass assembly.
- Clean glass with a non-abrasive commercially available cleaner.
 - Light deposits: Use a soft cloth with soap and water
 - Heavy deposits: Use commercial fireplace glass cleaner (consult with your dealer)
- Carefully set fixed glass assembly in place on fireplace. Hold glass in place with one hand and secure glass latches with the other hand.
- Reinstall barrier screen.

Glass Cleaning Exterior (outdoor)

- Remove the top trim at the top of the stainless steel outdoor decorative face. See Figure 4.2.
- Remove the stainless steel decorative face by lifting up and out.
- Remove the exterior glass door by unfastening the top four machine bolts, the two side bolts, and the two bottom corner bolts. Loosen the two middle bottom bolts but do not remove totally to help support the assembly.
- Lift glass up and out. See Figure 4.2.
- Clean glass with a non-abrasive commercial cleaner on both sides and clean the outdoor side of the second glass.

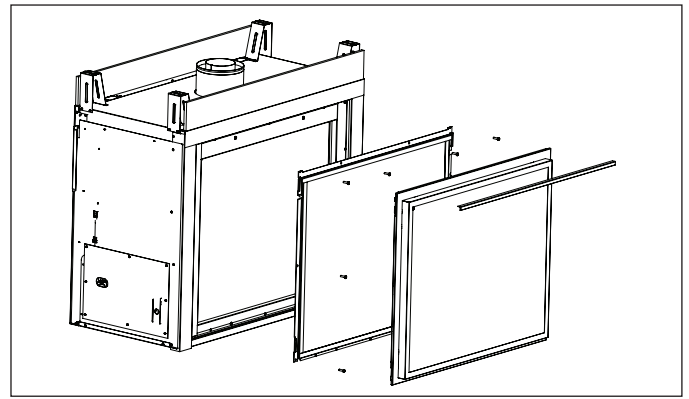

Figure 4.2 Exterior Glass Cleaning

- Replace in reverse order after cleaning.

Gasket Seal and Glass Assembly Inspection

Frequency: Annually

By: Qualified Service Technician

Tools needed: Protective gloves, drop cloth and a stable work surface.

- Inspect gasket seal and its condition.
- Inspect fixed glass assembly for scratches and nicks that can lead to breakage when exposed to heat.
- Confirm there is no damage to glass or glass frame. Replace as necessary.
- Verify that fixed glass assembly is properly retained and attachment components are intact and not damaged. Replace as necessary.

Logs

Frequency: Annually

By: Qualified Service Technician

Tools needed: Protective gloves.

- Inspect for damaged or missing logs. Replace as necessary. Refer to Installation manual for log placement instructions.
- Verify correct log placement and no flame impingement causing sooting. Correct as necessary.

Firebox Inspection

Frequency: Annually

By: Qualified Service Technician

Tools needed: Protective gloves, sandpaper, steel wool, cloths, mineral spirits, primer and touch-up paint.

- Inspect for paint condition, warped surfaces, corrosion or perforation. Sand and repaint as necessary.
- Replace fireplace if firebox has been perforated.

Control Compartment and Firebox Top

Frequency: Annually

By: Qualified Service Technician

Tools needed: Protective gloves, vacuum cleaner, dust cloths

- Vacuum and wipe out dust, cobwebs, debris or pet hair. Use caution when cleaning these areas. Screw tips that have penetrated the sheet metal are sharp and should be avoided.
- Remove all foreign objects.
- Verify unobstructed air circulation.

Burner Ignition and Operation

Frequency: Annually

By: Qualified Service Technician

Tools needed: Protective gloves, vacuum cleaner, whisk broom, flashlight, voltmeter, indexed drill bit set, and a manometer.

- Verify burner is properly secured and aligned with pilot or igniter.
- Clean off burner top, inspect for plugged ports, corrosion or deterioration. Replace burner if necessary.
- Replace Glowing embers with new dime-size pieces. **DO NOT** block ports or obstruct lighting paths. Refer to appliance installation manual for proper ember placement.
- Verify batteries have been removed from battery back-up IPI systems to prevent premature battery failure or leaking.
- Check for smooth lighting and ignition carryover to all ports. Verify that there is no ignition delay.
- Inspect for lifting or other flame problems.
- Verify air shutter setting is correct. See Installation Manual for required air shutter setting. Verify air shutter is clear of dust and debris.
- Inspect orifice for soot, dirt and corrosion. Verify orifice size is correct. See Service Parts List for proper orifice sizing.
- Verify manifold and inlet pressures. Adjust regulator as required.
- Inspect pilot flame pattern and strength. See Figures 4.3 for proper pilot flame pattern. Clean or replace orifice spud as necessary.
- Inspect IPI flame sensing rod for soot, corrosion and deterioration. Polish with fine steel wool or replace as required.
- Verify that there is not a short in flame sense circuit by checking continuity between pilot hood and flame sensing rod. Replace pilot as necessary.

Light Bulb Maintenance

Frequency: As needed

By: Qualified Service Technician

Tools needed: Protective gloves, replacement light bulbs.

- See Section 11 of appliance installation manual.

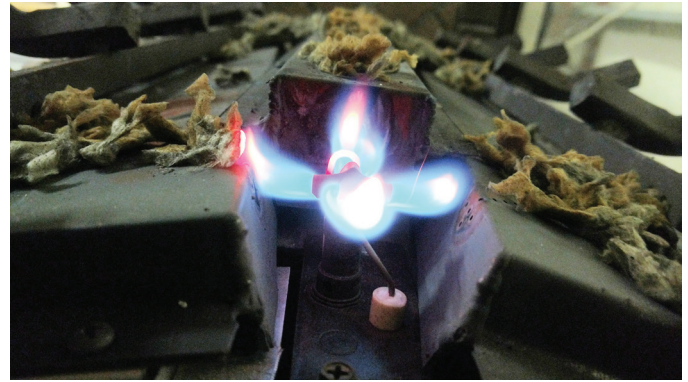

Figure 4.3 IPI Pilot Flame Patterns

NOTE: Appearance of rock jig, pilot shield and media tray may vary between appliance models.

Burner Flame

The flames from the burner should be visually checked as soon as the heater is installed and periodically during normal operation. In normal operation, at full rate, and after operating for about 15 to 30 minutes, the flame should be yellow and slightly taller than the rear log. See Figure 4.4. If the flame is blue and only in the center, turn off unit and let cool. After unit is cool, remove logs and check to make sure the back holes in the burner are not covered with rock wool. If the back holes are clear, add more rock wool to the center of the burner.

NOTE: The type of installation, vent system configuration and wind effects may cause the flame patterns to vary.



Figure 4.4 Burner Flame Appearance

5 Frequently Asked Questions and Troubleshooting

A. Frequently Asked Questions - Appliance

ISSUE	SOLUTIONS
Condensation on the glass	This is a result of gas combustion and temperature variations. As the fireplace warms, this condensation will disappear.
Blue flames	This is a result of normal operation and the flames will begin to yellow as the fireplace is allowed to burn for 20 to 40 minutes.
Odor from fireplace	When first operated, this fireplace may release an odor for the first several hours. This is caused by the curing of the paint and the burning off of any oils remaining from manufacturing. Odor may also be released from finishing materials and adhesives used around the fireplace.
Film on the glass	This is a normal result of the curing process of the paint and logs. Glass should be cleaned within 3 to 4 hours of initial burning to remove deposits left by oils from the manufacturing process. A non-abrasive cleaner such as gas fireplace glass cleaner may be necessary. See your dealer.
Metallic noise	Noise is caused by metal expanding and contracting as it heats up and cools down, similar to the sound produced by a furnace or heating duct. This noise does not affect the operation or longevity of the fireplace.
Is it normal to see the pilot flame burn continually?	In an intermittent pilot ignition system (IPI), the pilot flame should turn off when appliance is turned off. Some optional control systems available with IPI models may allow pilot flame to remain lit.
Rock Media Kit	There may be some "cracking" noise coming from the fireplace during the first few heating and cooling cycles. This noise is associated with settling rock and some minor cracking of larger pieces of rock. This will lessen over time as the glass rock is conditioned to the heating and cooling temperature changes.
	It is expected that a few small pieces (approximately 10 pieces) of rock may fall through the base pan and come to rest on the fireplace bottom. This has no effect on fireplace performance.
Power Outages (battery backup)	This appliance can be operated on battery power in the event of a power outage. To access the battery pack, the decorative front, mesh and glass assembly must be removed. Refer to Section 3 for more details.
Wall above appliance feels hot to the touch.	No action necessary. This appliance ships with a non-combustible material attached. Specifications of the attached non-combustible material are listed in the Installer's Manual for this appliance.

► **B. Frequently Asked Questions - IntelliFire Touch Controls (Optional IFT-RC400)**

Symptom	Possible Cause	Corrective Action
The appliance does not respond to commands from the remote control display does not light up when screen is touched.	Batteries are depleted.	Verify batteries are new.
	Batteries are incorrectly oriented.	Verify batteries are installed in correct orientation as shown on batteries receptacle.
The display on remote lights up when screen is touched but it does not respond to commands.	Touchscreen has lost calibration.	Touchscreen needs to be re-calibrated. Call dealer to have screen re-calibrated.
	Child Lock is ON.	Check child lock icon located at the top of the remote display. If ON, it will show as a 'locked' symbol. To unlock, remove battery compartment door, locate child lock switch and move to 'unlock' position. Verify child lock icon on screen is now displayed in 'unlock' position.
The remote displays the following message on-screen: No dealer info available	Dealer information not programmed into remote.	Remote will still provide all available functions, and appliance is fully available for use. Call dealer to have them program.
The remote displays the following message on-screen: Call "Dealer Name & Number" to schedule maintenance.	300 hours of use. Appliance is still fully functional.	The appliance has been burning for 300 hours and is due for a regular maintenance. Call dealer to have them perform maintenance.
The room temperature displayed on the remote is either slow or quick to respond while operating in thermostat mode.	Remote is placed at a very short distance or too far away from the appliance.	Try to keep the remote close to the appliance but not directly in front of it. The remote acts as the thermostat.
	Remote is placed in the path of an air draft or vent.	Move the remote away from the direct path of air flow. The remote acts as the thermostat.
	Flame Modulation	The control system is designed to automatically adjust the flame intensity based on the difference between the desired room temperature, and actual temperature. In thermostat mode, the hearth appliance will start in HI flame, but as the actual temperature approaches the desired set temperature on the remote, the flame intensity will automatically decrease. Automatic flame modulation will result in more control of the temperature, and will cause the appliance to cycle OFF/ON less.
The appliance turns OFF the flame after extended periods of operation	9 hour safety shutdown timer	This is normal behavior. The appliance has a safety timer that will automatically turn OFF the flame after nine hours of uninterrupted operation.
The remote displays the following message on-screen: Fan will turn on within 3 minutes	Functioning as intended.	The appliance has a three minute delay timer before the fan is turned ON. This allows the air surrounding the appliance to be heated before being pushed into the room.
The remote displays the following message on-screen: "Replace remote batteries."	Low batteries in remote.	Install new batteries in the remote.
The remote is displaying an incorrect brand.	Remote was programmed incorrectly.	Call dealer to have them program the remote with correct branding. Remote is still fully functional and the appliance is unaffected.
After turning flame ON using remote, the flame does not turn ON immediately and instead a two minute timer is displayed.	Power vent is installed on the appliance.	This is expected behavior and the two minute timer is called a pre-purge timer. The flame will turn ON at the expiration of the timer.
The remote displays the following message on-screen: "Remote Control Communication Error."	No power to appliance.	Verify home circuit breaker is on and master reset is on (if equipped).
	Power outage.	Install new batteries in battery backup.
The remote displays the following message on -screen: Sorry your appliance did not start. Try again by pressing Flame On.	No power to appliance. No gas to appliance. Accumulation of air in gas line from extended period of appliance inactivity. Gas control system failure.	Verify that appliance has power and gas. Verify that the appliance accepts flame ON commands with an audible beep, and successfully turns flame on within 90 seconds. If this failure persists, contact dealer for service.

C. Troubleshooting

With proper installation, operation, and maintenance your gas appliance will provide years of trouble-free service. If you do experience a problem, this troubleshooting guide will assist a qualified service technician in the diagnosis of a problem and the corrective action to be taken. This troubleshooting guide can only be used by a qualified service technician. Contact your dealer to arrange a service call by a qualified service technician.

IntelliFire Touch

Error Codes:

ECM LED Error Codes	Description
3 Red: 1 Green	IFT-RC400 error message: 'Appliance Safely Disabled', pilot sparks for 90 sec, no flame rectification.
2 Red: 1 Green	IFT-RC400 display: 'Error Pilot Flame', pilot valve solenoid not detected.
2 Red: 2 Green	Sparkling feedback signal error, spark coil failure.
5 Red: 1 Green	IFT-RC400 display: 'Error Power Vent' (if installed).

See Troubleshooting matrix for more detail on Lock-out Error Codes, Possible Causes and Corrective Actions.

Troubleshooting:

Symptom	Possible Cause	Corrective Action
Pilot won't light, module clicks but no spark 90 sec, 3 Red/1 Green Lock out.	Incorrect wiring.	Verify 'S' (White) sense wire and 'I' (orange) ignitor wire are connected to correct terminals on IFT-ECM.
	Loose connections or electrical shorts in wiring.	Verify no loose connections or electrical shorts in wiring from module to pilot assembly. Verify wire insulation is not damaged. Verify wires are not grounding out to chassis, pilot burner, or any other metal object. Replace any damaged wires.
	Ignitor gap is too large.	Verify spark gap is approximately 0.095" (2.41 mm) to 0.135" (3.43 mm).
Pilot won't light, there is no noise or spark.	No AC power, AC/DC adaptor faulty, backup batteries (if being used) depleted, IFT-ECM slider switch in OFF position.	Verify IFT-ECM slider switch is in ON or REM position. Verify AC power available to junction box. Verify AC/DC adaptor is plugged into junction box and ECM. Verify AC/DC adaptor output voltage is between 5.7-6.3 Vdc. If battery pack is used, check battery pack voltage is >4.2 V (if not, replace batteries).
	Shorted or loose connection in system wiring or wiring harness.	Verify system wiring configuration. Remove and reinstall wiring harness that plugs into module. Check continuity of wires in valve wiring harness. Replace any damaged components.
	Poor or no system ground.	Verify black ground wire in valve harness is connected to metal chassis of fireplace.
Pilot won't light, there is no noise or spark, 2 Red/1 Green Lockout.	Pilot solenoid not detected.	Check if valve harness orange wire is connected to pilot solenoid valve. Check pilot solenoid resistance, nominal is 40 ohms. If open or shorted, replace valve. Check valve harness wire continuity, if open replace 6-pin harness.
Pilot won't light, there is no noise or spark, 2 Red/2 Green Lockout.	Spark coil failure.	Replace ECM.

IntelliFire Touch - (continued)

Symptom	Possible Cause	Corrective Action
Pilot sparks but does not light, after 90 sec, 3 Red/1 Green Lockout	No gas supply.	Verify incoming gas line ball valve is 'Open'. Verify inlet pressure is within requirement for gas type used. Contact gas supplier.
	ECM has poor ground.	Verify wiring, check valve harness black wire is securely grounded to metal chassis.
	Gas valve defective.	Check pilot valve solenoid kick and hold voltages during ignition cycle. Kick V should be >1 V, hold V minimum 0.26 V. If voltages are OK, replace gas valve.
Pilot lights but main burner does not light. Pilot continues to spark for 90 sec then goes into 3 Red/1 Green Lockout.	No flame detected. Flame rectification issue.	Check if white sense lead is securely connected to 'S' terminal of IFT-ECM. Check resistance of sense lead between sense rod tip and connector to IFT-ECM, should be less than 1 ohm - if not, replace pilot assembly. Check system ground, ensure black valve harness wire is securely attached to metal chassis. Check wiring for damage. With system OFF, check resistance between tip of sense rod and pilot hood, should be resistance (>1 M-ohm).
	No flame detected or sense rod contamination.	With glass assembly installed, verify pilot flame is engulfing flame sense rod on pilot assembly. Verify inlet gas pressure is correct for gas type. Polish flame sense rod with fine steel wool to remove any contaminants that may have accumulated.
Pilot lights and rectifies, but main burner does not light.	Main valve solenoid.	Check if green wire in valve harness is connected to green main valve solenoid. Check main valve solenoid resistance, nominal is 60 ohms. If open or shorted, replace valve. Verify valve inlet pressure is correct for gas type.
Pilot and main do not light, ECM goes into 5 Red/1 Green Lockout.	Power Vent (PV) Failure.	Power Vent blower defective - check wiring to IFT-ACM, check if blower is working. Check if PV pressure switch is connected to brown and black wire in 6-pin valve wire harness. Check if pressure switch is closed (shorted) when PV blower is running. Refer to PV troubleshooting instructions.
Appliance lights and runs for a few minutes then shuts down and/or appliance cycle ON and OFF with less than 90 sec of ON time.	Shorted or loose connection in flame detection circuit.	Check if white sense lead is securely connected to 'S' terminal of IFT-ECM. Check resistance of sense lead between sense rod tip and connector to IFT-ECM, should be less than 1 ohm - if not, replace pilot assembly. Check system ground, ensure black valve harness wire is securely attached to metal chassis. Check wiring for damage. With system OFF, check resistance between tip of sense rod and pilot hood, should be resistance (>1 M-ohm).
	Poor flame rectification or contaminated sense rod.	With glass assembly installed, verify pilot flame is engulfing flame sense rod on pilot assembly. Verify inlet gas pressure is correct for gas type. Polish flame sense rod with fine steel wool to remove any contaminants that may have accumulated. Verify no soot deposits are in sense rod to pilot hood gap.
	Logs are set up wrong.	Remove and re-install logs per the log placement instructions.
	Damaged pilot assembly.	Verify the pilot assembly ceramic insulator around the flame sensing rod is not cracked, damaged or loose. Check resistance between tip of sense rod and IFT-ECM connector, should be less than 1 ohm. Replace pilot assembly if damage is detected.

6 Reference Materials

A. Accessories

Install approved accessories per instructions included with accessories. Contact your dealer for a list of approved accessories.

WARNING! Risk of Fire and Electric Shock! Use ONLY Hearth & Home Technologies-approved optional accessories with this appliance. Using non-listed accessories could result in a safety hazard and will void the warranty.

Remote Controls, Wall Controls and Wall Switches

After a qualified service technician has installed the remote control, wall control or wall switch, follow the instructions supplied with the control installed to operate your fireplace:

For safety:

- Install a switch lock or a wall/remote control with child protection lockout feature.
- Keep remote controls out of reach of children.

See your dealer if you have questions.

► B. Service Parts



Service Parts

ODFORTG-36

Fortress 36" Outdoor Gas Fireplace

Beginning Manufacturing Date: Feb 2017
Ending Manufacturing Date: Active

Log Assembly

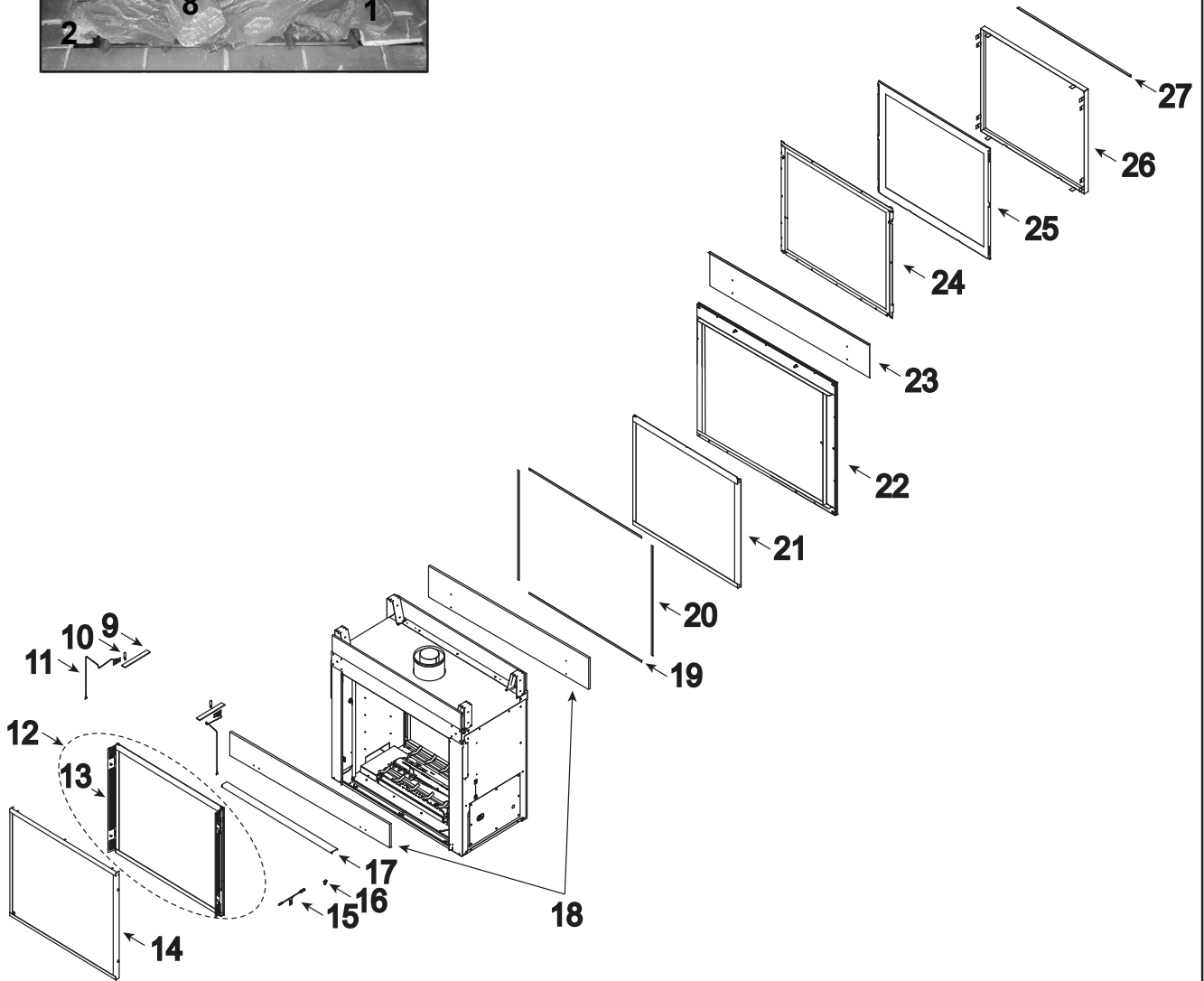

Part number list on following page.

02/20

#28 Valve Assembly

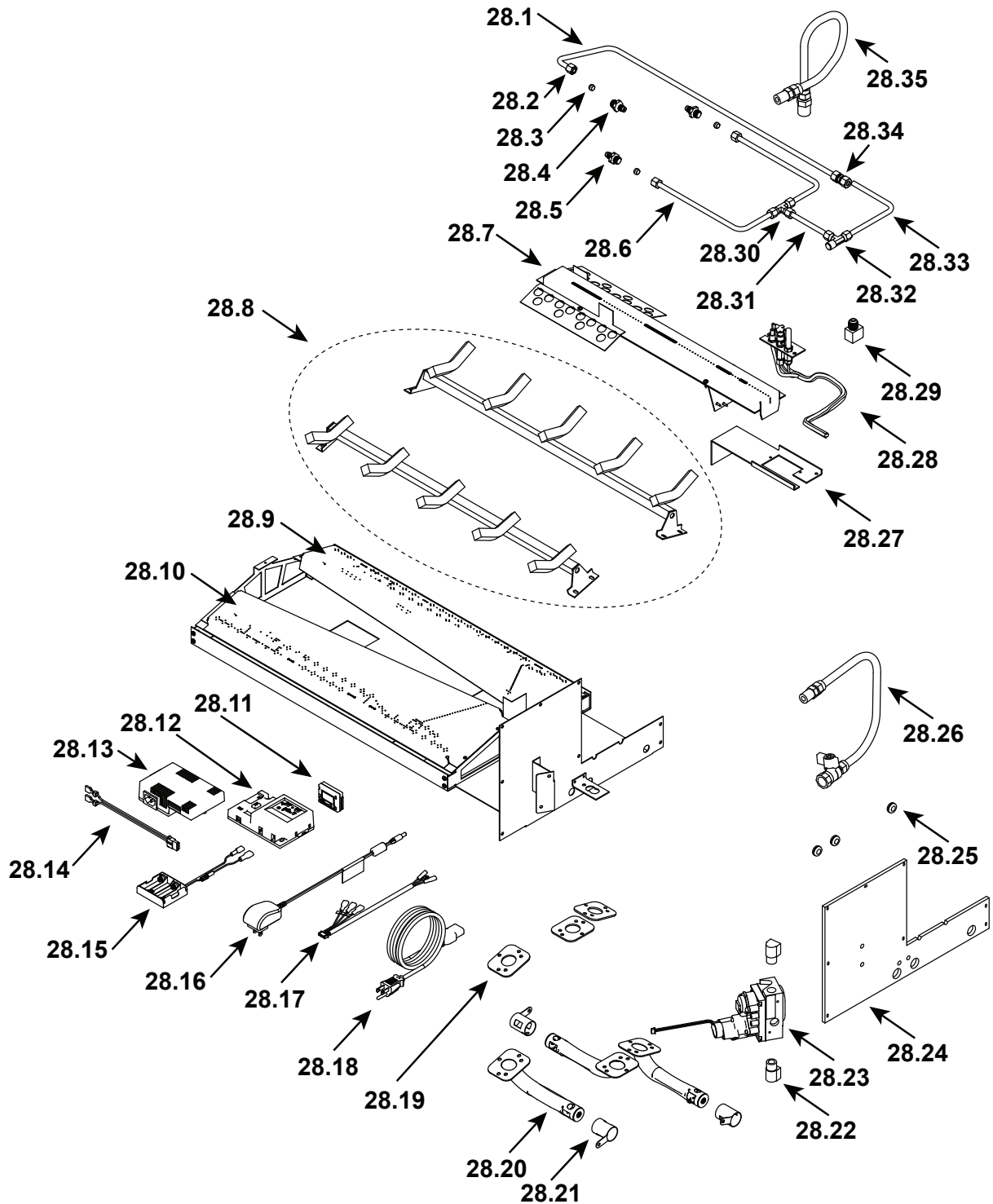

IMPORTANT: THIS IS DATED INFORMATION. Parts must be ordered from a dealer or distributor. **Hearth and Home Technologies does not sell directly to consumers.** Provide model number and serial number when requesting service parts from your dealer or distributor.



Stocked
at Depot

ITEM	DESCRIPTION	COMMENTS	PART NUMBER	
28.1	Tube, Solenoid to Mid burner		73D4061K	Y
28.2	Nut, 1 1/2 UNF, 5/16	Qty 3 req	SRV00K0917	Y
28.3	Ferrule 5/16	Qty 3 req	00K918	Y
28.4	Injector NG Drill #31		SRV70D0064	Y
28.5	Injector NG Drill #46	Qty 2 req	SRV20H3150	Y
28.6	Tube, Tee to Front Burner	Qty 2 req	73D4062	Y
28.7	Center Burner Assembly		SRV4602-005	Y
28.8	Weldment, Grate	Qty 2 req	73D4516	
28.9	Weldment, Burner Front #2		73D4507	Y
28.10	Weldment, Burner Front #1		73D4508	Y
28.11	Module, RF FCC		2326-120	Y
28.12	Module, Control IFT		SRV2326-130	Y
28.13	AUX Module, B-Type		2326-150	Y
28.14	Lighting Harness		SRV4601-201	Y
28.15	** Battery Pack		SRV2326-134	Y
28.16	Transformer, 6 Volt Wall		SRV2326-131	Y
28.17	Harness, IFT 6 Pin Wiring		SRV2326-132	Y
28.18	Cable, B Type AC Module		SRV2326-152	Y
28.19	Gasket, Venturi DV	Qty 3 req	SRV45D0032	Y
28.20	Venturi w/Screw	Qty 3 req	SRV69D1026	Y
28.21	Air Shutter	Qty 3 req	SRV69D1027	Y
28.22	Elbow-Street 3/8" x 3/8" 90 Degree	Qty 2 req	69882	Y
28.23	Valve, IPI NG		2166-302	Y
	Valve, IPI Propane		2166-303	Y
28.24	Engine Gasket		SRV4602-204	Y
28.25	Grommet, Split	Qty 3 req	2146-420	
28.26	Flexline, 18" w/Shutoff Valve		SRV69D0030	Y
28.27	Pilot Sheild		SRV4602-153	
28.28	4 Way PSE Pilot, NG		SRV4602-300	Y
28.29	Brass Elbow, 3/8" Flare x 1/4" FPT		73D0127	Y
28.30	Brass Tee, 5/16" Compression		SRV43D0181	Y
28.31	Straight Tube, .313 Diameter x 4.562		SRV4602-104	Y
28.32	Brass Tee, 5/16" Compression x 1/4" MPT		73D0126	Y
28.33	Tube, Venturi to Flex Outlet 90		SRV4602-154	Y
28.34	Fitting Brass, Union 5/16" Compression		37D0713	Y
28.35	10-2131-18 SS Flex Hose		20H0022	Y

**Fuse for battery pack can be sourced locally, not a warranty item. Specs are 250v, 3A fuse, 3/4" long

Additional service part numbers appear on following page.

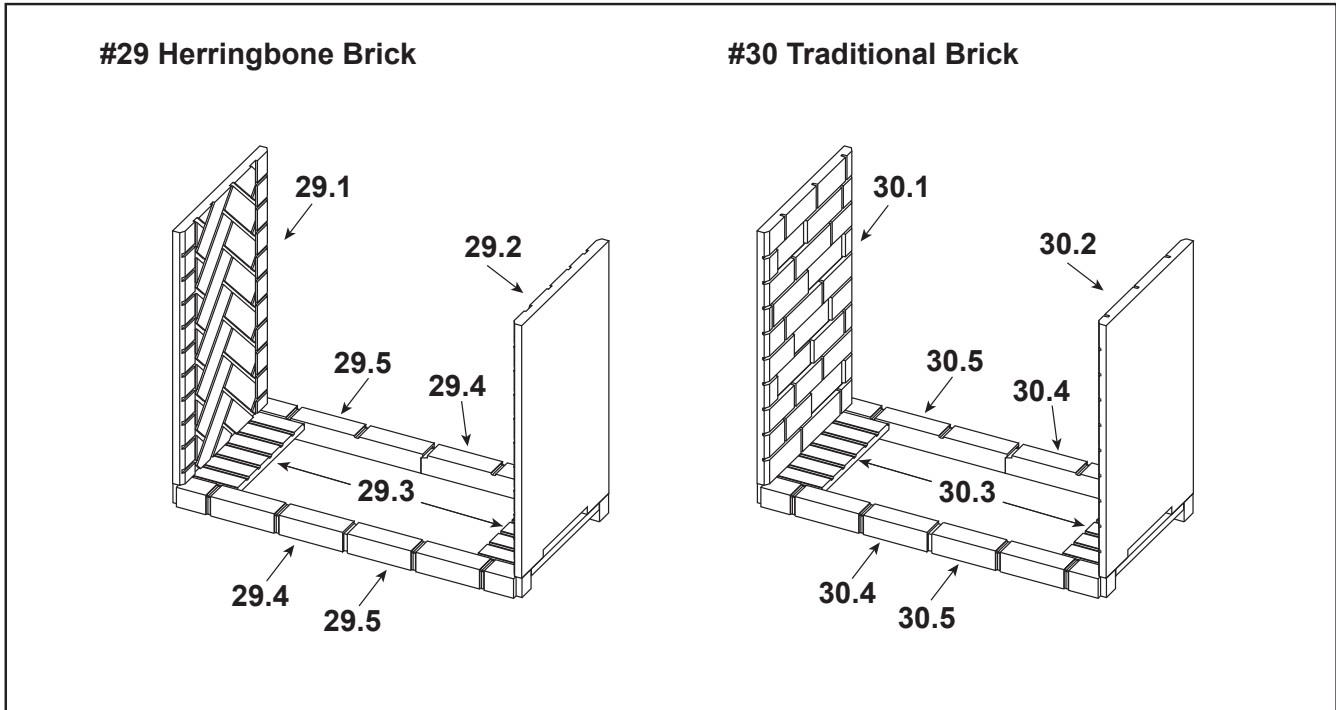

IMPORTANT: THIS IS DATED INFORMATION. Parts must be ordered from a dealer or distributor. **Hearth and Home Technologies does not sell directly to consumers.** Provide model number and serial number when requesting service parts from your dealer or distributor.



Stocked at Depot

ITEM	DESCRIPTION	COMMENTS	PART NUMBER	
29	Brick, Herringbone		ODFORTG36-IH	
29.1	Brick, Wall Engine Side		73D4143K	
29.2	Brick, Wall Air Side		73D4144K	
29.3	Brick, Floor	Qty 2 req	73D4145K	
29.4	Brick, Front Left	Qty 2 req	73D4146K	
29.5	Brick, Front Right	Qty 2 req	73D4147K	
30	Brick, Traditional		ODFORTG36-IT	
30.1	Brick, Wall Engine Side		73D4149K	
30.2	Brick, Wall Air Side		73D4150K	
30.3	Brick, Floor	Qty 2 req	73D4151K	
30.4	Brick, Front Left	Qty 2 req	73D4152K	
30.5	Brick, Front Right	Qty 2 req	73D4153K	
	Remote, RC400		SRV2326-110	
Conversion Kits				
	Conversion Kit NG		N/A	
	Conversion Kit Propane		LPK-ODFORTG-36	Y
	Pilot Orifice, Propane		SRV4602-301	Y
	Injector MED VF Front		SRV58D0056	Y
	Injector EDVLIN Drill #5		57D0608	Y
	Regulator, Propane		SRVLPK-DXV-50	Y

C. IFT-RC400 User Guide

IFT-RC400 IntelliFire™ Touch Remote Control

The Screen, Functions and Indicators sections of the IFT-RC400 User Guide are included in this section for reference.

NOTE: For additional information, refer to the IFT-RC400 Installation and Operating Instructions or visit www.fireplaces.com/IFT-RC400demo to view the IFT-RC400 demo video.

Introduction

This user guide serves as a quick reference to the screen, functions and indicators on your IntelliFire™ Touch Remote control.

SCREEN

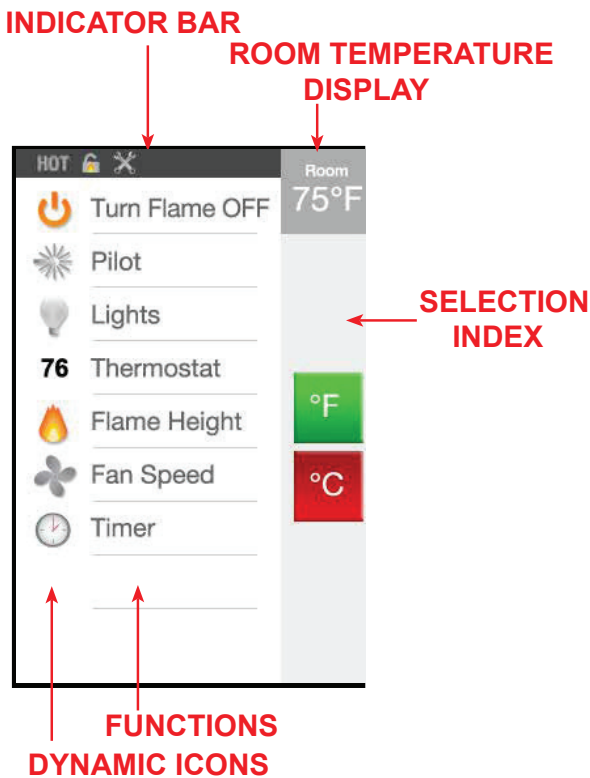

FUNCTIONS

Turn Flame On/Off

Toggle this function to turn ON or OFF your appliance.

Thermostat

You can set and maintain your desired room temperature with the thermostat function. This function automatically adjusts your appliance to maintain the desired set temperature (ST).

To achieve the most accurate thermostat function, locate your IFT-RC400 remote control in the same general space that you want to have temperature controlled by your appliance. For best results, keep your IFT-RC400 remote away from direct radiant heat from the appliance, adjacent windows and doors, HVAC vents, and direct sunlight.

To use the thermostat function, access the main menu screen on your remote, and select thermostat. Next, simply select your desired set temperature by using the arrow keys and press ON to confirm the setting. The actual room temperature (RT), measured by your IFT-RC400 remote, will be displayed in the upper right corner of the main menu screen. To turn the thermostat function off, simply select thermostat on the main menu screen and select OFF.

If the RT cools to more than 3 °F lower than the ST for at least 2 minutes, then your appliance will automatically turn ON. The thermostat function will automatically adjust the flame height based on the difference between the RT and the ST. As the RT rises closer to the ST, the flame height will automatically adjust down. If the RT rises 2 °F above the ST for at least 2 minutes, then your appliance will automatically turn OFF.

During thermostat use, you will not be able to set your desired flame height level. Your appliance will automatically adjust flame height based on the difference between the RT and ST.

Flame Height

You can set your desired flame height level to affect the ambiance and control the heat output.

Your appliance will remember the previous flame height setting and adjust the flame to that level 10 seconds after start.

FUNCTIONS

Timer

For your convenience a timer can be set up to 180 minutes to turn off your appliance. The timer will turn the flame off automatically at the selected preset time.

To use the timer function, press “Timer” on the main screen, select time by using up and down arrows, then press “on”. To turn the timer off, select timer from main screen and select “off”.

Child Lock

A child lock is available underneath the battery cover. When the lock is enabled, the screen will lock and no functions can be selected.

Lights*

If your appliance is equipped with lighting features, use this function to adjust them to your desired intensity. The lights can be adjusted whether the flame is on or off.

Power Vent*

Power Vent technology makes it possible to install a gas appliance virtually anywhere. The Power Vent is a fan powered accessory that pulls exhaust from the appliance providing longer and more flexible venting configurations.

A Power Vent is a standard accessory on some products and an option on others. When a Power Vent is detected, a pre-purge of 120 seconds is automatically required. During this time, the power icon is temporarily replaced with 2MIN, 90s, 60s, and 30s, denoting the countdown until the appliance turns on. All other functions, except for TURN FLAME OFF are disabled during this time.

The Power Vent is always ON when the flame is ON.

When the flame is turned off, a post-purge time of approximately 20 minutes will occur.

Cold-climate function and battery backup are disabled if a Power Vent is used.

INDICATORS

Temperature Display

You can toggle the temperature display between °F and °C by tapping on the Room Temperature area.

HOT

This indicates that the appliance is still hot, even when the appliance is off.

Diagnostics Menu

Tap anywhere in the gray indicator bar area to display all functions below. When red, it indicates an error has been detected.

Cold Climate

This function turns on a small pilot flame and keeps the air inside your appliance warm while not in use. It is a useful feature in colder weather to minimize condensation on the appliance glass.

Note: This feature is disabled when a Power Vent is installed on the appliance.

RC Batt

Remote control battery life indicator. If the batteries on your remote are low, a notification will display on the screen asking you to ‘replace remote batteries’.

Backup Batt

The battery life indicator for a backup power source located inside your appliance. It is intended to operate the appliance in the event of a power failure. Consult your owner’s manual for your appliance on how to utilize this feature.

Batteries should only be used as an appliance power source in the event of a power outage. Batteries should not be used as a primary long-term power source.

Note: Battery backup is not available if a Power Vent is installed.

* = Optional Feature

INDICATORS

Pairing

The green icon indicates that the remote is paired to your appliance and can operate it. If the icon is gray, it is not paired. Please contact your dealer and report this issue.

Call Dealer - Pilot Flame Error

Your appliance has been disabled. Please contact your dealer and report this issue.

Call Dealer - Appliance Safely disabled

Your appliance has been disabled. Please contact your dealer and report this issue.

Call Dealer - Power Vent, Fan, Lights

Your appliance has detected that an accessory is not functional. Please contact your dealer to report this issue.

Remote Control Communication Error

Your remote control is not able to communicate with your appliance. Verify that you have power to your appliance. If there is a power outage, verify that appliance battery backup is fitted with new batteries. After taking these actions, communication can be re-established by pressing the screen to activate IFT-RC400. It may take several minutes for IFT-RC400 to re-establish pairing.

Replace Remote Batteries

Your remote batteries are low. Recommend immediate replacement before using remote to control appliance.

Maintenance

Your appliance will remind you to schedule routine service after 300 hours of Flame ON time is accumulated. When the message below appears on your IFT-RC400 remote display (with your dealer contact info if originally programmed into the IFT-RC400 at installation), please contact your dealer for a 300 hour inspection to ensure your appliance is operating at peak performance.

To reset the 300-hour maintenance reminder:

1. Wake-up your IFT-RC400 display by touching anywhere on the touch screen.
2. Turn the IFT-RC400 over and insert, press and hold a paperclip type object in the 'P' button hole for at least 10 seconds.
3. Double-beep from the IFT-RC400 will indicate that the IFT-RC400 will reset the 300-hour maintenance reminder.

If the RC400 300-hour maintenance message does not clear on the first try, repeat above steps.



This equipment complies with part 15 of FCC RF Rules. Operation is subject to the following two conditions:
1) This device may not cause interference and
2) This device may accept any interference, including interference that may cause undesired operation of the device.

