

This Owner's Manual is provided and hosted by [Appliance Factory Parts](#).



Monessen Hearth NB24NV Owner's Manual

[Shop genuine replacement parts for Monessen Hearth
NB24NV](#)



[Find Your Monessen Hearth Fireplace Parts - Select From 701 Models](#)

----- Manual continues below part list -----

Available Replacement Parts for Monessen Hearth NB24NV

SRV00F0540	Lava rock 2.5 pound bag
SRV00K0632	ASSY-WIRE
SRV14D0503	PIEZO IGNITER-snap in
SRV32D0232	SWITCH, ON/OFF+

Installation/Owner's Manual

Appliance Setup, Care and Operation

INSTALLER: Leave this manual with party responsible for use and operation.

OWNER: Retain this manual for future reference.

Contact your dealer with questions regarding installation, operation or service.

NOTICE: DO NOT discard this manual!



Natural Blaze Series

Models:

NB18NV/PV

NB24NV/PV

NB18NIF/PIF

NB24NIF/PIF

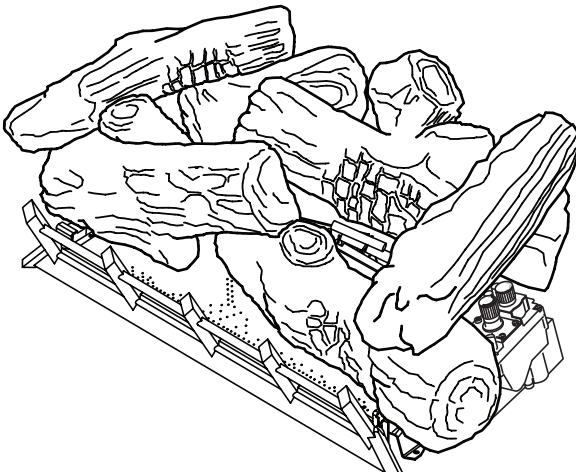

▲ WARNING:
FIRE OR EXPLOSION HAZARD
Failure to follow safety warnings exactly could result in serious injury, death, or property damage.

- **DO NOT** store or use gasoline or other flammable vapors and liquids in the vicinity of this or any other appliance.
- **What to do if you smell gas**
 - **DO NOT** try to light any appliance.
 - **DO NOT** touch any electrical switch. **DO NOT** use any phone in your building.
 - Leave the building immediately.
 - Immediately call your gas supplier from a neighbor's phone. Follow the gas supplier's instructions.
 - If you cannot reach your gas supplier, call the fire department.
- Installation and service must be performed by a qualified installer, service agency, or the gas supplier.

In the Commonwealth of Massachusetts installation must be performed by a licensed plumber or gas fitter. See appliance installation manual for additional Commonwealth of Massachusetts requirements.

- **DO NOT** install this unit in a bedroom or bathroom.

▲ Safety Alert Key:

- **DANGER!** Indicates a hazardous situation which, if not avoided will result in death or serious injury.
- **WARNING!** Indicates a hazardous situation which, if not avoided could result in death or serious injury.
- **CAUTION!** Indicates a hazardous situation which, if not avoided, could result in minor or moderate injury.
- **NOTICE:** Used to address practices not related to personal injury.

Table of Contents

Installation Standard Work Checklist	3
--	---

1 Product Specific & Important Safety Information

A. Appliance Certification	4
B. BTU Specifications	4
C. Gas Pressures	4
D. High Altitude Installations	4
E. Non-Combustible Materials Specification	4

2 Getting Started

A. Design and Installation Considerations	5
B. Tools and Supplies Needed	5
C. Inspect Appliance and Components	5
D. Check Parts	6
E. Installation Information	6
F. Adequate Combustion Ventilation Air	7

3 Clearances & Height Requirements

A. Clearances & Height Requirements	9
B. Before Installing the Appliance	13
C. Damper Stop Installation	13
D. Assembly Procedure	14

4 Gas Information

A. Gas Line Connection	15
B. Fuel Type	15
C. Gas Pressure	15
D. Gas Service Access	16
E. Check Gas Pressure	16

5 Electrical Information

A. General Information	17
B. Connect Optional Wall Switch or Thermostat	18
C. Connect Remote Receiver	19
D. Check System Operation	19
E. Wiring Requirements	20
F. Detailed Component Operating Instructions	21

6 Gas Log Set

A. Grate & Log Installation	22
B. Log Placement (Berkley Oak)	23
C. Log Placement (Highland Oak)	25
D. Log Placement (Stoney Creek)	26
E. Log Placement (Beachcomber)	28
F. Flame Appearance	29
G. Operating Instructions	29

7 Owner's Manual

A. Congratulations	31
B. Limited Lifetime Warranty	32

8 Product Specification Information

A. Application Certification	35
B. BTU Specifications	35

9 Important Safety & Operating Information

A. Appliance Safety	36
B. General Operating Parts	38
C. Fuel Specifications	38
D. Before Lighting Appliance	38

10 Lighting Instructions

A. Millivolt	39
B. IntelliFire Plus ODS (IFP)	42
C. Initial Use	44

11 IntelliFire Plus

A. RC300 Remote Control	45
-----------------------------------	----

12 Maintenance & Service

A. Maintenance: Frequency & Tasks	49
B. Maintenance Tasks: Qualified Service Technician	49
C. Burner Ignition & Operation	49
D. Cleaning & Servicing	50

13 Troubleshooting

A. Millivolt Control System	51
B. IntelliFire Plus ODS Ignition System	52

14 Service Parts & Accessories

A. Service Parts	54
B. Accessories	72
C. Contact Information	74

NOTE: Monessen vent free gas logs are hand painted for ultimate beauty and realism. As a result, some variation in color and shading will occur from set to set. This is intentional and designed to make each product unique, as found in nature.

Installation Standard Work Checklist

ATTENTION INSTALLER: Follow this Standard Work Checklist

This standard work checklist is to be used by the installer in conjunction with, not instead of, the instructions contained in this installation manual.

Customer: _____
Lot/Address: _____

Date Installed: _____
Location of Fireplace: _____

Model (circle one): NB18NV, NB18PV, NB18NIF, NB18PIF
NB24NV, NB24PV, NB24NIF, NB24PIF

Installer: _____
Dealer/Distributor Phone # _____
Serial #: _____



WARNING! Risk of Fire or Explosion! Failure to install appliance according to these instructions could lead to a fire or explosion.

Gas Log Install Sections 2 and 5

Verified that the chimney has been cleaned. (pg. 13)
Verified clearances to combustibles.
Gas Logs are leveled and secured.
See page 8 for adequate provisions for combustion and ventilation
air have been verified.

YES

IF NO, WHY?

Gas Section 4

Proper appliance for fuel type.
Leak check performed and inlet pressure verified.
Verified proper air shutter setting for installation type.

Electrical Section 5

Switch wires properly installed.

Embers & Logs Section 6

All packaging and protective materials removed (inside & outside of appliance).
Embers and logs installed correctly.
Accessories installed properly.

Finishing Section 3

Verified all clearances meet installation manual requirements.
Mantels and wall projections comply with installation manual requirements.

Manual bag and all of its contents are removed and the log set
given to party responsible for use and operation.
Started log set and verified no gas leaks exist.

Hearth & Home Technologies recommends the following:

- Photographing the installation and copying this checklist for your file.
- That this checklist remain visible at all times on the appliance until the installation is complete.

Comments: Further description of the issues, who is responsible (Installer/ Builder/ Other Trades, etc) and corrective action needed _____

Comments Communicated to party responsible _____ by _____ on _____
(Builder / Gen. Contractor/) (Installer) (Date)

➔ = Contains updated information.

1 Product Specific and Important Safety Information

A. Appliance Certification

MODEL: NB18NV/PV, NB24NV/PV, NB18NIF/PIF
NB24NIF/PIF
LABORATORY: CSA
TYPE: Unvented Room Heater
STANDARD: ANSI Z21.11.2-2016 (Unvented Heaters)
ANSI Z21.60-2017-CSA 2.26-2017 (Decorative Gas Appliances for Installation in Solid-Fuel Burning Fireplaces)

This product is listed to ANSI standards for "Unvented Room Heaters" and applicable sections of "Gas Burning Heating Appliances for Manufactured Homes" and "Gas Fired Appliances for Use at High Altitude."

NOTICE: This installation must conform with local codes. In the absence of local codes you must comply with the National Fuel Gas Code, ANSI Z223.1-latest edition in the U.S.A.

NOT INTENDED FOR USE AS A PRIMARY HEAT SOURCE.
This appliance is tested and approved as either supplemental room heater or as a decorative appliance. It should not be factored as primary heat in residential heating calculations.

B. BTU Specifications

Models		Maximum Input BTU/h	Minimum Input BTU/h	Orifice
NB18NV	(0-2000 FT)	28,000	19,000	#38
NB18PV	(0-2000 FT)	27,000	22,000	#52
NB24NV	(0-2000 FT)	37,000	25,000	3.00 mm
NB24PV	(0-2000 FT)	36,000	28,000	#49
NB18NIF	(0-2000 FT)	28,000	19,000	#38
NB18PIF	(0-2000 FT)	27,000	22,000	#52
NB24NIF	(0-2000 FT)	37,000	25,000	3.00 mm
NB24PIF	(0-2000 FT)	36,000	28,000	#49

NOTE: For LP models an external regulator is required to reduce supply pressure to a maximum of 13" w.c.

C. Gas Pressures

	NATURAL	PROPANE (LP)
Inlet Minimum	5.0" w.c.	11.0" w.c.
Inlet Maximum	10.5" w.c.	13.0" w.c.
Gas Valve Manifold Pressure Setting	3.5" w.c.	10" w.c.
Pilot Regulator	3.5" w.c.	—

NATURAL GAS: An external regulator is required to reduce supply pressure to a maximum of 10½" w.c. on natural gas systems operating at higher pressure.

PROPANE/LPG: An external regulator is required to reduce supply pressure to a maximum of 13" w.c.

Pilot/ODS

The gas log heater is fitted with a specially designed safety pilot (ODS assembly) which senses the amount of oxygen available in the room and shuts the gas log heater off if the oxygen level begins to drop below a satisfactory level. The pilot can only be relit when adequate fresh air is available.

D. High Altitude Installations

NOTICE: If the heating value of the gas has been reduced, these rules do not apply. Check with your local gas utility or authorities having jurisdiction.

When installing above 2000 feet elevation: Reduce input rate 4% for each 1000 feet above sea level.

Check with your local gas utility to determine proper orifice size.

E. Non-Combustible Materials Specification

Material which will not ignite and burn. Such materials are those consisting entirely of steel, iron, brick, tile, concrete, slate, glass or plasters, or any combination thereof.

Materials that are reported as passing **ASTM E 136, Standard Test Method for Behavior of Materials in a Vertical Tube Furnace at 750 °C** shall be considered non-combustible materials.

2 Getting Started

A. Design and Installation Considerations

Installation MUST comply with local, regional, state and national codes and regulations. Consult insurance carrier, local building inspector, fire officials or authorities having jurisdiction over restrictions, installation inspection and permits.

Before installing, determine the following:

- Where burner assembly and log set are to be installed.
- Gas supply piping.
- Whether optional accessories—devices such as a wall switch or remote control—are desired.
- Approved wood burning masonry fireplace or vent-free fireplace.



Installation and service of this appliance should be performed by qualified personnel. Hearth & Home Technologies recommends HHT Factory Trained or NFI certified professionals.



Improper installation, adjustment, alteration, service or maintenance can cause injury or property damage. For assistance or additional information, consult a qualified service technician, service agency or your dealer.

B. Tools and Supplies Needed

Before beginning the installation be sure that the following tools and building supplies are available.

- Tape measure
- Gloves
- Voltmeter
- Manometer
- Phillips screwdriver
- Safety glasses
- Flat blade screwdriver
- Soapy water solution for gas leak testing
- Electric drill and bits (1/4 in. magnetic)
- External regulator (for propane/LPG only & 1/2 psi Natural gas system)
- Piping which complies with local codes
- Pipe sealant approved for use with propane/LPG (Resistant to sulfur compounds)
- Manual shutoff valve
- Sediment trap
- Tee joint
- Pipe wrench

C. Inspect Appliance and Components

- Carefully remove the appliance and components from the packaging.
- Logs are packaged and sold separately.
- Report to your dealer any parts damaged in shipment.
- **Read all of the instructions before starting the installation. Follow these instructions carefully during the installation to ensure maximum safety and benefit.**

WARNING! Risk of Fire or Explosion! Damaged parts could impair safe operation. DO NOT install damaged, incomplete or substitute components. Keep appliance dry.

Hearth & Home Technologies disclaims any responsibility for, and the warranty will be voided by, the following actions:

- Installation and use of any damaged appliance.
 - Modification of the appliance.
 - Installation other than as instructed by Hearth & Home Technologies.
 - Installation and/or use of any component part not approved by Hearth & Home Technologies.

Any such action may cause a fire hazard.

WARNING! Risk of Fire, Explosion or Electric Shock! DO NOT use this appliance if any part has been under water. Call a qualified service technician to inspect the appliance and to replace any part of the control system and/or gas control which has been under water.

 **WARNING: This product and the fuels used to operate this product (liquid propane or natural gas), and the products of combustion of such fuels, can expose you to chemicals including benzene, which is known to the State of California to cause cancer and reproductive harm. For more information go to: www.P65Warnings.ca.gov.**

CAUTION Gloves are recommended when handling refractory and logs to prevent skin irritation from loose fibers. Logs are fragile; handle with care.

D. Check Parts

Verify contents to ensure you have received all parts. You should have the following:

NB Models

- Unvented gas log burner assembly
- Two (2) bags of crushed volcanic rock
- Installation/operating instructions
- Two (2) Anchoring Screws
- Ceramic fiber or refractory logs
- Rock wool
- Grate assembly
- On/off log switch assembly (MV models only)
- RC300 remote control (IFP models only)
- Double A batteries (IFP models only)

The following options may be used with the millivolt controlled heater. These options are *not* packaged with the log set.

- Hand-held remote with receiver (MV)
- Wall switch with 15' wire
- HILOKTN/P (an accessory kit for flame adjustment from a hand held remote)

Carefully inspect the contents for shipping damage. If any parts are missing or damaged, immediately inform the dealer from whom you purchased the appliance. **Do not attempt to install any part of the appliance unless you have all parts in good condition.**

E. Installation Information

⚠ WARNING

This appliance is for installation only in a solid-fuel burning masonry or UL127 factory-built fireplace or in listed ventless firebox enclosure. It has been design certified for these installations.

Exception: DO NOT install this appliance in a factory-built fireplace that includes instructions stating it has not been tested or should not be used with unvented gas logs.

Use manufacturer's installation and clearance requirements as defined in their manual.

The NB18, 24, 30 series unvented room heaters are approved for installation into the following unvented fireboxes: MCFU, LCFU, GCFU, GRUF, BUF and Exacta.

The Natural Blaze Series unvented room heaters may also be installed into a Ventless Firebox Enclosure for Gas Fired Decorative Type Unvented Room Heaters per ANSI Z21.91 (typically referred to as a "universal firebox"), as long as firebox hearth dimensions meet the minimum hearth dimensions shown below. See Figure 2.1.

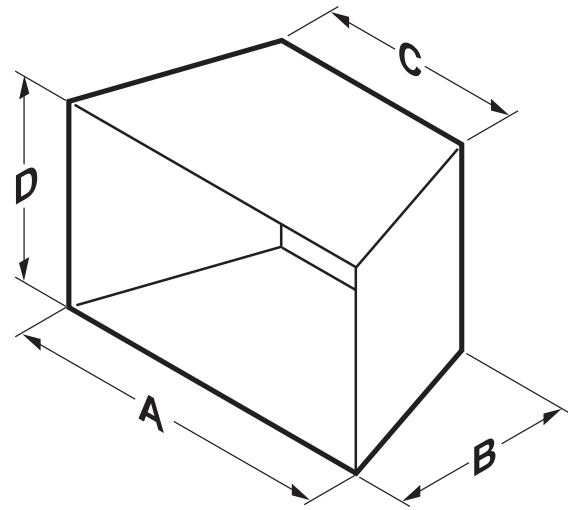

Model	A	B	C	D
NB18 w/18" Log	26"	13"	18"	17"
NB24 w/24" Log	29"	13"	22¼"	17"
NB24 w/30" Log	33"	13"	25¼"	17"
NB18IF w/18" Log	28½"	13"	20¼"	17"
NB24IF w/24" Log	31"	13"	25¼"	17"
NB24IF w/30" Log	35"	13"	25¼"	17"

Figure 2.1 - Minimum Dimensions for Engine, Logs & Firebox

Placement in Fireplace with a Restrictive Barrier

The following are guidelines for placing a gas log set in a fireplace that has a restrictive barrier on the fireplace for vented appliance only. See Figure 2.2.

Height of Restriction (x)	Minimum Depth of Fireplace/Firebox
No Restriction	13"
0" to 3"	16"
Greater than 3"	*

*Any barrier greater than 3" placed in front of the gas log set is not recommended by the manufacturer.

NOTE: Non-combustible material such as refractory brick may be used to line the floor of the fireplace in order to raise the height of the gas log set in relation to a restrictive barrier. If the unit is raised, the minimum height dimension listed in the homeowner's manual must be met or exceeded.

NOTE: If the log set is equipped with a remote receiver, a restrictive barrier may reduce the battery life by increasing the ambient temperature inside the fireplace. Placement of the receiver outside of the fireplace will extend the battery life.

⚠ WARNING

Barriers such as the bottom of a glass door frame placed in front of a gas log set can change the air flow characteristics of the fireplace which in turn can cause the unit to overheat and malfunction when installed as a vented log set.

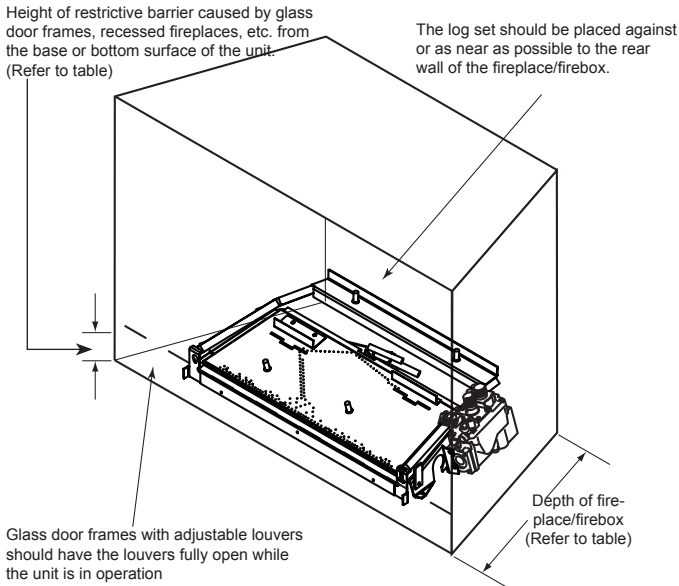

Figure 2.2 - Reference Drawing of a Natural Flame Log Set in an Enclosure with Glass Door or Barrier Installed

⚠ WARNING

Do not install the heater:

- Where curtains, furniture, clothing, or other flammable objects are less than 36" from the front of the heater.
- In high traffic areas.
- In windy or drafty areas.

⚠ WARNING

Gloves are recommended when handling logs to prevent skin irritation from loose fibers. Logs are fragile—handle with care.

F. Adequate Combustion Ventilation Air

This heater shall not be installed in a confined space or unusually tight construction unless provisions are provided for adequate combustion and ventilation air.

The National Fuel Gas Code, (ANSI Z223.1/NFPA54), defines a confined space as a space whose volume is less than 50 cubic feet per 1,000 BTU per hour (4.8m³ per kw) of the aggregate input rating of all appliances installed in that space, and an unconfined space as a space whose volume is not less than 50 cubic feet per 1,000 BTU per hour (4.8 m³ per kw) of the aggregate input rating of all appliances installed in that space. Rooms communicating directly with the space in which the appliances are installed, through openings not furnished with doors, are considered a part of a confined space.

Unusually tight construction is defined as construction where:

- Walls and ceilings exposed to the outside atmosphere have a continuous water vapor retarder with a rating of 1 perm (6 x 10⁻¹¹ kg per pa/sec-m²) or less with openings gasketed or sealed, and
- Weather stripping has been added to windows and doors, and
- Caulking or sealants are applied to areas such as joints around window and door frames, between sole plates and floors, between wall-ceiling joints, between wall panels, at penetrations for plumbing, electrical and gas lines and other openings.

The following formula can be used to determine the maximum heater rating per the definition of unconfined space: Refer to Figure 2.3.

$$\text{BTU/Hr} = \frac{(L_1 + L_2) \text{ Ft} \times (W) \text{ Ft} \times (H) \text{ Ft}}{50}$$

Consider two connecting rooms with an open area between, with the following dimensions:

$$L_1 = 15\frac{1}{2} \text{ Ft.}, L_2 = 12 \text{ Ft.}, W = 12 \text{ Ft.}, H = 8 \text{ Ft.}$$

$$\text{BTU/Hr} = \frac{(15\frac{1}{2} + 12) \times (12) \times (8)}{50}$$

If there were a door between the two rooms the calculation would be based only on the room with the heater.

$$\text{BTU/Hr} = \frac{(15\frac{1}{2}) \times (12) \times (8)}{50}$$

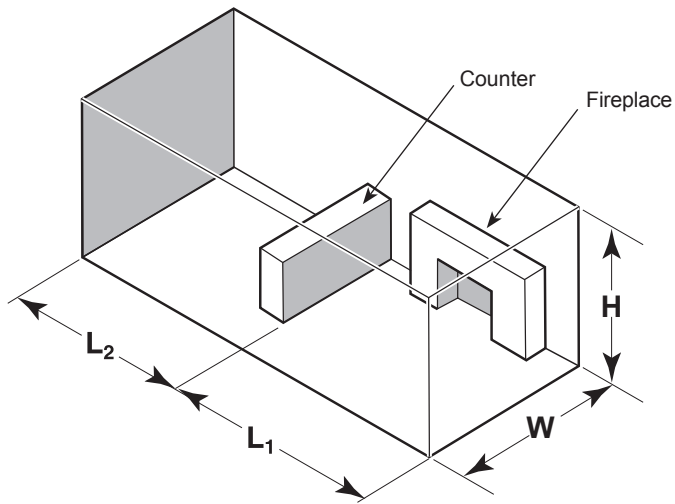

Figure 2.3

⚠ WARNING

If the area in which the heater may be operated does not meet the required volume for indoor combustion air, combustion and ventilation air shall be provided by one of the methods described in the *National Fuel Gas Code, ANSI Z223.1/NFPA 54*, the *International Fuel Gas Code* or applicable local codes.

3 Clearances and Height Requirements

A. Clearances and Height Requirements

⚠ WARNING

The dimensions shown in *Figures 3.1 through 3.8* and defined in the fireplace manufacturer's instructions are minimum clearances to maintain when installing this heater. Left and right clearances are determined when facing the front of the heater.

When heater is installed into a ventless firebox, minimum clearances, as specified by the ventless firebox manufacturer, must be met.

Follow these instructions carefully to ensure safe installation. Failure to follow instructions exactly can create a fire hazard.

Sidewall and ceiling clearances: The *sides* of the fireplace opening must be **at least 16"** from any combustible wall. The *ceiling* must be **at least 42"** from the top of the fireplace opening.

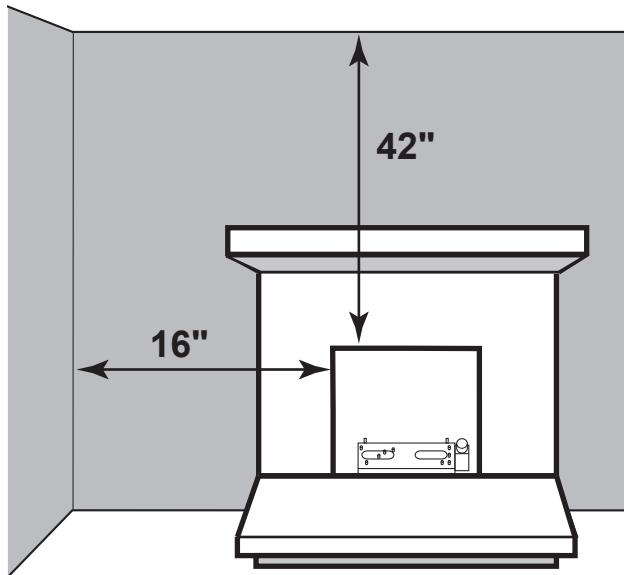

Figure 3.1 - Sidewall and Ceiling Clearances

Heat resistant material (minimum requirements) with no wooden mantel or other combustible projection:

To install the gas logs into a fireplace with no wooden mantel, shelf or other combustible projection above the fireplace opening, measure the heat resistant material height, according to *Figure 3.2* and **TABLE A**.

Heat resistant materials such as slate and marble must be **at least 1/2" thick**. Sheet metal should not be installed onto combustible material.

IMPORTANT: If you cannot meet these minimum clearances you must operate the heater with chimney flue damper open. Refer to "Installing Vented Applications" found on page 13.

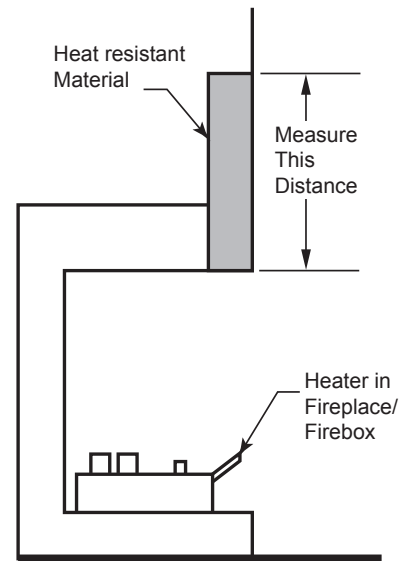

Figure 3.2 - Measure Heat Resistant Material

Table A — Heat Resistant Material Requirements with No Mantel or Combustible Projection

Heat Resistant Material Measurement	Requirements for Safe Installation	
	NB18	NB24
12" or more	Hood not required	Hood not required
8" or less than 12"	Hood not required	Extend heat resistant material to 12" or install hood. <i>Figure 3.3</i>
Less than 8"	Extend heat resistant material to 8" AND install hood. <i>Figure 3.3</i>	Extend heat resistant material to 8" AND install hood <i>Figure 3.5</i> . OR Extend heat resistant material to a height of at least 12".

Heat resistant material (minimum requirements) with wooden mantel or other combustible projection:

To install the heater with a wooden mantel, shelf or other combustible projection above, first measure the heat resistant material shown in *Figure 3.3*, then refer to Table B.

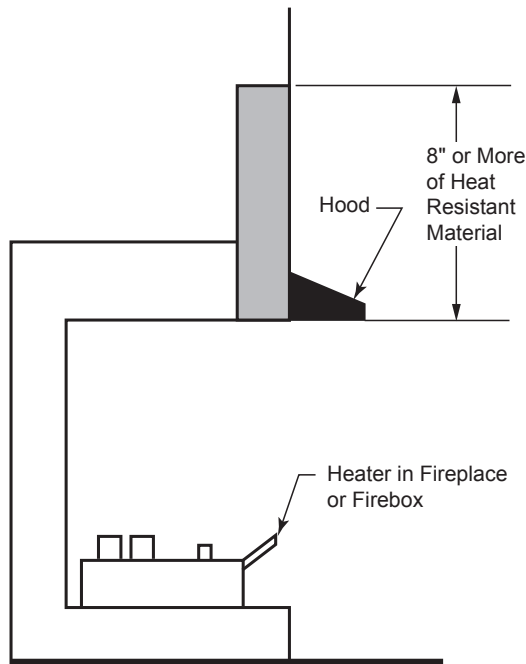

Figure 3.3 - Measuring Heat Resistant Material for Mantel

Table B - Heat Resistant Material Requirements Height and Mantel Location

Heat Resistant Material Measurement	Requirements for Safe Installation with Wooden Mantel, Shelf or other Combustible Projection	
	NB18	NB24
12" or more	Hood not required. Observe profiles (side elevations) shown in <i>Figure 3.6</i> .	Hood not required. Observe profile (side elevations) shown in <i>Figure 3.6</i> .
8" or less than 12"	Install hood and observe profiles shown in <i>Figure 3.5</i> OR Extend heat resistant material to at least 12" and observe profiles shown in <i>Figure 3.6</i> .	Install hood and observe profiles shown in <i>Figure 3.5</i> . OR Extend heat resistant material to at least 12" and observe profiles shown in <i>Figure 3.6</i> .
Less than 8"	Extend heat resistant to at least 8", install hood and observe profiles shown in <i>Figure 3.5</i> . OR Extend heat resistant material to at least 12" and observe profiles shown in <i>Figure 3.6</i> .	Extend heat resistant material to least 8", install hood and observe profiles shown in <i>Figure 3.5</i> . OR Extend heat resistant material to at least 12" and observe profiles shown in <i>Figure 3.6</i> .

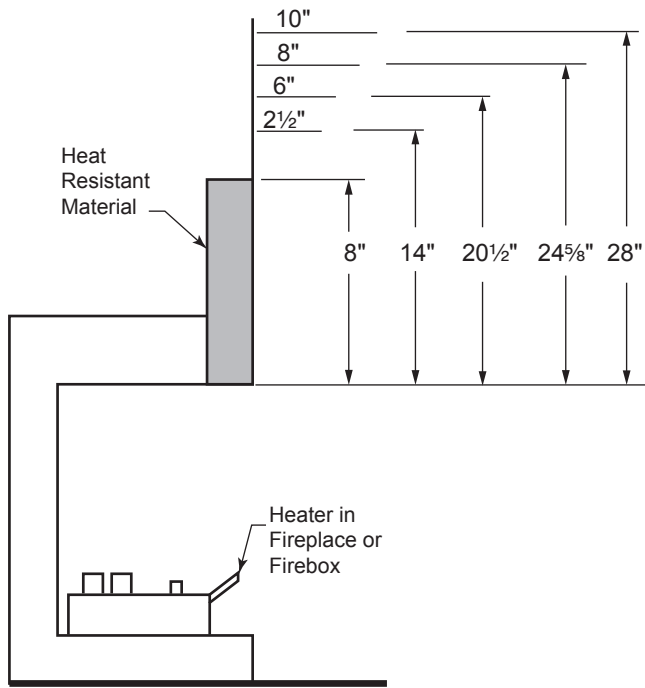

Figure 3.4 - Minimum Mantel Clearance with No Hood — NB18

Example: A mantel may project from the wall a maximum of 2½" at a minimum of 14" above the opening, and a maximum of 6" at a minimum of 20½" above the opening.

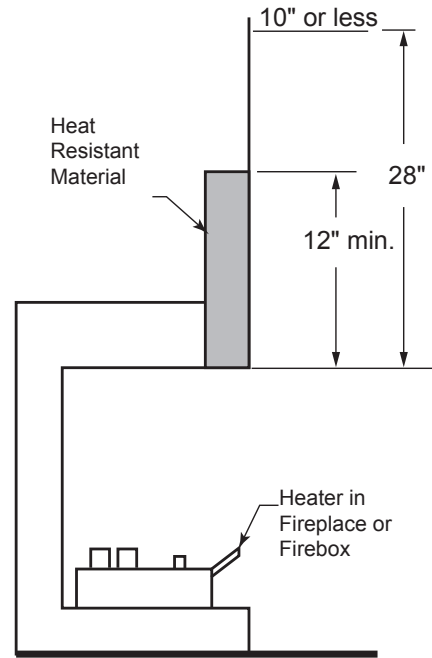

Figure 3.6 -Minimum Mantel Clearance with No Hood — NB18/24

Example: The bottom of the mantel may project from the wall a maximum of 10" at a minimum of 28" above the opening.

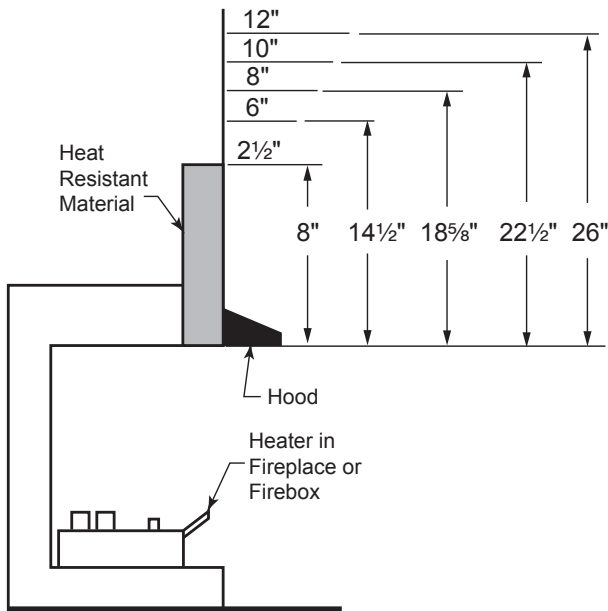

Figure 3.5 - Minimum Mantel Clearance with Hood — All Models

Example: A mantel may project from the wall a **maximum** of 2½" at a **minimum** of 8" above the opening, and a maximum of 6" at a **minimum** of 14½" above the opening.

The gas log heater must be installed at least 1 $\frac{3}{8}$ " above any combustible flooring material, such as carpeting or tile, which is closer than 14" to the base of the fireplace. The minimum distance must be maintained from the top surface of carpeting, tile, etc. *Figure 3.7*

OR

The gas log heater may be installed nearer to the floor if a minimum of 14" of noncombustible material such as slate or marble is installed between the base of the fireplace and the combustible flooring. *Figure 3.8*

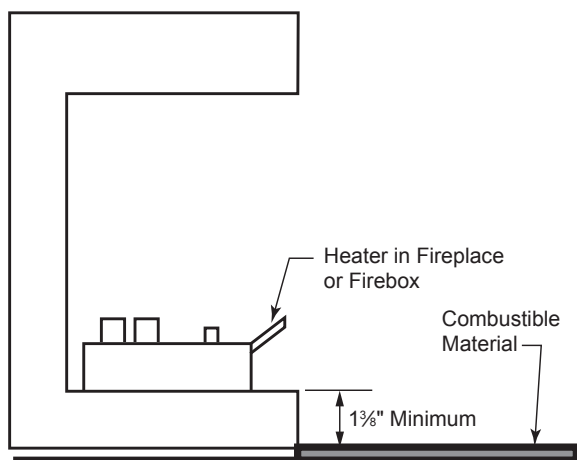

Figure 3.7 - Minimum Clearance above Combustible Flooring

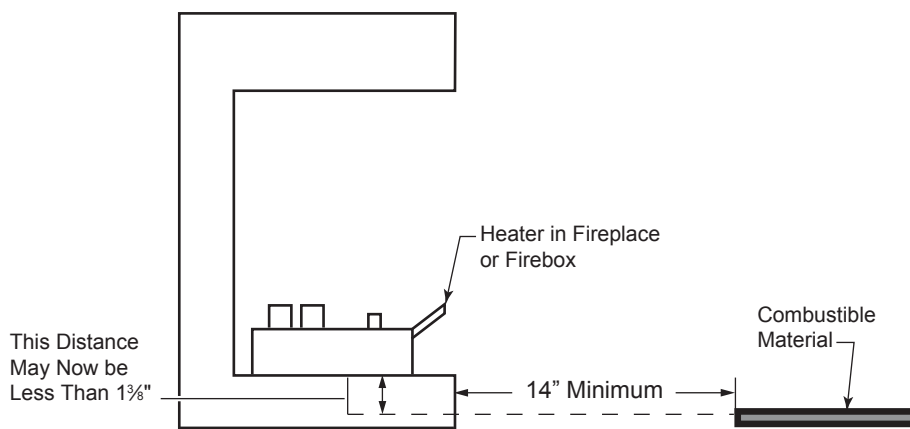

Figure 3.8 - Minimum Clearance above Combustible Flooring with Noncombustible Material Installed at Base of Fireplace

⚠ WARNING

Before installing in a solid fuel burning fireplace, The chimney flue and firebox must be cleaned of soot, creosote, ashes and loose paint by a qualified chimney cleaner.

⚠ WARNING

This log set can be installed in a solid fuel burning fireplace (masonry fireplace or manufactured fireplace) with a working flue and constructed of non combustible material or in a vent-free firebox.

Exception: DO NOT install this appliance in a factory-built fireplace that includes instructions stating that it has not been tested or should not be used with unvented gas logs. This log set may be installed as a vented log set.

⚠ WARNING

The use of thermostat is not allowed on vented log application. It is only allowed on unvented room heater classification.

Before Fully Installing the Unit:

- Turn **OFF** the gas supply to the fireplace or firebox.
- Seal any fresh air vents and/or ash clean-out doors located on the floor or wall of the fireplace. If left unsealed, drafting may cause pilot outage or sooting. Use a heat resistant sealant. **Do not seal the chimney flue damper.**

Vented Application Installations — NB & NBIF Only

Intellifire Plus ODS (IFP) and millivolt controlled gas logs may be installed as a vented decorative log set in compliance with ANSI Z21.60 and National Fuel Gas Code, Section 6.6. **Since, the gas logs are operated with the damper open, non-combustible material and minimum mantel requirements do not apply.**

NOTE: The use of a thermostat is prohibited in vented log installations.

B. Before installing the appliance:

- Turn off gas supply to fireplace or firebox.
- Have the fireplace floor and chimney professionally cleaned to remove ashes, soot, creosote or other obstructions. Have this cleaning performed annually after installation.
- Seal any fresh air vents or ash clean-out doors located on floor or wall of fireplace. If not, drafting may cause pilot outage or sooting. Use a heat-resistant sealant.

Install and operate the appliance as directed in this manual.

C. Damper stop installation:

A damper stop must be provided with the unit. Contact your dealer to obtain one. The damper stop must be installed as shown in *Figure 3.9* to prevent full closure of the fireplace damper blade and provide a minimum 29 square inch flue opening.

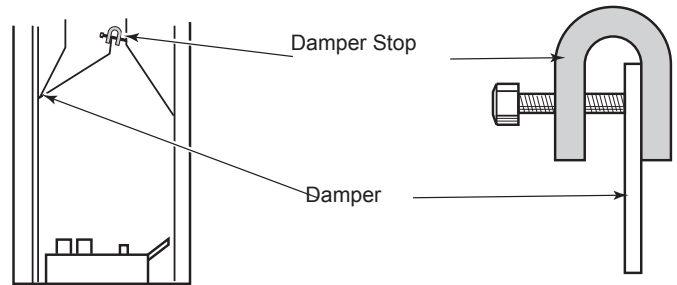

Figure 3.9 - Damper Stop Installation.

⚠ WARNING

When this log set is installed in a vented application, the damper must be clamped to be fully open.

D. Assembly Procedure

1. Center the burner assembly inside the fireplace or firebox. Make certain that the front of the burner assembly sits inside the front edge of the fireplace or the firebox.
2. Anchor holes are located on the right and left sides of the brackets attached to the engine base. After centering the burner assembly correctly, mark the holes on the fireplace or firebox floor. Drill two (2) 5/32" diameter holes approximately 1 1/4" deep. Anchor the two anchoring screws shipped with the unit using 1/4" hex head chuck and secure the burner assembly to the fireplace through the holes drilled earlier. See Figure 3.10.
3. Anchor the grate to the fireplace/firebox floor using the screws provided. See Figure 3.10.

Proper installation of the grate is essential to prevent any movement of the gas logs and controls during operation.

⚠ WARNING

You must secure the gas log heater to the fireplace floor. If not, the entire unit may move when you adjust the controls. Movement of unit may cause shifting of the gas logs which leads to sooting and improper burning. Grate movement could cause a gas leak.

Special care is required if you are installing the unit into a sunken fireplace. You must raise the fireplace floor to allow access to gas log controls. This will ensure adequate air flow and guard against sooting. Raise the fireplace floor using noncombustible materials, as described in Placement in a Fireplace with Restrictive Barrier on Page 6.

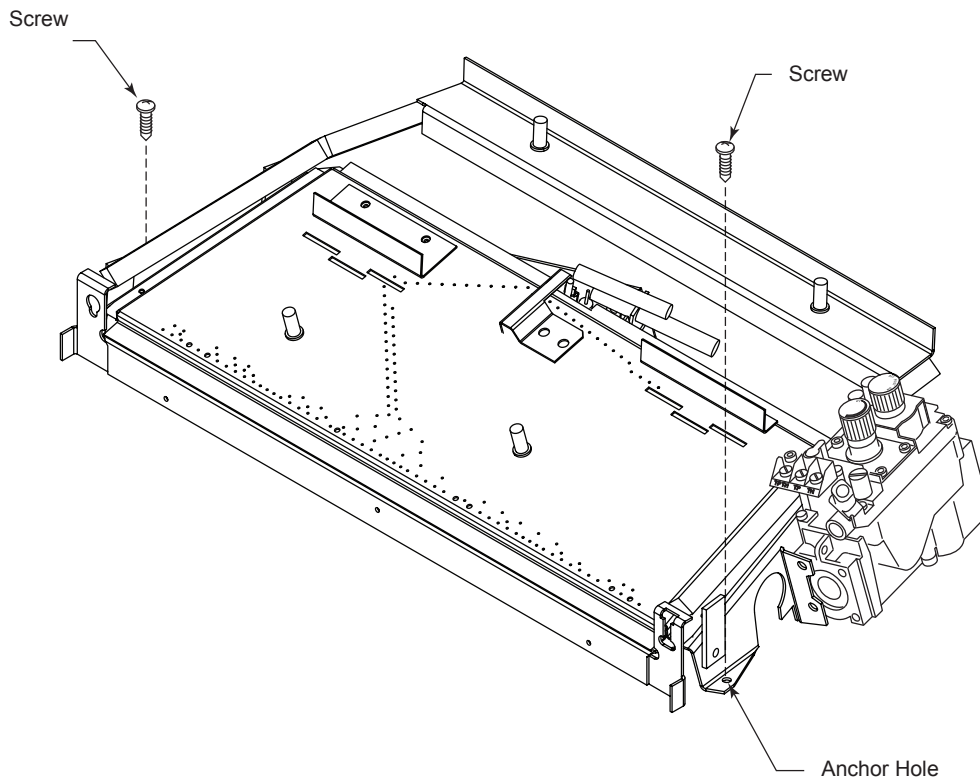

Figure 3.10 - Securing Heater to Floor of Fireplace/Firebox

4 Gas Information

⚠ WARNING

Use new black iron or steel pipe. Internally tinned copper or copper tubing can be used per National Fuel Code, section 2.6.3, providing gas meets hydrogen sulfide limits, and where permitted by local codes. Gas piping system must be sized to provide minimum inlet pressure (Listed on Data Plate) at the maximum flow rate (BTU/hr). Undue pressure loss will occur if the pipe is too small.

A manual shutoff valve must be installed upstream of the appliance. Union tee and plugged 1/8" NPT pressure tapping point should be installed upstream of the appliance.

A. Gas Line Connection

NOTICE: A qualified gas appliance installer must connect the heater to the gas supply. Consult all local codes.

IMPORTANT: Hold heater valve firmly with a wrench to prevent movement when connecting to inlet pipe.

Always use an external regulator for all propane/LPG heaters and high pressure one to two-pound systems only, to reduce the supply tank pressure to a maximum of 13" w.c. This is in addition to the internal regulator in the heater valve.

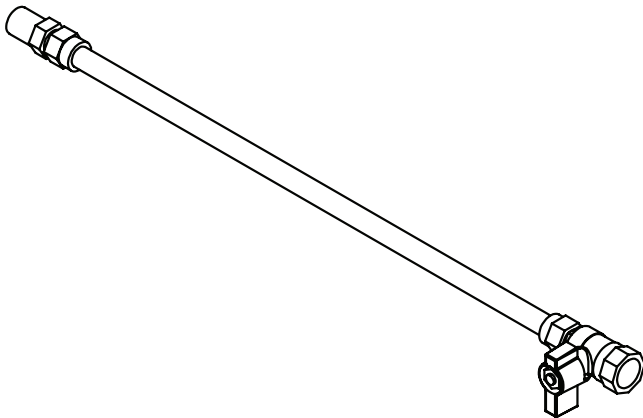

Figure 4.1 Gas Connection

⚠ WARNING

CHECK GAS TYPE: The gas supply must be the same as stated on the heater's rating plate. If the gas supply is different, **DO NOT INSTALL THE HEATER.** Contact your dealer for the correct model.

⚠ WARNING

Connecting directly to an unregulated propane/LPG tank can cause an explosion.

The heater gas inlet connection is a 3/8" NPT at the valve. On all control type units, the inlet connection is on the right side of unit. To connect from the opposite side, route the pipe around the back portion of the unit.

When tightening up the joint to the valve, hold the valve securely to prevent movement.

Test all gas joints from the gas meter to the heater valve for leaks using a gas analyzer or soap and water solution after completing connection. **DO NOT USE AN OPEN FLAME.**

Check the gas pressure with the appliance burning and the control set to **HIGH**.

B. Fuel Type

- This appliance is equipped for either natural or propane gas. **Field conversion is not permitted.**
- Make sure the appliance is compatible with available gas types.

C. Gas Pressure

- Optimum appliance performance requires proper input pressures.
- Gas line sizing requirements will be determined in ANSI Z223.1 National Fuel Gas Code in the USA.
- Pressure requirements are:

	NATURAL	PROPANE (LP)
Inlet Minimum	5.0" w.c.	11.0" w.c.
Inlet Maximum	10.5" w.c.	13.0" w.c.
Gas Valve Manifold Pressure Setting	3.5" w.c.	10" w.c.
Pilot Regulator	3.5" w.c.	—



WARNING! Risk of Fire or Explosion! High pressure will damage valve. Low pressure could cause explosion.

- Verify inlet pressures. Verify minimum pressures when other household gas appliances are operating.
- Install regulator upstream of valve if line pressure is greater than 1/2 psig.
- Valve pressure taps are accessible by removing the right side log. See Figure 4.2.

Note: Have the gas supply line installed in accordance with local codes, if any. If not, follow ANSI Z223.1. Installation should be done by a qualified installer approved and/or licensed as required by the locality. (In the Commonwealth of Massachusetts installation must be performed by a licensed plumber or gas fitter).

D. Gas Service Access

Depending upon local code, a manual gas shutoff, in a readily accessible area may be required and located upstream from the appliance.

⚠ WARNING	
 	<p>Fire Risk. Explosion Hazard. High pressure will damage valve.</p> <ul style="list-style-type: none"> • Disconnect gas supply piping BEFORE pressure testing gas line at test pressures above 1/2 psig. • Close the manual shutoff valve BEFORE pressure testing gas line at test pressures equal to or less than 1/2 psig.

E. Check Gas Pressure

Millivolt

The valve regulator controls the burner pressure which should be checked at the pressure test point.

Turn captured screw counter clockwise two or three turns and then place tubing to pressure gauge over test point (use test point "OUT" closest to control knob). After taking pressure reading, be sure and turn captured screw clockwise firmly to re-seal. Do no over torque. Check for gas leaks. See Figure 4.2.

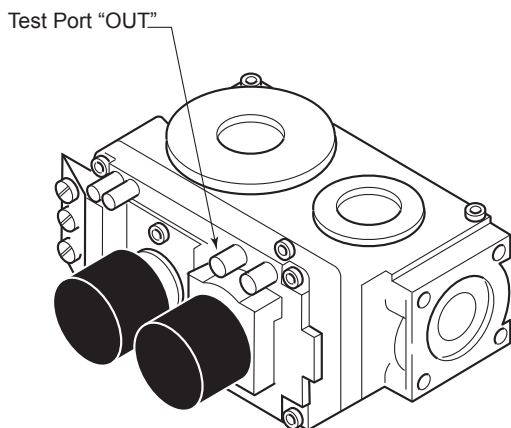

Figure 4.2 - Pressure Test Point Location Millivolt Control

Intellifire Plus ODS (IFP)

Check the gas pressure with the appliance burning and the control set to **HIGH**.

The valve regulator controls the burner pressure which should be checked at the pressure test point.

Turn captured screw counterclockwise two or three turns and then place tubing to pressure gauge over test point. Use test point "A" closest to gas inlet. After taking pressure reading, be sure and turn captured screw clockwise firmly to re-seal. Do not over torque. Check for gas leaks. See Figure 4.3.

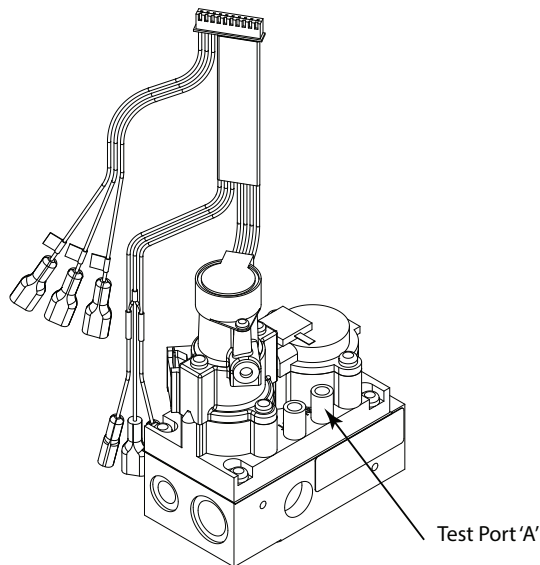

Figure 4.3 Pressure Test Point Location

5 Electrical Information

A. General Information

WARNING! Risk of Shock or Explosion! DO NOT wire 110-120 VAC to the valve or to the appliance wall switch. Incorrect wiring will damage controls.

NOTICE: This appliance must be electrically wired and grounded in accordance with local codes or, in the absence of local codes, with **National Electric Code ANSI/NFPA 70-latest edition**.

- Wire the appliance junction box to unswitched 110-120 VAC. This is required for proper operation of the appliance.
- A 110-120 VAC circuit for this product must be protected with ground-fault circuit-interrupter protection, in compliance with the applicable electrical codes, when it is installed in locations such as in bathrooms or near sinks.
- Low voltage and 110/120 VAC voltage cannot be shared within the same wall box.

Electrical Service and Repair

WARNING! Risk of Shock! Label all wires prior to disconnection when servicing controls. Wiring errors can cause improper and dangerous operation. Verify proper operation after servicing.

WARNING! Risk of Shock! Replace damaged wire with type 105° C rated wire. Wire must have high temperature insulation.

Accessories Requirements

- This appliance may be used with a wall switch, or optional wall mounted thermostat and/or a remote control.

Wiring for optional Hearth & Home Technologies approved accessories should be done now to avoid reconstruction. Follow instructions that come with those accessories.

CAUTION

Label all wires before disconnecting when servicing controls. Wiring errors can cause improper and dangerous operation.

WARNING

Do not connect wall switch to 110 V circuit.

WARNING

Electrical connections should only be performed by a qualified, licensed electrician. Main power must be off when connecting to main electrical power supply or performing service. All wiring shall be in compliance with all local, city and state codes. The appliance, when installed, must be electrically grounded in accordance with local codes or in the absence of local codes, with the National Electrical Code ANSI/NFPA 70 (latest edition) and Canadian Electrical Code, CSA C22.1.

CAUTION

Label all wires prior to disconnection when servicing controls. Wiring errors can cause improper and dangerous operation. Verify proper operation after servicing.

B. Connect Optional Wall Switch or Thermostat (vent free application only)

1. Use 18 awg, two-wire cable, 15 feet maximum length.
2. At one end of the cable, connect both wires to the wall switch or thermostat. At the other end, connect one wire to TP/TH and one wire to TH, using fork terminal or connect the wall switch/thermostat to the two male (0.25") terminals on the left side of the unit. The color of the wires does not matter.

The millivolt valve is a self-powered combination gas control **THAT DOES NOT REQUIRE 110 VAC TO OPERATE.**

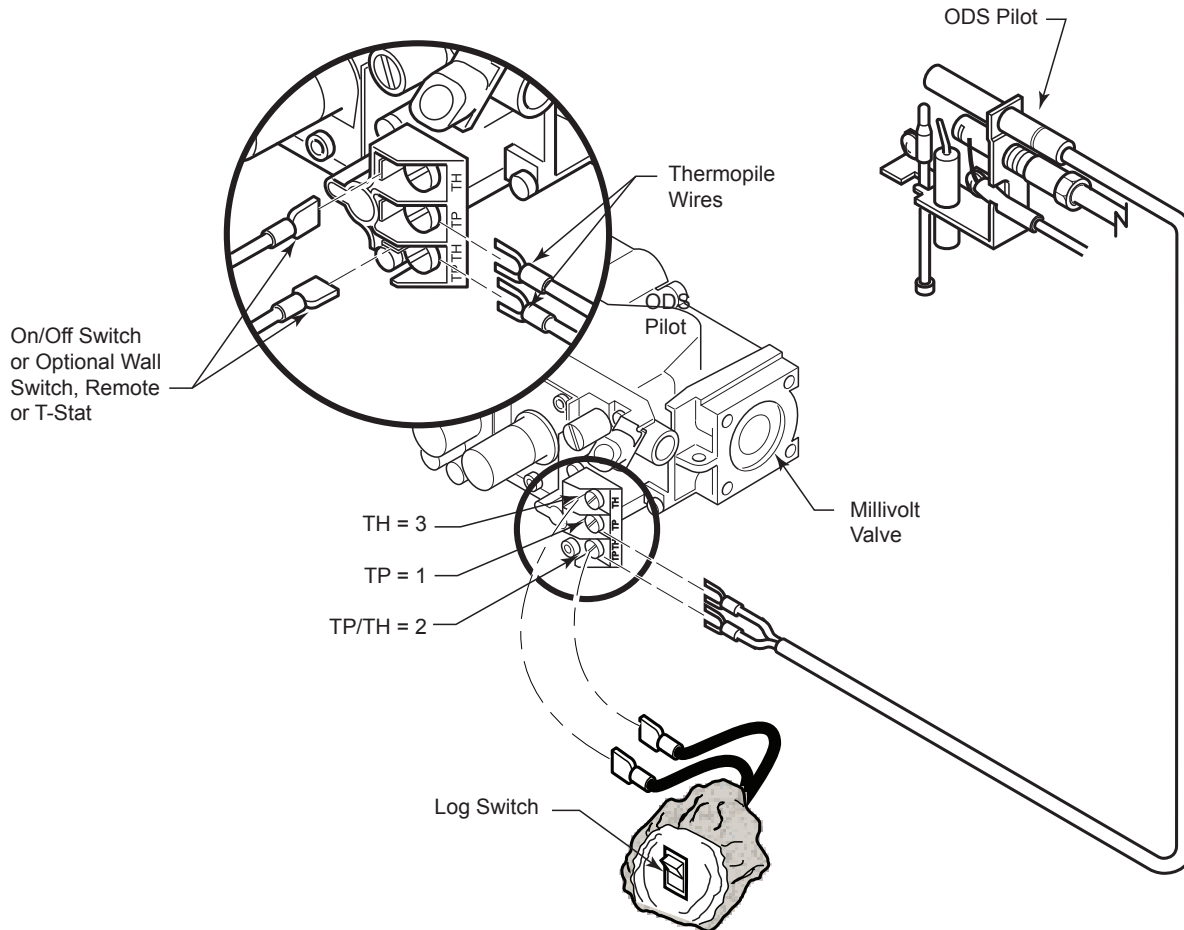

Figure 5.1 - Wiring Diagram

NOTE: Log switch wires are not factory connected. Connect log switch wires to the TP/TH and TH valve terminals as shown.

C. Connect Remote Receiver

1. Set remote receiver. See instructions included in receiver kit.
2. Unplug the two terminals for the log switch from the valve, connect the piggy back terminal of the receiver to the TH and TP/TH on the valve. Slide the terminal of the log switch onto the piggy back terminal on the receiver

NOTE: Do not allow wires to touch grate or burner.

NOTE: Heat reduces battery life. You can protect the receiver and extend battery life by mounting receiver in wall or other location outside the fireplace.

D. Check System Operation

The millivolt system and individual components may be checked with a millivolt meter having a 0-1000 mV range. Conduct each check shown in chart below by connecting meter test leads to terminals as indicated.

1. Complete Millivolt System Check

(“A” Reading - Thermostat contacts CLOSED - Control Knob “ON” - Main burner should turn ON)

- a. If the reading is more than 175 millivolts and the automatic valve still does not come on, replace the control.
- b. If the closed circuit reading (“A” reading) is less than 175 millivolts, determine cause for low reading, proceed to Section B below.

2. Thermopile Output Reading Check

(“B” Reading - Thermostat contacts OPEN - Main burner OFF)

1. Check gas pressure to the unit. If gas pressure is within minimum and maximum on data plate, then check pilot voltage, 500 millivolts minimum. If the minimum millivolt reading is not obtainable, replace pilot.

Check Test	To Test	Connect Meter Leads to Terminals	Switch or Thermostat Contacts	Meter Should Read
A	Complete System	2 and 3	Closed	Minimum 175
B	Thermopile Output	1 and 2	Open	Minimum 500

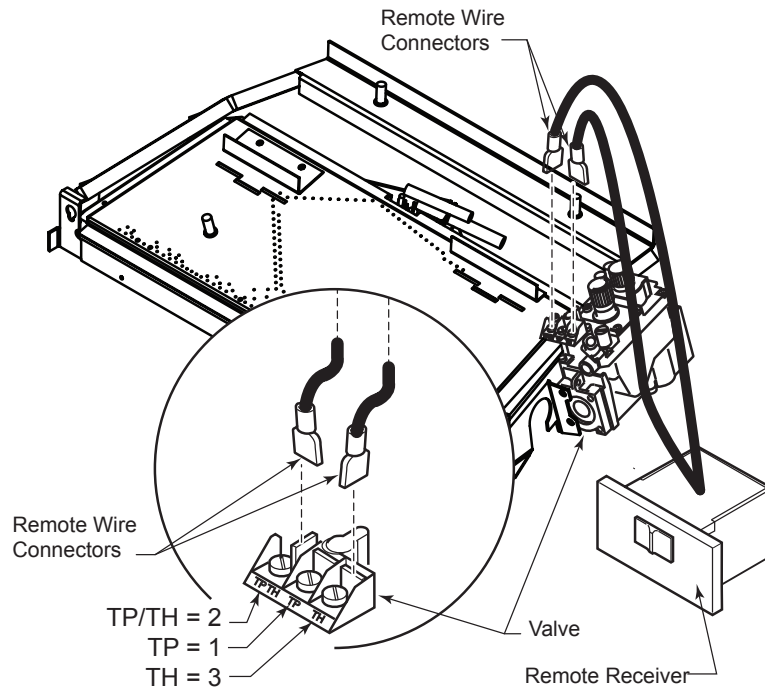

Figure 5.2 - Installing Remote Receiver

E. Wiring Requirements

Intellifire™ Plus ODS Ignition System Wiring

- Wire the appliance junction box to 110-120 VAC for proper operation of the appliance.

WARNING! Risk of Shock or Explosion! DO NOT wire IFP ODS controlled appliance junction box to a switched circuit. Incorrect wiring will override IFP ODS safety lock-out.

- Refer to Figure 5.4, IFP ODS Wiring Diagram.
- This appliance is equipped with an Intellifire™ Plus control valve which operates on a 6 volt/1.5 AMP system.
- Install 4 AA cell batteries into the battery pack before use. See Figure 5.3

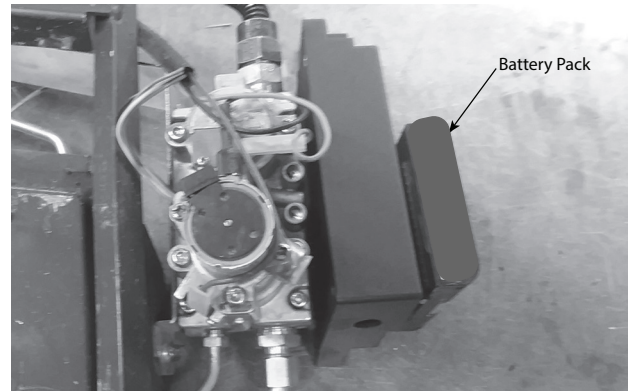

Figure 5.3 Battery Pack Location

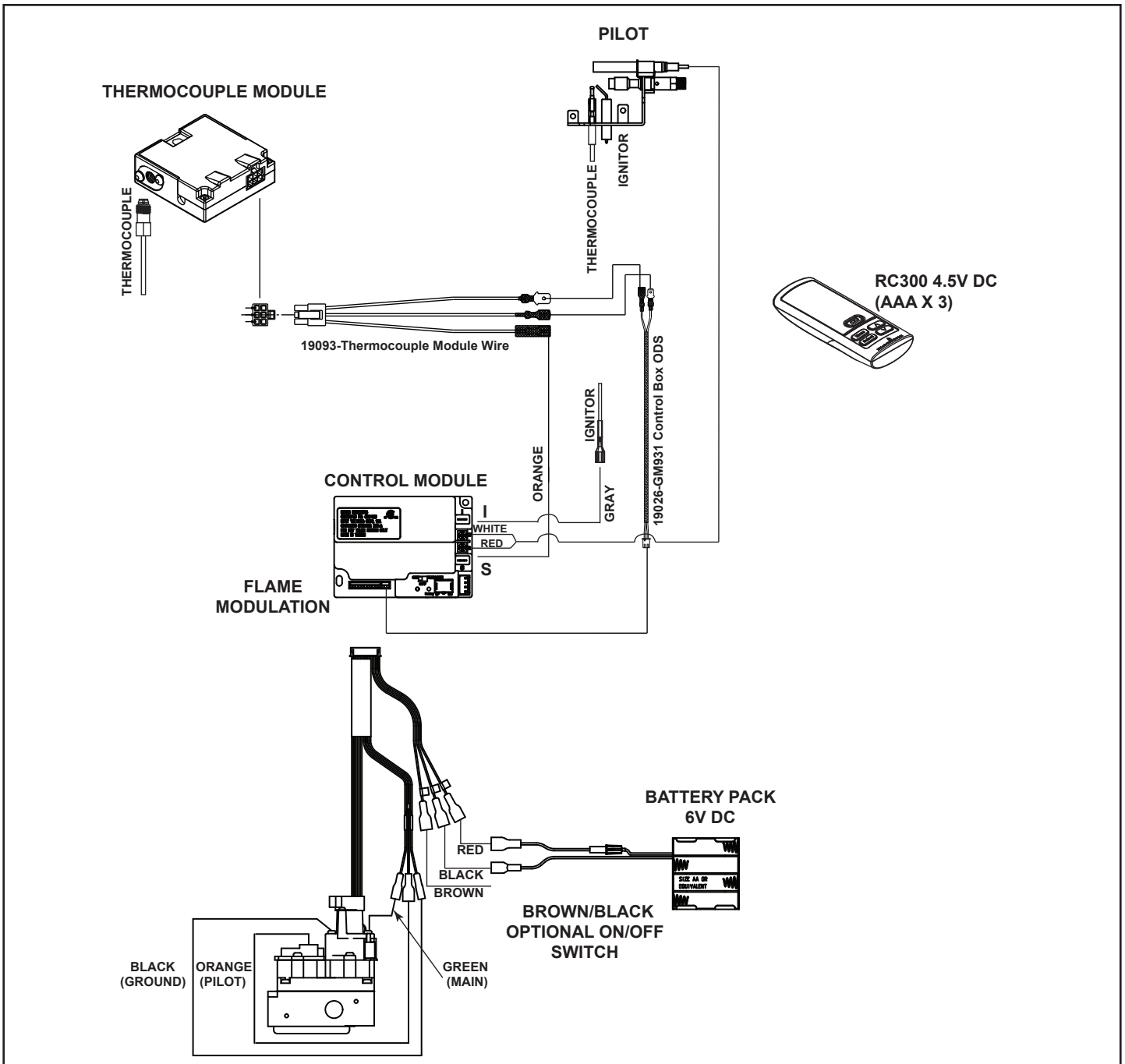

Figure 5.4 Intellifire™ Plus ODS Wiring Diagram (Battery Only)

F. Detailed Component Operating Instructions— Intellifire™ Plus ODS (Battery Only)

Control Module Operation

1. The control module has an ON/OFF/REMOTE selector switch that must be set. See Figure 5.5.

OFF Position: Appliance will ignore all power inputs and will not respond to any commands from a wall switch or remote. The unit should be in the OFF position during installation, service, battery installation, fuel conversion, and in the event that the control goes into LOCK-OUT mode as a result of an error code.

ON Position: Appliance will ignite and run continuously in the HI flame setting, with no adjustment in flame output. This mode of operation is primarily used for initial installation.

REMOTE Position: Appliance will initiate commands from an optional wired wall switch and/or the wireless remote (RC300).

2. If using a wired wall switch with the module in REMOTE mode, the appliance will ignite and run continuously in the HI flame setting, with no adjustment in flame output.
3. The control module has safety feature that automatically shuts down the heater after 9 hours of continuous operation without receiving a command from the RC300 remote.
4. If you intend to use both an optional wired wall switch and the RC300 remote control to operate your fireplace, the wall switch will override any commands given by the remote.
5. Battery life will be shortened if the flame adjustment feature is used frequently on the RC300 remote control.
6. **Module Reset**

This module may lock-out under certain conditions. When this occurs, the appliance will not ignite or respond to commands. The module will go into lock-out mode by emitting three audible beeps, then continuously displaying a RED/GREEN error code at its status indicator LED.

- Locate the module selector switch. (See Figure 5.5).
- Set the module selector switch to the OFF position.
- Wait five (5) minutes to allow possible accumulated gas to clear.
- Set the module selector switch to ON or REMOTE position.
- Start the appliance.

WARNING! Risk of Explosion! DO NOT press the module reset switch more than one time within a five minute time period. Gas could accumulate in firebox. Call a qualified service technician.

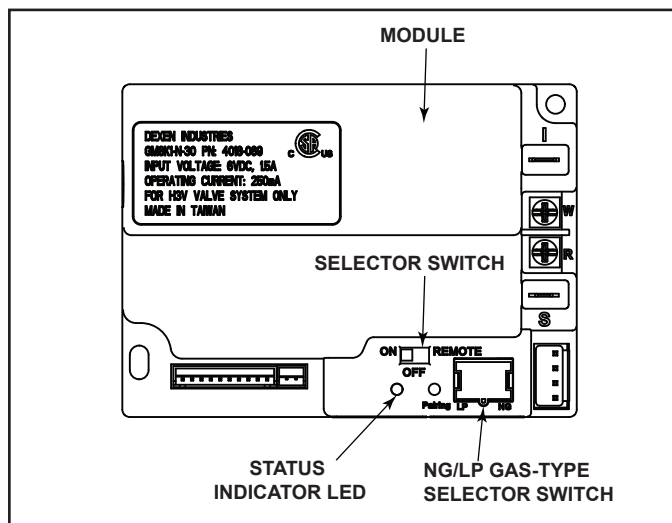

Figure 5.5 Control Module

Nine Hour Safety Shutdown Feature

The appliance has a safety feature that automatically shuts down the heater after nine hours of continuous operation without receiving a command from the wall switch or optional remote.

Appliance ON/OFF

Use the IntelliFire™ Plus Remote Control to control the ON/OFF function of the appliance. Follow instructions included with the remote control. If desired, a wall switch may be installed to control the ON/OFF function of the appliance.

6 Gas Log Sets

A. Grate and Log Installation

⚠ WARNING

The positioning of the logs is critical to the safe and clean operation of this heater. Sooting and other problems may result if the logs are not properly and firmly positioned in the appliance. Never add additional logs or embellishments such as pine cones, vermiculite or rock wool to the heater. Only use the logs and rock wool supplied with the unit.

Failure to position the parts in accordance with diagrams below or to use only parts specifically approved for this heater may result in property damage or personal injury.

BEFORE YOU BEGIN

This unit is supplied with ceramic fiber logs. Do not handle these logs with your bare hands. **Always wear gloves to prevent skin irritation from ceramic fibers.** After handling the logs, wash your hands gently with soap and water to remove any traces of fibers.

CAST IRON GRATE INSTALLATION

Install the cast iron grate by inserting screw head on back of right side of grate into the “I” shaped slot on front right corner of unit. After moving screw head to the bottom of the “I” slot, insert the screw head on the back of the left side of grate into the keyhole slot on the left front of unit. See Figure 6.1.

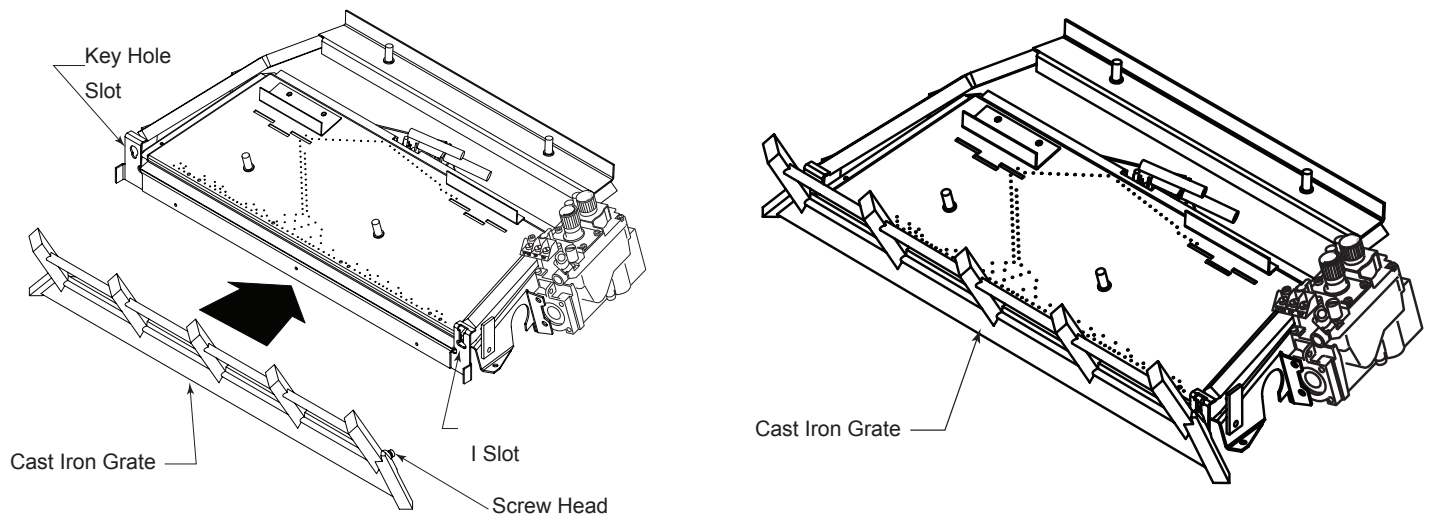

Figure 6.1 - Grate Installation

⚠ WARNING

- **Gloves are recommended when handling logs to prevent skin irritation from loose fibers. Logs are fragile - handle with care.**
- **Use only rock wool provided with log set.**
- **DO NOT ADD ADDITIONAL ROCK WOOL.**

Wash hands after placing rock wool. Itching may occur.

NOTE: Installation instructions are the same for 18", 24" and 30" log sets. Pictures used in this instruction illustrate the 24" set. Some variation may exist between the images and the set included with the instructions.

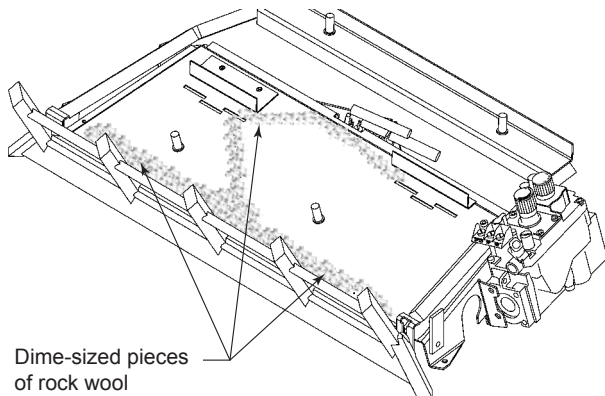

Figure 6.2 - Rock Wool Placement

B. INSTALL 18", 24" AND 30" (F, R) BERKLEY OAK LOGS PLACEMENT

1. Place the #1 log (the "chunk") on the grate bar right side of the burner adjacent to the controls. See Figure 6.3 .
2. Place front right log (#2) on right pin located on burner and right grate bar. See Figure 6.4. Slide Log #1 forward so that it is tight against log #2.

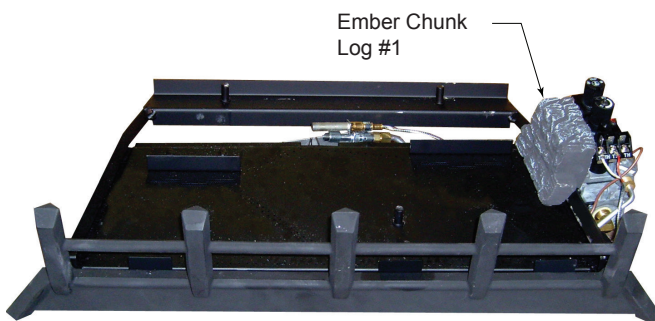

Figure 6.3 - Log #1 Placement

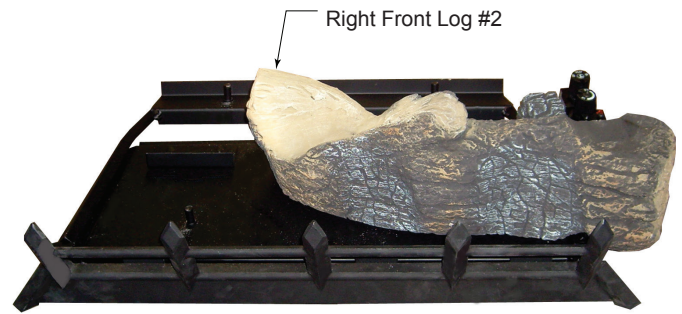

Figure 6.4 - Log #2 Placement

3. Place right rear log (#3) on pin located on rear support bracket and rest left side of log on front right log. See Figure 6.5.

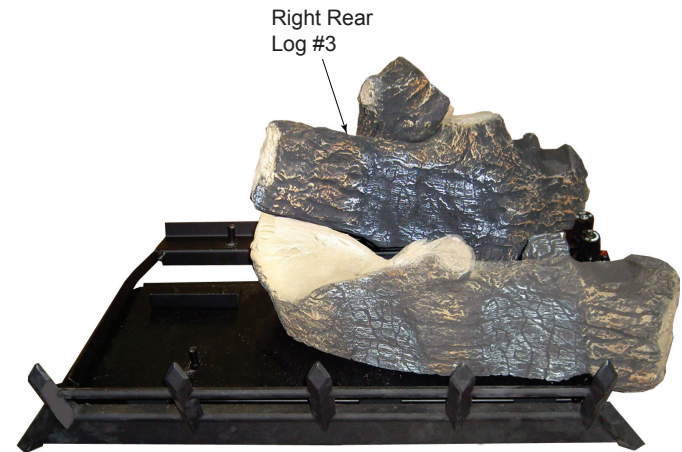

Figure 6.5 - Log #3 Placement

4. Place left rear log (#4) on pin located on rear support bracket on left side. See Figure 6.6.

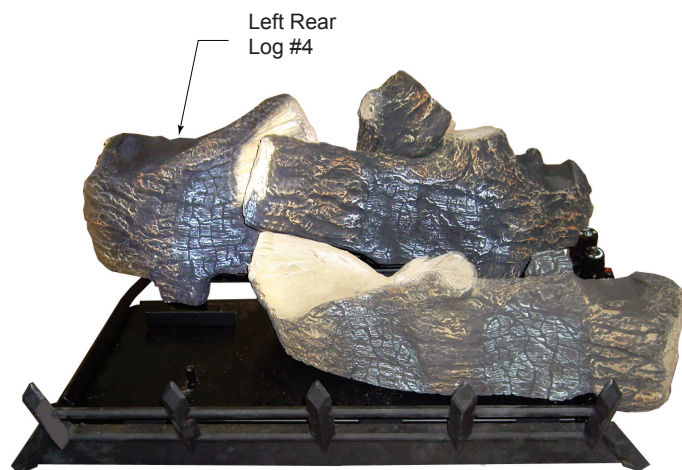

Figure 6.6 - Log #4 Placement

- Place left front log (#5) on left pin located on burner and left grate bar. Rest top right portion of log on right front log. See Figure 6.7.



Figure 6.7 - Log #5 Placement

- Place top left log (#6) on unit by placing grooved portion of log onto left grate bar with bark facing outward. Rest front part of log in groove on left front log. See Figure 6.8.



Figure 6.8 - Log #6 Placement

- Place left top log (#7) on left rear log (#4) and left front log (#5) using locating grooves on bottom of #7 and locating blocks on logs #4 and #5. See Figure 6.9.



Figure 6.9 - Log #7 Placement

- Place right top log (#8) onto right rear (#3) and right front (#2) logs using locator on bottom of right top log. See Figure 6.10.

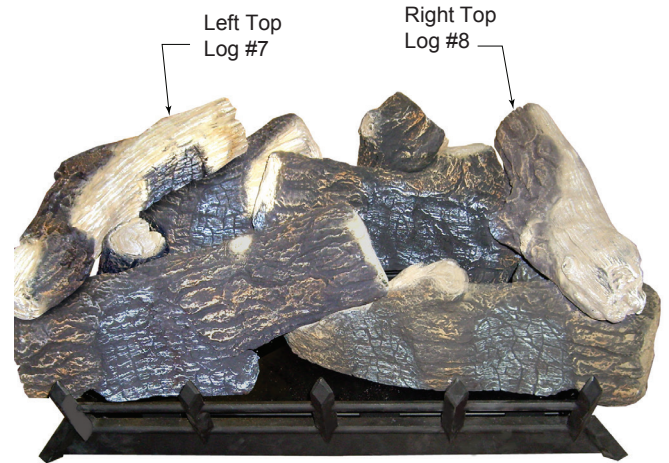

Figure 6.10 - Log #8 Placement

PLACE THE DECORATIVE ROCK

Optional volcanic rock may be placed around the unit on the floor of the firebox. Be sure to avoid any areas on the burner itself.

CAUTION	<p>DO NOT sprinkle volcanic rock on the logs, around the pilot, or on or near burners. This may cause sooting. Place volcanic rock only on the floor of the fireplace.</p> <p>During initial operation of the new heater, new burning logs and/or rock wool will give off a paper burning smell and orange flames will be present. Simply open the windows for a few hours to vent the odor.</p>
----------------	---

C. INSTALL 18", 24" AND 30" (F,R) HIGHLAND OAK LOGS PLACEMENT

1. Place the #1 log (the "chunk") on the grate bar right side of the burner adjacent to the controls. See Figure 6.11.

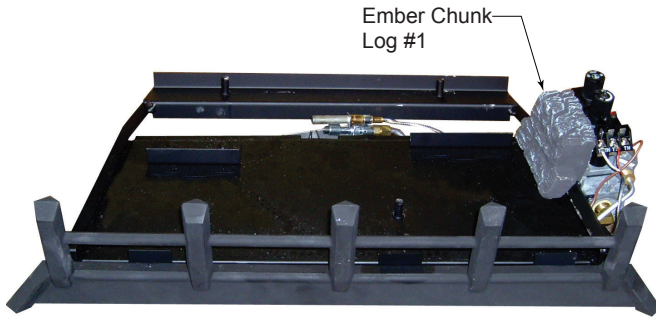

Figure 6.11 - Log #1 Placement

2. Place front right log (#2) on right pin located on burner and right grate bar. See Figure 6.12. After placing front right log, ensure log is fully upright and tilting towards the back of the burner.

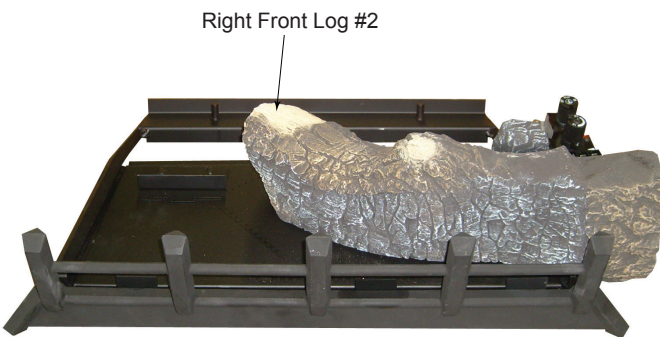

Figure 6.12 - Log #2 Placement

3. Place right rear log (#3) on pin located on rear support bracket and rest left side of log on front right log. See Figure 6.13. After placing right rear log, ensure log is fully upright and does not tilt forward. Slide #1 log ember chunk back to contact right rear log.



Figure 6.13 - Log #3 Placement

4. Place left rear log (#4) on pin located on rear support bracket on left side and left grate bar. See Figure 6.14.



Figure 6.14 - Log #4 Placement

5. Place left front log (#5) on left pin located on burner and left grate bar. Rest top right portion of log on right front log. See Figure 6.15.



Figure 6.15 - Log #5 Placement

6. Place top left log (#6) on left rear log (#4) and left front log (#5) using locating grooves on bottom of #6 and locating blocks on logs #4 and #5. See Figure 5.15.
7. Place right top log (#7) on right rear log (#3) and right front log (#2) using locators on the bottom of log #7 and locators on logs #2 and #3. See Figure 6.16.

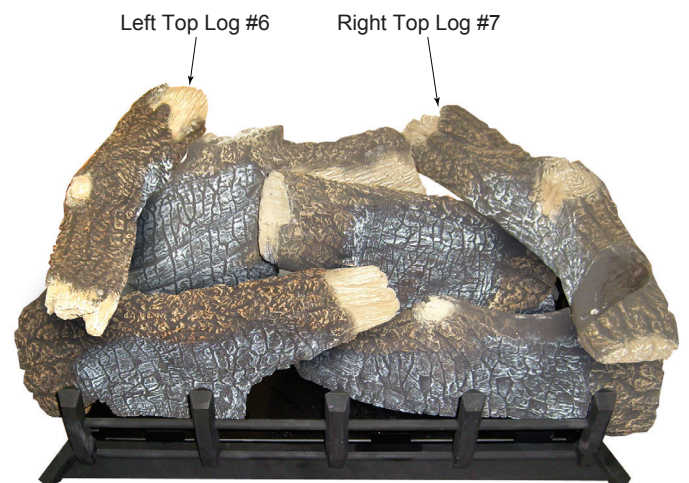

Figure 6.16 - Log #6 & #7 Placement

- Place small right front top log (#8) on log #7 and log #2 using locating grooves on the bottom of log #8 and locating blocks on log #7 and log #2. See Figure 6.17.



Figure 6.17 - Log #8 Placement

PLACE THE DECORATIVE ROCK

Optional volcanic rock may be placed around the unit on the floor of the firebox. Be sure to avoid any areas on the burner itself.

CAUTION

DO NOT sprinkle volcanic rock on the logs, around the pilot, or on or near burners. This may cause sooting. Place volcanic rock only on the floor of the fireplace.

During initial operation of the new heater, new burning logs and/or rock wool will give off a paper burning smell and orange flames will be present. Simply open the windows for a few hours to vent the odor.

D. STONY CREEK SC18/24/30-R LOGS PLACEMENT

- Place bottom log (#1) on two (2) pins on rear of grate assembly and push towards rear as far as possible. See Figure 6.18.

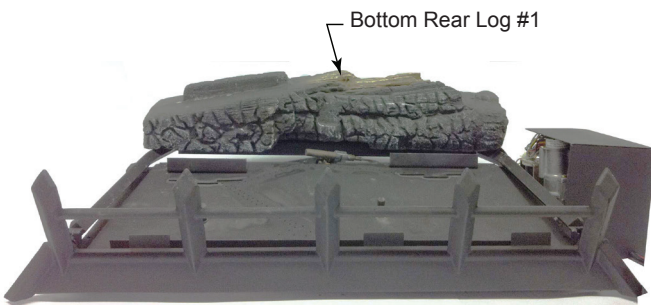

Figure 6.18 - Log #1 Placement

- Place the ember chunk (#2) with notch on both ends on the grate bar right side of the burner adjacent to the controls. Push towards rear as far as possible. See Figure 6.19.
- Place the ember chunk (#3) with notch on one end on the grate bar left side of the burner with notch towards rear. Push towards rear as far as possible. See Figure 6.19.

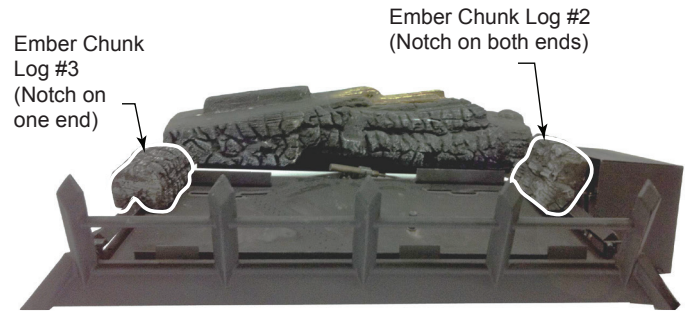

Figure 6.19 - Log #2 & #3 Placement

- Place front bottom right log (#4) on right pin located on burner and right grate bar. Figure 6.20.

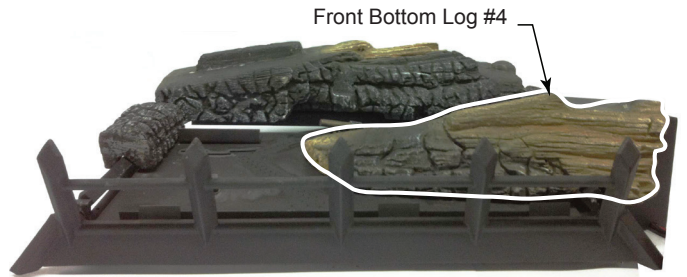

Figure 6.20 - Log #4 Placement

- Place front bottom left log (#5) on left pin located on burner and left grate bar. The right side of the log should rest on log #4. See Figure 5.20.
- Place mid right log (#6) on bottom rear log (#1) and front bottom right log (#4) by placing notch on bottom of log on locating block on log #1. Place front of log in notch of log #4. See Figure 6.21.

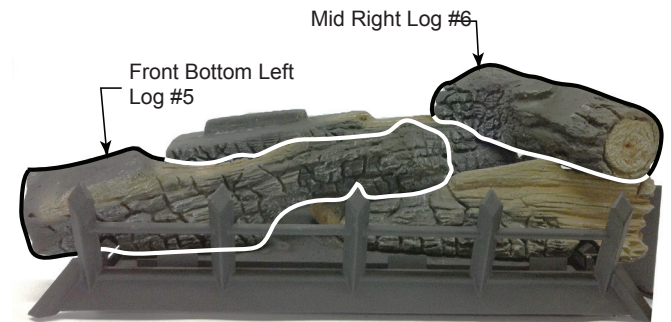

Figure 6.21 - Log #5 & #6 Placement

- Place mid rear log (#7) on bottom rear log (#1) and mid right log (#6) by placing notch on bottom of log onto locating block on log #1. Right side of log will rest on log #6. See Figure 6.22.



Figure 6.22 - Log #7 Placement

- Place mid left log (#8) on mid rear log (#7) and front bottom log (#5) by placing notches on bottom of log onto locating blocks on log #7 and log #5. See Figure 6.23.
- Place center log (#9) onto front bottom left log (#5) by placing notch on bottom of log #9 onto locating block on log #5. The flat triangle-shaped end of log #9 should be towards front with pointed end of log resting on bottom rear log (#1). See Figure 6.23.

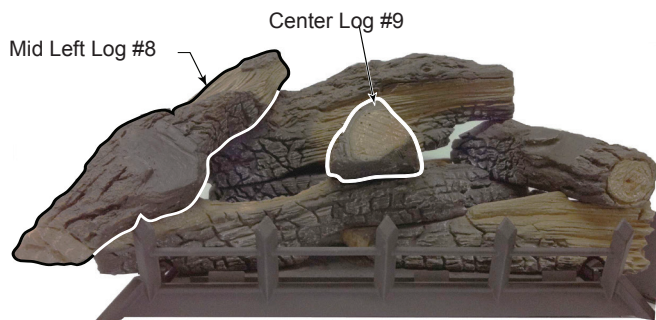

Figure 6.23 - Log #8 & #9 Placement

- Place top front right log (#10) onto mid right log (#6) by placing notch on bottom of log onto locating block on log #6. Rest bottom end of log onto grate bar. See Figure 6.24.
- Place top front left log (#11) onto mid left log (#8) by placing notch on bottom of log onto locating block on log #8. Rest bottom end of log onto grate bar. See Figure 6.24.

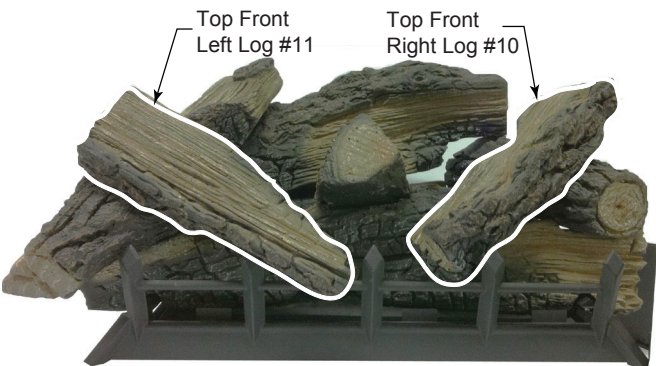

Figure 6.24 - Log #10 & #11 Placement

- Place log #12 onto mid left log (#8) and mid rear log (#7) by placing notch on bottom of log onto locating block on log #8. Rest right end of log onto top of log #7. See Figure 6.25.

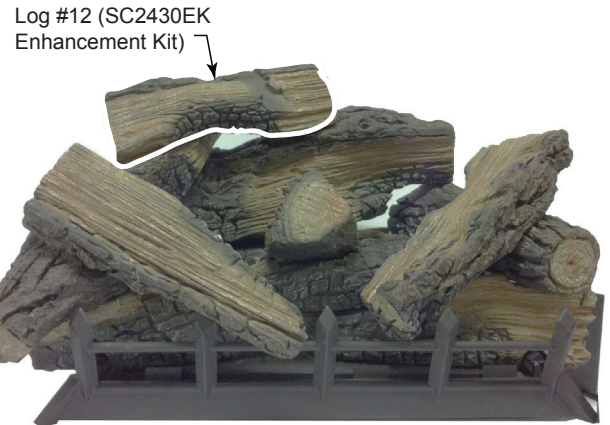

Figure 6.25 - Log #12 Placement

- Place log #13 onto log #12 and top front right log (#10) by placing notch on bottom of log onto locating block on log #12. Rest bottom of log onto log #10 and center log (#9). See Figure 6.26.

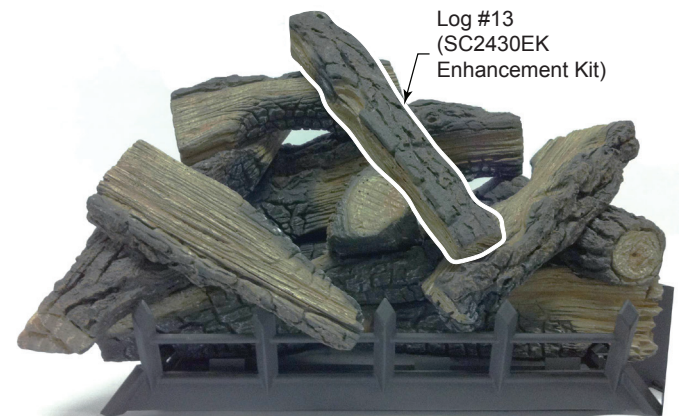

Figure 6.26 - Log #13 Placement

E. BEACHCOMBER LOGS PLACEMENT

1. Place the rear log (#1) on the rear pins located on the log support bar. See Figure 6.27.

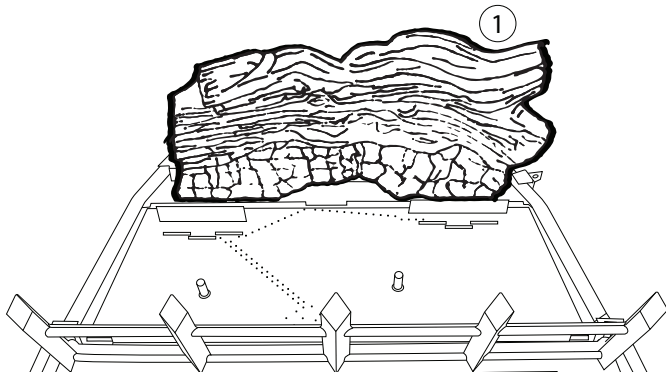

Figure 6.27 - Log #1 Placement

2. Place the front left log (#2) on the pin located on the right side of the burner. See Figure 6.28.

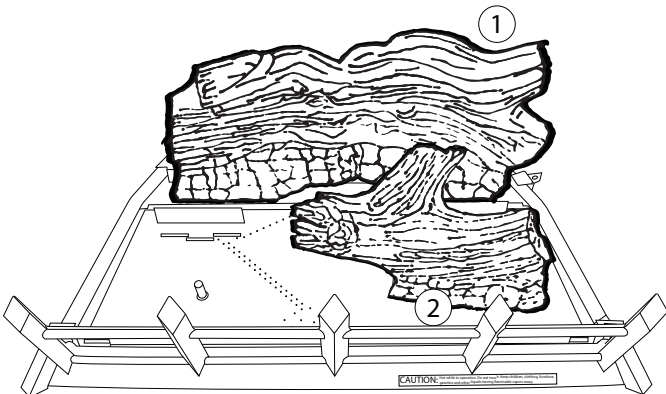

Figure 6.28 - Log #2 Placement

3. Place the front center log (#3) on the pin located on the left side of the burner. See Figure 6.29.

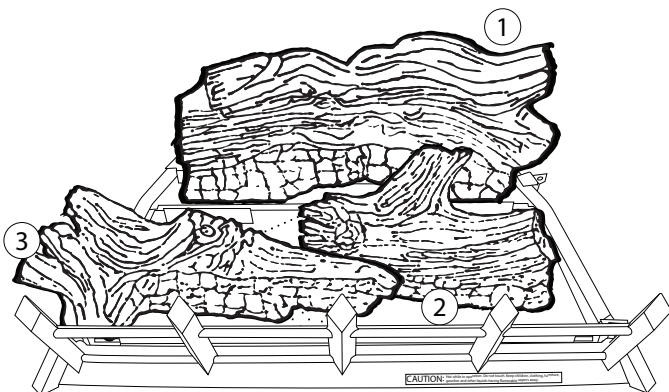

Figure 6.29 - Log #3 Placement

4. Place the right log (#4) on the bar located on the right side of the burner. See Figure 6.30.

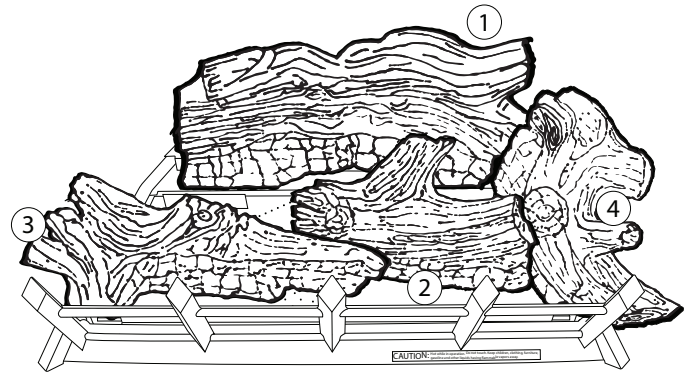

Figure 6.30 - Log #4 Placement

5. Place the top left log (#5) on the left side of the burner allowing the log to rest on top of the front left log (#2). See Figure 6.31.

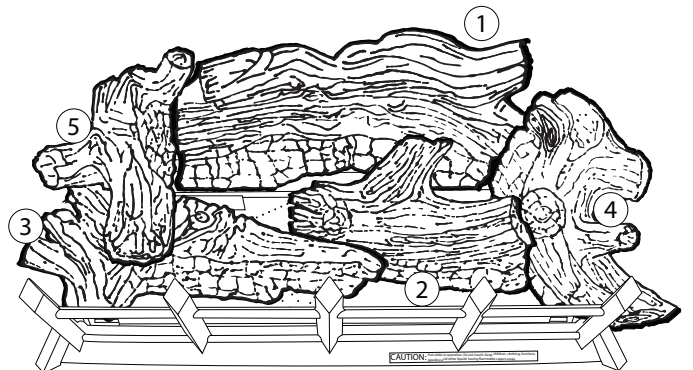

Figure 6.31 - Log #5 Placement

6. Place the top center log (#6) to the right of the pilot orifice allowing the log to rest on top of the front right log (#3) and the front left log (#2). See Figure 6.32.

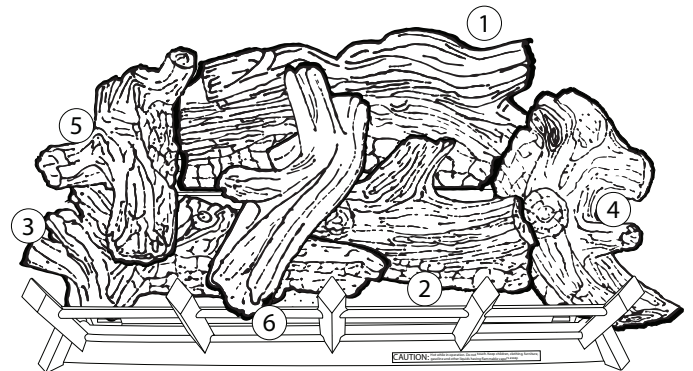

Figure 6.32 - Log #6 Placement

PLACE THE DECORATIVE ROCK

Optional volcanic rock may be placed around the unit on the floor of the firebox. Be sure to avoid any areas on the burner itself.

CAUTION

DO NOT sprinkle volcanic rock on the logs, around the pilot, or on or near burners. This may cause sooting. Place volcanic rock only on the floor of the fireplace.

During initial operation of the new heater, new burning logs and/or rock wool will give off a paper burning smell and orange flames will be present. Simply open the windows for a few hours to vent the odor.

F. Flame Appearance

Flames from the pilot and burner should be visually checked as soon as the heater is installed. In addition, periodically check the flames visually during operation.

Check the Pilot Flame (refer to lighting instructions)

The pilot flame must always be present when the heater is in operation. It should just touch the top of the thermocouple tip for natural. Refer to Figure 6.33 for correct pilot flame.

If the pilot flame does not touch the thermocouple, then the main burner cannot function reliably. Figure 6.34 for incorrect shape of pilot flame.

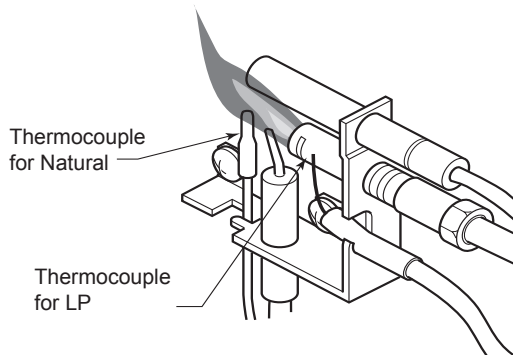

Figure 6.33 - Correct Appearance of Pilot Flame

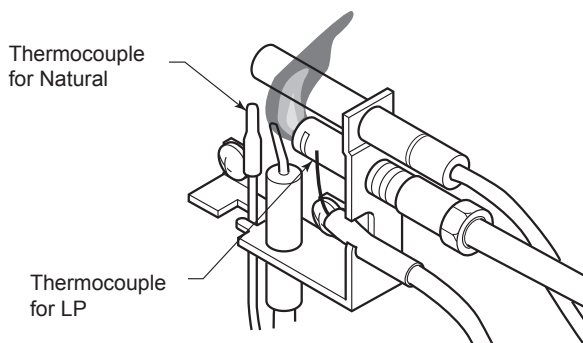

Figure 6.34 - Incorrect Appearance of Pilot Flame

In normal operation at full rate after 15 minutes, the following flame appearances should be observed:

Burner will have a random pattern of yellow flames as shown in Figure 6.35. There should be glowing embers on the front burner. **NOTE: The front flames and embers will be an opaque orange color during the burn off time.**

CAUTION: After a 15 minute pre-heat period, observe all yellow flames to ensure there is no impingement with any log. If any yellow flame is contacting any log, turn off log set and allow to cool. Remove all logs and carefully re-install following log placement instructions precisely. Relight burner and check again for impingement of any flame on log. If flame impingement cannot be eliminated, contact your installer or dealer for assistance. Flame impingement on logs may create soot and possible property damage.

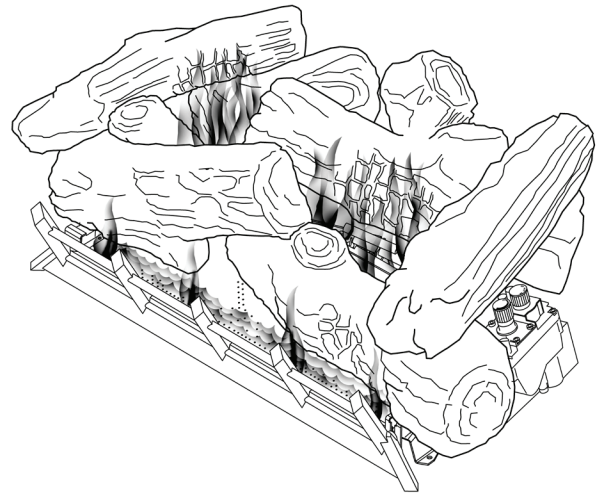

Figure 6.35 - Correct Appearance of Rear Flames

G. Operating Instructions

Avoid any drafts that alter burner flame patterns. Do not allow fans to blow directly into the fireplace. Do not place a blower inside the burn area of the firebox. Ceiling fans may create drafts that alter flame patterns. Sooting and improper burning will result.

During manufacturing, fabricating and shipping, various components of this appliance are treated with certain oils, films or bonding agents. These chemicals are not harmful, but may produce annoying smoke and smells as they are burned off during the initial operation of the appliance, possibly causing headaches or eye or lung irritation. *This is a normal and temporary occurrence.*

The initial break-in operation should last four hours with the burner at the highest setting. Provide maximum ventilation by opening windows or doors to allow odors to dissipate. Any odors remaining after this initial break-in will be slight and will disappear with continued use.

This appliance must not be used with glass doors in the closed position. This can lead to pilot outages and severe sooting outside the fireplace.

Owner's Manual Care and Operation

INSTALLER: Leave this manual with party responsible for use and operation.

OWNER: Retain this manual for future reference.

Contact your dealer with questions regarding installation, operation or service.

NOTICE: DO NOT discard this manual!

**Natural
Blaze Series**



Models:

NB18NV/PV

NB24NV/PV

NB18NIF/PIF

NB24NIF/PIF

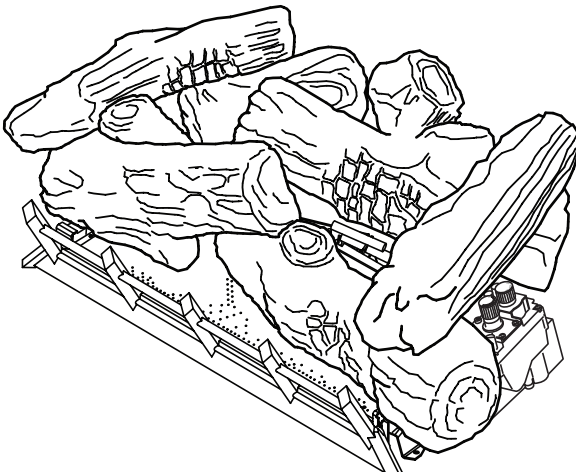

⚠ WARNING:
FIRE OR EXPLOSION HAZARD
Failure to follow safety warnings exactly could result in serious injury, death, or property damage.

- **DO NOT** store or use gasoline or other flammable vapors and liquids in the vicinity of this or any other appliance.
- **What to do if you smell gas**
 - **DO NOT** try to light any appliance.
 - **DO NOT** touch any electrical switch. **DO NOT** use any phone in your building.
 - Leave the building immediately.
 - Immediately call your gas supplier from a neighbor's phone. Follow the gas supplier's instructions.
 - If you cannot reach your gas supplier, call the fire department.
- Installation and service must be performed by a qualified installer, service agency, or the gas supplier.

In the Commonwealth of Massachusetts installation must be performed by a licensed plumber or gas fitter. See appliance installation manual for additional Commonwealth of Massachusetts requirements.

- **DO NOT** install this unit in a bedroom or bathroom.

Read this manual before operating this appliance.
 Please retain this Owner's Manual for future reference.
 Read the Installation Manual before making any installation or finishing changes.

A. Congratulations

Congratulations and thank you for selecting a Monessen vent free gas log set, an elegant and clean alternative to wood burning fireplaces. The gas log set you have selected is designed to provide the utmost in safety, efficiency, and style.

As the owner of a new vent free log set, you'll want to read and carefully follow all of the instructions contained in this owner's manual. Pay special attention to all cautions and warnings.

This owner's manual should be retained for future reference. We suggest that you keep it with your other important documents and product manuals.

The information contained in this owner's manual, unless noted otherwise, applies to all models and gas control systems noted on the cover page.

Your new Monessen gas log set will give you years of durable use and trouble-free enjoyment. Welcome to the Monessen family. We are glad you joined us!

Local Dealer Information

Dealer: Fill in your name, address, phone and email information here and appliance information below.

Dealer Name: _____
 Address: _____

 Phone: _____
 Email: _____

Appliance Information:

Brand: _____ Model Name: _____
 Serial Number: _____ Date Installed: _____

Listing Label Information/Location

The model information regarding your specific gas log set can be found on the rating plate usually located in the control area of the gas log set.

Hearth & Home Technologies
 7571 - 215th Street West
 Lakeville, MN 55044

BAR CODE

MODEL: NB24NIF

BAR CODE

SERIAL:
 ITEM NO: NB24NIF
 GAS: NATURAL



Input Rating: Max. 37000 BTU/Hr.
 Min. 27000 BTU/Hr.

Manifold Pressure: 3.5" W.C.
 For Purpose of Input Adjustment:
 Min. Supply Pressure: 4.5" W.C.
 Max. Supply Pressure: 10.5" W.C.
 Control Type: 35
 Burner Orifice Size: Front 1.8mm, Back 2.5mm
 This unit complies with:
 ANSI Z21.11.2-2016 unvented
 ANSI Z21.60-2012/CSA-2.26-2012

UNVENTED GAS ROOM HEATER
 NOT FOR USE WITH SOLID FUEL

Mantel clearances from top of unit opening:
 At 28" from opening, a mantel of 10" or less is allowed.

This appliance equipped only for altitudes
 0-4500 feet (0-1370m).
 This appliance must be installed in accordance
 with local codes, if any; if none, follow the National
 Fuel Gas Code, ANSI Z223.1, or
 Canadian Installation Codes, CAN/CSA-B149.

4619-990

Type of Gas →

Model Number →

Serial Number →

B. Limited Lifetime Warranty

Hearth & Home Technologies LIMITED LIFETIME WARRANTY

Hearth & Home Technologies, on behalf of its hearth brands (“HHT”), extends the following warranty for HHT gas, wood, pellet and electric hearth appliances that are purchased from an HHT authorized dealer.

WARRANTY COVERAGE:

HHT warrants to the original owner of the HHT appliance at the site of installation, and to any transferee taking ownership of the appliance at the site of installation within two years following the date of original purchase, that the HHT appliance will be free from defects in materials and workmanship at the time of manufacture. After installation, if covered components manufactured by HHT are found to be defective in materials or workmanship during the applicable warranty period, HHT will, at its option, repair or replace the covered components. HHT, at its own discretion, may fully discharge all of its obligations under such warranties by replacing the product itself or refunding the verified purchase price of the product itself. The maximum amount recoverable under this warranty is limited to the purchase price of the product. This warranty is subject to conditions, exclusions and limitations as described below.

WARRANTY PERIOD:

Warranty coverage for consumers begins at the date of installation. In the case of new home construction, warranty coverage begins on the date of first occupancy of the dwelling or six months after the sale of the product by an independent, authorized HHT dealer/distributor, whichever occurs earlier. However, the warranty shall commence no later than 24 months following the date of product shipment from HHT, regardless of the installation or occupancy date. The warranty period for parts and labor for covered components is produced in the following table.

The term “Limited Lifetime” in the table below is defined as: 20 years from the beginning date of warranty coverage for gas appliances, and 10 years from the beginning date of warranty coverage for wood and pellet appliances. These time periods reflect the minimum expected useful lives of the designated components under normal operating conditions.

Warranty Period		HHT Manufactured Appliances and Venting					
Parts	Labor	Gas	Pellet	Wood	Electric	Venting	Components Covered
1 Year		X	X	X	X	x	All parts and material except as covered by Conditions, Exclusions, and Limitations listed
2 years			X	X			Igniters, auger motors, electronic components, and glass
		X	X	X			Factory-installed blowers
				X			Molded refractory panels
		X					Ignition Modules
3 years			X				Firepots, burnpots, mechanical feeders/auger assemblies
5 years	1 year	X					Vent Free burners, Vent Free ceramic fiber logs, Aluminized Burners
			X	X			Castings and Baffles
6 years	3 years			X			Catalyst - limitations listed
7 years	3 years		X	X			Manifold tubes, HHT chimney and termination
10 years	1 year	X					Burners, logs and refractory
Limited Lifetime	3 years	X	X	X			Firebox and heat exchanger, Grate and Stainless Steel Burners, FlexBurn® System (engine, inner cover, access cover and fireback)
90 Days		X	X	X	X	X	All replacement parts beyond warranty period

B. Limited Lifetime Warranty (continued)

WARRANTY CONDITIONS:

- This warranty only covers HHT appliances that are purchased through an HHT authorized dealer or distributor. A list of HHT authorized dealers is available on the HHT branded websites.
- This warranty is only valid while the HHT appliance remains at the site of original installation.
- This warranty is only valid in the country in which the HHT authorized dealer or distributor that sold the appliance resides.
- Contact your installing dealer for warranty service. If the installing dealer or distributor is unable to provide necessary parts, contact the nearest HHT authorized dealer or supplier. Additional service fees may apply if you are seeking warranty service from a dealer other than the dealer from whom you originally purchased the product.
- Check with your dealer in advance for any costs to you when arranging a warranty call. Travel and shipping charges for parts are not covered by this warranty.
- Limited Catalyst Warranty
 - For wood burning products containing a catalyst, the catalyst will be warranted for a six-year period as follows: if the original catalyst or a replacement catalyst proves defective or ceases to maintain 70% of its particulate emission reduction activity (as measured by an approved testing procedure) within 36 months from the purchase date, the catalyst will be replaced for free.
 - From 37 to 72 months a pro-rated credit will be allowed against a replacement catalyst and labor credit necessary to install the replacement catalyst. The proration rate is as follows:

Amount of Time Since Purchase	Credit Towards Replacement Cost
0 - 36 Months	100%
37 - 48 Months	30%
49 - 60 Months	20%
61 - 72 Months	10%

- Any replacement catalyst will be warranted under the terms of the catalyst warranty for the remaining term of the original warranty. The purchaser must provide the name, address, and telephone number of the location where the product is installed, proof of original purchase date, date of failure, and any relevant information regarding the failure of the catalyst.

WARRANTY EXCLUSIONS:

This warranty does not cover the following:

- Changes in surface finishes as a result of normal use. As a heating appliance, some changes in color of interior and exterior surface finishes may occur. This is not a flaw and is not covered under warranty.
- Damage to printed, plated, or enameled surfaces caused by fingerprints, accidents, misuse, scratches, melted items, or other external sources and residues left on the plated surfaces from the use of abrasive cleaners or polishes.
- Repair or replacement of parts that are subject to normal wear and tear during the warranty period are not covered. These parts include: paint, wood and pellet gaskets, firebricks, grates, flame guides, batteries and the discoloration of glass.
- Minor expansion, contraction, or movement of certain parts causing noise. These conditions are normal and complaints related to this noise are not covered by this warranty.
- Damages resulting from: (1) failure to install, operate, or maintain the appliance in accordance with the installation instructions, operating instructions, and listing agent identification label furnished with the appliance; (2) failure to install the appliance in accordance with local building codes; (3) shipping or improper handling; (4) improper operation, abuse, misuse, continued operation with damaged, corroded or failed components, accident, or improperly/incorrectly performed repairs (5) environmental conditions, inadequate ventilation, negative pressure, or drafting caused by tightly sealed constructions, insufficient make-up air supply, or handling devices such as exhaust fans or forced air furnaces or other such causes; (6) use of fuels other than those specified in the operation instructions; (7) installation or use of components not supplied with the appliance or any other components not expressly authorized and approved by HHT; (8) modification of the appliance not expressly authorized and approved by HHT in writing; and/or (9) interruptions or fluctuations of electrical power supply to the appliance.
- Non-HHT venting components, hearth connections or other accessories used in conjunction with the appliance.
- Any part of a pre-existing fireplace system in which an insert or a decorative gas appliance is installed.
- HHT's obligation under this warranty does not extend to the appliance's capability to heat the desired space. Information is provided to assist the consumer and the dealer in selecting the proper appliance for the application. Consideration must be given to the appliance location and configuration, environmental conditions, insulation and air tightness of the structure.

B. Limited Lifetime Warranty (*continued*)

This warranty is void if:

- The appliance has been over-fired, operated in atmospheres contaminated by chlorine, fluorine, or other damaging chemicals. Over-firing can be identified by, but not limited to, warped plates or tubes, deformation/warping of interior cast iron structure or components, rust colored cast iron, bubbling, cracking and discoloration of steel or enamel finishes.
- The appliance is subjected to prolonged periods of dampness or condensation.
- There is any damage to the appliance or other components due to water or weather damage which is the result of, but not limited to, improper chimney or venting installation.

LIMITATIONS OF LIABILITY

- The owner's exclusive remedy and HHT's sole obligation under this warranty, under any other warranty, express or implied, or in contract, tort or otherwise, shall be limited to replacement, repair, or refund, as specified above. In no event will HHT be liable for any incidental or consequential damages caused by defects in the appliance. Some states do not allow exclusions or limitation of incidental or consequential damages, so these limitations may not apply to you. This warranty gives you specific rights; you may also have other rights, which vary from state to state. EXCEPT TO THE EXTENT PROVIDED BY LAW, HHT MAKES NO EXPRESS WARRANTIES OTHER THAN THE WARRANTY SPECIFIED HEREIN. THE DURATION OF ANY IMPLIED WARRANTY IS LIMITED TO DURATION OF THE EXPRESSED WARRANTY SPECIFIED ABOVE.

8 Product Specific Information

A. Appliance Certification



MODEL: NB18NV/PV, NB24NV/PV, NB18NIF/PIF
NB24NIF/PIF
LABORATORY: CSA
TYPE: Unvented Room Heater
STANDARD: ANSI Z21.11.2-2016 (Unvented Heaters)
 ANSI Z21.60-2017-CSA 2.26-2017 (Decorative Gas Appliances for Installation in Solid-Fuel Burning Fireplaces)

This product is listed to ANSI standards for “Unvented Room Heaters” and applicable sections of “Gas Burning Heating Appliances for Manufactured Homes and Recreational Vehicles”, and “Gas Fired Appliances for Use at High Altitudes”.

NOTICE: *This installation must conform with local codes. In the absence of local codes you must comply with the National Fuel Gas Code, ANSI Z223.1—latest edition in the U.S.A.*

NOT INTENDED FOR USE AS A PRIMARY HEAT SOURCE.
 This appliance is tested and approved as either supplemental room heat or as a decorative appliance. It should not be factored as primary heat in residential heating calculations.

Installation and service of this appliance should be performed by qualified personnel. Hearth & Home Technologies recommends HHT Factory Trained or NFI certified professionals.

B. BTU Specifications

Models		Maximum Input BTU/h	Minimum Input BTU/h	Orifice
NB18NV	(0-2000 FT)	28,000	19,000	#38
NB18PV	(0-2000 FT)	27,000	22,000	#52
NB24NV	(0-2000 FT)	37,000	25,000	3.00 mm
NB24PV	(0-2000 FT)	36,000	28,000	#49
NB18NIF	(0-2000 FT)	28,000	19,000	#38
NB18PIF	(0-2000 FT)	27,000	22,000	#52
NB24NIF	(0-2000 FT)	37,000	25,000	3.00 mm
NB24PIF	(0-2000 FT)	36,000	28,000	#49

9 Important Safety and Operating Information

A. Appliance Safety

WARNING! DO NOT operate gas log set before reading and understanding operating instructions. Failure to operate gas log set according to operating instructions could cause fire or injury.

WARNING! Choking Hazard! Keep media out of reach of children.

- Alert children and adults to hazards of high temperatures.

High temperatures may ignite clothing or other flammable materials.

- Clothing, furniture, draperies, and other flammable materials must not be placed on or near the appliance.

Young children should be carefully supervised when they are in the same room as the appliance. Toddlers, young children and others may be susceptible to accidental contact burns.

- A physical barrier is recommended if there are at risk individuals in the house.
- To restrict access to a fireplace, install an adjustable safety gate to keep toddlers, young children, pets and other at risk individuals out of the room and away from hot surfaces.
- Install a switch lock or a wall/remote control with child protection lockout feature.
- Keep remote controls out of reach of children.
- Never leave children alone near a hot fireplace, whether operating or cooling down.
- Teach children to NEVER touch the fireplace.
- Consider not using the fireplace when children will be present.

Contact your dealer for more information, or visit: www.hpba.org/safety-information.

To prevent unintended operation when not using your fireplace for an extended period of time (summer months, vacations, trips, etc):

- Remove batteries from remote controls.
- Turn off wall controls.
- Turn off pilot or gas valve.

Clear Space

WARNING! DO NOT place combustible objects in front of the fireplace. High temperatures may start a fire. See Figure 9.1.

Avoid placing candles, electronics and other heat-sensitive objects on mantel or hearth. Heat may damage these objects.

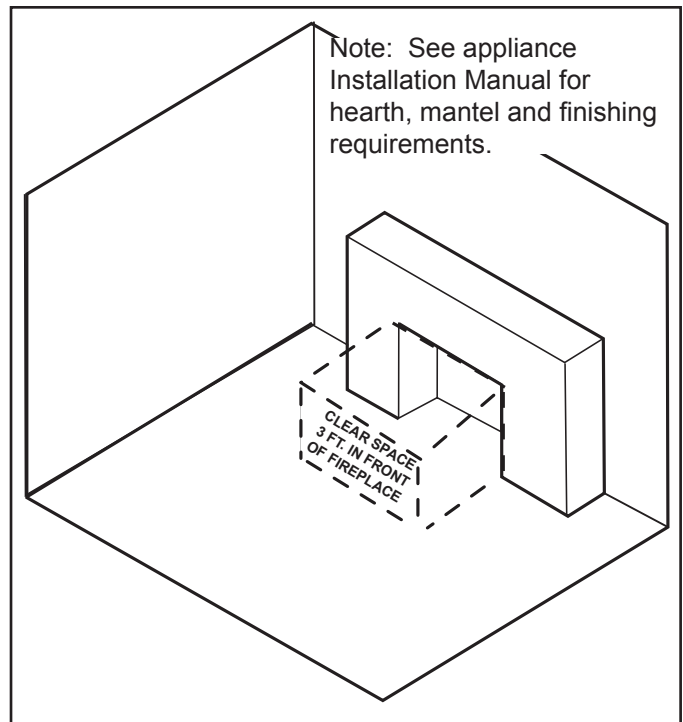

Figure 9.1 Clear Space

Over Firing

The appliance is considered to be over firing if the flames are contacting the top of the firebox. Call a qualified service technician to service the appliance.

Important Safety and Operating Information (continued)

OWNER

Please retain these instructions for future reference.

WARNING

- **Any change to this heater or its controls can be dangerous.**
- **Improper installation or use of the heater can cause serious injury or death from fire, burns, explosion or carbon monoxide poisoning.**
- **Do not allow fans to blow directly into the fireplace. Avoid any drafts that alter burner flame patterns.**
- **Do not use a blower insert, heat exchanger insert or other accessory, not approved for use with this heater where applicable.**

1. Due to high temperatures, the appliance should be located out of traffic and away from furniture and draperies.
2. Children and adults should be alerted to the hazard of high surface temperature and should stay away to avoid burns or clothing ignition.
3. Young children should be carefully supervised when they are in the same room with the appliance.
4. Do not place clothing or other flammable material on or near the appliance.
5. Any safety screen removed for servicing an appliance, must be replaced prior to operating the heater.
6. Installation and repair should be done by a qualified service person. To prevent malfunction and/or sooting, an unvented gas heater should be cleaned before use and at least annually by a professional service person. More frequent cleaning may be required due to excessive lint from carpeting, bedding materials, etc. It is imperative that control compartments, burners and circulating air passageways be kept clean.
7. **WARNING:** Any change to this heater or its controls can be dangerous.
8. Unvented gas room heaters are a supplemental zone heater. They are not intended to be the primary heating appliance.
9. **CARBON MONOXIDE POISONING:** Early signs of carbon monoxide poisoning are similar to the flu with headaches, dizziness and/or nausea. If you have these signs, obtain fresh air immediately. Have the heater serviced as it may not be operating properly.
10. The installation must conform with local codes or, in the absence of local codes, with the **National Fuel Gas Code, ANSI Z223.1/NFPA54.**
11. This unit complies with ANSI Z21.11.2 *Unvented Heaters*, latest edition and **ANSI Z21.60-2012.**
12. Do not install the heaters in a bathroom or bedroom.
13. Correct installation of the logs, proper location of the heater, and annual cleaning are necessary to avoid potential problems with sooting. Sooting, resulting from improper installation or operation, can settle on surfaces outside the fireplace. Refer to log placement instructions for proper installation.
14. Avoid any drafts that alter burner flame patterns. Do not allow fans to blow directly into fireplace. Do not place a blower inside burn area of firebox. Ceiling fans may create drafts that alter burner flame patterns. Sooting and improper burning will occur.
15. **Caution:** Candles, incense, oil lamps, etc. produce combustion by-products including soot. Vent-free room heater will not filter or clean soot produced by these types of products. In addition, the smoke and/or aromatics (scents) may be reburned in the vent-free appliance which can produce odors. It is recommended to minimize the use of candles, incense, etc. while the vent-free appliance is in operation.
16. This heater shall not be installed in a room or space unless the required volume of indoor combustion air is provided by the method described in the *National Fuel Gas Code, ANSI Z223.1/NFPA 54*, the *International Fuel Gas Code* or applicable local codes.
17. Keep room area clear and free from combustible materials, gasoline and other flammable vapors and liquids.
18. Unvented gas room heaters emit moisture into the living area. In most homes of average construction, this does not pose a problem. In houses of extremely tight construction, additional mechanical ventilation is recommended.
19. During manufacturing, fabricating and shipping, various components of this appliance are treated with certain oils, films or bonding agents. These chemicals are not harmful but may produce annoying smoke and smells as they are burned off during the initial operation of the appliance; possibly causing headaches or eye or lung irritation. This is a normal and temporary occurrence.

20. Input ratings are shown in BTU per hour and are for elevations up to 4,500 feet. For elevations above 4,500 each 1,000 feet above sea level. Refer to the National Fuel Gas Code.
21. The appliance and its appliance main gas valve must be disconnected from the gas supply piping system during any pressure testing of that system at test pressures in excess of ½ psig (3.5 kPa).
22. The appliance must be isolated from gas supply piping system by closing its equipment shutoff valve during any pressure testing of the gas supply piping system at test pressures equal to or less than ½ psig (3.5 kPa).
23. Do not use this room heater if any part has been under water. Immediately call a qualified service technician to inspect the room heater and to replace any part of the control system and any gas control which has been under water.
24. Never burn solid fuels in a fireplace where a unvented room heater is installed.

BUILDING CODE INFORMATION

Adhere to all local codes or, in their absence, the latest edition of THE NATIONAL FUEL GAS CODE ANSI Z223.1 or NFPA54 which can be obtained from:

American National Standards Institute, Inc.

1430 Broadway
New York, NY 10018

or

National Fire Protection Association, Inc.

Batterymarch Park
Quincy, MA 02269

B. General Operating Parts

Figure 9.2 references the general operating parts of the appliance.

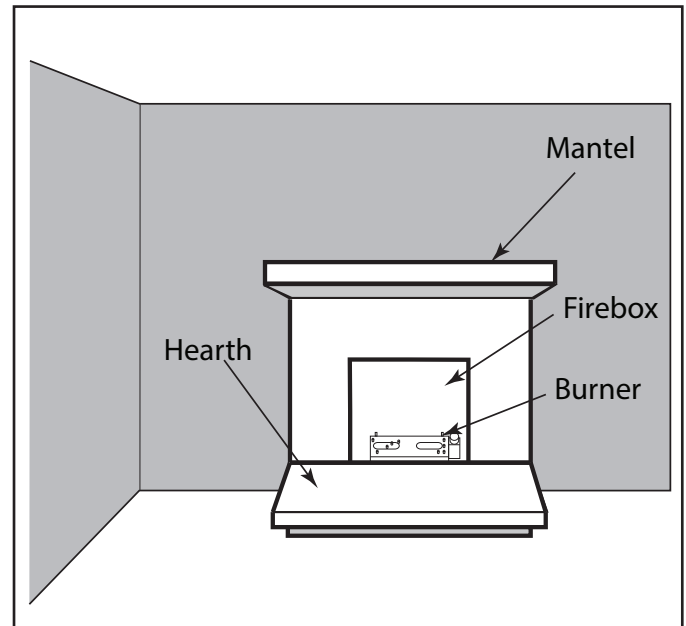

Figure 9.2 General Operating Parts

C. Fuel Specifications

WARNING! Risk of Fire or Explosion! Appliance must be set up for compatible gas type!

- This appliance is designed to operate on either natural gas or propane. Make sure the appliance is compatible with gas type selected for installation site.

WARNING! Risk of Fire! Comply with all minimum clearances to combustibles as specified in the installation instructions.

D. Before Lighting Appliance

Before operating this heater for the first time, **have a qualified service technician:**

- Verify all shipping materials have been removed from inside and/or underneath the gas log set
- Review proper placement of logs
- Ensure that there are no gas leaks

10 Lighting Instructions

A. Millivolt

FOR YOUR SAFETY READ BEFORE LIGHTING

⚠ WARNING

If you do not follow these instruction exactly, a fire or explosion may result causing property damage, personal injury or loss of life.

- A. This appliance is equipped with a piezo ignition device which lights the pilot. If piezo is not working properly see *Match Lighting Instructions*.
- B. BEFORE OPERATING smell all around the appliance area for gas. Be sure to smell next to the floor because some gas is heavier than air and will settle on the floor.

WHAT TO DO IF YOU SMELL GAS:

- Do not attempt to light any appliance.
 - Do not touch any electric switch; do not use any phone in your building.
 - Immediately call your gas supplier from a neighbor's phone. Follow the gas supplier's instructions.
 - If you cannot reach your gas supplier, call the fire department.
- C. Use only your hand to push in, or turn the gas control knob. Never use tools. If the knob will not push in or turn by hand, don't try to repair it. Call a qualified service technician. Force or attempted repair may result in a fire or explosion.
 - D. Do not use this appliance if any part of it has been under water. Immediately call a qualified service technician to inspect the appliance and to replace any part of the control system and any gas control that has been under water.

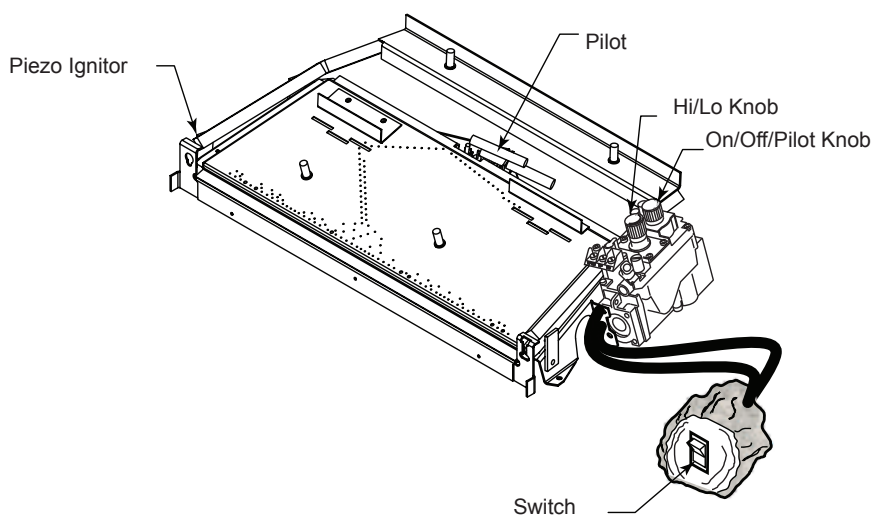

Figure 10.1 - Location of Piezo Ignitor, Control Knobs and Switch

Lighting Instructions (continued)

MILLIVOLT CONTROL LIGHTING INSTRUCTIONS

1. STOP! Read the safety information label.
2. Make sure the manual shutoff valve is fully open.
3. This gas log set is equipped with an ignition device (piezo) which automatically lights the pilot. If piezo ignitor does not light the pilot, refer to instructions for *Match Lighting Instructions*.
4. Turn gas control knob clockwise ↻ to the OFF position and turn ON/OFF switch to OFF position.
5. Wait (5) minutes to clear out any gas. Then smell for gas, including near the floor. If you smell gas, STOP! Follow the instructions under *What To Do If You Smell Gas*.
6. From OFF position, turn the gas control knob counterclockwise ↻ to IGN position. Push in control knob for 5 seconds. **NOTE: If you are running the heater for the first time, it may be necessary to press in the control knob for 30 seconds or longer to allow air to bleed out of the gas piping.**
7. With the control knob pushed in, push in and release the piezo ignitor button to light the pilot.
8. Continue pushing the control knob in for a further 60 seconds to prevent the flame detector from shutting off the gas while the probe is warming up. Release the control knob.
9. Turn gas control knob counterclockwise ↻ to the ON position.
10. After the pilot has been lit for one minute, the burners can be turned on. Turn the ON/OFF switch to ON position.
11. If the gas logs will not operate, follow the instructions To Turn Off Gas To Heater below and call your service technician or gas supplier.

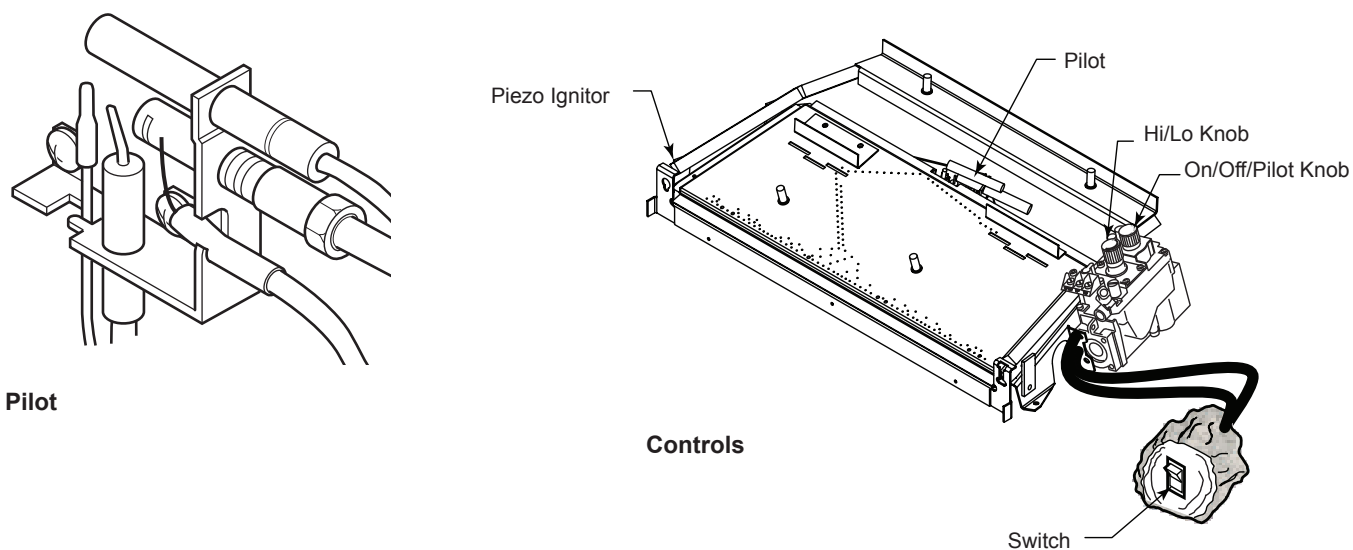

Figure 10.2 - Piezo Ignitor

TO TURN OFF GAS TO HEATER

1. Turn control knob clockwise ↻ to OFF position to completely shut off the heater.
2. If applicable: Turn ON/OFF switch to OFF position and/or set thermostat (if present) to lowest setting.
3. If applicable: Turn off all electric power to the heater.

Lighting Instructions (continued)

MATCH LIGHTING INSTRUCTIONS

1. Remove any items necessary for easy access to the pilot (for example: logs, screens, etc.).
2. Follow appropriate lighting instructions found previously. Instead of pushing and releasing the piezo button, light a match and hold the flame to the end of the pilot and ignite the pilot.
3. After control knob has been released and pilot stays lit, reinstall any items that were removed for pilot access.
4. Call a qualified service technician for repair or replacement of the piezo ignitor.

FOR YOUR SAFETY READ BEFORE LIGHTING

⚠ WARNING

If you do not follow these instruction exactly, a fire or explosion may result causing property damage, personal injury or loss of life.

- A.** This appliance is equipped with an ignition device which automatically lights the pilot. Refer to the instructions.
- B.** BEFORE OPERATING smell all around the appliance area for gas. Be sure to smell next to the floor because some gas is heavier than air and will settle on the floor.

WHAT TO DO IF YOU SMELL GAS:

- Do not attempt to light any appliance.
 - Do not touch any electric switch; do not use any phone in your building.
 - Immediately call your gas supplier from a neighbor's phone. Follow the gas supplier's instructions.
 - If you cannot reach your gas supplier, call the fire department.
- C.** Use only your finger to push in the master switch. Never use tools. If the switch will not function by hand, do not try to repair it. Call a qualified service technician. Force or attempted repair may result in a fire or explosion.
 - D.** Do not use this appliance if any part of it has been under water. Immediately call a qualified service technician to inspect the appliance and to replace any part of the control system and any gas control that has been under water.

FOR YOUR SAFETY READ BEFORE LIGHTING

WARNING: If you do not follow these instructions exactly, a fire or explosion may result causing property damage, personal injury or loss of life.

- A. This appliance is equipped with an intermittent pilot ignition (IPI) device which automatically lights the burner. **DO NOT** try to light the burner by hand.
- B. **BEFORE LIGHTING**, smell all around the appliance area for gas. Be sure to smell next to the floor because some gas is heavier than air and will settle on the floor.
- WHAT TO DO IF YOU SMELL GAS**
- **DO NOT** try to light any appliance.
 - **DO NOT** touch any electric switch; do not use any phone in your building.
 - Immediately call your gas supplier from a neighbor's phone. Follow the gas supplier's instructions.
 - If you cannot reach your gas supplier, call the fire department.
- C. **DO NOT** use this appliance if any part has been under water. Immediately call a qualified service technician to inspect the appliance and to replace any part of the control system and any gas control which has been under water.

LIGHTING INSTRUCTIONS (IPI)

1. This appliance is equipped with an ignition device which automatically lights the burner. **DO NOT** try to light the burner by hand.
2. Wait five (5) minutes to clear out any gas. Then smell for gas, including near the floor. If you smell gas, **STOP!** Follow "B" in the Safety Information located on the top of this label. If you do not smell gas, go to next step.
3. To light the burner:
Equipped with wall switch: Turn ON/OFF switch to ON.
Equipped with remote or wall control: Press ON or FLAME button.
Equipped with thermostat: Set temperature to desired setting.
4. If the appliance does not light after three tries, call your service technician or gas supplier.

**GAS
VALVE**

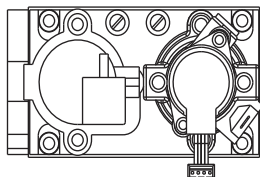

TO TURN OFF GAS TO APPLIANCE

1. Equipped with wall switch: Turn ON/OFF switch to OFF.
Equipped with remote or wall control: Press OFF button.
Equipped with thermostat: Set temperature to lowest setting.
2. Service technician should turn off electric power to the control when performing service.

4604-200

WARNING:

DO NOT CONNECT LINE VOLTAGE (110/120 VAC OR 220/240 VAC) TO THE CONTROL VALVE.

Improper installation, adjustment, alteration, service or maintenance can cause injury or property damage. Refer to the owner's information manual provided with this appliance. For assistance or additional information, consult a qualified installer, service agency or the gas supplier.

This appliance needs fresh air for safe operation and must be installed so there are provisions for adequate combustion and ventilation air.

CAUTION:

Keep burner and control compartment clean. See installation and operating instructions accompanying appliance.

Hot while in operation. **DO NOT** touch. Keep children, clothing, furniture, gasoline and other liquids having flammable vapors away.

NOT FOR USE WITH SOLID FUEL

This appliance must be installed in accordance with local codes, if any; if none, follow the *National Fuel Gas Code, ANSI Z223.1/ NFPA 54, or the National Gas and Propane Installation code, CSA B149.1.*

For additional information on operating your
Hearth & Home Technologies fireplace, please refer to www.fireplaces.com.

4604-201

C. Initial Use

Initial Break-in Procedure

- The burner should run three to four hours continuously on high.
- Turn the burner off and allow it to completely cool.

This cures the materials used to manufacture the burner.

NOTICE! Open windows for air circulation during heater break-in.

- *Some people may be sensitive to smoke and odors.*
- *Smoke detectors may activate.*

RC300

IntelliFire Plus™ Multifunction Remote Control Installation & Operating Instructions

Hearth & Home Technologies disclaims any responsibility for, and the warranty will be voided by, the following actions:

- Installation and use of any damaged system component.
- Modification of the system component.
- Installation other than as instructed by Hearth & Home Technologies.
- Installation and/or use of any component part not approved by Hearth & Home Technologies.

Any such action may cause a fire hazard.

- Read, understand and follow these instructions for safe installation and operation.

Introduction

The RC300 multifunctional remote control is designed to control light, flame height and interior dome lighting. The RC300 is equipped with thermostat functions which can automatically control the temperature in the room in which it is installed. The control is only for use with the Hearth & Home Technologies IntelliFire Plus™ system (IPI).

Installation Precautions

This remote control is tested and safe when installed in accordance with this installation manual. Do not install any components that may be damaged.

Do not modify, disassemble, or substitute any of the components included with this kit. Installation of this unit must be done by a qualified service technician.

Placement of this remote control may affect performance. An assessment of the space should be done prior to installation for optimum performance.

Determine Location

Determine the location for the remote control. The selected location should be in the same space as the fireplace. Never place this unit in a separate room. The remote control must be placed within 30 feet (9.14 m) of the heater but should not be exposed to extreme heat.

The RC300 is approved for interior installation and should not be used in exterior applications.

- Keep remote control out of reach of children.

FCC Requirements

WARNING! Risk of Fire! Changes or modifications to this unit not expressly approved by the party responsible for compliance could void the user's authority to operate the equipment.

Note: This equipment has been tested and found to comply with the limits for a Class B digital device, pursuant to Part 15 of the FCC Rules. These limits are designed to provide reasonable protection against harmful interference in a residential installation. This equipment generates, uses, and can radiate radio frequency energy and, if not installed and used in accordance with the instructions, may cause harmful interference to radio communications. However, there is no guarantee that interference will not occur in a particular installation. If this equipment does cause harmful interference to radio or television reception, which can be determined by turning the equipment off and on, the user is encouraged to try to correct the interference by one or more of the following measures:

- Reorient or relocate the receiving antenna.
- Increase the separation between the equipment and receiver.
- Connect the equipment into an outlet on a circuit different from that to which the receiver is connected.
- Contact the dealer or an experienced radio TV technician for help.

Changing Temperature Scale

To change the temperature display between Celsius and Fahrenheit, remove the battery cover from the back of the remote control and slide the switch to your desired temperature scale (see Figure 11.1). The screen will automatically change the indicators on the room temperature and set temperature portion.

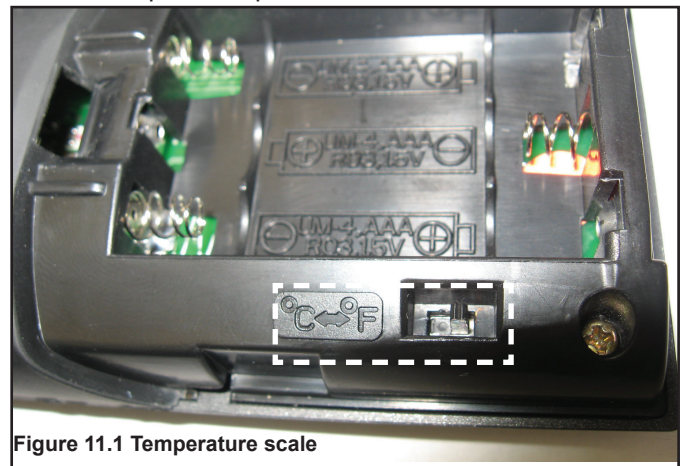

Figure 11.1 Temperature scale

Installation of Remote Control Housing

CAUTION! Risk of Fire! DO NOT install damaged or modified components. Warranty will be voided if damaged or modified components are installed.

Kit components: One remote control, two #6 screws, two wall anchors and 3 AAA batteries. If batteries are properly installed the remote will turn on

1. Remove remote control components from packaging.
2. Remove battery cover from the back of the remote by sliding it down and install 3 AAA batteries.

To prevent unintended operation when not using your heater for an extended period of time (summer months, vacation, trips, etc):

- Remove batteries from remote control.
 - Remove batteries from battery pack.
3. Secure the remote control housing on a flat wall surface using the two screws and wall anchors provided. See Figure 11.2.

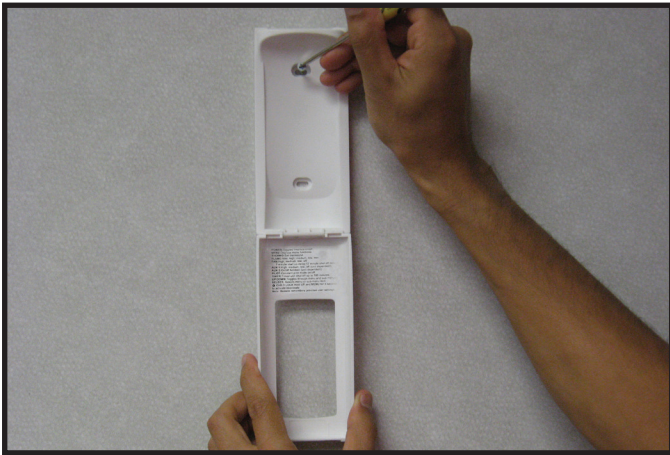

Figure 11.2. Mounting Remote Control Housing

4. Place remote control inside housing. See Figure 11.3.



Figure 11.3. Remote in Housing

5. Close the housing door. See Figure 11.4.



Figure 11.4. Mounting Remote Control Housing

Programming the RC300 to the Control Module

CAUTION! Risk of burns! DO NOT program the remote control to the control module when heater is hot.

- Verify the ON/OFF/REMOTE switch is in the REMOTE position. Green LED light will blink three times and wall switch will beep once 5 seconds later when ready. See Figure 11.5.
- Using a small item (such as a paper clip) press and release the LEARN button located near the ON/OFF/REMOTE switch. See Figure 11.5.
- Control module will beep once and LED will blink green for 10 seconds.
- While the LED is blinking, press the POWER button on the remote control. A double beep will come out of the control module to indicate that it has been programmed successfully.

NOTICE: Up to three remote controls can be programmed into the control module. Simply press a button on the other remote controls during the 10 second programming process to add another remote into the system. It is recommended to program only one RC300 remote control.

To clear memory in the control module, use a small item (such as a paper clip) to press and release the LEARN button. Control module will beep once and LED will blink green for 10 seconds **DO NOT** press any buttons on the remote during the ten seconds that the green LED blinks. The memory will be cleared. Note that the RC300 will not be programmed if it's in STANDBY mode. Press the ON/OFF button twice to switch to IDLE mode.

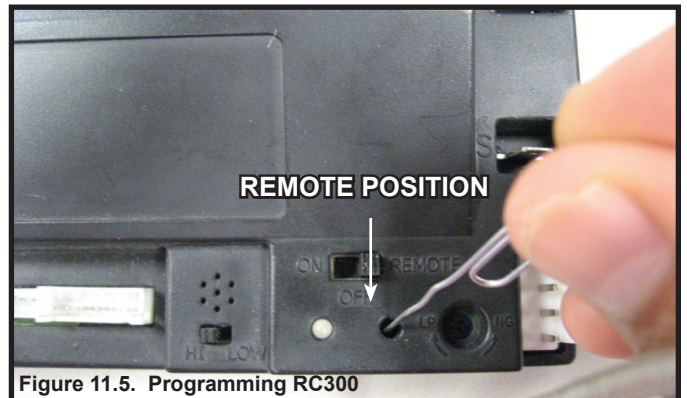

Figure 11.5. Programming RC300

Display Screen

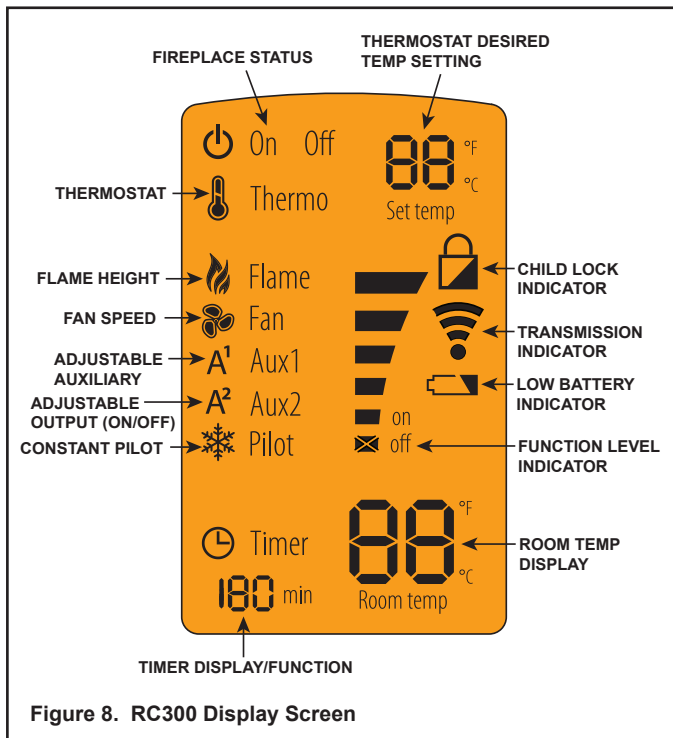

Figure 8. RC300 Display Screen

Idle When Remote is in ON Mode

The remote control will go into an idle mode if no buttons are pressed within 5 seconds. Press any button to resume full functionality. In idle mode, only active functions will show on the screen.

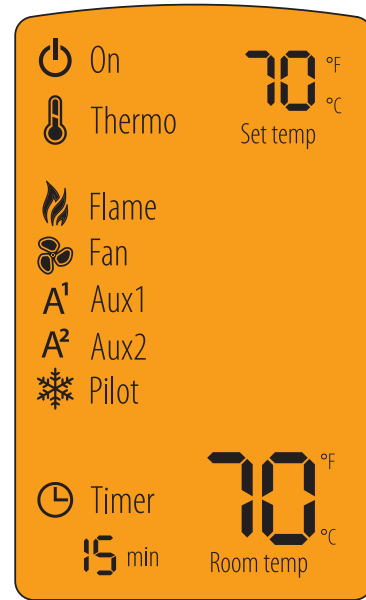







Figure 9. RC300 Idle Mode

Function Buttons

-  Use POWER button to turn the unit on and off.
-  Use MENU button to display the menu functions. Only functions that can be activated will be displayed. *For example: Flame Height will not be displayed when the remote status is OFF.*
-  Use the SELECT button to select the current feature.
-  Use the UP and DOWN arrows to toggle through the menu functions and value selections in the submenus.
- 

Standby mode

The remote control will go into a standby mode if no buttons are pressed within 5 minutes. Press the POWER button to reactivate the remote control to ON mode. Active functions will be displayed

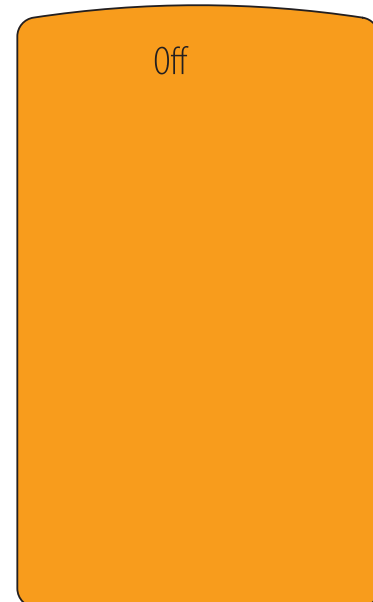

Figure 10. RC300 Standby Mode

About ON Mode

- All functions can be accessed when the remote control is in the ON mode.
- Only active functions will be displayed when the remote control is in the ON mode.

Turning On the Heater

- Press the POWER button to turn the heater ON. The heater will first ignite the pilot. Once the pilot flame is established the main burner will be lit.

NOTICE: Whenever the heater is cycled from OFF to ON, the main burner will light on high for 10 seconds before returning to the previous user setting.

Adjusting Flame Height

- Press the MENU button to activate the menu.
- Using the UP and DOWN arrows highlight the FLAME icon and press SELECT.
- Use the UP and DOWN arrows to adjust the FLAME HEIGHT, then press SELECT. The FLAME HEIGHT can be adjusted to 5 different settings.

NOTICE: FLAME HEIGHT will not be adjustable for first ten seconds when heater is turned on.

NOTICE: The system will remember the previous FLAME HEIGHT setting and will automatically adjust after 10 seconds.

NOTICE: Some models use fixed valves, which cannot be adjusted.

Adjusting Thermostat

- Press the MENU button to activate the menu.
- Using the UP and DOWN arrows highlight the THERMO icon and press SELECT.
- Use the UP and DOWN arrows to turn the THERMO ON or OFF, then press SELECT (the SET TEMP will start blinking). Using the UP and DOWN arrows select the desired temperature and press SELECT.

NOTICE: If the THERMO function is on, the SET TEMP can be adjusted at any time by pressing the UP and DOWN arrows.

NOTICE: As the ROOM TEMP (RT) approaches SET TEMP (ST), the remote system will automatically adjust the flame height. If the RT rises above ST, the heater will shut down the main burner. After this, the heater will turn back on after the RT drops below the ST.

NOTICE: The system requires a two degree Fahrenheit or higher temperature difference between RT and ST for the heater to turn on.

NOTICE: The system will remember the previous TEMPERATURE setting when THERMOSTAT mode is cycled ON or OFF.

NOTICE: If your installation includes an optional wired ON/OFF wall switch, it should be in the OFF position when using the RC300 in thermostat mode.

Adjusting Timer

- Press the MENU button to activate the menu.
- Using the UP and DOWN arrows highlight the TIMER icon and press SELECT.
- Use the UP and DOWN arrows to turn the TIMER ON or OFF, then press SELECT. Using the UP and DOWN arrows select the desired set time and press SELECT. Timer operates in increments of 15, 30, 45, 60, 90, 120 and 180 minutes.

Setting the Child Lock

- Press and hold the MENU and UP arrow buttons simultaneously for 4 seconds to enable or disable the child lock feature.

NOTICE: No functions will be usable until child lock feature is disabled.

Manual Heater Shutoff

In the unlikely event that the remote wall switch malfunctions and will not turn off the heater, call your dealer for service assistance. In the meantime, you may choose one of the following actions to turn off the heater:

CAUTION! Risk of burns! Heater surfaces are hot when operating and during cool down. Use care and wear gloves when opening the front and accessing components inside the heater.

Check remote screen for battery level indicator, replace the batteries if low battery is indicated (See Figure 9).

The heater may be manually shut down by one of the following methods:

Turn off the control module:

- Move switch to OFF (See Figure 7).

Disconnect power to the control module:

- Unplug the control module and/or remove batteries.

Shut off gas to the control:

- Locate the gas shut-off valve to the left of the gas control.
- Rotate the valve 90 degrees to turn off gas supply.
- **To preserve battery life, do not use the HI/LO flame or THERMOSTAT options.**

12 Maintenance and Service

Any safety screen removed for servicing must be replaced prior to operating the unvented room heater.

When properly maintained, your fireplace will give you many years of trouble-free service. **Contact your dealer** to answer questions regarding proper operation, troubleshooting and service for your appliance. Visit www.monessenhearth.com to locate a dealer. We recommend annual service by a qualified service technician.

A. Maintenance: Frequency and Tasks

The matrix below is an overview of maintenance tasks to be performed on the appliance. Section B gives details and instructions needed to assist the appropriate person in performing the tasks.

Task	Frequency	To be completed by
Pilot Inspection & Cleaning	Annually	Qualified Service Technician
Log Inspection	Annually	
Firebox Inspection	Annually	
Burner Ignition & Operation	Annually	

B. Maintenance Tasks: Qualified Service Technician

The following tasks must be performed by a qualified service technician.

Pilot

Frequency: Annually

By: Qualified Service Technician

Tools needed: Small soft brush, pipe cleaner

- Inspect and remove dust, spider webs and lint
- Gently run pipe cleaner through air intake port

Firebox

Frequency: Annually

By: Qualified Service Technician

Tools needed: Protective gloves, sandpaper, steel wool, cloths, mineral spirits, primer and touch-up paint.

- Inspect for paint condition, warped surfaces, corrosion or perforation. Sand and repaint as necessary.
- Replace fireplace if firebox has been perforated.

C. Burner Ignition and Operation

Frequency: Annually

By: Qualified Service Technician

Tools needed: Protective gloves, vacuum cleaner, whisk broom, flashlight, voltmeter, indexed drill bit set, and a manometer.

- Verify burner is properly secured and aligned with pilot or igniter.
- Clean off burner top, inspect for plugged ports, corrosion or deterioration. Replace burner if necessary.
- Inspect for lifting or other flame problems.
- Inspect orifice for soot, dirt and corrosion. Verify orifice size is correct. See Service Parts List for proper orifice sizing.
- Verify manifold and inlet pressures. Adjust regulator as required.
- Inspect pilot flame pattern and strength. See Figure 12.1 and 12.2 for proper pilot flame pattern. Clean or replace orifice spud as necessary.

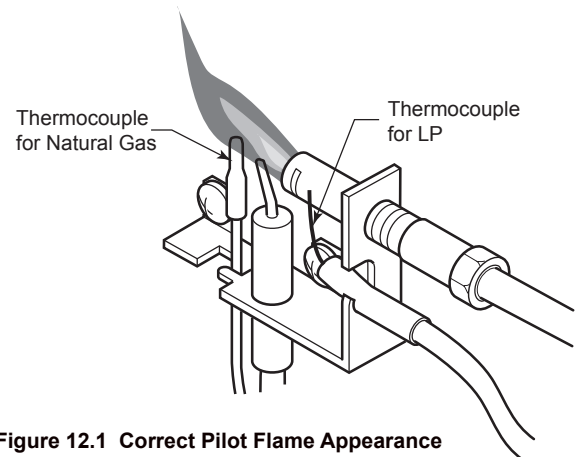

Figure 12.1 Correct Pilot Flame Appearance

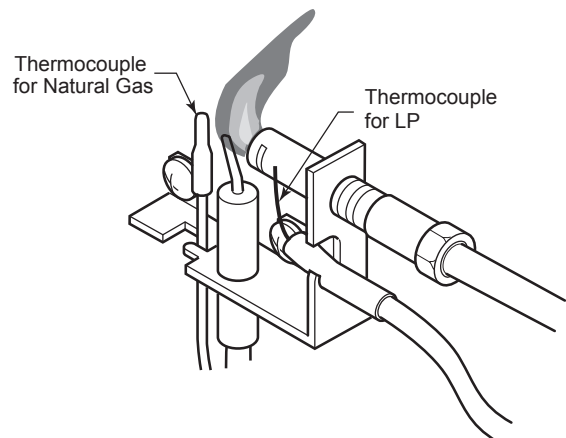

Figure 12.2 Incorrect Pilot Flame Appearance

D. Cleaning and Servicing

Annual inspection and cleaning by your dealer or qualified service technician is recommended to prevent malfunction and/or sooting.

 WARNING
--

Turn off heater and allow to cool before cleaning.

Remove logs, handling carefully by holding gently at each end. Gloves are recommended to prevent skin irritation from logs. If skin becomes irritated, wash gently with soap and water. Refer to manual for correct log placement.

PERIODIC CLEANING - Refer to parts diagram for location of items discussed below.

- Do not use cleaning fluid to clean logs or any part of heater.
- Brush logs with soft bristle brush or vacuum with brush attachment.
- Vacuum loose particles and dust from the front and rear burner, control and piezo covers and grate weldment.
- Inspect and clean burner air intake holes. Remove lint or particles with vacuum, brush, or pipe cleaners. **Failure to keep air intake holes clean will result in sooting and poor combustion.**
- External case should be dusted and wiped with a wet soapy cloth.

ANNUAL CLEANING/INSPECTION - Refer to parts diagram for location of items discussed below.

- Inspect and clean burner air intake holes. Remove lint or particles with vacuum, brush or pipe cleaners. **Failure to keep air intake holes clean will result in sooting and poor combustion.**
- Inspect and clean all burner ports.
- Inspect ODS pilot for operation and accumulation of lint at air intake holes.
- Verify flame pattern and log placement for proper operation.
- Verify smooth and responsive ignition of main burner and rear burner.
- Replace battery in remote control device.

13 Troubleshooting

⚠ WARNING

Turn appliance OFF and allow to cool before servicing. Only a qualified service person should service and repair the heater.

A. Millivolt Control System

NOTE: All troubleshooting items are listed in order of operation.

PROBLEM	POSSIBLE CAUSE	SOLUTION
When ignitor button is pressed, there is no spark at ODS/pilot.	Ignitor electrode positioned wrong.	Replace ignitor.
	Ignitor electrode is broken.	Replace ignitor.
	Ignitor electrode not connected to ignitor cable.	Reconnect ignitor cable.
	Ignitor cable pinched or wet. Keep ignitor cable dry.	Free ignitor cable if pinched by any metal or tubing.
	Broken ignitor cable.	Replace ignitor cable.
	Bad piezo ignitor.	Replace piezo ignitor.
Appliance produces unwanted odors.	Appliance burning vapors from paint, hair spray, glues, etc.	Ventilate room. Stop using odor causing products while heater is running.
	Gas leak.	Locate and correct all leaks.
	Initial burn off.	Ventilate room and turn unit on high until odor is gone. Odor should be gone after six hours of continuous use.
Appliance shuts off during use.	Not enough fresh air is available for ODS/pilot to operate.	Open window and/or door for ventilation.
	Low line pressure.	Contact local gas company.
	ODS/pilot is partially clogged.	Clean ODS/pilot.
	Defective thermopile.	Check wire connections. Check output should be 500 millivolts across TH/TP and TP Terminals with ON/OFF switches off.
	Restrictions in incoming air flow.	Check for bottom riser on glass door, sunken fireplace, excessive lava rock/cinders densely packed against grate.
Gas odor even when control knob is in OFF position.	Gas leak.	Locate and correct all leaks.
	Control valve defective.	Replace control valve.
When ignitor button is pressed, there is spark at ODS pilot, but no ignition.	Gas supply turned off or manual shutoff valve closed.	Turn on gas supply or open manual shutoff valve.
	Control knob not in PILOT position.	Turn control knob to PILOT position.
	Control knob not pressed in while in PILOT position.	Press in control knob while in PILOT position.
	Air in gas lines when installed.	Continue holding down control knob. Repeat igniting operation until air is removed.
	ODS/pilot is clogged.	Replace ODS/pilot assembly or get it serviced.
	Gas regulator setting is not correct.	Check incoming pressure. Replace gas regulator.

With proper installation, operation, and maintenance your gas appliance will provide years of trouble-free service. If you do experience a problem, this troubleshooting guide will assist a qualified service technician in the diagnosis of a problem and the corrective action to be taken. This troubleshooting guide can only be used by a qualified service technician. Contact your dealer to arrange a service call by a qualified service technician.

B. IntelliFire™ Plus ODS Ignition System

Symptom	Possible Cause	Corrective Action
1. Pilot won't light. The ignitor/module makes noise, but no spark.	A. Incorrect wiring.	Verify "S" wire (white) for sensor and "I" wire (orange) for ignitor are connected to correct terminals on module and pilot assembly.
	B. Loose connections or electrical shorts in the wiring.	Verify no loose connections or electrical shorts in wiring from module to pilot assembly. Verify connections underneath pilot assembly are tight; also verify igniter and flame sense wires are not grounding out to metal chassis, pilot burner, pilot enclosure, mesh screen if present, or any other metal object.
	C. Ignitor gap is too large.	Verify gap of ignitor to thermocouple (natural gas models) or ignitor to pilot barrel (propane models). The gap should be approximately .095 in. (2.41 mm) to .135 in. (3.43 mm).
2. Pilot won't light, there is no noise or spark.	A. Depleted batteries or batteries installed incorrectly.	Battery power supply voltage must be at least 4.9 volts. If less than 4.9 volts, replace batteries.
	B. A shorted or loose connection in wiring configuration or wiring harness.	Remove and reinstall the wiring harness that plugs into module. Verify there is a tight fit. Verify pilot assembly wiring to module. Remove and verify continuity of each wire in wiring harness. Replace any damaged components.
	C. Improper wall switch wiring.	Verify that 110-120 VAC power is "ON" to junction box.
	D. Module not grounded.	Verify black ground wire from module wire harness is grounded to metal chassis of appliance.
3. Pilot sparks, but pilot will not light.	A. Gas supply is off or lacking pressure.	Verify that incoming gas line ball valve is "open." Verify that inlet pressure reading is within acceptable limits.
	B. Ignitor gap is too large.	Verify gap of ignitor to thermocouple (natural gas models) or ignitor to pilot barrel (propane models). The gap should be approximately .095 in. (2.41 mm) to .135 in. (3.43 mm).
	C. Module is not grounded.	Verify module is securely grounded to metal chassis of appliance.
	D. Pilot valve solenoid voltage is out of spec.	Verify that 1.5 to 1.8 VDC is supplied to pilot solenoid from module. If below 1.5 volts, replace module. If 1.5 volts or greater, replace valve.
4. Shortened battery life	A. Thermopile wires hooked up backwards	Verify white and red wires from thermopile are in correct location on control module.
	B. Using flame adjustment feature frequently on the RC300	Battery life will be shortened if the flame adjustment feature is used frequently on the RC300 remote control. Reduce the number of times flame height is adjusted to increase battery life.

Intellifire™ Plus Ignition System - (continued)

Symptom	Possible Cause	Corrective Action
5. Pilot lights but continues to spark, and main burner will not ignite. (If the pilot continues to spark after the pilot flame has been lit, flame rectification has not occurred.)	A. A shorted or loose connection from thermocouple or thermocouple module.	Verify all connections to wiring diagram in manual. Verify connections underneath pilot assembly are tight. Verify flame sense or igniter wires are not grounding out to metal chassis, pilot burner, pilot enclosure or screen if present, or any other metal object.
	B. Poor flame rectification or contaminated flame sensing rod.	Verify correct pilot orifice is installed and gas inlet is set to pressure specifications. Check pilot for soot. Clean if necessary. Polish flame sensing rod with fine steel wool to remove any contaminants that may have accumulated on flame sensing rod.
	C. Module is not grounded.	Verify module is securely grounded to metal chassis of appliance. Verify that wire harness is firmly connected to the module.
	D. Damaged pilot assembly or contaminated thermocouple.	Verify connection from thermocouple to thermocouple module, check thermocouple for contaminants. Clean if necessary. Replace pilot if any damage is detected.

14 Service Parts

► A. Service Parts



Service Parts

NB18NV, NB18PV

18" Millivolt Hearth Kit

Beginning Manufacturing Date: NA
Ending Manufacturing Date: Active

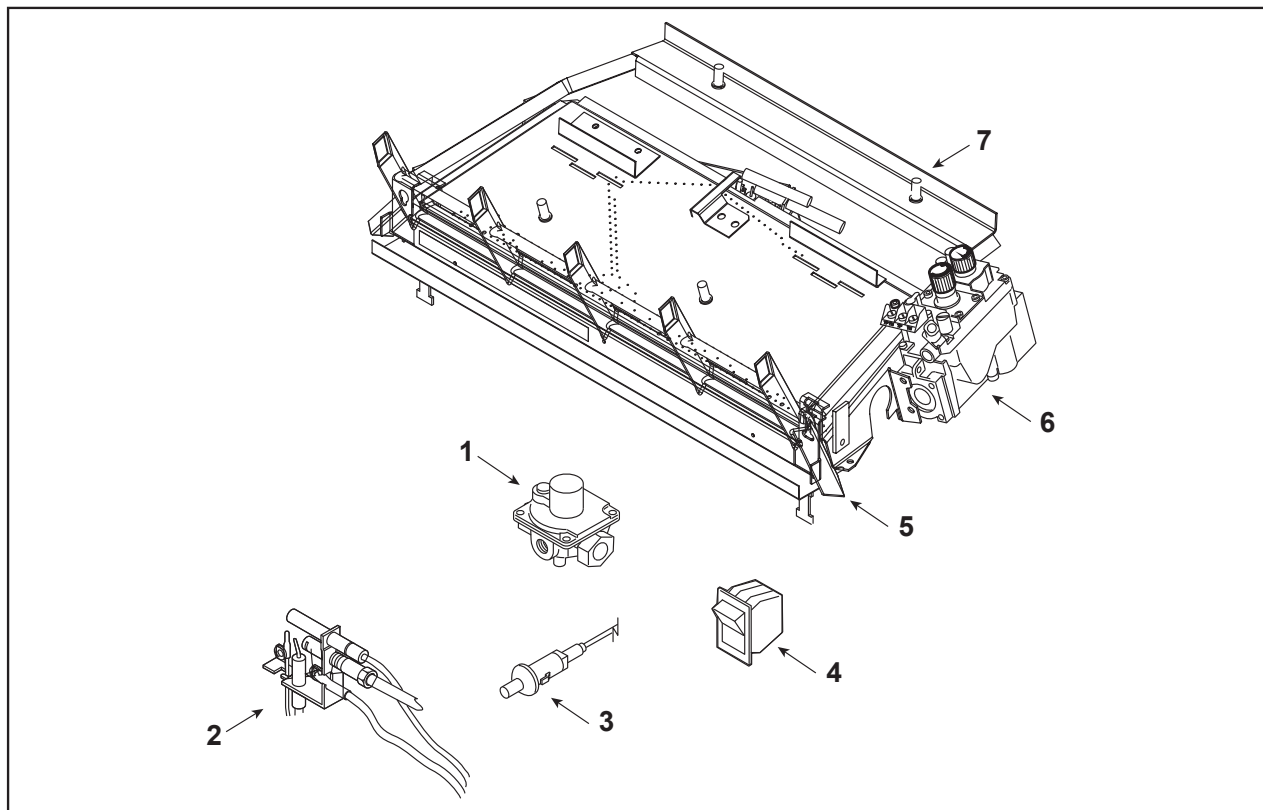

IMPORTANT: THIS IS DATED INFORMATION. Parts must be ordered from a dealer or distributor. **Hearth and Home Technologies does not sell directly to consumers.** Provide model number and serial number when requesting service parts from your dealer or distributor.



Stocked at Depot

ITEM	DESCRIPTION	COMMENTS	PART NUMBER	
1	Pilot Regulator	NG Only	SRV14D0469	Y
2	Pilot Assembly	NG	SRV14D0473	Y
		Propane	SRV14D0477	Y
3	Piezo Ignitor		SRV14D0503	Y
	Piezo Wire		SRV00K0632	Y
4	On/Off Switch		SRV32D0232	Y
5	Grate Assembly		20304325K	Y
6	Control Valve	NG	SRV14D0467	Y
		Propane	SRV14D0468	Y
7	Rear Log Bracket		81D2002K	
	Tubing, Regulator to Pilot	NG	44D0312K	
	Tubing, Pilot to Valve	Propane	81D2510K	Y
	Wiring Harness		SRV70D0050	Y
	Lava Rock	2.5lb	SRV00F0540	Y
	Rock Wool	2 grams	SRV81D2011	Y

11/19



Service Parts

NB24NV, NB24PV

24" Millivolt Hearth Kit

Beginning Manufacturing Date: NA
Ending Manufacturing Date: Active

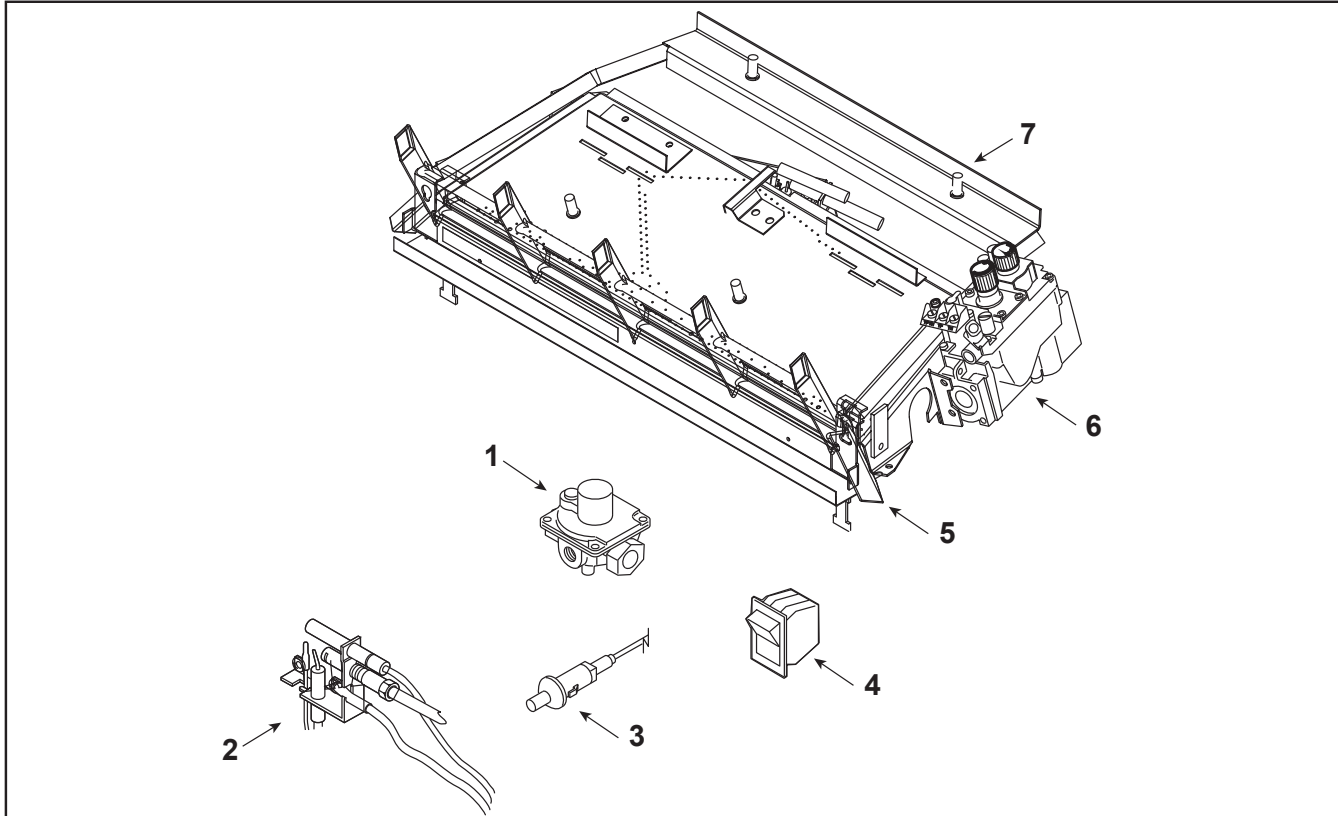

IMPORTANT: THIS IS DATED INFORMATION. Parts must be ordered from a dealer or distributor. **Hearth and Home Technologies does not sell directly to consumers.** Provide model number and serial number when requesting service parts from your dealer or distributor.



Stocked at Depot

ITEM	DESCRIPTION	COMMENTS	PART NUMBER	Stocked at Depot
1	Pilot Regulator	NG Only	SRV14D0469	Y
2	Pilot Assembly	NG	SRV14D0473	Y
		Propane	SRV14D0477	Y
3	Piezo Ignitor		SRV14D0503	Y
	Piezo Wire		SRV00K0632	Y
4	On/Off Switch		SRV32D0232	Y
5	Grate Assembly		20302502K	Y
6	Control Valve	NG	SRV14D0467	Y
		Propane	SRV14D0468	Y
7	Rear Log Bracket		81D2002K	
	Tubing, Regulator to Pilot	NG	44D0312K	
	Tubing, Regulator to Valve	NG	81D0111K	
	Tubing, Pilot to Valve	Propane	81D2510K	Y
	Wiring Harness		SRV70D0050	Y
	Lava Rock	2.5lb	SRV00F0540	Y
	Rock Wool	3 grams	SRV59D0111	Y

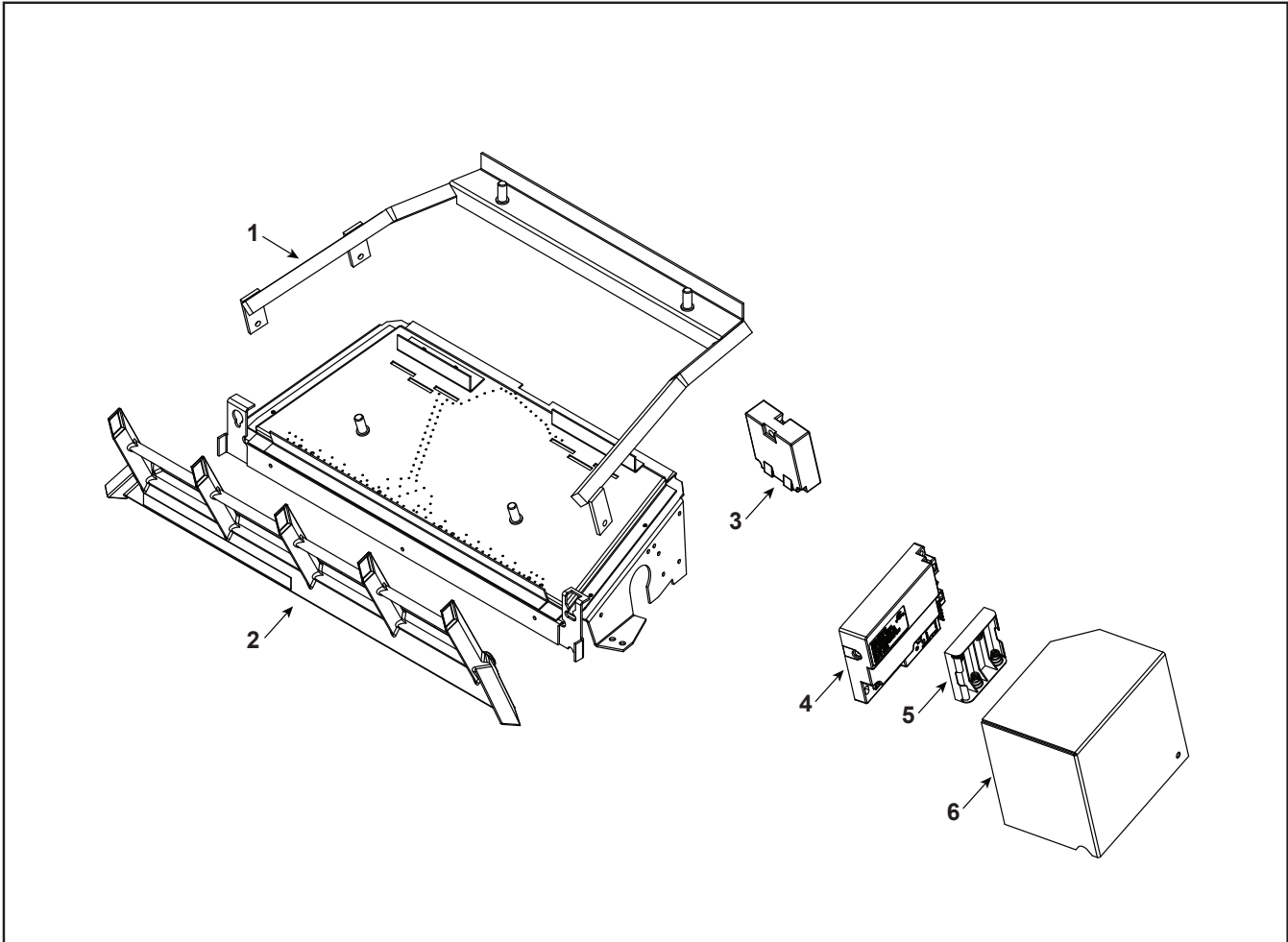

IMPORTANT: THIS IS DATED INFORMATION. Parts must be ordered from a dealer or distributor. **Hearth and Home Technologies does not sell directly to consumers.** Provide model number and serial number when requesting service parts from your dealer or distributor.



Stocked at Depot

ITEM	DESCRIPTION	COMMENTS	PART NUMBER	
1	Weldment, Grate		81D2002K	
2	Grate Assembly		20304325K	
3	Thermocouple Module		SRV20303179	Y
4	Control Module		SRV4018-069	Y
5	Battery Pack		SRV4018-323	Y
6	Component Cover		20302870K	
	Wire Assembly		SRV00k0632	Y
	Wire, Thermocouple Module		SRV20301890	Y
	Lava Rock	2.5 .lbs	SRV00F0540	Y
	Rock Wool	2 grams	SRV81D2011	Y

Additional service part numbers appear on following page.

11/19

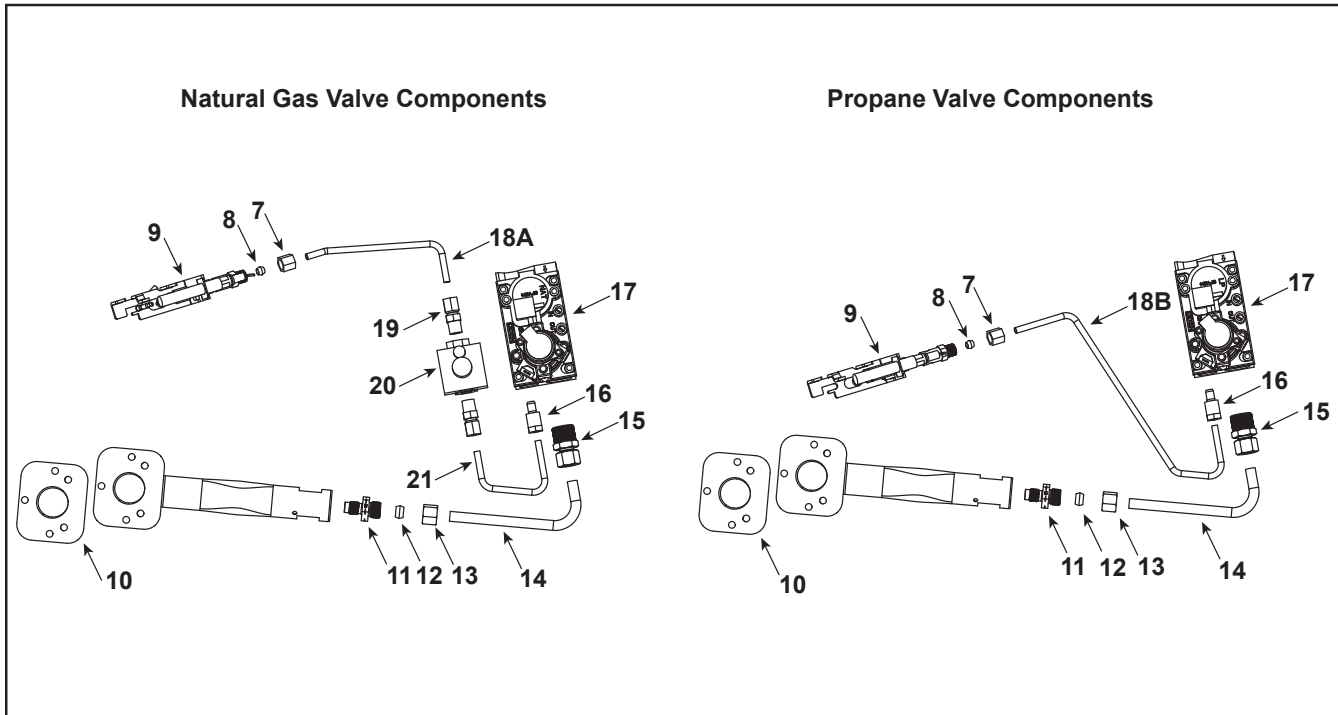

IMPORTANT: THIS IS DATED INFORMATION. Parts must be ordered from a dealer or distributor. **Hearth and Home Technologies does not sell directly to consumers.** Provide model number and serial number when requesting service parts from your dealer or distributor.



Stocked at Depot

ITEM	DESCRIPTION	COMMENTS	PART NUMBER	
7	Nut, 3/8-24 UNF 3/16 Tube		SRV00F0077	
8	Ferrule, 3/16 Tube		SRV00F0078	
9	Pilot ODS	NG	SRV14D0473	Y
		Propane	SRV14D0477	Y
10	Venturi Gasket		SRV45D0032	Y
11	Injector	NG (#38)	SRV33D5040	
		Propane (#52)	SRV58D0052	
12	Ferrule, 5/16 Tube		SRV00K0918	
13	Nut, 1/2-24 UNF 5/16 Tube		SRV00K0917	
14	Tube, 5/16 Valve to Burner		SRV4619-150	
15	Fitting, 5/16 Tube x 3/8 MPT		SRV11V0313	
16	Fitting, 3/16 Tube x 7/16-24 UNS		SRV71076	
17	Valve	NG	SRV4018-047	Y
		Propane	SRV4018-048	Y
18A	Tube, 3/16 Regulator to Pilot	NG	SRV4619-152	
18B	Tube, 3/16 Valve to Pilot	Propane	SRV4619-161	
19	Fitting, 3/16 Tube x 1/8 MPT	NG (Qty 2 req)	SRV20H0109	Y
20	Pilot Regulator	NG	SRV14D0469	Y
21	Tube, 3/16 Valve to Regulator	NG	SRV4619-151	

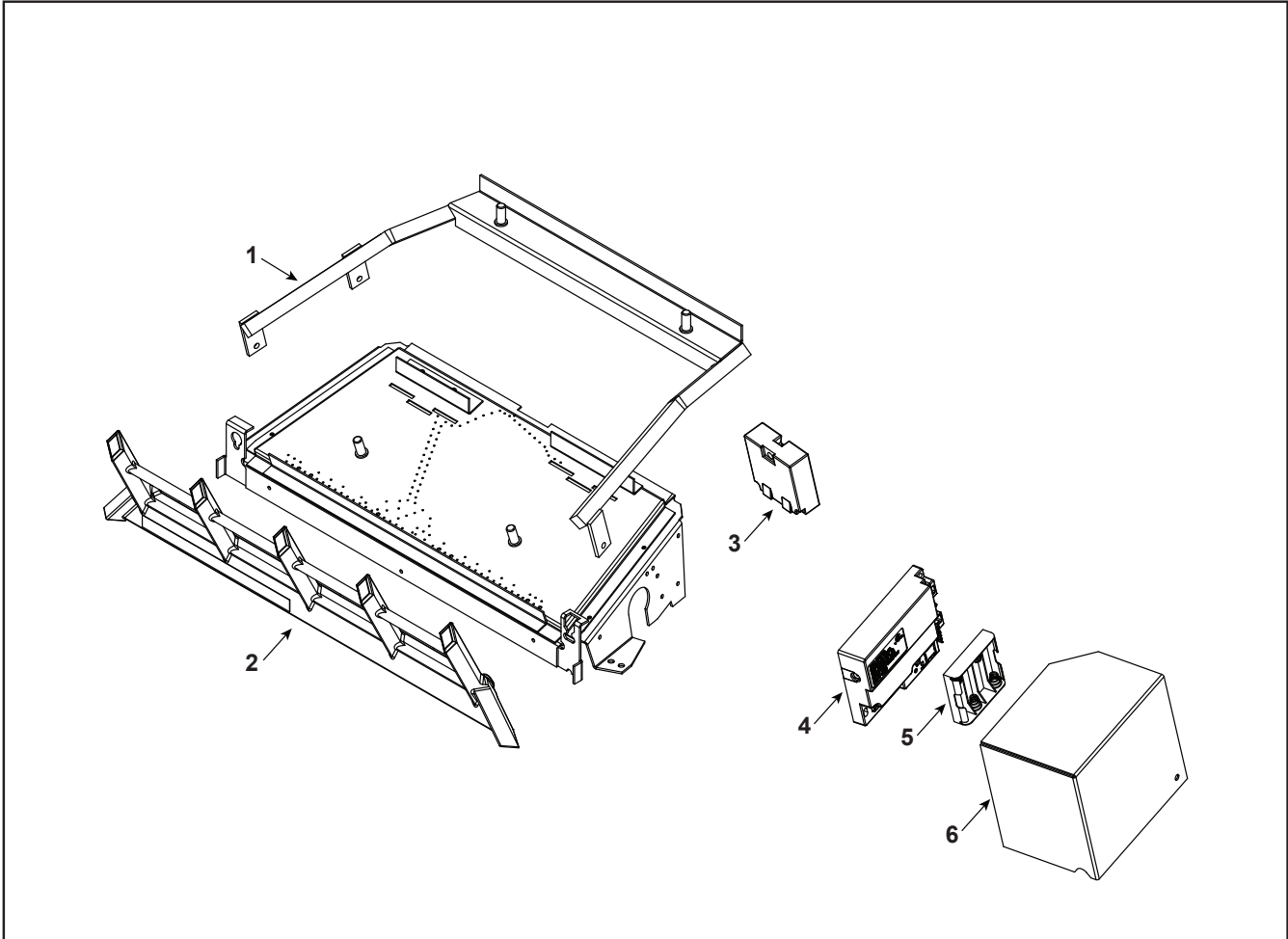

IMPORTANT: THIS IS DATED INFORMATION. Parts must be ordered from a dealer or distributor. **Hearth and Home Technologies does not sell directly to consumers.** Provide model number and serial number when requesting service parts from your dealer or distributor.



Stocked at Depot

ITEM	DESCRIPTION	COMMENTS	PART NUMBER	
1	Weldment, Grate		81D0502K	
2	Grate Assembly		20302502K	
3	Thermocouple Module		SRV20303179	Y
4	Control Module		SRV4018-069	Y
5	Battery Pack		SRV4018-323	Y
6	Component Cover		20302870K	
	Wire Assembly		SRV4604-304	Y
	Wire, Thermocouple Module		SRV20301890	Y
	Lava Rock	2.5 .lbs	SRV00F0540	Y
	Rock Wool	3 grams	SRV59D0111	Y

Additional service part numbers appear on following page.

11/19

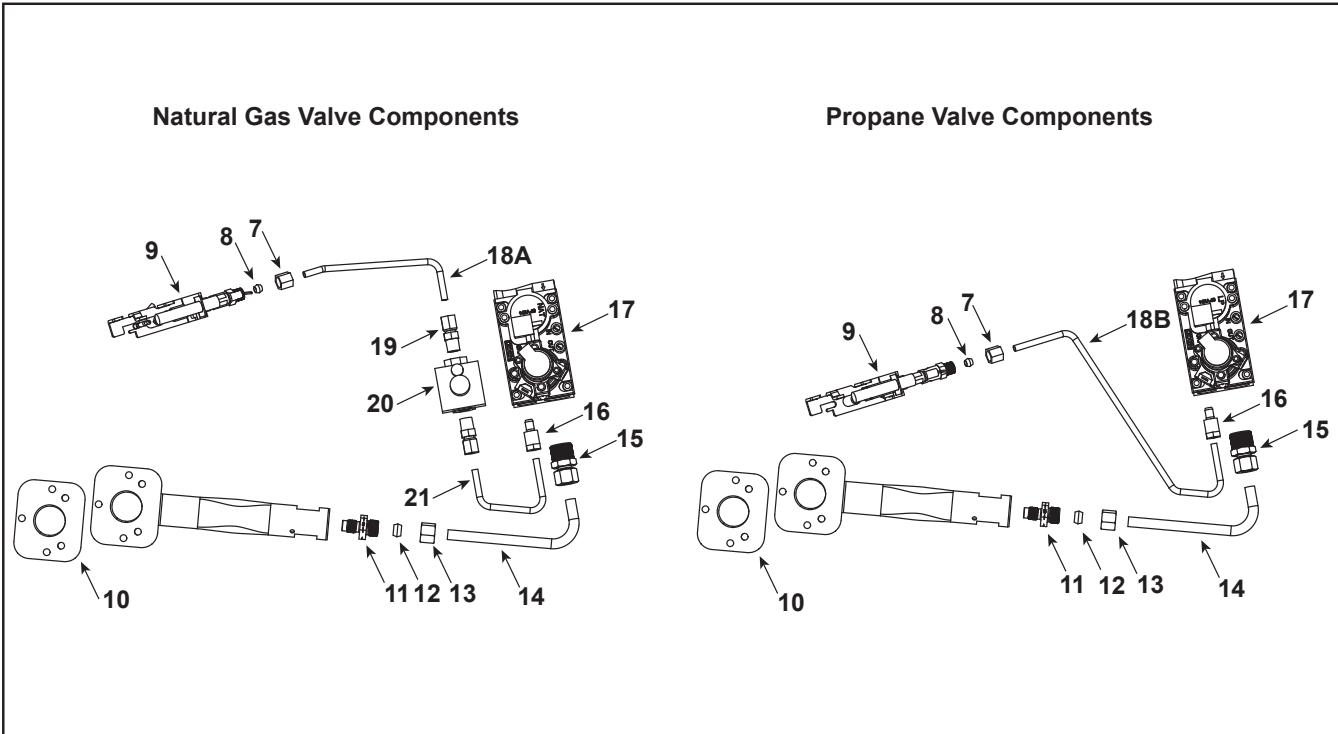

IMPORTANT: THIS IS DATED INFORMATION. Parts must be ordered from a dealer or distributor. **Hearth and Home Technologies does not sell directly to consumers.** Provide model number and serial number when requesting service parts from your dealer or distributor.



Stocked at Depot

ITEM	DESCRIPTION	COMMENTS	PART NUMBER	
7	Nut, 3/8-24 UNF 3/16 Tube		SRV00F0077	
8	Ferrule, 3/16 Tube		SRV00F0078	
9	Pilot ODS	NG	SRV14D0473	Y
		Propane	SRV14D0477	Y
10	Venturi Gasket		SRV45D0032	Y
11	Injector	NG (3.00mm)	SRV20H3154	Y
		Propane (#49)	SRV57D0612	Y
12	Ferrule, 5/16 Tube		SRV00K0918	
13	Nut, 1/2-24 UNF 5/16 Tube		SRV00K0917	
14	Tube, 5/16 Valve to Burner		SRV4620-150	
15	Fitting, 5/16 Tube x 3/8 MPT		SRV11V0313	
16	Fitting, 3/16 Tube x 7/16-24 UNS		SRV71076	
17	Valve	NG	SRV4018-047	Y
		Propane	SRV4018-048	Y
18A	Tube, 3/16 Regulator to Pilot	NG	SRV4620-152	
18B	Tube, 3/16 Valve to Pilot	Propane	SRV4620-161	
19	Fitting, 3/16 Tube x 1/8 MPT	NG (Qty 2 req)	SRV20H0109	Y
20	Pilot Regulator	NG	SRV14D0469	Y
21	Tube, 3/16 Valve to Regulator	NG	SRV4619-151	

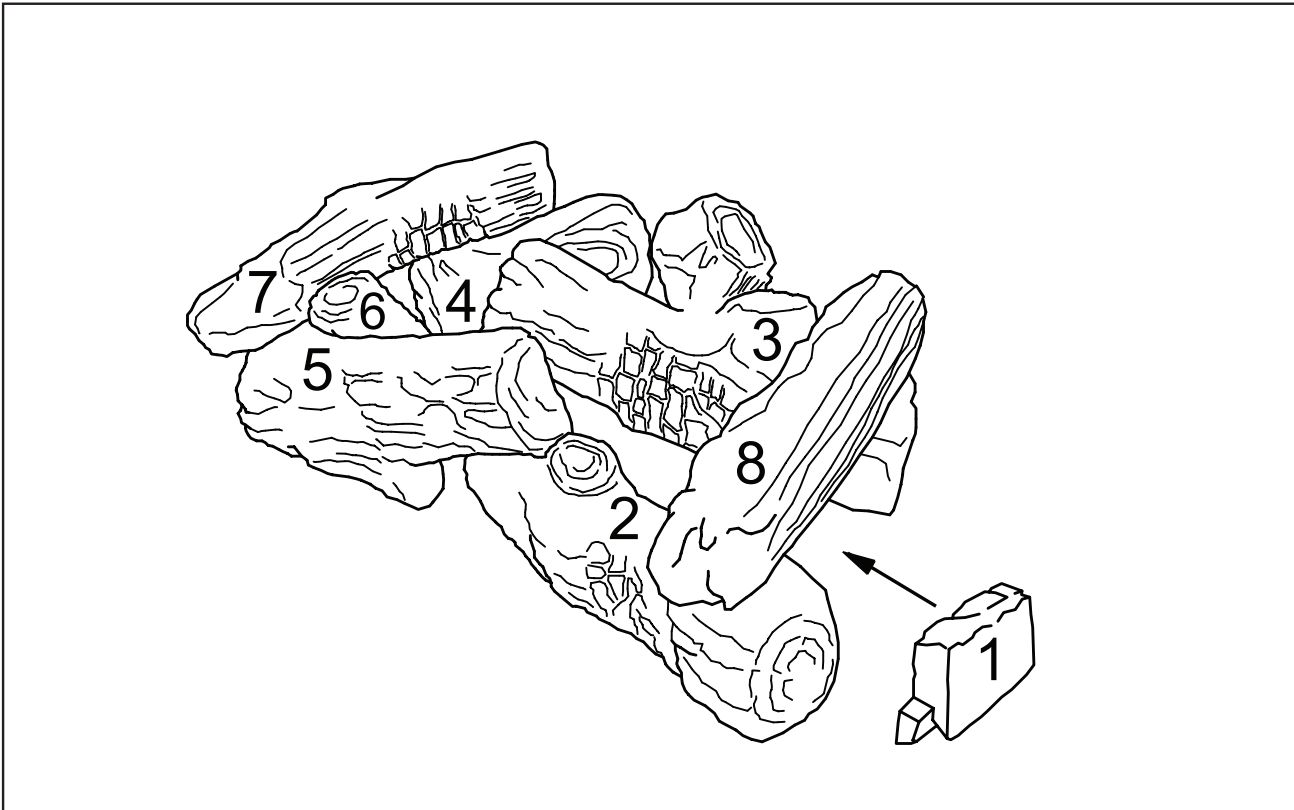

IMPORTANT: THIS IS DATED INFORMATION. Parts must be ordered from a dealer or distributor. **Hearth and Home Technologies does not sell directly to consumers.** Provide model number and serial number when requesting service parts from your dealer or distributor.



Stocked at Depot

ITEM	DESCRIPTION	COMMENTS	PART NUMBER	
1	Ember Chunk	BO18-R	81D0110K	
		BO18-F	81D0109K	
2	Right Front Log	BO18-R	81D0059K	
		BO18-F	81D0083K	
3	Right Rear Log	BO18-R	81D0060K	
		BO18-F	81D0084K	
4	Left Rear Log	BO18-R	81D0061K	
		BO18-F	81D0085K	
5	Left Front Log	BO18-R	81D0092K	
		BO18-F	81D0086K	
6	Middle Left Log	BO18-R	81D0063K	
		BO18-F	81D0087K	
7	Left Top Log	BO18-R	81D0064K	
		BO18-F	81D0088K	
8	Right Top Log	BO18-R	81D0065K	
		BO18-F	81D0089K	

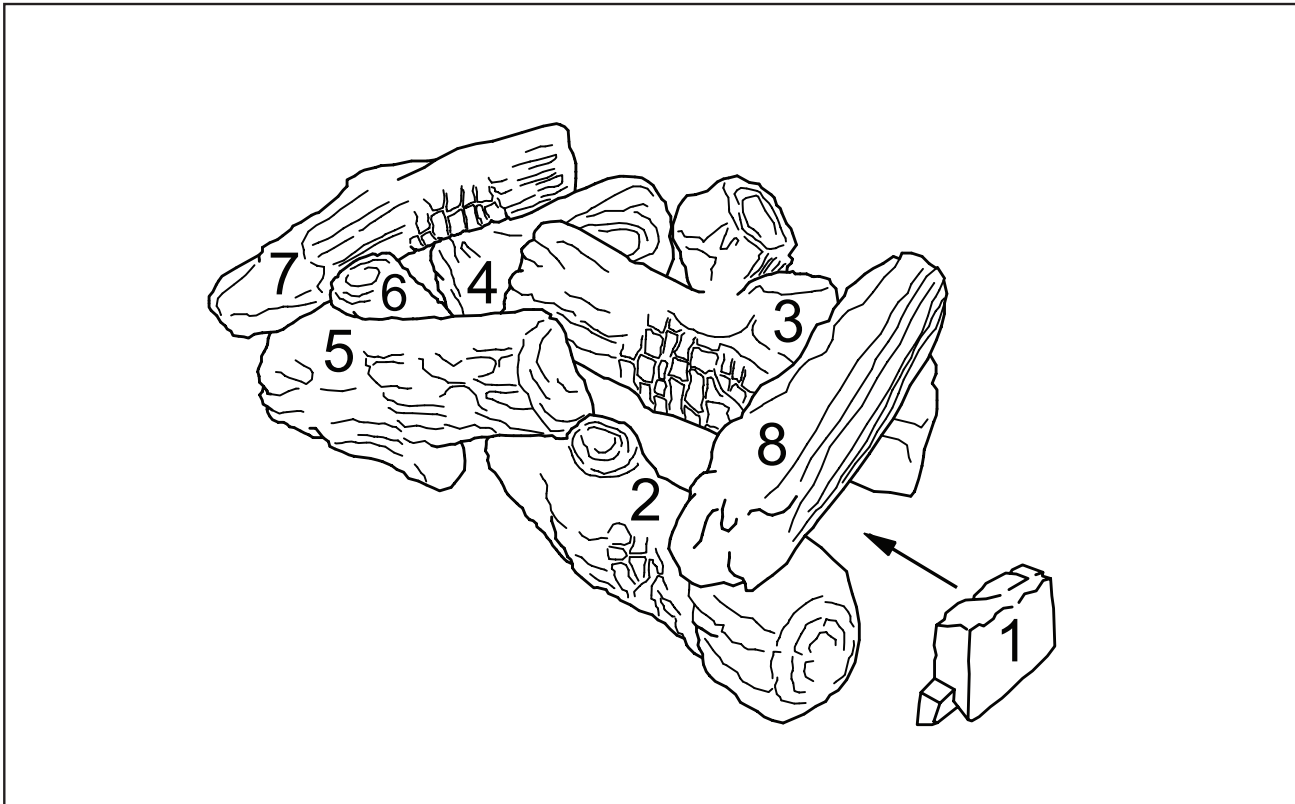

IMPORTANT: THIS IS DATED INFORMATION. Parts must be ordered from a dealer or distributor. **Hearth and Home Technologies does not sell directly to consumers.** Provide model number and serial number when requesting service parts from your dealer or distributor.

Stocked at Depot

ITEM	DESCRIPTION	COMMENTS	PART NUMBER	
1	Ember Chunk	BO24-R	81D0110K	
		BO24-F	81D0109K	
2	Right Front Log	BO24-R	81D0067K	
		BO24-F	81D0091K	
3	Right Rear Log	BO24-R	81D0068K	
		BO24-F	81D0092K	
4	Left Rear Log	BO24-R	81D0069K	
		BO24-F	81D0093K	
5	Left Front Log	BO24-R	81D0070K	
		BO24-F	81D0094K	
6	Middle Left Log	BO24-R	81D0071K	
		BO24-F	81D0095K	
7	Left Top Log	BO24-R	81D0072K	
		BO24-F	81D0096K	
8	Right Top Log	BO24-R	81D0073K	
		BO24-F	81D0097K	

11/19

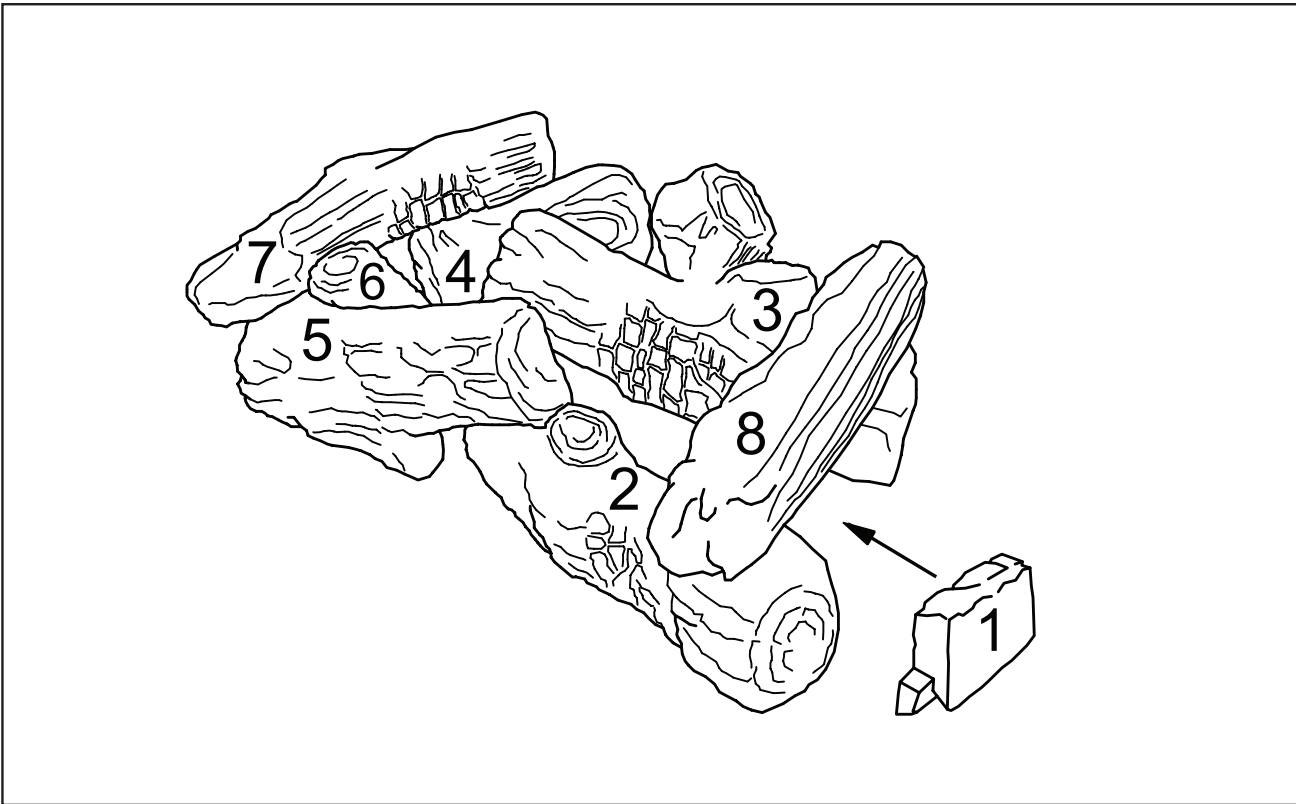

IMPORTANT: THIS IS DATED INFORMATION. Parts must be ordered from a dealer or distributor. **Hearth and Home Technologies does not sell directly to consumers.** Provide model number and serial number when requesting service parts from your dealer or distributor.



Stocked at Depot

ITEM	DESCRIPTION	COMMENTS	PART NUMBER	
1	Ember Chunk	BO30-R	81D0110K	
		BO30-F	81D0109K	
2	Right Front Log	BO30-R	81D0075K	
		BO30-F	81D0099K	
3	Right Rear Log	BO30-R	81D0076K	
		BO30-F	81D0100K	
4	Left Rear Log	BO30-R	81D0077K	
		BO30-F	81D0101K	
5	Left Front Log	BO30-R	81D0078K	
		BO30-F	81D0102K	
6	Middle Left Log	BO30-R	81D0071K	
		BO30-F	81D0095K	
7	Left Top Log	BO30-R	81D0072K	
		BO30-F	81D0096K	
8	Right Top Log	BO30-R	81D0073K	
		BO30-F	81D0094K	

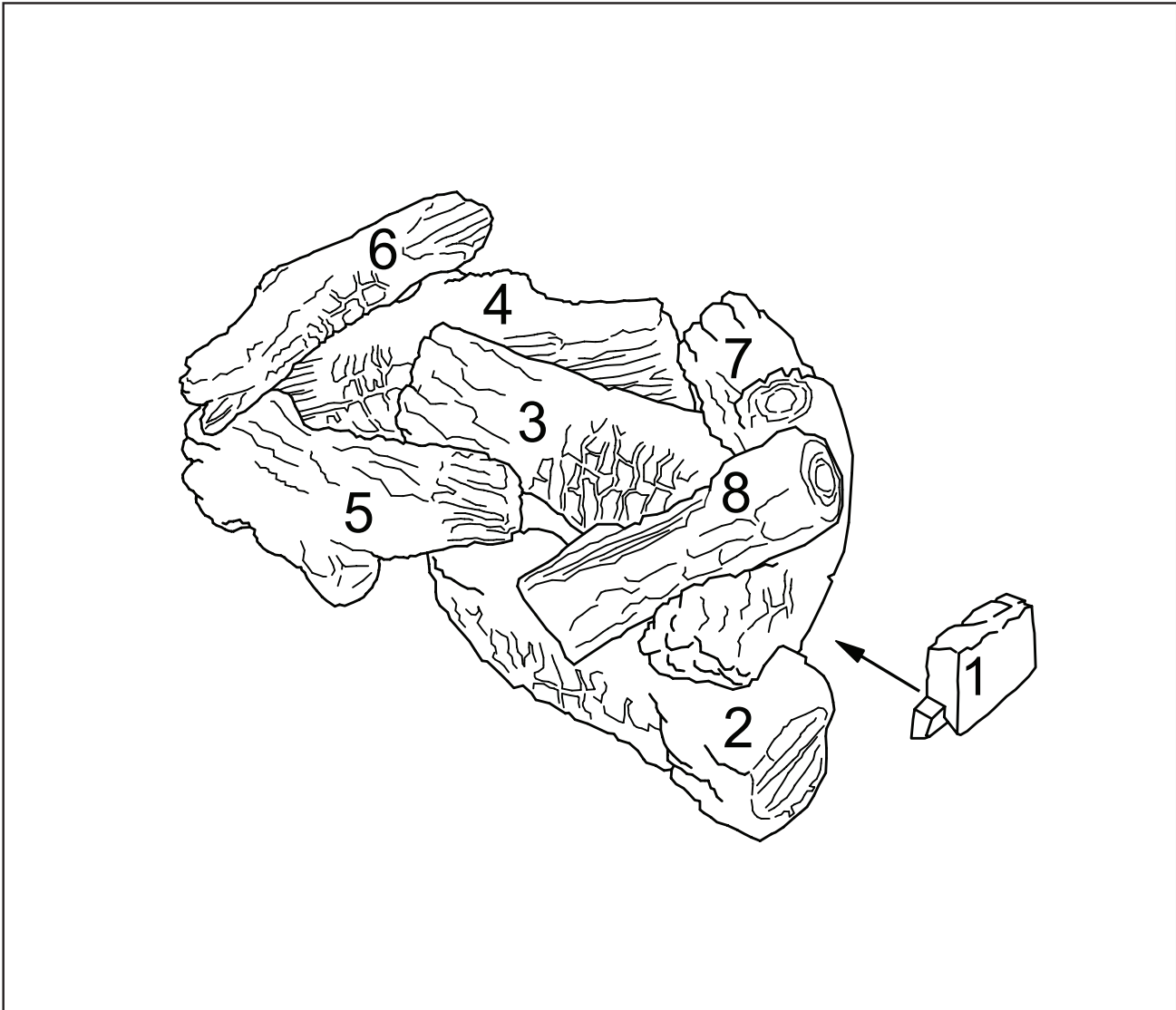

IMPORTANT: THIS IS DATED INFORMATION. Parts must be ordered from a dealer or distributor. **Hearth and Home Technologies does not sell directly to consumers.** Provide model number and serial number when requesting service parts from your dealer or distributor.

Stocked at Depot

ITEM	DESCRIPTION	COMMENTS	PART NUMBER
1	Ember Chunk		81D0110K
2	Right Front Bottom Log		81D0011K
3	Right Rear Log		81D0012K
4	Left Rear Log		81D0013K
5	Left Front Log		81D0014K
6	Left Top Log		81D0015K
7	Right Top Log		81D0016K
8	Right Front Log		81D0017K

11/19

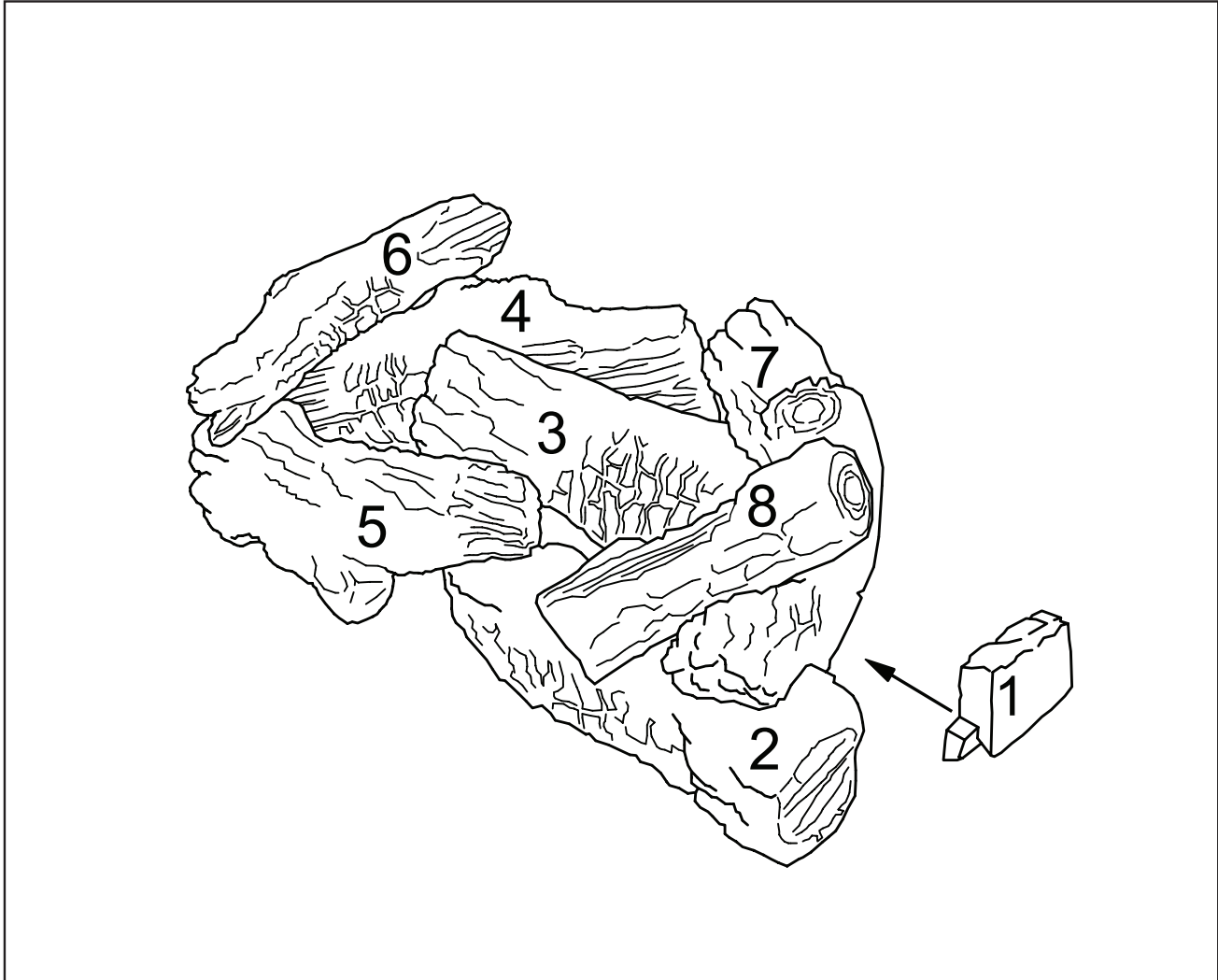

IMPORTANT: THIS IS DATED INFORMATION. Parts must be ordered from a dealer or distributor. **Hearth and Home Technologies does not sell directly to consumers.** Provide model number and serial number when requesting service parts from your dealer or distributor.

Stocked at Depot

ITEM	DESCRIPTION	COMMENTS	PART NUMBER	
1	Ember Chunk		81D0110K	
2	Right Front Bottom Log		81D0019K	
3	Right Rear Log		81D0020K	
4	Left Rear Log		81D0021K	
5	Left Front Log		81D0022K	
6	Left Top Log		81D0023K	
7	Right Top Log		81D0024K	
8	Right Front Log		81D0025K	

11/19

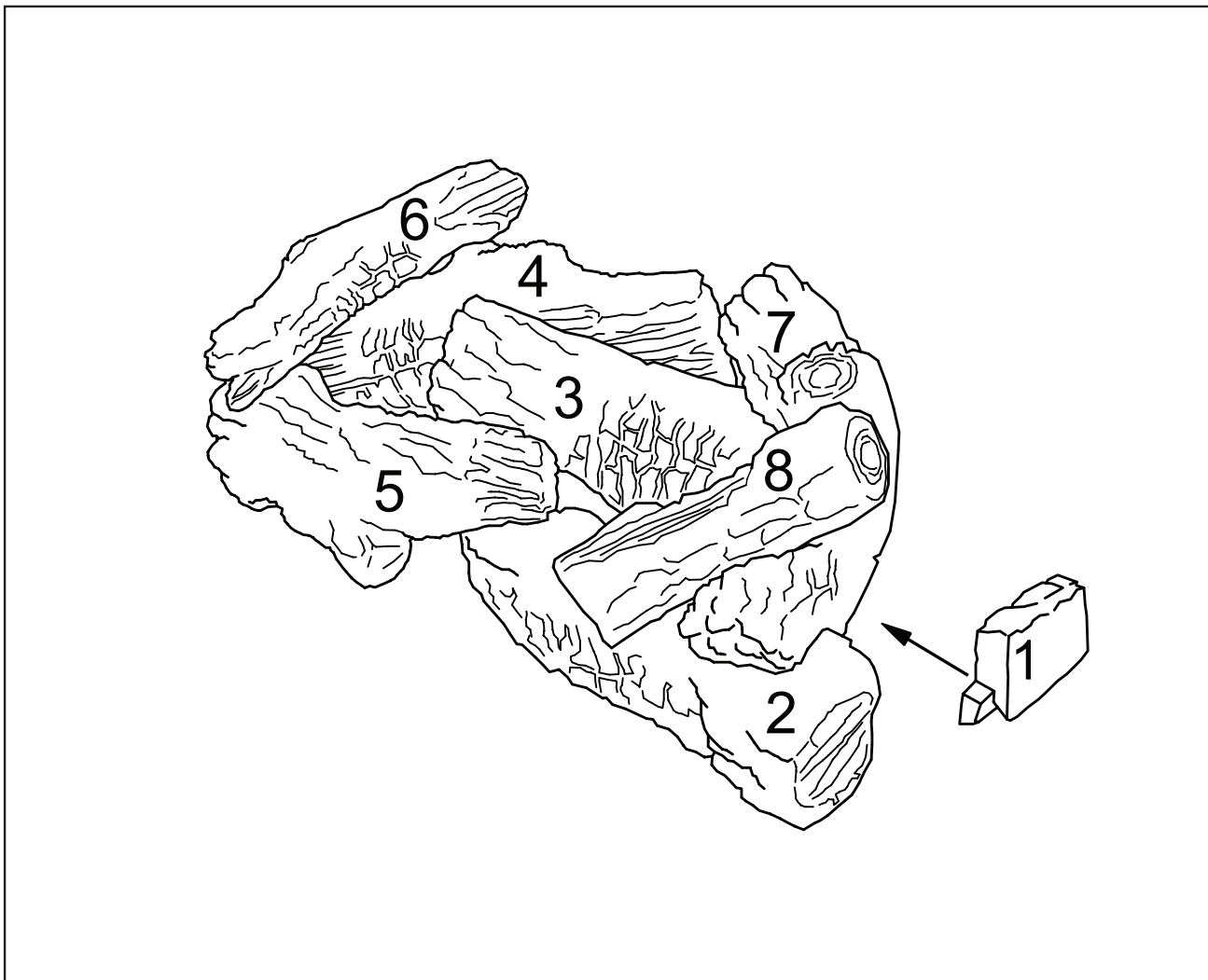

IMPORTANT: THIS IS DATED INFORMATION. Parts must be ordered from a dealer or distributor. **Hearth and Home Technologies does not sell directly to consumers.** Provide model number and serial number when requesting service parts from your dealer or distributor.



Stocked at Depot

ITEM	DESCRIPTION	COMMENTS	PART NUMBER	
1	Ember Chunk		81D0110K	
2	Right Front Bottom Log		81D0027K	
3	Right Rear Log		81D0028K	
4	Left Rear Log		81D0029K	
5	Left Front Log		81D0030K	
6	Left Top Log		81D0023K	
7	Right Top Log		81D0024K	
8	Right Front Log		81D0025K	

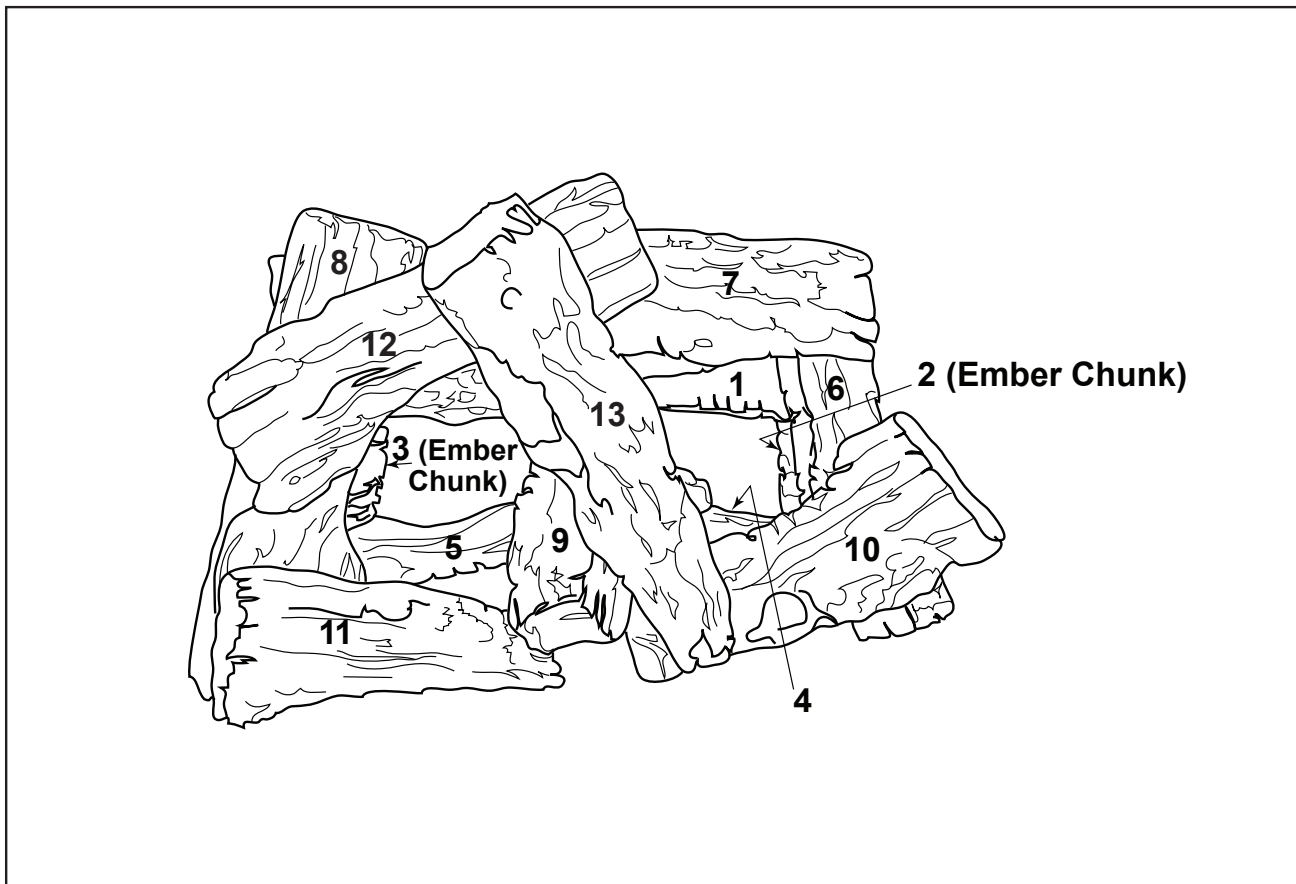

IMPORTANT: THIS IS DATED INFORMATION. Parts must be ordered from a dealer or distributor. **Hearth and Home Technologies does not sell directly to consumers.** Provide model number and serial number when requesting service parts from your dealer or distributor.

Stocked at Depot

ITEM	DESCRIPTION	COMMENTS	PART NUMBER	
1	Bottom Rear Log		20303558K	
2	Ember Chunk (notch on both ends)		81D0110K	
3	Ember Chunk (notch on one end)		81D0110K	
4	Front Bottom Right Log		20303560K	
5	Front Bottom Left Log		20303561K	
6	Mid Right Log		20303562K	
7	Mid Rear Log		20303563K	
8	Mid Left Log		20303564K	
9	Center Log		20303565K	
10	Top Front Right Log		20303566K	
11	Top Front Left Log		20303567K	
	Enhancement Kit		SC18EK	
12	Enhancement Front Log		20303568K	
13	Enhancement Top Log		20303569K	

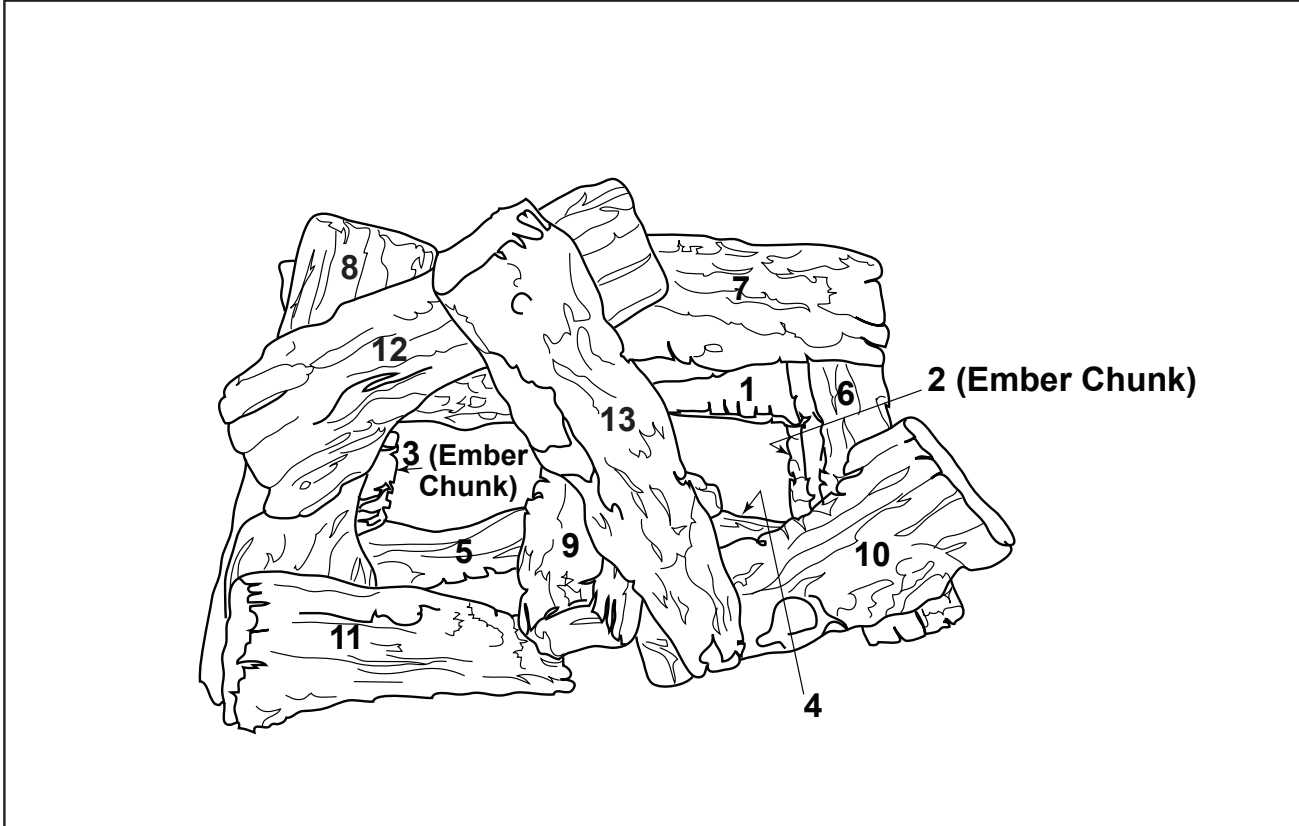

IMPORTANT: THIS IS DATED INFORMATION. Parts must be ordered from a dealer or distributor. **Hearth and Home Technologies does not sell directly to consumers.** Provide model number and serial number when requesting service parts from your dealer or distributor.



Stocked at Depot

ITEM	DESCRIPTION	COMMENTS	PART NUMBER	
1	Bottom Rear Log		20303570K	
2	Ember Chunk (notch on both ends)		81D0110K	
3	Ember Chunk (notch on one end)		20303559K	
4	Front Bottom Right Log		20303571K	
5	Front Bottom Left Log		20303572K	
6	Mid Right Log		20303573K	
7	Mid Rear Log		20303574K	
8	Mid Left Log		20303575K	
9	Center Log		20303576K	
10	Top Front Right Log		20303577K	
11	Top Front Left Log		20303578K	
	Enhancement Kit		SC2430EK	
12	Enhancement Front Log		20303579K	
13	Enhancement Top Log		20303580K	

11/19

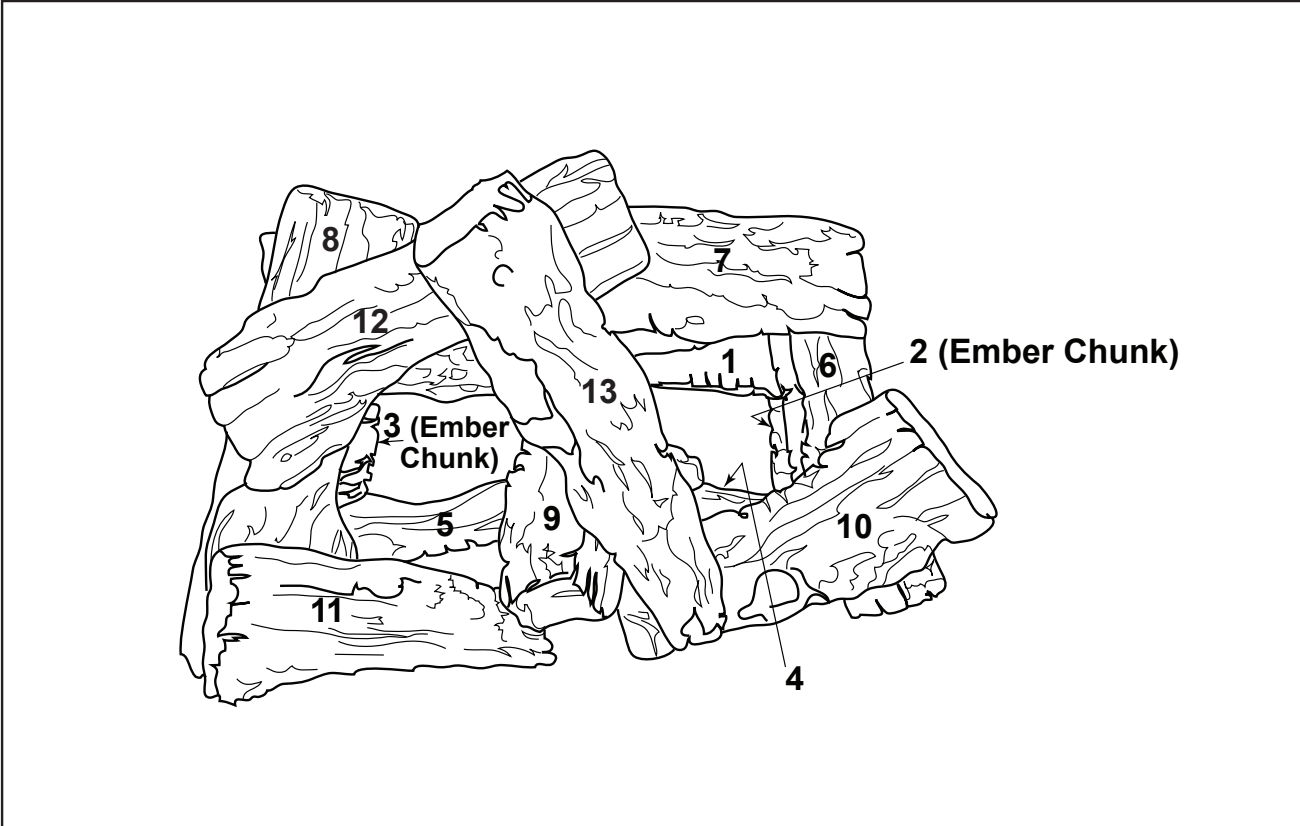

IMPORTANT: THIS IS DATED INFORMATION. Parts must be ordered from a dealer or distributor. **Hearth and Home Technologies does not sell directly to consumers.** Provide model number and serial number when requesting service parts from your dealer or distributor.



Stocked at Depot

ITEM	DESCRIPTION	COMMENTS	PART NUMBER
1	Bottom Rear Log		20303570K
2	Ember Chunk (notch on both ends)		81D0110K
3	Ember Chunk (notch on one end)		20303559K
4	Front Bottom Right Log		20303943K
5	Front Bottom Left Log		20303944K
6	Mid Right Log		20303573K
7	Mid Rear Log		20303574K
8	Mid Left Log		20303945K
9	Center Log		20303576K
10	Top Front Right Log		20303946K
11	Top Front Left Log		20303578K
	Enhancement Kit		SC2430EK
12	Enhancement Front Log		20303579K
13	Enhancement Top Log		20303580K

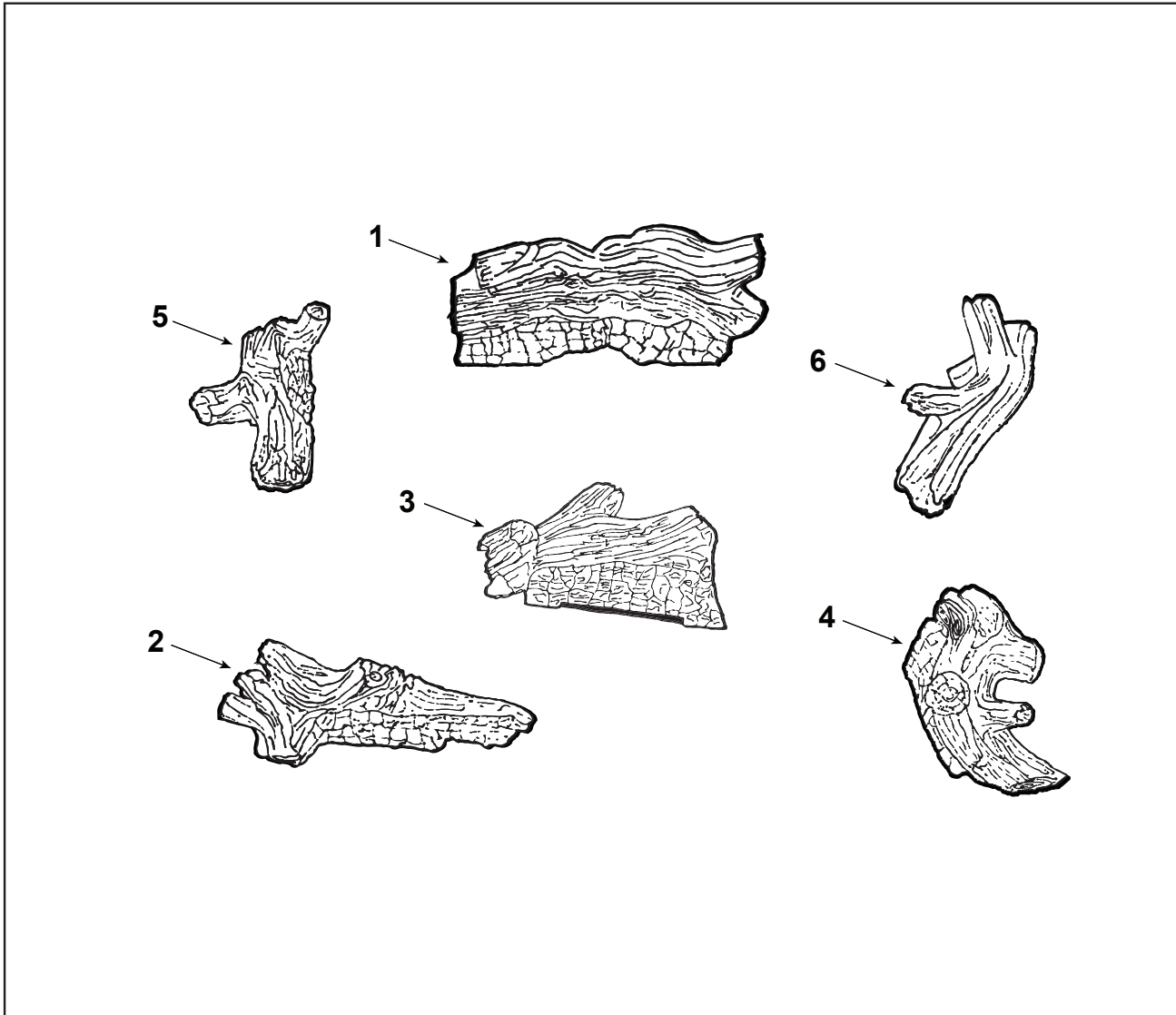

IMPORTANT: THIS IS DATED INFORMATION. Parts must be ordered from a dealer or distributor. **Hearth and Home Technologies does not sell directly to consumers.** Provide model number and serial number when requesting service parts from your dealer or distributor.



Stocked at Depot

ITEM	DESCRIPTION	COMMENTS	PART NUMBER
1	Rear Log		20308895
2	Front Left Log		20308897
3	Front Center Log		20308896
4	Right Log		20308752
5	Top Left Log		20308451
6	Center Top Log		20308900

11/19

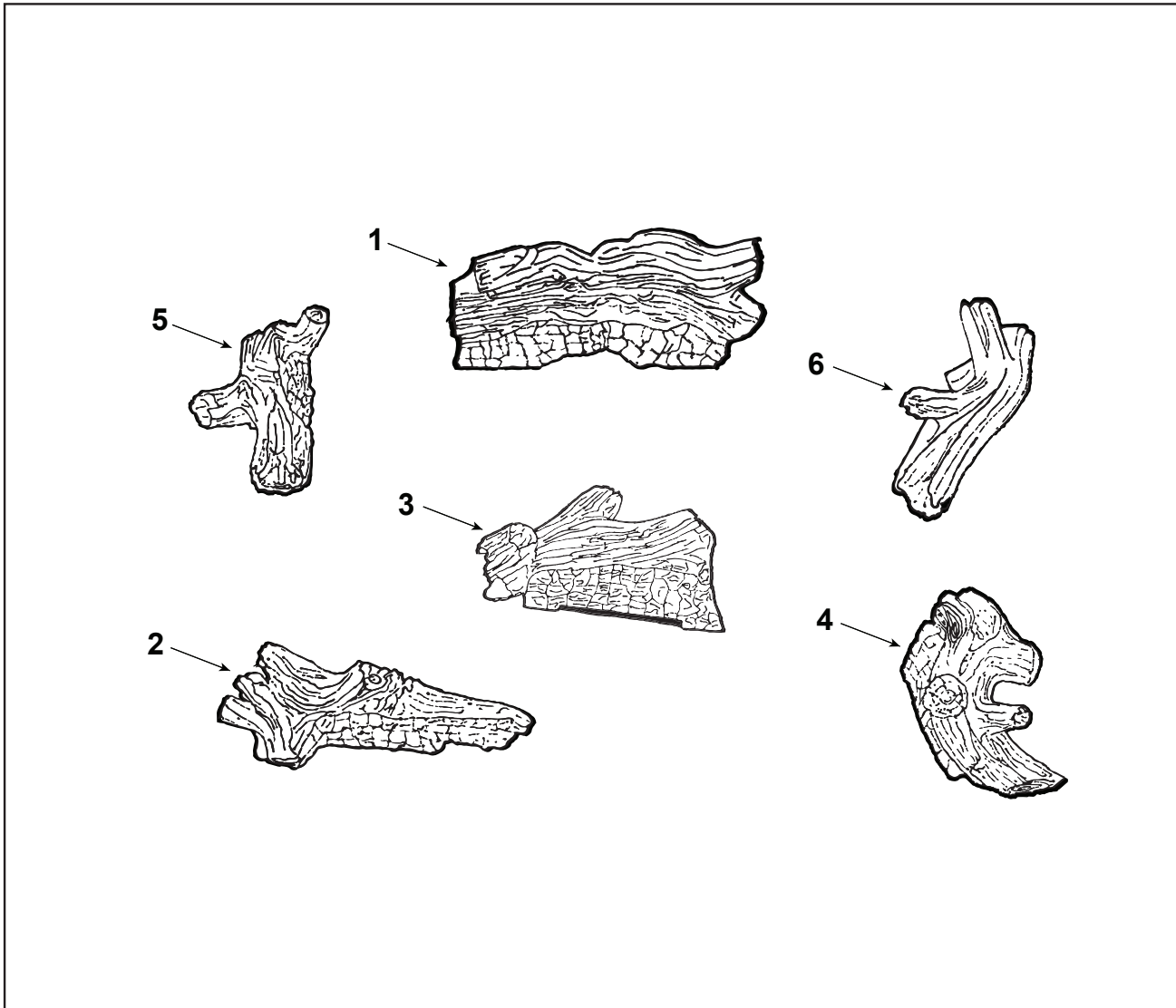

IMPORTANT: THIS IS DATED INFORMATION. Parts must be ordered from a dealer or distributor. **Hearth and Home Technologies does not sell directly to consumers.** Provide model number and serial number when requesting service parts from your dealer or distributor.



Stocked at Depot

ITEM	DESCRIPTION	COMMENTS	PART NUMBER
1	Rear Log		20308748
2	Front Left Log		20308750
3	Front Center Log		20308749
4	Right Log		20308752
5	Top Left Log		20308751
6	Center Top Log		20308753

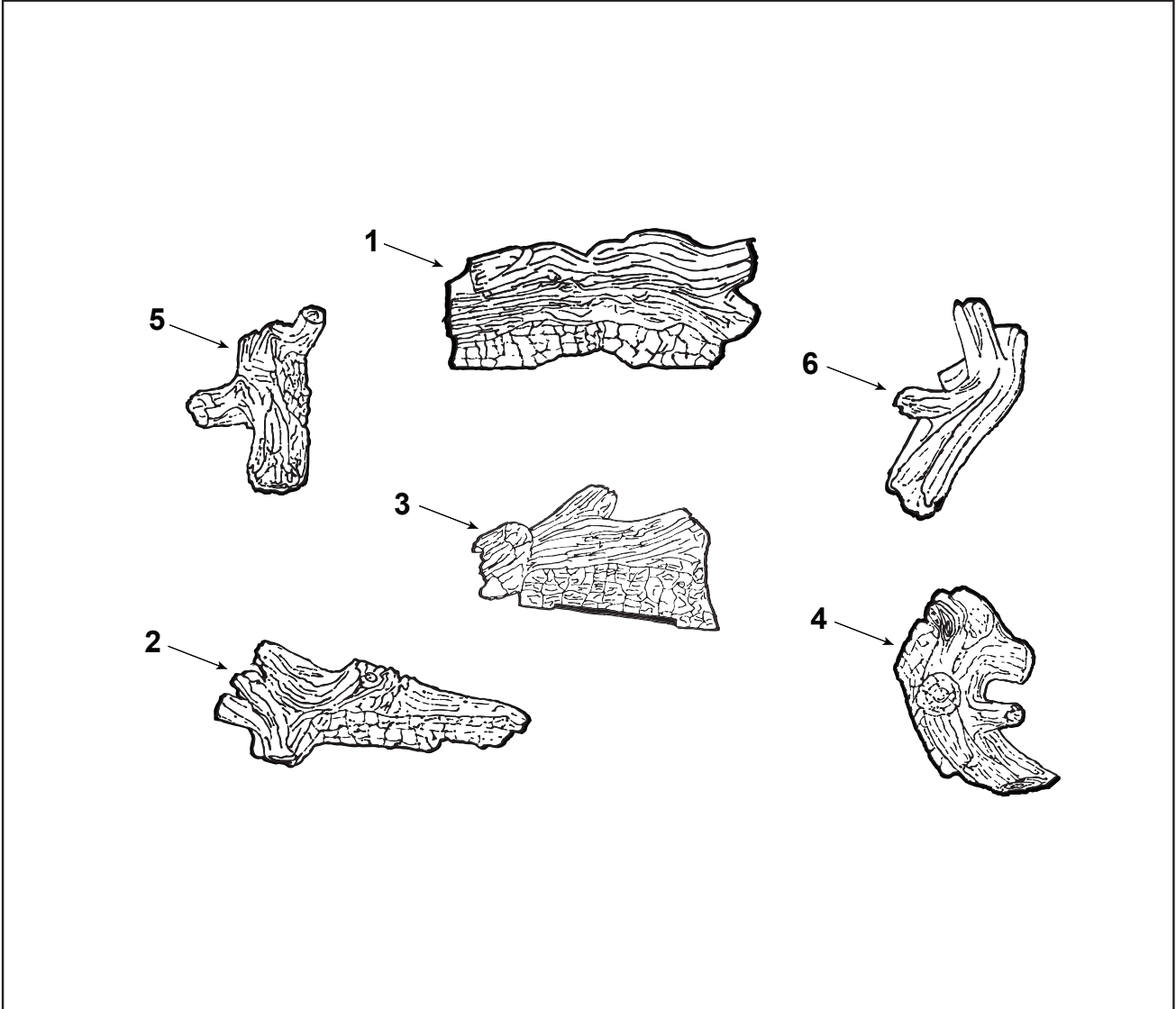

IMPORTANT: THIS IS DATED INFORMATION. Parts must be ordered from a dealer or distributor. **Hearth and Home Technologies does not sell directly to consumers.** Provide model number and serial number when requesting service parts from your dealer or distributor.



Stocked at Depot

ITEM	DESCRIPTION	COMMENTS	PART NUMBER
1	Rear Log		20308917
2	Front Left Log		20308750
3	Front Center Log		20308918
4	Right Log		20308921
5	Top Left Log		20308751
6	Center Top Log		20308753

B. Accessories

Hi Lo Kit Accessory

- The optional hi/lo kit adds remote flame height adjustment capability to your Natural Blaze Millivolt log set. It is not for use with IPI controlled sets. Note that it is not for use with the Beachcomber or Stony Creek log sets.

NOTE: The kit should be installed by a qualified installer.

Part Numbers:

HILOKTN - Hi/Lo Kit Natural

HILOKTP - Hi/Lo Kit Propane

MASSACHUSETTS RESIDENTS ONLY

Please read and follow these special requirements

NOTE REGARDING VENTED PRODUCTS

This product must be installed by a licensed plumber or gas fitter when installed within the Commonwealth of Massachusetts.

Any residence with a direct vent product must have a carbon monoxide (CO) detector installed in the residence.

Installation of the fireplace or vented gas log in the State of Massachusetts requires the damper to be permanently removed or welded in the fully open position.

In addition, a naturally vented gas log may not be installed in a bedroom or bathroom in the State of Massachusetts.

Flex line installation must not exceed 36 inches and must have a T shutoff valve.

NOTE REGARDING VENT FREE PRODUCTS

This product must be installed by a licensed plumber or gas fitter when installed within the Commonwealth of Massachusetts.

In addition, vent free products may not be installed in a bedroom or bathroom regardless of size or type in the State of Massachusetts.

Flex line installation must not exceed 36 inches and must have a T shutoff valve.

CARBON MONOXIDE DETECTOR REQUIREMENTS

(2) Revise 10.8.3 by adding the following additional requirements:

(a) For all side wall horizontally vented gas fueled equipment installed in every dwelling, building or structure used in whole or in part for residential purposes, including those owned or operated by the Commonwealth and where the side wall exhaust vent termination is less than seven (7) feet above finished grade in the area of the venting, including but not limited to decks and porches, the following requirements shall be satisfied:

1. **Installation of carbon monoxide detectors.** At the time of installation of the side wall horizontal vented gas fueled equipment, the installing plumber or gas fitter shall observe that a hard wired carbon monoxide detector with an alarm and battery back-up is installed on the floor level where the gas equipment is to be installed. In addition, the installing plumber or gas fitter shall observe that a battery operated or hard wired carbon monoxide detector with an alarm is installed on each additional level of the dwelling, building or structure served by the side wall horizontal vented gas fueled equipment. It shall be the responsibility of the property owner to secure the services of qualified licensed professionals for the installation of hard wired carbon monoxide detectors

a. In the event that the side wall horizontally vented gas fueled equipment is installed in a crawl space or an attic, the hard wired carbon monoxide detector with alarm and battery back-up may be installed on the next adjacent floor level.

b. In the event that the requirements of this subdivision can not be met at the time of completion of installation, the owner shall have a period of thirty (30) days to comply with the above requirements; provided, however, that during said thirty (30) day period, a battery operated carbon monoxide detector with an alarm shall be installed.

2. **Approved Carbon Monoxide Detectors.** Each carbon monoxide detector as required in accordance with the above provisions shall comply with NFPA 720 and be ANSI/UL 2034 listed and IAS certified.

3. **Signage.** A metal or plastic identification plate shall be permanently mounted to the exterior of the building at a minimum height of eight (8) feet above grade directly in line with the exhaust vent terminal for the horizontally vented gas fueled heating appliance or equipment. The sign shall read, in print size no less than one-half (1/2) inch in size, "GAS VENT DIRECTLY BELOW. KEEP CLEAR OF ALL OBSTRUCTIONS."

4. **Inspection.** The state or local gas inspector of the side wall horizontally vented gas fueled equipment shall not approve the installation unless, upon inspection, the inspector observes carbon monoxide detectors and signage installed in accordance with the provisions of 248 CMR 5.08(2)(a)1 through 4.

(b) **Exemptions:** The following equipment is exempt from 248 CMR 5.08(2)(a)1 through 4:

1. The equipment listed in Chapter 10 entitled "Equipment Not Required To Be Vented" in the most current edition of NFPA 54 as adopted by the Board; and

2. Product Approved side wall horizontally vented gas fueled equipment installed in a room or structure separate from the dwelling, building or structure used in whole or in part for residential purposes.

(c) **Manufacturer requirements — Gas Equipment Venting System Provided.** When the manufacturer of Product Approved side wall horizontally vented gas equipment provides a venting system design or venting system components with the equipment, the instructions provided by the manufacturer for installation of the equipment and the venting system shall include:

1. Detailed instructions for the installation of the venting system design or the venting system components; and

2. A complete parts list for the venting system design or venting system.

(d) **Manufacturer requirements — Gas Equipment Venting System Not Provided.** When the manufacturer of a Product Approved side wall horizontally vented gas fueled equipment does not provide the parts for venting the flue gases, but identifies "special venting systems," the following requirements shall be satisfied by the manufacturer:

1. The referenced "special venting system" instructions shall be included with the appliance or equipment installation instructions; and

2. The "special venting systems" shall be Product Approved by the Board, and the instructions for that system shall include a parts list and detailed installation instructions.

(e) A copy of all installation instructions for all Product Approved side wall horizontally vented gas fueled equipment, all venting instructions, all parts lists for venting instructions, and/or all venting design

