

This Owner's Manual is provided and hosted by [Appliance Factory Parts](#).



Monessen Hearth GLX24PT Owner's Manual

[Shop genuine replacement parts for Monessen Hearth
GLX24PT](#)



[Find Your Monessen Hearth Fireplace Parts - Select From 701 Models](#)

----- Manual continues below part list -----

Available Replacement Parts for Monessen Hearth GLX24PT

SRV00K0632	ASSY-WIRE
SRV14D0503	PIEZO IGNITER-snap in

UNVENTED GAS LOG HEATER OR VENTED DECORATIVE APPLIANCE INSTALLATION AND OPERATING INSTRUCTIONS

MODELS

DLX18/GLX18

DLX24/GLX24

DLX28/GLX28

Natural Gas or Propane/LPG

Control Type:

Manual, Thermostat or Milli-Volt

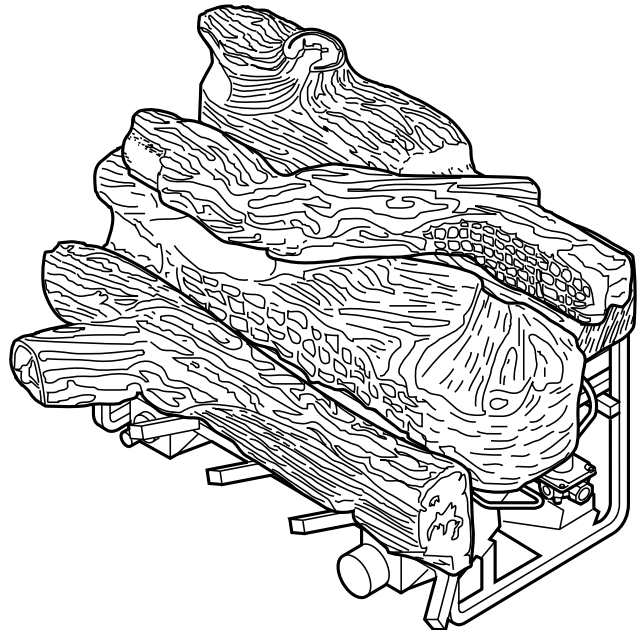

This is an unvented gas-fired heater. It uses air (oxygen) from the room in which it is installed. Provisions for adequate combustion and ventilation air must be provided. Refer to page 7.

WARNINGS

If the information in this manual is not followed exactly, a fire or explosion may result causing property damage, personal injury or loss of life.

- Do not store or use gasoline or other flammable vapors and liquids in the vicinity of this or any other appliance.
- WHAT TO DO IF YOU SMELL GAS
 - Do not try to light any appliance.
 - Do not touch any electrical switch; do not use any phone in your building.
 - Immediately call your gas supplier from a neighbor's phone. Follow the gas supplier's instructions.
 - If you cannot reach your gas supplier, call the fire department.
- Installation and service must be performed by a qualified installer, service agency or the gas supplier.

READ AND SAVE THESE INSTRUCTIONS

CONTENTS

CONTENTS	2
IMPORTANT SAFETY INFORMATION	3
GETTING STARTED	5
PRODUCT FEATURES AND SPECIFICATIONS	6
GENERAL INSTALLATION INFORMATION	7
FIREPLACE AND HEARTH DIMENSIONS	9
PLACEMENT IN A FIREPLACE WITH A RESTRICTIVE BARRIER	10
CLEARANCES AND HEIGHT REQUIREMENTS	11
FLOOR CLEARANCE	16
FIREPLACE PREPARATION	17
INSTALLING VENTED APPLICATIONS	18
CONNECTING THE GAS	19
CHECKING GAS PRESSURE	20
ELECTRICAL WIRING (MILLI-VOLT)	21
LOG PLACEMENT	23
FLAME APPEARANCE	24
CHECKING THE BURNER FLAME	25
OPERATING INSTRUCTIONS	26
FOR YOUR SAFETY READ BEFORE LIGHTING	26
MANUAL CONTROL LIGHTING INSTRUCTIONS	27
THERMOSTATIC CONTROL LIGHTING INSTRUCTIONS	28
MILLI-VOLT CONTROL LIGHTING INSTRUCTIONS	29
MATCH LIGHTING INSTRUCTIONS	30
CLEANING AND SERVICING	31
REPLACEMENT PARTS LIST	32
TROUBLESHOOTING	36

IMPORTANT SAFETY INFORMATION

INSTALLER

Please leave these instructions with the owner.

OWNER

Please retain these instructions for future reference.

IMPORTANT

Read these instructions carefully before installing or trying to operate this vent-free gas heater.

WARNING

- Any change to this heater or its controls can be dangerous.
- Improper installation or use of the heater can cause serious injury or death from fire, burns, explosion or carbon monoxide poisoning.
- Do not allow fans to blow directly into the fireplace. Avoid drafts that alter burner flame patterns.
- Do not use a blower insert, heat exchanger insert or other accessory, not approved for use with this heater where applicable.

1. Due to high temperatures, the heater should be located out of traffic and away from furniture and draperies.
 2. Children and adults should be alerted to the hazard of high surface temperature and should stay away to avoid burns or clothing ignition.
 3. Young children should be carefully supervised when they are in the same room with the heater
 4. Do not place clothing or other flammable material near the fireplace when the heater is in use.
 5. Any safety screen or guard removed for servicing, must be replaced prior to operating the heater.
 6. Installation and repair should be done by a qualified service person.
 7. To prevent malfunction and/or sooting, an unvented gas heater should be cleaned at least annually by a professional service person. More frequent cleaning may be required due to excessive lint from carpeting, etc. It is imperative that control compartments, burners and circulating air passageways be kept clean.
8. **CARBON MONOXIDE POISONING:** Early signs of carbon monoxide poisoning are similar to the flu with headaches, dizziness and/or nausea. If you have these signs, obtain fresh air immediately. Have the heater serviced as it may not be operating properly.
 9. The installation must conform with local codes or, in the absence of local codes, with the National Fuel Gas Code, ANSI Z223.1.

10. This unit complies with ANSI Z21.11.2b-1998 Unvented Heaters and also complies with ANSI Z21.60-1996 Decorative Vented Appliances for Solid Fuel Burning Fireplaces. State and local codes may only allow operation of this appliance in a vented configuration. Check your state or local codes. For vented operation, see “VENTED INSTRUCTIONS” in this manual.
11. Do not install the heaters in a bathroom or bedroom.
12. Correct installation of the ceramic fiber logs, proper location of the heater, and annual cleaning are necessary to avoid potential problems with sooting. Sooting, resulting from improper installation or operation, can settle on surfaces outside the fireplace. See log placement instructions for proper installation.
13. Avoid any drafts that alter burner flame patterns. Do not allow fans to blow directly into fireplace. Do not place a blower inside burn area of firebox. Ceiling fans may create drafts that alter burner flame patterns. Sooting and improper burning will occur.
14. **Caution:** Candles, incense, oil lamps, etc. produce combustion byproducts including soot. Vent-free appliances will not filter or clean soot produced by these types of products. In addition, the smoke and/or aromatics (scents) may be reburnt in the vent-free appliance which can produce odors. It is recommended to minimize the use of candles, incense, etc. while the vent-free appliance is in operation.
15. This is an unvented gas-fired heater. It uses air (oxygen) from the room in which it is installed. Provisions for adequate combustion and ventilation air must be provided. Refer to installation guidelines.

Continued on page 4

IMPORTANT SAFETY INFORMATION

Continued from page 3

16. Keep room area clear and free from combustible materials, gasoline and other flammable vapors and liquids.
17. Unvented gas heaters are a supplemental zone heater. They are not intended to be a primary heating appliance. Water vapor produced by an unvented heater can create moisture problems in a home when operated for extended periods of time.
18. During manufacturing, fabricating and shipping, various components of this appliance are treated with certain oils, films or bonding agents. These chemicals are not harmful but may produce annoying smoke and smells as they are burned off during the initial operation of the appliance; possibly causing headaches or eye or lung irritation. This is a normal and temporary occurrence.

The initial break-in operation should last two to three hours with the burner at the highest setting. Provide maximum ventilation by opening windows or doors to allow odors to dissipate. Any odors remaining after this initial break-in period will be slight and will disappear with continued use.
19. Input ratings are shown in BTU per hour and are for elevations up to 2,000 feet. For elevations above 2,000 feet, input ratings should be reduced 4 percent for each 1,000 feet above sea level. Refer to the National Fuel Gas Code.
20. The heater and its individual shutoff valve must be disconnected from the gas supply piping system during any pressure testing of that system at test pressures in excess of 1/2 psig (3.5 kPa).
21. The heater must be isolated from the gas supply piping system by closing its individual manual shutoff valve during any pressure testing of the gas supply piping system at test pressures equal to or less than 1/2 psig (3.5 kPa).
22. Do not use this room heater if any part has been under water. Immediately call a qualified service technician to inspect the room heater and to replace any part of the control system and any gas control which has been under water.
23. This appliance must not be used with glass doors in the closed position. This can lead to pilot outages and severe sooting outside the fireplace.

24. Never burn solid fuels in a fireplace where a unvented room heater is installed.
25. Always have a fireplace screen in place when the appliance is in operation and , unless other provisions for combustion air are provided, the screen shall have an opening(s) for induction of combustion air.

This appliance may be installed in an aftermarket, permanently located, manufactured (mobile) home, where not prohibited by local codes.

This appliance is only for use with the type of gas indicated on the rating plate. This appliance is not convertible for use with other gases.

MAKE SURE YOU HAVE RECEIVED ALL PARTS:

Check your packing list to verify that all listed parts have been received. You should have the following:

- Unvented gas log grate/burner assembly.
- Installation/operating instructions.
- Ceramic fiber logs.
- Two (2) anchoring screws.
- Plastic bag containing crushed volcanic rock.

The millivolt controlled version of this heater is the only style designed to be operated with optional devices for ON/OFF functions. The following options may be used with the millivolt controlled heater. These options are not packaged with the log set.

- Hand held Remote w/receiver.
- Wall Switch with 20' wire.
- Wall T-stat with 20' wire.
- Hand held Thermostat Remote w/receiver.

CAUTION

Handle the gas log burner assembly by the grate only. Do not pick the unit up by the burners.

Gloves are recommended when handling ceramic fiber logs to prevent skin irritation from loose fibers. Logs are fragile – handle with care.

Carefully inspect the contents for shipping damage. If any parts are missing or damaged, immediately inform the dealer from whom you purchased the appliance. **Do not attempt to install any part of the appliance unless you have all parts in good condition.**

What you will need for installation:

You must have the following items available before proceeding with installation:

- External regulator (for propane/L.P.G. only)
- Piping which complies with local codes
- Pipe sealant approved for use with propane/L.P.G. (Resistant to sulfur compounds)
- Manual shutoff valve
- Sediment trap
- Tee joint
- Pipe wrench or appropriate size crescent wrench set
- Screwdriver
- Drill, with 5/32 bit

PRODUCT FEATURES AND SPECIFICATIONS

NATURAL GAS

MANUAL / T-STAT PRESSURE

Regulator Pressure Setting: 3" w.c.

Gas Inlet Pressure: Maximum 10 1/2" w. c.
Minimum 5" w.c.

MILLIVOLT PRESSURE

Regulator Pressure Setting: 3.5" w.c.

Pilot Regulator: 3.5" w.c.

Gas Inlet Pressure: Max. 10 1/2" w. c.
Min. 5" w.c.

Model Number	Control	Gas Rate	
		Max BTU/Hr	Min BTU/Hr
DLX18NV, GLX18NV	Manual	26,000	16,000
DLX24/28NM, GLX24/28NM	Manual	32,000	19,000
DLX18NT, GLX18NT	T-Stat	26,000	16,000
DLX24/28NT	Milli-Volt	26,000	20,000
DLX18NV, GLX18NV	Milli-Volt	26,000	17,000
DLX24/28NV, GLX24/28NV	Milli-Volt	32,000	22,000

PROPANE / LPG

Note: An external regulator is required to reduce supply pressure to a maximum of 13" w. c.

MANUAL / T-STAT PRESSURE

Regulator Pressure Setting: 10" w.c.

Gas Inlet Pressure: Maximum 13" w.c.
Minimum 11" w.c.

MILLIVOLT PRESSURE

Regulator Pressure Setting: 10" w.c.

Gas Inlet Pressure: Maximum 13" w.c.
Minimum 11" w.c.

Model Number	Control	Gas Rate	
		Max BTU/Hr	Min BTU/Hr
DLX18PV, GLX18PV	Manual	22,000	14,000
DLX24/28PM, GLX24/28PM	Manual	33,000	19,000
DLX18PT, GLX18PT	T-Stat	26,000	16,000
DLX24/28PT	Milli-Volt	28,000	20,000
DLX18PV, GLX18PV	Milli-Volt	22,000	17,000
DLX24/28PV, GLX24/28PV	Milli-Volt	33,000	22,000

IGNITION CONTROLS

Piezo ignitor allows ignition of the pilot without the use of matches or batteries.

Manual control has four (4) positions:

OFF - All gas to the gas logs is shut off at the valve.

IGN - Valve position to light/maintain a standing pilot.

LOW - Minimum gas rate — front burner provides a realistic glow on the center log.

HI - Maximum gas rate — front burner provides a realistic glow on the center log, plus the rear burner provides a pleasing yellow flame.

GENERAL INSTALLATION INFORMATION

Thermostat control has three (3) positions:

- OFF** - All gas to the gas logs is shut off at the valve.
- IGN** - Valve position to light/maintain a standing pilot.
- LOW/HI** - Variable position corresponding to desired temperature. Both front and rear burners are in operation to provide realistic glow and yellow flame.

Milli-Volt control has four (4) positions:

- OFF** - All gas to the gas logs is shut off at the valve.
- IGN** - Valve position to light/maintain a standing pilot.
- ON** - Valve position to turn ON/OFF log set with remote switch/thermostat or with ON/OFF switch on the set.
- LOW/HI** - Variable position to control flame height (heat output). Both front and rear burners are in operation to provide realistic glow and yellow flame.

CODES

Adhere to all local codes or, in their absence, the latest edition of THE NATIONAL FUEL GAS CODE ANSI Z223.1 or NFPA54 which can be obtained from...

American National Standards Institute, Inc.

1430 Broadway
New York, NY 10018

or

National Fire Protection Association, Inc.

Batterymarch Park
Quincy, MA 02269

ADEQUATE COMBUSTION AND VENTILATION AIR

This heater shall not be installed in a confined space or unusually tight construction unless provisions are provided for adequate combustion and ventilation air.

The National Fuel Gas Code, (ANSI Z223.1), defines a confined space as a space whose volume is less than 50 cubic feet per 1,000 BTU per hour (4.8 m³ per kw) of the aggregate input rating of all appliances installed in that space. An unconfined space is defined as a space whose volume is not less than 50 cubic feet per 1,000 BTU per hour (4.8 m³ per kw) of the aggregate input rating of all appliances installed in that space. Rooms communicating directly with the space in which the appliances are installed, through openings not furnished with doors, are considered a part of the unconfined space.

UNUSUALLY TIGHT CONSTRUCTION IS DEFINED AS CONSTRUCTION WHERE...

- a) walls and ceilings exposed to the outside atmosphere have a continuous water vapor retarder with a rating of 1 perm (6 x 10¹¹ kg per-pa-sec-m²) or less with openings gasketed or sealed, and
- b) weather striping has been added on openable windows and doors, and
- c) caulking or sealant are applied to areas such as joints around windows and door frames; between sole plates and doors; between wall-ceiling joints; between wall panels; at penetrations for plumbing, electrical, and gas lines; and at other openings.

GENERAL INSTALLATION INFORMATION

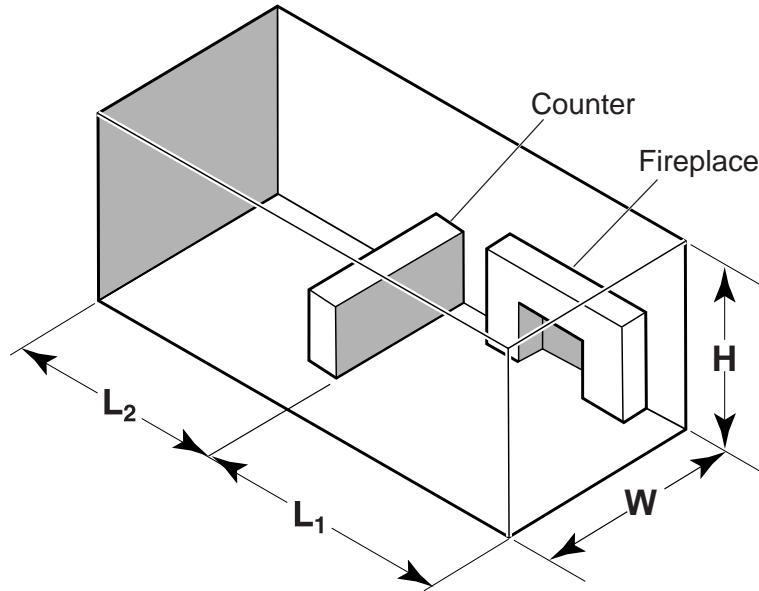

Figure 1 - Example of a Large Room with 1/2 Wall Divider

The following formula can be used to determine the maximum heater rating per the definition of unconfined space:

$$\frac{\text{BTU/HR} = (L_1 + L_2) \text{ Ft} \times (W) \text{ Ft} \times (H) \text{ Ft} \times 1000}{50}$$

Consider two connecting rooms with an open area between, with the following dimensions:

$L_1 = 15\frac{1}{2}$ Ft., $L_2 = 12$ Ft., $W = 12$ Ft., $H = 8$ Ft.

$$\frac{\text{BTU/HR} = (15\frac{1}{2} + 12) \times (12) \times (8) \times 1000}{50} \times 1000 = 52800 \text{ BTU/HR}$$

If there were a door between the two rooms the calculation would be based only on the room with the heater.

$$\frac{\text{BTU/HR} = (15\frac{1}{2}) \times (12) \times (8) \times 1000}{50} \times 1000 = 29760 \text{ BTU/HR}$$

WARNING

If the area in which the heater may be operated is smaller than that defined as an unconfined space or if the building is of unusually tight construction, provide adequate combustion and ventilation air by one of the methods described in the National Fuel Gas Code, ANSI Z223.1, Section 5.3 or applicable local codes.

WARNING

This appliance is for installation only in a solid-fuel burning masonry or UL127 factory-built fireplace or in a listed ventless firebox enclosure. It has been design certified for these installations. Exception: DO NOT install this appliance in a factory-built fireplace that includes instructions stating that it has not been tested or should not be used with unvented gas logs.

Use manufacturer's installation and clearance requirements as defined in their manual.

The LX Series unvented room heater may also be installed into a Ventless Firebox Enclosure for Gas Fired Decorative Type Unvented Room Heaters per IAS Requirement No. 2-97 (typically referred to as a "Universal Firebox"), as long as firebox hearth dimensions meet the minimum hearth dimensions shown below.

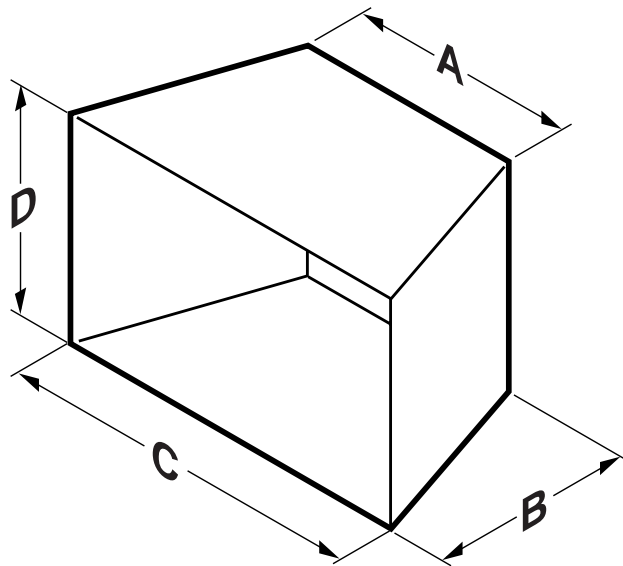

Model	A	B	C	D
DLX18/GLX18	17 ¹ / ₂ "	13 ¹ / ₄ "	27"	17"
DLX24/GLX24	17 ¹ / ₂ "	14"	29"	17"
DLX28/GLX28	21"	14"	33"	17"

Figure 2 - Hearth Minimum Dimension for Ventless Universal Fireboxes, Solid Fuel Burning Fireplaces and UL127 Factory Built Fireplaces

PLACEMENT IN A FIREPLACE WITH A RESTRICTIVE BARRIER

IMPORTANT INFORMATION FOR THE INSTALLATION OF THIS GAS LOG SET

The following are guidelines for placing a gas log set in a fireplace that has a restrictive barrier along the bottom front opening of the fireplace. Some examples of barriers are glass/screen door frames and sunken/recessed fireplaces.

Height of Restriction (X)	Minimum Depth of Fireplace/Firebox
No restriction	13 ¹ / ₄ "
0 to 1.5"	16"
Greater than 1 ¹ / ₂ " to 3"	16"
Greater than 3:	ANY BARRIER GREATER THAN THREE INCHES (3") PLACED IN FRONT OF THE GAS LOG SET IS NOT RECOMMENDED BY THE MANUFACTURER.

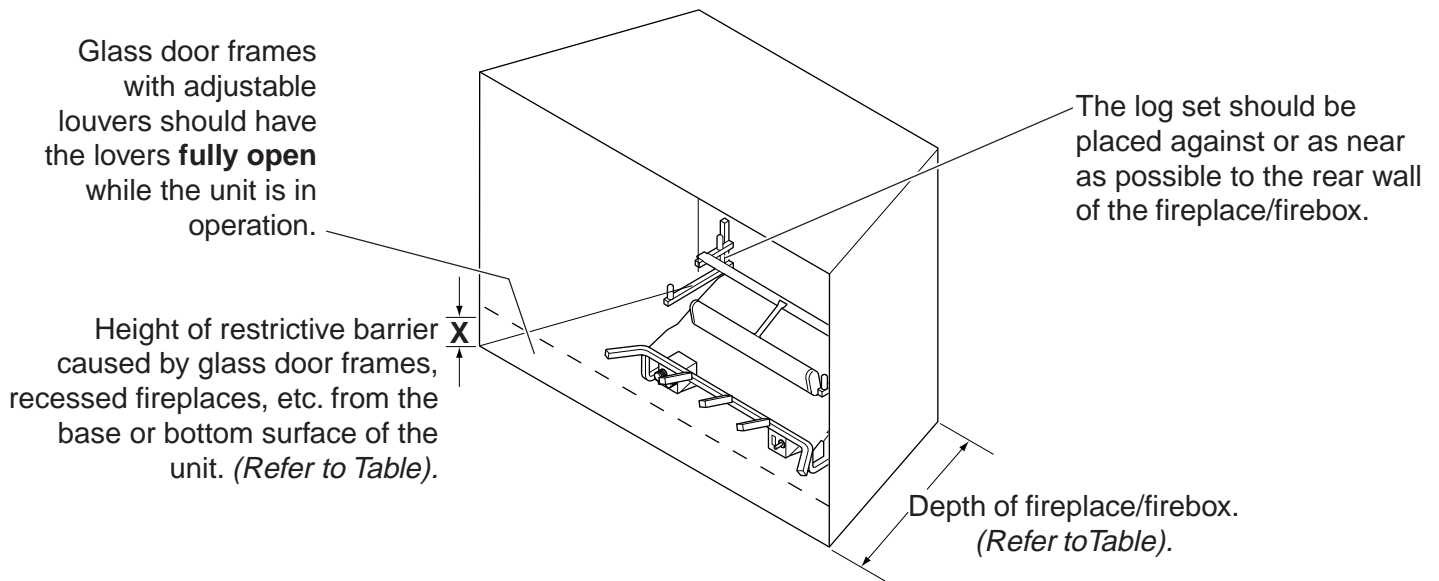

Figure 3 - Reference Drawing of a Natural Flame Log Set in an Enclosure

WARNING

Barriers such as the bottom of a glass door frame placed in front of a gas log set can change the air flow characteristics of the fireplace which in turn can cause the unit to overheat and malfunction.

NOTE: Non combustible material such as refractory brick may be used to line the floor of the fireplace in order to raise the height of the gas log set in relation to a restrictive barrier. If the unit is raised, the minimum height dimension listed in the homeowner's manual must not be exceeded.

NOTE: If the log set is equipped with a remote receiver, a restrictive barrier may reduce the battery life by increasing the ambient temperature inside the fireplace. Placement of the receiver outside of the fireplace will extend the battery life.

CLEARANCES AND HEIGHT REQUIREMENTS

WARNING

The dimensions shown in Figures 3 through 11 and defined in the fireplace manufacturer's instructions are minimum clearances to maintain when installing this heater. Left and right clearances are determined when facing the front of the heater.

When heater is installed into a ventless firebox, minimum clearances, as specified by the ventless firebox manufacturer, must be met.

Follow these instructions carefully to ensure safe installation. Failure to follow instructions exactly can create a fire hazard.

Sidewall and ceiling clearances: The *sides* of the fireplace opening must be *at least 16"* from any combustible wall. The *ceiling* must be *at least 42"* from the top of the fireplace opening.



Figure 4 - Sidewall & Ceiling Clearances

CLEARANCES and HEIGHT REQUIREMENTS

Heat resistant material (minimum requirements) with no wooden mantel or other combustible projection:

To install the gas logs into a fireplace with no wooden mantel, shelf or other combustible projection above the fireplace opening, measure the heat resistant material height, *per Figure 4*, then refer to **TABLE A**.

Heat resistant materials such as slate and marble must be at least 1/2" thick. Sheet metal should not be installed onto combustible material.

IMPORTANT: If you cannot meet these minimum clearances you must operate the heater with chimney flue damper open. Refer to "INSTALLING VENTED APPLICATIONS" found on page 17.

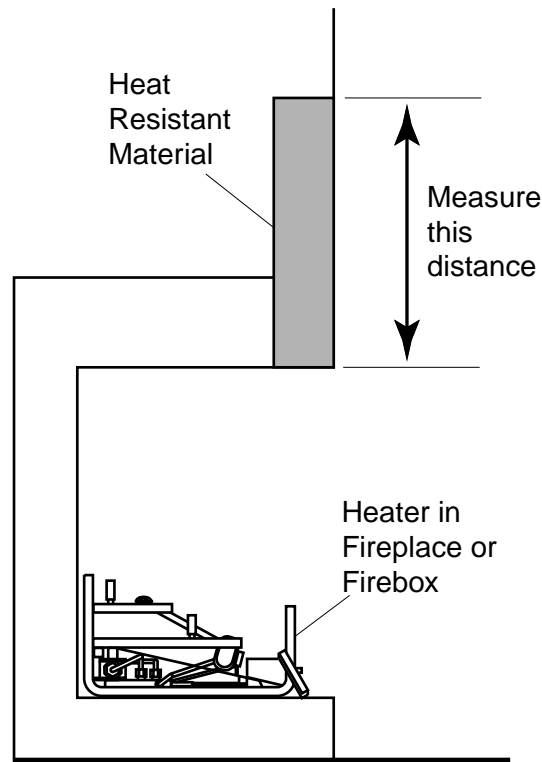

Figure 5 - Measuring Heat Resistant Material

HEAT RESISTANT MATERIAL MEASUREMENT	REQUIREMENTS FOR SAFE INSTALLATION	
	DLX18/GLX18 All Models	DLX/GLX 24 AND 28 All Models
12" or more	Hood not required.	Hood not required.
8" to less than 12"	Hood not required.	Extend heat resistant material to 12" or install hood. <i>See Figure 5.</i>
Less than 8"	Extend heat resistant material to at least 8"	Extend heat resistant material to at least 8" and install hood. <i>See Figure 5.</i> OR , extend heat resistant material to a height of at least 12".

TABLE A - Heat Resistant Material Requirements with no Mantel or Combustible Projection

CLEARANCES AND HEIGHT REQUIREMENTS

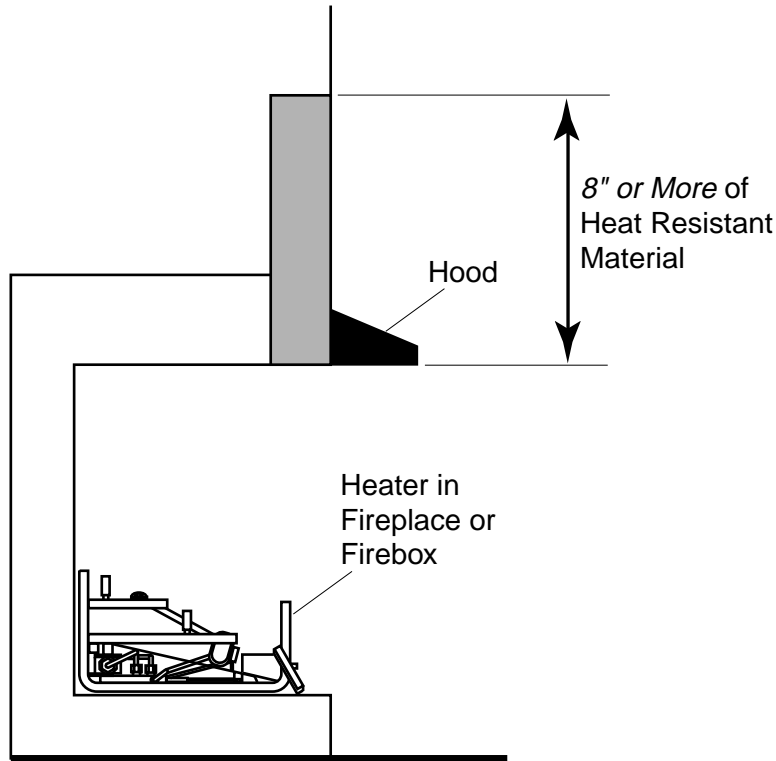

Figure 6 - Measuring Heat Resistant Material for Mantel

Heat resistant material (minimum requirements) with wooden mantel or other combustible projection:

To install the heater with a wooden mantel, shelf or other combustible projection above, first measure the heat resistant material shown in *Figure 6*.

HEAT RESISTANT MATERIAL MEASUREMENT	REQUIREMENTS FOR SAFE INSTALLATION WITH WOODEN MANTEL, SHELF OR OTHER COMBUSTIBLE PROJECTION	
	DLX/GLX 18	DLX/GLX 24 AND 28
12" or more	Hood not required. Observe profiles (side elevations) shown in <i>Figure 7, page 14</i> .	Hood not required. Observe profile (side elevations) shown in <i>Figure 9, page 15</i> .
8" to less than 12"	Install hood and observe profiles shown in <i>Figure 8, page 14</i> ; OR extend heat resistant material to at least 12" and observe profiles shown in <i>Figure 7, page 14</i> .	Install hood and observe profiles shown in <i>Figure 7, page 14</i> ; OR extend heat resistant material to at least 12" and observe profiles shown in <i>Figure 9, page 15</i> .
Less than 8"	Extend heat resistant material to at least 8", install hood and observe profiles shown in <i>Figure 8, page 14</i> ; OR extend heat resistant material to at least 12" and observe profiles shown in <i>Figure 8, page 14</i> .	Extend heat resistant material to at least 8", install hood and observe profiles shown in <i>Figure 7, page 14</i> ; OR extend heat resistant material to at least 12" and observe profiles shown in <i>Figure 8, page 14</i> .

TABLE B - Heat Resistant Material Heights and Mantel Location

CLEARANCES AND HEIGHT REQUIREMENTS

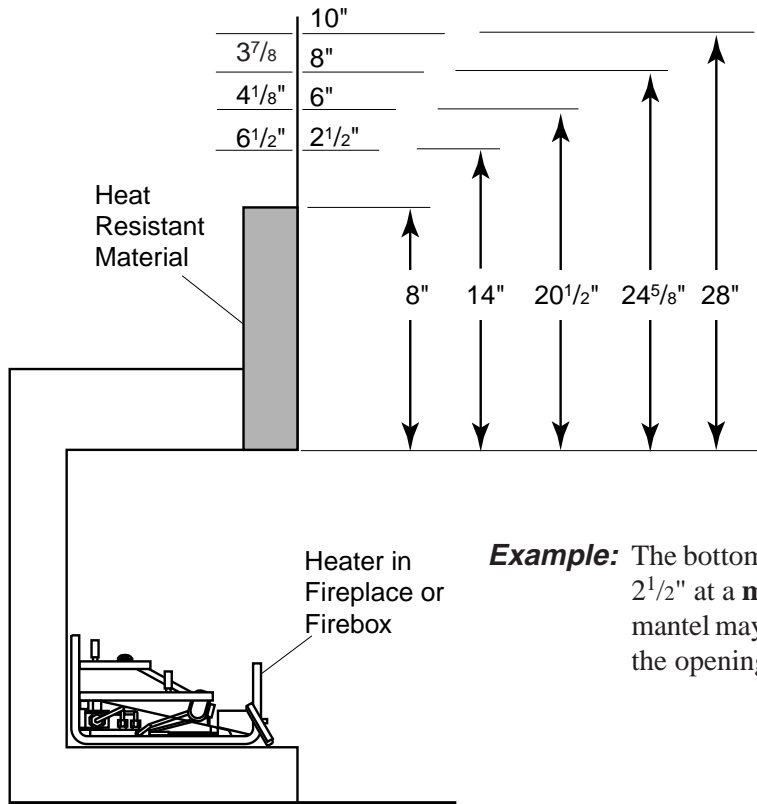

Figure 7 - Minimum Mantel Clearance with No Hood — DLX/GLX 18

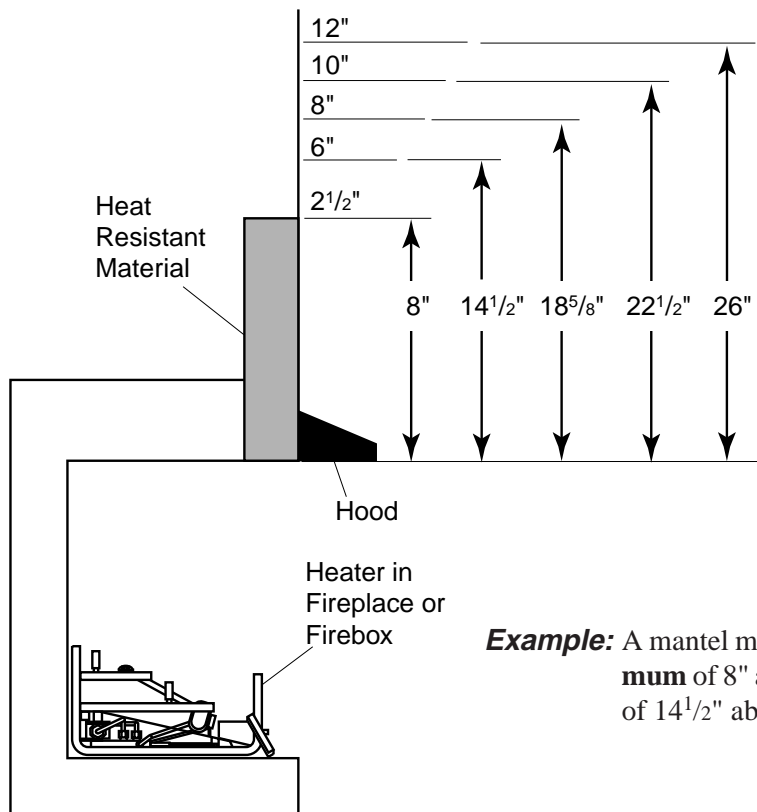
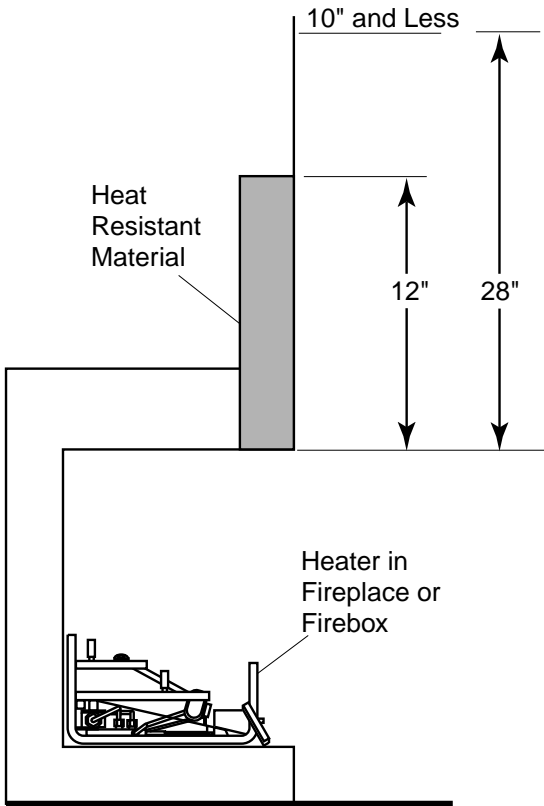

Figure 8 - Minimum Mantel Clearance with Hood — All Models



Example: The bottom of the mantel may project from the wall a maximum of 10" at a minimum of 28" above the opening.

Figure 9 - Minimum Mantel Clearance with No Hood — DLX/GLX 24 and 28

Figure 10 is an example of an unsafe mantel installation. This mantel projects 4" at 8" above the opening, exceeding the maximum acceptable distance of 2½". The mantel also projects 7" at 14½" above the opening, exceeding the maximum acceptable distance of 6".

If your mantel profile is unsafe, you may either:

- Raise the mantel to an acceptable height

OR

- Remove the mantel



Figure 10 - Unacceptable Mantel Clearance

FLOOR CLEARANCE

The gas log heater must be installed at least 5" above any combustible flooring material, such as carpeting or tile, which is closer than 14" to the base of the fireplace. *Refer to Figure 11.*

OR,

The gas log heater may be installed nearer to the floor if a minimum of 14" of noncombustible material such as slate or marble is installed between the base of the fireplace and the combustible flooring. *Refer to Figure 12.*

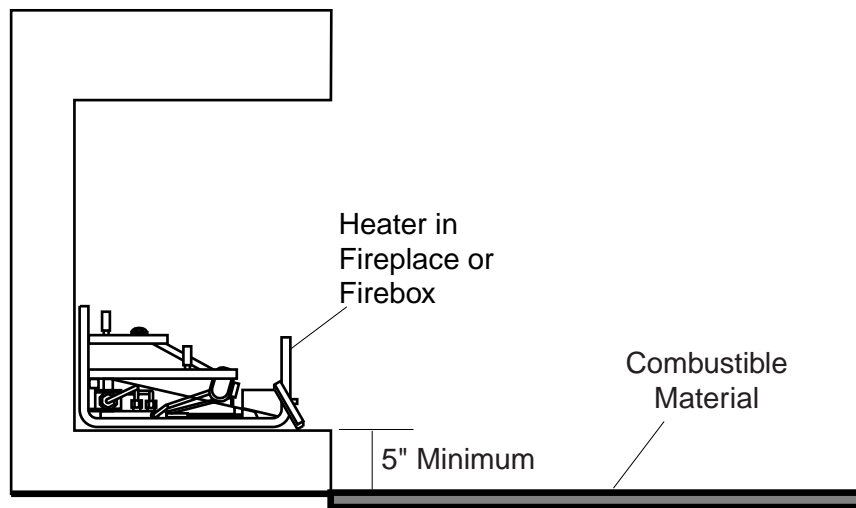

Figure 11 - Minimum Clearance above Combustible Flooring



Figure 12 - Minimum Clearance above Combustible Flooring with Noncombustible Material Installed at Base of Fireplace

BEFORE FULLY INSTALLING THE UNIT:

- Turn **OFF** the gas supply to the fireplace or firebox.
- Seal any fresh air vents and/or ash clean-out doors located on the floor or wall of the fireplace. If left unsealed, drafting may cause pilot outage or sooting. Use a heat resistant sealant. **Do not seal the chimney flue damper.**

WARNING

Before installing in a solid fuel burning fireplace, The chimney flue and firebox must be cleaned of soot, creosote, ashes and loose paint by a qualified chimney cleaner.

INSTALLING VENTED APPLICATIONS

Manual and millivolt controlled gas logs may be installed as a vented decorative log set in compliance with ANSI Z21.60 and National Fuel Gas Code, Section 6.6 Since, the gas logs are operated with the damper open, non-combustible material and minimum mantel requirements do not apply.

WARNING

This appliance is for installation only in a solid fuel burning fireplace (masonry fireplace or manufactured fireplace) with a working flue and constructed of noncombustible material. Exception: **DO NOT** install this appliance in a factory-built fireplace that includes instructions stating it has not been tested or should not be used with unvented gas logs.

BEFORE INSTALLING THE APPLIANCE:

- Turn off gas supply to fireplace or firebox.
- Have the fireplace floor and chimney professionally cleaned to remove ashes, soot, creosote or other obstructions. Have this cleaning performed annually after installation.
- Seal any fresh air vents or ash clean-out doors located on floor or wall of fireplace. If not, drafting may cause pilot outage or sooting. Use a heat-resistant sealant. Do not seal chimney flue damper.

Install and operate the appliance as directed in this manual.

DAMPER STOP INSTALLATION:

A damper stop must be provided with the unit. Contact your dealer to obtain one. The damper stop must be installed as shown in *Figure 13* to prevent full closure of the fireplace damper blade and provide a minimum 29 square inch flue opening.



Figure 13 - Damper Stop Installation.
(See **WARNING** at top of next page.)

INSTALLING VENTED APPLICATIONS

WARNING

The fireplace and gas logs function as a system. If the fireplace is spilling into the room (check with a match or a smoke stick), reposition the damper clamp until a positive draft is obtained by opening the damper. If negative pressure in home prevents having a positive draft, contact your dealer for assistance.

PLACING AND SECURING APPLIANCE

WARNING

You must secure the gas log heater to the fireplace floor. If not, the entire unit may move when you adjust the controls. Movement of unit may cause shifting of the gas logs which leads to sooting and improper burning. Grate movement could cause a gas leak.

Special care is required if you are installing the unit into a sunken fireplace. You must raise the fireplace floor to allow access to gas log controls. This will insure adequate air flow and guard against sooting. Raise the fireplace floor using noncombustible materials, as described in "PLACEMENT IN A FIREPLACE WITH A RESTRICTIVE BARRIER" on page 10.

ASSEMBLY PROCEDURE:

1. Center the gas log unit in the fireplace or firebox. Make certain the front feet of the grate sit inside the front edge of the fireplace or firebox.
2. Refer to Figure 14 for hole locations. After centering the grate correctly, mark the hole positions on the fireplace/firebox floor. Drill two (2) $\frac{5}{32}$ " diameter holes approximately $1\frac{1}{2}$ " deep.
3. Anchor the grate to the fireplace/firebox floor using the screws provided. *Refer to Figure 14.*

Proper installation of the grate is essential to prevent any movement of the gas logs and controls during operation.



Figure 14 - Securing Heater to Floor of Fireplace/Firebox

NOTICE: A qualified gas appliance installer must connect the heater to the gas supply. Consult all local codes.

CAUTION

Use new black iron or steel pipe. Internally tinned copper or copper tubing can be used per National Fuel Code, section 2.6.3, providing gas meets hydrogen sulfide limits, and where permitted by local codes. Gas piping system must be sized to provide minimum inlet pressure (Listed on Data Plate) at the maximum flow rate (BTU/Hr). Undue pressure loss will occur if the pipe is too small.

A manual shutoff valve must be installed upstream of the appliance. Union tee and plugged $\frac{1}{8}$ " NPT pressure tapping point should be installed upstream of the appliance. Refer to Figure 15.

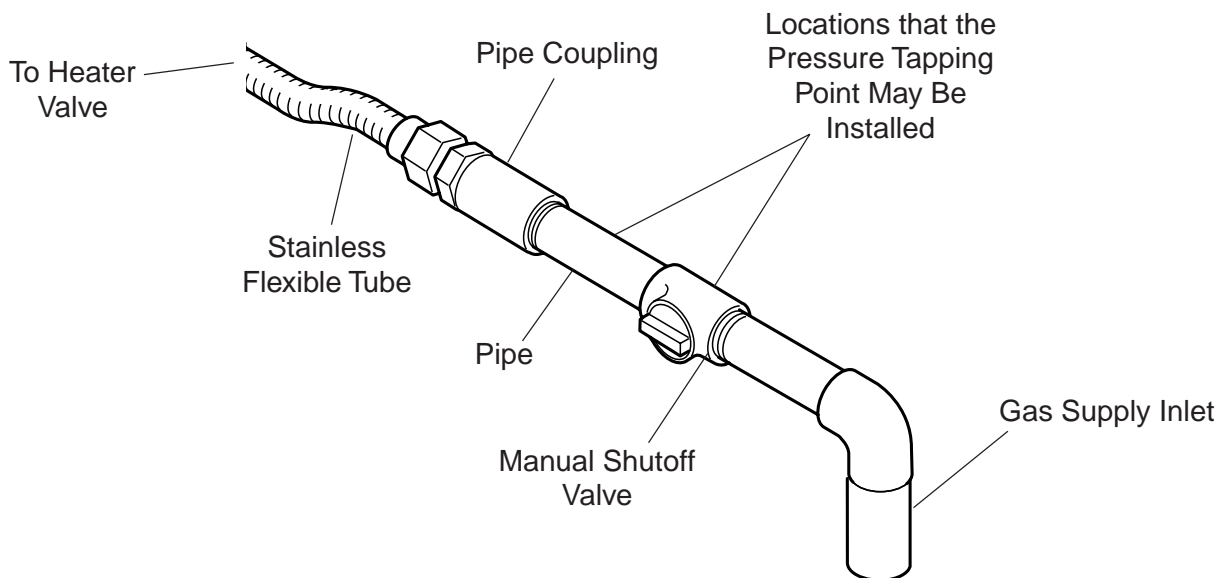

Figure 15 - Gas Connection

IMPORTANT: Hold heater valve firmly with a wrench to prevent movement when connecting to inlet pipe.

CAUTION

CHECK GAS TYPE: The gas supply must be the same as stated on the heater's rating plate. If the gas supply is different, **DO NOT INSTALL THE HEATER.** Contact your dealer for the correct model.

Always use an external regulator for all propane/LPG heaters only, to reduce the supply tank pressure to a maximum of 13" w.c. This is in addition to the internal regulator in the heater valve.

CHECKING GAS PRESSURE

WARNING

Connecting directly to an unregulated propane/LPG tank can cause an explosion.

The heater gas inlet connection is a $\frac{3}{8}$ " NPT at the valve. On all control type units, the inlet connection is on the right side of the unit. To connect from the opposite side, route the pipe under the rear portion of the unit.

When tightening up the joint to the valve, hold the valve securely to prevent movement.

Test all gas joints from the gas meter to the heater valve for leaks using a gas analyzer or soap and water solution after completing connection. **DO NOT USE AN OPEN FLAME.**

Check the gas pressure with the appliance burning and the control set to **HIGH**.

MANUAL CONTROL (Figure 16)

The pressure regulator is preset and locked to discourage tampering. If the pressure is not as specified, replace the regulator with the correct part from the parts list in this manual.

Remove $\frac{1}{8}$ " NPT plug, located on either side of regulator body. Install fitting and tubing to pressure gauge. After taking pressure reading, reinstall test plug. Check for gas leaks.



Figure 16 - Pressure Test Point Location

THERMOSTAT CONTROL (Figure 17)

Turn captured screw counter clockwise two or three turns and then place tubing to pressure gauge over test point (Use test point closest to control knob). After taking pressure reading, be sure and turn captured screw clockwise firmly to reseal. Do not over torque. Check for gas leaks.

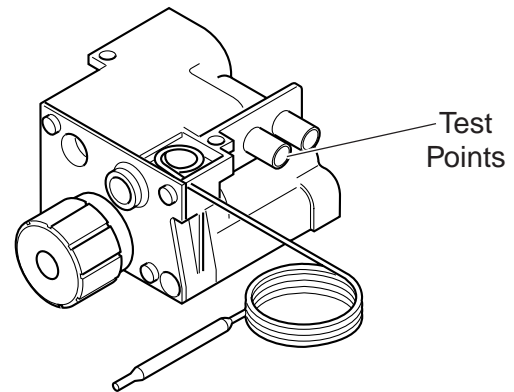

Figure 17 - Alternate Test Point Location for Thermostat Control Unit

MILLIVOLT CONTROL (Figure 18)

The valve regulator controls the burner pressure which should be checked at the pressure test point.

Turn captured screw counter clockwise two or three turns and then place tubing to pressure gauge over test point. (Use test point "OUT" closest to gas inlet). After taking pressure reading, be sure and turn captured screw clockwise firmly to reseal. Do not over torque. Check for gas leaks.



Figure 18 - Pressure Test Point Location

The milli-volt valve is a self-powered combination gas control **THAT DOES NOT USE 110 VAC TO OPERATE.**

CAUTION

Label all wires prior to disconnection when servicing controls. Wiring errors can cause improper and dangerous operation. Verify proper operation after servicing.



Figure 19 - Wiring Diagram

CONNECTING OPTIONAL WALL SWITCH OR THERMOSTAT

1. Use 18 awg, two-wire cable, 20 feet maximum length.
2. At one end of the cable, connect both wires to the wall switch or thermostat. At the other end, connect one wire to TP/TH and one wire to TH. The color of the wires does not matter.

ELECTRICAL WIRING (MILLI-VOLT)

CONNECTING REMOTE RECEIVER

THESE INSTRUCTIONS SUPERCEDE THE SECTION ENTITLED "HEARTH MOUNT" IN THE MILLI-VOLT HAND-HELD REMOTE INSTRUCTIONS SUPPLIED WITH THE REMOTE.

1. Cut cable to length (approximately 12") for placement in the fireplace.
2. Strip back 1/4" of the insulation from both ends of each wire.
3. Connect two .25 female connectors to the wires at one end of the cable.
4. Insert the opposite ends of the wires into the receiver wire terminals and tighten the screws.
5. Connect the connectors to the two .25" male connectors located on the left side when facing the unit (See Figure 19, page 21). Do not let wire touch grate or burner.
6. Remove the hearthmount coverplate on the remote receiver. (Battery pack must be temporarily removed prior to removing the cover plate). Stick velcro pads with self-adhesive backing to top of remote receiver and to the underside of the unit. Refer to Figure 20.
7. Attach remote receiver with velcro pads.

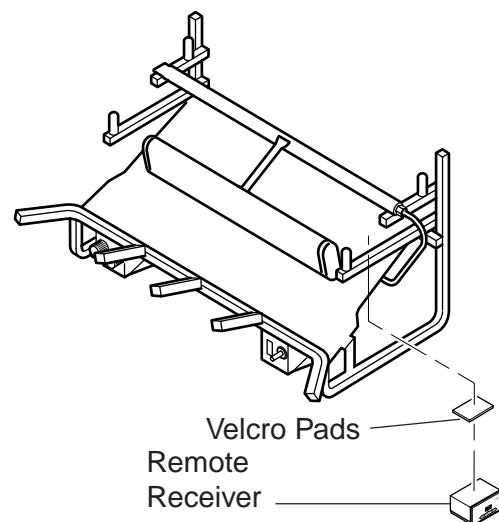

Figure 20 - Installing Remote Receiver

NOTE: Heat reduces battery life. You can protect the receiver and extend battery life by mounting the receiver in a wall or other location outside the fireplace.

CHECKING SYSTEM OPERATION

The milli-volt system and individual components may be checked with a millivolt meter having a 0-1000 mV range. Conduct each check shown in chart below by connection meter test leads to terminals as indicated.

CHECK TEST	TO TEST	CONNECT METER LEADS TO TERMINALS	THERMOSTAT CONTACTS	METER READING SHOULD BE
A	COMPLETE SYSTEM	2 & 3	CLOSED	CLOSED
B	THERMOPILE OUTPUT	1 & 2	OPEN	OPEN

A. COMPLETE MILLIVOLT SYSTEM CHECK

("A" Reading - Thermostat contacts CLOSED - Control Knob "ON" - Main burner should be come ON)

- a. If the reading is more than 100 milli-volts and the automatic valve still does not come on, replace the control.
- b. If the closed circuit reading ("A" reading) is less than 100 millivolts, determine cause for low reading, proceed to Section B below.

B. Thermopile Output Reading Check

("B" Reading - Thermostat contacts OPEN - Main burner OFF)

1. Check gas pressure to the unit. If gas pressure is within minimum and maximum on data plate, then check pilot voltage, 325 millivolts minimum. If the minimum milli-volt reading is not obtainable, replace pilot.

Before you begin — This unit is supplied with a set of three or four rustic split ceramic fiber logs. Do not handle these logs with your bare hands. **Always wear gloves to prevent skin irritation from ceramic fibers.** After handling logs, wash your hands gently with soap and water to remove any traces of fibers.

WARNING

The positioning of the logs is critical to the safe and clean operation of this heater. Sooting and other problems may result if the logs are not properly and firmly positioned in the appliance. Never add additional logs or embellishments such as pine cones, vermiculite or rock wool to the heater. Only use the logs supplied with the unit.

Failure to position the parts in accordance with diagrams below or to use only parts specifically approved for this heater may result in property damage or personal injury.

PROPER SEQUENCE OF LOG INSTALLATION

1. Install the **rear log (#3)** on the top set of locating pins. Visually check to verify the log is securely placed on the pins, and in contact with the grate.
2. Install the **front log(s) (#1 a and b)** on top of the piezo and control cover. Center the log left to right to properly engage the locator lugs. All Weathered Oak Log Sets (WO) have a two piece front log. Install the right log (longer log) per instructions above, then place the left log in front of the right log.
3. Install the **center log (#2)** behind the front log on the remaining set of locating pins. Visually check to verify the log is securely placed on the pins.
4. Install the **cross log (#4)** by engaging the holes in the cross log onto pins on the center and/or rear log.



Figure 21 - Proper Sequence of Log Installation (Golden Oak, Aged Split, Chestnut Oak, and Weathered Split Log Sets)



Figure 22 - Proper Sequence of Log Installation (Weathered Oak Set)

PLACING THE DECORATIVE ROCK

CAUTION

DO NOT sprinkle volcanic rock on the logs or around the pilot or the main burner. This may cause sooting. Only place volcanic rock on the floor of the fireplace.

During initial operation of the new heater, burning logs will give off a paper burning smell and orange flames will be present. Simply open the windows for a few hours to vent the odor.

FLAME APPEARANCE

Flames from the pilot, front and rear burner should be visually checked as soon as the heater is installed. In addition, periodically check the flames visually during operation.

CHECKING THE PILOT FLAME

The pilot flame must always be present when the heater is in operation. It should just touch the top of the thermocouple tip for natural. Refer to Figure 23 and 25 for correct pilot flame.

If the pilot flame does not touch the thermocouple, then the main burner cannot function reliably. Refer to Figure 24 and 26 for incorrect shape of pilot flame.

MILLI-VOLT CONTROL

NOTE: For illustration purposes, natural gas and propane components are combined.

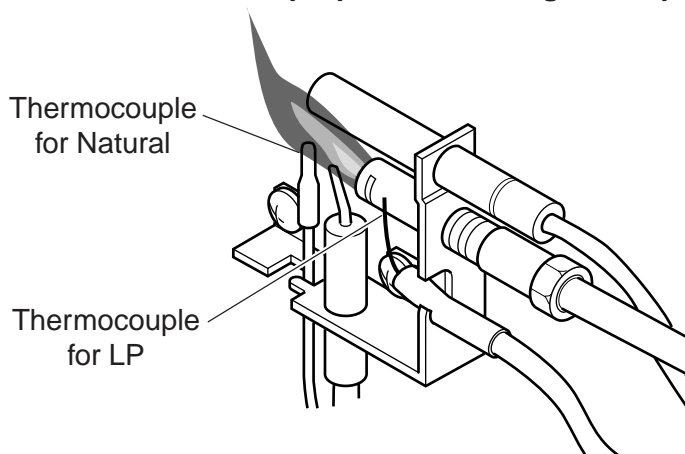

Figure 23 - Correct Appearance of Pilot Flame

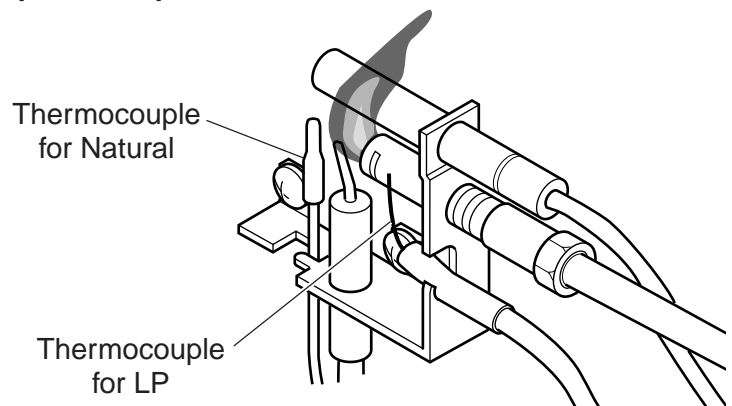

Figure 24 - Incorrect Appearance of Pilot Flame

MANUAL CONTROL AND THERMOSTAT CONTROL

NOTE: For illustration purposes, natural gas and propane components are combined.



Figure 25 - Correct Appearance of Pilot Flame

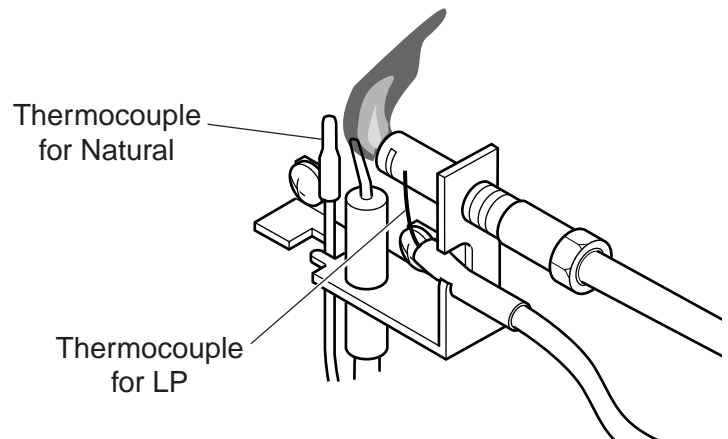

Figure 26 - Incorrect Appearance of Pilot Flame

CHECKING THE BURNER FLAME

In normal operation at full rate after 15 minutes, the following flame appearances should be observed:

The rear flames above and behind log #2, and in front of log #3, may be yellow. The flames should extend approximately 2" - 4" above log #2. Refer to Figure 27.



Figure 27 - Correct Appearance of Rear Flames

The front flames are **blue**, becoming yellowish as they hit the bumps on the face of log #2. The face of log #2 will glow a bright reddish orange when the heater is in operation.

NOTE: When the log set is turned on for the very first time, the burner flames in front of log #2 will appear an opaque orange on the surface of log #2. After two or three hours of continuous operation on the highest setting, the normal bright orange/red glow should be visible.

OPERATING INSTRUCTIONS

Avoid any drafts that alter burner flame patterns. Do not allow fans to blow directly into the fireplace. Do not place a blower inside the burn area of the firebox. Ceiling fans may create drafts that alter flame patterns. Sooting and improper burning will result.

During manufacturing, fabricating and shipping, various components of this appliance are treated with certain oils, films or bonding agents. These chemicals are not harmful, but may produce annoying smoke and smells as they are burned off during the initial operation of the appliance, possibly causing headaches or eye or lung irritation. *This is a normal and temporary occurrence.*

The initial break-in operation should last two to three hours with the burner at the highest setting. Provide maximum ventilation by opening windows or doors to allow odors to dissipate. Any odors remaining after this initial break-in will be slight and will disappear with continued use.

This appliance must not be used with glass doors in the closed position. This can lead to pilot outages and severe sooting outside the fireplace.

OPERATING INSTRUCTIONS

FOR YOUR SAFETY READ BEFORE LIGHTING

WARNING

If you do not follow these instructions exactly, a fire or explosion may result causing property damage, personal injury or loss of life.

- A.** This appliance is equipped with an ignition device which automatically lights the pilot. Do not try to light the unit by hand.
- B.** BEFORE OPERATING smell all around the appliance area for gas. Be sure to smell next to the floor because some gas is heavier than air and will settle on the floor.

WHAT TO DO IF YOU SMELL GAS:

- Do not attempt to light any appliance.
 - Do not touch any electric switch; do not use any phone in your building.
 - Immediately call your gas supplier from a neighbor's phone. Follow the gas supplier's instructions.
 - If you cannot reach your gas supplier, call the fire department.
- C.** Use only your hand to push in, or turn the gas control knob. Never use tools. If the knob will not push in or turn by hand, don't try to repair it. Call a qualified service technician. Force or attempted repair may result in a fire or explosion.
- D.** Do not use this appliance if any part of it has been under water. Immediately call a qualified service technician to inspect the appliance and to replace any part of the control system and any gas control that has been under water.



Figure 28 - Location of Piezo Ignitor and Control Knob on Manual and Thermostat Unit



Figure 29 - Location of Piezo Ignitor, On/Off Switch, and Control Knob on Milli-Volt Unit

MANUAL CONTROL LIGHTING INSTRUCTIONS

1. STOP! Read the safety information.
2. Make sure the manual shutoff valve is fully open.
3. This heater is equipped with an ignition device (piezo) which automatically lights the pilot.
4. Refer to *Figure 28, page 26* for the location of the piezo ignitor and control knob. Push in gas control knob slightly and turn control knob clockwise to the OFF position.
NOTE: Knob cannot be turned to OFF unless knob is pushed in slightly. Do not force.
5. Wait 5 minutes to clear out any gas. Then smell for gas, including near the floor. If you smell gas STOP! Follow the instructions under “WHAT TO DO IF YOU SMELL GAS”, page 26. If you do not smell gas, go to the next step.
6. From OFF position, push in gas control knob slightly and turn counterclockwise  to the IGN position. See *Figure 30*. Push in and hold control knob for 5 seconds.
NOTE: If you are running the heater for the first time, it will be necessary to press in the control knob for 30 seconds to allow air to bleed out of the gas piping.
7. With the control knob pushed in, push and release the piezo ignitor button to light the ODS pilot. The pilot is located on the right side of the heater, behind the front log and in front of the main burner. If piezo ignitor does not light the pilot, refer to “MATCH LIGHTING INSTRUCTIONS”, page 30.
8. Hold the control knob in for an additional 10 seconds to prevent the ODS pilot from shutting off the gas while the thermocouple is warming up.
9. Release the control knob.
 - If the knob does not pop out when released, stop and immediately call your service technician or gas supplier.
 - If the ODS pilot will not stay lit after several tries, push and turn the gas control knob clockwise  to OFF and wait 15 seconds. Repeat steps 6 through 9.
10. Push in control knob and turn to desired setting (LOW or HIGH). The control knob must be set at either the low or high position, and the control knob will pop out when positioned correctly. Do not set the control knob at a position between LOW and HIGH. Refer to *Figures 31 and 32*.



Figure 30 - IGN Position



Figure 31 - HIGH Position



Figure 32 - LOW Position

Wait 30 seconds before readjusting the heater when the control knob has been turned down to a lower setting.

TO TURN OFF GAS TO HEATER

1. Turn control knob clockwise  to OFF position to completely shut off the heater.
2. If applicable: Turn off all electric power to the heater.

OPERATING INSTRUCTIONS

THERMOSTATIC CONTROL LIGHTING INSTRUCTIONS

1. STOP! Read the safety information .
2. Make sure the manual shutoff valve is fully open.
3. This heater is equipped with an ignition device (piezo) which automatically lights the pilot.
4. Refer to *Figure 28, page 26* for the location of the piezo ignitor and control knob. Turn control knob clockwise  to the OFF position.
5. Wait 5 minutes to clear out any gas. Then smell for gas, including near the floor. If you smell gas, STOP! Follow safety instructions under “WHAT TO DO IF YOU SMELL GAS”, page 26. If you do not smell gas, go to the next step.
6. Turn the gas control knob counterclockwise  to the IGN position. See *Figure 33*. Push in and hold control knob for 5 seconds.
7. With the control knob pushed in and held, push and release the piezo ignitor button to light the ODS pilot. The pilot is located on the right side of the heater, behind the front log and in front of the main burner. If piezo ignitor does not light the pilot, refer to “MATCH LIGHTING INSTRUCTIONS”, page 30.
8. Hold the control knob in for an additional 10 seconds to prevent the ODS pilot from shutting off the gas while the thermocouple is warming up.
9. Release the control knob.
 - If the knob does not pop out when released, stop and immediately call your service technician or gas supplier.
 - If the ODS pilot will not stay lit after several tries, push and turn the control knob clockwise  to OFF. Release and wait 15 seconds. Repeat steps 6 through 9.
10. Turn control knob to any position between LOW and HIGH. The knob position controls the thermostat temperature. Refer to *Figure 33*.
11. The heater is now in proper operation. The following procedure should be used to achieve thermostatic control of the desired room temperature.



Figure 33 - Rotation of Control Knob

- a. Operate unit at higher setting until desired room temperature is achieved.
- b. At the desired temperature, slowly turn the knob clockwise and stop rotating when flame disappears.
- c. Thermostat is now set to maintain the current room temperature.
- d. As the room temperature decreases, the thermostat valve will open to ignite the front and rear burner.
- e. When the temperature reaches its set point (knob position), the thermostat valve will again shut off the front and rear burner.
- f. This is the normal cycle of the heater.

WARNING

Wait 30 seconds before readjusting the heater when the control knob has been turned down to a lower setting.

TO TURN OFF GAS TO HEATER

1. Turn control knob clockwise  to **OFF** position to completely shut off the heater.
2. If applicable: Turn off all electric power to the heater.

MILLI-VOLT CONTROL LIGHTING INSTRUCTIONS

1. STOP! Read the safety information label.
2. Make sure the manual shutoff valve is fully open.
3. This gas log set is equipped with an ignition device (piezo) which automatically lights the pilot. If piezo ignitor does not light the pilot, refer to instructions for “MATCH LIGHTING INSTRUCTIONS”, page 30.
4. Turn gas control knob clockwise  to the OFF position, set the thermostat to the lowest setting and turn ON/OFF switch to OFF position.
5. Wait (5) minutes to clear out any gas. Then smell for gas, including near the floor. If you smell gas, STOP! Follow "B" in the safety information label. If you don't smell gas, go to next step.
6. From OFF position, turn the gas control knob counterclockwise  to IGN position. Push in control knob for 5 seconds.
7. With the control knob pushed in, push in and release the piezo ignitor button to light the pilot.
8. Continue pushing the control knob in for an additional 60 seconds to prevent the flame detector from shutting off the gas while the probe is warming up. Release the control knob.
9. Turn gas control knob counterclockwise  to the ON position.
10. After the pilot has been lit for one minute, the burners can be turned on. Turn the ON/OFF switch to ON position or adjust thermostat to desired setting.
11. If the gas logs will not operate, follow the instructions “TO TURN OFF GAS TO APPLIANCE” below and call your service technician or gas supplier.

WARNING

Wait 30 seconds before readjusting the heater when the control knob has been turned down to a lower setting.

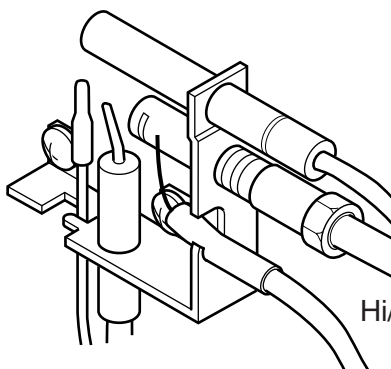

Figure 34 - Pilot



Figure 35 - Control Knobs



Figure 36 - On/Off Switch and Piezo

TO TURN OFF GAS TO HEATER

1. Turn control knob clockwise  to **OFF** position to completely shut off the heater.
2. If applicable: Turn ON/OFF switch to OFF position and/or set thermostat (if present) to lowest setting.
3. If applicable: Turn off all electric power to the heater.

OPERATING INSTRUCTIONS

MATCH LIGHTING INSTRUCTIONS

1. Remove any items necessary for easy access to the pilot (for example: logs, screens, etc.).
2. Follow appropriate lighting instructions found previously. Instead of pushing and releasing the piezo button, light a match and hold the flame to the end of the pilot and ignite the pilot.
3. After control knob has been released and pilot stays lit, reinstall any items that were removed for pilot access.
4. Call a qualified service technician for repair or replacement of the piezo ignitor.

Annual inspection and cleaning by your dealer or qualified service technician is recommended to prevent malfunction and/or sooting.

WARNING

Turn off heater and allow to cool before cleaning. Disconnect electrical power before cleaning or servicing.

Remove fireplace screen. Carefully lower screen from mounting lugs and set aside during cleaning. Refer to instruction manual for installation of screen. **DO NOT OPERATE THE UNIT WITH THE SCREEN REMOVED.**

Remove logs, handling carefully by holding gently at each end. Gloves are recommended to prevent skin irritation from ceramic fibers. If skin becomes irritated, wash gently with soap and water. Refer to manual for correct log placement.

PERIODIC CLEANING - Refer to parts diagram for location of items discussed below.

- Do not use cleaning fluid to clean logs or any part of heater.
- Brush logs with soft bristle brush or vacuum with brush attachment.
- Vacuum loose particles and dust from the front and rear burner, control and piezo covers and grate weldment.
- Inspect and clean rear burner air intake holes. Remove lint or particles with vacuum, brush or pipe cleaners. Failure to keep air intake holes clean will result in sooting and poor combustion.
- External case should be dusted and wiped with a wet soapy cloth.

ANNUAL CLEANING/INSPECTION - Refer to parts diagram for location of items discussed below.

- Inspect and clean rear burner air intake holes. Remove lint or particles with vacuum, brush or pipe cleaners. Failure to keep air intake holes clean will result in sooting and poor combustion.
- Inspect and clean all burner ports.
- Inspect ODS pilot for operation and accumulation of lint at air intake holes.
- Verify flame pattern and log placement for proper operation.
- Verify smooth and responsive ignition of main burner and rear burner.

REPLACEMENT PARTS LIST

WARNING

Failure to position the parts in accordance with these diagrams or failure to use only parts specifically approved with this appliance may result in property damage or personal injury.



REPLACEMENT PARTS LIST

REPLACEMENT PARTS ARE AVAILABLE THROUGH YOUR RETAILER.

			DLX/GLX 18		DLX/GLX 24/28	
Item	Description	Qty	Natural	Propane	Natural	Propane
Common Parts						
1	Front Burner	1	14D0435	14D0435	14D0436	14D0434
2	Rear Burner	1	14D2255	14D9055	14D2257	14D9057
3	Piezo Ignitor	1	14D0503	14D0503	14D0503	14D0503
Manual Control						
4	Control Valve	1	00K0910	00K0910	00K0910	00K0910
5	Regulator Valve	1	18D0351	18D0352	18D0351	18D0352
6	Main Injector	1	14D0566	20H0172	00K0913	14D2422
7	Rear Injector	1	14D0567	14D0563	14D0556	14D9060
8	ODS Pilot Assembly	1	14D2259	14D2262	14D2259	14D2262
9	Piezo Wire	1	00K0632	00K0632	00K0632	00K0632
10	Knob Control	1	18D0601	18D0601	18D0601	18D0601
T-Stat Control						
4	Control Valve	1	11V0701	11V0701	11V0701	11V0701
5	Regulator Valve	1	18D0351	18D0352	18D0351	18D0352
6	Main Injector	1	14D0566	20H0172	00K0913	14D2423
7	Rear Injector	1	14D0567	14D0563	14D0556	14D9060
8	ODS Pilot Assembly	1	14D2259	14D2262	14D2259	14D2262
9	Piezo Wire	1	00K0632	00K0632	00K0632	00K0632
10	Knob Control	1	18D0602	18D0602	18D0602	18D0602
Milli-volt Control						
4	Control Valve	1	14D0467	14D0468	14D0467	14D0468
5	Regulator Valve		N/A	N/A	N/A	N/A
6	Main Injector	1	14D0566	20H0172	00K0913	14D2422
7	Rear Injector	1	14D0567	14D0563	14D0533	14D9060
8	ODS Pilot Assembly	1	14D2263	14D2264	14D2263	14D2264
9	Piezo Wire	1	00K0632	00K0632	00K0632	00K0632
10	Knob Control	2	18D0603	18D0603	18D0603	18D0603
11	Switch On/Off	1	32D0232	32D0232	32D0232	32D0232

Accessories		
Connector, Flex	Flexcon 30	All Models
Switch, Wall Kit	MVWS	Millivolt only
Thermostat, Wall Kit	MVWTS	Millivolt only
Remote, Hand Held	MRC	Millivolt only
Remote, Hand Held Thermostat	TRC	Millivolt only

REPLACEMENT PARTS LIST

REPLACEMENT PARTS ARE AVAILABLE THROUGH YOUR RETAILER.

Item	Description	Qty	DLX 18	DLX 24	DLX 28
LX Golden Oak Logs					
1	Front Log	1	14D2015	14D2028	14D2038
2	Center Log	1	14D2016	14D2029	14D2039
3	Rear Log	1	14D2017	14D2030	14D2040
4	Top Log	1	14D2094	14D2018	14D2018
LX Aged Split Logs					
1	Front Log	1	14D2019	14D2031	14D2041
2	Center Log	1	14D2020	14D2032	14D2042
3	Rear Log	1	14D2021	14D2033	14D2043
4	Top Log	1	14D2093	14D2022	14D2022
LX Weathered Oak Logs					
1a	Front Left Log	1	14D2023	14D2034	14D2044
1b	Front Right Log	1	14D2024	14D2035	14D2045
2	Center Log	1	14D2025	14D2036	14D2046
3	Rear Log	1	14D2026	14D2037	14D2047
4	Top Log	1	14D2092	14D2027	14D2027
LX Chestnut Oak Logs					
1	Front Log	1	39D0800	39D0804	39D0808
2	Center Log	1	39D0801	39D0805	39D0809
3	Rear Log	1	39D0802	39D0806	39D0810
4	Top Log	1	39D0803	39D0807	39D0807
LX Weathered Split Logs			GLX 18	GLX 24	GLX 28
1	Front Log	1	26D0628	26D0632	26D0636
2	Center Log	1	26D0629	26D0633	26D0637
3	Rear Log	1	26D0630	26D0634	26D0638
4	Top Log	1	26D0631	26D0635	26D0635



LX Golden Oak Logs



LX Aged Split Logs

REPLACEMENT PARTS LIST



LX Weathered Oak Logs



LX Chestnut Oak Logs

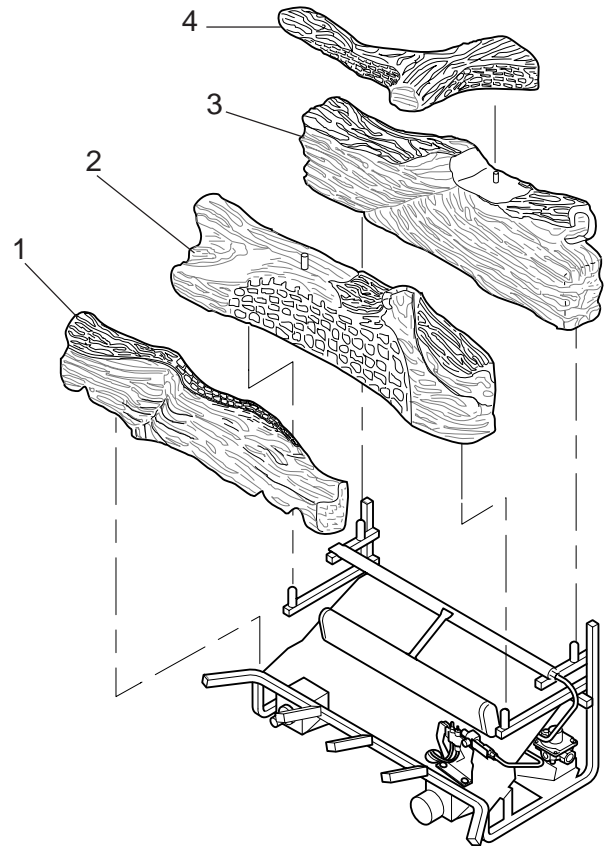

LX Weathered Split Logs

TROUBLESHOOTING

WARNING

Turn appliance OFF and allow to cool before servicing. Only a qualified service person should service and repair the heater.

Note: All troubleshooting items are listed in order of operation.

OBSERVED PROBLEM	POSSIBLE CAUSE	REMEDY
When ignitor button is pressed, there is no spark at ODS/pilot.	<ol style="list-style-type: none"> 1. Ignitor electrode positioned wrong. 2. Ignitor electrode is broken. 3. Ignitor electrode not connected to ignitor cable. 4. Ignitor cable pinched or wet. Keep ignitor cable dry. 5. Broken ignitor cable. 6. Bad piezo ignitor. 	<ol style="list-style-type: none"> 1. Replace ignitor. 2. Replace ignitor. 3. Reconnect ignitor cable. 4. Free ignitor cable if pinched by any metal or tubing. 5. Replace ignitor cable. 6. Replace piezo ignitor.
Appliance produces unwanted odors.	<ol style="list-style-type: none"> 1. Appliance burning vapors from paint, hair spray, glues, etc. 2. Gas leak. 3. Initial burn off. 	<ol style="list-style-type: none"> 1. Ventilate room. Stop using odor causing products while heater is running. 2. Locate and correct all leaks. 3. Ventilate room and turn unit on high until odor is gone. Odor should be gone after 2 to 3 hours of continuous use.
Appliance shuts off during use.	<ol style="list-style-type: none"> 1. Not enough fresh air is available for ODS/ pilot to operate. 2. Low line pressure. 3. ODS/pilot is partially clogged. 4. Defective Thermopile. 5. Restrictions in incoming air flow. 	<ol style="list-style-type: none"> 1. Open window and/or door for ventilation. 2. Contact local gas company. 3. Clean ODS/pilot. 4. Check pilot flame, check wire connections, check output, should be 325 millivolts across TH/TP and TP Terminals with ON/OFF switches off. 5. Check for bottom riser on glass door, sunken fireplace, excess lava rock/cinders densely packed against the grate.
Gas odor even when control knob is in OFF position.	<ol style="list-style-type: none"> 1. Gas leak. 2. Control valve defective. 	<ol style="list-style-type: none"> 1. Locate and correct all leaks. 2. Replace control valve.
When ignitor button is pressed, there is spark at ODS pilot, but no ignition.	<ol style="list-style-type: none"> 1. Gas supply turned off or manual shutoff valve closed. 2. Control knob not in PILOT position. 3. Control knob not pressed in while in PILOT position. 4. Air in gas lines when installed. 5. ODS/pilot is clogged. 6. Gas regulator setting is not correct. 	<ol style="list-style-type: none"> 1. Turn on gas supply or open manual shutoff valve. 2. Turn control knob to PILOT position. 3. Press in control knob while in PILOT position. 4. Continue holding down control knob. Repeat igniting operation until air is removed. 5. Replace ODS/pilot assembly or get it serviced. 6. Replace gas regulator.

WARNING

If the gas quality is bad, your pilot may not stay lit, the burners may produce soot and the heater may backfire when lit. If the gas quality or pressure is low, contact your local gas supplier immediately.

OBSERVED PROBLEM	POSSIBLE CAUSE	REMEDY
ODS/pilot lights, but flame goes out when control knob is released.	<ol style="list-style-type: none"> Control knob not fully pressed in. Control knob not pressed in long enough. Manual shutoff valve not fully open. Thermocouple connection loose at control valve. Pilot flame not touching thermocouple, which allows thermocouple to cool, causing pilot flame to go out. This problem could be caused by either low gas pressure, or a dirty or partially clogged ODS/pilot. Thermocouple damaged. Control valve damaged. 	<ol style="list-style-type: none"> Press in control knob fully. After ODS/pilot lights, keep control knob pressed in for 30 seconds. Fully open manual shutoff valve. Hand tighten until snug, then tighten 1/4 turn more. Contact local gas company. Replace thermocouple. Replace control valve.
One or both burners do not light after ODS/pilot is lit.	<ol style="list-style-type: none"> Burner orifice is clogged. Burner orifice diameter is too small. Inlet gas pressure is too low. 	<ol style="list-style-type: none"> Clean burner or replace burner orifice. Replace burner orifice. Contact qualified service person.
Burner backfires during combustion.	<ol style="list-style-type: none"> Manifold pressure is too low. Burner orifice is clogged. 	<ol style="list-style-type: none"> Contact local gas company. Clean burner or replace burner orifice.
Slight smoke or odor during initial operation.	<ol style="list-style-type: none"> Burner orifice is clogged or damaged. Burner is damaged. Gas regulator defective. 	<ol style="list-style-type: none"> Clean burner or replace burner orifice. Replace burner. Replace gas regulator.
Logs appear to smoke after initial operation.	<ol style="list-style-type: none"> Vapors from paint or curing process of logs. 	<ol style="list-style-type: none"> Problem will stop after a few hours of operation. Run the heater with the damper open if you have one, or open a window for the first few hours. Log heater is intended to be smokeless. Turn OFF heater and call qualified service person.
Heater produces a whistling noise when burner is lit.	<ol style="list-style-type: none"> Turning control knob to HIGH position when burner is cold. Air in gas line. Dirty or partially clogged burners orifice. 	<ol style="list-style-type: none"> Turn control knob to LOW position and let warm up for a minute. Operate burner until air is removed from line. Have gas line checked by local gas company. Clean burner or replace burner orifice.
No gas to pilot.	<ol style="list-style-type: none"> LP-regulator shut down due to inlet pressure too high. 	<ol style="list-style-type: none"> Verify LP tank regulator is installed and set at 11" to 13" w.c. Replace regulator on heater.

NOTES

MONESSEN HEARTH SYSTEMS

LIMITED LIFETIME WARRANTY POLICY

LIFETIME WARRANTY

The following components are warranted for life to the original owner, subject of proof of purchase: Firebox, Combustion Chamber, Heat Exchanger, Grate and Stainless Steel Burners.

FIVE YEAR WARRANTY

The following components are warranted for 5 years to the original owner, subject of proof of purchase: Ceramic Fiber Logs, Catalytic Filter and Aluminized Burners.

BASIC WARRANTY

Monessen Hearth Systems (MHS) warrants the components and materials in your gas appliance to be free from manufacturing and material defects for a period of two years from date of installation. After installation, if any of the components manufactured by MHS in the appliance are found to be defective in materials or workmanship, MHS will, at its option, replace or repair the defective components at no charge to the original owner. MHS will also pay for reasonable labor costs incurred in replacing or repairing such components for a period of two years from the date of installation. Any products presented for warranty repair must be accompanied by a dated proof of purchase.

This Limited Lifetime Warranty will be void if the appliance is not installed by a qualified installer in accordance with the installation instructions. The Limited Lifetime Warranty will also be void if the appliance is not operated and maintained according to the operating instructions supplied with the appliance, and does not extend to (1) firebox/burner assembly damage by accident, neglect, misuse, abuse, alteration, negligence of others, including the installation thereof by unqualified installers, (2) the costs of removal, reinstallation or transportation of defective parts on the appliance, or (3) incidental or consequential damage. All service work must be performed by an authorized service representative.

This warranty is expressly in lieu of other warranties, express or implied, including the warranty of merchantability of fitness for purpose and of all other obligations or liabilities. Monessen Hearth Systems, Inc. does not assume for it any other obligations or liability in connection with the sale or use of the appliance. In states that do not allow limitations on how long an implied warranty lasts, or do not allow exclusion of indirect damage, those limitations of exclusions may not apply to you. You may also have additional rights not covered in this Limited Lifetime Warranty.

MHS reserves the right to investigate any and all claims against the Limited Lifetime Warranty and decide upon method of settlement.

For information about this warranty, contact:

**Technical Services
Monessen Hearth Systems
149 Cleveland Drive
Paris, Kentucky 40361**