

This Owner's Manual is provided and hosted by [Appliance Factory Parts](#).



# Alfresco ALT724812 Owner's Manual

[Shop genuine replacement parts for Alfresco  
ALT724812](#)



[Find Your Alfresco Range Hoods Parts - Select From 1 Models](#)

----- Manual continues below -----



## INSTALLATION INSTRUCTIONS & USE & CARE GUIDE

### AL-T7200 Versa BBQ Hood Series

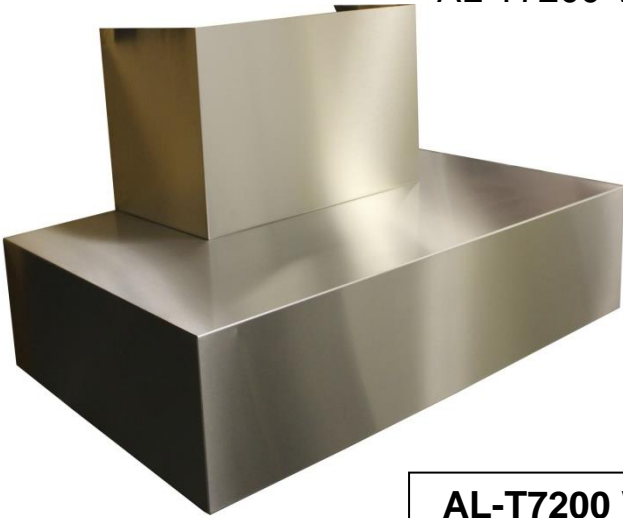

#### AL-T7200 Versa Series Models:

No Blower	1250 CFM
AL-T7236	AL-T7236-12
AL-T7242	AL-T7242-12
AL-T7248	AL-T7248-12

#### **CONTENTS:**

- Part 1 - Planning The Installation
- Part 2 - Electrical Connection
- Part 3 - Direction of Vent and Securing The Hood
- Part 4 - Use & Care

Before beginning installation, please thoroughly read and become familiar with these instructions. Installation and service must be completed by a qualified installer. Failure to properly install this product may void the warranty.

Please be advised that the Heat® AL-T7200 Series BBQ Hood MAY NOT be installed on a Patio or Lanai area that does not have a roof over the BBQ Hood to protect it from direct rain or potential water ingress. This Hood should be installed with a MINIMUM of three (3) feet of weather proof roof coverage on all sides that are not protected from direct rain by an adjacent wall.

It is required that all duct work and roof openings be thoroughly sealed with the applicable tape and/or roof sealant to prevent ingress of water.

**Installer:** Please leave Installation Instructions with the BBQ hood owner.

**Owner:** Please keep Installation Instructions for local electrical inspector's use and for future reference.



**WARNINGS:** Must be followed carefully to avoid personal injury.



**IMPORTANT:** Must be followed carefully to avoid damage or incorrect installation.



**TIPS:** Contain helpful information to facilitate installation.

## **READ AND SAVE THESE INSTRUCTIONS**



**WARNING! TO REDUCE THE RISK OF FIRE, ELECTRICAL SHOCK, OR INJURY TO PERSONS OBSERVE THE FOLLOWING:**

- a) Use this unit only in the manner intended by the manufacturer. If you have any questions, please contact the manufacturer at the address or telephone number listed in the warranty.
- b) Before servicing or cleaning unit, switch power off at service panel and lock service panel and lock the service disconnection means to prevent power from being switched on accidentally. When the service disconnecting means cannot be locked, securely fasten a prominent warning device, such as a tag to the service panel.



**CAUTION --** For general ventilating use only. Do not use to exhaust hazardous or explosive materials and vapors.



**WARNING – TO REDUCE THE RISK OF A BBQ TOP GREASE FIRE:**

- a) Never leave surface units unattended at high settings. Boilovers cause smoking and greasy spillovers that may ignite. Heat oils slowly on low or medium settings.
- b) Always turn hood ON when cooking at high heat or when flambeing food (i.e. Crepes Suzette, Cherries Jubilee, Peppercorn Beef Flambe’).
- c) Clean ventilating fans frequently. Grease should not be allowed to accumulate on fan or filter.
- d) Use proper pan size. Always use cookware appropriate for the size of the surface element.



**WARNING! TO REDUCE THE RISK OF INJURY TO PERSONS IN THE EVENT OF A BBQ TOP GREASE FIRE, OBSERVE THE FOLLOWING:**

- a) SMOTHER FLAMES with a close-fitting lid, cookie sheet, or metal tray, then turn off the burner. BE CAREFUL TO PREVENT BURNS. If the flames do not go out immediately, EVACUATE AND CALL THE FIRE DEPARTMENT.
- b) NEVER PICK UP A FLAMING PAN—YOU MAY BE BURNED.
- c) DO NOT USE WATER, including wet dishclothes or towels - a violent steam explosion will result.
- d) Use an extinguisher ONLY if:
  - 1. You know you have a Class ABC extinguisher and you already know how to operate it.
  - 2. The fire is small and contained in the area where it started.
  - 3. The fire department is being called.
  - 4. You can fight the fire with your back to an exit.
- e) Follow the barbeque grill manufacturer’s instruction when using gas grills, cookers, or any propane appliances.
- f) BE CAREFUL TO PREVENT BURNS. If the flames do not go out immediately, EVACUATE AND CALL THE FIRE DEPARTMENT.



**Recommendations:**

- 1. Consult a licensed ventilation contractor or qualified technician for proper installation of exhaust ducting. Locate the cooking area for minimum cross drafts-away from doors and windows, when possible.

2. Ducts must be of adequate size and duct runs should be as short as possible. Where turns are necessary, keep turning radius as large and as smooth as possible.
3. The ducting must be air tight. Use a minimum of 2 sheet metal screws at every duct joint. Then, seal the duct joints with high quality duct tape.
4. Do not use this unit with any solid-state speed control device.
5. This unit must be grounded.

### **INSTALLATION INSTRUCTIONS**



#### **WARNING – TO REDUCE THE RISK OF FIRE, ELECTRIC SHOCK, OR INJURY TO PERSONS, OBSERVE THE FOLLOWING:**

- a) Installation work and electrical wiring must be done by qualified person(s) in accordance with all applicable codes and standards, including fire-rated construction codes and standards.
- b) Sufficient air is needed for proper combustion and exhausting of gasses through the flue (chimney) of fuel burning equipment to prevent back drafting. Follow the heating equipment manufacturer's guidelines and safety standards such as those published by the National Fire Protection Association (NFPA) and the American Society for Heating, Refrigeration and Air Conditioning Engineers (ASHRAE) and the local code authorities.
- c) When cutting or drilling into wall or ceiling, do not damage electrical wiring and other hidden utilities.
- d) Ducted fans must always be vented to the outdoors.
- e) For safe and secure wall mounting, the HEAT<sup>®</sup> BBQ Hood should be mounted to a solid vertical surface of sufficient width to allow for mounting of the Hood. The horizontal surface should extend from a vertical plane to the point directly in front of the exhaust roof cap (or wall cap).
- f) The Hood should be installed with a MINIMUM of three (3) feet of weather proof roof coverage on all sides that are not protected from direct rain by an adjacent wall.
- g) It is also required that all duct work and roof openings be thoroughly sealed with the applicable tape and/or roof sealant to prevent ingress of water.



#### **WARNING -- TO REDUCE THE RISK OF FIRE, USE ONLY METAL DUCTWORK.**



#### **CAUTION –To reduce the risk of fire and to properly exhaust air, be sure to duct air outside – Do not vent exhaust air into spaces within walls or ceilings or into attics, crawl spaces, or garages.**

## **PART 1 Planning the Installation**



#### **CAUTION:**

1. For general ventilating use only. Do not use to exhaust hazardous or explosive materials and vapors.
2. To reduce the risk of fire and to properly exhaust air, the hood must be exhausted to outside air. Never exhaust into a wall, an attic or a concealed area in the building. This can create a potential hazard.
3. Consult a licensed ventilation contractor or qualified technician for proper installation of exhaust ducting.
4. Locate the cooking area for minimum cross drafts—away from doors and windows, when possible.

5. Ducts must be of adequate size and duct runs should be as short as possible. Where turns are necessary, keep turning radius as large and as smooth as possible.
6. The ducting must be air tight. Use a minimum of 2 sheet metal screws at every duct joint. Then, seal the duct joints with high quality duct tape.
7. Only use ductwork constructed of materials deemed acceptable by state, municipal and local codes.
8. Plan the installation so that all minimum clearances are met or exceeded. Dimensions shown provide minimum clearances, unless otherwise specified.



**IMPORTANT: All dimensions are nominal +/- 1/8".**

**FRONT VIEW**

Model #	
(No Blower)	(1250 CFM)
T7236	T7236-12
T7242	T7242-12
T7248	T7248-12

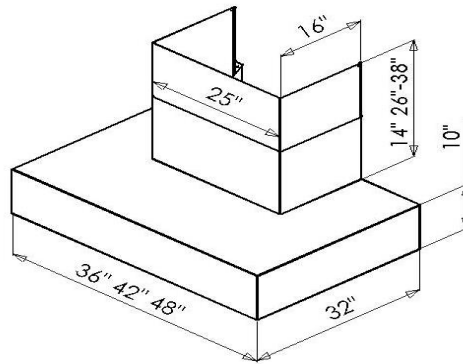

Fig. 1

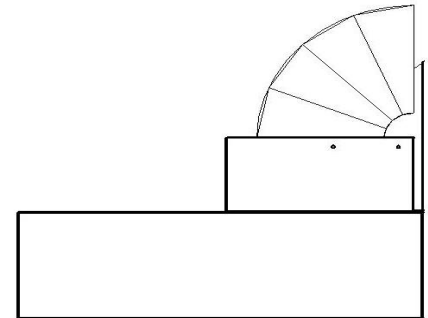

Fig. 2

\*The AL-T7200 Heat Versa Hood is extremely versatile. You can easily convert the Versa Hood to be rear discharge by attaching a 10" round elbow to the Versa Hood start collar (see Fig. 2). DO NOT USE flex duct as it can create turbulence and diminish the hood's performance. Use a high quality foil duct tape to seal the connection and avoid vibration. Be sure to mount the Versa Hood with adequate clearance from ceiling to allow for height of elbow used for rear discharge. These 10" elbows can be purchased at many Home and Hardware stores for a nominal cost.

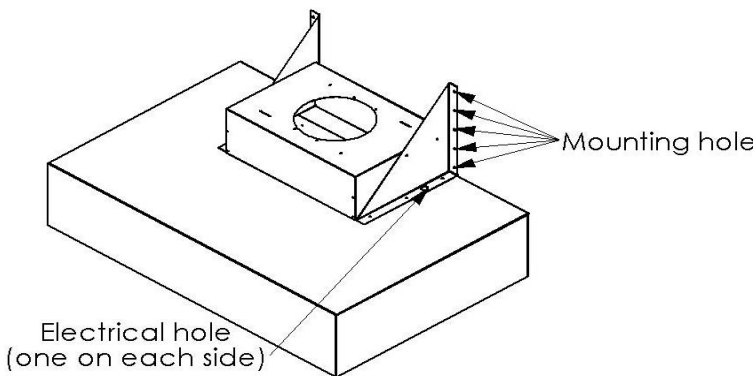

Fig. 3

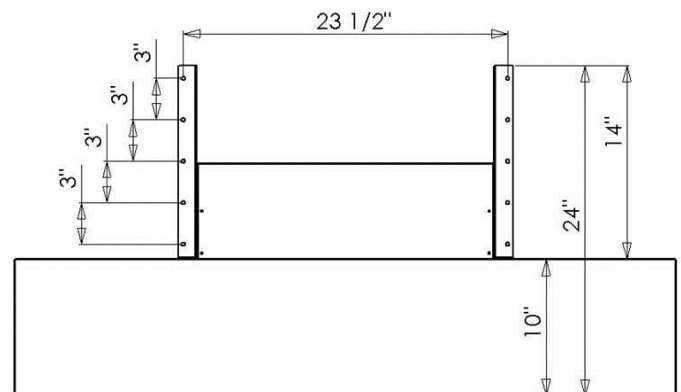

Fig. 4





**WARNING! Following are Manufacturer's Suggestions. Always Observe Local Building Codes.**

Hoods installed in custom canopies constructed of combustible materials should be installed with the combustible material structure a minimum of 36" above the cooking surface. Hoods installed in custom canopies constructed of non-combustible materials, should be installed with the non-combustible material structure a minimum of 30" above the cooking surface. Follow all instructions regarding minimum safe clearances and installation location. Failure to do so may result in a safety hazard or fire. To reduce the risk of fire use only metal ductwork.

**PART 2 Mounting and Securing the Hood**

**MOUNTING HOLES:**

Because of the low profile and weight of the AL-T7200 BBQ hood, 2 heavy duty triangular mounting brackets are provided (see Fig. 3). This will **require** wood backing in the wall for support to lag bolt the brackets to. Brackets are pre-mounted to the hood (see Fig. 4 for location of bracket holes for the wall). Blocking should cover behind all holes and extend from stud to stud.

After the hood is mounted and being held by the mounting brackets, several holes may be drilled across the back of the hood. This is to hold the hood firmly against the wall. These would be located half way up the hood, evenly spaced out across the back.

**PART 3 Electrical Connection**



**WARNING!**

Ensure that the power supply is disconnected before proceeding. Verify that the power supply matches the ratings found on the appliance data label before proceeding. The complete appliance must be properly grounded at all times when electrical power is applied. Do not ground the appliance with the neutral (white) house supply wire. A separate ground wire must be utilized. Failure to complete electrical connections properly may result in damaged or non-functional systems. Follow instructions carefully to ensure proper installation.

**It is the owner's responsibility to ensure that a qualified person performs the electrical connection of this appliance. The electrical installation, including minimum supply wire size, must comply with the National Electric Code ANSI/NFPA 70-1990 (or latest revision) and local codes and ordinances. A copy of this standard may be obtained from:**

National Fire Protection Association, 1 Batterymarch Park, Quincy, Massachusetts 02169-7471

**Important Electrical Requirements:** Observe all National and local governing codes and ordinances. Have all electrical installation done by a qualified electrical installer. This Hood requires a 120 Volt, 60 Hertz electrical supply of an individual properly grounded branch circuit protected by a 15 or 20 Amp circuit breaker. The HEAT® AL-T7200 Series BBQ Hood is supplied with a 6.0 Amp three speed fan control.

**For safety precautions, each Ventilation Hood should be installed in a GFCI protected branch circuit.**



**INSTRUCTIONS:**

Wire connections: (See Diagram Below)  
There are 3 wires on the front panel that require connection.

BLACK	120 VAC from electrical panel (usually black)
WHITE	Neutral from electrical panel (white)
GREEN	Ground from electrical panel (usually green)



**CAUTION:**

The neutral wire (white) must only be connected to the white neutral wire coming in from the electrical panel.



### House Electrical Panel

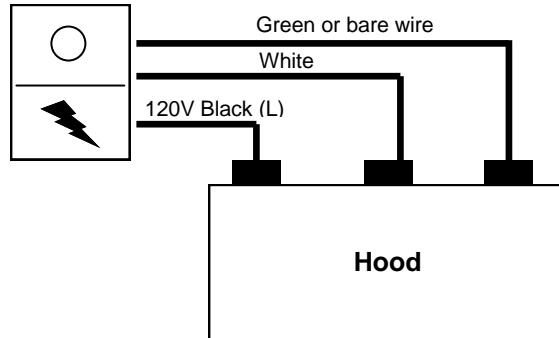

Fig. 5

## PART 4 Use and Care

### OPERATING CONTROLS:

Always activate the ventilator when using cooking appliances. Activate the ventilator a few minutes before starting to cook to establish an airflow pattern within the room. Adjust the fan speed as needed. Adjust the dimmable halogen lights as desired.



### WARNING!

Do NOT operate the blower / ventilator system without the filters in place, or with dirty, grease laden filters.



### ENERGY SAVING TIPS:

Do not operate the blower at a speed higher than necessary to remove the cooking exhaust. Turn off the unit once the smoke and cooking odors have been eliminated. Clean filters and grease laden surfaces often to improve efficiency.



### CARE & CLEANING:

Proper cleaning is necessary to maintain performance and appearance, while also ensuring safe operation. The frequency of cleaning should be adjusted according to the type and amount of cooking. Best results will be achieved by cleaning soiled components as soon as possible. Filters must be cleaned regularly. The commercial-style baffle filters should have the long slots running front to back.

The filters may be cleaned by hand washing in hot water using a mild detergent solution, or by placing them in a dishwasher. Dry the filters completely before using again. Stainless steel surfaces should be cleaned with a solution of mild detergent and warm water. Rinse and dry with a soft lint-free cloth.



### CAUTION:

If a commercially available stainless steel cleaner is used, it is important to read the labels for chlorine compounds. Chlorine is a corrosive substance. If these compounds are present, rinse thoroughly and dry with a soft lint-free cloth. Follow polish manufacturer's instructions. Always wipe stainless steel surfaces with the grain. Never wipe across the grain. After cleaning, reinstall the filters carefully.

**>> Most common scrubber type pads will scratch the hood.**



### HALOGEN LIGHT BULBS:

Hoods are designed for halogen light bulbs. They can be purchased at most home and/or grocery stores,

**We endeavor to incorporate the best technology provided to our industry, in manufacturing the HEAT® products, therefore, we reserve the right to change models, mode of operation, and specification without prior notice.**



# WARRANTY

## **HEAT AL-T7200 Versa BBQ Hood Ventilation Products**

### What is Covered

**Heat Outdoor Living** warrants its **HEAT**<sup>®</sup> AL-T7200 Series BBQ Hood ventilation products to the original user, to be free of defects in materials and workmanship for three (3) years from the date of purchase.

**Heat Outdoor Living**, at its option, will repair or replace the complete unit or any defective component without charge. This warranty may be voided if any unauthorized service, alterations, or repairs are made to the product.

### What is Not Covered

- Normal maintenance and service of any product that has been subject to misuse, negligence, accident or installation inconsistent with the recommended installation instructions.
- Product used other than for normal in-home use or products used outside of the United States.
- Damage to the product caused by accident, fire, flood or other acts of God.
- Service calls to educate the customer in the proper use and care of the product, change fuses or reset breakers.
- Service calls to correct faulty installation, such as, performance issues relating to improperly sized ducting or restrictive roof caps.

**Heat Outdoor Living** disclaims and excludes any liability for implied warranties or for incidental or consequential damages wherever permitted by law. There are no implied warranties of merchantability or fitness for a particular use or purpose. This warranty gives you specific legal rights and you may also have other rights, which vary from state to state.

### For Service

If you need service, contact Customer Service at the address or phone number below. Provide the model number, serial number and/or details of the problem. Proof of purchase must be provided.

Warranty Revised 09-01-2015

**Heat Outdoor Living** has a policy of continuous improvements and reserves the right to modify (at any time and without notice) any or all of its products, features, designs, components and specifications. Some features may be slightly different than shown on product literature.



For more information, please contact your **HEAT** Representative

Heat Outdoor Living  
PO Box 16262  
Philadelphia, PA 19114  
877-397-5144 or [consumerservice@heatoutdoorliving.com](mailto:consumerservice@heatoutdoorliving.com)  
[www.heatoutdoorliving.com](http://www.heatoutdoorliving.com)



# Performance Guidelines

 **IMPORTANT:** Problems caused by improper installations are not covered by the manufacturer's warranty.

 **IMPORTANT:** Undersized and improperly installed duct pipe and/or other ventilation components will cause excessive static pressure (air resistance), that may result in rattling, vibration and air buffeting noises, as well as inadequate ventilation.

## 1. Building Codes

BBQ Hood Ventilators should be installed by qualified technicians familiar with state and local building codes.

## 2. Duct Pipe and Fittings (Elbows, Transitions, Roof & Wall Caps)

- a. Use round or rectangular rigid metal duct only. Where possible, use round duct as it creates the least amount of static pressure. DO NOT use flex duct.
- b. All duct sections and fittings (EXCEPT DAMPERS, per Section 4), should overlap and be connected with at least 3 – 4 equally spaced screws and wrapped tightly with 2 – 3 layers of Aluminum Foil Metal Duct Tape. This type of duct tape is more durable than traditional cloth duct tape. DO NOT use butt joints.
- c. For best air flow, elbows and pipe size transition fittings should not be directly connected to one another. Where possible, always include at least 15 inches of straight pipe between fittings.

## 3. Duct Pipe and Fitting Sizes

 **IMPORTANT:** No portion of any length of duct pipe or fitting should be smaller than the discharge port of the ventilator. This is very important because any type of restriction anywhere in the ventilation system will cause increased static pressure (air resistance), that may result in rattling, vibration and air buffeting noises, as well as inadequate ventilation. See [Duct Sizing Chart and Area Calculations](#) section for more detail.

### Duct Runs – Length

- a. Configure the ventilation duct run to be as short and as direct to the outside as possible. Minimize the number of elbows and transition fittings used. Complex or long runs should be reviewed by a qualified installer.
- b. No portion of the ducting should be run so that the exhaust air flows downward. Since exhaust heat rises, forcing the air to flow downward will cause increased static pressure. As previously mentioned, improperly installed duct pipe will cause excessive static pressure (air resistance), that may result in rattling, vibration and air buffeting noises, as well as inadequate ventilation.
- c. Duct runs for 1250CFM ventilator models should not exceed 35 linear feet with two 90-degree elbows and two 45-degree elbows, and a roof or wall cap. Longer runs or additional elbows will result in decreased ventilation performance. Each 90-degree elbow is the equivalent of 6 linear feet of duct pipe; each 45-degree elbow is equivalent to 3 linear feet of duct pipe.
- d. Always run ventilator ducts to the outdoors. DO NOT terminate a duct into an attic, basement, garage, crawl space under a house, a chimney, other ducting or an enclosed room.

## 5. Dampers

 **IMPORTANT:** DO NOT USE ANY TYPE OF DAMPER IN A BBQ HOOD APPLICATION.

In ventilation systems utilizing a roof cap or wall cap with a built-in damper, remove it. Dampers are unnecessary and will cause increased static pressure (air resistance), that may result in rattling, vibration and air buffeting noises, as well as inadequate ventilation.

## 6. Roof Caps and Wall Caps

 The roof cap or wall cap is the termination point of the venting system that allows the exhaust air to exit to the outdoors. All sections of this fitting must have an equal or greater air path area than the ventilator's discharge port. If any section of the roof cap or wall cap is smaller than the ventilator's discharge port, the entire ventilation system will lose efficiency and the restriction will cause

increased static pressure and decrease performance.

**IMPORTANT:** Even though the intake side of the roof cap or wall cap may be properly sized, roof caps or wall caps need to have the actual open area of the final air path that is equal to or greater than the discharge port of the hood. Any undersized portion of a roof cap or wall cap will cause excessive static pressure that may result in rattling, vibration and air buffeting noises, as well as inadequate ventilation.

**Do Not** use “goose-neck style” caps as they significantly restrict natural, heated air-flow. **Do Not** use caps with dampers for BBQ Hoods.

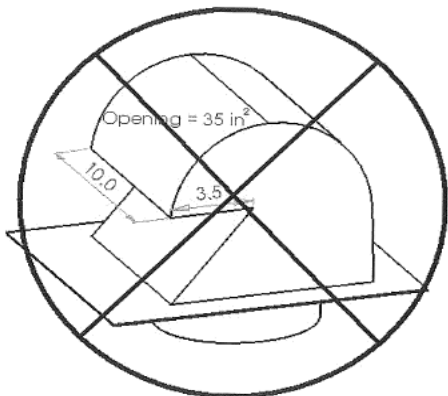

Fig. 1

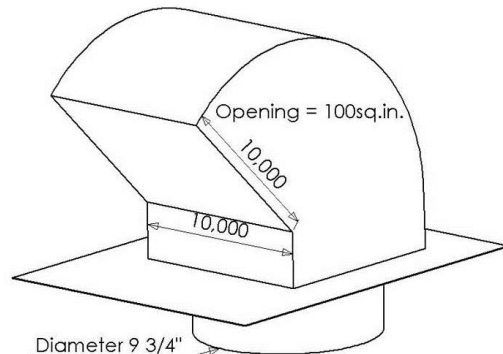

Fig. 2

The air exit opening on the roof cap used needs to be at or above 78.5 square inches. See illustrations above. **Never** use a roof cap like the one shown in Figure 1. Instead use a style similar to the one shown in Figure 2.

### 7. Attaching Duct to House Framework

The ventilation system should be attached to the framework in such a manner that the weight of the duct and fittings is supported with no stress on the duct joints, fittings or on the ventilator. All ducting should be attached so as to avoid any possible duct vibration from being transferred to the house’s framework.

### 8. Duct Sizing Chart and Area Calculations

Ventilator Discharge Port Types & Sizes	Duct Type Required	Minimum Duct Size (in Square Inches)	Minimum Discharge Size of Roofcap or Wallcap Outside Opening
10" Diameter, Round (Area is 78.5 Square Inches)	10" Round Metal Duct or	78.5"	78.5"
	8" x 10" Rectangular Duct	80"	80"

#### Formulas for Calculating Square Inches of Various Duct Sizes & Types

ROUND DUCT						
Radius	x	Radius	x	3.1416	=	Area (Sq. Inches)
	x		x		=	

The “radius” is one-half the diameter of a round duct, e.g., ½ of a 10” round duct is 5”. 3.1416 is “Pi”, the “constant” used when calculating the area of a circle.

RECTANGULAR DUCT				
Width	x	Depth	=	Area (Sq. Inches)
	x		=	



## 9. Best Smoke Capture Recommendations

Smoke and hot air from an Outdoor BBQ Grill rises quickly, especially as the BBQ lid is opened. Not only does the smoke rise fast, but it is usually deflected forward away from the front of the hood and beyond the BBQ hood's capture area by the shape and position of the BBQ lid itself. Dense, fast rising smoke is a challenge even for high-performance BBQ hoods, but there are some things you can do to enhance your outdoor BBQ hood's performance.

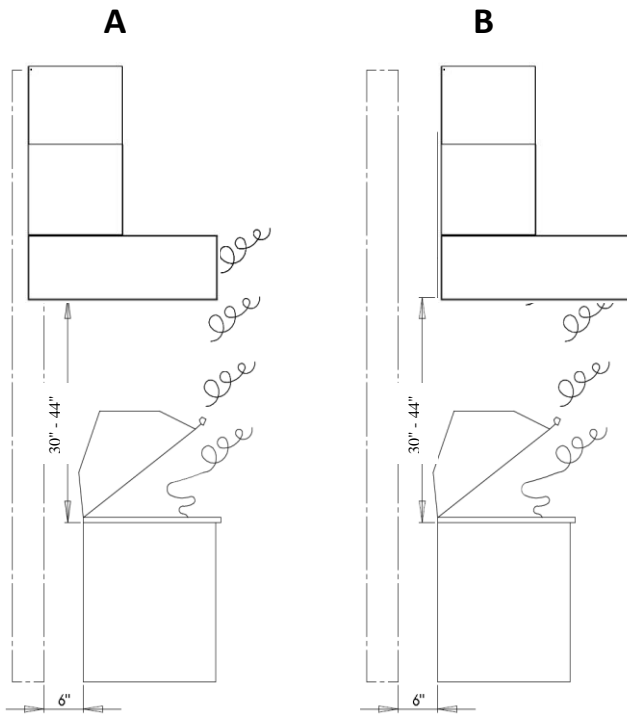

will help capture much of the smoke.

- Install the hood at least 30", but no more than 44" above the cooking surface. If the hood is installed more than 44" above the cooking surface, its' smoke capture ability declines rapidly. See Drawing A.
- Since smoke also expands as it rises, the hood's sides and front edge should extend 3" – 6" beyond the front and sides of the cooking surface—see Drawing B. In this example, the hood is attached to a built-out section of the wall or to a chase.

It is unlikely that smoke rising past the bottom of the BBQ hood will be captured by the hood. Smoke escaping the hood's capture area will typically remain against the ceiling until it is blown out by natural air currents or until it dissipates.

- Turn the hood on high upon starting the grill and prior to placing food on the grill. If there is no wind or wind drafts, an upward flowing air "curtain" will be created by the hood's suction that moves air up the sides and front of the cooking surface. This upward moving air curtain
- Wind and wind drafts will also negatively affect the capture ability of high-performance outdoor BBQ hoods. If the BBQ grill is located in a consistently windy area, e.g., near oceans, large lakes or on hillside properties, a wind-break may be required for best BBQ hood performance.