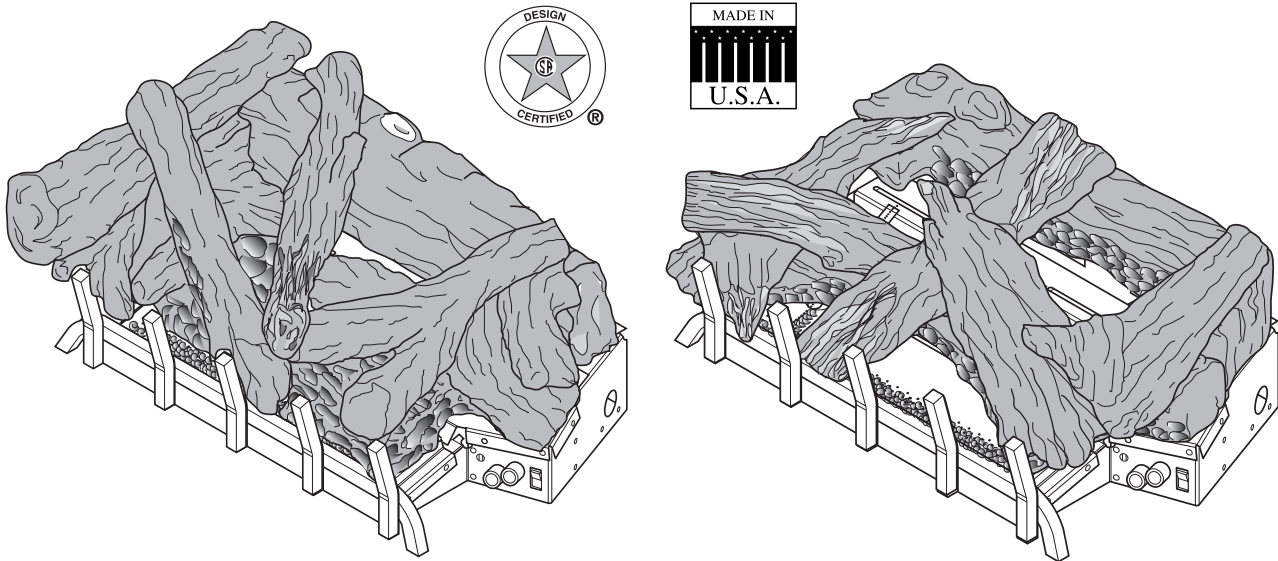


# UNVENTED GAS LOG HEATER OR VENTED DECORATIVE APPLIANCE INSTALLATION AND OPERATING INSTRUCTIONS



**MODELS: HVFL18 and HVFL24**

**Natural Gas or Propane/LPG  
Control Type: Manual and Milli-Volt**

This appliance may be installed in an aftermarket, permanently located, manufactured (mobile) home, where not prohibited by local codes.

This appliance is only for use with the type of gas indicated on the rating plate. This appliance is not convertible for use with other gases.

This is an unvented gas-fired heater. It uses air (oxygen) from the room in which it is installed. Provisions for adequate combustion and ventilation air must be provided. Refer to page 8.

## WARNINGS

If the information in this manual is not followed exactly, a fire or explosion may result causing property damage, personal injury or loss of life.

- Do not store or use gasoline or other flammable vapors and liquids in the vicinity of this or any other appliance.
- **WHAT TO DO IF YOU SMELL GAS**
  - Do not try to light any appliance.
  - Do not touch any electrical switch; do not use any phone in your building.
  - Immediately call your gas supplier from a neighbor's phone. Follow the gas supplier's instructions.
  - If you cannot reach your gas supplier, call the fire department.
- Installation and service must be performed by a qualified installer, service agency or the gas supplier.

**READ AND SAVE THESE INSTRUCTIONS**

---

# CONTENTS

---

<b>Important Safety Information</b> .....	<b>3</b>	<b>Electrical Wiring (Milli-volt)</b> .....	<b>22</b>
<b>Getting Started</b> .....	<b>5</b>	Connecting Remote Receiver.....	23
<b>Product Features and Specifications</b> .....	<b>6</b>	Installing Thermostat Sensor .....	23
Natural Gas .....	6	Operation of Thermostat Sensor .....	25
Propane/LP.....	6	<b>Rock Wool and Log Placement</b> .....	<b>26</b>
Ignition Controls.....	7	Kentucky Stack.....	26
Pilot.....	7	Split Maple.....	28
Thermal Generator .....	7	<b>Flame Appearance</b> .....	<b>30</b>
<b>General Installation Information</b> .....	<b>7</b>	Milli-Volt/Thermostat Control .....	30
Codes .....	7	Manual Control .....	30
Adequate Combustion and Ventilation Air .....	7	<b>Checking Burner Flames</b> .....	<b>31</b>
<b>Fireplace and Hearth Dimensions</b> .....	<b>10</b>	<b>Operating Instructions</b> .....	<b>32</b>
<b>Placement in a Fireplace with a Restrictive Barrier</b> .....	<b>11</b>	For Your Safety Read Before Lighting .....	32
<b>Clearances and Height Requirements</b> .....	<b>12</b>	Manual Control Lighting Instructions .....	33
<b>Floor Clearance</b> .....	<b>17</b>	Milli-Volt/Thermostat Control Lighting Instructions.....	34
<b>Fireplace Preparation</b> .....	<b>18</b>	Match Lighting Instructions .....	35
<b>Installing Vented Applications</b> .....	<b>19</b>	<b>Cleaning Instructions</b> .....	<b>35</b>
<b>Connecting the Gas</b> .....	<b>20</b>	<b>Troubleshooting</b> .....	<b>36</b>
<b>Checking Gas Pressure</b> .....	<b>21</b>	<b>Replacement Parts</b> .....	<b>38</b>
Manual Control .....	21	Burner Assembly .....	38
Milli-Volt/Thermostat Control .....	21	Logs.....	40
		<b>Warranty</b> .....	<b>Back page</b>

## IMPORTANT SAFETY INFORMATION

### INSTALLER

Please leave these instructions with the appliance.

### OWNER

Please retain these instructions for future reference.

### IMPORTANT

Read these instructions carefully before installing or trying to operate this vent-free gas heater.

### WARNING

- **Any change to this heater or its controls can be dangerous.**
- **Improper installation or use of the heater can cause serious injury or death from fire, burns, explosion or carbon monoxide poisoning.**
- **Do not allow fans to blow directly into the fireplace. Avoid any drafts that alter burner flame patterns.**
- **Do not use a blower insert, heat exchanger insert or other accessory, not approved for use with this heater where applicable.**

1. Due to high temperatures, the appliance should be located out of traffic and away from furniture and draperies.
2. Children and adults should be alerted to the hazard of high surface temperature and should stay away to avoid burns or clothing ignition.
3. Young children should be carefully supervised when they are in the same room with the appliance.
4. Do not place clothing or other flammable material on or near the appliance.
5. Any safety screen or guard removed for servicing an appliance, must be replaced prior to operating the heater.
6. Installation and repair should be done by a qualified service person.
7. To prevent malfunction and/or sooting, an unvented gas heater should be cleaned before use and at least annually by a professional service person. More frequent cleaning may be required due to excessive lint from carpeting, bedding material, etc. It is imperative that control compartments, burners and circulating air passageways be kept clean.
8. **CARBON MONOXIDE POISONING:** Early signs of carbon monoxide poisoning are similar to the flu with headaches, dizziness and/or nausea. If you have these signs, obtain fresh air immediately. Have the heater serviced as it may not be operating properly.
9. The installation must conform with local codes or, in the absence of local codes, with the **National Fuel Gas Code, ANSI Z223.1/NFPA54.**
10. This unit complies with ANSI Z21.11.2-2001 Unvented Heaters and also complies with ANSI Z21.60-2000 Decorative Vented Appliances for Solid Fuel Burning Fireplaces. State and local codes may only allow operation of this appliance in a vented configuration. Check your state or local codes. For vented operation, see "*Vented Instructions*" in this manual.
11. Do not install the heaters in a bathroom or bedroom.
12. Correct installation of the ceramic fiber logs, proper location of the heater, and annual cleaning are necessary to avoid potential problems with sooting. Sooting, resulting from improper installation or operation, can settle on surfaces outside the fireplace. See log placement instructions for proper installation.
13. Avoid any drafts that alter burner flame patterns. Do not allow fans to blow directly into fireplace. Do not place a blower inside burn area of firebox. Ceiling fans may create drafts that alter burner flame patterns. Sooting and improper burning will occur.
14. **Caution:** Candles, incense, oil lamps, etc. produce combustion byproducts including soot. Vent-free appliances will not filter or clean soot produced by these types of products. In addition, the smoke and/or aromatics (scents) may be reburnt in the vent-free appliance which can produce odors. It is recommended to minimize the use of candles, incense, etc. while the vent-free appliance is in operation.
15. This is an unvented gas-fired heater. It uses air (oxygen) from the room in which it is installed. Provisions for adequate combustion and ventilation air must be provided. See page 8.

Continued on page 4

## IMPORTANT SAFETY INFORMATION

*Continued from page 3*

16. Keep room area clear and free from combustible materials, gasoline and other flammable vapors and liquids.
17. Unvented gas heaters are a supplemental zone heater. They are not intended to be the primary heating appliance.
18. Unvented gas heaters emit moisture into the living area. In most homes of average construction, this does not pose a problem. In houses of extremely tight construction, additional mechanical ventilation is recommended.
19. During manufacturing, fabricating and shipping, various components of this appliance are treated with certain oils, films or bonding agents. These chemicals are not harmful but may produce annoying smoke and smells as they are burned off during the initial operation of the appliance; possibly causing headaches or eye or lung irritation. This is a normal and temporary occurrence.
20. Input ratings are shown in BTU per hour and are for elevations up to 2,000 feet. For elevations above 2,000 feet, input ratings should be reduced 4 percent for each 1,000 feet above sea level. Refer to the National Fuel Gas Code.
21. The appliance and its appliance main gas valve must be disconnected from the gas supply piping system during any pressure testing of that system at test pressures in excess of 1/2 psig (3.5 kPa).
22. The appliance must be isolated from the gas supply piping system by closing its equipment shutoff valve during any pressure testing of the gas supply piping system at test pressures equal to or less than 1/2 psig (3.5 kPa).
23. Do not use this room heater if any part has been under water. Immediately call a qualified service technician to inspect the room heater and to replace any part of the control system and any gas control which has been under water.
24. This appliance must not be used with glass doors in the closed position. This can lead to pilot outages and severe sooting outside the fireplace.
25. Never burn solid fuels in a fireplace where a unvented room heater is installed.
26. Always have a fireplace screen in place when the appliance is in operation and, unless other provisions for combustion air are provided, the screen must have an opening(s) for induction of combustion air.

**WARNING**

**Never connect unit to private (non-utility) gas wells. This gas is commonly known as wellhead gas.**

The initial break-in operation should last two to three hours with the burner at the highest setting. Provide maximum ventilation by opening windows or doors to allow odors to dissipate. Any odors remaining after this initial break-in period will be slight and will disappear with continued use.



We suggest that our gas hearth products be installed and serviced by professionals who are certified in the U.S. by the National Fireplace Institute® (NFI) as Gas Specialists.

### MAKE SURE YOU HAVE RECEIVED ALL PARTS:

Check your packing list to verify that all listed parts have been received. You should have the following:

- Unvented gas log grate/burner assembly
- Two (2) plastic bags containing crushed volcanic rock
- Installation/operating instructions
- Four (4) anchoring screws
- Ceramic fiber logs / Refractory logs
- Rock wool

The milli-volt controlled version of this heater is the only style designed to be operated with optional devices for ON/OFF functions. The following options may be used with the milli-volt controlled heater. These options are not packaged with the log set.

- Hand held Remote with receiver
- Wall thermostat with 15' wire
- Hand held Thermostat Remote with receiver
- Thermostat sensor

### CAUTION

- **Handle the gas log burner assembly by the burner only. Do not pick the unit up by the burners.**
- **Gloves are recommended when handling ceramic fiber logs to prevent skin irritation from loose fibers. Logs are fragile — handle with care.**

Carefully inspect the contents for shipping damage. If any parts are missing or damaged, immediately inform the dealer from whom you purchased the appliance. **Do not attempt to install any part of the appliance unless you have all parts in good condition.**

### WHAT YOU WILL NEED FOR INSTALLATION:

You should have the following items available before proceeding with installation:

- External regulator (for propane/LPG and 1/2 lb. natural gas systems only)
- Piping which complies with local codes
- Sediment trap (recommended)
- Screwdriver
- Tee joint.
- Pipe sealant approved for use with propane/LPG (Resistant to sulfur compounds)
- Drill with 5/32 bit
- Pipe wrench or appropriate size crescent wrench set
- Manual shutoff valve

## PRODUCT FEATURES AND SPECIFICATIONS

### NATURAL GAS

**NOTE:** An external regulator is required to reduce supply pressure to a maximum of 10 1/2" W.C. on natural gas systems operating at higher pressure.

#### Manual Pressure

Regulator Pressure Setting: 4.0" w.c.

Gas Inlet Pressure: Max. 10 1/2" w.c.  
Min. 5" w.c.

#### Milli-Volt

Regulator Pressure Setting: 3.5" w.c.

Pilot Regulator: 3.5" w.c.

Gas Inlet Pressure: 10 1/2" w.c.  
Min. 5" w.c..

Model Number	Control	Gas Rate	
		Max BTU/Hr	Min BTU/Hr
HVFL18NM	MANUAL	28,000	18,000
HVFL18NV	MILLIVOLT	28,000	20,000
HVFL24NM	MANUAL	36,000	20,000
HVFL24NV	MILLIVOLT	36,000	24,000

### PROPANE/LPG

**Note:** An external regulator is required to reduce supply pressure to a maximum of 13" w.c.

#### Manual Pressure

Regulator Pressure Setting: 10" w.c.

Gas Inlet Pressure: Max. 13" w.c.  
Min. 11" w.c.

#### Milli-Volt

Regulator Pressure Setting: 10" w.c

Gas Inlet Pressure: Max. 13" w.c.  
Min. 11" w.c..

Model Number	Control	Gas Rate	
		Max BTU/Hr	Min BTU/Hr
HVFL18PM	MANUAL	28,000	18,000
HVFL18PV	MILLIVOLT	28,000	20,000
HVFL24PM	MANUAL	36,000	24,000
HVFL24PV	MILLIVOLT	36,000	27,000

### IGNITION CONTROLS

Piezo ignitor allows ignition of the pilot without the use of matches or batteries.

**Manual control has three (3) positions:**

- OFF** - All gas to the gas logs is shut off at the valve.
- IGN** - Valve position to light/maintain a standing pilot.
- HI/LOW** - Variable position corresponding to desired flame height.

**Milli-Volt control has four (4) positions:**

- OFF** - All gas to the gas logs is shut off at the valve.
- IGN** - Valve position to light/maintain a standing pilot.
- ON** - Valve position to turn ON/OFF log set with remote switch/thermostat.
- LOW/HI** - Variable position to control flame height (heat output).

### PILOT/ODS

The gas log heater is fitted with a specially designed safety pilot (ODS assembly) which senses the amount of oxygen available in the room and shuts the gas log heater off if the oxygen level begins to drop below a satisfactory level. The pilot can only be relit when adequate fresh air is available.

### THERMAL GENERATOR

The millivolt gas log pilot is fitted with a milli-volt (thermopile) generator to provide power for remote activation.

---

## GENERAL INSTALLATION INFORMATION

---

### CODES

Adhere to all local codes or, in their absence, the latest edition of THE NATIONAL FUEL GAS CODE ANSI Z223.1 or NFPA54 which can be obtained from...

**American National Standards Institute, Inc.**

1430 Broadway  
New York, NY 10018

or

**National Fire Protection Association, Inc.**

Batterymarch Park  
Quincy, MA 02269

### ADEQUATE COMBUSTION AND VENTILATION AIR

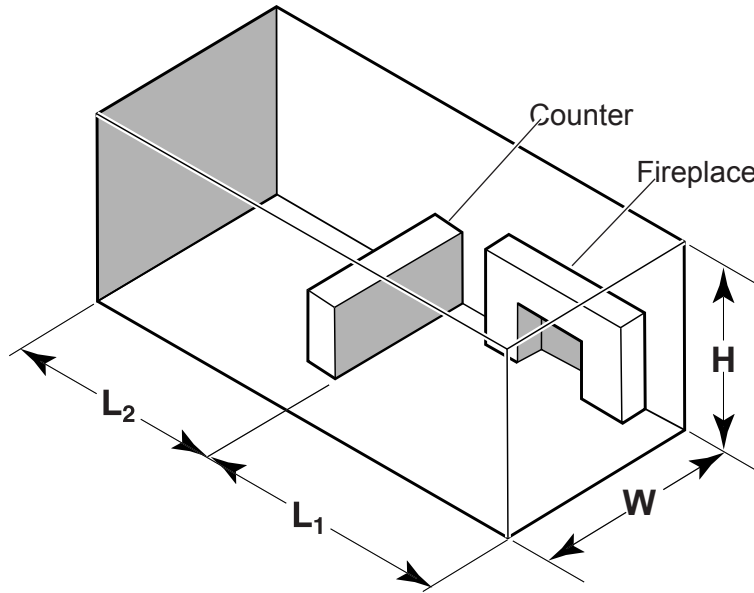
This heater shall not be installed in a confined space or unusually tight construction unless provisions are provided for adequate combustion and ventilation air.

**The National Fuel Gas Code, (ANSI Z223.1/NFPA 54)**, defines a confined space as a space whose volume is less than 50 cubic feet per 1,000 BTU per hour (4.8 m<sup>3</sup> per kw) of the aggregate input rating of all appliances installed in that space. An unconfined space is defined as a space whose volume is not less than 50 cubic feet per 1,000 BTU per hour (4.8 m<sup>3</sup> per kw) of the aggregate input rating of all appliances installed in that space. Rooms communicating directly with the space in which the appliances are installed, through openings not furnished with doors, are considered a part of the unconfined space.

### UNUSUALLY TIGHT CONSTRUCTION IS DEFINED AS CONSTRUCTION WHERE...

- a) walls and ceilings exposed to the outside atmosphere have a continuous water vapor retarder with a rating of 1 perm (6 x 10<sup>11</sup> kg per pa-sec-m<sup>2</sup>) or less with openings gasketed or sealed;
- b) weather striping has been added on openable windows and doors, and
- c) caulking or sealants are applied to areas such as joints around window and door frames, between sole plates and floors, between wall-ceiling joints, between wall panels, at penetrations for plumbing, electrical, and gas lines, and at other openings.





**Figure 1 - Example of a Large Room with 1/2 Wall Divider**

The following formula can be used to determine the maximum heater rating per the definition of unconfined space:

$$\frac{\text{BTU/Hr} = (L_1 + L_2) \text{ Ft} \times (W) \text{ Ft} \times (H) \text{ Ft}}{50} \times 1000$$

Consider two connecting rooms with an open area between, with the following dimensions:

$$L_1 = 15\frac{1}{2} \text{ Ft.}, L_2 = 12 \text{ Ft.}, W = 12 \text{ Ft.}, H = 8 \text{ Ft.}$$

$$\frac{\text{BTU/Hr} = (15\frac{1}{2} + 12) \times (12) \times (8)}{50} \times 1000 = 52800 \text{ BTU/Hr}$$

If there were a door between the two rooms the calculation would be based only on the room with the heater.

$$\frac{\text{BTU/Hr} = (15\frac{1}{2}) \times (12) \times (8)}{50} \times 1000 = 29760 \text{ BTU/Hr}$$

**WARNING**

If the area in which the heater may be operated is smaller than that defined as an unconfined space or if the building is of unusually tight construction, provide adequate combustion and ventilation air by one of the methods described in the National Fuel Gas Code, ANSI Z223.1/NFPA 54, Section 5.3 or applicable local codes.

## FIREPLACE AND HEARTH DIMENSIONS

### WARNING

This appliance is for installation only in a solid-fuel burning masonry or UL127 factory-built fireplace, vent free appliance, or in listed ventless firebox enclosure. It has been design certified for these installations.

**Exception:** DO NOT install this appliance in a factory-built fireplace that includes instructions stating it has not been tested or should not be used with unvented gas logs.

Use manufacturer's installation and clearance requirements as defined in their manual.

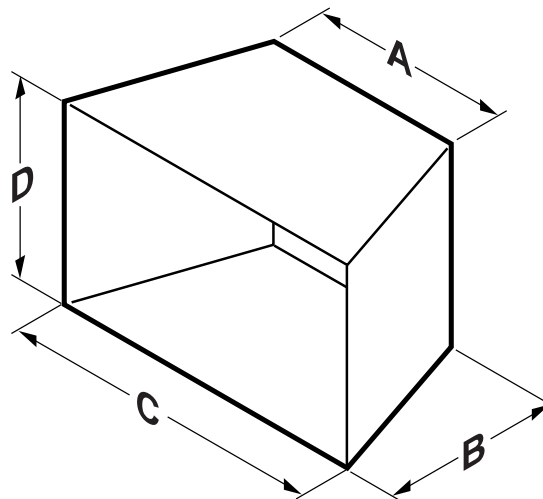
The HVFL Series unvented room heater is approved for installation into the following unvented fireplaces:

**GCUF Series Fireboxes Magnum36/42 or Lo-Rider36**

**NOTE:** HVFL24 log set will not fit into GCUF32 fireboxes.

The HVFL Series unvented room heater may also be installed into a Ventless Firebox Enclosure for Gas Fired Decorative Type Unvented Room Heaters per IAS Requirement No. 2-97 ANSI Z21.91-2001 (typically referred to as a "Universal Firebox"), as long as firebox hearth dimensions meet the minimum hearth dimensions shown below.

Model	A	B	C	D
HVFL18	18"	13 <sup>1</sup> / <sub>4</sub> "	27"	17"
HVFL24	22 <sup>1</sup> / <sub>4</sub> "	13 <sup>1</sup> / <sub>4</sub> "	28 <sup>1</sup> / <sub>2</sub> "	17"
HVFL24 with 30" Logs	25 <sup>1</sup> / <sub>2</sub> "	13 <sup>1</sup> / <sub>4</sub> "	32 <sup>1</sup> / <sub>2</sub> "	17"



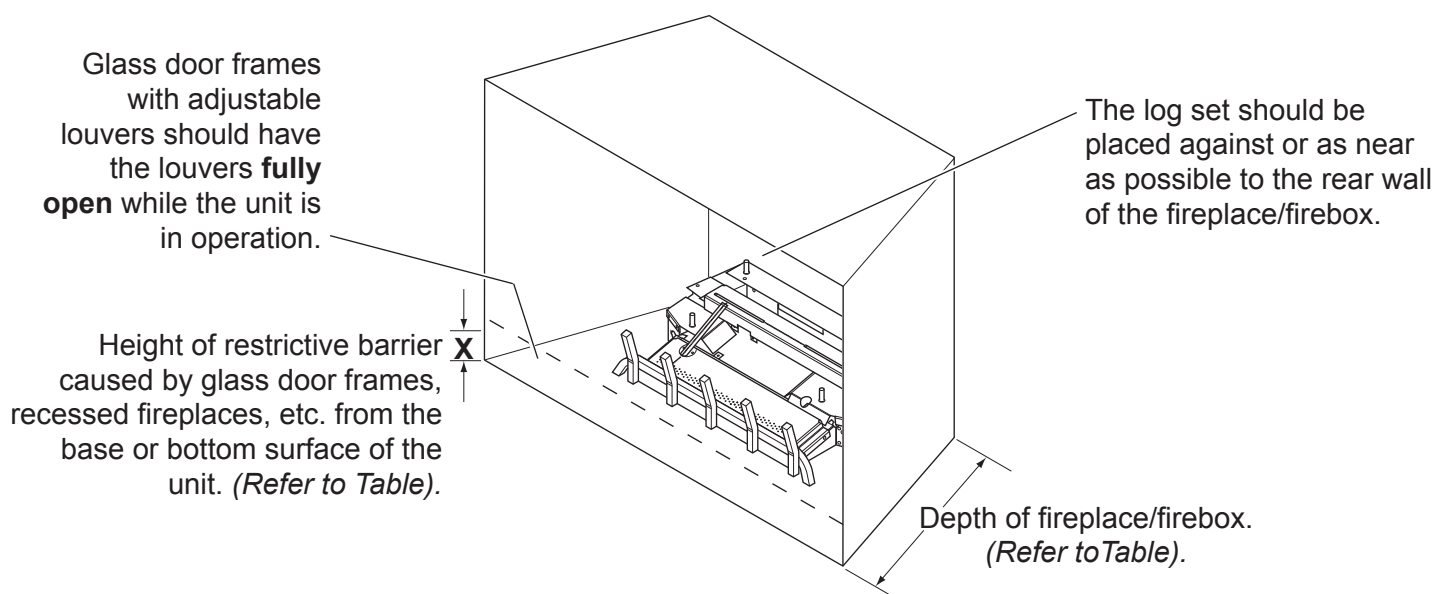
**Figure 2 - Hearth Minimum Dimension**

## PLACEMENT IN A FIREPLACE WITH A RESTRICTIVE BARRIER

### IMPORTANT INFORMATION FOR THE INSTALLATION OF THIS GAS LOG SET

The following are guidelines for placing a gas log set in a fireplace that has a restrictive barrier along the bottom front opening of the fireplace. Some examples of barriers are glass/screen door frames and sunken/recessed fireplaces.

Height of Restriction (X)	Minimum Depth of Fireplace/Firebox
No restriction	13 <sup>1</sup> / <sub>4</sub> "
0 to 1 <sup>1</sup> / <sub>2</sub> "	16"
From 1 <sup>1</sup> / <sub>2</sub> " to 3"	16"
Greater than 3"	ANY BARRIER GREATER THAN THREE INCHES (3") PLACED IN FRONT OF THE GAS LOG SET IS NOT RECOMMENDED BY THE MANUFACTURER.



**Figure 3 - Reference Drawing of a Natural Flame Log Set in an Enclosure**

**WARNING**

Barriers such as the bottom of a glass door frame placed in front of a gas log set can change the air flow characteristics of the fireplace which in turn can cause the unit to overheat and malfunction.

**NOTE:** Non combustible material such as refractory brick may be used to line the floor of the fireplace in order to raise the height of the gas log set in relation to a restrictive barrier. If the unit is raised, the minimum height dimension listed in the homeowner's manual must not be exceeded.

**NOTE:** If the log set is equipped with a remote receiver, a restrictive barrier may reduce the battery life by increasing the ambient temperature inside the fireplace. Placement of the receiver outside of the fireplace will extend the battery life.

## CLEARANCES AND HEIGHT REQUIREMENTS

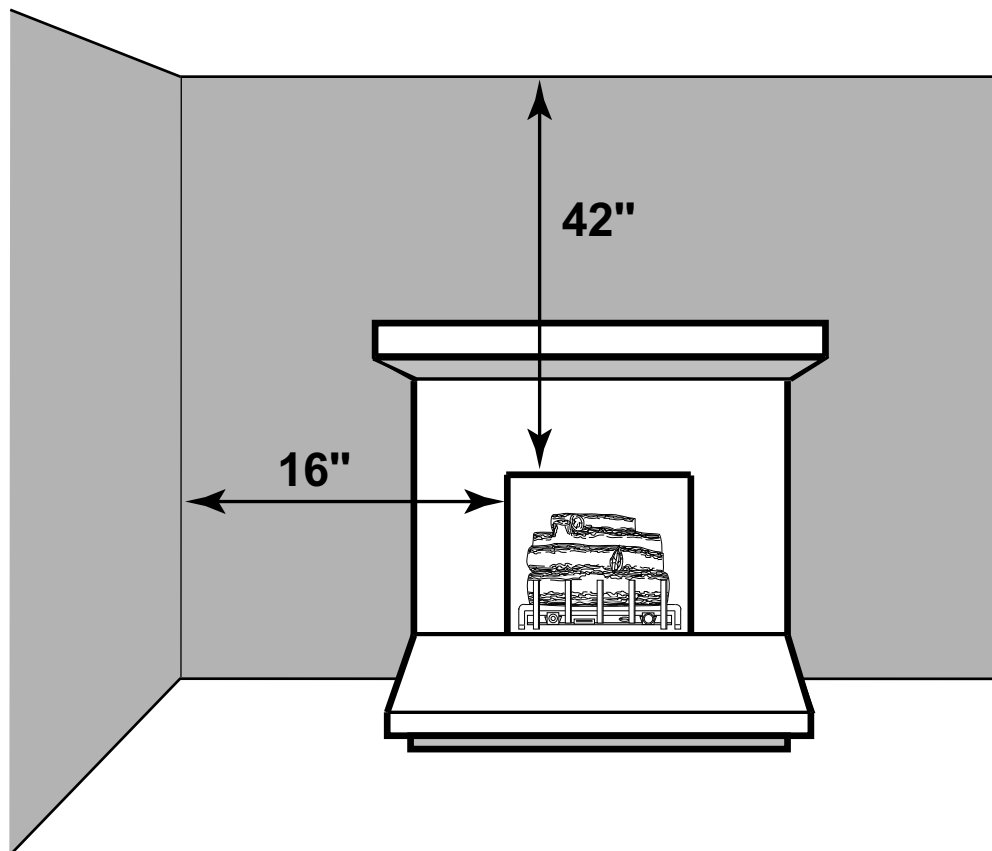
### WARNING

The dimensions shown in Figures 4 through 12 and defined in the fireplace manufacturer's instructions are *minimum clearances* to maintain when installing this heater. Left and right clearances are determined when facing the front of the heater.

When heater is installed into a ventless firebox, minimum clearances, as specified by the ventless firebox manufacturer, must be met.

*Follow these instructions carefully to ensure safe installation. Failure to follow instructions exactly can create a fire hazard.*

**Sidewall and ceiling clearances:** The *sides* of the fireplace opening must be *at least 16"* from any combustible wall. The *ceiling* must be *at least 42"* from the top of the fireplace opening.



*Figure 4 - Sidewall and Ceiling Clearances*

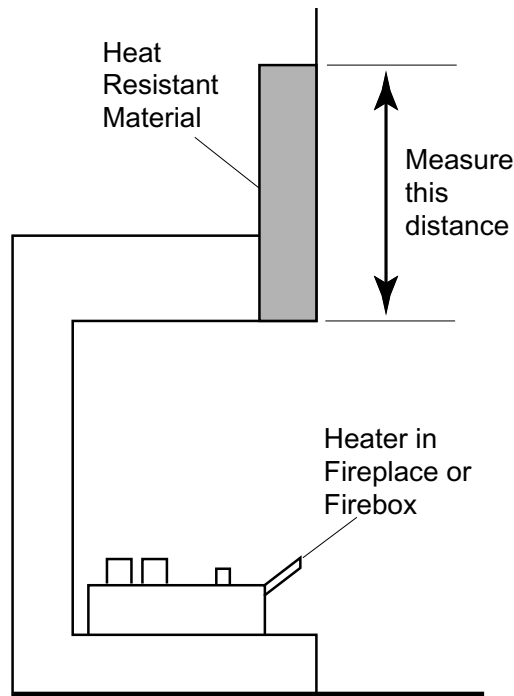
## CLEARANCES and HEIGHT REQUIREMENTS

### Heat resistant material (minimum requirements) with no wooden mantel or other combustible projection:

To install the gas logs into a fireplace with no wooden mantel, shelf or other combustible projection above the fireplace opening, measure the heat resistant material height, *per Figure 5, then see TABLE A.*

Heat resistant materials such as slate and marble must be at least 1/2" thick. Sheet metal should not be installed onto combustible material.

**IMPORTANT:** If you cannot meet these minimum clearances you must operate the heater with chimney flue damper open. Refer to "Installing Vented Applications" found on page 18.



**Figure 5 - Measuring Heat Resistant Material**

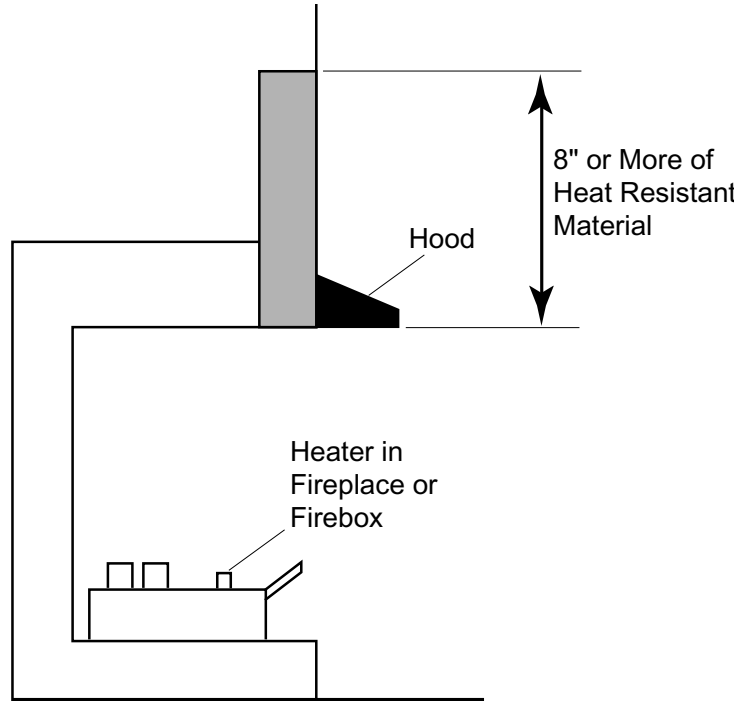
HEAT RESISTANT MATERIAL MEASUREMENT	REQUIREMENTS FOR SAFE INSTALLATION	
	HVFL18	HVFL24
12" or more	Hood not required.	Hood not required.
8" to less than 12"	Hood not required.	Extend heat resistant material to 12" or install hood. <i>See Figure 5.</i>
Less than 8"	Extend heat resistant material to at least 8" and install hood. <i>See Figure 5.</i>	Extend heat resistant material to at least 8" and install hood. <i>See Figure 5.</i> <b>OR</b> , extend heat resistant material to a height of at least 12".

**TABLE A - Heat Resistant Material Requirements with no Mantel or Combustible Projection**

## CLEARANCES and HEIGHT REQUIREMENTS

### Heat resistant material (minimum requirements) with wooden mantel or other combustible projection:

To install the heater with a wooden mantel, shelf or other combustible projection above, first measure the heat resistant material shown in *Figure 6*, then refer to Table B.

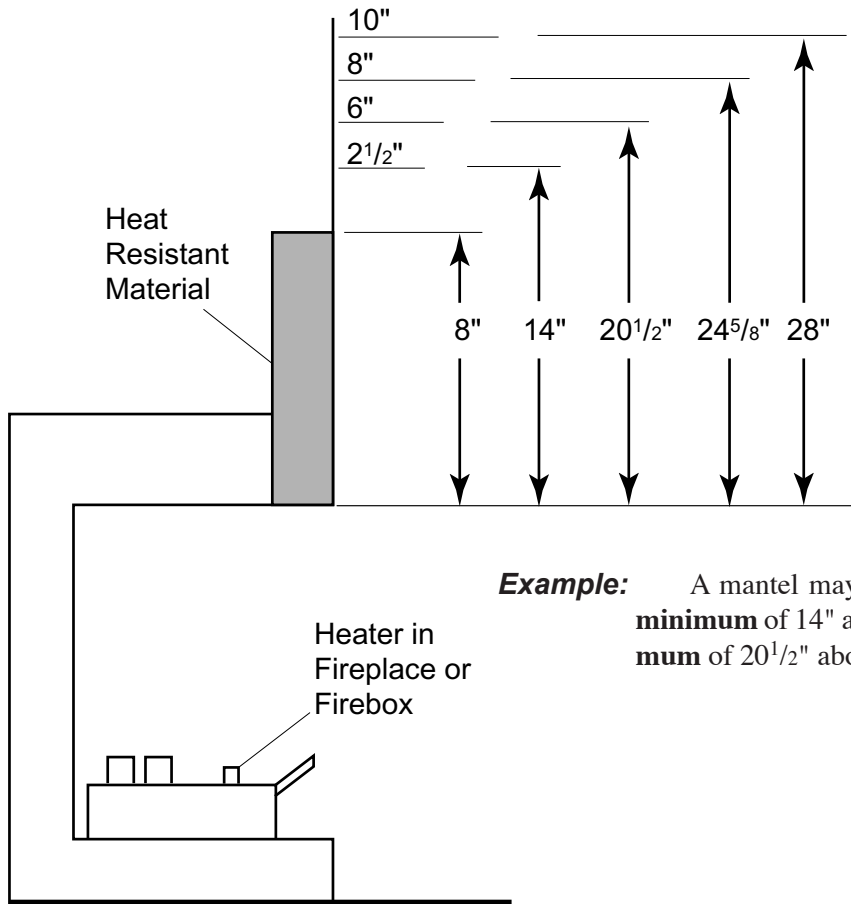


**Figure 6 - Measuring Heat Resistant Material for Mantel**

HEAT RESISTANT MATERIAL MEASUREMENT	REQUIREMENTS FOR SAFE INSTALLATION WITH WOODEN MANTEL, SHELF OR OTHER COMBUSTIBLE PROJECTION	
	HVFL18	HVFL24
12" or more	Hood not required. Observe profiles (side elevations) shown in <i>Figure 7, page 15</i> .	Hood not required. Observe profile (side elevations) shown in <i>Figure 9, page 16</i> .
8" to less than 12"	Install hood and observe profiles shown in <i>Figure 8, page 15</i> ; <b>OR</b> extend heat resistant material to at least 12" and observe profiles shown in <i>Figure 7, page 15</i> .	Install hood and observe profiles shown in <i>Figure 7, page 15</i> ; <b>OR</b> extend heat resistant material to at least 12" and observe profiles shown in <i>Figure 9, page 16</i> .
Less than 8"	Extend heat resistant material to at least 8", install hood and observe profiles shown in <i>Figure 8, page 15</i> ; <b>OR</b> extend heat resistant material to at least 12" and observe profiles shown in <i>Figure 8, page 15</i> .	Extend heat resistant material to at least 8", install hood and observe profiles shown in <i>Figure 7, page 15</i> ; <b>OR</b> extend heat resistant material to at least 12" and observe profiles shown in <i>Figure 9, page 16</i> .

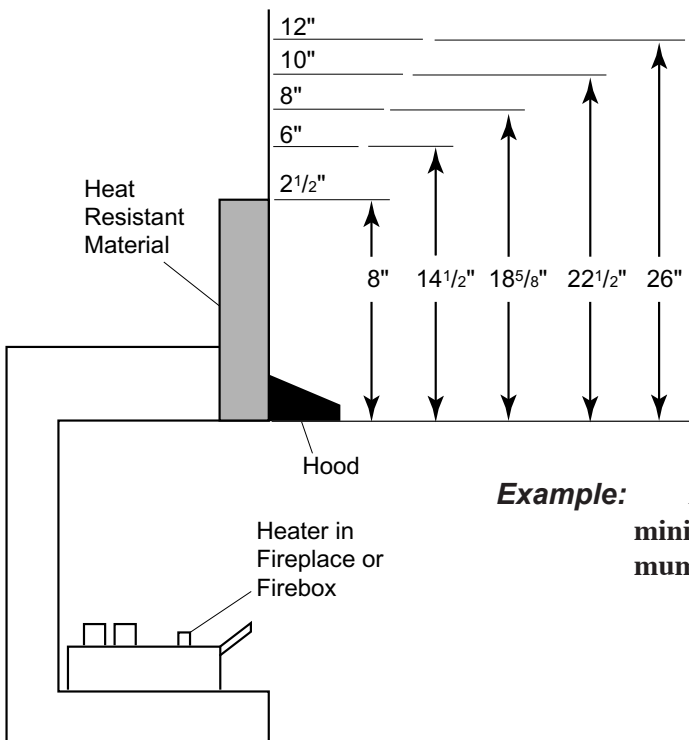
**TABLE B - Heat Resistant Material Heights and Mantel Location**

# CLEARANCES AND HEIGHT REQUIREMENTS



**Example:** A mantel may project from the wall a **maximum** of 2<sup>1</sup>/<sub>2</sub>" at a **minimum** of 14" above the opening, and a maximum of 6" at a **minimum** of 20<sup>1</sup>/<sub>2</sub>" above the opening.

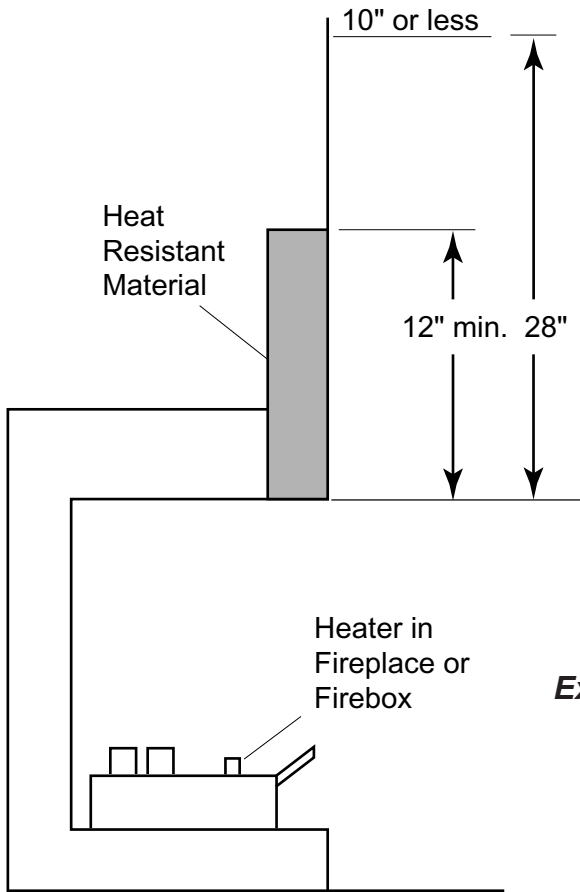
**Figure 7 - Minimum Mantel Clearance with No Hood - HVFL18**



**Example:** A mantel may project from the wall a **maximum** of 2<sup>1</sup>/<sub>2</sub>" at a **minimum** of 8" above the opening, and a maximum of 6" at a **minimum** of 14<sup>1</sup>/<sub>2</sub>" above the opening.

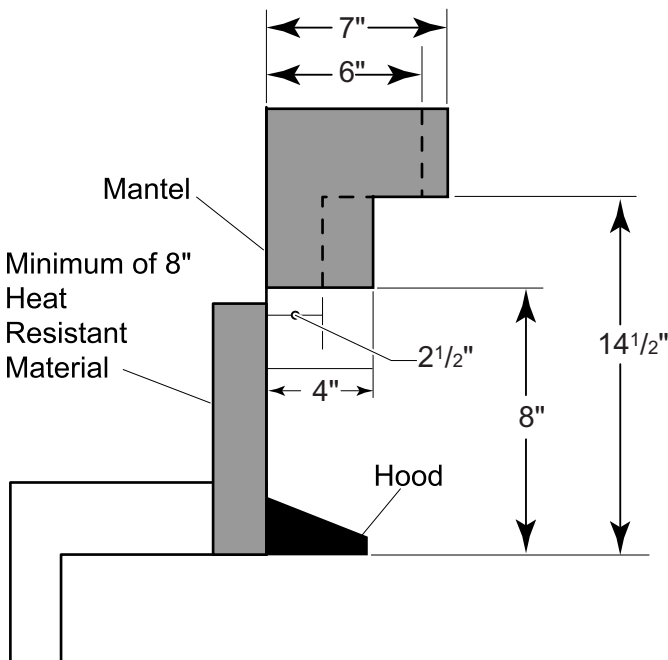
**Figure 8 - Minimum Mantel Clearance with Hood - All Models**

# CLEARANCES AND HEIGHT REQUIREMENTS



**Example:** The bottom of the mantel may project from the wall a maximum of 10" at a minimum of 28" above the

**Figure 9 - Minimum Mantel Clearance with No Hood — HVFL24**



**Figure 10 is an example of an unsafe mantel installation.** This mantel projects 4" at 8" above the opening, exceeding the maximum acceptable distance of 2<sup>1</sup>/<sub>2</sub>". The mantel also projects 7" at 14<sup>1</sup>/<sub>2</sub>" above the opening, exceeding the maximum acceptable distance of 6".

If your mantel profile is unsafe, you may either:

- Raise the mantel to an acceptable height
- OR**
- Remove the mantel

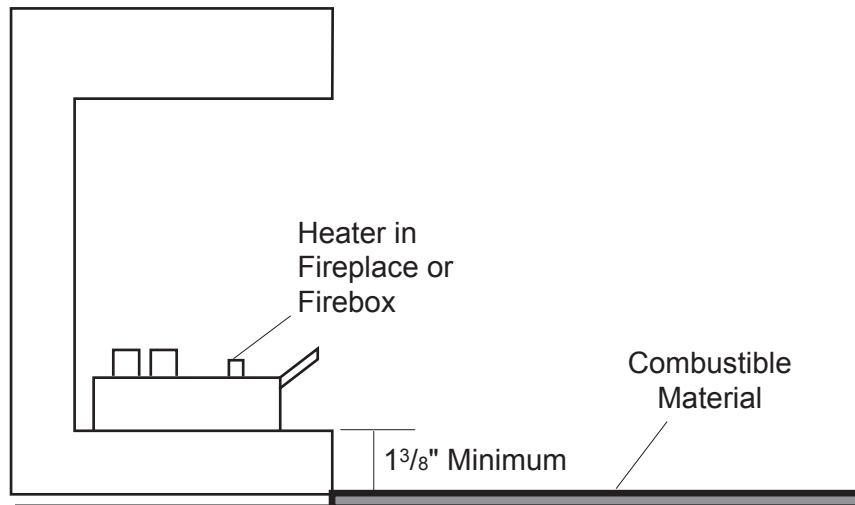
**Figure 10 - Minimum Mantel Clearance with No Hood - HVFL24  
(Example of Unsafe Installation)**



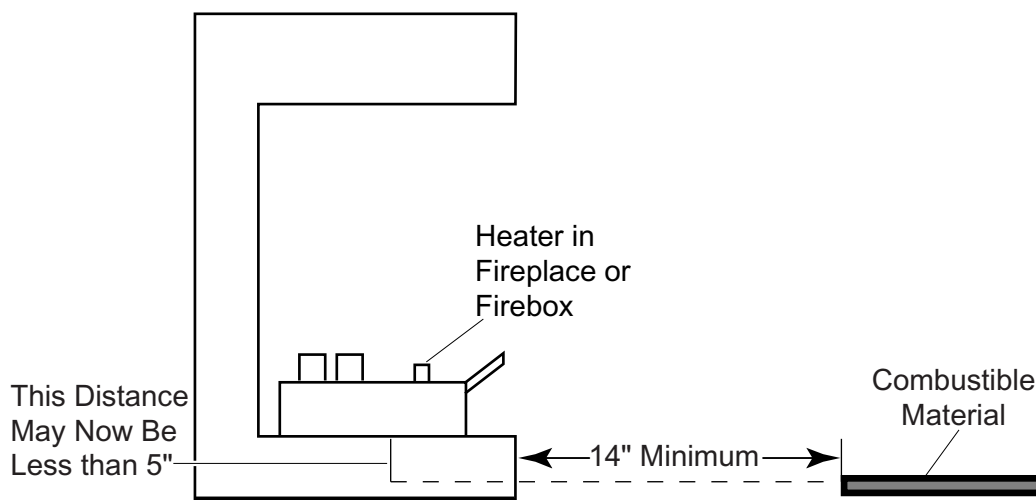
The gas log heater must be installed at least 5" above any combustible flooring material, such as carpeting or tile, which is closer than 14" to the base of the fireplace. The minimum distance must be maintained from the top surface of carpeting, tile, etc. *See Figure 11.*

**OR,**

The gas log heater may be installed nearer to the floor if a minimum of 14" of noncombustible material such as slate or marble is installed between the base of the fireplace and the combustible flooring. *See Figure 12.*



**Figure 11 - Minimum Clearance above Combustible Flooring**



**Figure 12 - Minimum Clearance above Combustible Flooring with Noncombustible Material Installed at Base of Fireplace**

## FIREPLACE PREPARATION

### BEFORE FULLY INSTALLING THE UNIT:

- Turn **OFF** the gas supply to the fireplace or firebox.
- Seal any fresh air vents and/or ash clean-out doors located on the floor or wall of the fireplace. If left unsealed, drafting may cause pilot outage or sooting. Use a heat resistant sealant. **Do not seal the chimney flue damper.**

### WARNING

Before installing in a solid fuel burning fireplace, The chimney flue and firebox must be cleaned of soot, creosote, ashes and loose paint by a qualified chimney cleaner.

### INSTALLING VENTED APPLICATIONS

Manual and milli-volt controlled gas logs may be installed as a vented decorative log set in compliance with ANSI Z21.60 and National Fuel Gas Code, Section 6.6. **Since, the gas logs are operated with the damper open, non-combustible material and minimum mantel requirements do not apply.**

### WARNING

This appliance is for installation only in a solid fuel burning fireplace (masonry fireplace or manufactured fireplace) with a working flue and constructed of noncombustible material.

**Exception:** DO NOT install this appliance in a factory-built fireplace that includes instructions stating that it has not been tested or should not be used with unvented gas logs. This log set may be installed as a vented log set.

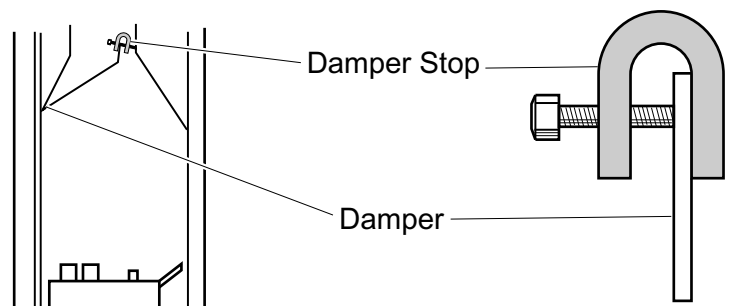
### BEFORE INSTALLING THE APPLIANCE:

- Turn off gas supply to fireplace or firebox.
- Have the fireplace floor and chimney professionally cleaned to remove ashes, soot, creosote or other obstructions. Have this cleaning performed annually after installation.
- Seal any fresh air vents or ash clean-out doors located on floor or wall of fireplace. If not, drafting may cause pilot outage or sooting. Use a heat-resistant sealant.

Install and operate the appliance as directed in this manual.

### DAMPER STOP INSTALLATION:

A damper stop must be provided with the unit. Contact your dealer to obtain one. The damper stop must be installed as shown in *Figure 13* to prevent full closure of the fireplace damper blade and provide a minimum 29 square inch flue opening.



**Figure 13 - Damper Stop Installation.**  
(See **WARNING** at top of next page.)

## WARNING

The fireplace and gas logs function as a system. If the fireplace is spilling into the room (check with a match or a smoke stick), reposition the damper clamp until a positive draft is obtained by opening the damper. If negative pressure in home prevents having a positive draft, contact your dealer for assistance.

## PLACING AND SECURING APPLIANCE

## WARNING

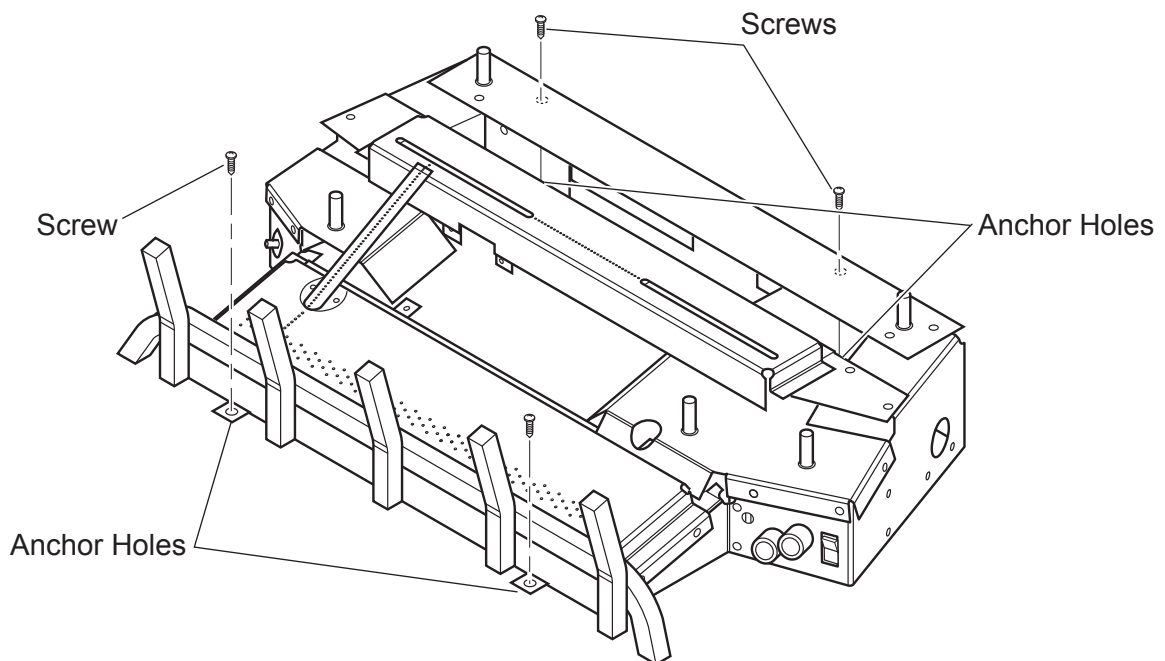
You must secure the gas log heater to the fireplace floor. If not, the entire unit may move when you adjust the controls. Movement of unit may cause shifting of the gas logs which leads to sooting and improper burning. Grate movement could cause a gas leak.

Special care is required if you are installing the unit into a sunken fireplace. You must raise the fireplace floor to allow access to gas log controls. This will insure adequate air flow and guard against sooting. Raise the fireplace floor using noncombustible materials, as described in *Placement in a Fireplace with Restrictive Barrier* on page 11.

## ASSEMBLY PROCEDURE:

1. Center the gas log unit in the fireplace or firebox. Make certain the front feet of the grate sit inside the front edge of the fireplace or firebox.
2. Anchor holes are located in front of the unit and in the back (right and left sides) of the unit. After centering the grate correctly, mark the hole positions on the fireplace/firebox floor. Drill two (2)  $\frac{5}{32}$ " diameter holes approximately  $1\frac{1}{2}$ " deep.
3. Anchor the grate to the fireplace/firebox floor using the screws provided. *See Figure 14.*

Proper installation of the grate is essential to prevent any movement of the gas logs and controls during operation.



**Figure 14 - Securing Heater to Floor of Fireplace/Firebox**

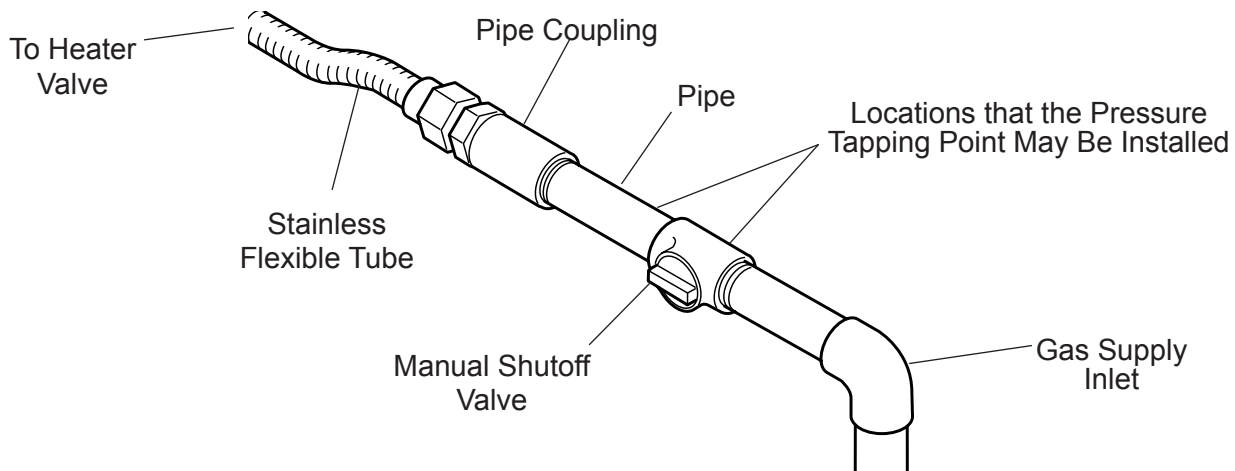
## CONNECTING THE GAS

**NOTICE:** A qualified gas appliance installer must connect the heater to the gas supply. Consult all local codes.

**CAUTION**

Use new black iron or steel pipe. Internally tinned copper or copper tubing can be used per National Fuel Code, section 2.6.3, providing gas meets hydrogen sulfide limits, and where permitted by local codes. Gas piping system must be sized to provide minimum inlet pressure (Listed on Data Plate) at the maximum flow rate (BTU/Hr). Undue pressure loss will occur if the pipe is too small.

A manual shutoff valve must be installed upstream of the appliance. Union tee and plugged  $\frac{1}{8}$ " NPT pressure tapping point should be installed upstream of the appliance. See Figure 15.



**Figure 15 - Gas Connection**

**IMPORTANT:** Hold heater valve firmly with a wrench to prevent movement when connecting to inlet pipe.

**CAUTION**

**CHECK GAS TYPE:** The gas supply must be the same as stated on the heater's rating plate. If the gas supply is different, **DO NOT INSTALL THE HEATER.** Contact your dealer for the correct model.

Always use an external regulator for all propane/LPG heaters and high pressure one to two-pound systems only, to reduce the supply tank pressure to a maximum of 13" w.c. This is in addition to the internal regulator in the heater valve.

### WARNING

**Connecting directly to an unregulated propane/LPG tank can cause an explosion.**

The heater gas inlet connection is a  $\frac{3}{8}$ " NPT at the valve. On all control type units, the inlet connection is on the right side of unit. To connect from the opposite side, route the pipe around the back portion of the unit.

When tightening up the joint to the valve, hold the valve securely to prevent movement.

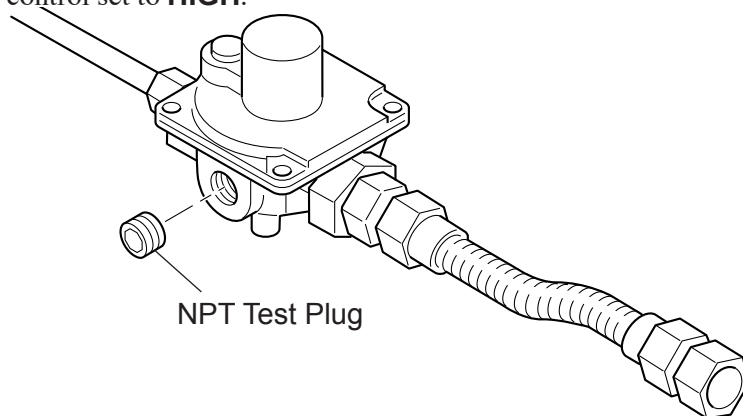
Test all gas joints from the gas meter to the heater valve for leaks using a gas analyzer or soap and water solution after completing connection. **DO NOT USE AN OPEN FLAME.**

Check the gas pressure with the appliance burning and the control set to **HIGH**.

### MANUAL CONTROL (Figure 16)

**The pressure regulator is preset and locked to discourage tampering.** If the pressure is not as specified, replace the regulator with the correct part from the parts list in this manual.

Remove  $\frac{1}{8}$ " NPT plug, located on side of regulator body. Install fitting and tubing to pressure gauge. After taking pressure reading, reinstall test plug. Check for gas leaks.

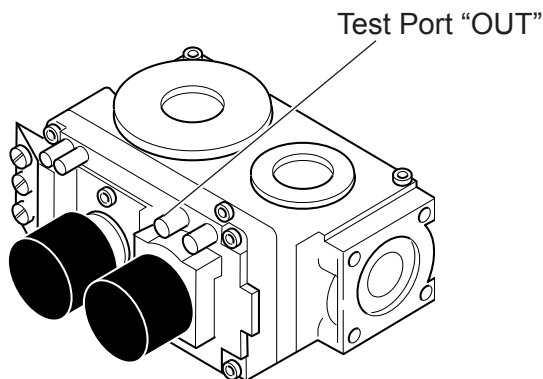


**Figure 16 - Pressure Test Point Location  
Manual Control**

### MILLI-VOLT CONTROL (Figure 17)

The valve regulator controls the burner pressure which should be checked at the pressure test point.

Turn captured screw counter clockwise two or three turns and then place tubing to pressure gauge over test point (Use test point "OUT" closest to control knob). After taking pressure reading, be sure and turn captured screw clockwise firmly to re-seal. Do not over torque. Check for gas leaks.



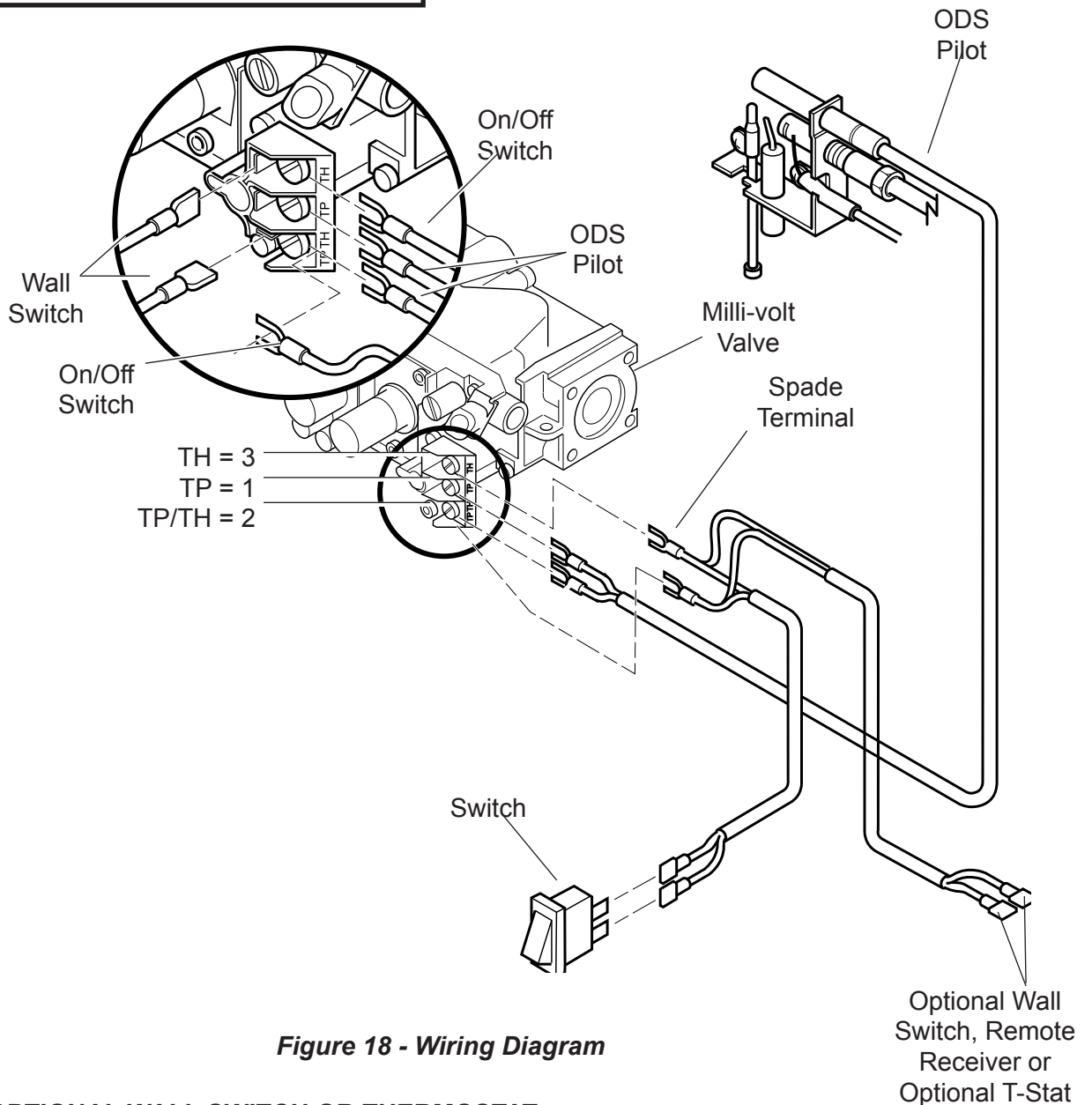
**Figure 17 - Pressure Test Point Location  
Milli-Volt Control**

## ELECTRICAL WIRING (MILLI-VOLT)

The milli-volt valve is a self-powered combination gas control **THAT DOES NOT REQUIRE 110 VAC TO OPERATE.**

**CAUTION**

Label all wires prior to disconnection when servicing controls. Wiring errors can cause improper and dangerous operation. Verify proper operation after servicing.



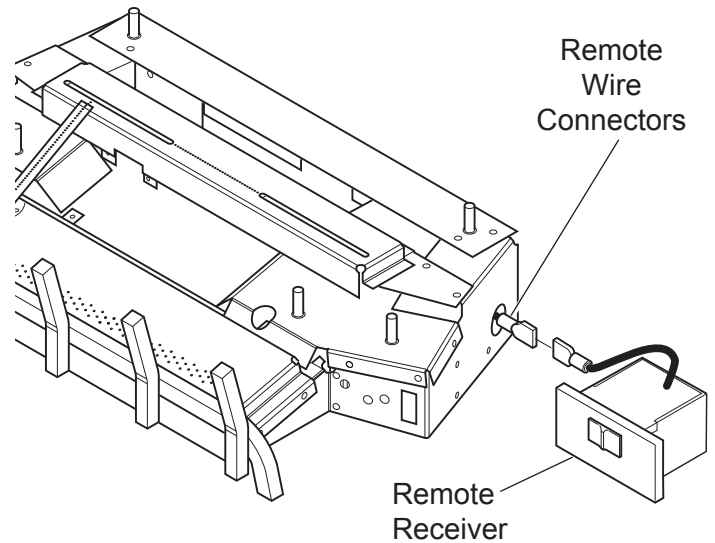
**Figure 18 - Wiring Diagram**

### CONNECTING OPTIONAL WALL SWITCH OR THERMOSTAT

1. Use 18 awg, two-wire cable, 15 feet maximum length.
2. At one end of the cable, connect both wires to the wall switch or thermostat. At the other end, connect one wire to TP/TH and one wire to TH, or connect the wall switch/thermostat to the two male (0.25") terminals on the left side of the unit. The color of the wires does not matter.

## CONNECTING REMOTE RECEIVER

THESE INSTRUCTIONS SUPERCEDE THE SECTION ENTITLED "HEARTH MOUNT" IN THE MILLI-VOLT HAND-HELD REMOTE INSTRUCTIONS SUPPLIED WITH THE REMOTE.



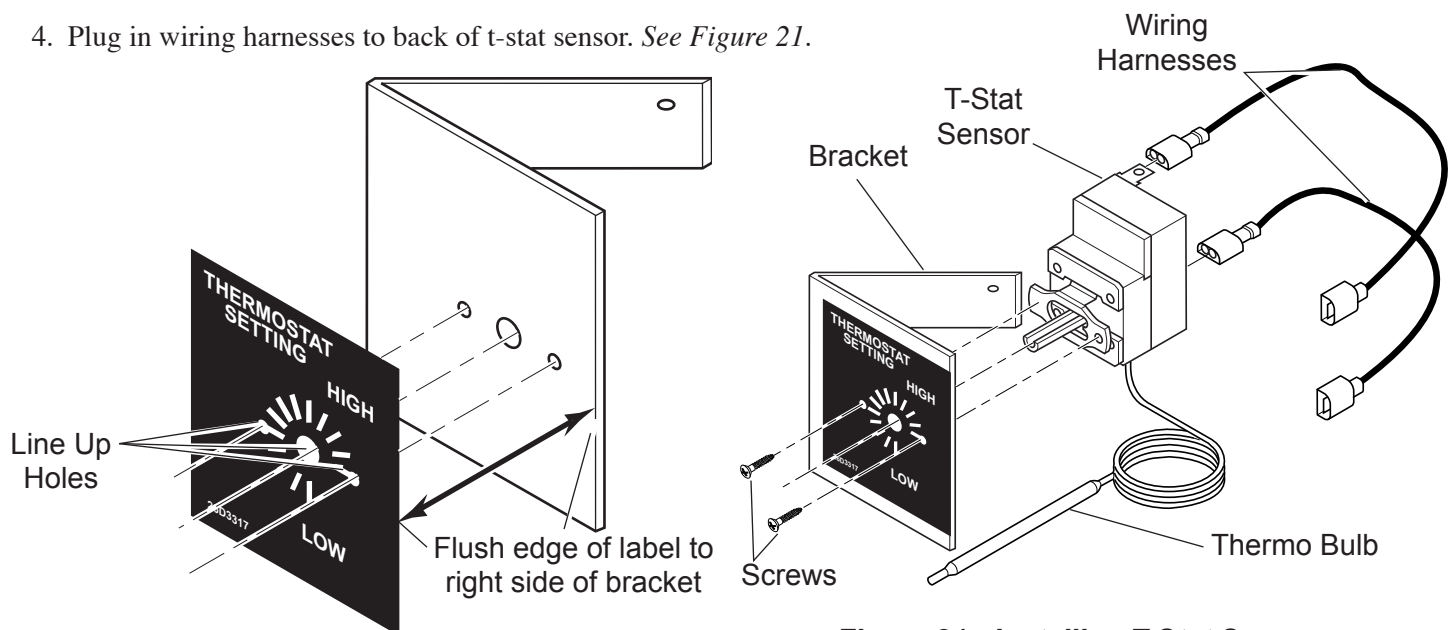
**Figure 19 - Installing Remote Receiver**

1. Cut cable to length (approximately 12") for placement in the fireplace.
2. Strip back 1/4" of the insulation from both ends of each wire.
3. Connect two .25 female connectors to the wires at one end of the cable.
4. Insert the opposite end into receiver (special fitting on Ambient remotes).
5. Connect the connectors to the two .25" male connectors located on the right side when facing the unit (*Figure 19*). Do not let the wire touch the grate or burners.
6. Stick velcro pads with self-adhesive backing to side of remote receiver and to the right side of the unit. See *Figure 19*.
7. Attach remote receiver with velcro pads. Control switch must face forward.

**NOTE: Heat reduces battery life. You can protect the receiver and extend battery life by mounting the receiver in a wall or other location outside the fireplace.**

## INSTALLING T-STAT SENSOR (OPTION SOLD SEPARATELY)

1. Remove metal bracket and label from box.
2. Peel away the paper backing on the label. Line up holes in label with holes on the bracket. Right side of label should flush with right side of bracket. See *Figure 20*. Press label firmly and smoothly to bracket.
3. Using Phillips screwdriver, install t-stat sensor to bracket with two screws provided. See *Figure 21*. Make sure the thermo bulb wire is at the bottom of t-stat sensor.
4. Plug in wiring harnesses to back of t-stat sensor. See *Figure 21*.

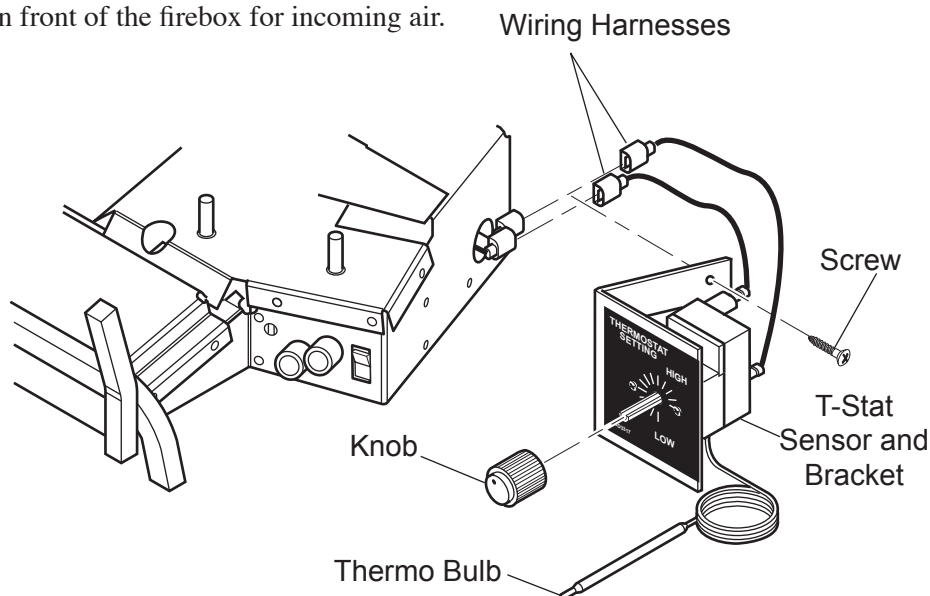


**Figure 20 - Applying Label to Bracket**

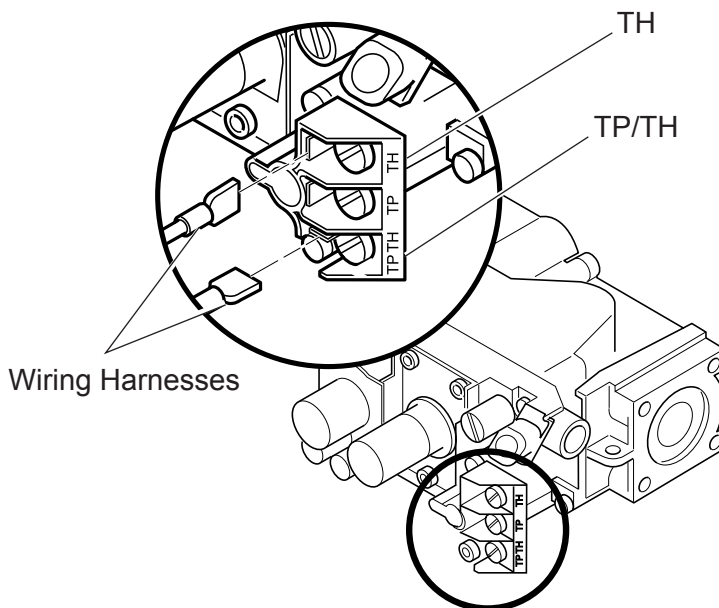
**Figure 21 - Installing T-Stat Sensors and Wiring Harnesses**

## ELECTRICAL WIRING (MILLI-VOLT)

5. Route wiring harnesses through large hole on side of unit. Mount bracket to side of unit with screw provided. *See Figure 22.*
6. Attach wiring harness to either TP/TH and TH on control valve or to existing wiring harness with two (2) 0.250" male spade terminals for remote or t-stat option. *See Figures 22 and 23.*
7. Install knob to shaft of t-stat sensor. *See Figure 22.*
8. Place thermo bulb in front of the firebox for incoming air.



**Figure 22 - Installing T-Stat Sensor to HVFL Base with Screw Provided**

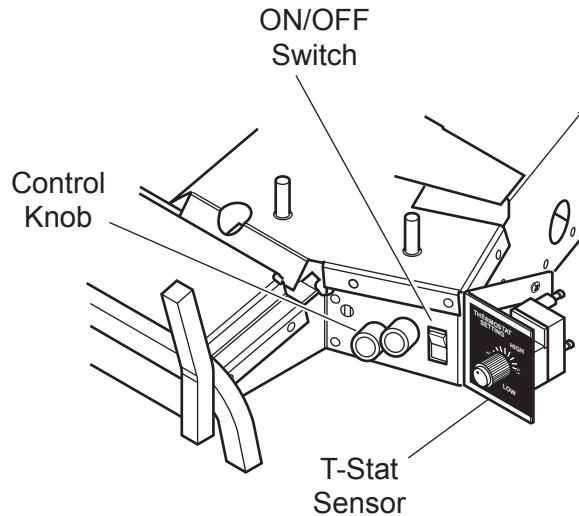


**Figure 23 - Attaching Wiring Harnesses to Control Valve**



## OPERATION OF THERMOSTAT SENSOR

1. Follow millivolt lighting instructions on lighting plate attached to unit or in homeowner's manual.
2. With control knob in the "ON" position make sure the ON/OFF switch is in the "OFF" position. *See Figure 24.*
3. The unit is now being controlled by the thermostat sensor. The sensor will now cycle the burners on and off. You can adjust how often the unit cycles by turning the control knob on the sensor.



**Figure 24 - Control Knob in "ON" Position and ON/OFF Switch in "OFF" Position**

## CHECKING SYSTEM OPERATION

The milli-volt system and individual components may be checked with a milli-volt meter having a 0-1000 mV range. Conduct each check shown in chart below by connection meter test leads to terminals as indicated.

CHECK TEST	TO TEST	CONNECT METER LEADS TO TERMINALS	THERMOSTAT CONTACTS	METER READING SHOULD BE
A	COMPLETE SYSTEM	2 & 3	CLOSED	MINIMUM 175
B	THERMOPILE OUTPUT	1 & 2	OPEN	MINIMUM 500

### A. COMPLETE MILLI-VOLT SYSTEM CHECK

**("A" Reading - Thermostat contacts CLOSED - Control Knob "ON" - Main burner should turn ON)**

- a. If the reading is more than 175 milli-volts and the automatic valve still does not come on, replace the control.
- b. If the closed circuit reading ("A" reading) is less than 175 milli-volts, determine cause for low reading, proceed to Section B below.

### B. Thermopile Output Reading Check

**("B" Reading - Thermostat contacts OPEN - Main burner OFF)**

1. Check gas pressure to the unit. If gas pressure is within minimum and maximum on data plate, then check pilot voltage, 500 milli-volts minimum. If the minimum milli-volt reading is not obtainable, replace pilot.

## ROCK WOOL AND LOG PLACEMENT

**Before you begin** — This unit is supplied with four or five ceramic fiber logs. Do not handle these logs with your bare hands. **Always wear gloves to prevent skin irritation from ceramic fibers.** After handling the logs, wash your hands gently with soap and water to remove any traces of fibers.

**WARNING**

The positioning of the logs are critical to the safe and clean operation of this heater. Sooting and other problems may result if the logs are not properly and firmly positioned in the appliance. **Never add additional logs or embellishments such as pine cones, vermiculite or rock wool to the heater. Only use the logs and EB-RW (rock wool) supplied with the unit.**

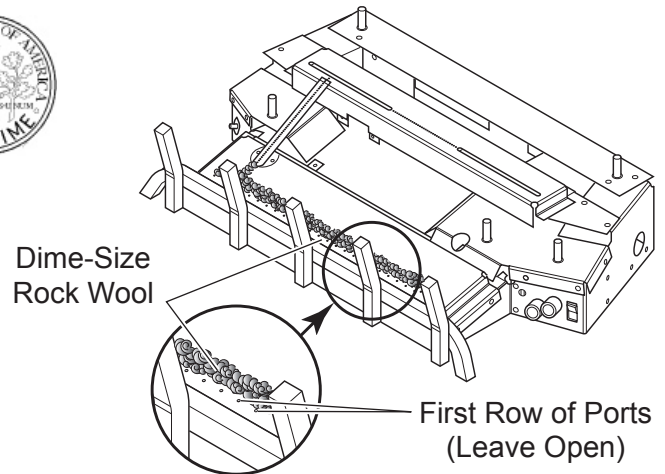
**Failure to position the parts in accordance with diagrams below or to use only parts specifically approved for this heater may result in property damage or personal injury.**

### PLACING ROCK WOOL

Starting on the second row of burner ports, place EB-RW (Rock Wool) in dime-size pieces on the second row of ports and going toward back of front burner.



**NOTE: Do not put EB-RW (Rock Wool) on first row of burner ports.**



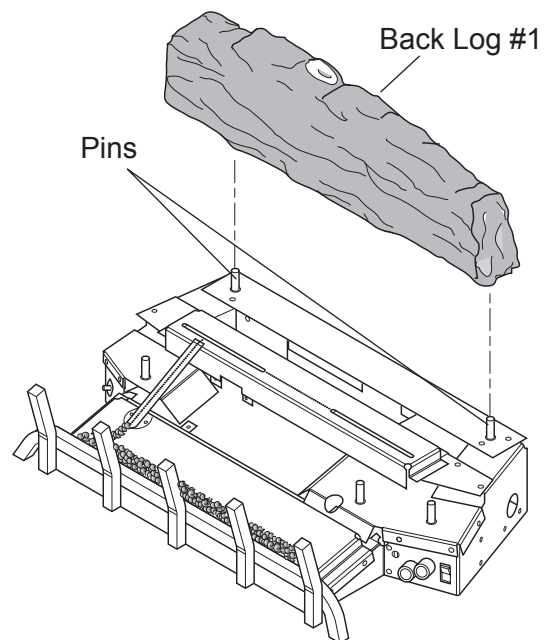
**Figure 25 - Placing Rock Wool**

**WARNING**

- Use only EB-RW provided with log set.
- Do not add additional rock wool.
- Place EB-RW (rock wool) on front burner ports only. **DO NOT PLACE EB-RW ON BACK BURNER!**

### INSTALLING KENTUCKY STACK LOGS ON GRATE

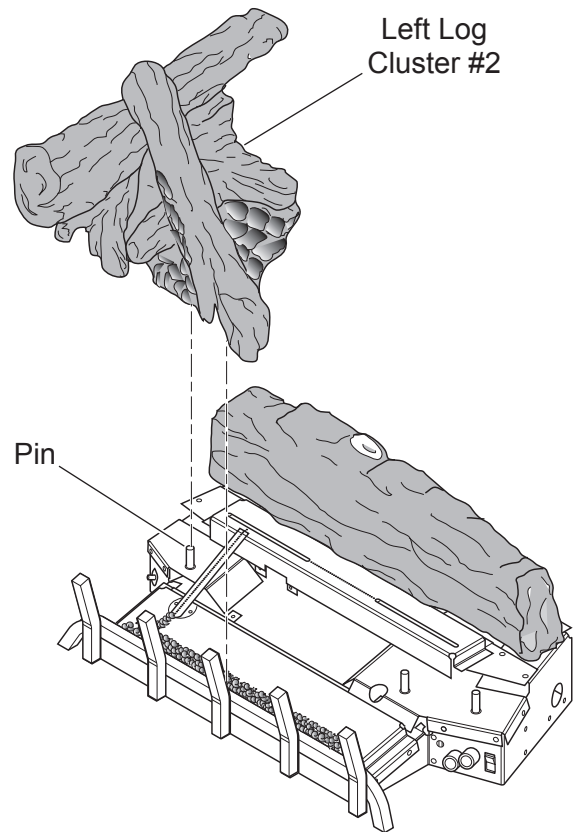
1. Install back log (#1) on two pins located near the back of base. Check log position and stability. *See Figure 26.*



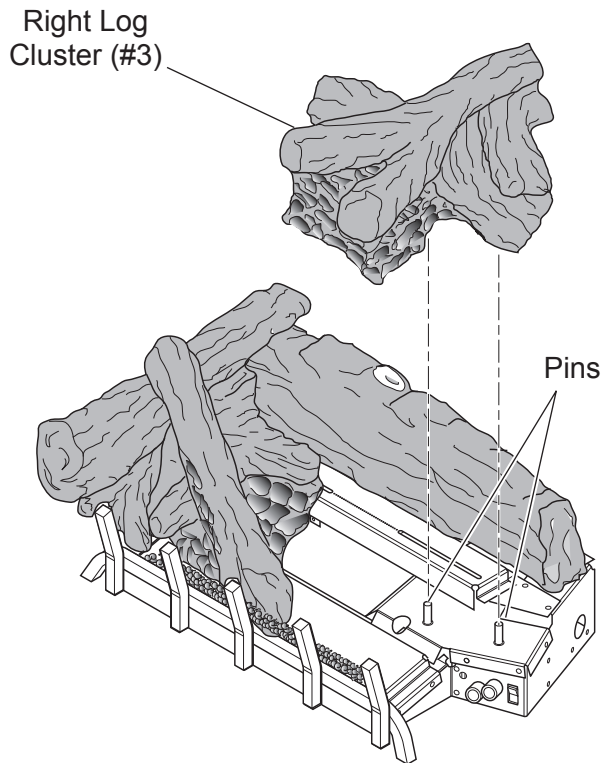
**Figure 26 - Installing Back Log**

## LOG PLACEMENT

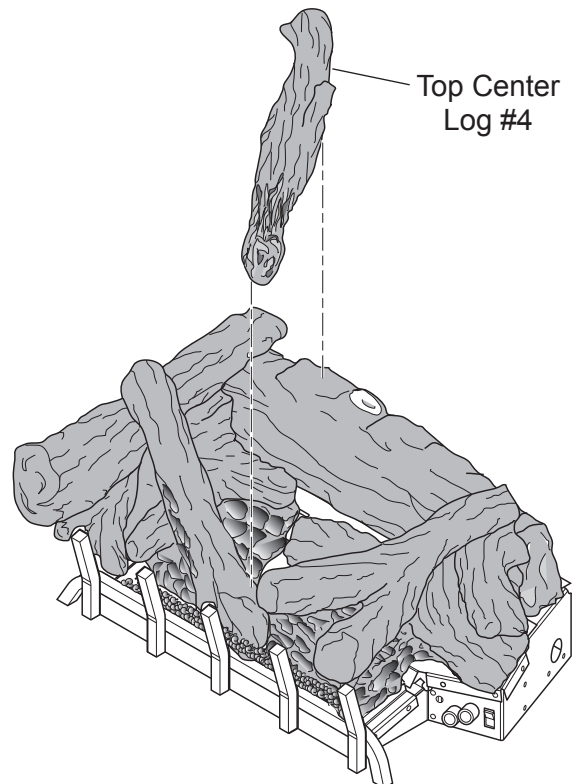
2. Install left log cluster (#2) on pin located near left edge of base. *See Figure 27.*
3. Install right log cluster (#3) on two pins located on right side of base. *See Figure 28.*
4. Rest end of top center log (#4) on rear log. Place front end of top center log where right and left cluster logs meet. *See Figure 29.*



**Figure 27 - Installing Left Log Cluster (#2)**



**Figure 28 - Installing Right Log Cluster (#3)**

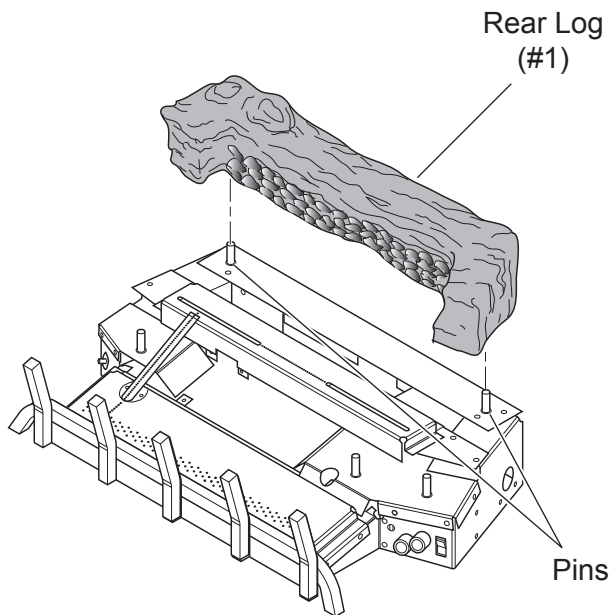


**Figure 29 - Installing Top Center Log (#4)**

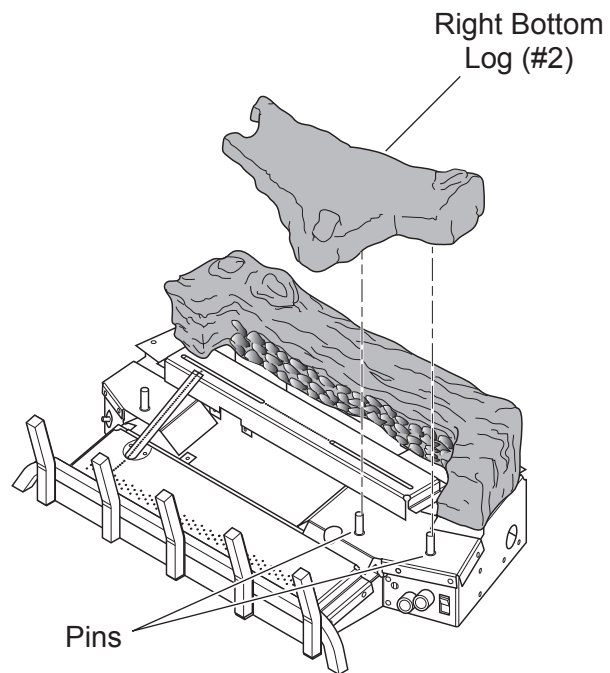
# LOG PLACEMENT

## INSTALLING SPLIT MAPLE LOGS ON GRATE

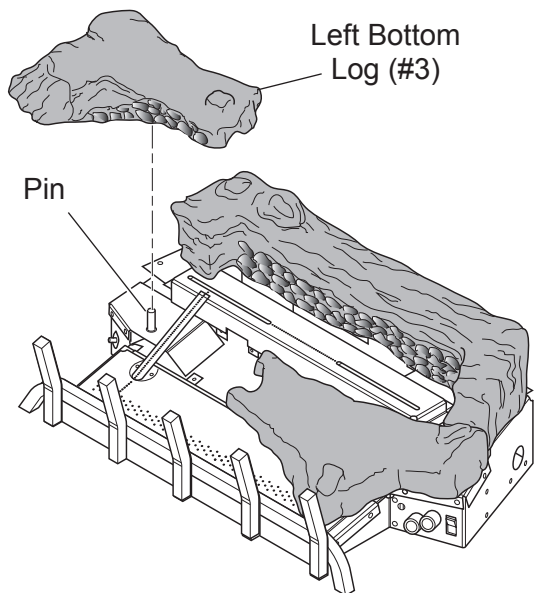
1. Install back log (#1) on two pins (2) located near the back of base. Check log position and stability. *See Figure 30.*
2. Install right bottom log (#2) on two (2) pins located on right side of base. *See Figure 31.*
3. Install left bottom log (#3) on pin located on right side of base. *See Figure 32.*
4. Lay back end of center top log (#4) on the center of back log. Position front end of center top log (#6) on protrusion of bottom left log. *See Figure 33.*



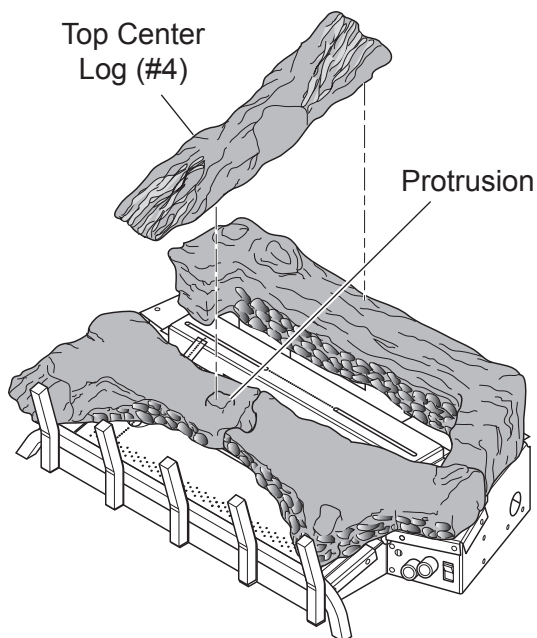
**Figure 30 - Installing Back Log (#1)**



**Figure 31 - Installing Right Bottom Log (#2)**

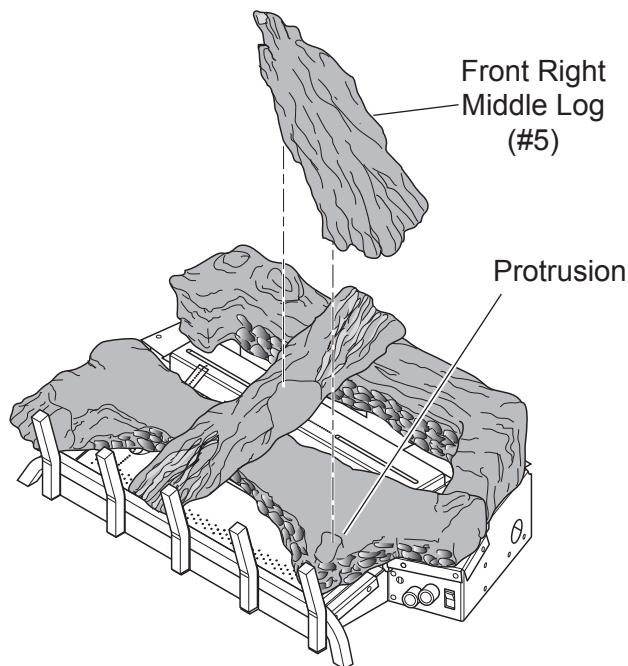


**Figure 32 - Installing Left Bottom Log (#3)**

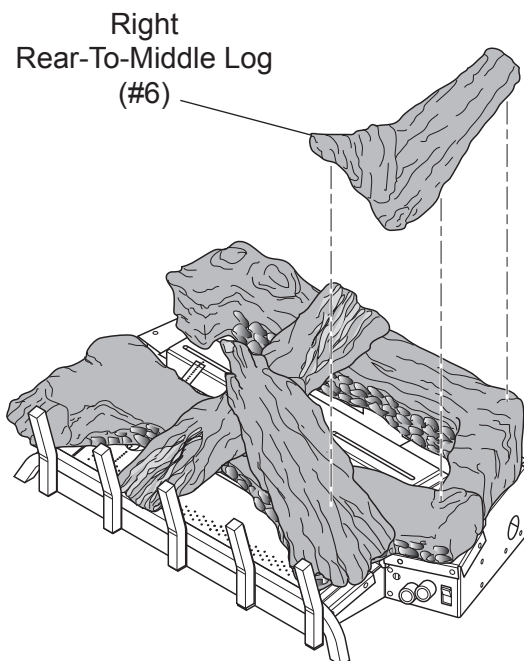


**Figure 33 - Installing Center Top Log (#4)**

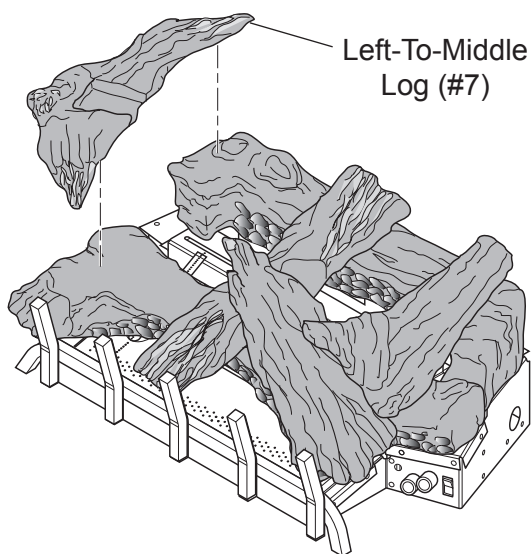
5. Place front right middle log (#5) on protrusion of bottom right log. *See Figure 34.*
6. Position back end right rear-to-middle log (#6) on back log. Rest front end of right rear-to-middle log (#6) on front right middle log. *See Figure 35.*
7. Install left-to-middle log (#7) on left end of back log and left bottom log. *See Figure 36.*
8. Lay back end of left front log (#8) in recessed area of middle of center top log. *See Figure 37.*



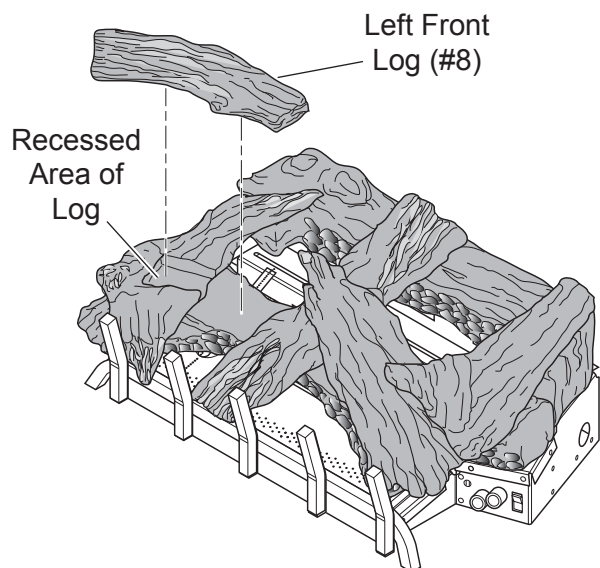
**Figure 34 - Installing Top Right Log (#5)**



**Figure 35 - Installing Right Rear-To-Middle Log (#6)**



**Figure 36 - Installing Right Left-To-Middle Log (#7)**



**Figure 37 - Installing Left Front Log (#8)**

# FLAME APPEARANCE

## PLACING THE DECORATIVE ROCK

**CAUTION**

**DO NOT** sprinkle volcanic rock on the logs, around the pilot, or on or near burners. This may cause sooting. Place volcanic rock only on the floor of the fireplace.

During initial operation of the new heater, burning logs will give off a paper burning smell and orange flames will be present. Simply open the windows for a few hours to vent the odor.

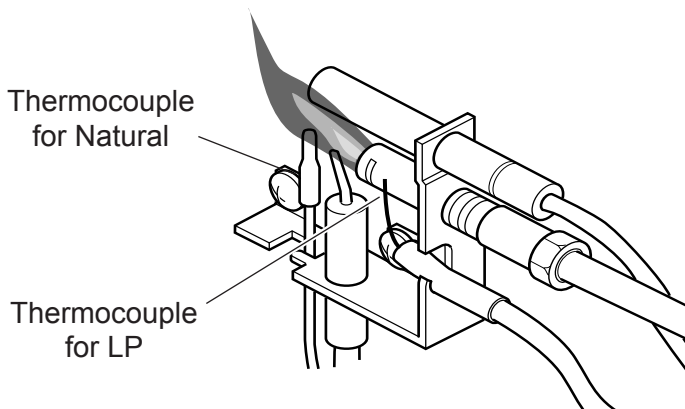
Flames from the pilot, front and rear burner should be visually checked as soon as the heater is installed. In addition, periodically check the flames visually during operation.

## CHECKING THE PILOT FLAME

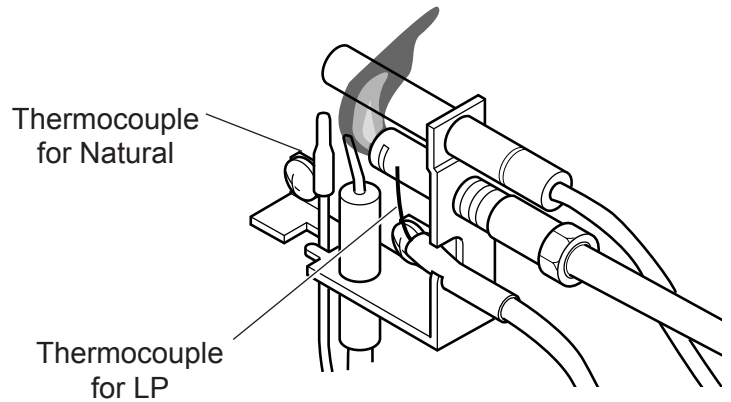
The pilot flame must always be present when the heater is in operation. It should just touch the top of the thermocouple tip for natural. See Figures 38 and 40 for correct pilot flame.

If the pilot flame does not touch the thermocouple, then the main burner cannot function reliably. See Figures 39 and 41 for incorrect shape of pilot flame.

## MILLI-VOLT CONTROL AND THERMOSTAT CONTROL

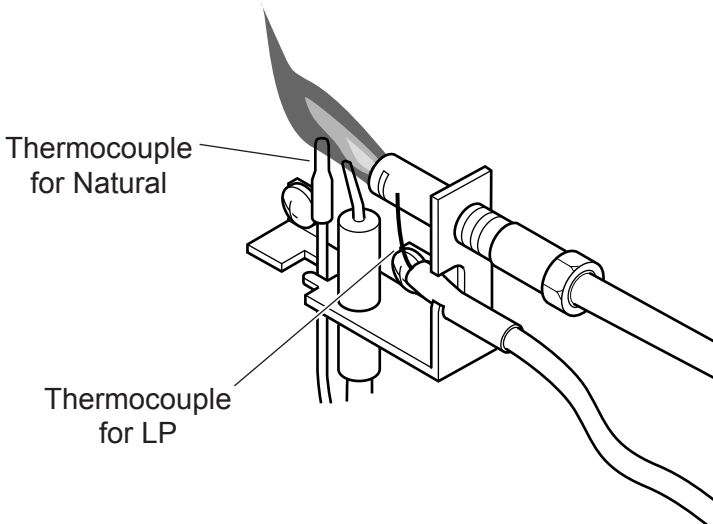


**Figure 38 - Correct Appearance of Pilot Flame**

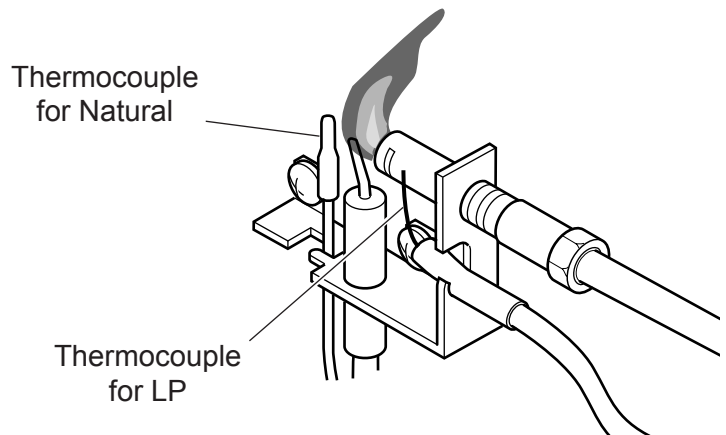


**Figure 39 - Incorrect Appearance of Pilot Flame**

## MANUAL CONTROL



**Figure 40 - Correct Appearance of Pilot Flame**



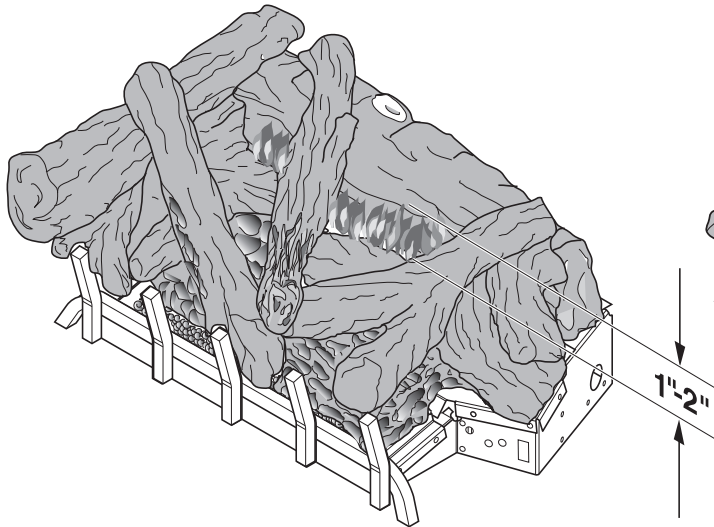
**Figure 41 - Incorrect Appearance of Pilot Flame**

---

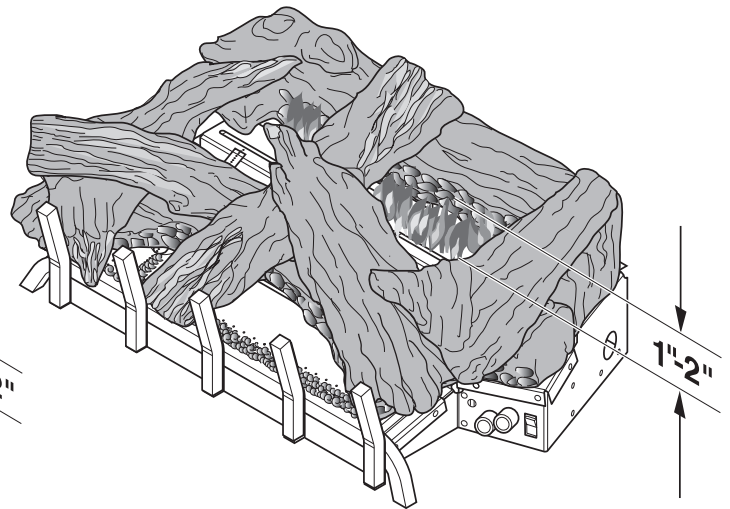
## CHECKING THE BURNER FLAME

---

In normal operation at full rate after 15 minutes, the following flame appearances should be observed:



**Figure 42 - Correct Appearance of Rear Flames of Kentucky Stack**



**Figure 43 - Correct Appearance of Rear Flames of Split Maple**

The left and right rear flames should be yellow and extend 1"-2" above the mid log top surfaces. The yellow flames should **not** contact the logs. There should be glowing embers on the front burner. **Note: The front flames and embers will be an opaque orange color during the burn off time.**

### OPERATING INSTRUCTIONS

**Avoid any drafts that alter burner flame patterns.** Do not allow fans to blow directly into the fireplace. Do not place a blower inside the burn area of the firebox. Ceiling fans may create drafts that alter flame patterns. Sooting and improper burning will result.

During manufacturing, fabricating and shipping, various components of this appliance are treated with certain oils, films or bonding agents. These chemicals are not harmful, but may produce annoying smoke and smells as they are burned off during the initial operation of the appliance, possibly causing headaches or eye or lung irritation. *This is a normal and temporary occurrence.*

The initial break-in operation should last two to three hours with the burner at the highest setting. Provide maximum ventilation by opening windows or doors to allow odors to dissipate. Any odors remaining after this initial break-in will be slight and will disappear with continued use.

This appliance must not be used with glass doors in the closed position. This can lead to pilot outages and severe sooting outside the fireplace. *See Figure 3, page 11.*

### FOR YOUR SAFETY READ BEFORE LIGHTING

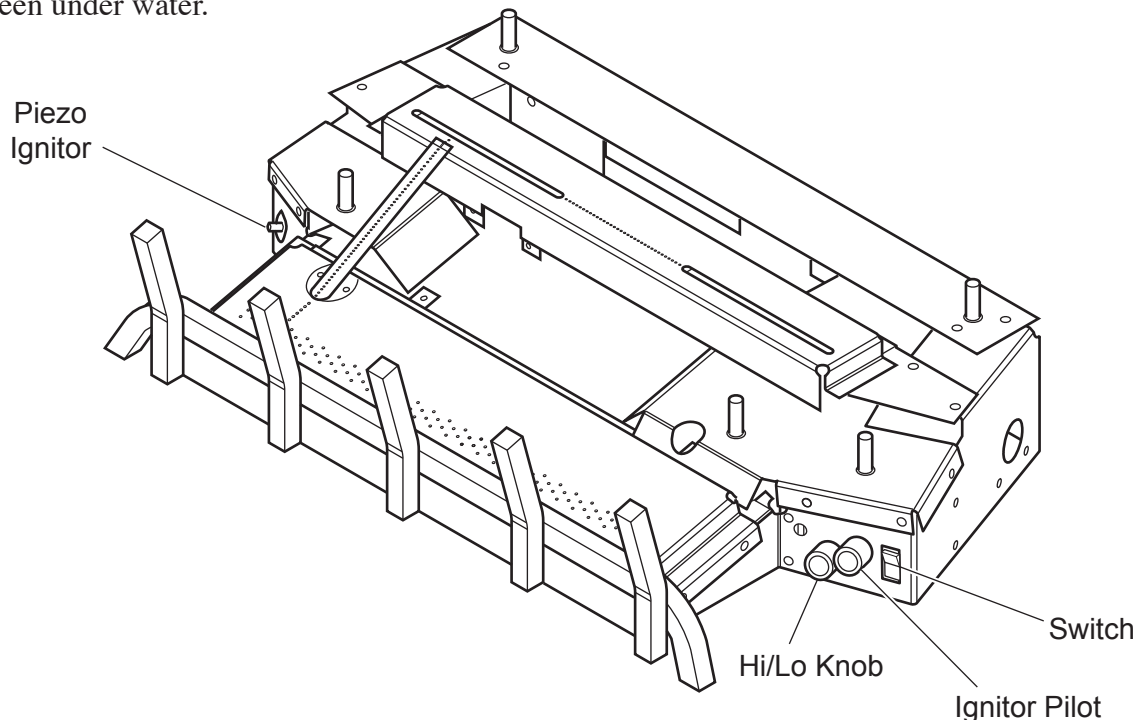
#### WARNING

If you do not follow these instructions exactly, a fire or explosion may result causing property damage, personal injury or loss of life.

- A.** This appliance is equipped with a piezo ignition device which lights the pilot. If piezo is not working properly see *Match Lighting Instructions*, page 35.
- B.** BEFORE OPERATING smell all around the appliance area for gas. Be sure to smell next to the floor because some gas is heavier than air and will settle on the floor.

#### WHAT TO DO IF YOU SMELL GAS:




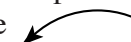
- Do not attempt to light any appliance.
  - Do not touch any electric switch; do not use any phone in your building.
  - Immediately call your gas supplier from a neighbor's phone. Follow the gas supplier's instructions.
  - If you cannot reach your gas supplier, call the fire department.
- C.** Use only your hand to push in, or turn the gas control knob. Never use tools. If the knob will not push in or turn by hand, don't try to repair it. Call a qualified service technician. Force or attempted repair may result in a fire or explosion.
- D.** Do not use this appliance if any part of it has been under water. Immediately call a qualified service technician to inspect the appliance and to replace any part of the control system and any gas control that has been under water.

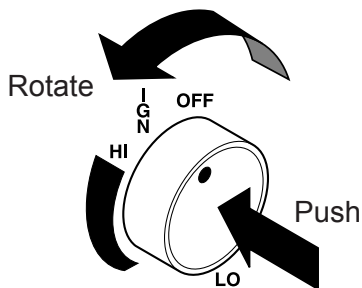


**Figure 44 - Location of Piezo Ignitor, Control Knobs and Switch on Milli-volt, Thermostat, and Manual Units**

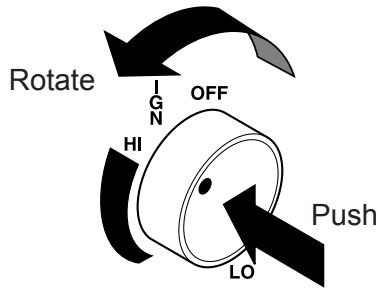


**MANUAL CONTROL LIGHTING INSTRUCTIONS**

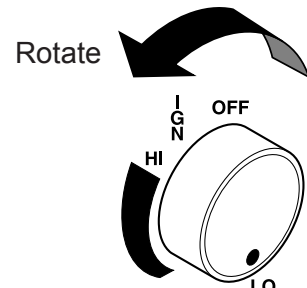
1. STOP! Read the safety information.
2. Make sure the manual shutoff valve is fully open.
3. This heater is equipped with an ignition device (piezo) which automatically lights the pilot.
4. See *Figure 44, page 32* for the location of the piezo ignitor and control knob. Push in gas control knob slightly and turn control knob clockwise  to the OFF position.  
**NOTE:** Knob cannot be turned to OFF unless knob is pushed in slightly. Do not force.
5. Wait 5 minutes to clear out any gas. Then smell for gas, including near the floor. If you smell gas STOP! Follow the instructions under *What To Do if You Smell Gas, page 32*. If you do not smell gas, go to the next step.
6. From OFF position, push in gas control knob slightly and turn counterclockwise  to the IGN position. See *Figure 45*. Push in and hold control knob for 5 seconds.  
**NOTE:** If you are running the heater for the first time, it will be necessary to press in the control knob for 30 seconds to allow air to bleed out of the gas piping.
7. With the control knob pushed in, push and release the piezo ignitor button to light the ODS pilot. The pilot is located on the left side of the heater, behind the middle log and on the back of the rear burner. If piezo ignitor does not light the pilot, refer to *Match Lighting Instructions, page 35*.
8. Hold the control knob in for an additional 10 seconds to prevent the ODS pilot from shutting off the gas while the thermocouple is warming up.
9. Release the control knob.
  - If the knob does not pop out when released, stop and immediately call your service technician or gas supplier.
  - If the ODS pilot will not stay lit after several tries, push and turn the gas control knob clockwise  to OFF and wait 15 seconds. Repeat steps 6 through 9.
10. Push in control knob and turn counterclockwise  to the HIGH setting. At this location the control knob will pop out when positioned correctly. The knob can now be positioned at any position between HIGH and LOW. Refer to *Figures 46 and 47*.



**Figure 45 - IGN Position**



**Figure 46 - HIGH Position**




**Figure 47 - LOW Position**

**WARNING**




Wait 30 seconds before readjusting the heater when the control knob has been turned down to a lower setting.

**TO TURN OFF GAS TO HEATER**

1. Turn control knob clockwise  to OFF position to completely shut off the heater.
2. If applicable: Turn off all electric power to the heater.

## OPERATING INSTRUCTIONS

### MILLI-VOLT CONTROL LIGHTING INSTRUCTION

1. STOP! Read the safety information label.
2. Make sure the manual shutoff valve is fully open.
3. This gas log set is equipped with an ignition device (piezo) which automatically lights the pilot. If piezo ignitor does not light the pilot, refer to instructions for *Match Lighting Instructions*, page 35.
4. Turn gas control knob clockwise  to the OFF position and turn ON/OFF switch to OFF position.
5. Wait (5) minutes to clear out any gas. Then smell for gas, including near the floor. If you smell gas, STOP! Follow the instructions under *What To Do If You Smell Gas*, page 32.
6. From OFF position, turn the gas control knob counterclockwise  to IGN position. Push in control knob for 5 seconds. **NOTE: If you are running the heater for the first time, it may be necessary to press in the control knob for 30 seconds or longer to allow air to bleed out of the gas piping.**
7. With the control knob pushed in, push in and release the piezo ignitor button to light the pilot.
8. Continue pushing the control knob in for a further 10 seconds to prevent the flame detector from shutting off the gas while the probe is warming up. Release the control knob.
9. Turn gas control knob counterclockwise  to the ON position.
10. After the pilot has been lit for one minute, the burners can be turned on. Turn the ON/OFF switch to ON position or adjust thermostat to desired setting. **NOTE: To use the thermostat function (if installed) the control knob must be set to "ON" and ON/OFF switch must be in the "OFF" position.**
11. If the gas logs will not operate, follow the instructions *To Turn Off Gas To Heater* below and call your service technician or gas supplier.

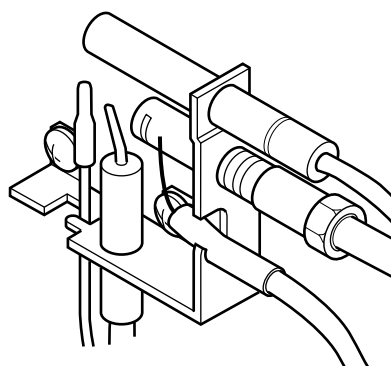


Figure 48 - Pilot

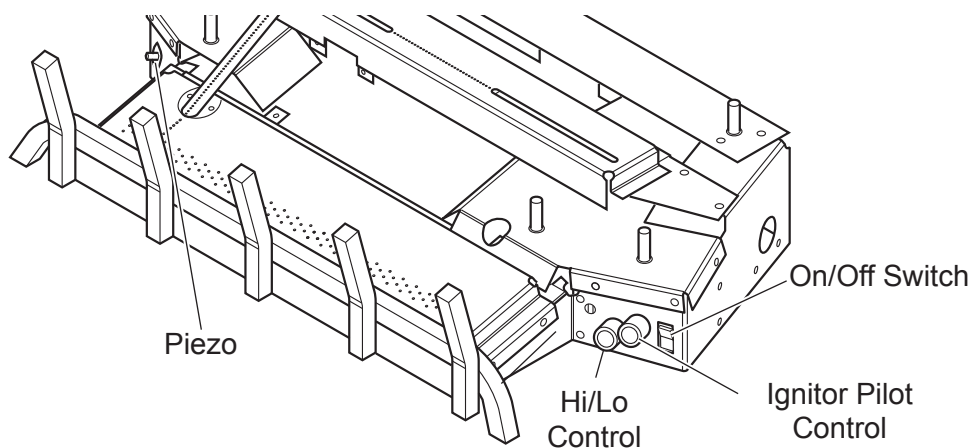



Figure 49 - Control Cover Plate for Milli-Volt

### TO TURN OFF GAS TO HEATER

1. Turn control knob clockwise  to OFF position to completely shut off the heater.
2. If applicable: Turn ON/OFF switch to OFF position and/or set thermostat (if present) to lowest setting.
3. If applicable: Turn off all electric power to the heater.

**MATCH LIGHTING INSTRUCTIONS**

1. Remove any items necessary for easy access to the pilot (for example: logs, screens, etc.).
2. Follow appropriate lighting instructions found previously. Instead of pushing and releasing the piezo button, light a match and hold the flame to the end of the pilot and ignite the pilot.
3. After control knob has been released and pilot stays lit, reinstall any items that were removed for pilot access.
4. Call a qualified service technician for repair or replacement of the piezo ignitor.

**CLEANING AND SERVICING**

**Annual inspection and cleaning by your dealer or qualified service technician is recommended to prevent malfunction and/or sooting.**

**WARNING**

**Turn off heater and allow to cool before cleaning. Disconnect electrical power before cleaning or servicing.**

Remove logs, handling carefully by holding gently at each end. Gloves are recommended to prevent skin irritation from ceramic fibers. If skin becomes irritated, wash gently with soap and water. Refer to manual for correct log placement.

**PERIODIC CLEANING - Refer to parts diagram for location of items discussed below.**

- Do not use cleaning fluid to clean logs or any part of heater.
- Brush logs with soft bristle brush or vacuum with brush attachment.
- Vacuum loose particles and dust from the front and rear burner, control and piezo covers and grate weldment.
- Inspect and clean burner air intake holes. Remove lint or particles with vacuum, brush, or pipe cleaners.  
**Failure to keep air intake holes clean will result in sooting and poor combustion.**
- External case should be dusted and wiped with a wet soapy cloth.

**ANNUAL CLEANING/INSPECTION - Refer to parts diagram for location of items discussed below.**

- Inspect and clean burner air intake holes. Remove lint or particles with vacuum, brush or pipe cleaners.  
**Failure to keep air intake holes clean will result in sooting and poor combustion.**
- Inspect and clean all burner ports.
- Inspect ODS pilot for operation and accumulation of lint at air intake holes.
- Verify flame pattern and log placement for proper operation.
- Verify smooth and responsive ignition of main burner and rear burner.
- Replace battery in remote control device.

# TROUBLESHOOTING

**WARNING**

Turn appliance OFF and allow to cool before servicing. Only a qualified service person should service and repair the heater.

*Note: All troubleshooting items are listed in order of operation.*

OBSERVED PROBLEM	POSSIBLE CAUSE	REMEDY
When ignitor button is pressed, there is no spark at ODS/pilot.	<ol style="list-style-type: none"> <li>1. Ignitor electrode positioned wrong.</li> <li>2. Ignitor electrode is broken.</li> <li>3. Ignitor electrode not connected to ignitor cable.</li> <li>4. Ignitor cable pinched or wet. Keep ignitor cable dry.</li> <li>5. Broken ignitor cable.</li> <li>6. Bad piezo ignitor.</li> </ol>	<ol style="list-style-type: none"> <li>1. Replace ignitor.</li> <li>2. Replace ignitor.</li> <li>3. Reconnect ignitor cable.</li> <li>4. Free ignitor cable if pinched by any metal or tubing.</li> <li>5. Replace ignitor cable.</li> <li>6. Replace piezo ignitor.</li> </ol>
Appliance produces unwanted odors.	<ol style="list-style-type: none"> <li>1. Appliance burning vapors from paint, hair spray, glues, etc.</li> <li>2. Gas leak.</li> <li>3. Initial burn off.</li> </ol>	<ol style="list-style-type: none"> <li>1. Ventilate room. Stop using odor causing products while heater is running.</li> <li>2. Locate and correct all leaks.</li> <li>3. Ventilate room and turn unit on high until odor is gone. Odor should be gone after 2 to 3 hours of continuous use.</li> </ol>
Appliance shuts off during use.	<ol style="list-style-type: none"> <li>1. Not enough fresh air is available for ODS/pilot to operate.</li> <li>2. Low line pressure.</li> <li>3. ODS/pilot is partially clogged.</li> <li>4. Defective Thermopile.</li> <li>5. Restrictions in incoming air flow.</li> </ol>	<ol style="list-style-type: none"> <li>1. Open window and/or door for ventilation.</li> <li>2. Contact local gas company.</li> <li>3. Clean ODS/pilot.</li> <li>4. Check wire connections. Check output should be 500 milli-volts across TH/TP and TP Terminals with ON/OFF switches off.</li> <li>5. Check for bottom riser on glass door, sunken fireplace, excessive lava rock/cinders densely packed against grate.</li> </ol>
Gas odor even when control knob is in OFF position.	<ol style="list-style-type: none"> <li>1. Gas leak.</li> <li>2. Control valve defective.</li> </ol>	<ol style="list-style-type: none"> <li>1. Locate and correct all leaks.</li> <li>2. Replace control valve.</li> </ol>
When ignitor button is pressed, there is spark at ODS pilot, but no ignition.	<ol style="list-style-type: none"> <li>1. Gas supply turned off or manual shutoff valve closed.</li> <li>2. Control knob not in PILOT position.</li> <li>3. Control knob not pressed in while in PILOT position.</li> <li>4. Air in gas lines when installed.</li> <li>5. ODS/pilot is clogged.</li> <li>6. Gas regulator setting is not correct.</li> </ol>	<ol style="list-style-type: none"> <li>1. Turn on gas supply or open manual shutoff valve.</li> <li>2. Turn control knob to PILOT position.</li> <li>3. Press in control knob while in PILOT position.</li> <li>4. Continue holding down control knob. Repeat igniting operation until air is removed.</li> <li>5. Replace ODS/pilot assembly or get it serviced.</li> <li>6. Check incoming pressure. Replace gas regulator.</li> </ol>

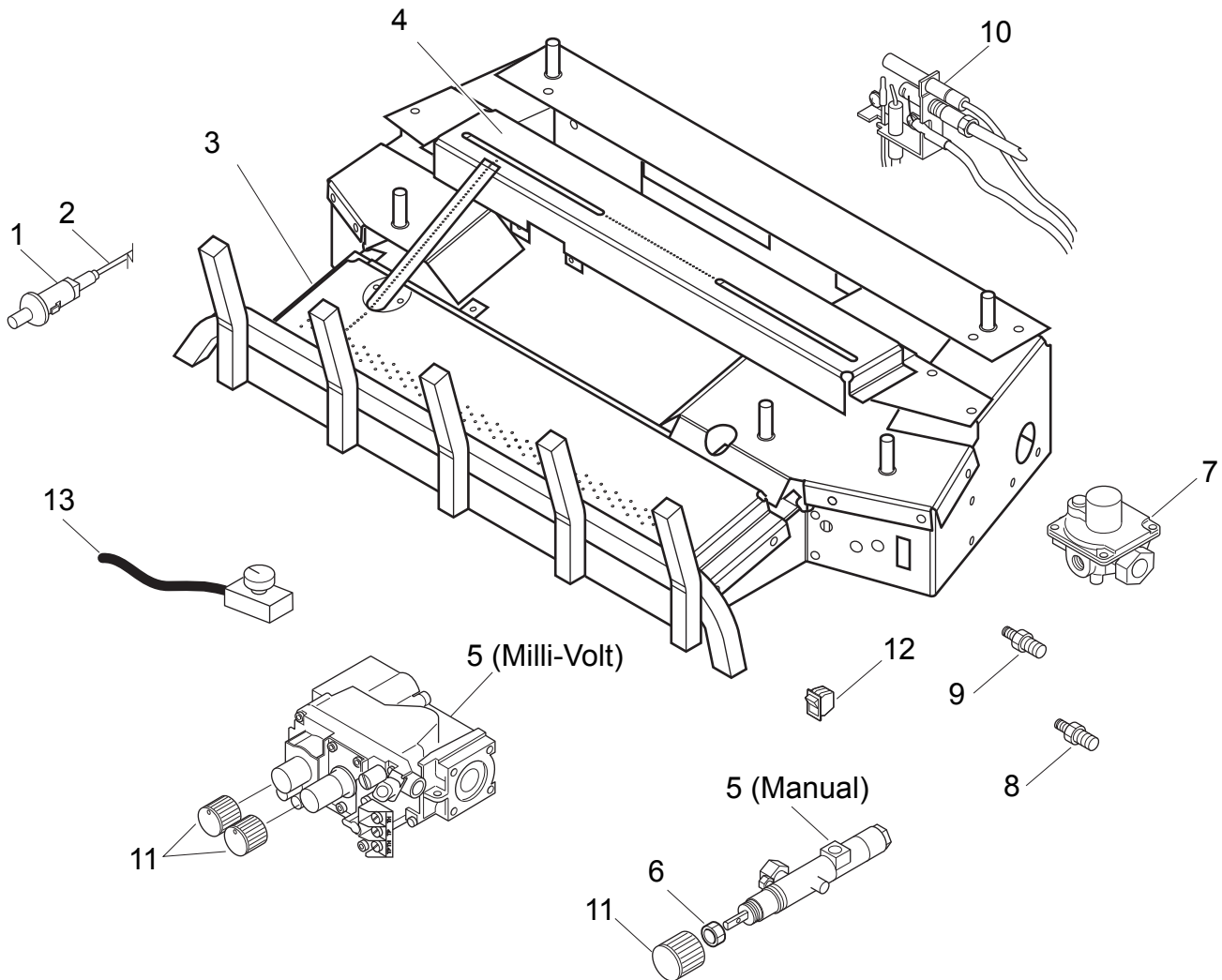
**WARNING**

If the gas quality is bad, your pilot may not stay lit, the burners may produce soot and the heater may backfire when lit. If the gas quality or pressure is low, contact your local gas supplier immediately.

OBSERVED PROBLEM	POSSIBLE CAUSE	REMEDY
<b>ODS/pilot lights, but flame goes out when control knob is released.</b>	<ol style="list-style-type: none"> <li>Control knob not fully pressed in.</li> <li>Control knob not pressed in long enough.</li> <li>Manual shutoff valve not fully open.</li> <li>Thermocouple connection loose at control valve.</li> <li>Pilot flame not touching thermocouple, which allows thermocouple to cool, causing pilot flame to go out. This problem could be caused by either low gas pressure, or a dirty or partially clogged ODS/pilot.</li> <li>Thermocouple damaged.</li> <li>Control valve damaged.</li> </ol>	<ol style="list-style-type: none"> <li>Press in control knob fully.</li> <li>After ODS/pilot lights, keep control knob pressed in for 30 seconds.</li> <li>Fully open manual shutoff valve.</li> <li>Hand tighten thermocouple connection until snug, then tighten 1/4 turn more.</li> <li>Contact local gas company.</li> <li>Replace thermocouple.</li> <li>Replace control valve.</li> </ol>
<b>Burner does not light after ODS/pilot is lit.</b>	<ol style="list-style-type: none"> <li>Burner orifice is clogged.</li> <li>Burner orifice diameter is too small.</li> <li>Inlet gas pressure is too low.</li> </ol>	<ol style="list-style-type: none"> <li>Clean orifice.</li> <li>Replace burner orifice.</li> <li>Contact qualified service person.</li> </ol>
<b>Burner backfires during combustion.</b>	<ol style="list-style-type: none"> <li>Manifold pressure is too low.</li> <li>Burner orifice is clogged.</li> </ol>	<ol style="list-style-type: none"> <li>Contact local gas company.</li> <li>Clean burner or replace burner orifice.</li> </ol>
<b>Slight smoke or odor during initial operation.</b>	<ol style="list-style-type: none"> <li>Burner orifice is clogged or damaged.</li> <li>Burner is damaged.</li> <li>Gas regulator defective.</li> </ol>	<ol style="list-style-type: none"> <li>Clean burner or replace burner orifice.</li> <li>Replace burner.</li> <li>Replace gas regulator.</li> </ol>
<b>Logs appear to smoke after initial operation.</b>	<ol style="list-style-type: none"> <li>Vapors from paint or curing process of logs.</li> </ol>	<ol style="list-style-type: none"> <li>Problem will stop after a few hours of operation. Run the heater with the damper open if you have one, or open a window for the first few hours.</li> <li>Log heater is intended to be smokeless. Turn OFF heater and call qualified service person.</li> </ol>
<b>Heater produces a whistling noise when burner is lit.</b>	<ol style="list-style-type: none"> <li>Turning control knob to HIGH position when burner is cold.</li> <li>Air in gas line.</li> <li>Dirty or partially clogged burner orifices.</li> </ol>	<ol style="list-style-type: none"> <li>Turn control knob to LOW position and let warm up for a minute.</li> <li>Operate burner until air is removed from line. Have gas line checked by local gas company.</li> <li>Clean burner or replace burner orifice.</li> </ol>
<b>No gas to pilot.</b>	<ol style="list-style-type: none"> <li>LP-regulator shut down due to inlet pressure too high.</li> </ol>	<ol style="list-style-type: none"> <li>Verify LP tank regulator is installed and set at 11" to 13" w.c.</li> <li>Replace regulator on heater.</li> </ol>

# REPLACEMENT PARTS

## BURNER ASSEMBLY



### WARNING

Failure to position the parts in accordance with these diagrams or failure to use only parts specifically approved with this appliance may result in property damage or personal injury.

# REPLACEMENT PARTS LIST

**REPLACEMENT PARTS ARE AVAILABLE THROUGH YOUR RETAILER.**

## BURNER ASSEMBLY

Item	Description	Qty	HVFL18		HVFL24	
			Natural	Propane	Natural	Propane
<b>Common Parts</b>						
1	Piezo Ignitor	1	14D0503	14D0503	14D0503	14D0503
2	Piezo Wire	1	00K0632	00K0632	00K0632	00K0632
3	Front Burner	1	59D0050	59D0050	59D0059	59D0059
4	Rear Burner	1	59D0058	59D0058	59D0051	59D0051
<b>Manual Control</b>						
5	Control Valve	1	30D0201	30D0202	30D0201	30D0202
6	Control Valve Nut	1	00F0586	00F0586	00F0586	00F0586
7	Valve Regulator	1	24D0305	24D0306	24D0305	24D0306
8	Front Burner Injector	1	59D2000	59D2002	59D2004	59D2006
9	Rear Burner Injector	1	59D2001	59D2003	59D2005	59D2007
10	ODS Pilot Assembly	1	26D2529	14D0476	26D2529	14D0476
11	Control Knob	1	18D0603	18D0603	18D0603	18D0603
<b>Milli-Volt Control</b>						
5	Control Valve	1	14D0467	14D0468	14D0467	14D0468
8	Front Burner Injector	1	59D2008	59D2010	59D2012	59D2014
9	Rear Burner Injector	1	59D2009	59D2011	59D2013	59D2014
10	ODS Pilot Assembly	1	14D0473	14D0477	14D0473	14D0477
11	Control Knob	2	18D0603	18D0603	18D0603	18D0603
12	On/Off Switch	1	32D0232	32D0232	32D0232	32D0232

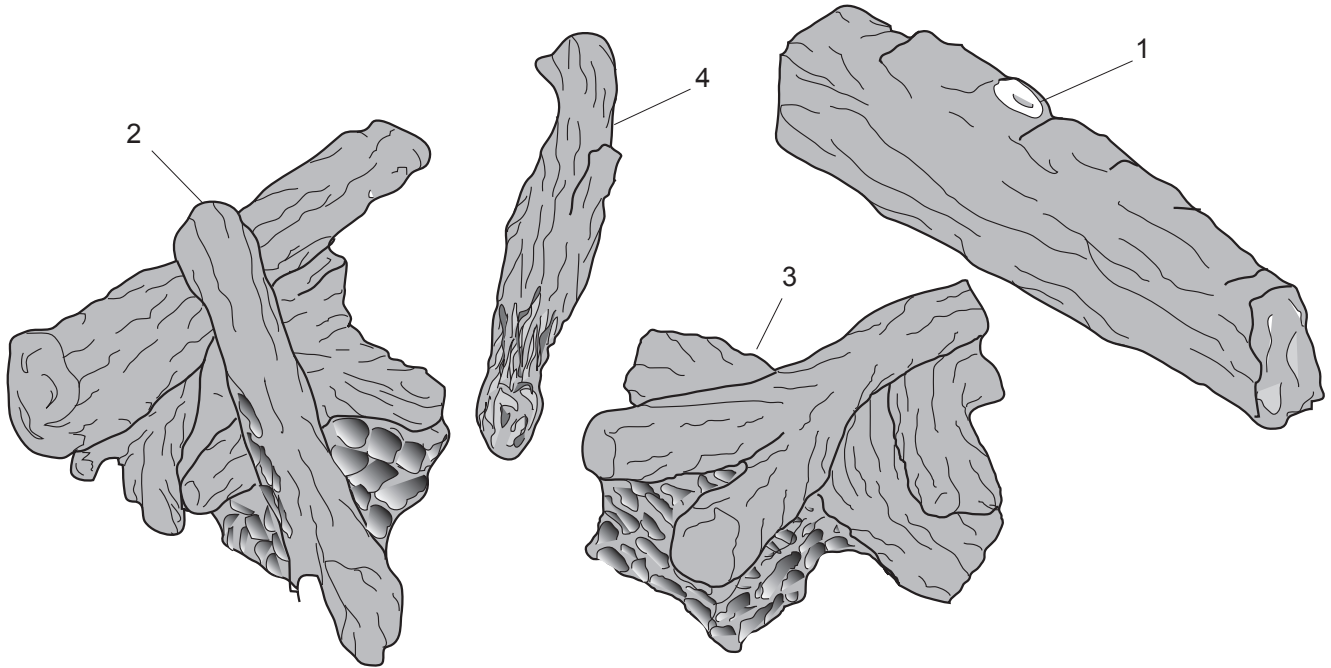
<b>Accessories Sold Separately</b>			
13	Thermostat Sensor	26D3314	All Models
	Thermostat Sensor Kit	TS	All Models
	Flex Connector	Flexcon 30	All Models
	Wall Switch Kit	MVWS	Milli-volt only
	Wall Thermostat Kit	MVWTS	Milli-volt only
	Hand Held Remote	RCM	Milli-volt only
	Hand Held Thermostat Remote	RCT	Milli-volt only
	Remote Receiver Cover Ember	RRCE	All Models
	Remote Receiver Cover Metal	RRCM	All Models
	Touch Light Manual	TLM	All New Remotes
	Touch Light T-stat	TLT	All Models

# REPLACEMENT PARTS LIST

REPLACEMENT PARTS ARE AVAILABLE THROUGH YOUR RETAILER.

## KENTUCKY STACK LOGS

Item	Description	Qty	KSCL18	KSCL24	KSCL30
1	Back Log	1	59D1238K	59D1248K	59D1258K
2	Left Log Cluster	1	59D1234K	59D1244K	59D1254K
3	Right Log Cluster	1	59D1230K	59D1240K	59D1250K
4	Top Center Log	1	59D1239K	59D1249K	59D1259K



### WARNING

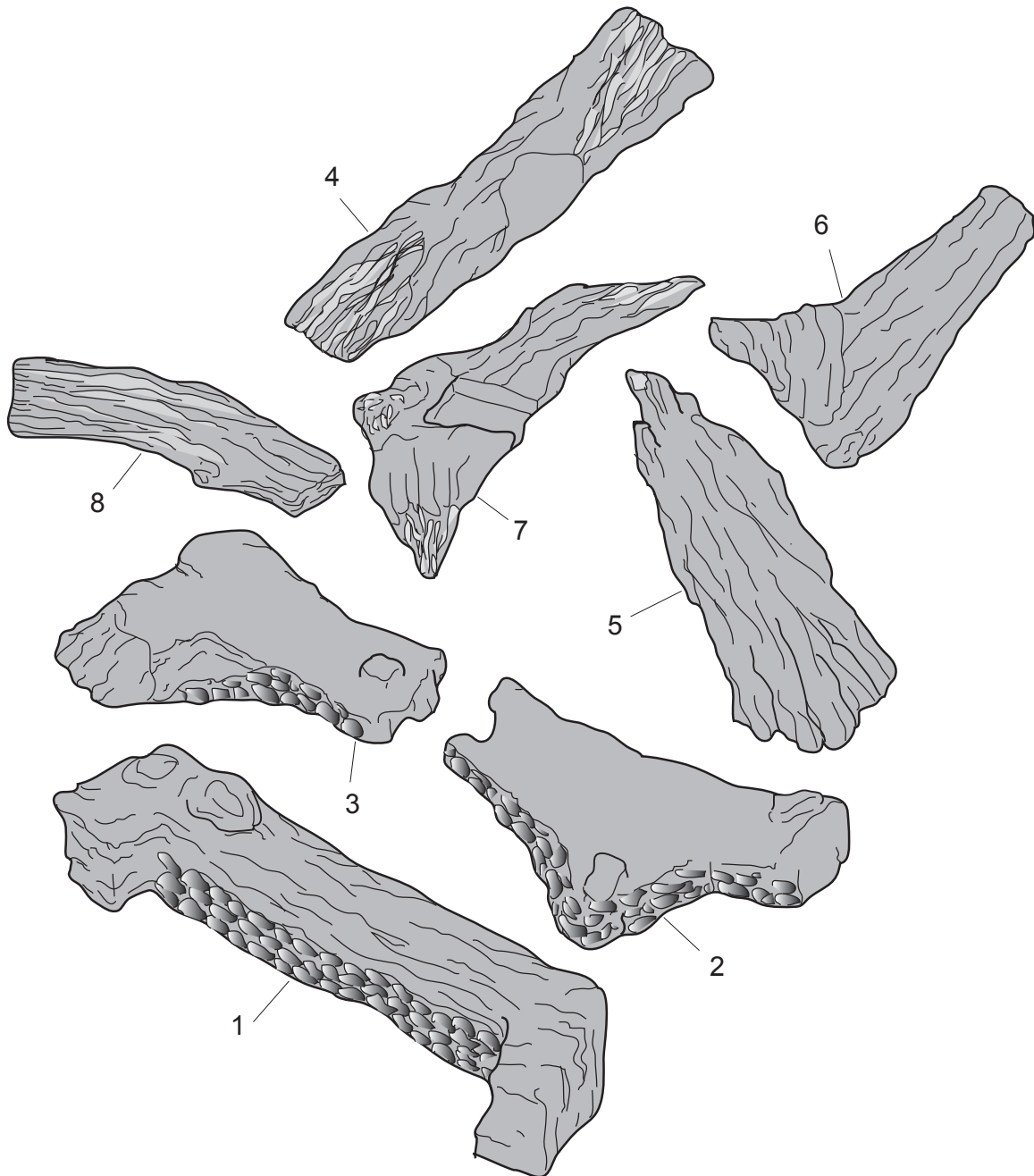
Failure to position the parts in accordance with these diagrams or failure to use only parts specifically approved with this appliance may result in property damage or personal injury.



*REPLACEMENT PARTS ARE AVAILABLE THROUGH YOUR RETAILER.*

**SPLIT MAPLE LOGS**

Item	Description	Qty	SMRL18	SMRL24	SMRL30
1	Back Log	1	59D1260	59D1268	59D1276
2	Right Bottom Log	1	59D1261	59D1269	59D1277
3	Left Bottom Log	1	59D1262	59D1270	59D1278
4	Top Center Lot	1	59D1266	59D1274	59D1325
5	Top Right Middle Log	1	59D1267	59D1275	59D1326
6	Right Rear-To-Middle Log	1	59D1264	59D1272	59D1280
7	Right Left-To-Middle Log	1	59D1263	59D1271	59D1279
8	Left Front Log	1	59D1265	59D1273	59D1281



# MASSACHUSETTS RESIDENTS ONLY: PLEASE READ AND FOLLOW THESE SPECIAL REQUIREMENTS

---

## **NOTE REGARDING VENTED PRODUCTS**

This product must be installed by a licensed plumber or gas fitter when installed within the Commonwealth of Massachusetts.

Any residence with a direct vent product must have a CO detector installed in the residence.

Installation of the fireplace or vented gas log in the State of Massachusetts requires the damper to be permanently removed or welded in the fully open position.

In addition, a naturally vented gas log may not be installed in a bedroom or bathroom in the State of Massachusetts.

Flex line installation must not exceed 36 inches and must have a T shutoff valve.

## **NOTE REGARDING VENT FREE PRODUCTS**

This product must be installed by a licensed plumber or gas fitter when installed within the Commonwealth of Massachusetts.

In addition, vent free products may not be installed in a bedroom or bathroom regardless of size or type in the State of Massachusetts.

Flex line installation must not exceed 36 inches and must have a T shutoff valve.

## **CARBON MONOXIDE DETECTOR REQUIREMENTS**

(2) Revise 10.8.3 by adding the following additional requirements:

(a) For all side wall horizontally vented gas fueled equipment installed in every dwelling, building or structure used in whole or in part for residential purposes, including those owned or operated by the Commonwealth and where the side wall exhaust vent termination is less than seven (7) feet above finished grade in the area of the venting, including but not limited to decks and porches, the following requirements shall be satisfied:

1. **INSTALLATION OF CARBON MONOXIDE DETECTORS.** At the time of installation of the side wall horizontal vented gas fueled equipment, the installing plumber or gasfitter shall observe that a hard wired carbon monoxide detector with an alarm and battery back-up is installed on the floor level where the gas equipment is to be installed. In addition, the installing plumber or gasfitter shall observe that a battery operated or hard wired carbon monoxide detector with an alarm is installed on each additional level of the dwelling, building or structure served by the side wall horizontal vented gas fueled equipment. It shall be the responsibility of the property owner to secure the services of qualified licensed professionals for the installation of hard wired carbon monoxide detectors
    - a. In the event that the side wall horizontally vented gas fueled equipment is installed in a crawl space or an attic, the hard wired carbon monoxide detector with alarm and battery back-up may be installed on the next adjacent floor level.
    - b. In the event that the requirements of this subdivision can not be met at the time of completion of installation, the owner shall have a period of thirty (30) days to comply with the above requirements; provided, however, that during said thirty (30) day period, a battery operated carbon monoxide detector with an alarm shall be installed.
-

## SPECIAL REQUIREMENTS CONTINUED

---

2. APPROVED CARBON MONOXIDE DETECTORS. Each carbon monoxide detector as required in accordance with the above provisions shall comply with NFPA 720 and be ANSI/UL 2034 listed and IAS certified.
  3. SIGNAGE. A metal or plastic identification plate shall be permanently mounted to the exterior of the building at a minimum height of eight (8) feet above grade directly in line with the exhaust vent terminal for the horizontally vented gas fueled heating appliance or equipment. The sign shall read, in print size no less than one-half (1/2) inch in size, **“GAS VENT DIRECTLY BELOW. KEEP CLEAR OF ALL OBSTRUCTIONS.”**
  4. INSPECTION. The state or local gas inspector of the side wall horizontally vented gas fueled equipment shall not approve the installation unless, upon inspection, the inspector observes carbon monoxide detectors and signage installed in accordance with the provisions of 248 CMR 5.08(2)(a)1 through 4.
- (b) EXEMPTIONS: The following equipment is exempt from 248 CMR 5.08(2)(a)1 through 4:
1. The equipment listed in Chapter 10 entitled “Equipment Not Required To Be Vented” in the most current edition of NFPA 54 as adopted by the Board; and
  2. Product Approved side wall horizontally vented gas fueled equipment installed in a room or structure separate from the dwelling, building or structure used in whole or in part for residential purposes.
- (c) MANUFACTURER REQUIREMENTS - GAS EQUIPMENT VENTING SYSTEM PROVIDED. When the manufacturer of Product Approved side wall horizontally vented gas equipment provides a venting system design or venting system components with the equipment, the instructions provided by the manufacturer for installation of the equipment and the venting system shall include:
1. Detailed instructions for the installation of the venting system design or the venting system components; and
  2. A complete parts list for the venting system design or venting system.
- (d) MANUFACTURER REQUIREMENTS - GAS EQUIPMENT VENTING SYSTEM NOT PROVIDED. When the manufacturer of a Product Approved side wall horizontally vented gas fueled equipment does not provide the parts for venting the flue gases, but identifies “special venting systems,” the following requirements shall be satisfied by the manufacturer:
1. The referenced “special venting system” instructions shall be included with the appliance or equipment installation instructions; and
  2. The “special venting systems” shall be Product Approved by the Board, and the instructions for that system shall include a parts list and detailed installation instructions.
- (e) A copy of all installation instructions for all Product Approved side wall horizontally vented gas fueled equipment, all venting instructions, all parts lists for venting instructions, and/or all venting design instructions shall remain with the appliance or equipment at the completion of the installation.
-

# MONESSEN HEARTH SYSTEMS

## LIMITED LIFETIME WARRANTY POLICY

### LIFETIME WARRANTY

The following components are warranted for life to the original owner, subject of proof of purchase: Firebox, Combustion Chamber, Heat Exchanger, Grate, and Stainless Steel Burners.

### FIVE YEAR WARRANTY

The following components are warranted for 5 years to the original owner, subject of proof of purchase: Vent Free Ceramic Fiber Logs and Aluminized Burners.

### BASIC WARRANTY

Monessen Hearth Systems (MHS) warrants the components and materials in your gas appliance to be free from manufacturing and material defects for a period of two years from date of installation. After installation, if any of the components manufactured by MHS in the appliance are found to be defective in materials or workmanship, MHS will, at its option, replace or repair the defective components at no charge to the original owner. MHS will also pay for reasonable labor costs incurred in replacing or repairing such components for a period of two years from the date of installation. Any products presented for warranty repair must be accompanied by a dated proof of purchase.

This Limited Lifetime Warranty will be void if the appliance is not installed by a qualified installer in accordance with the installation instructions. The Limited Lifetime Warranty will also be void if the appliance is not operated and maintained according to the operating instructions supplied with the appliance, and does not extend to (1) firebox/burner assembly damage by accident, neglect, misuse, abuse, alteration, negligence of others, including the installation thereof by unqualified installers, (2) the costs of removal, reinstallation or transportation of defective parts on the appliance, or (3) incidental or consequential damage. All service work must be performed by an authorized service representative.

This warranty is expressly in lieu of other warranties, express or implied, including the warranty of merchantability of fitness for purpose and of all other obligations or liabilities. Monessen Hearth Systems, Inc. does not assume for it any other obligations or liability in connection with the sale or use of the appliance. In states that do not allow limitations on how long an implied warranty lasts, or do not allow exclusion of indirect damage, those limitations of exclusions may not apply to you. You may also have additional rights not covered in this Limited Lifetime Warranty.

MHS reserves the right to investigate any and all claims against the Limited Lifetime Warranty and decide upon method of settlement.

For information about this warranty, contact:

**Technical Services  
Monessen Hearth Systems  
149 Cleveland Drive  
Paris, Kentucky 40361**