

MONESSEN HEARTH SYSTEMS

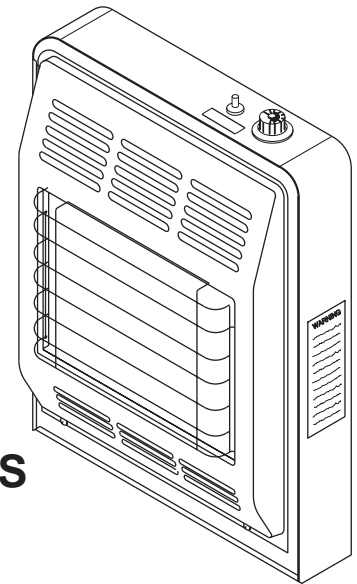

IRVF2T, IRVF3T, AND IRVF5T MODELS INFRARED UNVENTED ROOM HEATERS WITH THERMOSTAT CONTROL

INSTALLATION, OPERATION AND MAINTENANCE MANUAL

THE DESIGN OF THIS HEATER COMPLIES WITH STANDARD Z21.11.2 OF THE AMERICAN NATIONAL STANDARDS INSTITUTE AS CERTIFIED BY CSA INTERNATIONAL.

THIS APPLIANCE MAY BE INSTALLED IN AN AFTERMARKET, PERMANENTLY LOCATED, MANUFACTURED (MOBILE) HOME, WHERE NOT PROHIBITED BY LOCAL CODES.

THIS APPLIANCE IS ONLY FOR USE WITH THE TYPE OF GAS INDICATED ON THE RATING LABEL. THIS APPLIANCE IS NOT CONVERTIBLE FOR USE WITH OTHER GASES.

WARNING: IF THE INFORMATION IN THIS MANUAL IS NOT FOLLOWED EXACTLY, A FIRE OR EXPLOSION MAY RESULT CAUSING PROPERTY DAMAGE, PERSONAL INJURY OR LOSS OF LIFE.

DO NOT STORE OR USE GASOLINE OR OTHER FLAMMABLE VAPORS AND LIQUIDS IN THE VICINITY OF THIS OR ANY OTHER APPLIANCE.

WHAT TO DO IF YOU SMELL GAS

- **DO NOT TRY TO LIGHT ANY APPLIANCE.**
- **DO NOT TOUCH ANY ELECTRICAL SWITCH; DO NOT USE ANY PHONE IN YOUR BUILDING.**
- **IMMEDIATELY CALL YOUR GAS SUPPLIER FROM A NEIGHBOR'S PHONE. FOLLOW THE GAS SUPPLIER'S INSTRUCTIONS.**
- **IF YOU CANNOT REACH YOUR GAS SUPPLIER, CALL THE FIRE DEPARTMENT.**

INSTALLATION AND SERVICE MUST BE PERFORMED BY A QUALIFIED INSTALLER, SERVICE AGENCY OR THE GAS SUPPLIER.

THIS IS AN UNVENTED GAS-FIRED HEATER. IT USES AIR (OXYGEN) FROM THE ROOM IN WHICH IT IS INSTALLED. PROVISIONS FOR ADEQUATE COMBUSTION AND VENTILATION AIR MUST BE PROVIDED. REFER TO COMBUSTION AND VENTILATION AIR REQUIREMENTS SECTION OF THIS MANUAL FOR DETAILS.

TABLE OF CONTENTS

Your heater has been designed for years of safe, efficient, and trouble-free operation provided the instructions in this manual are followed. To help insure your safety, it is very important that you take time to read this entire manual before installing or operating this heater.

Important Information	1
Parts Diagram and List	2-3
How This Appliance Operates	4
Selecting A Location	5-6
Gas Piping and Pressure Requirements	7-8
Combustion and Ventilation Air Requirements	9-10
Installation and Adjustment	11-15
Lighting and Operating Heater	16-17
Safety Checklist	18
Maintenance	19
Troubleshooting	20
Warranty	21

CAUTION

- **DUE TO HIGH TEMPERATURES, THE HEATER SHOULD BE LOCATED OUT OF TRAFFIC AND AWAY FROM FURNITURE AND DRAPERIES.**
 - **CHILDREN AND ADULTS SHOULD BE ALERTED TO THE HAZARD OF HIGH SURFACE TEMPERATURE AND SHOULD STAY AWAY TO AVOID BURNS OR CLOTHING IGNITION.**
 - **YOUNG CHILDREN SHOULD BE CAREFULLY SUPERVISED WHEN THEY ARE IN THE SAME ROOM WITH THE HEATER.**
 - **DO NOT PLACE CLOTHING OR OTHER FLAMMABLE MATERIAL ON OR NEAR THE HEATER.**
 - **ANY SAFETY SCREEN OR GUARD REMOVED FOR SERVICING THE HEATER MUST BE REPLACED PRIOR TO OPERATING THE HEATER.**
 - **INSTALLATION AND REPAIR SHOULD BE PERFORMED ONLY BY A QUALIFIED SERVICE PERSON.**
 - **THE HEATER SHOULD BE INSPECTED BEFORE USE AND CLEANED AND INSPECTED AT LEAST ANNUALLY BY A PROFESSIONAL SERVICE PERSON. MORE FREQUENT CLEANING MAY BE REQUIRED DUE TO EXCESSIVE LINT FROM CARPETING, BEDDING MATERIAL, ETC. IT IS IMPERATIVE THAT CONTROL COMPARTMENTS, BURNERS AND CIRCULATING-AIR PASSAGEWAYS OF THE HEATER BE KEPT CLEAN.**
 - **THIS APPLIANCE IS INTENDED FOR SUPPLEMENTAL HEATING.**
- FOR MASSACHUSETTS RESIDENCES ONLY:**
- **THIS PRODUCT MUST BE INSTALLED BY A LICENSED PLUMBER OR GAS FITTER WHEN INSTALLED WITHIN THE COMMONWEALTH OF MASSACHUSETTS. FLEXLINE INSTALLATION MUST NOT EXCEED 36 INCHES.**

WARNING: ANY CHANGE TO THIS HEATER OR ITS CONTROLS CAN BE DANGEROUS.

WARNING: FAILURE TO KEEP THE PRIMARY AIR OPENINGS OF THE BURNERS CLEAN MAY RESULT IN SOOTING AND PROPERTY DAMAGE.

IMPORTANT INFORMATION

Study these instructions carefully before beginning the installation of this heater. These instructions contain information to be used as a guide during the installation and use of this heater. Critically important safety information is provided in gray blocks along the edges of many pages. These instructions must be followed for safe, efficient, and trouble-free operation of this heater.

Before installing the heater, inspect it thoroughly for shipping damage and missing parts. If any damage or missing parts are detected, report this to the dealer from whom you purchased the heater and get the deficiency corrected before installing and using the heater. **Do not install or use a damaged or incomplete heater.**

The installer of this heater must describe the operation of the heater to the people who will be operating it and leave this instruction manual with the operator of the heater.

Do not use this room heater if any part has been under water. Immediately call a qualified service technician to inspect the room heater and to replace any part of the control system and any gas control which has been under water.

When properly installed, used and maintained, this heater should not produce carbon monoxide in dangerous quantities. However, since carbon monoxide can be deadly poisonous, the installer and all users of this heater should read and follow these instructions carefully.

The type gas this heater is equipped for, and the only type gas supply it should be attached to, is specified on a label affixed to the heater's left side reflector located just behind the cabinet front. An additional label indicating the correct gas type is affixed to the bottom of the heater.

The input rating in Btu/hr for each of the heaters described by this manual is as specified below in Table 1.

TABLE 1

MODEL NUMBER OF HEATER	NUMBER OF BURNER PLAQUES IN HEATER	BTU/HR INPUT FOR HEATERS EQUIPPED WITH LP GAS	BTU/HR INPUT FOR HEATERS EQUIPPED WITH NATURAL GAS
IRVF2T	2	10,000	10,000
IRVF3T	3	15,000	18,000
IRVF5T	5	25,000	30,000

WARNING: Do NOT ALLOW FANS TO BLOW DIRECTLY INTO THE FIREPLACE. AVOID ANY DRAFTS THAT ALTER BURNER FLAME PATTERNS.

Danger: This heater, as any gas-fired appliance, can produce poisonous carbon monoxide along with other combustion products. Carbon monoxide, in strong concentrations, can cause sickness, serious personal injury and death.

Early signs of carbon monoxide poisoning resemble the flu, with headache, dizziness and/or nausea. If you have these signs, the heater may not be working properly. **Get fresh air at once! Immediately have heater serviced by a qualified technician.**

Some people (pregnant women, persons with heart or lung disease, anemia, those under the influence of alcohol, those at high altitudes) are more affected by carbon monoxide than others.

Danger: Operation of this heater on gases for which it is not equipped may lead to carbon monoxide poisoning.

Warning: This heater cannot be converted to a gas other than the type for which it was equipped at the factory.

Warning: Any change to this heater or its controls can be dangerous.

PARTS DIAGRAM

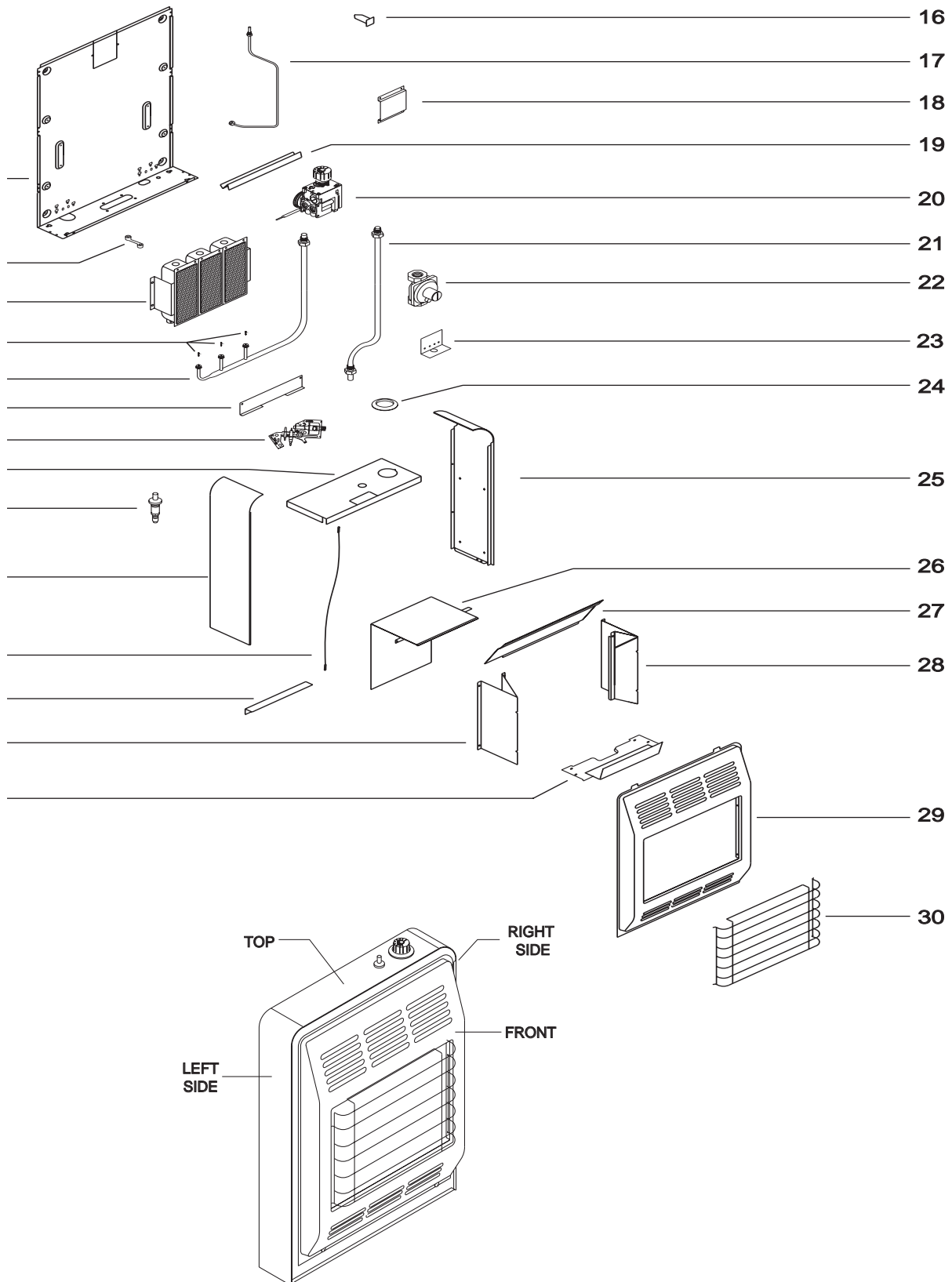

PARTS LIST

All repair part orders should be placed through your local dealer. To ensure prompt and accurate service, please provide the following information when placing a repair part order: Model number of your Appliance, Part Name, Part Number, and Quantity of parts needed. **Do NOT TAKE A HEATER NEEDING REPAIR, OR BELIEVED TO BE DEFECTIVE, BACK TO THE SELLER.**

KEY NO.	DESCRIPTION	QTY. PER HEATER	IRVF2T PART NO.	IRVF3T PART NO.	IRVF5T PART NO.
1	Cabinet Back Pntd.	1	077519	077520	078040
2	Speed Nut 10-24 U Type	4	050889	050889	050889
3	Clamp, Thermostat Bulb	2	P549	P549	P549
4	Burner Assembly	1	072285	072286	072287
5	Orifice (LP Gas)	see ()	072085 (2)	072085 (3)	072085 (5)
	Orifice (Nat Gas)	see ()	072084 (2)	072084 (3)	072084 (5)
6	Burner Tube Assembly	1	072420	072422	072424
7	Venturi Shield	1	058711	055872	055874
8	Pilot (LP Gas)	1	14D0476	14D0476	14D0476
	Pilot (NAT Gas)	1	26D2529	26D2529	26D2529
9	Cabinet Top w/Caution Label	1	074034	074035	074036
10	Piezo Ignitor	1	071040	071040	071040
11	Cabinet Side Left W/Labels	1	078074	078074	078074
12	Piezo Cable	1	067972	067972	067972
13	Brace Reflector	1	049863		
14	Reflector, Left Side Pntd.	1	069104	069104	069104
15	Front Shield & Hearth Plate Assembly	1	074039	074040	074041
16	Wall Anchor	2	052997	052997	052997
17	Pilot Tube Assembly	1	072419	072421	072423
18	Control Bracket Assembly Pntd.	1	054461	054461	054461
19	Burner Shield	1	055878	055873	055875
20	Thermostat Control	1	072090	072090	072090
21	Regulator To Control Tube Assembly	1	072425	072425	072425
22	Regulator (LP Gas)	1	072088	072088	072088
	Regulator (NAT Gas)	1	072086	072087	072087
23	Regulator Bracket	1	071705	071705	071705
24	Control Ring	1	051041	051041	051041
25	Cabinet Side Right W/Markings	1	078073	078073	078073
26	Heat Shield Weld Assembly	1		055870	050980
27	Deflector Pntd.	1	075278	075279	075280
28	Reflector, Right Side Pntd.	1	069103	069103	069103
29	Cabinet, Front Pntd.	1	072330	072337	072344
30	Dress Guard	1	072334	072341	072348

HOW THIS APPLIANCE OPERATES

Warning: This heater is hot while in operation. Do not touch. Keep children, clothing and furniture away. Never operate this heater without the factory-installed dress guard in place. Never use this heater to dry clothes, cook on, or for any other purpose other than providing heat to the area around the heater.

Notice: The heater will go through a curing process during its initial (first 2 to 3 hours) operating period and may emit some smoke and fumes (burning off oil, etc.). Be prepared for any smoke and fumes by raising windows or opening doors to provide additional ventilation during this initial operating period.

This heater is to be installed either wall mounted or freestanding according to these instructions and must **not** be enclosed within a confined space or within a cabinet. It is intended to provide heat directly to the space in which it is located. The heater is designed, tested and built to operate safely, when installed according to these instructions, in areas built of material common to residential construction. Any alteration of the heater or any installation and use not in accordance with these instructions may be hazardous. Refer to "SELECTING A LOCATION" and "COMBUSTION AND VENTILATION AIR REQUIREMENTS" sections of this manual for details.

The heater's burner plaques produce heat as soon as they are lit. During operation, the heater gives off infrared radiant heat which travels through the air and heats nearby objects first, then heats the room air.

The control system on this heater is a safety system that must not be tampered with. Do not attempt to make any adjustments to the control or pilot other than those described in the "INSTALLATION AND ADJUSTMENT" or "TROUBLESHOOTING" sections of this manual.

The control system on this heater serves several functions. It regulates the incoming gas to the correct pressure for the combustion rate required. It will not regulate LP gas directly from the container; a separate regulator must be installed on the tank or bottle to reduce the gas pressure supplied to the heater to between 11 and 13 inches water column. The control system also provides a safety shutoff to allow gas to flow to the burner assembly only when the pilot is burning and to shut off gas to both the pilot and burner assembly should the pilot flame not be burning. The control system provides a manual valve to turn gas on and off to the burner assembly. The control has a thermostat which automatically shuts off the burner assembly when the room reaches a selected temperature. There is a safety feature in the control valve which will lock the control knob in the 'Off' position until the pilot valve closes, should the control knob be accidentally turned to 'Off' while the pilot is burning; this prevents escape of unburned gases. The control system also regulates the pilot gas flow as required for proper operation and provides for shutoff of the gas to the pilot and burner assembly before the oxygen in the area of the heater is depleted to dangerous levels.

Air is pulled into the burner assembly by the gas stream and mixed with the gas inside the burner assembly before burning. Additional air required to complete the burning of the gas enters the heater through its front. See the "COMBUSTION AND VENTILATION AIR REQUIREMENTS" section of this manual. Blocking or altering air flow into and away from the heater could cause improper combustion and the production of carbon monoxide gas that could accumulate to hazardous concentrations. To prevent a disruption of the air flow through the heater, keep the heater clean as described by the "MAINTENANCE" section of this manual.

SELECTING A LOCATION

These heaters are shipped from the factory equipped for mounting on a flat wall. A wall-mount template is provided with each heater to aid in locating the heater on a wall. Maintaining at least the minimum spacing to combustibles as illustrated by Figure 1 is required for safety. Using the wall-mount template will help ensure that the required minimum clearances between the heater and adjacent walls, floor, and ceiling are maintained when mounting the heater on a wall.

The wall-mount anchors provided with each heater are for mounting the heater to a hollow wall (wall area between studs.) If the heater is to be mounted to a solid wall such as concrete or masonry, these wall-mount anchors should not be used. Obtain appropriate solid wall-mount anchors with number 10 mounting screws from your local hardware store.

The minimum clearances (see Figure 1) between combustible materials and a wall mounted heater are:

- Back - 0 inches (mount directly on wall).
- Floor - 3 inches
- Sides - 12 inches on one side of the heater;
18 inches on the opposite side of the heater.
- Top - 36 inches
- Front - 48 inches

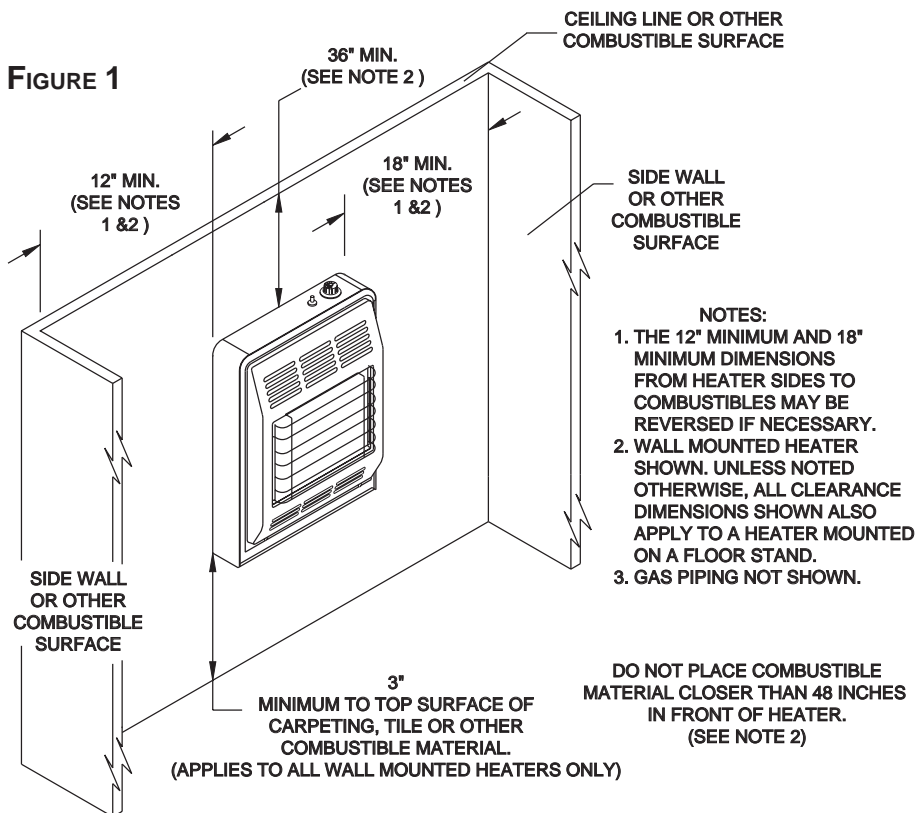

Danger: Do not install this heater in any area where gasoline or any combustible or explosive material will be used or stored. The flame from this heater is exposed to the area around the heater. Contact with explosive or flammable materials will lead to explosion or fire.

SELECTING A LOCATION

Danger: Operation of the heater as a freestanding heater without the proper floor stand correctly installed may lead to fire or the production of carbon monoxide gas.

Warning: If heater is installed and operated at clearances less than those specified as minimum in these instructions, a fire hazard may exist with possible fire causing property damage or personal injury. If the heater is operated at clearances less than those specified in these instructions, insufficient air may be supplied to the heater causing poisonous carbon monoxide to be produced.

Notice: The Z21.11.2 standard of the American National Standards Institute prohibits the installation of a heater with a rating greater than 6,000 Btu's per hour in a bathroom. The standard also prohibits the installation of a heater with a rating greater than 10,000 Btu's per hour in a bedroom.

Warning: Failure to adequately protect the flooring materials under a floor mounted heater can lead to damaged flooring material or fire.

A floor stand model XFS is available from your dealer. The floor stand enables these heaters to be installed freestanding as shown by Figure 2.

The minimum clearances (see Figure 1) between combustible material and a freestanding heater installed on a floor stand are:

- Back - 0 inches (floor stand may touch rear wall)
- Floor - 0 inches (floor stand may rest directly on floor - See "FLOOR PROTECTION" information below.)
- Sides - 12 inches on one side of the heater;
18 inches on the opposite side of the heater.
- Top - 36 inches
- Front - 48 inches

When selecting a location for the heater, be sure attention is given to the following considerations.

1. Some materials such as vinyls and plastics will deform at relatively low temperatures and must be kept at greater clearance distances than the minimum clearances specified above.
2. The heater should be located centrally within the area where heat is desired, but out of traffic areas, or areas where children play, to minimize the chance of persons accidentally contacting the hot surface of the heater.
3. The heater must not be located near doorways or in other areas where drafts may affect the operation of the pilot or burner assembly.
4. DO NOT INSTALL THE HEATER BENEATH CURTAINS OR DRAPES.

To comply with the Z21.11.2 standard of the American National Standards Institute, none of the heaters described by this manual may be installed in a bathroom and the IRVF2T is the only model that may be installed in a bedroom. If an infrared heater is installed in a bedroom, it must be wall mounted. Floor stand mounted heaters are prohibited in bedrooms.

FLOOR PROTECTION

Some Flooring materials will discolor or otherwise deteriorate due to the temperature underneath the heater. Therefore, when the heater is installed freestanding with a floor stand in place on carpet, tile, linoleum or any combustible material other than wood flooring, the heater must be installed with a wood panel, metal panel or stoveboard extending at least the full width and depth of the floor stand. See Figure 2.

GAS PIPING AND GAS PRESSURE REQUIREMENTS

All gas piping must be installed to comply with local codes or, in the absence of local codes, with the latest edition of the National Fuel Gas Code ANSI Z223.1/NFPA 54. Do not use flexible hose unless the hose is listed by a recognized testing agency for use with gas and is approved by the local code authority. Unions in gas lines shall be of the ground joint type. Compounds used on threaded joints of gas piping must be resistant to the action of liquefied petroleum gas.

Gas piping must be of sufficient size to provide a minimum natural gas pressure at the appliance of 7 inches water column or 11 inches for LP gases. The maximum inlet gas pressure to the heater must not exceed 10.5 inches for natural gas and 13 inches for LP gases. If this heater is to be supplied with LP gas (bottled propane or butane) the tank or bottle supplying the gas must have a regulator that reduces the gas pressure to between 11 and 13 inches water column. The control will not operate with gas line pressure directly from the tank and may leak gas due to this excessive pressure.

Include a manual shutoff valve and union in the gas line so the heater may be disconnected for servicing. Include a sediment trap and a plugged 1/8-inch N.P.T. tap in the gas line also. The tap must be accessible for a test gauge connection and should be located somewhere between the manual shutoff valve and the heater's 3/8-inch N.P.T. inlet fitting. See Figures 2 and 3.

The heater may be mounted on a wall or installed freestanding on an optional floor stand.

A typical gas piping diagram for a freestanding heater installed on a floor stand is shown by Figure 2.

A typical gas piping diagram for a wall mounted heater is shown by Figure 3.

Use a soap-water solution or a liquid gas leak detector to coat each joint in the gas line and look for bubbles which indicate gas leaks. Never use an open flame when checking for leaks.

Gaseous fuels are highly explosive in certain concentrations and are very flammable. Any gas leaks in the plumbing supplying gas to this heater can lead to fire or explosion. **REPAIR ALL GAS LEAKS. ALL GAS LEAKS SHOULD BE REPAIRED BY A CERTIFIED INSTALLER.**

All gas piping must be installed to comply with local codes or, in the absence of local codes, with the latest edition of the National Fuel Gas Code ANSI Z223.1/NFPA 54. If flexible hose is used, it must be listed by a recognized testing agency.

Danger: Operation of this heater on LP gas without an approved regulator at the supply container will lead to gas leaks at the control with possible fire or explosion.

Caution: The heater and its individual shutoff valve must be disconnected from the gas supply piping system during any pressure testing of that system at test pressures in excess of ° PSIG. The heater must be isolated from the gas supply piping system by closing its individual manual shutoff valve during any pressure testing of the gas supply piping system at test pressures equal to or less than ° PSIG. Pressures in excess of ° PSIG will cause damage to the control valve and may cause damage to the shutoff valve.

Danger: Do not use candles, matches or other ignition sources when checking for leaks. Fuel gases are very flammable and, in certain concentrations, explosive. Checking for leaks with an open flame may lead to fire or explosion.

GAS PIPING AND GAS PRESSURE REQUIREMENTS

FIGURE 2

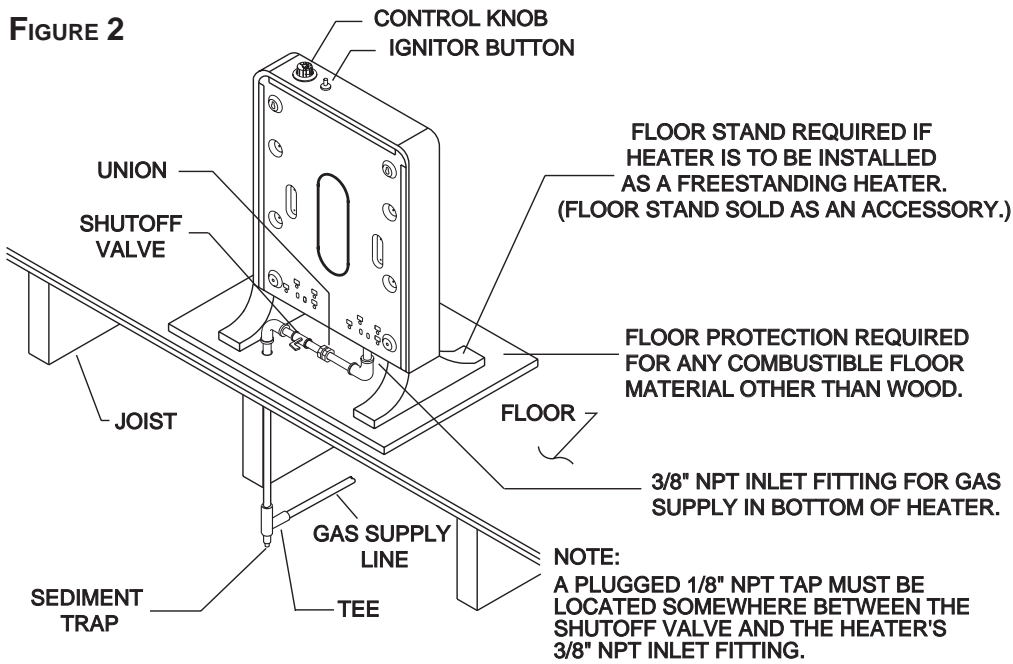
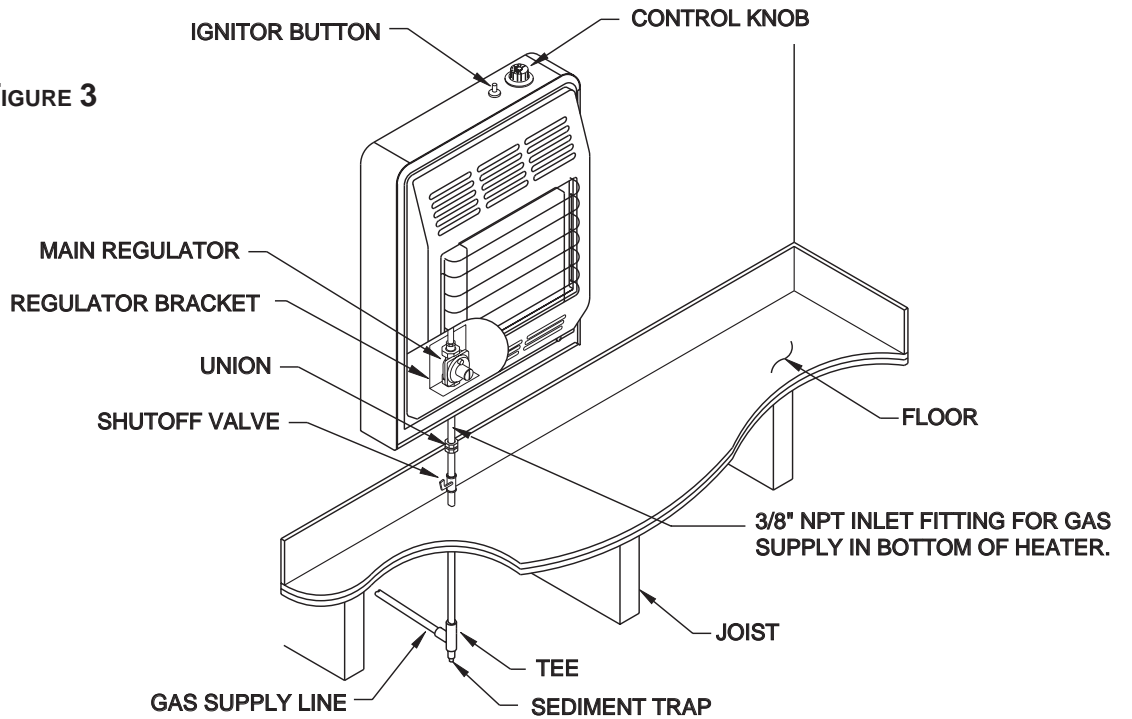

FIGURE 3



NOTE:
A PLUGGED 1/8" NPT TAP MUST BE LOCATED SOMEWHERE BETWEEN THE SHUTOFF VALVE AND THE HEATER'S 3/8" NPT INLET FITTING.

COMBUSTION AND VENTILATION AIR REQUIREMENTS

This heater requires fresh air (oxygen) for proper combustion and ventilation. In some cases, but not all, normal air infiltration into a building will supply a sufficient amount of fresh air for proper combustion and ventilation. The number of gas-fired appliances involved, the type of space being utilized, and the construction tightness of the building involved must all be considered when determining whether normal air infiltration is sufficient or if additional fresh air will be needed for proper combustion and ventilation of the gas-fired appliances installed in a particular space.

Unconfined space and confined space are the terms used to describe the space in which gas-fired appliances may be installed. The National Fuel Gas Code, ANSI Z223.1/NFPA 54 defines a *confined space* as a space whose volume is less than 50 cubic feet per 1,000 Btu per hour (4.8m³ per kW) of the aggregate input rating of all gas-fired appliances installed in that space, and an *unconfined space* as a space whose volume is not less than 50 cubic feet per 1,000 Btu per hour (4.8m³ per kW) of the aggregate input rating of all gas-fired appliances installed in that space. Rooms communicating directly with the space in which the appliances are installed, through openings not furnished with doors, are considered a part of the to-be-defined space. For example, three rooms in a house are adjoining with interconnecting passageways but no doors; each room has an 8 foot ceiling. One room is 16 x 12 feet, one is 12 x 12 feet, and one is 10 x 14 feet. The total volume of the three rooms is 3,808 cubic feet; (8 x 16 x 12) plus (8 x 12 x 12) plus (8 x 10 x 14) equals 3,808 cubic feet. To be considered an unconfined space in this example, the total maximum aggregate input rating of all gas-fired appliances installed in the 3,808 cubic feet space must not exceed 76,160 Btu per hour; (3,808 divided by 50) x 1,000 equals 76,160 Btu per hour.

Normal air infiltration into an unconfined space will be adequate to supply the necessary fresh air for proper combustion and ventilation if the building is not constructed unusually tight. However, if the building is of unusually tight construction, additional fresh air from outside will be required for proper combustion and ventilation of the gas-fired appliances installed in the unconfined space. Unusually tight construction is defined as construction where:

- a.) Walls and ceiling exposed to the outside atmosphere have a continuous water vapor retarder with a rating of 1 perm (6 x 10⁻¹¹ kg per pa-sec-m²) or less with openings gasketed or sealed, and
- b.) Weather stripping has been added on openable windows and doors, and
- c.) Caulking or sealants are applied to areas such as joints around window and door frames, between sole plates and floors, between wall-ceiling joints, between wall panels, at penetrations for plumbing, electrical, and gas lines, and at other openings.

Warning: If the area in which this appliance may be operated is smaller than that defined as an unconfined space or if the building is of unusually tight construction, provide adequate combustion and ventilation air by one of the methods described in the National Fuel Gas Code, ANSI Z223.1/NFPA 54, Latest Edition, Section 5.3 or applicable local codes. This appliance shall not be installed in a confined space or unusually tight construction unless provisions are provided for adequate combustion and ventilation air.

Caution: Because water is a product of fuel gas combustion, all gas-fired appliances will produce some water vapor (humidity) when fired. The water vapor may collect on windows and walls, especially in buildings constructed unusually tight. Providing additional fresh air will reduce the amount of water vapor which collects on the windows and walls.

COMBUSTION AND VENTILATION AIR REQUIREMENTS

Warning: The ODS (Oxygen Depletion Sensor) Pilot safety system is not a substitute for proper installation and use of this appliance. Failure to observe installation and use guidelines in this manual can lead to carbon monoxide poisoning, fire or explosion.

Consult your local building inspector or section 5.3 in the latest edition of National Fuel Gas Code ANSI Z223.1/NFPA 54 if you have any questions about fresh air requirements for proper combustion and ventilation of gas-fired appliances.

This heater is equipped with an ODS (oxygen depletion sensor) pilot safety system that turns off the heater if insufficient fresh air is available. Never attempt to adjust this safety system. It will not operate correctly if tampered with. When used without adequate fresh air, the heater may give off carbon monoxide, an odorless, poisonous gas.

If this heater shuts off during operation, do not relight it until you provide additional fresh air. If permanent provisions for providing additional fresh air have not been implemented, the additional fresh air may be provided by opening a window an inch or two while the appliance is operating. If the heater keeps shutting off during operation, have it serviced.

INSTALLATION AND ADJUSTMENT

Use these instructions as a guide while installing and adjusting the heater. The installation must conform with local codes or, in the absence of local codes, with the latest edition of the National Fuel Gas Code ANSI Z223.1/ NFPA 54.

If your heater is to be installed as a wall mounted heater begin with Step 1. If your heater is to be installed as a freestanding heater, begin with Step 10.

OPTIONAL BLOWERS

A model XAB thermostatically controlled, or model XMB manually controlled, blower may be installed on the IRVF3T and IRVF5T heaters. (IRVF2T models are not designed for use with optional blowers.) These blowers are the only blowers acceptable for use on these heaters. The use of any other blower could adversely and dangerously affect the operation of these heaters. The blower should be installed on the heater before the heater is installed. Check with your dealer for additional information and to purchase an optional blower.

WALL MOUNTED HEATER

1. Locate the wall-mount template and bag of fasteners provided with the heater.
2. Tape the wall-mount template to the wall surface where the heater is to be located. Template locator points should be level. Figure 4.

FIGURE 4

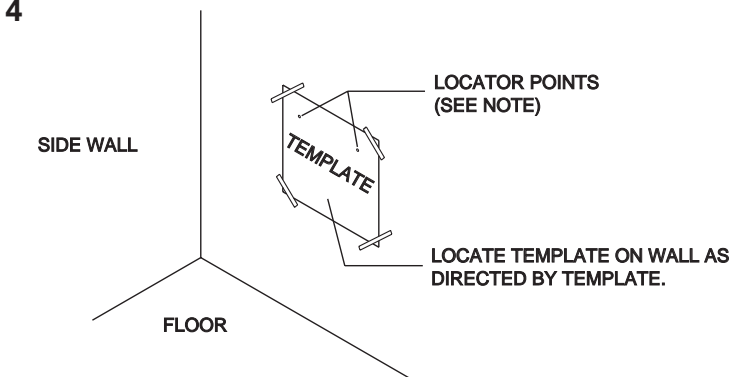

NOTE: DO NOT LOCATE WALL-MOUNT TEMPLATE WHERE LOCATOR POINTS ON TEMPLATE WILL ALIGN WITH STUDS IN WALL.

3. Check minimum clearances to combustible materials as directed by the wall-mount template. Refer to Figure 1 for additional information.

Use these instructions as a guide while installing and adjusting the heater. The installation must conform with local codes or, in the absence of local codes, with the latest edition of the National Fuel Gas Code ANSI Z223.1/ NFPA 54.

INSTALLATION AND ADJUSTMENT

Danger: Excessive torque (twisting) on the inlet fitting of this heater may cause gas leaks at one or more of the fittings inside the heater.

4. Mark locator points on wall; remove template and drive wall-mount anchors through the locator points and into the wall as shown by Figure 5.

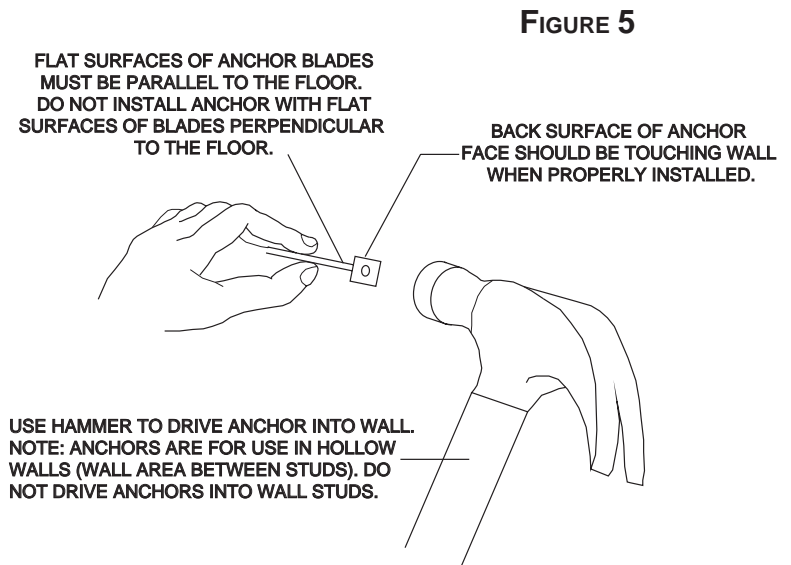

5. Insert mounting screws into anchors and turn each screw until back of screw head is touching front face of anchor, then back each screw out of its anchor 1/16 inch.
6. Remove the two front panel screws and then remove the front panel from the heater by pulling the lower portion of the front panel up and away as shown by Figure 6.

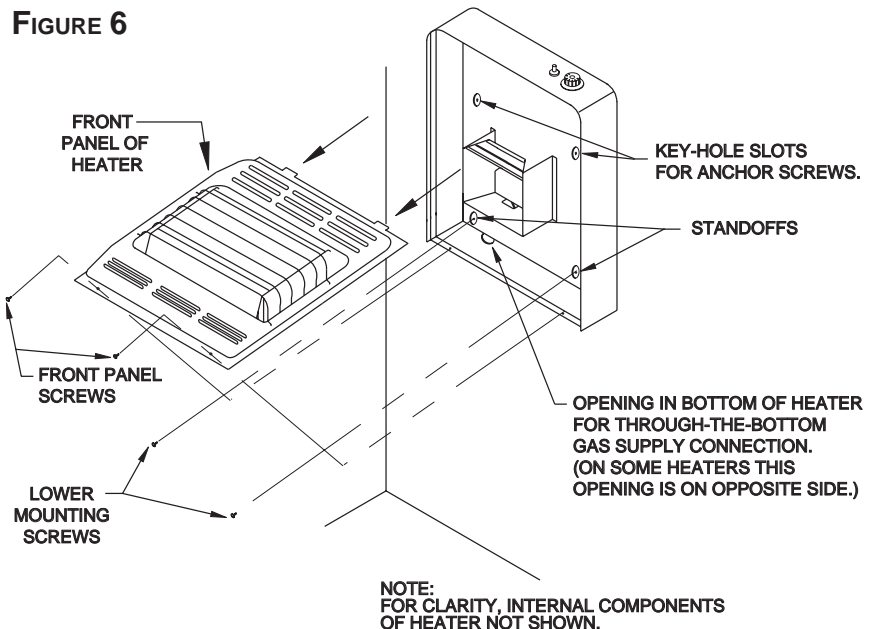

INSTALLATION AND ADJUSTMENT

7. If the heater is to be equipped with an optional blower, install the blower according to the instructions provided with the blower. (Note: IRVF2T heaters cannot be equipped with a blower.)
8. Locate the two key-hole slots on the back of the heater. Align the large openings of the key-hole slots with the mounting screws in the anchors in the wall. Hang the heater on the two mounting screws by positioning the heater so that the heads of the mounting screws protrude into the large openings of the key-hole slots; let the heater slide downward until the mounting-screw shanks are in the small openings of the key-hole slots. Tighten the two upper mounting screws into the wall anchors. See Figure 6.
9. Locate the two standoffs on back of the heater. Insert two screws from the bag of fasteners through the holes in the standoffs. Tighten the screws into the wall until the heater is firmly secured to the wall. See Figure 6.

Proceed to Step 14.

FREESTANDING HEATER INSTALLED ON A FLOOR STAND

10. Attach the proper floor stand according to the instructions provided with it. Model XFS Floor Stand is available from your local dealer.
11. Select a location which will maintain the minimum clearances from the heater to combustible materials.
12. Remove the two front panel screws shown by Figure 6 and then remove the front panel from the heater by pulling the lower portion of the front panel up and away as shown by Figure 6.
13. If the heater is to be equipped with an optional blower, install the blower according to the instructions provided with the blower. (Note: IRVF2T heaters cannot be equipped with a blower.)
14. Install proper gas piping according the "GAS PIPING AND GAS PRESSURE REQUIREMENTS" section of this manual.
15. Turn the heater's control knob clockwise to "Off". Figures 2 and 3.
16. Turn the gas on at the shutoff valve. Use a soap-water solution or liquid gas leak detector to check carefully for gas leaks at all fittings from the shutoff valve to the heater's control valve located at the top of the heater. If any leaks are found, turn the shutoff valve off and repair all leaks before proceeding.

Danger: Excessive torque (twisting) on the inlet fitting of this heater may cause gas leaks at one or more of the fittings inside the heater.

Danger: Do not use candles, matches or other ignition sources when checking for gas leaks. Fuel gases are very flammable and, in certain concentrations, explosive. Checking for leaks with an open flame may lead to fire or explosion which could cause personal injury, property damage, or death.

WALL MOUNT AND FREESTANDING INSTALLATION

17. Carefully read the entire "LIGHTING AND OPERATING HEATER" section of this manual, then light the heater's pilot according to the instructions. The pilot flame should be blue and should appear as indicated by Figure 7. See the "MAINTENANCE" section of this manual for additional information about the pilot.

FIGURE 7

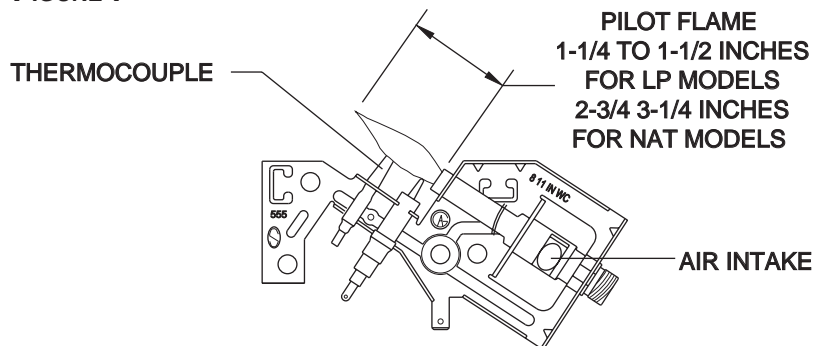

NOTE: NEVER ATTEMPT TO ADJUST THE PILOT IN ANY WAY, TO DO SO WILL CAUSE IT NOT TO OPERATE AS IT IS INTENDED.

Note: If the control knob still does not function properly after the control's mounting bracket has been adjusted as described, the wall is probably too bowed or uneven. Refer to the TROUBLESHOOTING section of this manual for more information.

Danger: Do not use candles, matches or other ignition sources when checking for gas leaks. Fuel gases are very flammable and, in certain concentrations, explosive. Checking for leaks with an open flame may lead to fire or explosion which could cause personal injury, property damage, or death.

Caution: If the wall on which the heater is mounted is bowed or uneven in the vicinity of the heater, the heater's cabinet might be in a bind which may not allow the heater's control knob to move up and down freely enough to function as described by the heater's lighting instructions. If the control knob will not depress and spring back into position freely due to a bowed or uneven wall, do the following: Turn the gas off at the shutoff valve. Loosen the four screws which secure the control's mounting bracket (Item No. 23 of "PARTS DIAGRAM" - found in the upper righthand corner of the heater. Slide the loosened mounting bracket either right or left until the control knob will depress and spring back into position freely. Leave the bracket at that location and retighten the screws. Recheck for gas leaks as directed. Relight the heater's pilot, and proceed to Step 19.

18. Immediately after the heater's pilot is lit, use a soap-water solution or a liquid gas leak detector to check each joint in the heater's pilot tubing for gas leaks. If any leaks are found, turn shutoff valve off and repair all leaks before proceeding.
19. After the pilot flame is established, turn the heater's control knob to "High". If the burner plaques do not light within four seconds, turn the control knob to "Pilot" and read the "TROUBLESHOOTING" section of this manual for help in determining what the problem may be.

INSTALLATION AND ADJUSTMENT

20. Immediately after the burner plaques light, use a soapy water solution or a liquid gas leak detector to check all burner tube joints for gas leaks. If any leaks are found, turn the shutoff valve off and repair all leaks before proceeding.

Note: During operation, the surface of each burner plaque will glow evenly as shown by Figure 8. Ceramic burner plaques operate with a slightly audible sound when operating correctly. If the burner plaques' flame does not appear correct or makes a loud roaring sound, turn the heater's control knob to "Off" and refer to the "TROUBLESHOOTING" section of this manual for probable cause and remedy.

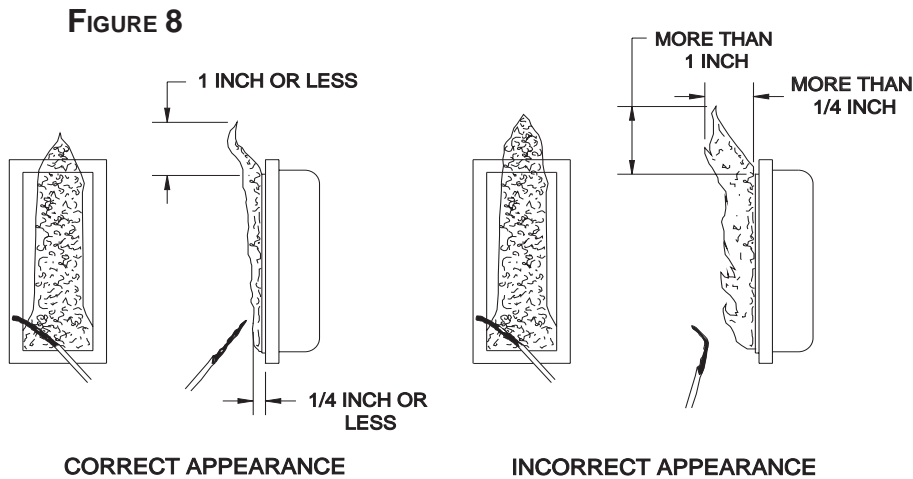

21. After all checks are satisfactorily completed as described above, turn the heater's control knob to "Pilot", and reinstall the heater's front panel. See Figure 6.
22. The heater may now be operated for desired heat. If no heat is desired, leave the control knob at the "Pilot" position or turn to "Off". For complete shutdown of the heater, turn the shutoff valve off and turn heater's control knob to "Off".

Danger: Do not use candles, matches or other ignition sources when checking for gas leaks. Fuel gases are very flammable and, in certain concentrations, explosive. Checking for leaks with an open flame may lead to fire or explosion which could cause personal injury, property damage, or death.

Important: Please refer to the "LIGHTING AND OPERATING HEATER" section of this manual for proper lighting instructions.

Notice: The heater will go through a curing process during its initial (first 2 to 3 hours) operating period and may emit some smoke and fumes (burning off oil, etc.). Be prepared for any smoke and fumes by raising windows or opening doors to provide additional ventilation during this initial operating period.

LIGHTING AND OPERATING HEATER

FOR YOUR SAFETY - READ BEFORE LIGHTING

WARNING: IF YOU DO NOT FOLLOW THESE INSTRUCTIONS EXACTLY, A FIRE OR EXPLOSION MAY RESULT CAUSING PROPERTY DAMAGE, PERSONAL INJURY OR LOSS OF LIFE.

- A. This appliance has a pilot which must be lighted by hand. When lighting the pilot, follow these instructions exactly.
- B. Before lighting smell all around the appliance area for gas. Be sure to smell next to the floor because some gas is heavier than air and will settle on the floor.

WHAT TO DO IF YOU SMELL GAS

- **DO NOT TRY TO LIGHT ANY APPLIANCE.**
 - **DO NOT TOUCH ANY ELECTRIC SWITCH; DO NOT USE ANY PHONE IN YOUR BUILDING.**
 - **IMMEDIATELY CALL YOUR GAS SUPPLIER FROM A NEIGHBOR'S PHONE. FOLLOW THE GAS SUPPLIER'S INSTRUCTIONS.**
 - **IF YOU CANNOT REACH YOUR GAS SUPPLIER, CALL THE FIRE DEPARTMENT.**
- C. Use only your hand to push in or turn the gas control knob. Never use tools. If the knob will not push in or turn by hand, don't try to repair it, call a qualified service technician. Force or attempted repair may result in a fire or explosion.
 - D. Do not use this appliance if any part has been under water. Immediately call a qualified service technician to inspect the appliance and to replace any part of the control system and any gas control which has been under water.

LIGHTING INSTRUCTIONS

READ THE PRECEDING SAFETY INFORMATION BEFORE LIGHTING THE HEATER.

INFORMATION ABOVE ON THIS PAGE.

Turn the knob to off. As you turn the knob between Pilot and Off you will hear a click. This indicates a safety lockout has been activated that will prevent you from turning the control knob back toward the LO position. Wait until the lockout is deactivated before attempting to turn the knob. **WARNING: Applying force while the lockout feature is activated will damage the control.**

Check for gas. If you smell gas, STOP! Follow "B" in the instructions. If you don't smell gas, go to the next step.

Turn the control knob counterclockwise (↶) until it stops at the Pilot position. (The ignitor button is not directly in front of the heater, but where the pilot is clearly in view, then push the control knob down, immediately depress the ignitor button until a loud click is heard. If the pilot does not light, try the ignitor at five second intervals for a maximum of ten times. If the pilot does not light, try lighting with a match, on the next page of this manual.)

Hold the control knob down for a minute and then release it. The control knob should pop back up and remain lit. If the control knob does not pop up when released, stop and immediately call your service technician or gas supplier. If the control knob does not pop up after several tries, turn the gas control knob clockwise (↷) to "OFF" and call your service technician.

When the pilot is lit, slowly turn the control knob counterclockwise (↶) past LO toward HI until the burners cycle off before the room has reached the desired temperature, turn the knob toward HI. When the burners burn before cycling off is sufficient to keep the room at the desired temperature, the control knob may be turned to Pilot or OFF.

TURNING THE APPLIANCE TO THE APPLIANCE

Turn the control knob clockwise (↷) to OFF. The knob will click between pilot and OFF.

Turn the control knob clockwise (↷) to OFF and turn the shutoff valve off. (See Figures 2 & 3)

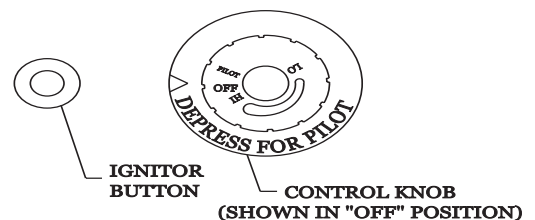



ALTERNATE METHOD OF LIGHTING THE PILOT WITH A MATCH

Follow the steps as if you were going to light the pilot with the push button ignitor up to the point of pushing down on the control knob to initiate the flow of gas to the pilot.

Then:

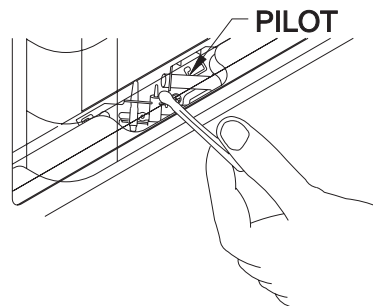
1. Position yourself where you are not directly in front of the heater and will be able to simultaneously reach the pilot with a burning match and push down on the control knob. (To reach the pilot easier, use a long fire place style match.)
2. Place a burning match at the end of the pilot barrel as shown below and push the control knob down fully.



3. After the pilot is lit, continue to hold the control knob down for a minute and then release it. The control knob should pop back up fully and the pilot should remain lit.
 - If the control knob does not pop up when released, stop and immediately call your service technician or gas supplier.
 - If the pilot will not stay lit after several tries, turn the gas control knob clockwise  to "OFF" and call your service technician or gas supplier.
4. Return to Step 7 of the Lighting Instructions on the previous page of this manual.

TO TURN OFF THE HEATER - Turn the control knob clockwise  to OFF. The knob will click between Pilot and OFF.

FOR COMPLETE SHUTDOWN OF THE HEATER - Turn the control knob clockwise  to OFF and turn the shutoff valve off. (See Figures 2 & 3.)

SAFETY CHECKLIST

Continued safe operation of this heater requires, but is not limited to, these “Do’s” and “Don’ts”:

DO’S:

1. Do make the installation according to local codes or, in the absence of local codes, with latest edition of the National Fuel Gas Code ANSI Z223.1/NFPA 54.
2. Do provide ample fresh air when using heater.
3. Do use only soap-water solution or a liquid gas leak detector when checking for leaks.
4. Do operate the heater only with the factory-installed dress guard in place.
5. Do keep clothing, furniture, draperies and other flammable materials away from the heater.
6. Do inspect the heater periodically and clean it as necessary.
7. Do keep the area around the heater clear and free from combustible materials, gasoline and other flammable liquids.
9. Do take the necessary precautions during any pressure testing of the heater’s gas supply piping system.
10. Do keep children and mentally impaired persons away from the heater.

DON'TS:

1. Don’t use candles, matches or any source of ignition when checking for leaks.
2. Don’t operate the heater without the dress guard in place.
3. Don’t place any combustible material near the heater.
4. Don’t allow lint and dust to accumulate around the heater.
5. Don’t close any openings in the heater cabinet or alter the cabinet in any way.
6. Don’t use or store gasoline or any flammable or explosive material in the area heated by this heater.
7. Don’t attempt to adjust the pilot flame.
8. Don’t block or alter air flow into and away from the heater (other than installing an optional blower).
9. Don’t allow children to play near or with the heater.

MAINTENANCE

To avoid electrical shock, turn off all electrical power to the heater if service is to be performed on a heater that is equipped with an optional blower.

It is necessary to KEEP BURNER AND CONTROL COMPARTMENT CLEAN. In even the cleanest homes, lint and dust carried by air moving through the heater will collect on parts of the heater. If allowed to become excessive, this lint and dust will plug the air intakes of the burner and pilot. Excessive buildup at the burner intakes can cause improper combustion of the gas with the production of carbon monoxide. Excessive lint and dust buildup around the burner can become a fire hazard. The following maintenance program should be followed monthly or more often in areas where dust or lint accumulated rapidly.

1. Turn the gas off at the shutoff valve in the gas line and allow the heater to cool.
2. Remove the heater's front panel.
3. Use care to avoid striking the gas lines and carefully vacuum all dust and lint from the burner intakes, pilot and inside the cabinet. If any gas lines are struck, carefully check each joint for leaks as defined in the "INSTALLATION AND ADJUSTMENT" section of this manual.
4. Replace the heater's front panel.
5. Light the pilot and operate the heater according to instructions.

NEVER OPERATE THIS HEATER WITHOUT THE FACTORY-INSTALLED DRESS GUARD IN PLACE. ANY SAFETY SCREEN OR GUARD REMOVED FOR SERVICING AN APPLIANCE MUST BE REPLACED PRIOR TO OPERATING THE APPLIANCE.

The pilot gas flow is not adjustable on this heater. Proper operation of the ODS (Oxygen Depletion Sensitive) Pilot Safety System is dependent upon the pilot gas flow rate and any attempt to adjust this rate could cause the ODS System to not operate correctly. It is very important that the pilot be kept clean and free of lint and dust. Should the pilot flame show a yellow tip, clean the air intake in the pilot burner (see Figure 7). The pilot orifice spud is not replaceable for this pilot. Should it become plugged, clean it only with forced air. **NEVER FORCE A DRILL, WIRE OR ANY OBJECT INTO THE PILOT ORIFICE.** Any increase in the orifice size will cause the ODS System to not work as it should.

Each year, before the heater is used, the entire heater and control system should be inspected by a qualified service person. Any service which requires disconnecting the gas supply line must be performed by a qualified service person. If the heater is moved, even slightly, for any reason, the gas supply lines must be rechecked for leaks immediately with a soap-water solution or a liquid gas leak detector. If leaks are found, turn the gas off at the shutoff valve until all leaks are corrected. **DO NOT ATTEMPT TO SUBSTITUTE CONTROL SYSTEM COMPONENTS OF ANY TYPE OTHER THAN ORIGINALLY SUPPLIED WITH THIS HEATER.** Substituted components will cause the heater's pilot safety system to not operate as intended.

Do not use this room heater if any part has been under water. Immediately call a qualified service technician to inspect the room heater and to replace any part of the control system and any gas control which has been under water.

TROUBLESHOOTING

Due to high temperatures, this appliance must be located out of traffic and away from furniture and draperies. Children and adults should be alerted to the hazard of high surface temperature and should be kept away to avoid burns or clothing ignition. Children should be carefully supervised when in the same room with the appliance.

Any safety screen or guard removed for servicing an appliance must be replaced prior to operating the appliance.

Do not place clothing or other flammable material on or near the appliance. Installation and repair must be performed by a qualified service person. The appliance should be inspected before use and at least annually by a professional service person. More frequent cleanings may be required due to excessive lint from some carpeting, bedding material, etc. It is imperative that control compartments, burners and circulating air passageways of the appliance be kept clean. Refer to "MAINTENANCE" section of this manual.

The manufacturer has made every reasonable effort to insure that this heater operates properly and satisfactorily, but sometimes problems arise. The troubleshooting chart below lists several problems with their probable cause and solution. Any adjustments and/or replacements must be performed by a qualified person. Do not replace any component with a different type. Only use components supplied by the manufacturer of this heater.

Problem	Cause	Solution
Flame too large.	Pressure regulator at gas supply set too high.	Reset, using manometer.
	Defective regulator on heater.	Replace.
	Heater's burner orifice(s) too large.	Replace with correct size.
Yellow tip flame.	Clogged burner ports.	Clean ports
	Misaligned orifice(s).	Realign orifice(s) or replace burner tubing.
Floating flame.	Insufficient primary air.	Clean burner's air intake area.
Delayed ignition.	Burner ports clogged.	Clean ports.
	Low pressure.	Adjust pressure regulator at gas supply.
Pilot burner won't ignite.	Main gas OFF.	Open manual valve.
	Defective control valve.	Replace.
Pilot goes out during burner operation.	Oxygen depletion.	Provide fresh air, open window.
	Defective thermocouple.	Replace.
	Heater in drafty location.	Stop drafts.
	Pilot dirty.	Clean pilot.
	Insufficient inlet pressure.	Increase inlet pressure to minimum level specified in "GAS PIPING AND PRESSURE REQUIREMENTS" section of this manual.
Control knob binds. Won't pop up properly.	Heater mounted to bowed or uneven wall.	Adjust controls mounting bracket as directed in the "INSTALLATION AND ADJUSTMENT" section of manual.
	Defective control.	Replace the control.

WARRANTY

LIMITED WARRANTY

WHAT IS COVERED AND FOR HOW LONG

Monessen Hearth Systems warrants this product to be free from defects in material or workmanship for 5 years from date of purchase, provided the product has been installed, operated, and maintained in accordance with applicable instructions. This warranty covers only the cost of parts and a predetermined labor allowance to restore this heater to proper operating condition.

WHAT IS NOT COVERED

- Service call to diagnose trouble.
- Painted surfaces.
- Damage or defect caused by improper installation, accident, misuse, abuse or alteration.

LIMITATIONS AND EXCLUSIONS

1. No one has authority to add to or vary this limited warranty, or to create for Monessen Hearth Systems any other obligation or liability in connection with this heater.
2. Any implied warranty applicable to this heater is limited in duration to the same period of time as this written warranty. Some states do not allow limitations on how long an implied warranty lasts, so the above limitations may not apply to you.
3. Monessen Hearth Systems shall not be liable for incidental, consequential, special, or contingent damages you might suffer as a result of its breach of this written warranty or any implied warranty. Some states do not allow the exclusion or limitation of incidental or consequential damages, so the above limitation or exclusion may not apply to you.
4. This warranty applies only to the original purchaser and may not be transferred.
5. This warranty applies only to a gas heater used as a residential appliance.
6. If you cannot verify the purchase date of the heater, the warranty period will begin on the date the heater was manufactured.
7. Replacement or repair parts are warranted for the remaining period of the original part warranty. Warranty parts must be obtained through authorized dealers of this product and/or Monessen Hearth Systems who will provide original factory replacement parts. Failure to use original factory replacement parts voids this warranty.

YOUR DUTIES

1. This heater must be installed by a qualified installer, and operated and maintained in accordance with all applicable codes and the instructions furnished with the heater.
2. You must provide an invoice, cancelled check, or payment record to verify the purchase date of the heater when making a warranty claim.

IF YOU HAVE A PROBLEM WITH YOUR HEATER

Call or write Monessen Hearth Systems, Technical Service Department at the address or telephone number listed below. DO NOT take a heater needing repair, or believed to be defective back to the seller.

MONESSEN HEARTH SYSTEMS
2813 W. MALL DRIVE, UNIT B
FLORENCE, ALABAMA 35630
TELEPHONE: 1-866-500-5671
WWW.MONESSENHEARTH.COM

This warranty gives you specific legal rights, and you may also have other rights which vary from state to state.

ATTENTION

**APPLIANCE
INSTALLER:**

**PLEASE RETURN THESE OPERATING
AND INSTALLATION INSTRUCTIONS
TO THE APPLIANCE FOR
CONSUMER USE.**