

This Owner's Manual is provided and hosted by [Appliance Factory Parts](#).



Monessen Hearth YS18PV Owner's Manual

[Shop genuine replacement parts for Monessen Hearth
YS18PV](#)



[Find Your Monessen Hearth Fireplace Parts - Select From 701 Models](#)

----- Manual continues below part list -----

Available Replacement Parts for Monessen Hearth YS18PV

SRV00K0632	ASSY-WIRE
SRV14D0503	PIEZO IGNITER-snap in
SRV32D0232	SWITCH, ON/OFF+
SRV14D0468	VALVE MV LP (060620)+

UNVENTED GAS LOG HEATER OR VENTED DECORATIVE APPLIANCE INSTALLATION AND OPERATING INSTRUCTIONS

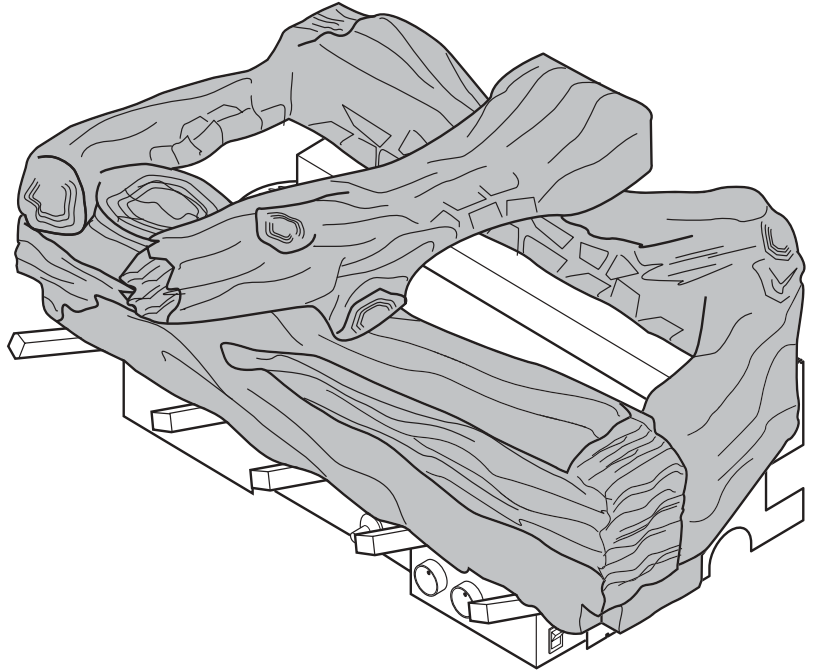

MODEL YS24/18

Natural Gas or Propane/LPG

Control Type: Manual or Milli-Volt



This is an unvented gas-fired heater. It uses air (oxygen) from the room in which it is installed. Provisions for adequate combustion and ventilation air must be provided. Refer to page 7.

WARNINGS

If the information in this manual is not followed exactly, a fire or explosion may result causing property damage, personal injury or loss of life.

- Do not store or use gasoline or other flammable vapors and liquids in the vicinity of this or any other appliance.
- **WHAT TO DO IF YOU SMELL GAS**
 - Do not try to light any appliance.
 - Do not touch any electrical switch; do not use any phone in your building.
 - Immediately call your gas supplier from a neighbor's phone. Follow the gas supplier's instructions.
 - If you cannot reach your gas supplier, call the fire department.
- Installation and service must be performed by a qualified installer, service agency or the gas supplier.

READ AND SAVE THESE INSTRUCTIONS

CONTENTS

IMPORTANT SAFETY INFORMATION	3
GETTING STARTED	5
PRODUCT FEATURES AND SPECIFICATIONS	6
GENERAL INSTALLATION INFORMATION	7
FIREPLACE AND HEARTH DIMENSIONS	9
PLACEMENT IN A FIREPLACE WITH A RESTRICTIVE BARRIER	10
CLEARANCES AND HEIGHT REQUIREMENTS	11
FLOOR CLEARANCE	14
FIREPLACE PREPARATION	15
INSTALLING VENTED APPLICATIONS	16
CONNECTING THE GAS	17
CHECKING GAS PRESSURE	18
ELECTRICAL WIRING (MILLI-VOLT)	19
LOG PLACEMENT	21
FLAME APPEARANCE	22
CHECKING THE BURNER FLAME	23
OPERATING INSTRUCTIONS	24
FOR YOUR SAFETY READ BEFORE LIGHTING	24
MANUAL CONTROL LIGHTING INSTRUCTIONS	25
MILLI-VOLT CONTROL LIGHTING INSTRUCTIONS	26
MATCH LIGHTING INSTRUCTIONS	27
CLEANING AND SERVICING	27
TROUBLESHOOTING	28
ILLUSTRATED PARTS BREAKDOWN	30
REPLACEMENT PARTS LIST	31
WARRANTY	BACK PAGE

IMPORTANT SAFETY INFORMATION

INSTALLER

Please leave these instructions with the owner.

OWNER

Please retain these instructions for future reference.

IMPORTANT

Read these instructions carefully before installing or trying to operate this vent-free gas heater.

WARNING

- Any change to this heater or its controls can be dangerous.
- Improper installation or use of the heater can cause serious injury or death from fire, burns, explosion or carbon monoxide poisoning.
- Do not allow fans to blow directly into the fireplace. Avoid drafts that alter burner flame patterns.
- Do not use a blower insert, heat exchanger insert or other accessory, not approved for use with this heater where applicable.

1. Due to high temperatures, the heater should be located out of traffic and away from furniture and draperies.
2. Children and adults should be alerted to the hazard of high surface temperature and should stay away to avoid burns or clothing ignition.
3. Young children should be carefully supervised when they are in the same room with the heater
4. Do not place clothing or other flammable material near the fireplace when the heater is in use.
5. Any safety screen or guard removed for servicing, must be replaced prior to operating the heater.
6. Installation and repair should be done by a qualified service person.
7. To prevent malfunction and/or sooting, an unvented gas heater should be cleaned at least annually by a professional service person. More frequent cleaning may be required due to excessive lint from carpeting, etc. It is imperative that control compartments, burners and circulating air passageways be kept clean.

8. **CARBON MONOXIDE POISONING:** Early signs of carbon monoxide poisoning are similar to the flu with headaches, dizziness and/or nausea. If you have these signs, obtain fresh air immediately. Have the heater serviced as it may not be operating properly.
9. The installation must conform with local codes or, in the absence of local codes, with the National Fuel Gas Code, ANSI Z223.1.

10. This unit complies with ANSI Z21.11.2b-1998 Unvented Heaters and also complies with ANSI Z21.60-1996 Decorative Vented Appliances for Solid Fuel Burning Fireplaces. State and local codes may only allow operation of this appliance in a vented configuration. Check your state or local codes. For vented operation, see “VENTED INSTRUCTIONS” in this manual.
11. Do not install the heaters in a bathroom or bedroom.
12. Correct installation of the ceramic fiber logs, proper location of the heater, and annual cleaning are necessary to avoid potential problems with sooting. Sooting, resulting from improper installation or operation, can settle on surfaces outside the fireplace. See log placement instructions for proper installation.
13. Avoid any drafts that alter burner flame patterns. Do not allow fans to blow directly into fireplace. Do not place a blower inside burn area of firebox. Ceiling fans may create drafts that alter burner flame patterns. Sooting and improper burning will occur.
14. **Caution:** Candles, incense, oil lamps, etc. produce combustion byproducts including soot. Vent-free appliances will not filter or clean soot produced by these types of products. In addition, the smoke and/or aromatics (scents) may be reburnt in the vent-free appliance which can produce odors. It is recommended to minimize the use of candles, incense, etc. while the vent-free appliance is in operation.
15. This is an unvented gas-fired heater. It uses air (oxygen) from the room in which it is installed. Provisions for adequate combustion and ventilation air must be provided. See page 7.

Continued on page 4

IMPORTANT SAFETY INFORMATION

Continued from page 3

16. Keep room area clear and free from combustible materials, gasoline and other flammable vapors and liquids.
17. Unvented gas heaters are a supplemental zone heater. They are not intended to be a primary heating appliance. Water vapor produced by an unvented heater can create moisture problems in a home when operated for extended periods of time.
18. During manufacturing, fabricating and shipping, various components of this appliance are treated with certain oils, films or bonding agents. These chemicals are not harmful but may produce annoying smoke and smells as they are burned off during the initial operation of the appliance; possibly causing headaches or eye or lung irritation. This is a normal and temporary occurrence.

The initial break-in operation should last two to three hours with the burner at the highest setting. Provide maximum ventilation by opening windows or doors to allow odors to dissipate. Any odors remaining after this initial break-in period will be slight and will disappear with continued use.
19. Input ratings are shown in BTU per hour and are for elevations up to 2,000 feet. For elevations above 2,000 feet, input ratings should be reduced 4 percent for each 1,000 feet above sea level. Refer to the National Fuel Gas Code.
20. The heater and its individual shutoff valve must be disconnected from the gas supply piping system during any pressure testing of that system at test pressures in excess of 1/2 psig (3.5 kPa).
21. The heater must be isolated from the gas supply piping system by closing its individual manual shutoff valve during any pressure testing of the gas supply piping system at test pressures equal to or less than 1/2 psig (3.5 kPa).
22. Do not use this room heater if any part has been under water. Immediately call a qualified service technician to inspect the room heater and to replace any part of the control system and any gas control which has been under water.
23. This appliance must not be used with glass doors in the closed position. This can lead to pilot outages and severe sooting outside the fireplace.

24. Never burn solid fuels in a fireplace where a unvented room heater is installed.
25. Always have a fireplace screen in place when the appliance is in operation and , unless other provisions for combustion air are provided, the screen shall have an opening(s) for induction of combustion air.

This appliance may be installed in an aftermarket, permanently located, manufactured (mobile) home, where not prohibited by local codes.

This appliance is only for use with the type of gas indicated on the rating plate. This appliance is not convertible for use with other gases.

MAKE SURE YOU HAVE RECEIVED ALL PARTS:

Check your packing list to verify that all listed parts have been received. You should have the following:

- Unvented gas log grate/burner assembly
- Plastic bag containing crushed volcanic rock
- Installation/operating instructions
- Two (2) anchoring screws
- Ceramic Fiber logs

The milli-volt controlled version of this heater is the only style designed to be operated with optional devices for ON/OFF functions. The following options may be used with the millivolt controlled heater. These options are not packaged with the log set.

- Hand held Remote with receiver
- Wall thermostat with 15' wire
- Wall switch with 15' wire
- Hand held Thermostat Remote with receiver

CAUTION

- **Handle the gas log burner assembly by the grate only. Do not pick the unit up by the burners.**
- **Gloves are recommended when handling ceramic fiber logs to prevent skin irritation from loose fibers. Logs are fragile — handle with care.**

Carefully inspect the contents for shipping damage. If any parts are missing or damaged, immediately inform the dealer from whom you purchased the appliance. **Do not attempt to install any part of the appliance unless you have all parts in good condition.**

WHAT YOU WILL NEED FOR INSTALLATION:

You must have the following items available before proceeding with installation:

- External regulator (for propane/LPG and 1/2 lb. natural gas systems only)
- Piping which complies with local codes
- Sediment trap
- Screwdriver
- Tee joint.
- Pipe sealant approved for use with propane/LPG (Resistant to sulfur compounds)
- Drill with 5/32 bit
- Pipe wrench or appropriate size crescent wrench set
- Manual shutoff valve

PRODUCT FEATURES AND SPECIFICATIONS

NATURAL GAS

Manual Pressure

Regulator Pressure Setting: 4.0" w.c.
 Gas Inlet Pressure: Max. 10 1/2" w.c.
 Min. 5" w.c.

Milli-Volt Pressure

Regulator Pressure Setting: 3.5" w.c.
 Pilot Regulator: 3.5" w.c.
 Gas Inlet Pressure: Max. 10 1/2" w. c.
 Min. 5" w.c.

Model Number	Control	Gas Rate	
		Max BTU/Hr	Min BTU/Hr
YS24/18NM	Manual	28,000	15,000
YS24/18NV	Milli-Volt	28,000	18,000

PROPANE/LPG

Note: An external regulator is required to reduce supply pressure to a maximum of 13" w.c.

Manual Pressure

Regulator Pressure Setting: 10" w.c.
 Gas Inlet Pressure: Maximum 13" w.c.
 Minimum 11" w.c.

Milli-Volt Pressure

Regulator Pressure Setting: 10" w.c.
 Gas Inlet Pressure: Maximum 13" w.c.
 Minimum 11" w.c.

Model Number	Control	Gas Rate	
		Max BTU/Hr	Min BTU/Hr
YS24/18PM	Manual	28,000	18,000
YS24/18PV	Milli-Volt	28,000	21,000

IGNITION CONTROLS

Piezo ignitor allows ignition of the pilot without the use of matches or batteries.

Manual control has three (3) positions:

- OFF** - All gas to the gas logs is shut off at the valve.
- IGN** - Valve position to light/maintain a standing pilot.
- HI/LOW** - Variable position corresponding to desired flame height (heat input)

Milli-Volt control has four (4) positions:

- OFF** - All gas to the gas logs is shut off at the valve.
- IGN** - Valve position to light/maintain a standing pilot.
- ON** - Valve position to turn ON/OFF log set with remote switch/thermostat.
- HI/LOW** - Variable position to control flame height (heat output).

PILOT

The gas log heater is fitted with a specially designed safety pilot light (ODS assembly) which senses the amount of oxygen available in the room and shuts the gas log heater off if the oxygen level begins to drop below a satisfactory level. The pilot can only be relit when adequate fresh air is available.

THERMAL GENERATOR

The milli-volt gas log pilot is fitted with a milli-volt generator to provide power for remote activation.

CODES

Adhere to all local codes or, in their absence, the latest edition of THE NATIONAL FUEL GAS CODE ANSI Z223.1 or NFPA54 which can be obtained from...

American National Standards Institute, Inc.

1430 Broadway
New York, NY 10018

or

National Fire Protection Association, Inc.

Batterymarch Park
Quincy, MA 02269

ADEQUATE COMBUSTION AND VENTILATION AIR

This heater shall not be installed in a confined space or unusually tight construction unless provisions are provided for adequate combustion and ventilation air.

The National Fuel Gas Code, (ANSI Z223.1), defines a confined space as a space whose volume is less than 50 cubic feet per 1,000 BTU per hour (4.8 m³ per kw) of the aggregate input rating of all appliances installed in that space. An unconfined space is defined as a space whose volume is not less than 50 cubic feet per 1,000 BTU per hour (4.8 m³ per kw) of the aggregate input rating of all appliances installed in that space. Rooms communicating directly with the space in which the appliances are installed, through openings not furnished with doors, are considered a part of the unconfined space.

UNUSUALLY TIGHT CONSTRUCTION IS DEFINED AS CONSTRUCTION WHERE...

- a) walls and ceilings exposed to the outside atmosphere have a continuous water vapor retarder with a rating of 1 perm (6 x 10¹¹ kg per-pa-sec-m²) or less with openings gasketed or sealed, and
- b) weather striping has been added on openable windows and doors, and
- c) caulking or sealant are applied to areas such as joints around windows and door frames; between sole plates and doors; between wall-ceiling joints; between wall panels; at penetrations for plumbing, electrical, and gas lines; and at other openings.

GENERAL INSTALLATION INFORMATION

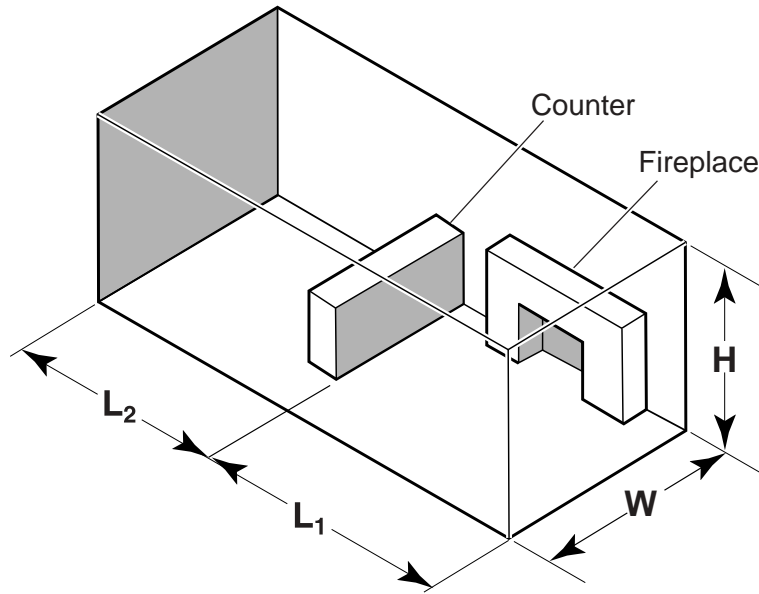

Figure 1 - Example of a Large Room with 1/2 Wall Divider

The following formula can be used to determine the maximum heater rating per the definition of unconfined space:

$$\frac{\text{BTU/Hr} = (L_1 + L_2) \text{ Ft} \times (W) \text{ Ft} \times (H) \text{ Ft}}{50} \times 1000$$

Consider two connecting rooms with an open area between, with the following dimensions:

$$L_1 = 15\frac{1}{2} \text{ Ft.}, L_2 = 12 \text{ Ft.}, W = 12 \text{ Ft.}, H = 8 \text{ Ft.}$$

$$\frac{\text{BTU/Hr} = (15\frac{1}{2} + 12) \times (12) \times (8)}{50} \times 1000 = 52800 \text{ BTU/Hr}$$

If there were a door between the two rooms the calculation would be based only on the room with the heater.

$$\frac{\text{BTU/Hr} = (15\frac{1}{2}) \times (12) \times (8)}{50} \times 1000 = 29760 \text{ BTU/Hr}$$

WARNING

If the area in which the heater may be operated is smaller than that defined as an unconfined space or if the building is of unusually tight construction, provide adequate combustion and ventilation air by one of the methods described in the National Fuel Gas Code, ANSI Z223.1, Section 5.3 or applicable local codes.

FIREPLACE AND HEARTH DIMENSIONS

WARNING

This appliance has been specifically tested and design certified for installation only in a solid-fuel burning fireplace including factory-built UL127 fireplaces and masonry fireplaces, or in a listed ventless firebox (*see below*).

Exception: DO NOT install this appliance in a factory-built fireplace that includes instructions stating that it has not been tested or should not be used with unvented gas logs.

Use manufacturer's installation and clearance requirements as defined in their manual.

The YS Series unvented room heater is approved for installation into the following unvented fireplaces:

GCUF Series Fireboxes 32, 36, or 42

The YS Series unvented room heater may also be installed into a Ventless Firebox Enclosure for Gas Fired Decorative Type Unvented Room Heaters per IAS Requirement No. 2-97 (typically referred to as a "Universal Firebox"), as long as firebox hearth dimensions meet the minimum hearth dimensions shown below.

Model	A	B	C	D
YS	18"	13"	27"	17"

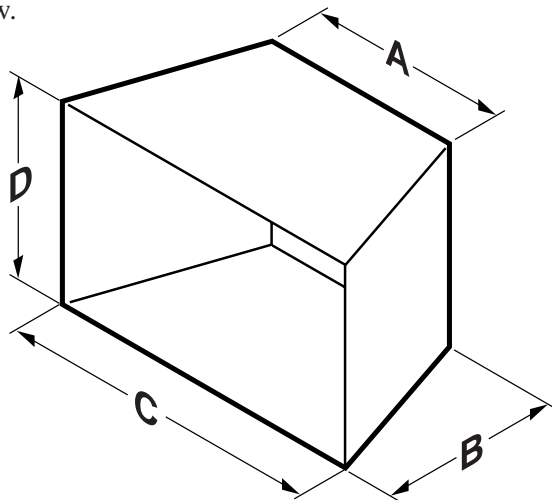

Figure 2 - Hearth Minimum Dimension for Solid Fuel Burning Fireplaces and UL127 Factory Built Fireplaces

PLACEMENT IN A FIREPLACE WITH A RESTRICTIVE BARRIER

IMPORTANT INFORMATION FOR THE INSTALLATION OF THIS GAS LOG SET

The following are guidelines for placing a gas log set in a fireplace that has a restrictive barrier along the bottom front opening of the fireplace. Some examples of barriers are glass/screen door frames and sunken/recessed fireplaces.

Height of Restriction (X)	Minimum Depth of Fireplace/Firebox
No restriction	13"
0 to 1.5"	16"
Greater than 1 1/2" to 3"	16"
Greater than 3:	ANY BARRIER GREATER THAN THREE INCHES (3") PLACED IN FRONT OF THE GAS LOG SET IS NOT RECOMMENDED BY THE MANUFACTURER.

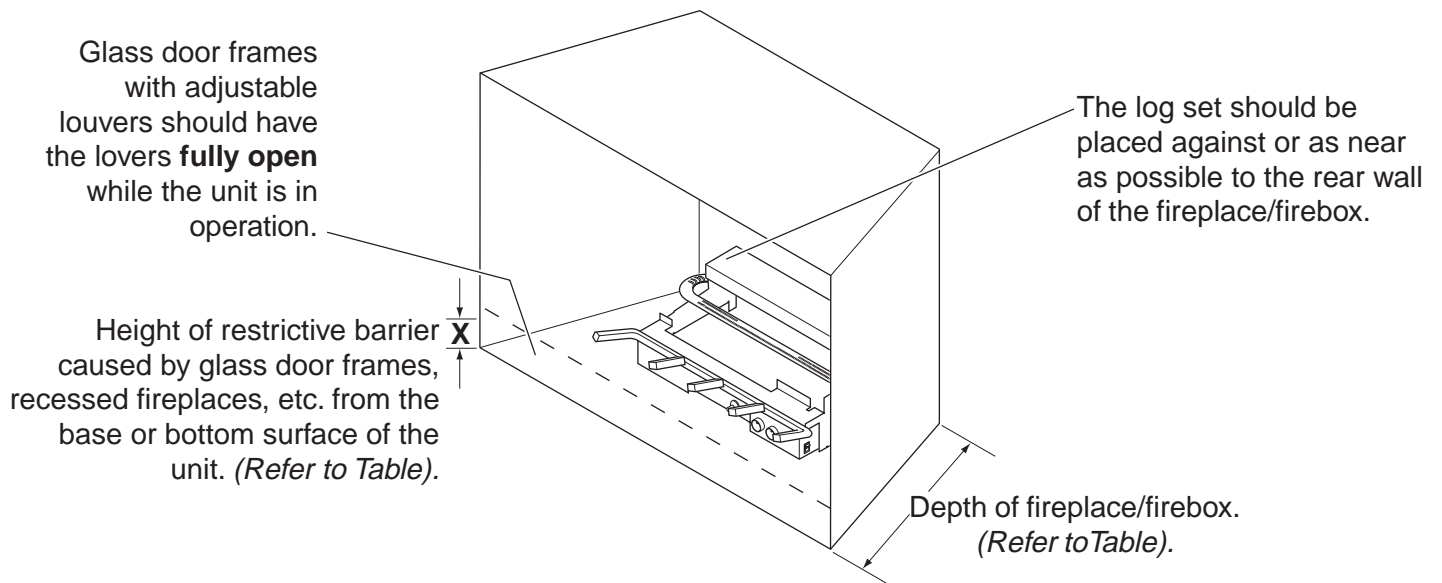

Figure 3 - Reference Drawing of a Natural Flame Log Set in an Enclosure

WARNING

Barriers such as the bottom of a glass door frame placed in front of a gas log set can change the air flow characteristics of the fireplace which in turn can cause the unit to overheat and malfunction.

NOTE: Non combustible material such as refractory brick may be used to line the floor of the fireplace in order to raise the height of the gas log set in relation to a restrictive barrier. If the unit is raised, the minimum height dimension listed in the homeowner's manual must not be exceeded.

NOTE: If the log set is equipped with a remote receiver, a restrictive barrier may reduce the battery life by increasing the ambient temperature inside the fireplace. Placement of the receiver outside of the fireplace will extend the battery life.

CLEARANCES AND HEIGHT REQUIREMENTS

WARNING

The dimensions shown in Figures 4 through 10 and defined in the fireplace manufacturer's instructions are *minimum clearances* to maintain when installing this heater. Left and right clearances are determined when facing the front of the heater.

When heater is installed into a ventless firebox, minimum clearances, as specified by the ventless firebox manufacturer, must be met.

Follow these instructions carefully to ensure safe installation. Failure to follow instructions exactly can create a fire hazard.

Sidewall and ceiling clearances: The *sides* of the fireplace opening must be *at least 16"* from any combustible wall. The *ceiling* must be *at least 42"* from the top of the fireplace opening.

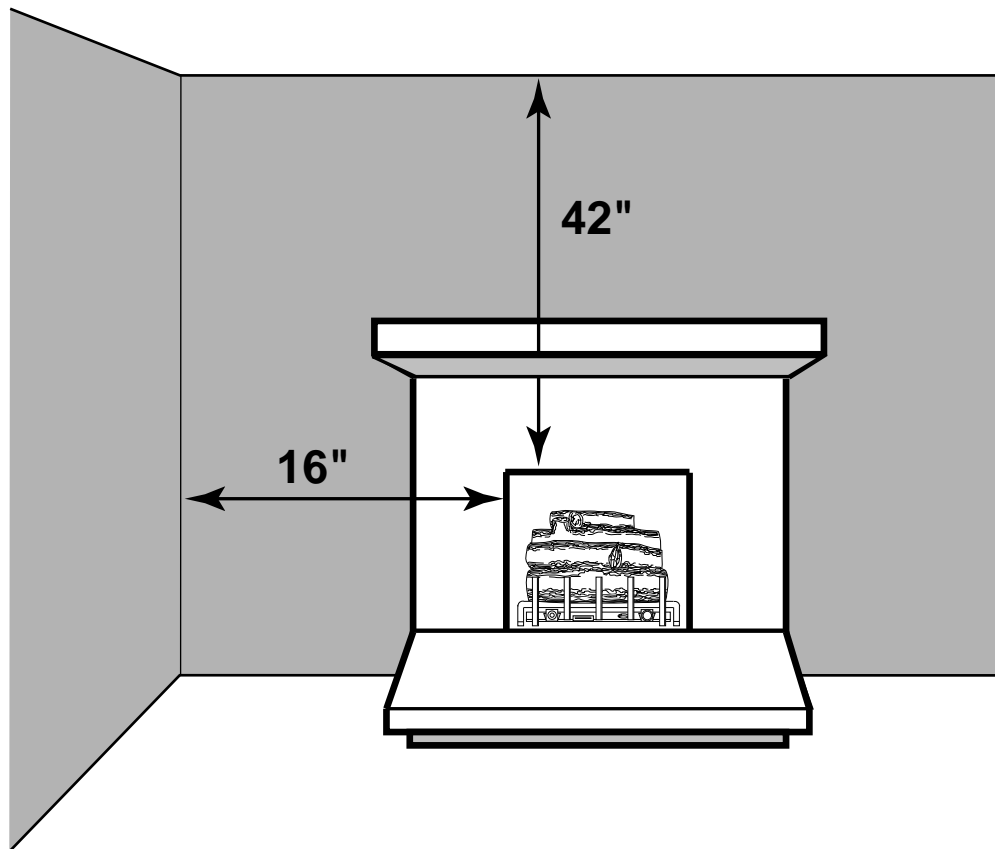

Figure 4 - Sidewall and Ceiling Clearances

CLEARANCES and HEIGHT REQUIREMENTS

Heat resistant material (minimum requirements) with no wooden mantel or other combustible projection:

To install the gas logs into a fireplace with no wooden mantel, shelf or other combustible projection above the fireplace opening, measure the heat resistant material height, *per Figure 5*, then refer to **TABLE A**.

Heat resistant materials such as slate and marble must be at least 1/2" thick. Sheet metal should not be installed onto combustible material.

IMPORTANT: If you cannot meet these minimum clearances you must operate the heater with chimney flue damper open. Refer to "INSTALLING VENTED APPLICATIONS" found on page 16.

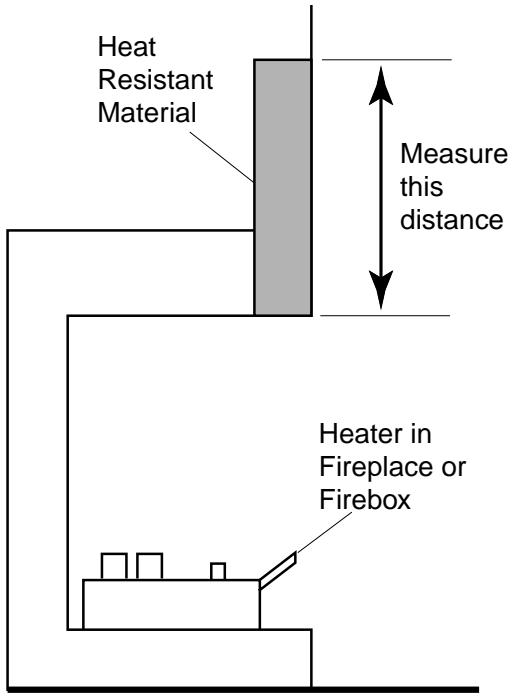

Figure 5 - Measuring Heat Resistant Material

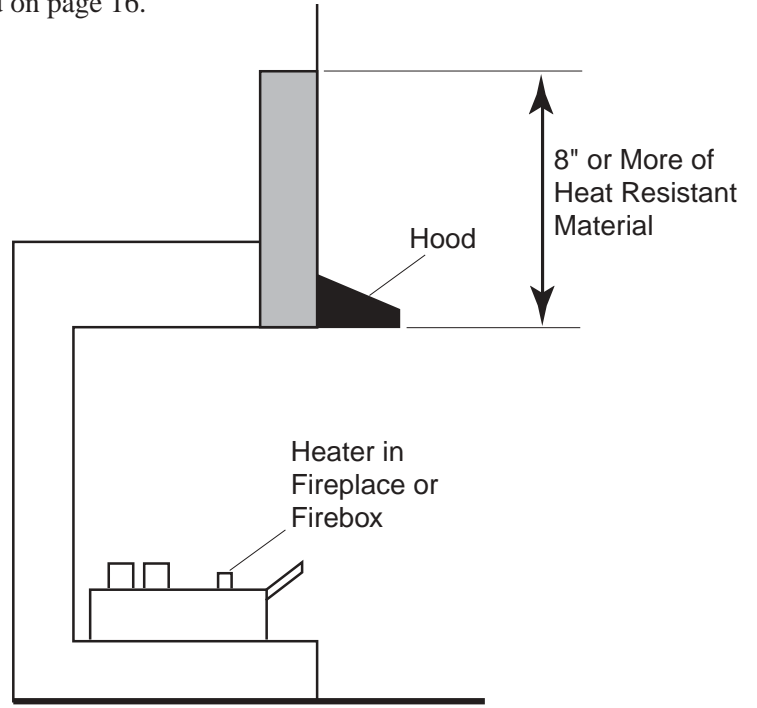

Figure 6 - Measuring Heat Resistant Material for Mantel

Heat resistant material (minimum requirements) with wooden mantel or other combustible projection:

To install the heater with a wooden mantel, shelf or other combustible projection above, first measure the heat resistant material shown in *Figure 6*.

HEAT RESISTANT MATERIAL MEASUREMENT	YS24 REQUIREMENTS FOR SAFE INSTALLATION
20" or more	Hood not required.
8" to less than 20"	Extend heat resistant material to 20" or install Hood. <i>See Figure 6.</i>
Less than 8"	Extend heat resistant material to at least 8" and install hood. <i>See Figure 6.</i> OR , extend heat resistant material to a height of at least 20".

TABLE A - Heat Resistant Material Requirements with No Mantel or Combustible Projection

CLEARANCES AND HEIGHT REQUIREMENTS

HEAT RESISTANT MATERIAL MEASUREMENT	REQUIREMENTS FOR SAFE INSTALLATION WITH WOODEN MANTEL, SHELF OR OTHER COMBUSTIBLE PROJECTION
20" or more	Hood not required. Observe profiles (side elevations) shown in <i>Figure 8</i> .
8" to less than 12"	Install hood and observe profiles shown in <i>Figure 7</i> ; OR extend heat resistant material to at least 12" and observe profiles shown in <i>Figure 8</i> .
Less than 8"	Extend heat resistant material to at least 8", install hood and observe profiles shown in <i>Figure 7</i> ; OR extend heat resistant material to at least 12" and observe profiles shown in <i>Figure 8</i> .

TABLE B - Heat Resistant Material Heights and Mantel Location

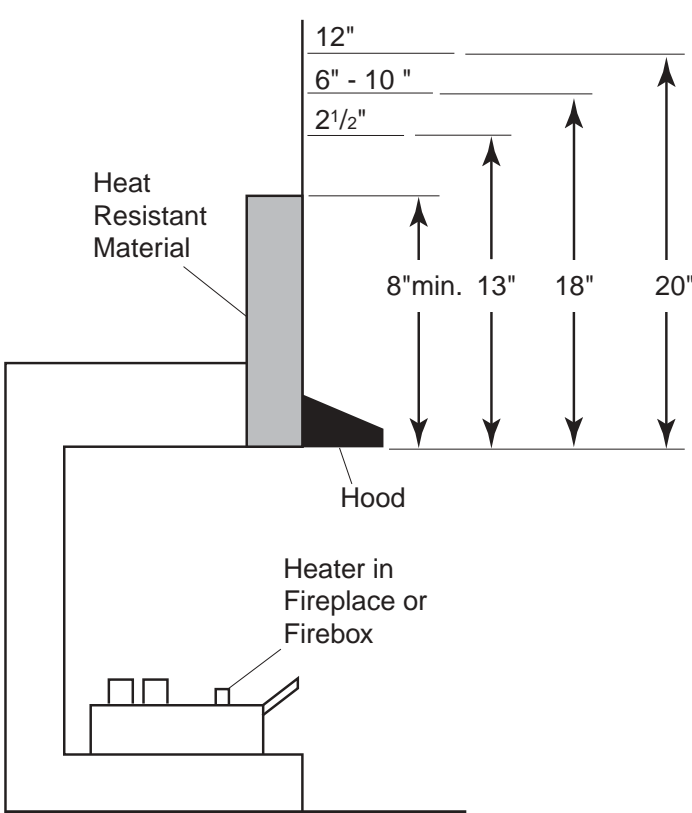

Figure 7 - Minimum Mantel Clearance with Hood

Example: A mantel may project from the wall a **maximum** of 2 1/2" at a **minimum** of 13" above the opening and a **maximum** of 10" at a **minimum** of 18" above the opening.

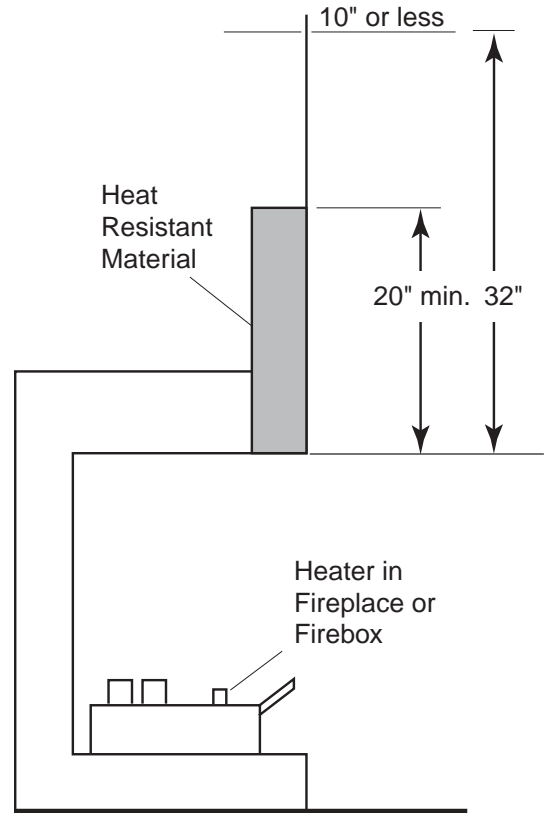

Figure 8 - Minimum Mantel Clearance with No Hood

Example: The bottom of the mantel may project from the wall a **maximum** of 10" at a **minimum** of 32" above the opening.

FLOOR CLEARANCE

The gas log heater must be installed at least 5" above any combustible flooring material, such as carpeting or tile, which is closer than 14" to the base of the fireplace. The minimum distance must be maintained from the top surface of carpeting, tile, etc. Refer to Figure 9.

OR,

The gas log heater may be installed nearer to the floor if a minimum of 14" of noncombustible material such as slate or marble is installed between the base of the fireplace and the combustible flooring. Refer to Figure 10.

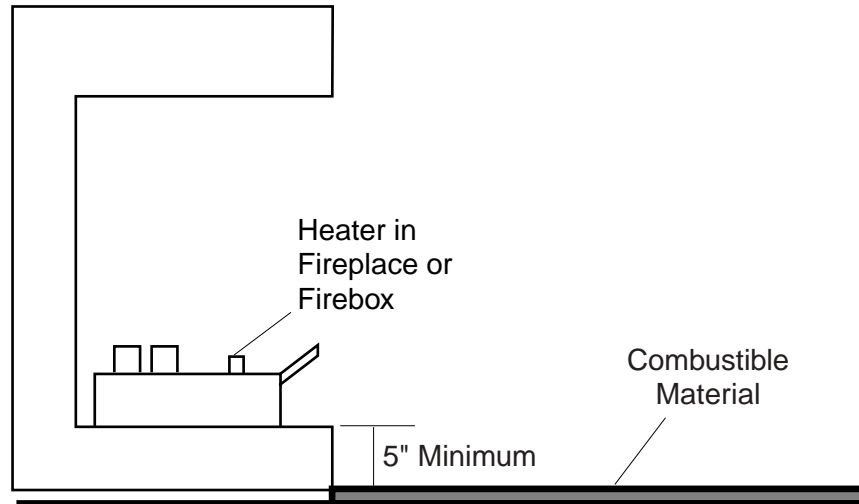

Figure 9 - Minimum Clearance above Combustible Flooring

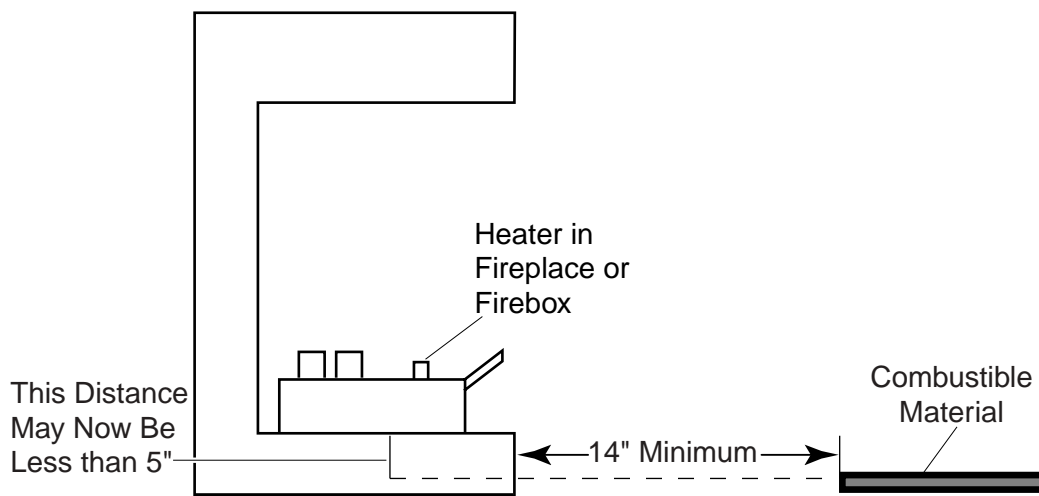

Figure 10 - Minimum Clearance above Combustible Flooring with Noncombustible Material Installed at Base of Fireplace

BEFORE FULLY INSTALLING THE UNIT:

- Turn **OFF** the gas supply to the fireplace or firebox.
- Seal any fresh air vents and/or ash clean-out doors located on the floor or wall of the fireplace. If left unsealed, drafting may cause pilot outage or sooting. Use a heat resistant sealant. **Do not seal the chimney flue damper.**

WARNING

Before installing in a solid fuel burning fireplace, The chimney flue and firebox must be cleaned of soot, creosote, ashes and loose paint by a qualified chimney cleaner.

INSTALLING VENTED APPLICATIONS

Manual and millivolt controlled gas logs may be installed as a vented decorative log set in compliance with ANSI Z21.60 and National Fuel Gas Code, Section 6.6 Since, the gas logs are operated with the damper open, non-combustible material and minimum mantel requirements do not apply.

WARNING

This appliance is for installation only in a solid fuel burning fireplace (masonry fireplace or manufactured fireplace) with a working flue and constructed of noncombustible material.

Exception: DO NOT install this appliance in a factory-built fireplace that includes instructions stating that it has not been tested or should not be used with unvented gas logs.

BEFORE INSTALLING THE APPLIANCE:

- Turn off gas supply to fireplace or firebox.
- Have the fireplace floor and chimney professionally cleaned to remove ashes, soot, creosote or other obstructions. Have this cleaning performed annually after installation.
- Seal any fresh air vents or ash clean-out doors located on floor or wall of fireplace. If not, drafting may cause pilot outage or sooting. Use a heat-resistant sealant. Do not seal chimney flue damper.

Install and operate the appliance as directed in this manual.

DAMPER STOP INSTALLATION:

A damper stop must be provided with the unit. Contact your dealer to obtain one. The damper stop must be installed as shown in *Figure 11* to prevent full closure of the fireplace damper blade and provide a minimum 29 square inch flue opening.

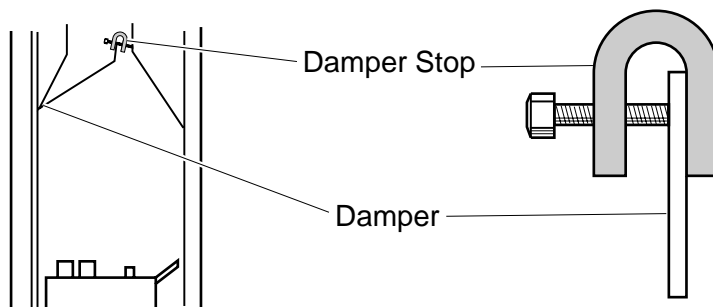

**Figure 11 - Damper Stop Installation.
(See WARNING at top of next page.)**

WARNING

The fireplace and gas logs function as a system. If the fireplace is spilling into the room (check with a match or a smoke stick), reposition the damper clamp until a positive draft is obtained by opening the damper. If negative pressure in home prevents having a positive draft, contact your dealer for assistance.

PLACING AND SECURING APPLIANCE

WARNING

You must secure the gas log heater to the fireplace floor. If not, the entire unit may move when you adjust the controls. Movement of unit may cause shifting of the gas logs which leads to sooting and improper burning. Grate movement could cause a gas leak.

Special care is required if you are installing the unit into a sunken fireplace. You must raise the fireplace floor to allow access to gas log controls. This will insure adequate air flow and guard against sooting. Raise the fireplace floor using noncombustible materials, as described in "PLACEMENT IN A FIREPLACE WITH RESTRICTIVE BARRIER" on page 10.

ASSEMBLY PROCEDURE:

1. Center the gas log unit in the fireplace or firebox. Make certain the front feet of the grate sit inside the front edge of the fireplace or firebox.
2. Anchor holes are located inside the back right corner and inside front left corner. After centering the grate correctly, mark the hole positions on the fireplace/firebox floor. Drill two (2) $\frac{5}{32}$ " diameter holes approximately $1\frac{1}{2}$ " deep.
3. Anchor the grate to the fireplace/firebox floor using the screws provided. *Refer to Figure 12.*

Proper installation of the grate is essential to prevent any movement of the gas logs and controls during operation.

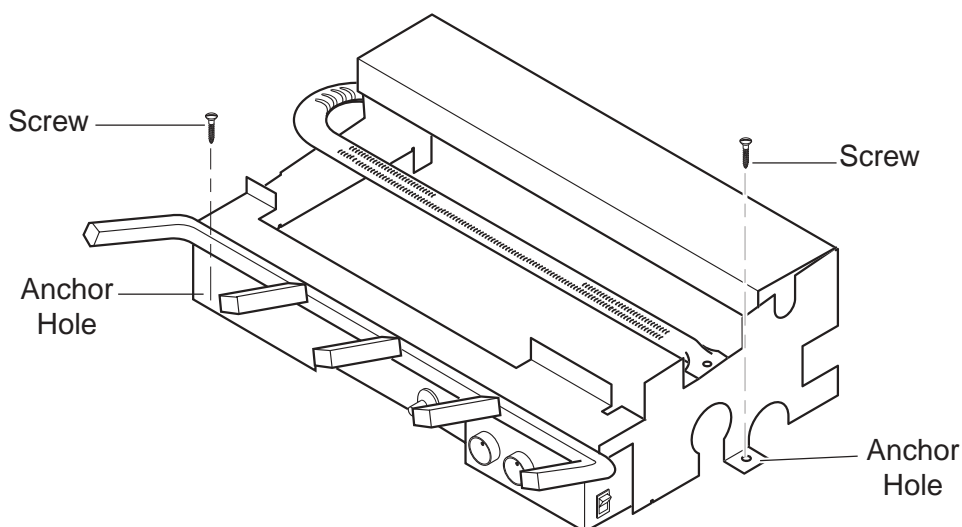

Figure 12 - Securing Heater to Floor of Fireplace/Firebox

CONNECTING THE GAS

NOTICE: A qualified gas appliance installer must connect the heater to the gas supply. Consult all local codes.

CAUTION

Use new black iron or steel pipe. Internally tinned copper or copper tubing can be used per National Fuel Code, section 2.6.3, providing gas meets hydrogen sulfide limits, and where permitted by local codes. Gas piping system must be sized to provide minimum inlet pressure (Listed on Data Plate) at the maximum flow rate (BTU/Hr). Undue pressure loss will occur if the pipe is too small.

A manual shutoff valve must be installed upstream of the appliance. Union tee and plugged $\frac{1}{8}$ " NPT pressure tapping point should be installed upstream of the appliance. Refer to Figure 13.

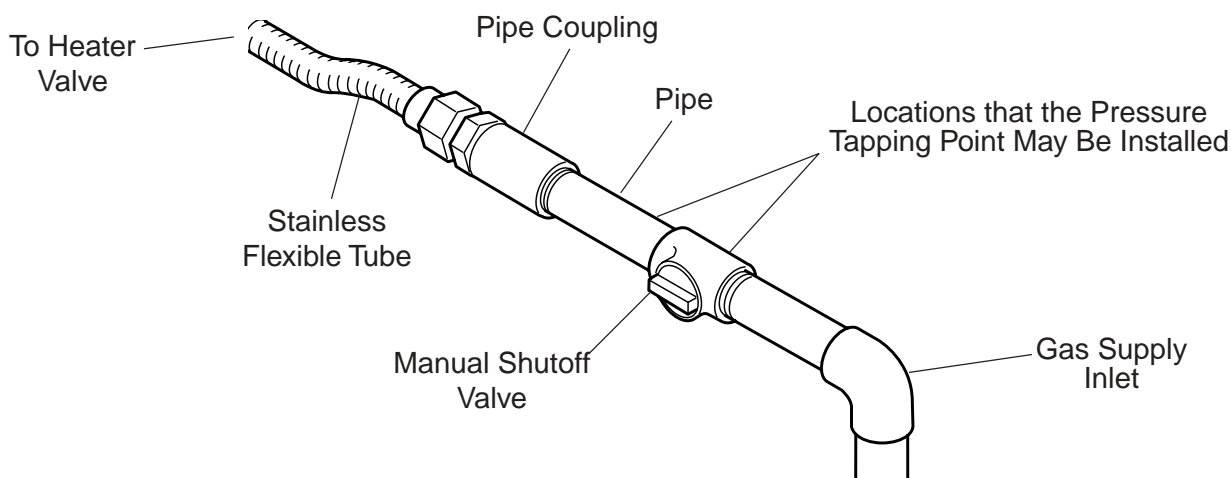

Figure 13 - Gas Connection

IMPORTANT: Hold heater valve firmly with a wrench to prevent movement when connecting to inlet pipe.

CAUTION

CHECK GAS TYPE: The gas supply must be the same as stated on the heater's rating plate. If the gas supply is different, **DO NOT INSTALL THE HEATER**. Contact your dealer for the correct model.

Always use an external regulator for all propane/LPG heaters and high pressure one to two-pound systems only, to reduce the supply tank pressure to a maximum of 13" w.c. This is in addition to the internal regulator in the heater valve.

WARNING

Connecting directly to an unregulated propane/LPG tank can cause an explosion.

The heater gas inlet connection is a $\frac{3}{8}$ " NPT at the valve. On units with Millivolt control, the inlet connection is on the right side, when you face the unit. On units with manual control, the inlet connection is on the right. To connect from the opposite side, route the pipe under the rear portion of the unit.

When tightening up the joint to the valve, hold the valve securely to prevent movement.

Test all gas joints from the gas meter to the heater valve for leaks using a gas analyzer or soap and water solution after completing connection. **DO NOT USE AN OPEN FLAME.**

Check the gas pressure with the appliance burning and the control set to **HIGH**.

MANUAL CONTROL (Figure 14)

The pressure regulator is preset and locked to discourage tampering. If the pressure is not as specified, replace the regulator with the correct part from the parts list in this manual.

Remove $\frac{1}{8}$ " NPT plug, located on side of regulator body. Install fitting and tubing to pressure gauge. After taking pressure reading, reinstall test plug. Check for gas leaks.

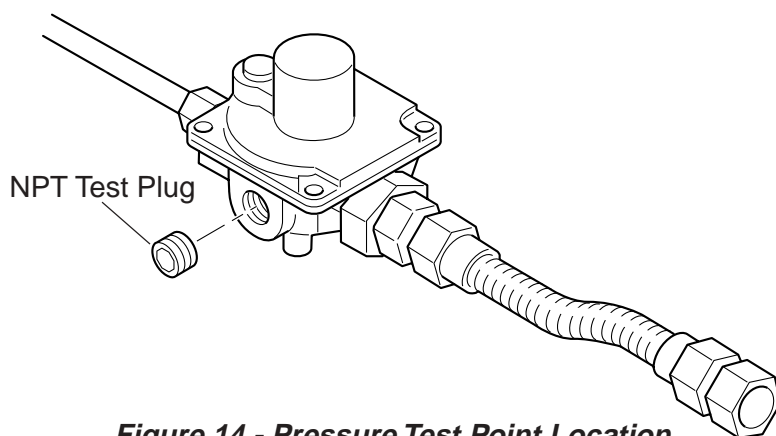
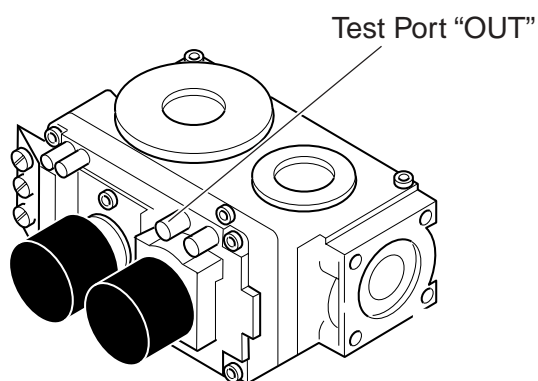

**Figure 14 - Pressure Test Point Location
Manual Control**

MILLIVOLT CONTROL (Figure 15)

The valve regulator controls the burner pressure which should be checked at the pressure test point.

Turn captured screw counter clockwise two or three turns and then place tubing to pressure gauge over test point (Use test point "OUT" closest to control knob). After taking pressure reading, be sure and turn captured screw clockwise firmly to re-seal. Do not over torque. Check for gas leaks.



**Figure 15 - Pressure Test Point Location
Milli-Volt Control**

ELECTRICAL WIRING (MILLI-VOLT)

The milli-volt valve is a self-powered combination gas control **THAT DOES NOT REQUIRE 110 VAC TO OPERATE.**

CAUTION

Label all wires prior to disconnection when servicing controls. Wiring errors can cause improper and dangerous operation. Verify proper operation after servicing.

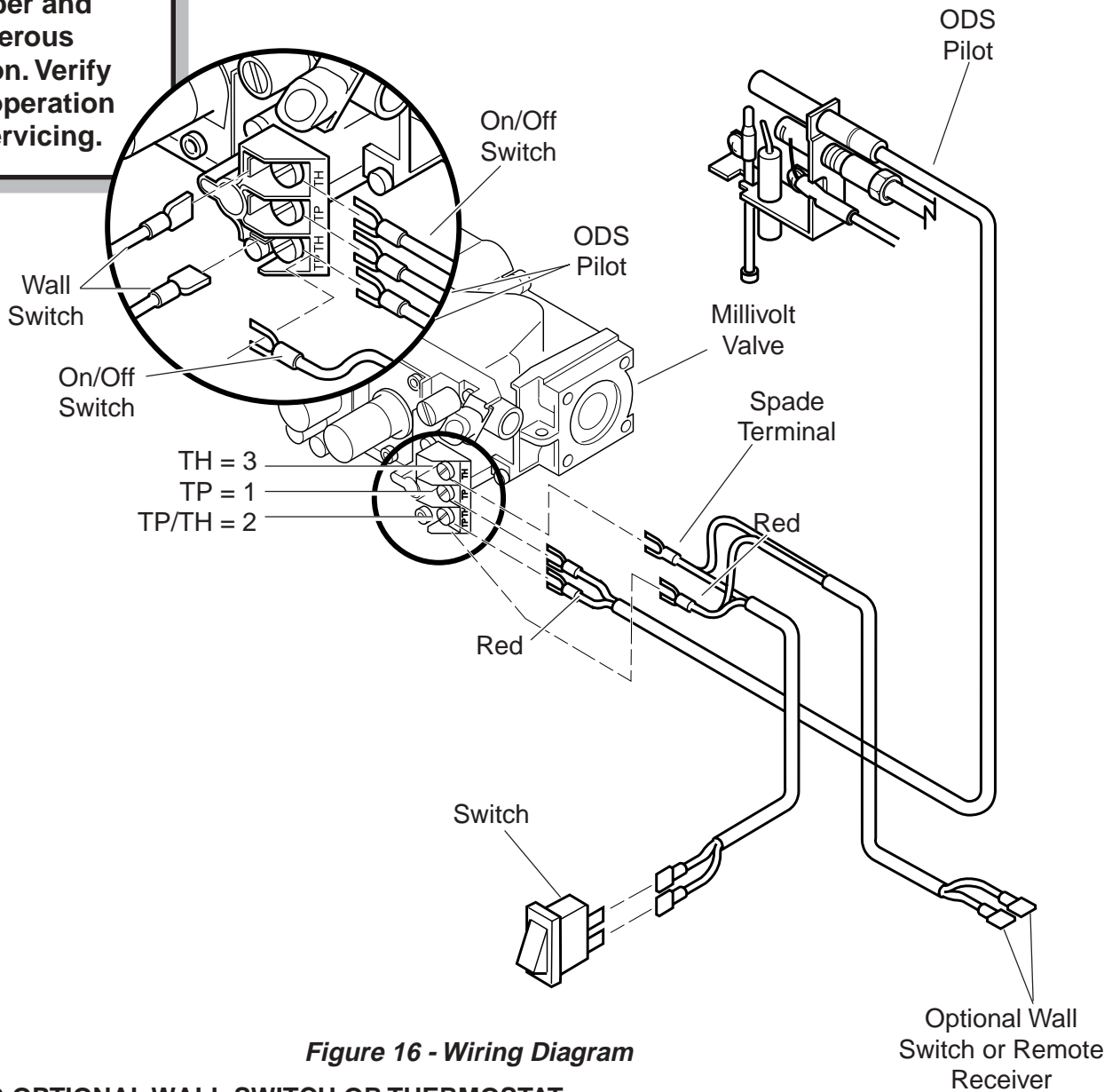

Figure 16 - Wiring Diagram

CONNECTING OPTIONAL WALL SWITCH OR THERMOSTAT

1. Use 18 awg, two-wire cable, 20 feet maximum length.
2. At one end of the cable, connect both wires to the wall switch or thermostat. At the other end, connect one wire to TP/TH and one wire to TH. The color of the wires does not matter. Or you can hook the wall switch of thermostat to wires on the left side of the unit.

CONNECTING REMOTE RECEIVER

THESE INSTRUCTIONS SUPERCEDE THE SECTION ENTITLED "HEARTH MOUNT" IN THE MILLI-VOLT HAND-HELD REMOTE INSTRUCTIONS SUPPLIED WITH THE REMOTE.

1. Cut cable to length (approximately 12") for placement in the fireplace.
2. Strip back 1/4" of the insulation from both ends of each wire.
3. Connect two .25 female connectors to the wires at one end of the cable.
4. Insert the opposite ends of the wires into the receiver wire terminals and tighten the screws.
5. Connect the connectors to the two .25" male connectors located on the left side when facing the unit (See Figure 16, page 19). Do not let wire touch grate or burner.
6. Stick velcro pads with self-adhesive backing to bottom of remote receiver and to the left side of the unit. Refer to Figure 17.
7. Attach remote receiver with velcro pads. Control switch must face forward.

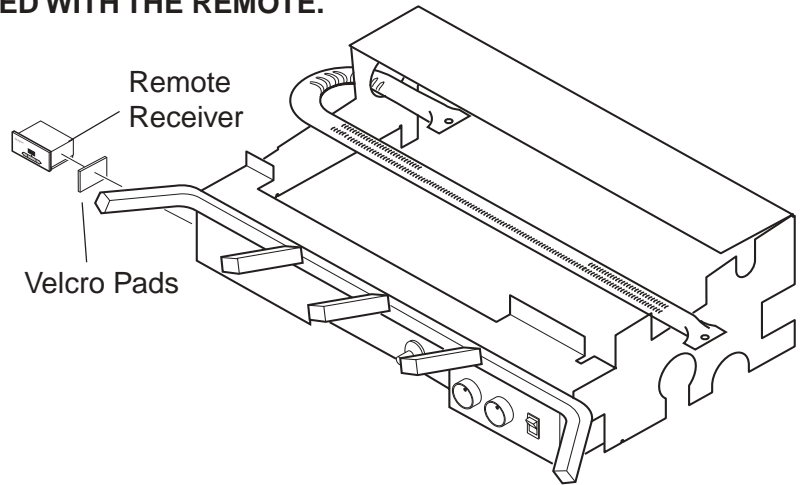

Figure 17 - Installing Remote Receiver

NOTE: Heat reduces battery life. You can protect the receiver and extend battery life by mounting the receiver in a wall or other location outside the fireplace.

CHECKING SYSTEM OPERATION

The milli-volt system and individual components may be checked with a millivolt meter having a 0-1000 mV range. Conduct each check shown in chart below by connection meter test leads to terminals as indicated.

CHECK TEST	TO TEST	CONNECT METER LEADS TO TERMINALS	THERMOSTAT CONTACTS	METER READING SHOULD BE
A	COMPLETE SYSTEM	2 & 3	CLOSED	CLOSED
B	THERMOPILE OUTPUT	1 & 2	OPEN	OPEN

A. COMPLETE MILLIVOLT SYSTEM CHECK

("A" Reading - Thermostat contacts CLOSED - Control Knob "ON" - Main burner should be come ON)

- a. If the reading is more than 100 milli-volts and the automatic valve still does not come on, replace the control.
- b. If the closed circuit reading ("A" reading) is less than 100 millivolts, determine cause for low reading, proceed to Section B below.

B. Thermopile Output Reading Check

("B" Reading - Thermostat contacts OPEN - Main burner OFF)

1. Check gas pressure to the unit. If gas pressure is within minimum and maximum on data plate, then check pilot voltage, 325 millivolts minimum. If the minimum milli-volt reading is not obtainable, replace pilot.

Before you begin — This unit is supplied with a two ceramic fiber log units. Do not handle the log unit with your bare hands. **Always wear gloves to prevent skin irritation from ceramic fibers.** After handling the log unit, wash your hands gently with soap and water to remove any traces of fibers.

WARNING

The positioning of the log unit is critical to the safe and clean operation of this heater. Sooting and other problems may result if the logs are not properly and firmly positioned in the appliance. **Never add additional logs or embellishments such as pine cones, vermiculite or rock wool to the heater. Only use the log unit supplied with the unit.**

Failure to position the parts in accordance with diagrams below or to use only parts specifically approved for this heater may result in property damage or personal injury.

INSTALLING LOG UNIT ON GRATE

1. Install bottom log on two log pins on base. Check log position and stability.
2. Install top log on two log pins on bottom log. Make sure top log is completely seated on bottom log.

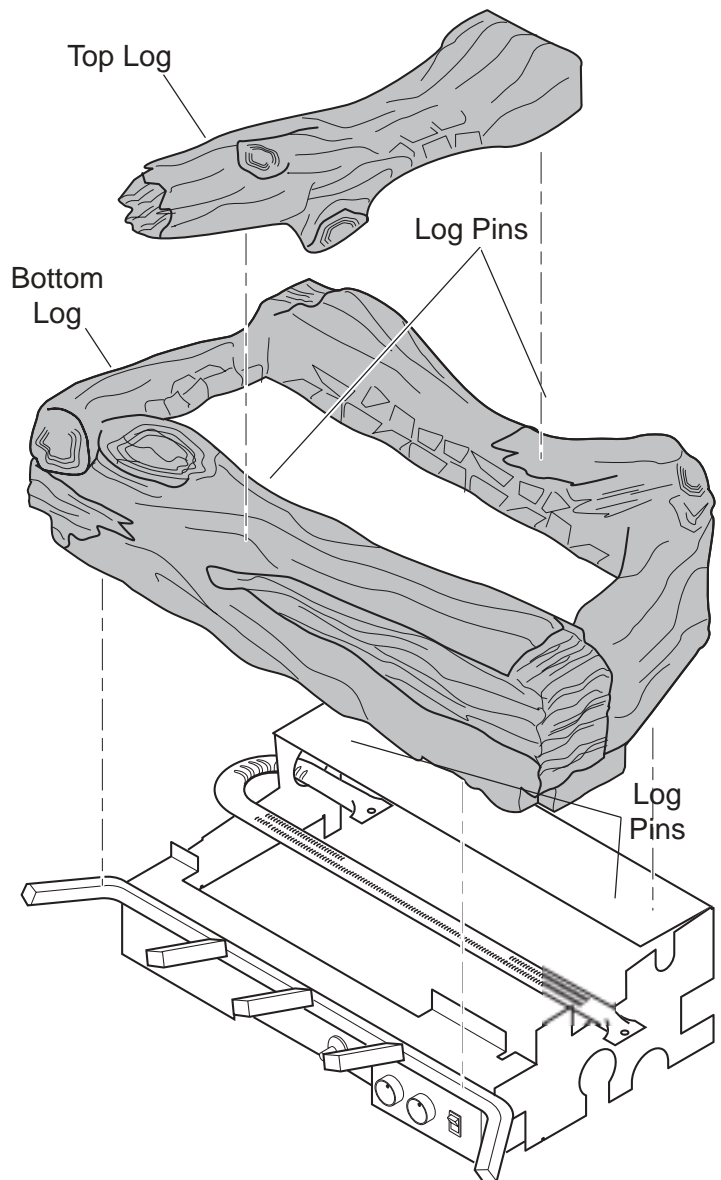

Figure 18 - Installing Logs to Grate

PLACING THE DECORATIVE ROCK

CAUTION

DO NOT sprinkle volcanic rock on the logs or around the pilot or the main burner. This may cause sooting. Only place volcanic rock on the floor of the fireplace. During initial operation of the new heater, burning logs will give off a paper burning smell and orange flames will be present. Simply open the windows for a few hours to vent the odor.

FLAME APPEARANCE

Flames from the pilot, front and rear burner should be visually checked as soon as the heater is installed. In addition, periodically check the flames visually during operation.

CHECKING THE PILOT FLAME

The pilot flame must always be present when the heater is in operation. It should just touch the top of the thermocouple tip for natural. Refer to Figures 19 and 21 for correct pilot flame.

If the pilot flame does not touch the thermocouple, then the main burner cannot function reliably. Refer to Figures 20 and 22 for incorrect shape of pilot flame.

MILLI-VOLT CONTROL

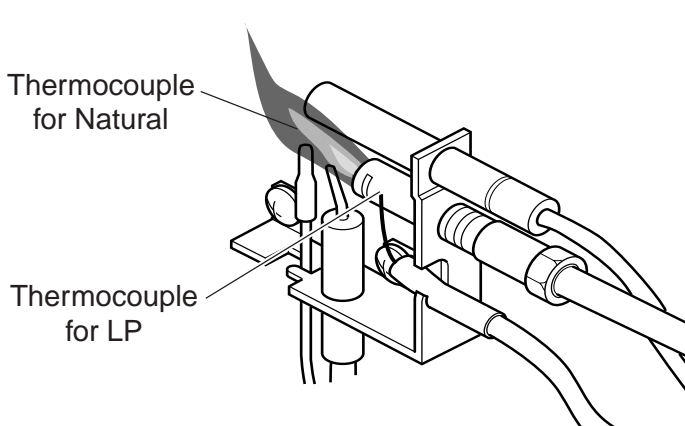

Figure 19 - Correct Appearance of Pilot Flame

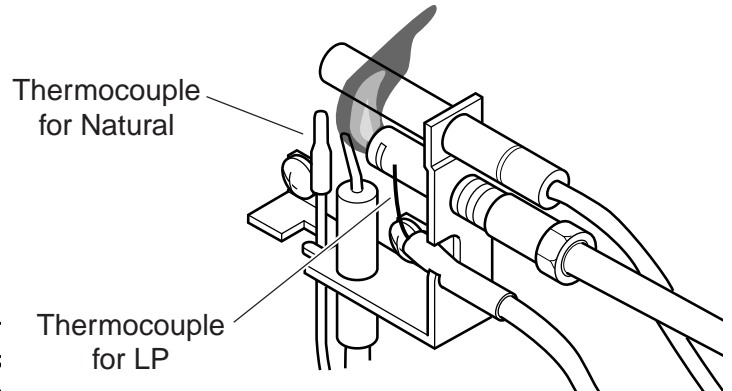

Figure 20 - Incorrect Appearance of Pilot Flame

MANUAL CONTROL

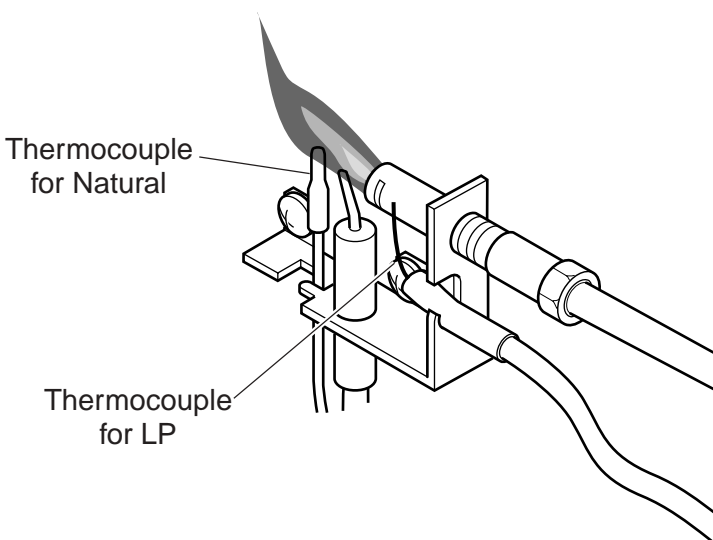

Figure 21 - Correct Appearance of Pilot Flame

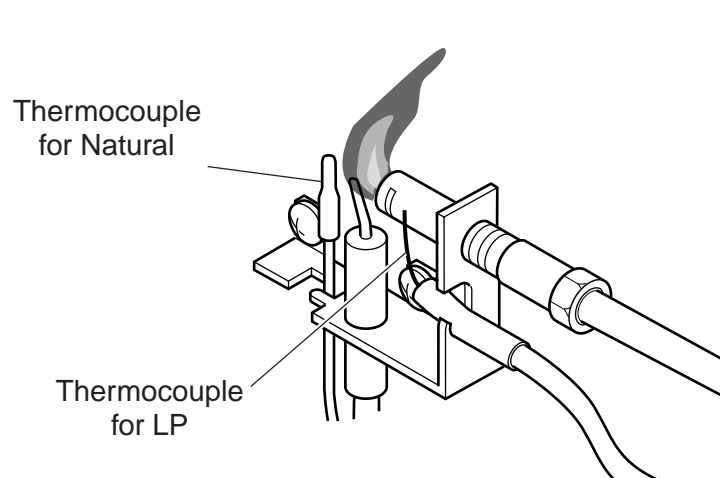

Figure 22 - Incorrect Appearance of Pilot Flame

CHECKING THE BURNER FLAME

In normal operation at full rate after 15 minutes, the following flame appearances should be observed:

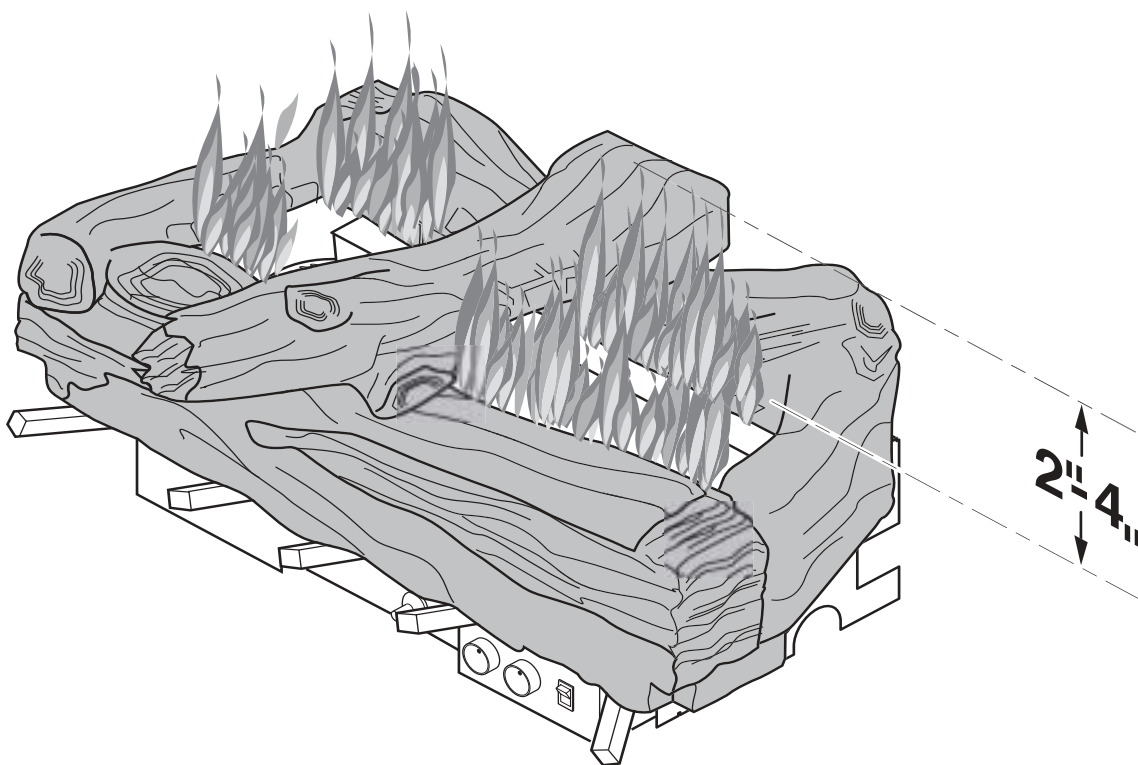

Figure 23 - Correct Appearance of Rear Flames

The left and right flames should be yellow and extend 1"-2" above the log top surfaces. The yellow flames should **not** contact the logs.

OPERATING INSTRUCTIONS

Avoid any drafts that alter burner flame patterns. Do not allow fans to blow directly into the fireplace. Do not place a blower inside the burn area of the firebox. Ceiling fans may create drafts that alter flame patterns. Sooting and improper burning will result.

During manufacturing, fabricating and shipping, various components of this appliance are treated with certain oils, films or bonding agents. These chemicals are not harmful, but may produce annoying smoke and smells as they are burned off during the initial operation of the appliance, possibly causing headaches or eye or lung irritation. *This is a normal and temporary occurrence.*

The initial break-in operation should last two to three hours with the burner at the highest setting. Provide maximum ventilation by opening windows or doors to allow odors to dissipate. Any odors remaining after this initial break-in will be slight and will disappear with continued use.

This appliance must not be used with glass doors in the closed position. This can lead to pilot outages and severe sooting outside the fireplace.

OPERATING INSTRUCTIONS

FOR YOUR SAFETY READ BEFORE LIGHTING

WARNING

If you do not follow these instructions exactly, a fire or explosion may result causing property damage, personal injury or loss of life.

- A.** This appliance is equipped with an ignition device which automatically lights the pilot. Do not try to light the unit by hand.
- B.** BEFORE OPERATING smell all around the appliance area for gas. Be sure to smell next to the floor because some gas is heavier than air and will settle on the floor.

WHAT TO DO IF YOU SMELL GAS:

- Do not attempt to light any appliance.
 - Do not touch any electric switch; do not use any phone in your building.
 - Immediately call your gas supplier from a neighbor's phone. Follow the gas supplier's instructions.
 - If you cannot reach your gas supplier, call the fire department.
- C.** Use only your hand to push in, or turn the gas control knob. Never use tools. If the knob will not push in or turn by hand, don't try to repair it. Call a qualified service technician. Force or attempted repair may result in a fire or explosion.
- D.** Do not use this appliance if any part of it has been under water. Immediately call a qualified service technician to inspect the appliance and to replace any part of the control system and any gas control that has been under water.

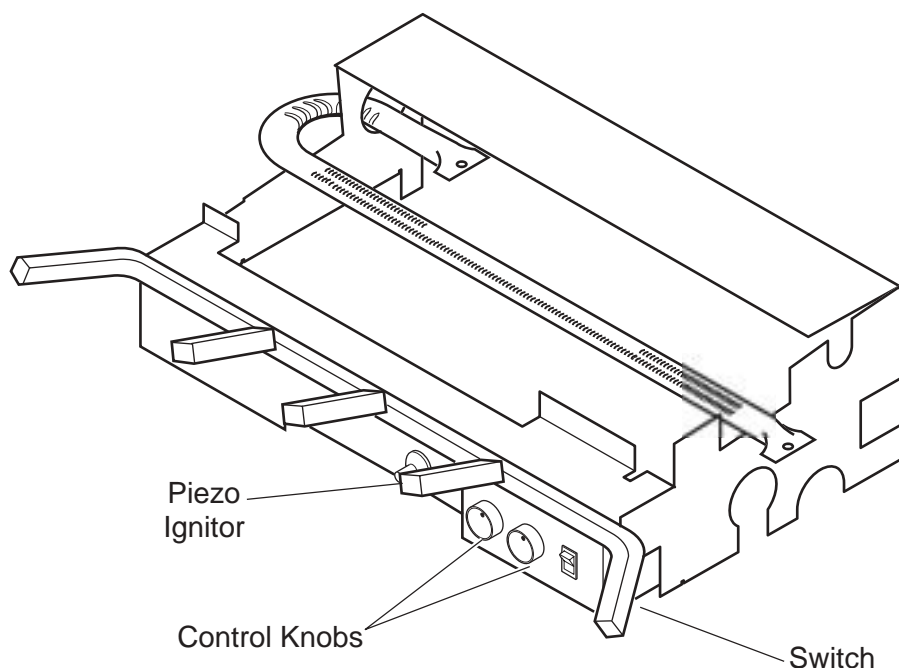
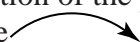





Figure 24 - Location of Piezo Ignitor, Control Knobs and Switch on Millivolt Unit

MANUAL CONTROL LIGHTING INSTRUCTIONS

1. STOP! Read the safety information.
2. Make sure the manual shutoff valve is fully open.
3. This heater is equipped with an ignition device (piezo) which automatically lights the pilot.
4. Refer to *Figure 24, page 24* for the location of the piezo ignitor and control knob. Push in gas control knob slightly and turn control knob clockwise  to the OFF position.
NOTE: Knob cannot be turned to OFF unless knob is pushed in slightly. Do not force.
5. Wait 5 minutes to clear out any gas. Then smell for gas, including near the floor. If you smell gas STOP! Follow the instructions under “WHAT TO DO IF YOU SMELL GAS”, page 24. If you do not smell gas, go to the next step.
6. From OFF position, push in gas control knob slightly and turn counterclockwise  to the IGN position. See *Figure 25*. Push in and hold control knob for 5 seconds.
NOTE: If you are running the heater for the first time, it will be necessary to press in the control knob for 30 seconds to allow air to bleed out of the gas piping.
7. With the control knob pushed in, push and release the piezo ignitor button to light the ODS pilot. The pilot is located on the right side of the heater, behind the front log and in front of the main burner. If piezo ignitor does not light the pilot, refer to “MATCH LIGHTING INSTRUCTIONS”, page 27.
8. Hold the control knob in for an additional 10 seconds to prevent the ODS pilot from shutting off the gas while the thermocouple is warming up.
9. Release the control knob.
 - If the knob does not pop out when released, stop and immediately call your service technician or gas supplier.
 - If the ODS pilot will not stay lit after several tries, push and turn the gas control knob clockwise  to OFF and wait 15 seconds. Repeat steps 6 through 9.
10. Push in control knob and turn counterclockwise  to the HIGH setting. At this location the control knob will pop out when positioned correctly. The knob can now be positioned at any position between HIGH and LOW. Refer to *Figures 26 and 27*.

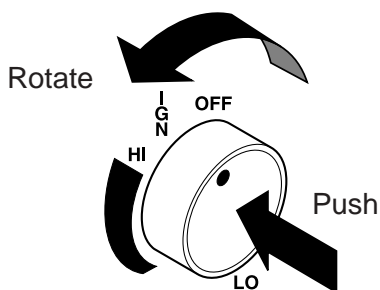

Figure 25 - IGN Position

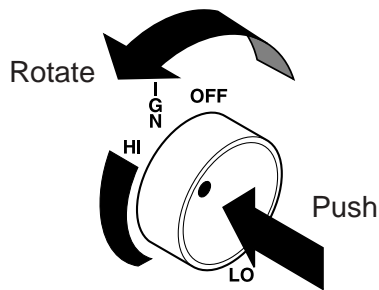

Figure 26 - HIGH Position

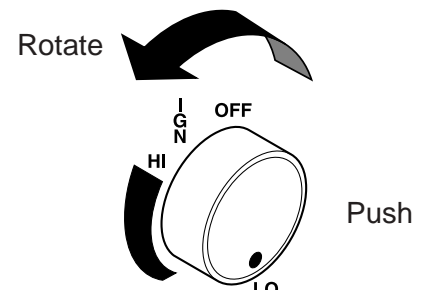



Figure 27 - LOW Position

WARNING



Wait 30 seconds before readjusting the heater when the control knob has been turned down to a lower setting.

TO TURN OFF GAS TO HEATER

1. Turn control knob clockwise  to OFF position to completely shut off the heater.
2. If applicable: Turn off all electric power to the heater.

OPERATING INSTRUCTIONS

MILLI-VOLT CONTROL LIGHTING INSTRUCTIONS

1. STOP! Read the safety information label.
2. Make sure the manual shutoff valve is fully open.
3. This gas log set is equipped with an ignition device (piezo) which automatically lights the pilot. If piezo ignitor does not light the pilot, refer to instructions for "MATCH LIGHTING INSTRUCTIONS", page 27.
4. Turn gas control knob clockwise  to the OFF position, set the thermostat to the lowest setting and turn ON/OFF switch to OFF position.
5. Wait (5) minutes to clear out any gas. Then smell for gas, including near the floor. If you smell gas, STOP! Follow "B" in the safety information label. If you don't smell gas, go to next step.
6. From OFF position, turn the gas control knob counterclockwise  to IGN position. Push in control knob for 5 seconds.
7. With the control knob pushed in, push in and release the piezo ignitor button to light the pilot.
8. Continue pushing the control knob in for a further 60 seconds to prevent the flame detector from shutting off the gas while the probe is warming up. Release the control knob.
9. Turn gas control knob counterclockwise  to the ON position.
10. After the pilot has been lit for one minute, the burners can be turned on. Turn the ON/OFF switch to ON position or adjust thermostat to desired setting.
11. If the gas logs will not operate, follow the instructions "TO TURN OFF GAS TO APPLIANCE" below and call your service technician or gas supplier.

WARNING

Wait 30 seconds before readjusting the heater when the control knob has been turned down to a lower setting.

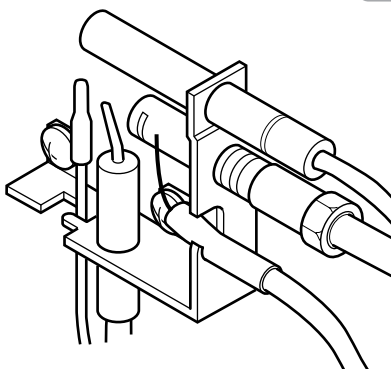

Figure 28 - Pilot

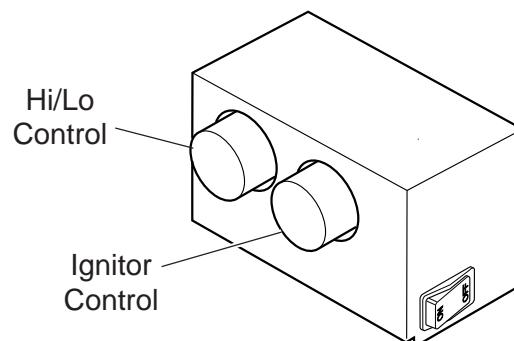



Figure 29 - Control Cover Plate

TO TURN OFF GAS TO HEATER

1. Turn control knob clockwise  to **OFF** position to completely shut off the heater.
2. If applicable: Turn ON/OFF switch to OFF position and/or set thermostat (if present) to lowest setting.
3. If applicable: Turn off all electric power to the heater.

OPERATING INSTRUCTIONS AND CLEANING AND SERVICING

MATCH LIGHTING INSTRUCTIONS

1. Remove any items necessary for easy access to the pilot (for example: logs, screens, etc.).
2. Follow appropriate lighting instructions found previously. Instead of pushing and releasing the piezo button, light a match and hold the flame to the end of the pilot and ignite the pilot.
3. After control knob has been released and pilot stays lit, reinstall any items that were removed for pilot access.
4. Call a qualified service technician for repair or replacement of the piezo ignitor.

CLEANING AND SERVICING

Annual inspection and cleaning by your dealer or qualified service technician is recommended to prevent malfunction and/or sooting.

WARNING

Turn off heater and allow to cool before cleaning. Disconnect electrical power (optional blower) before cleaning or servicing.

Remove fireplace screen. Carefully lower screen from mounting lugs and set aside during cleaning. Refer to instruction manual for installation of screen. **DO NOT OPERATE THE UNIT WITH THE SCREEN REMOVED.**

Remove logs, handling carefully by holding gently at each end. Gloves are recommended to prevent skin irritation from ceramic fibers. If skin becomes irritated, wash gently with soap and water. Refer to manual for correct log placement.

PERIODIC CLEANING - Refer to parts diagram for location of items discussed below.

- Do not use cleaning fluid to clean logs or any part of heater.
- Brush logs with soft bristle brush or vacuum with brush attachment.
- Vacuum loose particles and dust from the front and rear burner, control and piezo covers and grate weldment.
- Inspect and clean burner air intake holes. Remove lint or particles with vacuum, brush, or pipe cleaners. Failure to keep air intake holes clean will result in sooting and poor combustion.
- External case should be dusted and wiped with a wet soapy cloth.

ANNUAL CLEANING/INSPECTION - Refer to parts diagram for location of items discussed below.

- Inspect and clean burner air intake holes. Remove lint or particles with vacuum, brush or pipe cleaners. Failure to keep air intake holes clean will result in sooting and poor combustion.
- Inspect and clean all burner ports.
- Inspect ODS pilot for operation and accumulation of lint at air intake holes.
- Verify flame pattern and log placement for proper operation.
- Verify smooth and responsive ignition of main burner and rear burner.

TROUBLESHOOTING

WARNING

Turn appliance OFF and allow to cool before servicing. Only a qualified service person should service and repair the heater.

Note: All troubleshooting items are listed in order of operation.

OBSERVED PROBLEM	POSSIBLE CAUSE	REMEDY
When ignitor button is pressed, there is no spark at ODS/pilot.	<ol style="list-style-type: none">1. Ignitor electrode positioned wrong.2. Ignitor electrode is broken.3. Ignitor electrode not connected to ignitor cable.4. Ignitor cable pinched or wet. Keep ignitor cable dry.5. Broken ignitor cable.6. Bad piezo ignitor.	<ol style="list-style-type: none">1. Replace ignitor.2. Replace ignitor.3. Reconnect ignitor cable.4. Free ignitor cable if pinched by any metal or tubing.5. Replace ignitor cable.6. Replace piezo ignitor.
Appliance produces unwanted odors.	<ol style="list-style-type: none">1. Appliance burning vapors from paint, hair spray, glues, etc.2. Gas leak.3. Initial burn off.	<ol style="list-style-type: none">1. Ventilate room. Stop using odor causing products while heater is running.2. Locate and correct all leaks.3. Ventilate room and turn unit on high until odor is gone. Odor should be gone after 2 to 3 hours of continuous use.
Appliance shuts off during use.	<ol style="list-style-type: none">1. Not enough fresh air is available for ODS/ pilot to operate.2. Low line pressure.3. ODS/pilot is partially clogged.4. Defective Thermopile. 5. Restrictions in incoming air flow.	<ol style="list-style-type: none">1. Open window and/or door for ventilation.2. Contact local gas company.3. Clean ODS/pilot.4. Check pilot flame, check wire connections, check output, should be 325 millivolts across TH/TP and TP Terminals with ON/OFF switches off.5. Check for bottom riser on glass door, sunken fireplace, excessive lava rock/cinders densely packed against grate.
Gas odor even when control knob is in OFF position.	<ol style="list-style-type: none">1. Gas leak.2. Control valve defective.	<ol style="list-style-type: none">1. Locate and correct all leaks.2. Replace control valve.
When ignitor button is pressed, there is spark at ODS pilot, but no ignition.	<ol style="list-style-type: none">1. Gas supply turned off or manual shutoff valve closed.2. Control knob not in PILOT position.3. Control knob not pressed in while in PILOT position.4. Air in gas lines when installed. 5. ODS/pilot is clogged. 6. Gas regulator setting is not correct.	<ol style="list-style-type: none">1. Turn on gas supply or open manual shutoff valve.2. Turn control knob to PILOT position.3. Press in control knob while in PILOT position.4. Continue holding down control knob. Repeat igniting operation until air is removed.5. Replace ODS/pilot assembly or get it serviced.6. Replace gas regulator.

WARNING

If the gas quality is bad, your pilot may not stay lit, the burners may produce soot and the heater may backfire when lit. If the gas quality or pressure is low, contact your local gas supplier immediately.

OBSERVED PROBLEM	POSSIBLE CAUSE	REMEDY
ODS/pilot lights, but flame goes out when control knob is released.	<ol style="list-style-type: none"> Control knob not fully pressed in. Control knob not pressed in long enough. Manual shutoff valve not fully open. Thermocouple connection loose at control valve. Pilot flame not touching thermocouple, which allows thermocouple to cool, causing pilot flame to go out. This problem could be caused by either low gas pressure, or a dirty or partially clogged ODS/pilot. Thermocouple damaged. Control valve damaged. 	<ol style="list-style-type: none"> Press in control knob fully. After ODS/pilot lights, keep control knob pressed in for 30 seconds. Fully open manual shutoff valve. Hand tighten until snug, then tighten 1/4 turn more. Contact local gas company. Replace thermocouple. Replace control valve.
Burner does not light after ODS/pilot is lit.	<ol style="list-style-type: none"> Burner orifice is clogged. Burner orifice diameter is too small. Inlet gas pressure is too low. 	<ol style="list-style-type: none"> Clean burner or replace burner orifice. Replace burner orifice. Contact qualified service person.
Burner backfires during combustion.	<ol style="list-style-type: none"> Manifold pressure is too low. Burner orifice is clogged. 	<ol style="list-style-type: none"> Contact local gas company. Clean burner or replace burner orifice.
Slight smoke or odor during initial operation.	<ol style="list-style-type: none"> Burner orifice is clogged or damaged. Burner is damaged. Gas regulator defective. 	<ol style="list-style-type: none"> Clean burner or replace burner orifice. Replace burner. Replace gas regulator.
Logs appear to smoke after initial operation.	<ol style="list-style-type: none"> Vapors from paint or curing process of logs. 	<ol style="list-style-type: none"> Problem will stop after a few hours of operation. Run the heater with the damper open if you have one, or open a window for the first few hours. Log heater is intended to be smokeless. Turn OFF heater and call qualified service person.
Heater produces a whistling noise when burner is lit.	<ol style="list-style-type: none"> Turning control knob to HIGH position when burner is cold. Air in gas line. Dirty or partially clogged burners orifice. 	<ol style="list-style-type: none"> Turn control knob to LOW position and let warm up for a minute. Operate burner until air is removed from line. Have gas line checked by local gas company. Clean burner or replace burner orifice.
No gas to pilot.	<ol style="list-style-type: none"> LP-regulator shut down due to inlet pressure too high. 	<ol style="list-style-type: none"> Verify LP tank regulator is installed and set at 11" to 13" w.c. Replace regulator on heater.

ILLUSTRATED PARTS BREAKDOWN

WARNING

Failure to position the parts in accordance with these diagrams or failure to use only parts specifically approved with this appliance may result in property damage or personal injury.

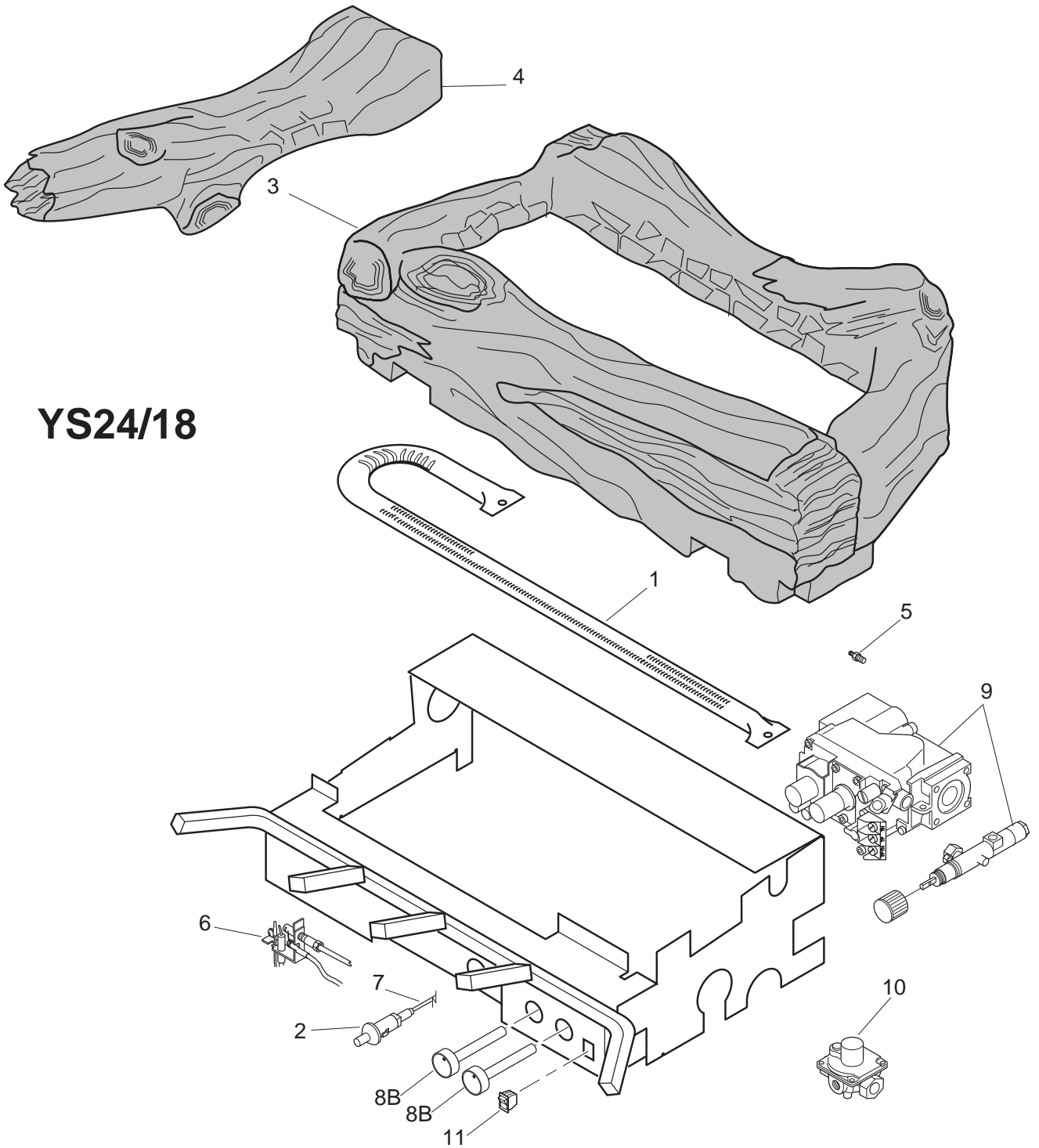

REPLACEMENT PARTS LIST

REPLACEMENT PARTS ARE AVAILABLE THROUGH YOUR RETAILER.

Item	Description	Qty	Natural	Propane
Common Parts				
1	Burner	1	39D3006	39D3007
2	Piezo Ignitor	1	14D0503	14D0503
3	Main Log	1	39D3014	39D3014
4	Top Log	1	36D3015	36D3015
Manual Control				
5	Injector	1	39D3029	39D3027
6	ODS Pilot Assembly	1	26D2529	26D2530
7	Piezo Wire	1	00K0632	00K0632
8	Knob Control	1	18D0603	18D0603
9	Control Valve	1	30D0201	30D0202
10	Regulator Valve	1	24D0305	24D0306
Millivolt Control				
5	Injector	1	39D3028	39D3027
6	ODS Pilot Assembly	1	14D0473	14D0474
7	Piezo Wire	1	00K0632	00K0632
8A	High/Low Knob Extension	1	37D0010	37D0010
8B	Pilot/On/Off Knob Extension	1	37D0011	37D0011
9	Control Valve	1	14D0467	14D0468
10	Regulator Valve		N/A	N/A
11	On/Off Switch	1	32D0232	32D0232
Accessories				
	Flex Connector		Flexcon 30	All Models
	Wall Switch Kit		MVWS	Milli-volt only
	Wall Thermostat Kit		MVWTS	Milli-volt only
	Hand Held Remote		MRC	Milli-volt only
	Hand Held Thermostat Remote		TRC	Milli-volt only

MONESSEN HEARTH SYSTEMS

LIMITED LIFETIME WARRANTY POLICY

LIFETIME WARRANTY

The following components are warranted for life to the original owner, subject of proof of purchase: Firebox, Combustion Chamber, Heat Exchanger, Grate and Stainless Steel Burners.

FIVE YEAR WARRANTY

The following components are warranted for 5 years to the original owner, subject of proof of purchase: Ceramic Fiber Logs, Catalytic Filter and Aluminized Burners.

BASIC WARRANTY

Monessen Hearth Systems (MHS) warrants the components and materials in your gas appliance to be free from manufacturing and material defects for a period of two years from date of installation. After installation, if any of the components manufactured by MHS in the appliance are found to be defective in materials or workmanship, MHS will, at its option, replace or repair the defective components at no charge to the original owner. MHS will also pay for reasonable labor costs incurred in replacing or repairing such components for a period of two years from the date of installation. Any products presented for warranty repair must be accompanied by a dated proof of purchase.

This Limited Lifetime Warranty will be void if the appliance is not installed by a qualified installer in accordance with the installation instructions. The Limited Lifetime Warranty will also be void if the appliance is not operated and maintained according to the operating instructions supplied with the appliance, and does not extend to (1) firebox/burner assembly damage by accident, neglect, misuse, abuse, alteration, negligence of others, including the installation thereof by unqualified installers, (2) the costs of removal, reinstallation or transportation of defective parts on the appliance, or (3) incidental or consequential damage. All service work must be performed by an authorized service representative.

This warranty is expressly in lieu of other warranties, express or implied, including the warranty of merchantability of fitness for purpose and of all other obligations or liabilities. Monessen Hearth Systems, Inc. does not assume for it any other obligations or liability in connection with the sale or use of the appliance. In states that do not allow limitations on how long an implied warranty lasts, or do not allow exclusion of indirect damage, those limitations of exclusions may not apply to you. You may also have additional rights not covered in this Limited Lifetime Warranty.

MHS reserves the right to investigate any and all claims against the Limited Lifetime Warranty and decide upon method of settlement.

For information about this warranty, contact:

**Technical Services
Monessen Hearth Systems
149 Cleveland Drive
Paris, Kentucky 40361**