

3000 SERIES

DIRECT VENT GAS FIREPLACE

INSTALLATION AND OPERATING INSTRUCTIONS

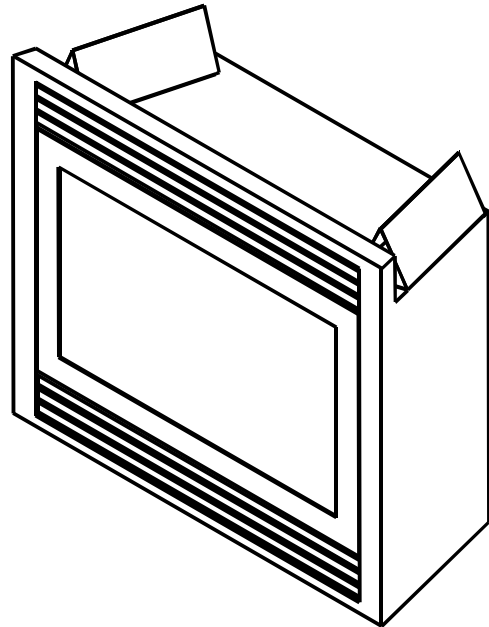

WARNING

If the information in these instructions are not followed exactly, a fire or explosion may result causing property damage, personal injury or loss of life.

- Do not store or use gasoline or other flammable vapors and liquids in the vicinity of this or any other appliance.

WHAT TO DO IF YOU SMELL GAS

- Do not try to light any appliance.
- Do not touch any electrical switch.
- Do not use any phone in your building.
- Immediately call your gas supplier from a neighbor's phone. Follow the gas supplier's instructions.
- If you cannot reach your gas supplier, call the fire department.

- Installation and service must be performed by a qualified installer, service agency or the gas supplier.

This appliance may be installed in an aftermarket, permanently located, manufactured (mobile home, where not prohibited by local codes.

This appliance is only for use with the type of gas indicated on the rating plate. This appliance is not convertible for use with other gases, unless a certified kit is used.

For Residential Use-Meets All HUD Requirements For Manufactured Housing Installations

DUE TO HIGH TEMPERATURES, THE APPLIANCE SHOULD BE LOCATED OUT OF TRAFFIC AND AWAY FROM FURNITURE AND DRAPERIES.

CHILDREN AND ADULTS SHOULD BE ALERTED TO THE HAZARDS OF HIGH SURFACE TEMPERATURE AND SHOULD STAY AWAY TO AVOID BURNS OR CLOTHING IGNITION.

YOUNG CHILDREN SHOULD BE SUPERVISED WHEN THEY ARE IN THE SAME ROOM AS THE APPLIANCE.

CLOTHING OR OTHER FLAMMABLE MATERIAL SHOULD NOT BE PLACED ON OR NEAR THE APPLIANCE.

KEEP THE ROOM AREA CLEAR AND FREE FROM COMBUSTIBLE MATERIALS, GASOLINE, AND OTHER FLAMMABLE VAPORS AND LIQUIDS.

TABLE OF CONTENTS

IMPORTANT SAFETY INFORMATION:	2
PRODUCT SPECIFICATIONS:	3
HIGH ALTITUDE INSTALLATIONS.....	3
LISTING & CODE APPROVAL:	3
PRE-INSTALLATION INFORMATION:	4
BEFORE YOU START:	4
FIREPLACE LOCATION:.....	4
WALL AND CEILING CLEARANCE REQUIREMENTS:	6
COMBUSTIBLE CLEARANCES:	6
MANTEL CLEARANCES:	7
FLOOR CLEARANCES:	7
MINIMUM VENT CLEARANCES TO COMBUSTIBLE MATERIALS:	7
FRAMING DIMENSIONS:	8
FINISHING MATERIAL:	9
VENT INSTALLATION:	10
POSITIONING THE FIREPLACE:.....	10
VENTING CONFIGURATION:	10
INSTALLING VENT COMPONENTS	12
BEFORE YOU START:	12
PIPING INSTALLATIONS:.....	12
VENT TERMINATION:	15
GAS LINE AND ELECTRICAL	19
GAS LINE INSTALLATION:.....	19
ELECTRICAL WIRING:	20
FINAL INSTALLATION	26
WALL FINISHING:.....	26
FINISHING THE FIREPLACE FLUSH WITH A WALL:	26
INSTALLATION COMPONENTS ON FIREPLACE:	26
GLASS REMOVAL:	27
ROCK WOOL PLACEMENT:.....	28
LOG PLACEMENT:.....	29
OPERATING INSTRUCTIONS	30
BEFORE LIGHTING THE FIREPLACE:.....	30
DURING LIGHTING THE FIREPLACE:	30
MAINTENANCE	33
BURNER & CONTROL COMPARTMENT:	33
PILOT FLAME:	33
BURNER FLAME:	33
VENT SYSTEM:.....	34
GLASS DOOR:.....	34
LOGS.....	34
PARTS LIST / ILLUSTRATION	35
TROUBLESHOOTING	38
STANDING PILOT IGNITION:	38
ELECTRONIC PILOT IGNITION:	40

IMPORTANT SAFETY INFORMATION

IMPORTANT SAFETY INFORMATION:

INSTALLER: Please leave these instructions with the owner.

OWNER: Please read and retains these instructions for future reference.

IMPORTANT: Read these instructions carefully before installing or trying to operate this appliance.

- **DO NOT** use this appliance if any part has been under water. Immediately call a qualified service technician to inspect the appliance and to replace any part of the control system and any gas control, which has been under water.
- The appliance and its individual shutoff valve must be disconnected from the gas supply piping system during any pressure testing of that system at test pressures in excess of 1/2 psig (3.5 kPa).
- The appliance must be isolated from the gas supply piping system by closing its individual manual shutoff valve during any pressure testing of the gas supply piping system at test pressures equal to or less than 1/2 psig (3.5 kPa).
- Installation and repair should be done by a qualified service person.
- This appliance **MUST BE** installed on a metal or wood plate extending the full width and depth of the unit if the unit is to be installed on carpet, vinyl tile or any combustible other than wood.
- **CARBON MONOXIDE POISONING:** Early signs of carbon monoxide poisoning are similar to the flu with headaches, dizziness and/or nausea. If you have these signs, obtain fresh air immediately. Have the appliance serviced, as it may not be operating properly.
- To prevent malfunction and/or sooting, this appliance should be inspected before use and at least annually by a professional service person. More frequent cleaning may be required due to excessive lint from carpeting, bedding materials, etc. It is imperative that control compartments, burners and circulating air passageways of the appliance be kept clean. Refer to **MAINTENANCE** section found in this manual.
- This gas fireplace is a vented gas appliance. **DO NOT** burn wood or other material in this appliance.
- This appliance and vent assembly **MUST** be vented directly to the outside. This appliance **MUST NEVER** be connected to a chimney flue(s) servicing a separate solid-fuel burning appliance or any other appliances.
- This appliance **MUST** use one of the vent systems described in the venting system of this manual. **NO** other vent systems or components may be used.
- Venting terminals **MUST NOT** be recessed into a wall or siding
- Inspect the external vent cap on a regular basis to make sure that no debris is interfering with the airflow.
- Provide adequate clearances around air openings and adequate accessibility clearance for servicing and operation. **NEVER** obstruct front opening of the appliance.
- **DO NOT OPERATE** the appliance with the glass door removed, cracked, or broken. Replacement of the glass door should be done by a licensed or qualified person. **DO NOT** strike or slam the door. The glass door assembly should only be replaced as a complete unit supplied by manufacturer. **NO** substitute materials should be used.
- **DO NOT** use abrasive cleaners on the glass door assembly. Do not clean glass door when it is hot.
- Any safety screen or guard (i.e. glass door) removed for servicing an appliance should be replaced prior to operating the appliance.
- The installation must conform with local codes, or in the absence of local codes, with the National Fuel Gas Code, ANSI Z223.1 (in the United States) or with the current installation code CAN/CGA - B149 (in Canada).
- This unit complies with ANSI Z21.88-98, CGA 2.32-98.
- During manufacturing, fabricating, and shipping, various components of this appliance are treated with certain oils, film, or bonding agents. These chemicals are not harmful but may produce annoying smoke and smells as they are burned off during the initial operation of the appliance; possibly causing headaches or eye and lung irritation. This is a normal and temporary occurrence. The initial break-in operation should last 2-3 hours with the burner at the highest setting. Provide maximum ventilation by opening windows and doors to allow odors to dissipate with continued use.

PRODUCT SPECIFICATIONS/LISTING & CODE APPROVAL

PRODUCT SPECIFICATIONS:

Models Number	Gas Type	Control Type	Max Btu	Gas Pressure (Inches W.C.)		
				Max	Min	Manifold
320DV4136NV	Natural Gas	Milli-volt	26000	10.5	4.0	3.5
320DV4136PV	Propane/LPG	Milli-volt	26000	13.0	11.0	10.0
320DV4742NV	Natural Gas	Milli-volt	28000	10.5	4.0	3.5
320DV4742PV	Propane/LPG	Milli-volt	28000	13.0	11.0	10.0
320DV4136NE	Natural Gas	Electronic Ign	26000	10.5	4.0	3.5
320DV4136PE	Propane/LPG	Electronic Ign	26000	13.0	11.0	10.0
320DV4742NE	Natural Gas	Electronic Ign	28000	10.5	4.0	3.5
320DV4742PE	Propane/LPG	Electronic Ign	28000	13.0	11.0	10.0

High Altitude Installations

Gas rate shown above is for altitudes up to 2000 ft. When installing this fireplace at an elevation above 2000 ft, it may be necessary to decrease the input rating by changing the existing burner orifice to a smaller size. Input should be reduced four percent (4%) for each 1000 ft above sea level, unless the heating value of the gas has been reduced. Consult your local dealer or gas authority for assistance in determining the proper orifice at your location.

LISTING & CODE APPROVAL:

The above models have been tested and certified by the applicable laboratories to the standards listed below.

MODEL	LAB.	TYPE	CERTIFICATION STANDARD
320DV4136 Series	CSA	Vented Gas Fireplace Heaters	ANSI Z21.88-1998•CSA 2.33-M98
320DV4742 Series	CSA	Vented Gas Fireplace Heaters	ANSI Z21.88-1998•CSA 2.33-M98

In addition, this appliance may be installed in an aftermarket, permanently located, manufactured (mobile home, where not prohibited by local codes. This appliance is only for use with the type of gas indicated on the rating plate. This appliance is not convertible for use with other gases, unless a certified kit is used.

PRE-INSTALLATION INFORMATION

PRE-INSTALLATION INFORMATION:

Before You Start:

Read this homeowner manual thoroughly and follow all instructions carefully. Inspect all contents for shipping damage and immediately inform your dealer if any damage is found. **Do not install any unit with damaged, incomplete, or substitute parts.**

Contents:

- Fireplace – Firebox and Burner system
- Fiber Ceramic Logs Set
- Canopy/Hood
- Lava Rock
- Rock Wool
- Restrictor Kit
- Deflector Shield (to be used with Horizontal Termination P/N 985)

Items Required For Installations:

Tools:

Phillips Screwdriver
Hammer
Saw and / or saber saw
Level
Measuring Tape
Electric Drill and Bits
Pliers
Square
Pipe Wrench

Building Supplies:

Framing Materials
Wall Finishing Materials
Caulking Material (Noncombustible)
Fireplace Surround Material (Noncombustible)
Piping Complying with Local Codes
Tee Joint
Pipe Sealant Approved for use with Propane/LPG
(Resistant to Sulfur Compounds)

Fireplace Location:

Plan for the installation of your appliance. This includes determining where the unit is to be installed, the vent configuration to be used, framing and finishing details, and whether any optional accessories (i.e. blower, wall switch, or remote control) are desired. Consult your local building code agency to ensure compliance with local codes, including permits and inspections.

The following factors should be taken into consideration:

- Clearance to side-wall, ceiling, woodwork, and windows. Minimum clearances to combustibles **must be maintained.**
- This fireplace may be installed along a wall, across a corner, or use an exterior chase. Refer to Figure 2 for suggested locations.
- Location should be out of high traffic areas and away from furniture and draperies due to heat from appliance.
- Never obstruct the front opening of the fireplace.
- Do **not** install in the vicinity where gasoline or other flammable liquids may be stored.
- Vent pipe routing. Refer to **Venting** section found in this manual for allowable venting configurations.
- These units can be installed in a bedroom. Refer to National Fuel Gas Code ANSI Z223.1/NFPA 54 - (current edition), the Uniform Mechanical Code - (current edition), and Local Building Codes for specific installation requirements.

PRE-INSTALLATION INFORMATION

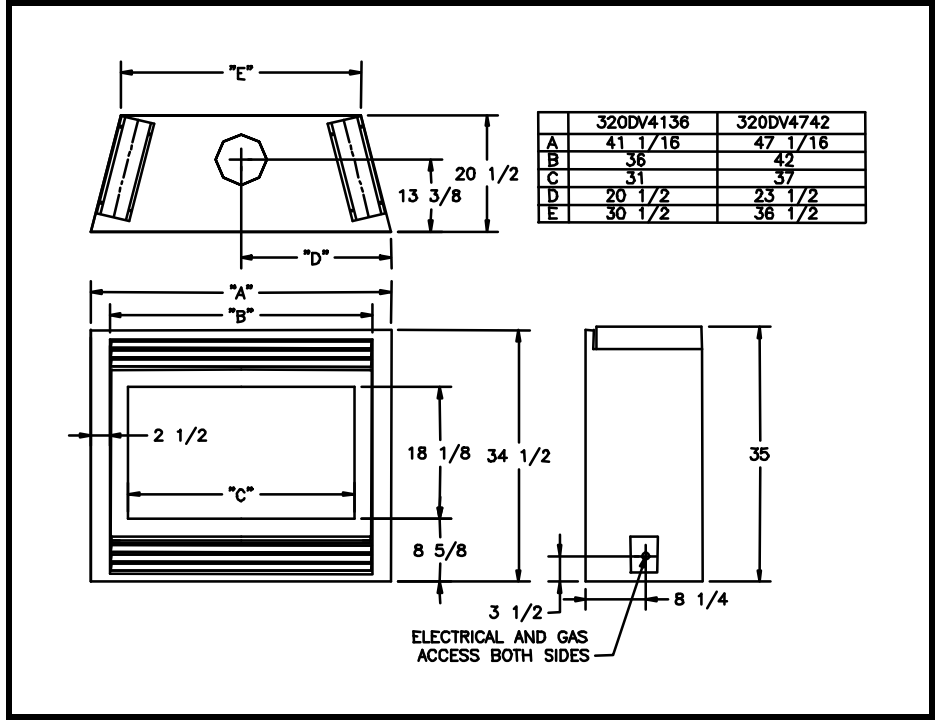

Figure 1: Fireplace Dimensions

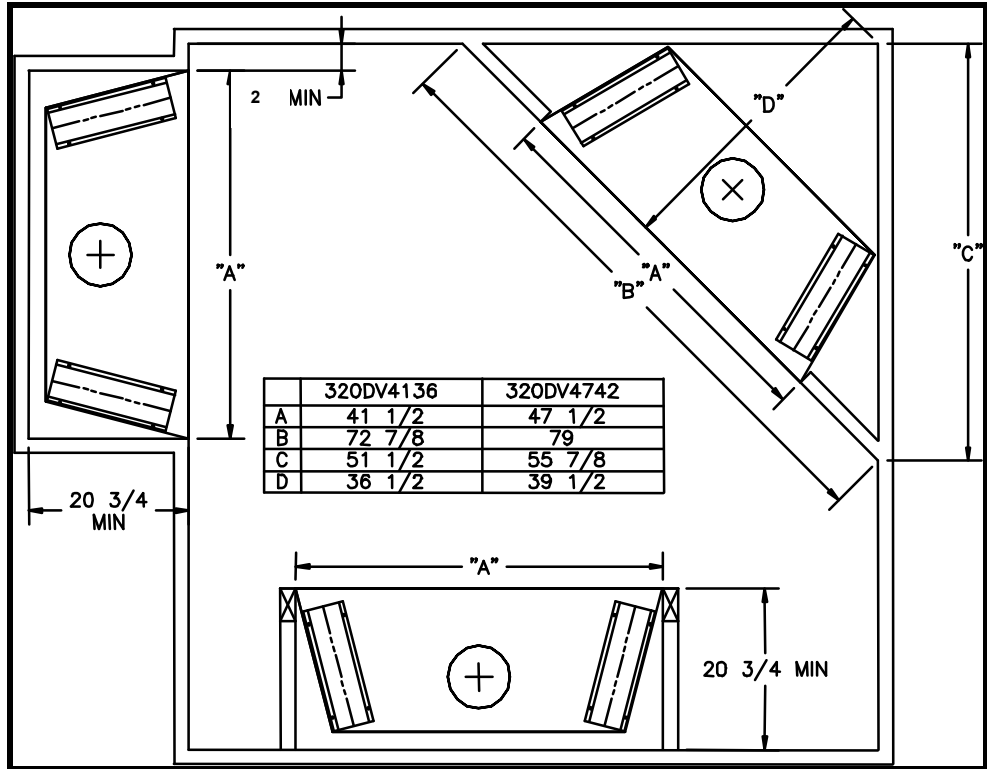

Figure 2: Fireplace Locations and Minimum Clearances Requirements

PRE-INSTALLATION INFORMATION

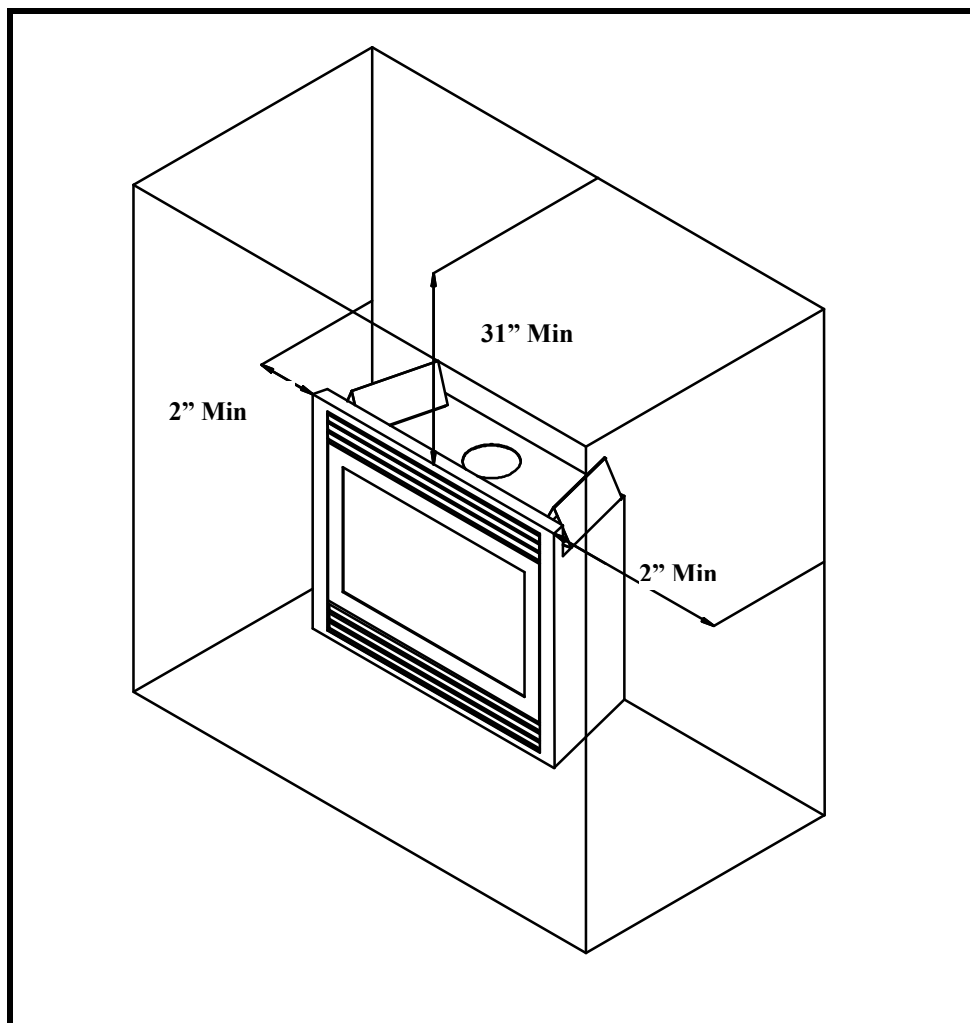

Figure 3: Wall & Ceiling Minimum Clearances

Wall and Ceiling Clearance Requirements:

Ensure that minimum clearance shown in Figures 3 is maintained. Left and right clearances are determined when facing the front of the appliance. Follow these instructions carefully to ensure safe installation. Failure to follow these requirements may create a fire hazard.

Side-wall Clearance: The clearance from the front edge of the appliance to any combustible wall should not be less than 2" on both the left and right side.

Ceiling Clearance: The ceiling must be at least 31" from the top of the front of the fireplace (65.5" from the bottom of the appliance). Refer to Figure 3.

Back-wall Clearance: The appliance may be placed against a combustible back wall. NOTE: There are 1/4" ribs/spacers on the outer shell of the unit to maintain minimum clearance of the outer shell to combustibles.

Combustible Clearances:

The appliance is a zero clearance fireplace with ribs/spacers defining the minimum space to the sheet metal outer shell. Combustibles may be placed up against these spacers. Do **NOT** place combustibles (i.e., insulation, wood, etc.) closer than allowed by the spacers or a fire hazard may exist. The ribs/spacers for the sides and rear of the appliance are 1/4" and the top spacers are 3 1/4". On the front top edge in front of the top framing spacers, a combustible wall (or drywall) may be brought up to the top edge of the unit. Refer to Figure 4.

PRE-INSTALLATION INFORMATION

Mantel Clearances:

A hood/canopy comes with every appliance. If a combustible mantel is installed, it must meet the clearance requirements detailed in Figure 4.

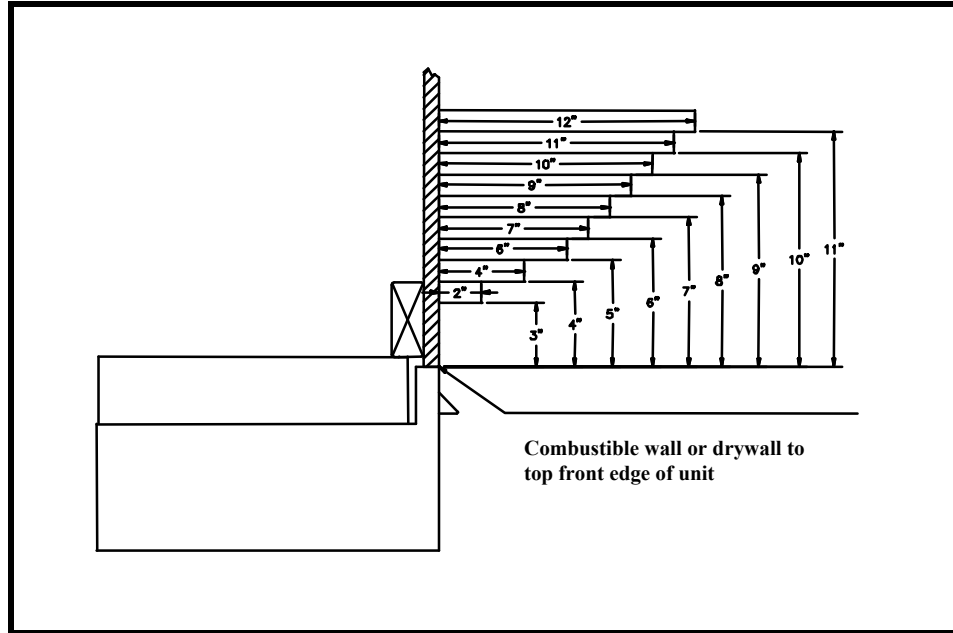

Figure 4: Mantel Clearance

Floor Clearances:

The fireplace may be installed on a flat, hard combustible surface (i.e. flat wood, plywood, or particleboard). Be sure that the fireplace rests on a solid continuous floor of platform with appropriate framing support. Do **NOT** install appliance directly on carpeting, vinyl, or other soft floor covering. If the fireplace is to be installed on carpeting or tile, or on any combustible material other than wood flooring, the fireplace should be installed on a metal or wood panel that extends the full width and depth of the fireplace.

Minimum Vent Clearances to Combustible Materials:

The minimum clearances to combustibles for vent pipe require 3 inches at the top and 1 inch at the sides and bottom for horizontal sections of the vent system. Refer to the figure below. For wall or ceiling firestops and vertical sections of vent pipe a 1-inch minimum clearance all around the pipe must be maintained.

On some installation, if the distance between the first elbow and combustible material is three (3) inches, a heat shield is required. This part can be obtained from Monessen or constructed out of steel material to maintain half-inch (1/2") air gap between the pipe and combustible material. The size of the part must be at least 12" wide by 12" long. Refer to figure below.

PRE-INSTALLATION INFORMATION

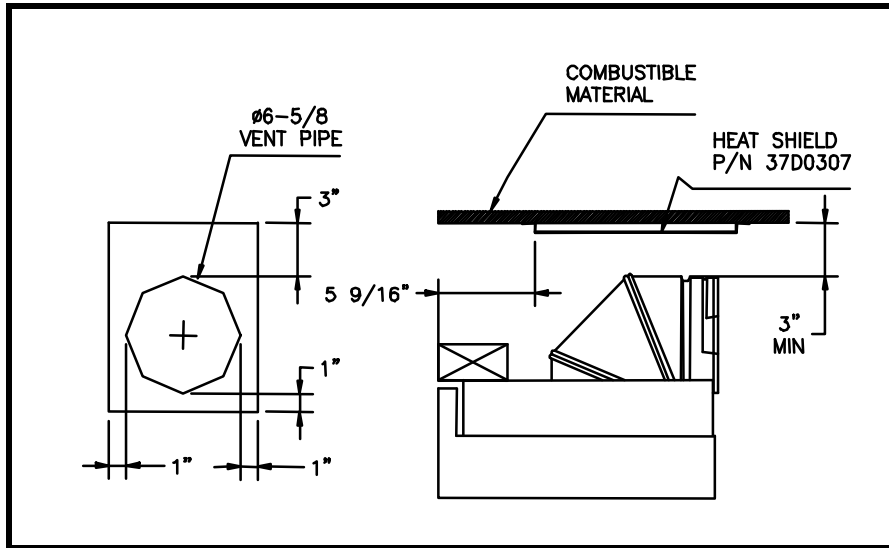

Figure 5: Combustible Clearances for Vent Pipe

Framing Dimensions:

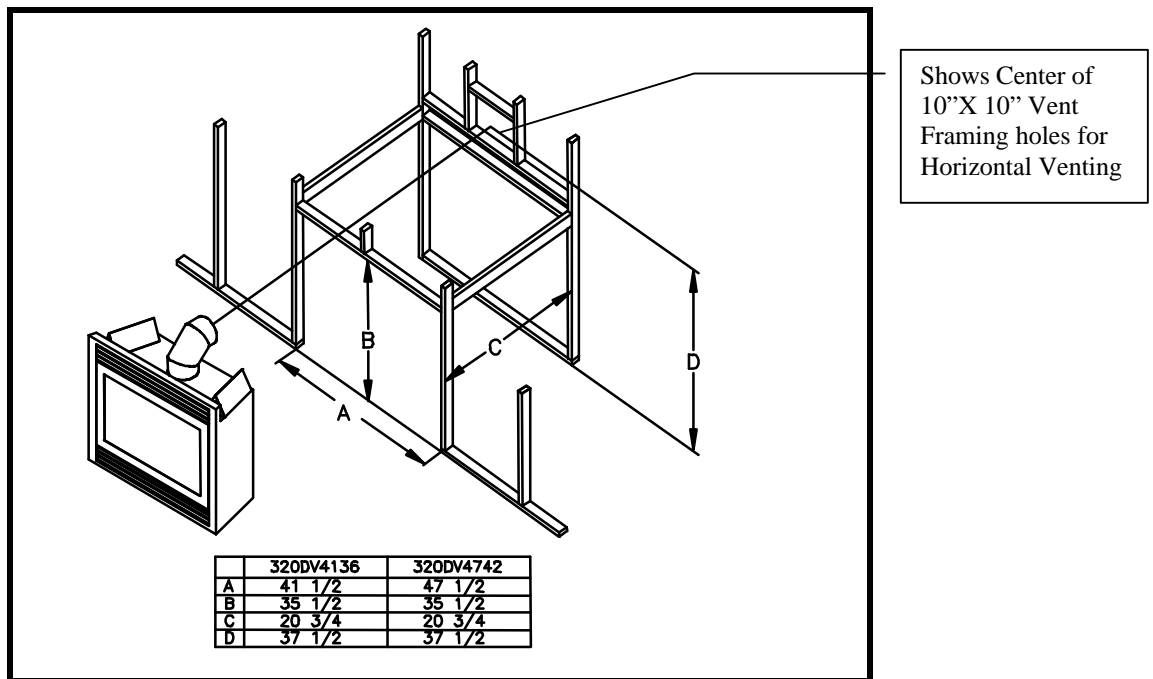

Figure 6: Minimum Framing Dimensions

Firebox framing can be built before or after the appliance is set in place. Framing should be positioned to accommodate wall covering and fireplace facing mantel. Figure 6 shows a typical framing of this appliance. Refer to Figure 1 for firebox dimensions. All minimum clearances must be maintained in framing the appliance. The framing headers may rest on the top of the framing spacers.

CAUTION
Measure fireplace dimensions and verify framing methods & wall covering details before framing construction begins.

PRE-INSTALLATION INFORMATION

Finishing Material:

NOTE

Any remote wiring (i.e. remote control, wall switch, and optional fan) must be done prior to final finishing to avoid costly reconstruction.

WARNING

Never obstruct or modify the air inlet or outlet grills (louvers) in any manner as it may create a fire hazard.

Only noncombustible materials (i.e. brick, tile, slate, steel, or other materials with a UL fire rating of Zero) may be used to cover the black surface of the appliance. A 300°F minimum adhesive may be used to attach facing materials to the black surface. If joints between the finished wall and the fireplace surround are sealed, a 300° F minimum sealant material (General Electric RTV103 or equivalent) must be used. Refer to Figure 7.

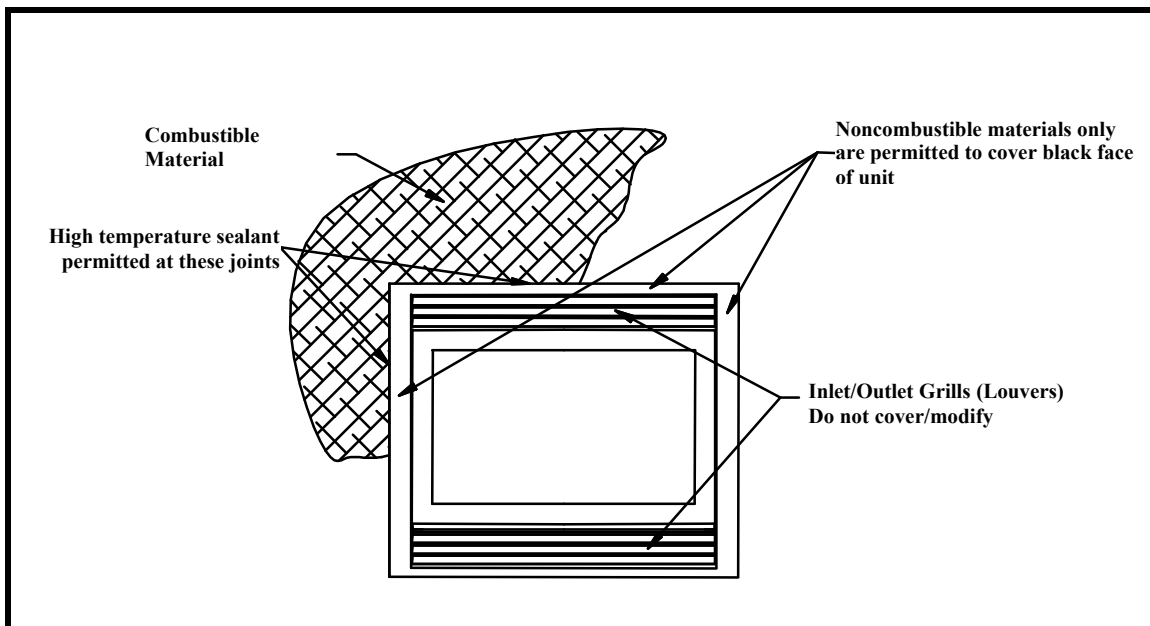

Figure 7: Finishing Material

VENT INSTALLATION

VENT INSTALLATION:

Positioning The Fireplace:

NOTE

The fireplace must be installed giving full consideration to the clearance and height requirements identified in this manual.

1. Bend out the six (6) nailing flanges located on the sides and top of the fireplace
2. Slide the firebox into prepared framing or position fireplace in its final position and frame later. Be sure fireplace is rested on a flat surface.
3. Level the fireplace by checking the top of unit. Shim side-to-side and front-to-back as necessary.
4. Anchor nailing flanges of the fireplace to the side-framing members using 8d nails or other suitable fasteners.

Venting Configuration:

These models are approved to use Simpson-Duravent 4 X 6-5/8 Direct Vent Pipe Components and Monessen Hearth System termination kits. **No other venting systems or components may be used.** See **PARTS LIST / ILLUSTRATIONS** section for a list of approved vent components.

WARNING

Any common venting of this gas appliance with other gas appliances is not allowed. Do not connect this appliance to a chimney flue servicing a separate solid fuel-burning appliance.

Venting Vertical Straight Up (No Elbow):

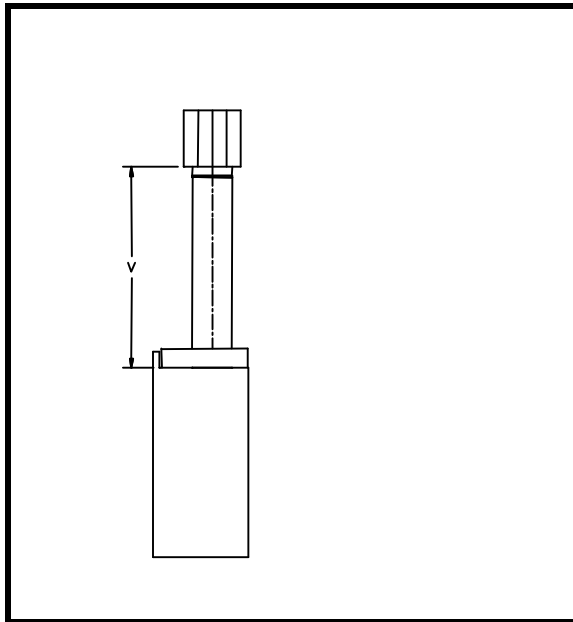

Dim	Min	Max
V	6 feet	40 feet

NOTE

Air Restrictor Kit is recommended for vertical runs of 10 feet or more to improve flame appearance. This kit can be found in the homeowner manual packet assembly.

Figure 8: Vertical Venting - Straight Up

VENT INSTALLATION

Horizontal Venting with One (1) Elbow:

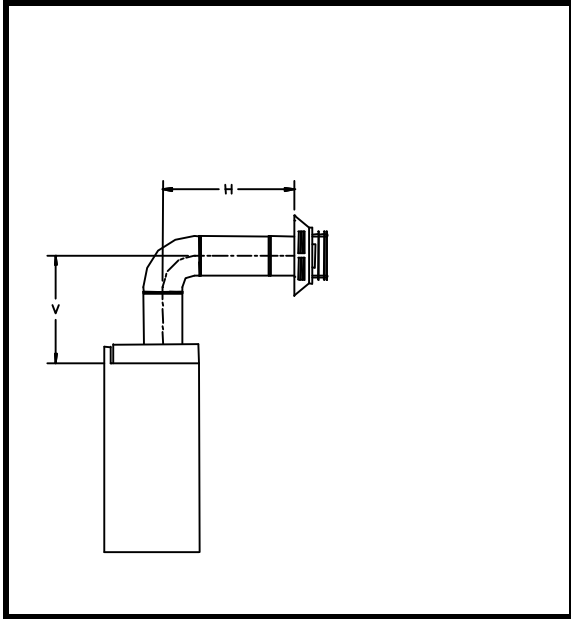

V, Vertical	H, Horizontal
Elbow (5 inches)	30 inches Max
Elbow (5 inches)	30 inches Corner Max
1 foot Min	5 feet Max
2 feet Min	10 feet Max
3 feet Min	15 feet Max
4 feet Min	20 feet Max

NOTE
If a 90° Elbow is first attached to the unit, the maximum horizontal run, H, is 30 inches straight out, and 30 inches at a corner installation.

Figure 9: Horizontal Venting with One (1) Elbow

Vertical Venting with Two (2) Elbows:

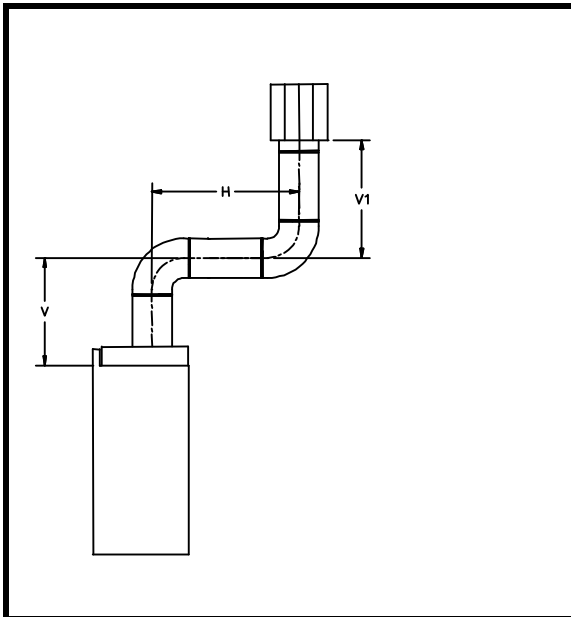

V, Vertical	H, Horizontal
1 foot Min	5 feet Max
2 feet Min	10 feet Max
3 feet Min	15 feet Max
4 feet Min	20 feet Max

NOTE
**V1 dimension must satisfy this condition:
 $V + H + V1 < 40$ feet.**

Figure 10: Vertical Venting with Two (2) Elbows

VENT INSTALLATION

Horizontal Venting with Three (3) Elbows:

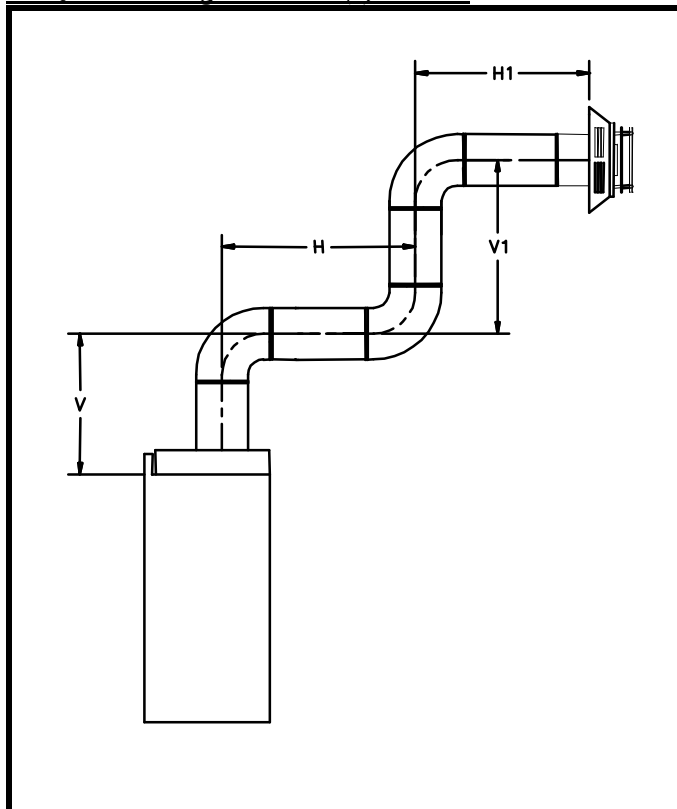

V, Vertical	H, Horizontal
1 foot Min	5 feet Max
2 feet Min	10 feet Max
3 feet Min	15 feet Max
4 feet Min	20 feet Max

NOTE
H1 and V1 dimension must satisfy these two conditions:
 $H + H1 < 20$ feet
 $V + H + V1 < 40$ feet.

Figure 11: Horizontal Venting with Three (3) Elbows

INSTALLING VENT COMPONENTS

Before You Start:

Plan your installation. Set unit in place and survey how best to vent the unit. Select the appropriate pipe for the installation. Read this manual and the manual with the termination cap thoroughly before installing unit or vent system. After vent configuration has been decided, begin attaching pipe to unit.

Piping Installations:

1. Remove the cover plate on top of the fireplace using a Philips screwdriver.
2. Attached the first piece piping (elbow or straight pipe) to the pipe connector located inside the fireplace. All vent pipes will lock into place by sliding the sections together. Nest the 4 indentations on the female end of one pipe into the slots of the pipe connector and then twist the pipe together (Refer to the instructions that comes with termination for more detailed explanation).
3. Continue to add vent components. Be certain that each section is locked properly.
4. Where necessary add support brackets. Refer to the figure below. Horizontal runs must be supported every 3 feet using wall straps (P/N 988). Vertical runs must be supported every 8 feet using wall straps (P/N 988). Slip wall straps loosely on to pipe. Attach straps to framing members using nails or screws. Tighten nut/bolt to secure pipe.

VENT INSTALLATION

NOTE

Two 45° elbows (P/N 945) may be used in place of one 90° elbow (P/N 990).

WARNING

Any horizontal run must have a 1/4" rise for every one (1) foot of run towards the vent termination. Never allow the vent to run downward. This could cause high temperatures and may present a fire hazard.

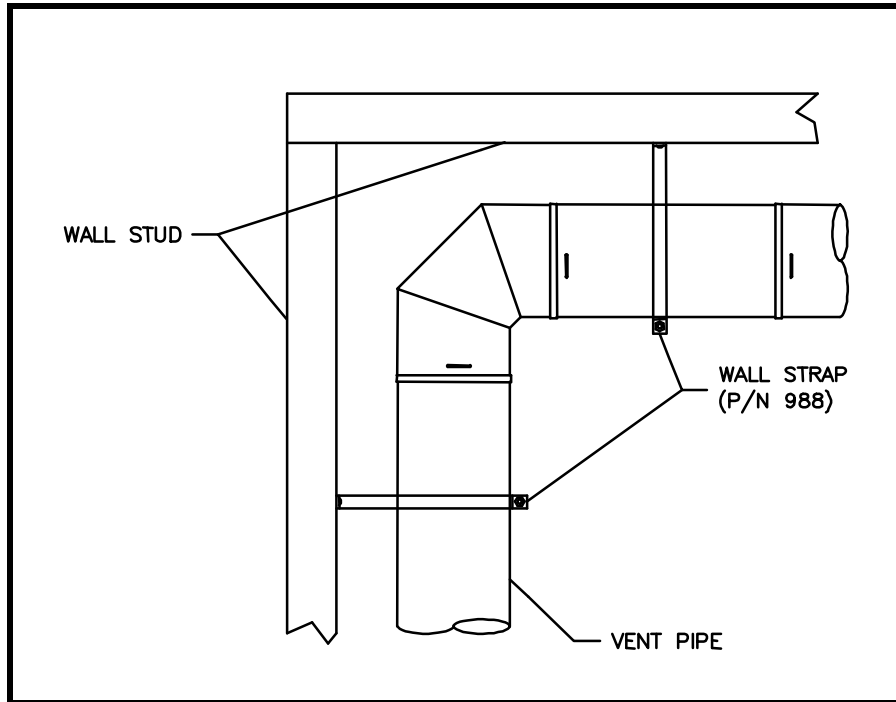

Figure 12: Installing Pipe Supports

WARNING

Always maintain minimum clearances around vent systems. The minimum clearances to combustibles for vent pipe require 3 inches at the top and 1 inch at the sides and bottom for horizontal sections of the vent system. For wall or ceiling firestops and vertical sections of vent pipe a 1-inch minimum clearance all around the pipe must be maintained. Do not pack the open air spaces with insulation or other materials. This could cause high temperatures and may present a fire hazard.

5. A wall or ceiling firestop (P/N 963) **MUST BE** installed if the vent passes through a wall or ceiling.
For wall
 - Cut a 10-inch X 10-inch hole through the interior or exterior wall. The center of the hole is the centerline of the horizontal pipe. Refer to the figure below.
 - Position the firestop on the hole previously cut and secure with screws or nails.
 - Run vent through firestop.

VENT INSTALLATION

For Ceiling

- For ceiling firestops, position a plumb bob over the center of the vertical pipe; to spot a hole through which the pipe will penetrate.
- Drill a hole through this centerpoint and check the floor for obstructions (i.e. wiring or plumbing).
- Reposition the fireplace and vent system, if necessary, to accommodate ceiling joists or obstructions.
- Cut a 10-inch by 10-inch hole through the ceiling, using the center point.
- Frame the hole with framing lumber the same size as the ceiling joists. Refer to the figure below. Position firestop as shown in the figure below. If attic is above, mount firestop on top of framing. If room is above, mount firestop on the bottom of framing. Secure with nails or screws.
- Run vent through firestop.

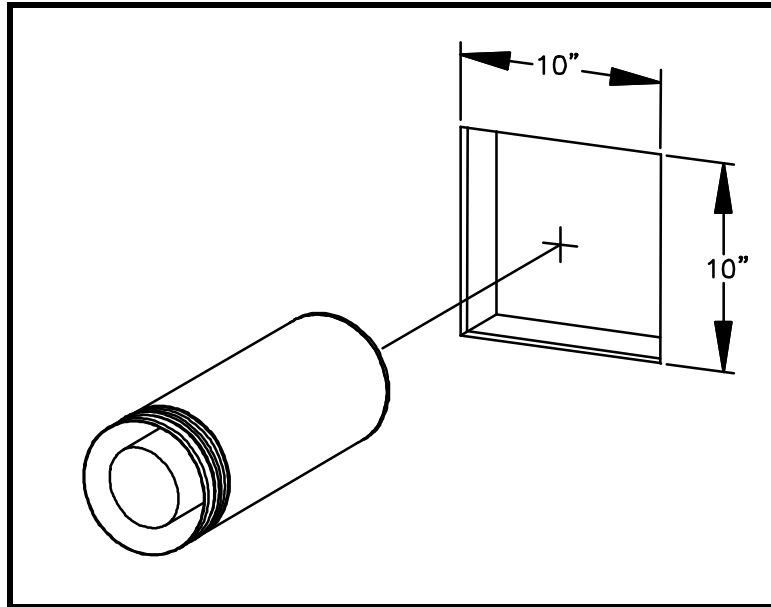

Figure 13: Wall Firestop Location

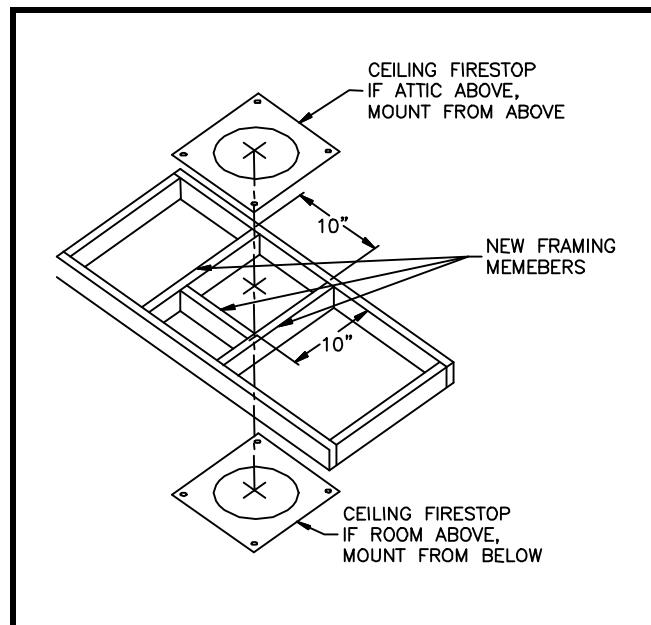

Figure 14: Ceiling Firestop Location

VENT INSTALLATION

Vent Termination:

For Vertical Termination

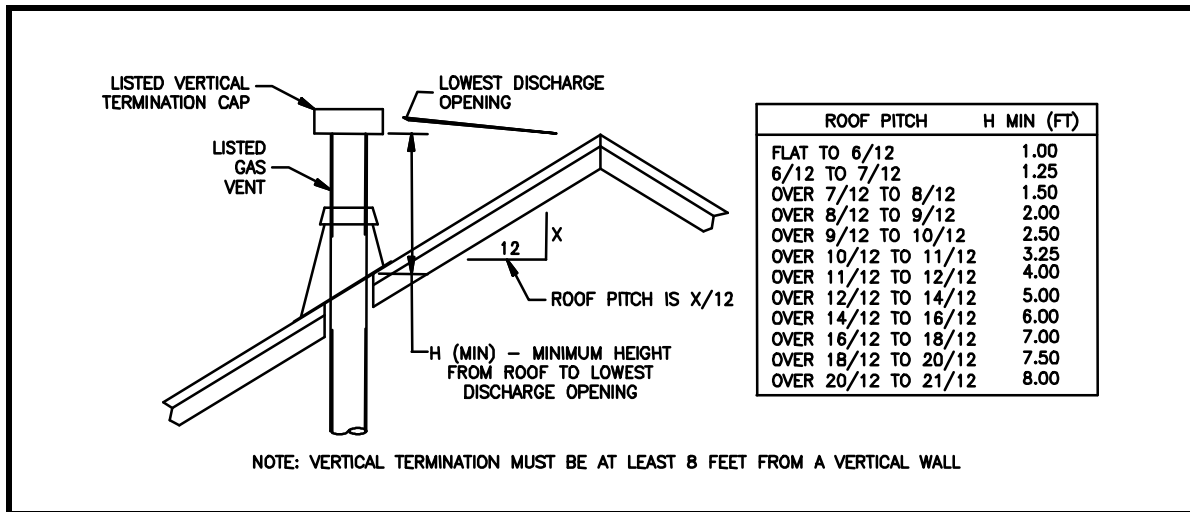

Figure 15: Minimum Vent Height for Various Roof Pitches

WARNING

Major building codes specify a minimum vent height above the rooftop depending on the pitch of the roof. Refer to the above figure for minimum heights, provided the termination cap is at least eight (8) feet from a vertical wall, and two (2) feet below a horizontal overhang. Trees, buildings, adjoining roof lines, & adverse wind conditions may require taller chimneys than what is shown in the figure below.

NOTE

When working on the roof, cover the opening of the installed vent pipes below to prevent debris falling in.

WARNING

Always maintain minimum clearances around vent systems. For ceiling firestops and vertical sections of vent pipe a 1-inch minimum clearance all around the pipe must be maintained. Do not pack the open air spaces with insulation or other materials. This could cause high temperatures and may present a fire hazard.

To locate and install vertical termination

- Locate and mark the vent centerpoint on the underside of the roof, and drive a nail through the centerpoint.
- The size of the roof hole framing dimensions depends on the pitch of the roof
- Cut and frame the roof hole.
- Continue to install vent sections through the roof hole until reaching the appropriate distance above the roof.
- Attach a flashing (P/N 943) to the roof using nails, and use a non-hardening mastic around the edges of the flashing base when it meets the roof.
- Attach a storm collar (P/N 953) over the flashing joint to form a watertight seal. Place non-hardening mastic around the joint, between the storm collar and the vertical pipe.
- Slide the vertical termination cap (P/N 980) over the end of the pipe. At least 1 1/2" of overlap is required. Screw the termination to the pipe with three (3) screws.

VENT INSTALLATION

For Horizontal Termination

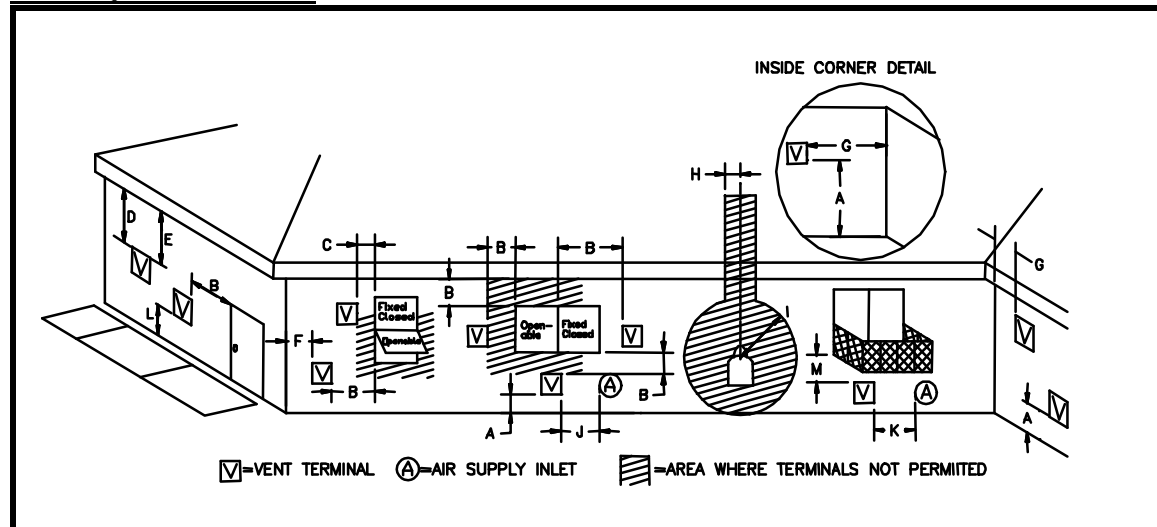

Figure 16: Horizontal Vent Termination Location

#	A=12 inches	Clearance above the grade, a veranda, porch, deck, or balcony
#	B=12 inches	Clearance to window or door that may be opened.
	C=12 inches	Clearance to permanently closed window.
	D*=18 inches	Vertical clearance to ventilated soffit located above the terminal within a horizontal distance of 2 feet from the centerline of the terminal.
	E*=18 inches	Clearance to unventilated soffits.
	F=9 inches	Clearance to an outside corner.
	G=6 inches	Clearance to an inside corner.
#	H=3 feet	Not to be installed above a gas meter/regulator assembly within 3 feet horizontally from the centerline of the regulator.
#	I=6 feet	Clearance to service regulator vent outlet.
#	J=12 inches	Clearance to non-mechanical air supply inlet to building or the combustion air inlet to any other appliance.
#	K=6 feet	Clearance to a mechanical air supply inlet
#	L**=7 feet	Clearance above a paved sidewalk paved driveway located on public property.
#	M***=12 inches	Clearance under veranda, porch, deck, or balcony.
	#	As specified in CGA B149 Installation Codes. Note: Local codes or regulations may require different clearances.
	*	30" minimum for vinyl clad soffits
	**	A vent must not terminate directly above a sidewalk or paved driveway, which is located between two single-family dwellings and serves both dwellings.
	***	Only permitted if veranda, porch, deck, or balcony is fully open on a minimum of 2 sides beneath the floor.

VENT INSTALLATION

WARNING

Always maintain minimum clearances around vent systems. The minimum clearances to combustibles for horizontal vent pipe are 3 inches at the top and 1 inch at the sides and bottom of the vent system. For wall firestops, a 1-inch minimum clearance all around the pipe must be maintained. Do not pack the open air spaces with insulation or other materials. This could cause high temperatures and may present a fire hazard. Any horizontal run must have a 1/4" rise for every one (1) foot of run towards the vent termination. Never allow the vent to run downward. This could cause high temperatures and may present a fire hazard.

WARNING

Termination cap must be positioned so that the embossed arrow is pointed up.

WARNING

Horizontal High Wind Termination Cap (P/N 985) or Horizontal Termination Cap (HTC) must be used for all horizontal termination application to ensure proper operation of pilot and burner systems.

WARNING

A deflector shield **MUST BE** installed on termination cap. Failure to comply may cause heat damage or sooting to wall.

To locate and install horizontal high wind termination cap (P/N 985)

- A deflector shield (P/N 37D0115) must be installed on horizontal high wind termination cap (P/N 985). The deflector shield is included in the homeowner manual packet assembly. Failure to comply may cause heat damage or sooting to wall. Attach the deflector shield to the using the two screws provided.
- If the house has vinyl siding, a vinyl siding standoff (P/N 950) must be used. Using the same cut-out hole on the wall for wall firestop, align the vinyl siding with the hole, and then mark and cut the vinyl siding so that the vinyl siding standoff can be mounted flush to the wall. Secure the standoff with galvanized, rustproof nails or screws. Finish the edges of the siding with trim or "J channel" to prevent water from leaking into the building.
- Slide the horizontal high wind termination cap (P/N 985) over the end of the pipe. (Through the vinyl siding standoff if installed) At least 1 1/2" of overlap is required. Screw the termination to the pipe with three (3) screws.
- Attach the termination to the exterior wall or to the vinyl siding standoff (if installed) using four (4) screws provided in the termination box.

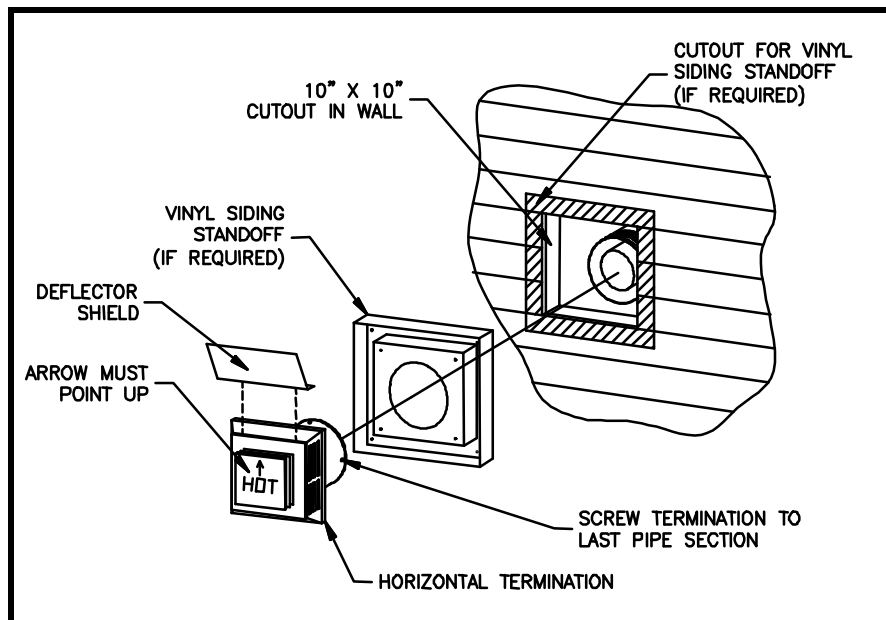

Figure 17: Horizontal High Wind Termination (P/N 985) Installation on a Vinyl Siding Wall

VENT INSTALLATION

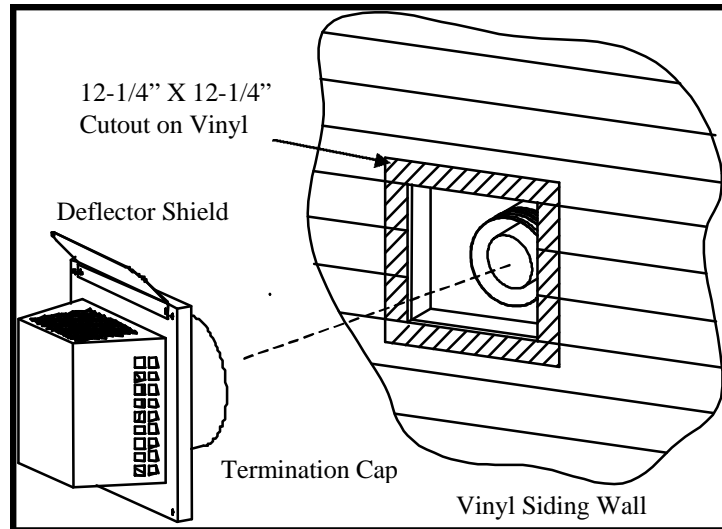

Figure 18 Horizontal Termination Cap on a Vinyl Siding Wall

To locate and install horizontal termination cap (P/N HTC)

- A wall firestop **MUST BE** installed if the vent passes through a wall or ceiling. Cut a 10-inch X 10-inch hole through the interior or exterior wall. The center of the hole is the centerline of the horizontal pipe. Position the firestop on the hole previously cut and secure with screws or nails (not provided). Run vent through firestop.
- Attach and secure the termination to the last section of the adjustable pipe. The termination cap should pass through the wall firestop from the exterior of the building. Make sure the termination cap is installed following the arrow direction. The termination cap slides onto the last vent section with at least of 1-1/2" overlap and is fastened with a minimum of three (3) #8 X 5/8" sheet metal screws. Drive these screws through the outer pipe of the termination cap and through the outer pipe of the last vent pipe section.
- Attach the deflector shield to the termination cap with the two (2) #6 X 1/2" screws provided as shown in Figure 18.
- If the house has vinyl siding, mark and cut the vinyl siding 12-1/4" X 12-1/4" square center around the pipe so that the termination cap can be mounted flush to the wall. Finish the edges of the siding with trim or "J channel" and caulking to prevent water from leaking into the building.
- Attach the termination cap to the exterior wall using four (4) #8 X 3" screws provided.

GAS LINE AND ELECTRICAL INSTALLATION

GAS LINE AND ELECTRICAL

Gas Line Installation:

NOTE

Plumbing connections should only be performed by a qualified, licensed plumber. Main gas supply must be off when plumbing gas line to fireplace or performing service.

- Consult all codes. All gas piping must be installed to comply with local codes, or in the absence of local codes, with the latest edition of the *National Fuel Gas Code ANSI Z223.1*.
- This appliance and its individual shutoff valve must be disconnected from the gas supply piping system during any pressure testing of that system at test pressure in excess of 1/2 psi (3.5 kPa).
- The appliance must be isolated from the gas supply piping system by closing its individual manual shutoff valve during any pressure testing of the gas supply piping system at test pressure equal to or less than 1/2 psi (3.5 kPa).
- Use new black iron or steel pipe. Internally tinned copper or copper tubing can be used per *National Fuel Gas Code, section 2.6.3*, providing gas meets sulfide limits, and where permitted by local codes.
- An ANSI approved 1/8" NPT pressure tapping point must be installed immediately upstream of the gas supply connection to the fireplace
- A sediment trap may be install upstream of the fireplace to prevent moisture and contaminants from passing through to the fireplace control and burner. Failure to do so could prevent appliance from operating reliably.
- On some local codes, the gas line must be connected to a gas shut-off valve recessed flush into the wall or floor outside the fireplace. The valve should be controlled by a removable valve key for safety. In this case, remove the shut-off valve from the flex line and installed direct to stub.

WARNING

Support the shut-off valve when attaching 1/2" gas line. Use a wrench to hold shut-off valve stationary. Do not twist the flex line when tightening the 1/2" gas line.

WARNING

Connecting directly to an unregulated propane/L.P.G. tank can cause an explosion. An external regulator must be used on all propane/LPG appliances to reduce the supply tank pressure to 13" w.c. (maximum).

WARNING

Do not connect directly to natural gas 1/2- psi or 2-psi systems. Always make sure the natural gas pressure is regulate to 10.5 w.c. (maximum) before operating the unit.

1. Check gas type. The gas supply must be the same as stated on the appliance's rating decal. If the gas supply is different from the fireplace, **STOP! Do not install the appliance.** Contact your dealer immediately.
2. To ease installation, a 30" flex line with manual shut-off valve has been installed on this fireplace. Install 1/2" gas line onto shut-off valve.
3. Locate the gas line access hole in the outer casing of the fireplace. Remove the screw on the gas line cover plate. Open the fireplace door, insert the gas supply line through the knock out hole on the gas line cover plate, and connect it to the shut-off valve.
4. After completing gas line connection, purge air from gas line and test all gas joints from the gas meter to the fireplace for leaks. Use a soap and water solution or a gas sniffer.
5. To check gas pressure at valve, turn captured screw counter clockwise 2 or 3 turns and then place tubing to pressure gauge over test point. Refer to Figure 19: Gas Pressure Check at Gas Valve. After taking pressure reading, be sure and turn captured screw clockwise firmly to re-seal. Do not over torque. Check for gas leaks.

WARNING

Do not use open flame to check for gas leaks.

GAS LINE AND ELECTRICAL INSTALLATION

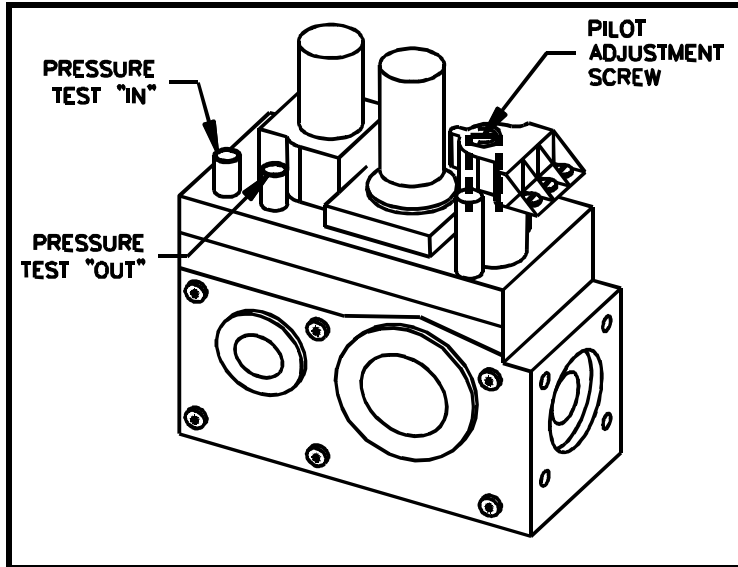

Figure 19: Gas Pressure Check at Gas Valve

Electrical Wiring:

CAUTION

Electrical connections should only be performed by a qualified, licensed electrician. Main power must be off when connecting to main electrical power supply or performing service. All wiring shall be in compliance with all local, city, and state codes. The appliance, when installed, must be electrically grounded in accordance with local codes, or in the absence of local codes, with the *National Electrical Code ANSI / NFPA 70 (latest edition)*

Label all wires prior to disconnection when servicing controls. Wiring errors can cause improper and dangerous operations. Verify proper operation after servicing.

Standing Pilot Ignition Wiring-Millivolt Control:

WARNING

Do not connect 110-120 VAC to the Remote Wall Switch, DC Remote Control or the Millivolt Control Valve. The appliance will malfunction or the valve will be destroyed.

Remote Wall Switch

A remote wall switch and fifteen (15) feet of 18 Ga. wire are provided as standard with this fireplace. The wire has been pre-wired at the valve and routed through the right side, outer shell. (Access is also available on the left side through the square hole on that side). Position the wall switch inside of a junction box (not provided) at the desired location on the wall. Refer to Figure 20: Wiring Diagram for Standing Pilot - Millivolt System. Do not extend beyond the wall switch wire length provided.

NOTE

Extended lengths of wire may cause the fireplace not to function properly. Longer length of wire is permitted if the wire is made out of larger gauge (diameter) wire. Always check with local code

GAS LINE AND ELECTRICAL INSTALLATION

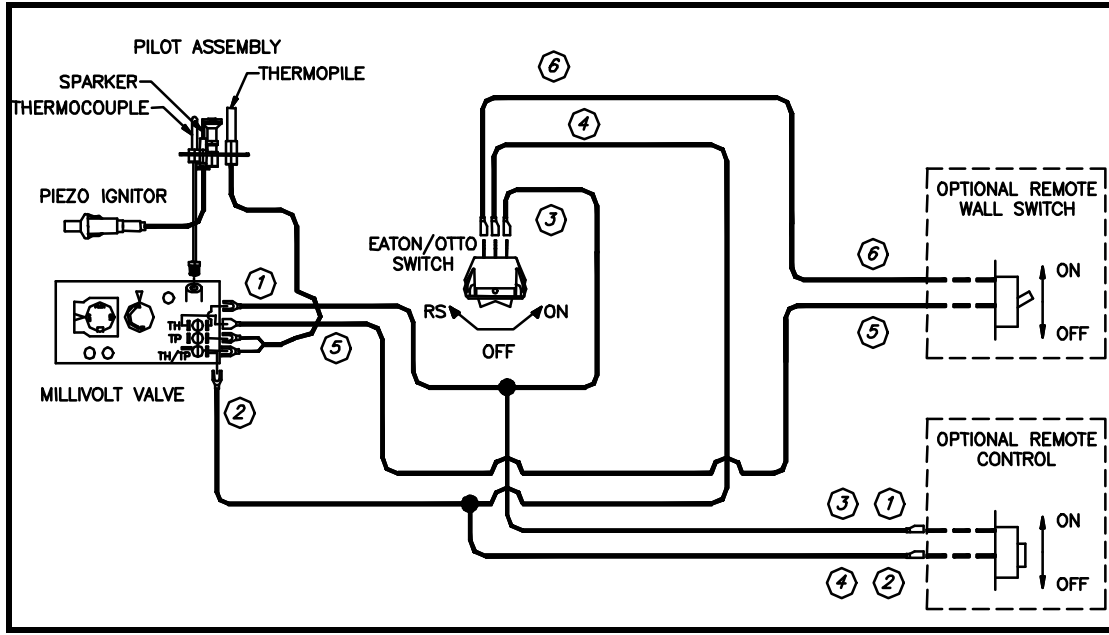

Figure 20: Wiring Diagram for Standing Pilot - Millivolt System

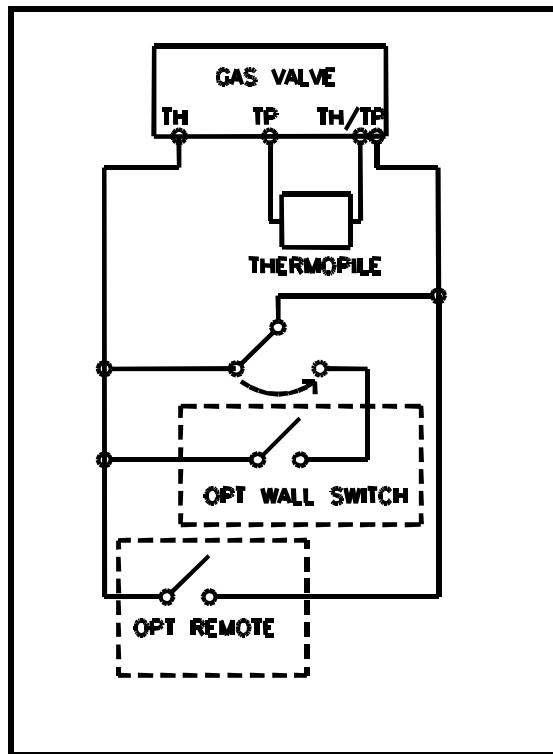

Figure 21: Schematic Diagram for Millivolt System

GAS LINE AND ELECTRICAL INSTALLATION

Optional Fan/Blower Systems

The junction box for the fan/blower systems has been factory installed. This system requires that 110-120 VAC to be wired to the factory installed junction box before the fireplace is permanently installed. Refer to the figures below for wiring or schematic diagram.

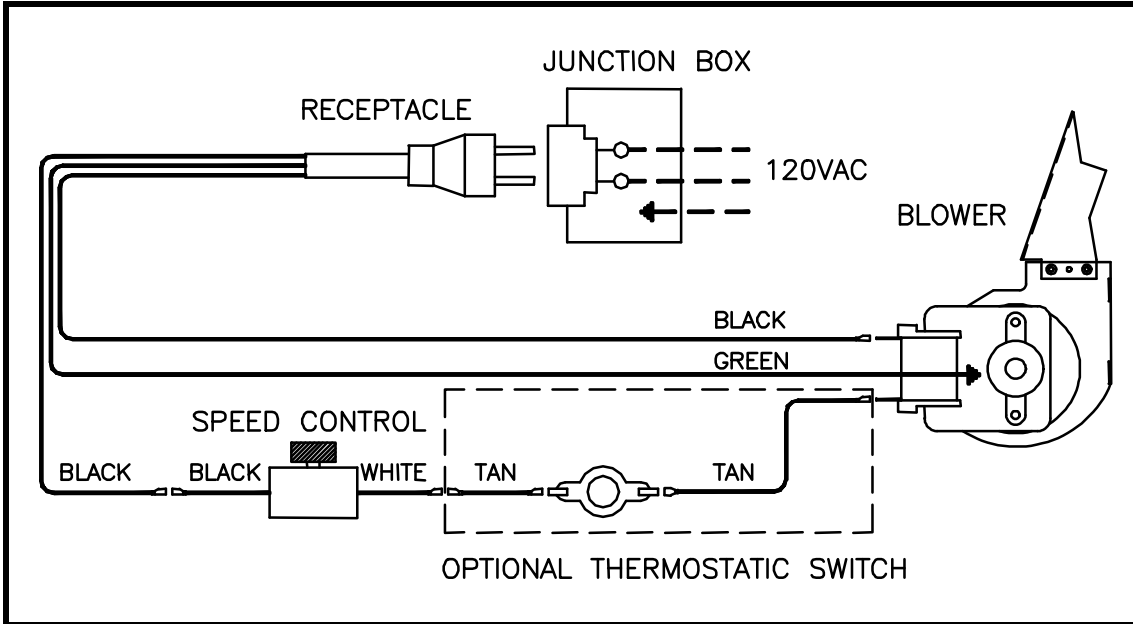

Figure 22: Blower Wiring Diagram

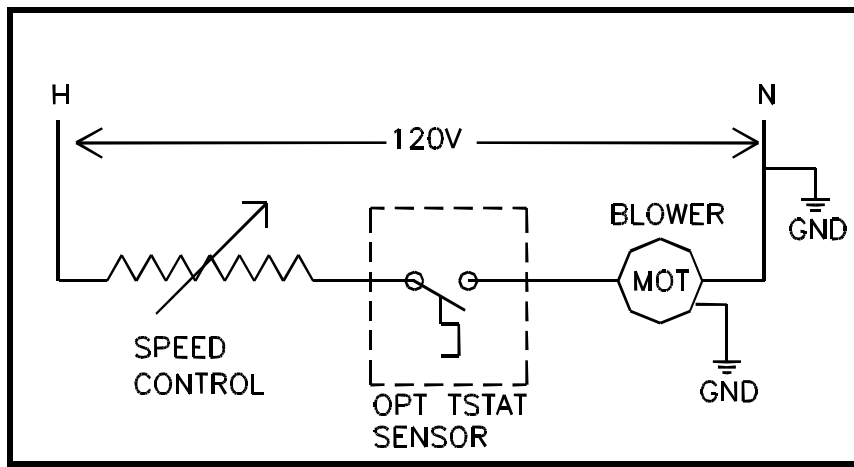

Figure 23: Schematic Diagram for Blower

GAS LINE AND ELECTRICAL INSTALLATION

Optional DC Remote Systems

These instructions supersede the section entitled “Hearth Mount” in the Millivolt hand held remote instructions supplied with the remote.

1. Cut cable to length (approximately 12”) for placement in the fireplace.
2. Strip back 1/4” of the insulation from both ends of each wire.
3. Connect two 1/4” female connectors to the wires at one ends of the wire.
4. Insert the opposite ends of the wires into receiver wire terminals and tighten the screws.
5. Connect the connectors to the two 1/4” male terminals located near the gas valve as shown in Figure 20: Wiring Diagram for Standing Pilot - Millivolt System.
6. Stick velcro pads with self-adhesive backing to bottom of remote receiver and to the floor of the fireplace behind the door with control switch facing towards the room.

NOTE

Heat reduces battery life. You can protect receiver and extend battery life by mounting the receiver in a wall or other location outside the fireplace.

Millivolt Control Valve Checklist:

The millivolt (thermopile) control is a self-powered combustion gas control. Refer to Figure 20: Wiring Diagram for Standing Pilot - Millivolt System. The millivolt system and individual components may be checked with a millivolt meter having 1-1000 mV range. Conduct each check listed below by connecting the meter test leads to the terminals indicated. Refer to **OPERATING INSTRUCTIONS** for safety and lighting instructions.

Thermopile Output Check

Pilot must be lit and the valve control knob turned to the “PILOT” or “ON” position. “RS-ON-OFF” switch must be in the “OFF” position. Meter leads must be connected to the TP and the TH/TP terminals on the control valve. If the meter reading is not 325-millivolt minimum, then readjust pilot for maximum millivolt output. If millivolt reading is still below minimum specified, replace the thermopile.

Thermocouple Output Check

Disconnect thermocouple from valve. Place one lead from meter on the tip of the thermocouple and the other on the thermocouple copper lead. Turn the valve control knob to “PILOT” and hold the valve knob in. Start the pilot and read the millivolt output. If the meter reading is not 15-millivolt minimum, then readjust pilot for maximum millivolt output. If millivolt reading is still below minimum specified, replace the thermocouple.

Complete Millivolt System Check

Pilot must be lit and the valve control knob turned to the “ON” position. Meter leads must be connected to the TP and the TH/TP terminals on the control valve.

- Turn RS-ON-OFF switch to the “ON” position.
 - ✓ If meter is reading more than 100 millivolt and the main burners do not come on, then replace control valve.
 - ✓ If meter is reading less than 100 millivolt, then refer to **TROUBLESHOOTING** section of this manual to determine the cause of the low reading.
- Turn RS-ON-OFF switch to the “RS ” position and wall switch to “ON”
 - ✓ If meter is reading more than 100 millivolt and the main burners do not come on, then replace control valve.
 - ✓ If meter is reading less than 100 millivolt, then refer to **TROUBLESHOOTING** section of this manual to determine the cause of the low reading.

GAS LINE AND ELECTRICAL INSTALLATION

Electronic Pilot Ignition Wiring:

WARNING
Do not connect 110-120 VAC to the Remote Wall Switch. The appliance will malfunction or destroyed.

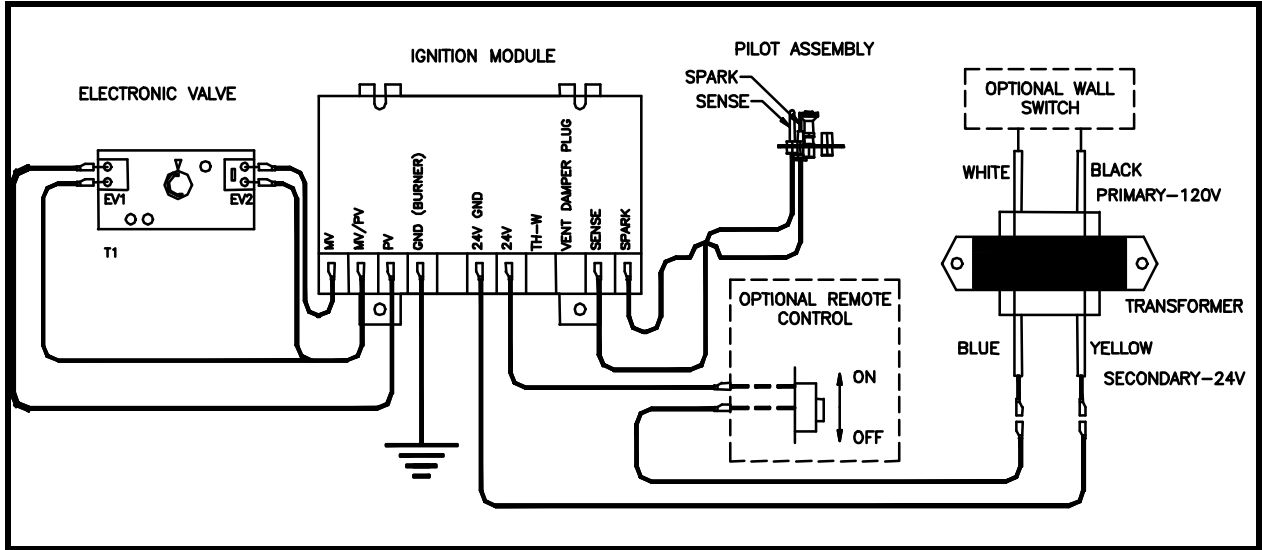

Figure 24: Wiring Diagram for Electronic Ignition

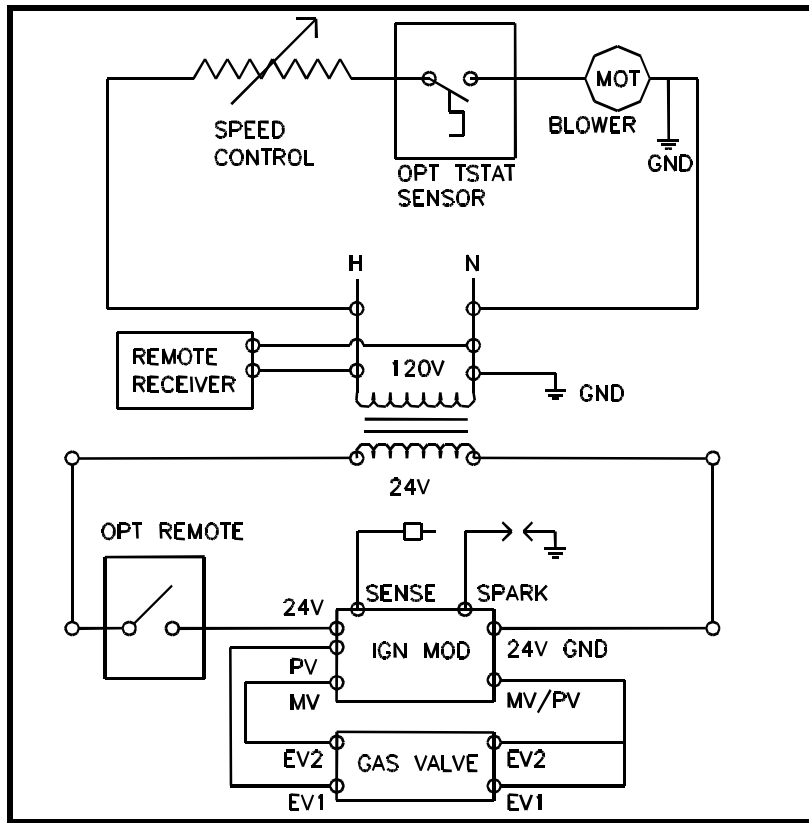

Figure 25: Schematic Diagram for Electronic Ignition and Blower System

GAS LINE AND ELECTRICAL INSTALLATION

Remote Wall Switch

Position the wall switch. Refer to Figure 24: Wiring Diagram for Electronic Ignition. Do not extend beyond the 15 feet of wire.

Optional Fan/Blower Systems

The junction box for the fan/blower systems has been factory installed. This system requires that 110-120 VAC to be wired to the factory installed junction box before the fireplace is permanently installed. Refer to Figure 22: Blower Wiring Diagram.

Optional DC Remote Systems

Refer to instructions that come with the remote control to connect the terminals to the wiring. Attached the two (2) terminals from the battery operate remote to the two (2) pigtail from the gas valve.

FINAL INSTALLATION

FINAL INSTALLATION

Wall Finishing:

Definitions:

Combustible Materials - Materials made of or surfaced with wood, compressed paper, plant fibers, or other materials that are capable of being ignited and burned. Such materials are considered combustible even though flameproof, fire retardant, treated, or plastered.

Non-Combustible Materials - Materials which will not ignite and burn. Such materials are those consisting entirely of steel, iron brick, tile, concrete, slate, glass, marble, or combination thereof, or have a UL Fire rating of Zero (0).

High Temperature Sealant Material - Sealant that will withstand high temperature; General Electric RTV103 or equivalent.

Finishing the fireplace flush with a wall:

When finishing the face of the fireplace, combustible material may be brought up to the sides of the fireplace, but must never overlap onto the black metal face. The black metal face may be covered with non-combustible material only. However, the louvers must never be covered with finishing materials. After applying the finishing material, a non-combustible sealant, 1/8" minimum, must be used to close off any gaps at the top and sides between the fireplace and the finishing to prevent cold air leaks. Refer to Figure 7: Finishing Material section in this manual for allowable locations for combustible materials.

Installation Components On Fireplace:

Hood Installation

All fireplaces come with a hood. Remove the hood from the top of the unit. To install, locate the three holes on the underside of the top outer shell, near the top louvers. Remove the top louver and use the three screws supplied to attach hood. See Figure 26: Hood Installation. Re-install the top louver.

<p>WARNING Failure to install hood may cause fire hazard and/or discoloring to the mantel finish.</p> <p>Fireplace operations without a hood is permitted only if the mantel requirements are 6" higher than required height and projections as shown in Figure 4: Mantel Clearance</p>
--

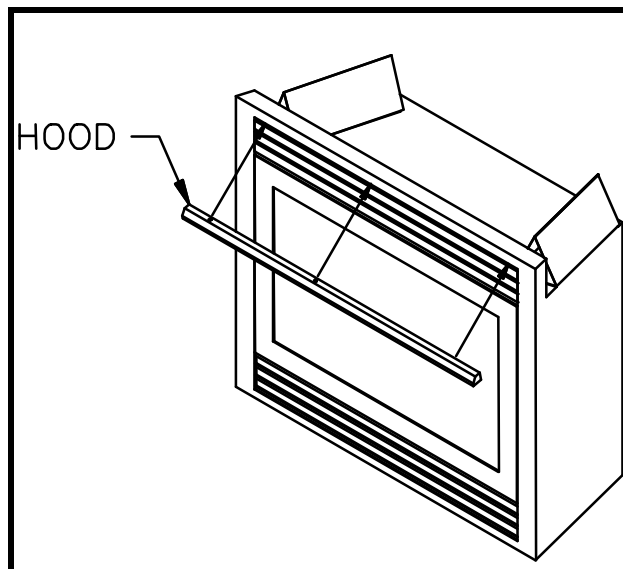

Figure 26: Hood Installation

FINAL INSTALLATION

Glass Removal:

WARNING

Do not operate appliance with the glass front removed, cracked or broken. Replacement of the glass should be done by a licensed or qualified service person.

To remove the glass

1. Remove the top bottom louver.
2. Open the lower access door. Using your right hand, simply unlatch the handle by pushing the green handle down.
3. Use your left hand to pull the bottom flange forward as you push the handle toward the rear of the fireplace.
4. Remove the glass by lifting the bottom out and slightly up to clear top two (2) eyelets on the top flange of the glass frame (below the bottom of the top louver).
5. Put glass aside.

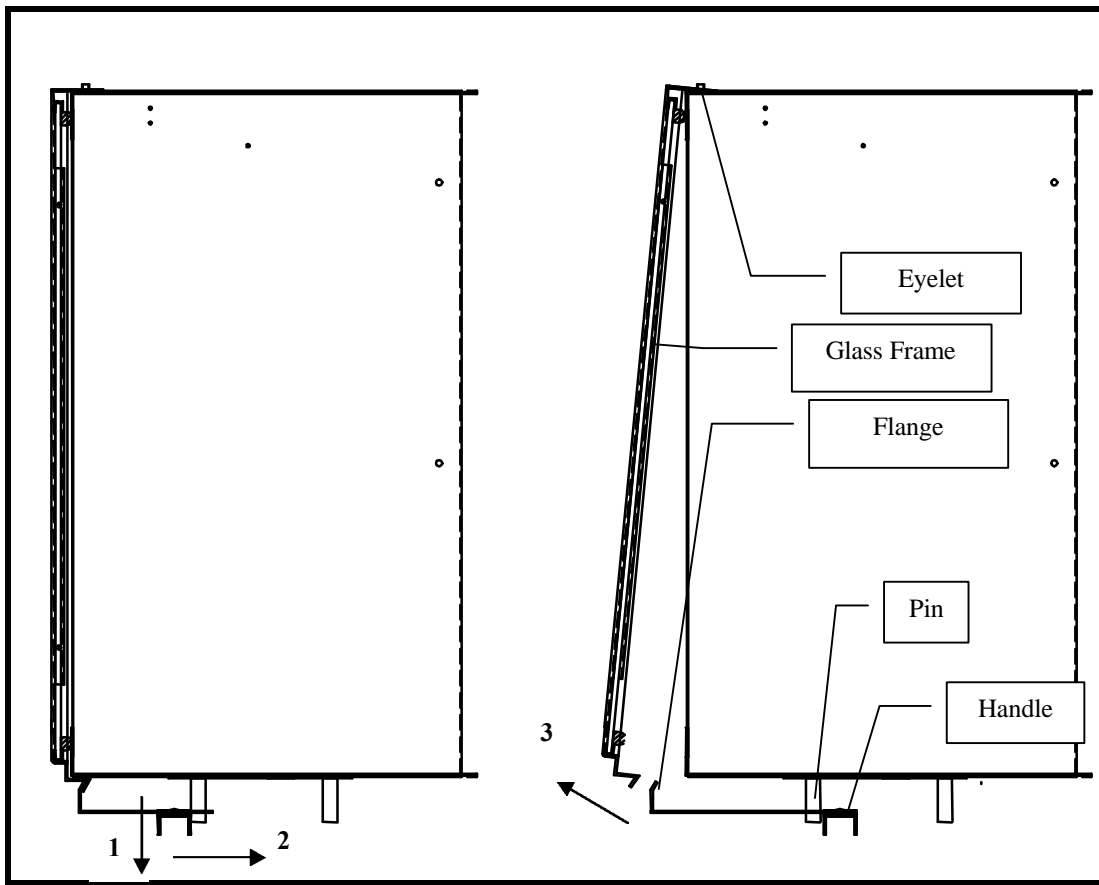

Figure 27: Glass Removal

FINAL INSTALLATION

Rock Wool Placement:

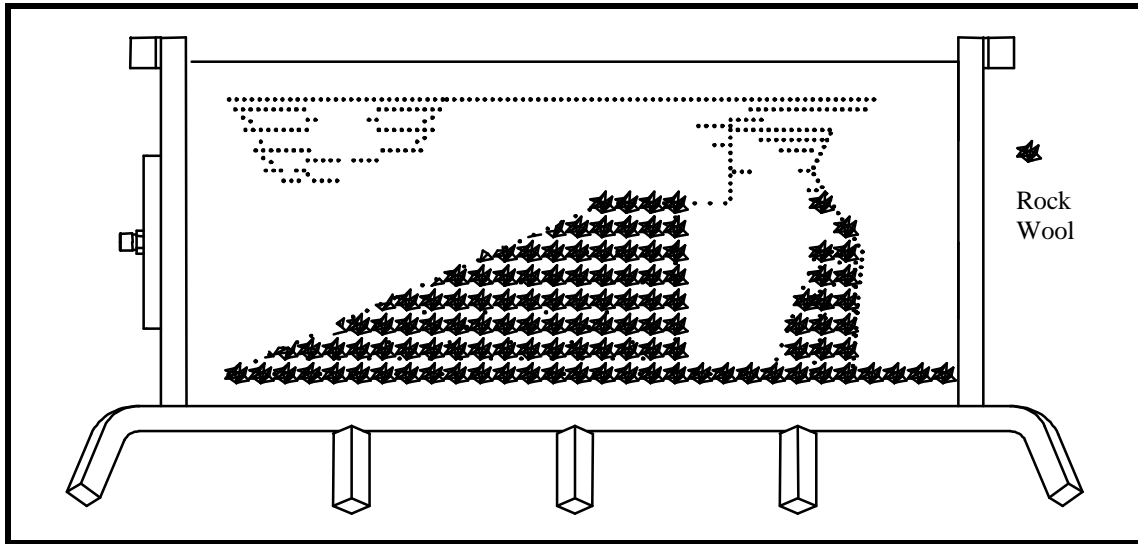

Figure 28: Rock Wool Placement

Rock wool needs to be placed on the burner covering the holes at the front of the burner in order to give the “glowing ember” appearance. Refer to the figure above for the placement of rock wool. The rock wool should be pulled apart into chunks roughly the size of a nickel. Cover the burner areas shown above. The bag supplied has an excess of rock wool. The excess can be used to periodically replace the rock wool.

WARNING

Do not use entire bag of rock wool to cover the burner. This could result in poor performance of flame and glow, which may lead to potential sooting.

Lava Rock Placement:

Sprinkle lava rock on the **floor** of the inner chamber. The rock should not be piled up in any area. It should be placed in a single layer only.

WARNING

Do not sprinkle the lava rock, ember chunk on top of the burner. This may cause potential sooting, glass breakage and fire hazard

FINAL INSTALLATION

Log Placement:

This fireplace is supplied with a set of four (4) ceramic fiber logs. Do not handle these logs with your bare hands! Always wear gloves to prevent skin irritation from ceramic fibers. After handling logs, wash your hands gently with soap and water to remove any traces of fibers. Install logs as shown in the following pictorial.

Step 1: Place the rear log on the two (2) pin locator at the back of the grate. Make sure the rear log rest perpendicular on the grate.

Step 2: Place the right log on the one (1) pin locator at the right hand side of the grate. Make sure the right hand log rest perpendicular on the burner and does not block the burner ports.

Step 3: Place the left log on the one (1) pin locator at the left hand side of the grate and burner pan. Make sure the left log rest perpendicular on the burner and does not block the burner ports.

Step 4: Place the top log resting on the rear log and the left log. The back of the top log should fit on the flat of the rear log and the front of the top log should rest on the left log.

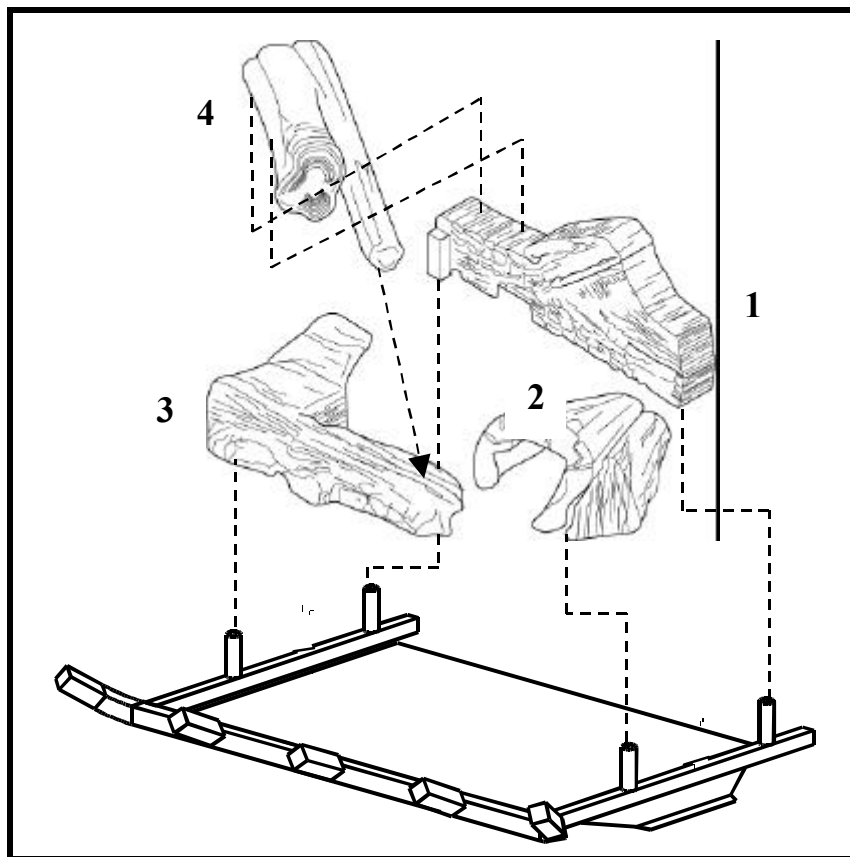

Figure 29: Log Placement

OPERATING INSTRUCTIONS

OPERATING INSTRUCTIONS

Before Lighting the Fireplace:

- Read the **IMPORTANT SAFETY INFORMATION** section at the beginning of this homeowner manual.
- Before lighting, verify the fireplace for possible gas leaks.
- Before lighting, verify for possible obstructions that could be blocking the vent termination or the front louver.
- Any component that is found to be faulty must be replaced with an approved component. Tampering with the fireplace components is dangerous and voids all warranties.
- A small amount of air may be present in the gas line. It will take a few minutes for the lines to purge. Once the purging is complete, the fireplace will light and will operate normally.
- During the initial purging, never allow the gas valve control knob to remain depressed in the pilot position without pushing the ignitor button once every second.
- Subsequent lighting of the fireplace will not require this purging of air from the gas lines, unless the gas valve has been shut-off for a long period.

<p style="text-align: center;">WARNING</p>

<p style="text-align: center;">Remove glass frame assembly during any purging of gas.</p>
--

During Lighting the Fireplace:

You may notice the following:

- A slight odor.
 - ❖ During manufacturing, fabricating, and shipping, various components of this fireplace are treated with certain oils, film, or bonding agents. These chemicals are not harmful but may produce annoying smoke and smells as they are burned off during the initial operation of the fireplace; possibly causing headaches or eye and lung irritation. This is a normal and temporary occurrence.
- Fogging on glass.
 - ❖ For the first few minutes, after each lighting, vapor may condense and fog the glass. This condensation will disappear in a few minutes.
- Noise from the fireplace.
 - ❖ This is due to metal expanding and contracting as it heats up and cools down, similar to the sound produced by a furnace or heating duct.
- Flame appearance.
 - ❖ It will take about 15 to 30 minutes for the flames to turn yellow and some portion of logs to glow.

OPERATING INSTRUCTIONS

LIGHTING INSTRUCTIONS MILLIVOLT IGN

1. STOP! Read the safety information above on this label.
2. Open lower door to reveal RS-OFF-ON rocker switch and gas valve.
3. Turn RS-OFF-ON rocker switch to "OFF". Turn remote switch to "OFF".
4. Push in gas valve knob and turn clockwise to "OFF".
5. Wait five (5) minutes to clear out any gas. Then smell for gas, including near the floor. If you smell gas, STOP! Follow "B" in the safety information above on this label. If you don't smell gas, go to the next step.
6. Find Pilot-located under the log.
7. Turn gas valve counterclockwise to "Pilot".
8. With the control knob pushed in, push in and release the piezo ignitor button to light the pilot.
9. Continuing pushing the control knob in for a further 60 seconds to prevent the flame detector from shutting off the gas while the probe is warming up. Release the control knob.
10. •If the pilot will not stay lit after several tries, turn the gas control knob clockwise to "OFF" and call your service technician or gas supplier.
•If the knob does not pop out when released, stop and call your service technician or gas supplier.
11. Turn knob counterclockwise to "ON".
12. After the pilot has been lit for one minute, the burners can be turned on. Turn RS-OFF-ON switch to "ON" or turn RS-OFF-ON switch to "RS" and remote switch to "ON".

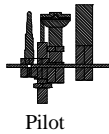

Gas Valve

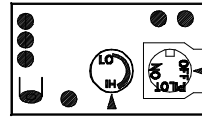

TO TURN OFF GAS TO APPLIANCE

1. Open lower door.
2. Turn RS-OFF-ON rocker switch to "OFF".
3. Push in gas valve knob slightly and turn clockwise to "OFF".
4. Close the lower door.

FOR YOUR SAFETY READ BEFORE LIGHTING

WARNING: If you do not follow these Instructions exactly, a fire or explosion may result causing property damage, personal injury or loss of life.

A. This appliance is equipped with an ignition device (piezo) which automatically lights the pilot. When lighting the pilot, follow these instructions exactly.

B. BEFORE OPERATING smell all around the appliance area for gas. Be sure to smell next to the floor because some gas is heavier than air and will settle on the floor.

WHAT TO DO IF YOU SMELL GAS

- * Do not try to light any appliance
- * Do not touch any electric switch; do not use any phone in your building.
- * Immediately call your gas supplier from a neighbor's phone. Follow the gas supplier's instructions.
- * If you cannot reach your gas supplier, call the fire department.

C. Use only your hand to push in or turn the gas control knob. Never use tools. If the knob will not push in or turn by hand, don't try to repair it, call a qualified service technician. Force or attempted repair may result in a fire or explosion

D. Do not use this appliance if any part has been under water. Immediately call a qualified service technician to inspect the appliance and to replace any part of the control system and any gas control which has been under water.

OPERATING INSTRUCTIONS

LIGHTING INSTRUCTIONS ELECTRONIC IGN

1. STOP! Read the safety information above on this label.
2. Set the thermostat to lowest setting.
3. Turn off all electric power to the appliance.
4. This appliance is equipped with an ignition device which automatically lights the burner. Do not try to light the burner by hand.
5. Wait five (5) minutes to clear out any gas. Then smell for gas, including near the floor. If you smell gas, STOP! Follow "B" in the safety information above on this label. If you don't smell gas, go to the next step.
6. Turn on all electric power to appliance.
7. Set thermostat to desired setting.
8. Turn RS-OFF-ON rocker switch to "ON"
9. If the appliance will not operate, follow the instructions "To turn Off Gas To Appliance" and call you service technician or gas supplier.

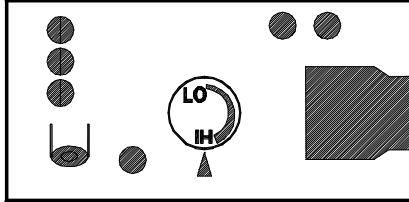

Electronic Gas Valve

TO TURN OFF GAS TO APPLIANCE

1. Open lower door.
2. Turn RS-OFF-ON rocker switch to "OFF".
3. Turn off all electric power to the appliance if service is to be performed
4. Close lower door.

FOR YOUR SAFETY READ BEFORE LIGHTING

WARNING: If you do not follow these Instructions exactly, a fire or explosion may result causing property damage, personal injury or loss of life.

- A. This appliance is equipped with an ignition device (piezo) which automatically lights the pilot. Do not try to light the burner by hand.
- B. BEFORE OPERATING smell all around the appliance area for gas. Be sure to smell next to the floor because some gas is heavier than air and will settle on the floor.
- C. Turn off all electric power to appliance.
- D. Do not use this appliance if any part has been under water. Immediately call a qualified service technician to inspect the appliance and to replace any part of the control system and any gas control which has been under water.

WHAT TO DO IF YOU SMELL GAS

- * Do not try to light any appliance
- * Do not touch any electric switch; do not use any phone in your building.
- * Immediately call your gas supplier from a neighbor's phone. Follow the gas supplier's instructions.
- * *If you cannot reach your gas supplier, call the fire department.

MAINTENANCE

MAINTENANCE

WARNING

Turn off gas before servicing fireplace. It is recommended that a qualified service technician perform these check-ups at the beginning of each heating season.

The appliance area be kept clear and free from combustible materials, gasoline and other flammable vapors and liquids. The flow of combustion and ventilation air not to be obstructed.

Burner, Pilot and Control Compartment:

Keep the control compartment, logs, and burner areas surrounding the logs clean by vacuuming or brushing at least twice a year. Make sure the burner porting, pilot air opening and burner air opening free of obstructions at all time.

Pilot Flame:

The flames from the pilot should be visually checked as soon as the heater is installed and periodically during normal operation. **The pilot flame must always be present when the fireplace is in operation.** Refer to Figure 30: Pilot Flame Appearance. The pilot flame has three distinct flames, one engulfing the thermopile, one engulfing the thermocouple, and the other reaching to the main burner. **On electronic system, pilot does not have the thermopile.**

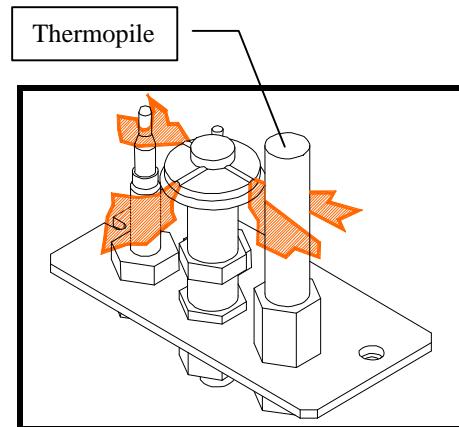

Figure 30: Pilot Flame Appearance

Burner Flame:

The flames from the burner should be visually checked as soon as the heater is installed and periodically during normal operation. In normal operation, at full rate, and after approximately 15-30 minutes, the flame appearance in Figure 31: Burner Flame Appearance should be observed.

NOTE

The type of installation, vent system configuration, and wind effects may cause the flame patterns to vary.



Figure 31: Burner Flame Appearance

MAINTENANCE

Vent System:

The fireplace and venting system should be inspected before initial use and at least annually by a qualified field service person. Inspect the external vent cap on a regular basis to make sure that no debris is interfering with the airflow. Inspect entire venting system to ensure proper function.

Refer to the **VENT INSTALLATION** section for removing and reinstalling vent components.

Glass Door:

Periodically clean the glass door as necessary. You should thoroughly clean the inside of the glass door after using the fireplace for the second or third times.

When cleaning the glass, remember:

- **Do not remove the glass when hot.** Allow glass to cool before removal.
- NEVER use abrasive materials.
- Keep children and pets a safe distance away.
- Never operate the fireplace without the glass door properly secured.
- Never operate the fireplace if the glass is broken.
- Replace any glass that is chipped, cracked, or broken. Replacement glass door assemblies **MUST** be supplied by the fireplace manufacturer -**No substitute materials may be used.** Refer to **Glass Removal** section.
- Handle glass door with care to avoid striking or scratching it on hard objects.

To clean glass door, follow “Glass Removal” procedure outlined in the **FINAL INSTALLATION** section. Film deposit on the inside of the glass should be cleaned off using a nontoxic, non-corrosive, non-abrasive, mild-cleaning solution. Simply apply an adequate amount to the glass and wipe off with a damp cloth. After all maintenance has been completed, re-install glass door.

Logs

Leave logs installed in the fireplace for cleaning. Vacuum surface of the logs with a brush attachment. If logs must be removed for cleaning, handle carefully by holding gently at each end. Gloves are recommended to prevent skin irritation from ceramic fibers. If skin becomes irritated, wash gently with soap and water. Vacuum surface of logs with brush attachment or brush logs with a soft bristle brush (i.e. clean, dry paintbrush). To place logs back in the fireplace, refer to “Log Placement” found in the **FINAL INSTALLATION** section.

NOTE

Do not use cleaning fluid to clean logs.

Rock Wool

Make sure the rock wool is placed according to the section Rock Wool Placement on page 26. You may be required to add rock wool if the quantity is low.

PARTS LIST/ILLUSTRATION

PARTS LIST / ILLUSTRATION

Logs:

Item	Description	320DV4136	320DV4742
1	Rear Log	37D0587	37D0591
2	Right Log	37D0589	37D0589
3	Left Log	37D0588	37D0592
4	Top Log	37D0590	37D0667

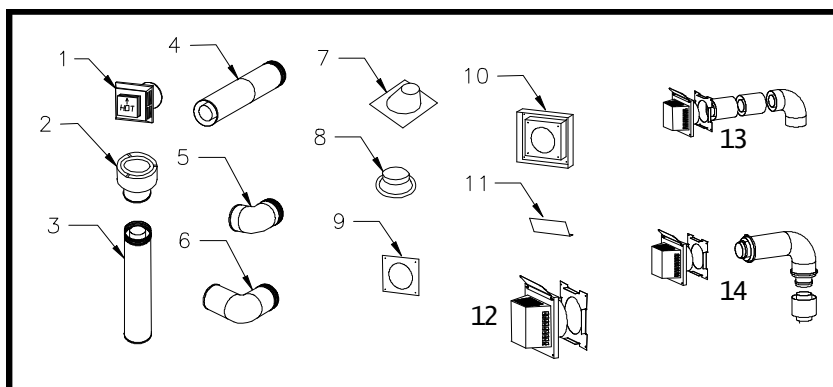
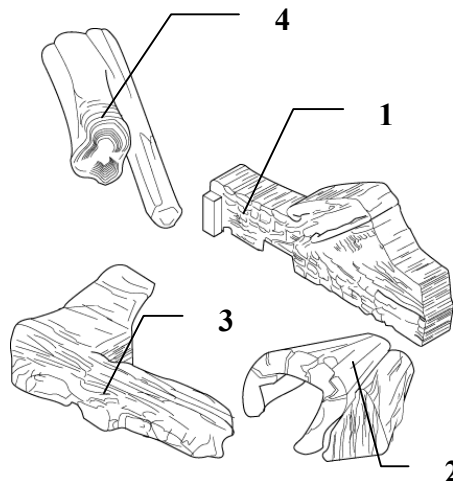

Vent Components:

Item	Simpson DuraVent or Monessen P/N	Description	Qty/Box
1	985	Horizontal Square High Wind Termination Cap	1
2	980	Vertical Termination	1
3	908	6" Pipe Length	6
3	907	9" Pipe Length	6
3	906	12" Pipe Length	6
3	904	24" Pipe Length	6
3	903	36" Pipe Length	6
3	902	48" Pipe Length	6
4	911	11" To 14 5/8" Pipe, Adjustable	6
4	917	17" To 24" Pipe, Adjustable	6
5	945	45° Elbow	6
5	945G	45° Swivel Elbow	6
6	990	90° Elbow	6
6	990G	90° Swivel Elbow	6
7	943	Flashing, 0/12 To 6/12 Roof Pitch	6
8	953	Storm Collar	6
9	963	Firestop	6
10	950	Vinyl Siding Standoff	1
11	37D0115 (Monessen)	Deflector Shield	1
12	HTC (Monessen)	Horizontal Termination Cap	1
13	HRFK (Monessen)	Horizontal Rigid Termination Kit	1
14	HFTK20 (Monessen)	Horizontal Flex Termination Kit	1

PARTS LIST/ILLUSTRATION

Firebox Components:

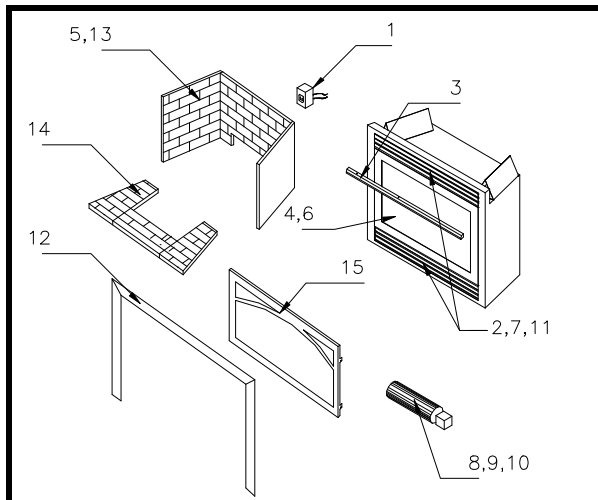

Item	Description	Qty	320DV4136	320DV4742
Standard Features				
1	Junction Box Assembly	1	26D2128K	26D2128K
2	Black Louver	6	26D0697K	26D0699K
3	Hood/Canopy	1	37D0288K	37D0537K
4	Temper Glass Frame Assembly	1	37D0279K	37D0615K

Factory Installed Options

5	Standard Firebrick Center	1	37D0567K	37D0573K
5	Standard Firebrick Right	1	37D0568K	37D0568K
5	Standard Firebrick Left	1	37D0569K	37D0569K
6	Ceramic Glass Frame Assembly	1	37D0282K	37D0616K
7	Brass Louver	6	26D0703K	26D0705K
8	Blower Motor	1	26D0748K	26D0748K
9	Thermostat Sensor	1	26D2870K	26D2870K

Accessories/Field Installed Options

10	Blower System			
	Blower with Speed Ctrl	1	BLO	BLO
	Thermostatic Sensor	1	BTS	BTS
11	Louver System			
	Brass Louver	1	L36BR	L42BR
	Chrome Louver	1	L42CH	L42CH
	Filigree	1	BRFK36	BRFK42
12	Trim System			
	Curved Design - Brass	1	BRTK36C	BRTK42C
	Curved Design - Chrome	1	CHTK36C	CHTK42C
	4" Wide Brass Wall Trim	1	BRTW36	BRTW42
13	Firebrick Walls			
	Standard	1	FB4136T8	FB4742T8
	Weathered	1	FB4136W8	FB4742W8
14	Firebrick Floors			
	Standard	1	FB4136TF8	FB4742TF8
	Weathered	1	FB4136WF8	FB4742WF8
15	Arch Frame - Brass	1	BRAF4136	BRAF4742

PARTS LIST/ILLUSTRATION

Engine Components:

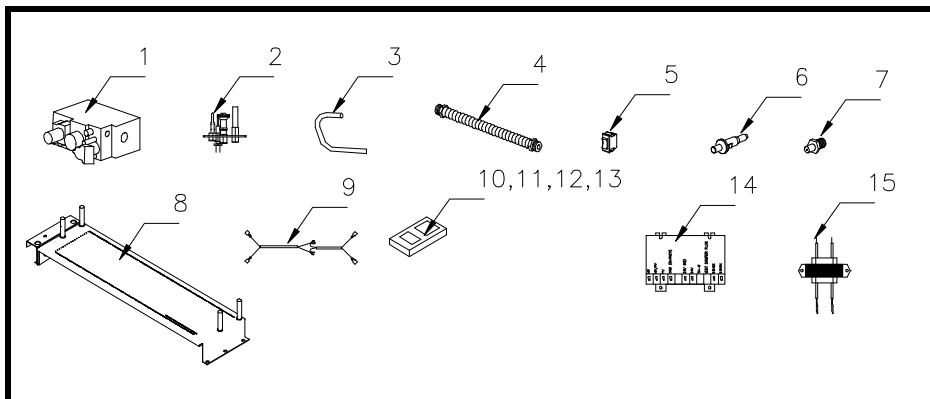

Standing Pilot – Millivolt Control

Item	Description	Qty	4136NV	4136NV	4742NV	4742PV
1	Gas Valve Assembly	1	37D0117K	37D0118K	37D0117K	37D0118K
2	Pilot Assembly	1	37D0018K	37D0019K	37D0018K	37D0019K
3	Burner Tube	1	37D0586K	37D0586K	37D0586K	37D0586K
4	Flexhose with Shutoff Valve	1	23D6046K	23D6046K	23D6046K	23D6046K
5	Rocker Switch	1	26D0491K	26D0491K	26D0491K	26D0491K
6	Piezo Igniter	1	14D0503K	14D0503K	14D0503K	14D0503K
7	Injector	1	37D0370K	37D0353K	37D0071K	37D0692K
8	Burner Assembly	1	37D0629K	37D0629K	37D0630K	37D0630K
9	Wire Assembly	1	36D0009K	36D0009K	36D0009K	36D0009K

Accessories

10	Thermostatic Remote Control	1	TRC	TRC	TRC	TRC
11	Remote Control On/Off	1	MRC	MRC	MRC	MRC
12	Wall Switch Kit	1	MVWS	MVWS	MVWS	MVWS
13	Wall Thermostat Kit	1	MVWTS	MVWTS	MVWTS	MVWTS

Conversion Kit (Not Shown)

	4136 Conversion NG to LPG	1	SNPK323			
	4136 Conversion LPG to NG	1		SPNK323		
	4742 Conversion NG to LPG	1			SNPK363	
	4742 Conversion LPG to NG	1				SPNK363

Electronic Ignition Control

Item	Description	Qty	4136NE	4136NE	4742NE	4742PE
1	Gas Valve Assembly	1	37D0016K	37D0017K	37D0016K	37D0017K
2	Pilot Assembly	1	37D0020K	37D0021K	37D0020K	37D0021K
3	Burner Tube	1	37D0586K	37D0586K	37D0586K	37D0586K
4	Flexhose with Shutoff Valve	1	23D6046K	23D6046K	23D6046K	23D6046K
7	Injector	1	37D0370K	37D0353K	37D0071K	37D0692K
8	Burner Assembly	1	37D0629K	37D0629K	37D0630K	37D0630K
9	Wire Assembly	1	37D0028K	37D0028K	37D0028K	37D0028K
14	Ignition Module	1	37D0026K	37D0026K	37D0026K	37D0026K
15	Transformer	1	37D0027K	37D0027K	37D0027K	37D0027K

Accessories

10	Thermostatic Remote Control	1	TRCE	TRCE	TRCE	TRCE
12	Wall Switch Kit	1	MVWS	MVWS	MVWS	MVWS

TROUBLESHOOTING

TROUBLESHOOTING

Standing Pilot Ignition:

SYMPTOM	POSSIBLE CAUSE	ACTION
1. Spark ignitor will not light pilot after repeated triggering of piezo.	A. Wire disconnected.	Open door and check to make sure wire is connected to ignitor.
	B. Defective ignitor.	Check for spark at electrode and pilot. If no spark and electrode wire is properly connected, replace pilot assembly.
	C. No gas or low gas pressure.	Check remote/manual shut off valve from fireplace. Low pressure can be caused by bent lines, restricted lines, low pressure line pressure. Consult with plumber or gas supplier.
	D. No Propane/LPG in tank	Check Propane/LPG tank. Refill tank
2. Pilot will not stay lit after carefully following lighting instructions.	A. Defective thermocouple	<p>Check that thermocouple flame impinges on thermocouple.</p> <p>Clean and/or adjust pilot for maximum flame impingement.</p> <p>Ensure that the thermocouple connection at the gas valve is fully inserted and tight.</p> <p>Disconnect the thermocouple from the valve, place one millivolt lead wire on the tip of the thermocouple and the other meter lead wire on the thermocouple copper lead. Start the pilot and hold the valve knob in. If the millivolt reading is less than 15 mV, replace pilot assembly.</p>
	B. Defective valve	If thermocouple is producing more than 15 mV, replace faulty valve.
3. Pilot burning, valve knob turned to "ON", switch is turned to "ON" or "RS", but burner will not ignite.	A. Defective switch, wall switch, remote control or wire	<p>Check switch and wire for proper connection. Place jumper wires across terminals of switch. If burner comes on, replace defective switch. If the switch is OK, repeat the same procedure on remote control. If burner comes on, replace remote control.</p> <p>Place jumper wire across wire at gas valves (terminals marked TH and TP/TH). If burner comes on, wires are faulty or connections are bad. Replace wire.</p>
	B. Pilot flame too small	If pilot flame is not close enough to the thermopile, adjust pilot flame.
	C. Defective or malfunctioning thermopile	<p>Check thermopile wire connections to make sure all are tight and that the thermopile is fully inserted into pilot assembly.</p> <p>Check thermopile with a millivolt meter. Connect leads to TP and TP/TH terminals on the control valve. If meter reading is below 325 mV, replace pilot assembly</p>
	D. Defective valve	Turn valve knob to "On" and switch to "ON". Take a reading at the thermopile leads (TP & TP/TH) on the valve. If the meter reads greater than 100 mV and the burner does not light, replace defective valve
4. Frequent pilot outage problem.	A. Pilot flame may be too high or too low, causing pilot safety to drop out	Clean and adjust the pilot flame for maximum flame impingement on thermocouple.

TROUBLESHOOTING

5. The pilot and main burner extinguish while in operation	A. Inner vent pipe leaking exhaust gases back into system	Check for flue product leak. Replace defective pipe section.
	B. Horizontal vent improperly pitched	Check horizontal-venting piping is running upward 1/4" per foot.
	C. Improper vent cap installation	Check for proper and freedom from debris or blockage.
6. Glass Soots	A. Flame impingement on logs	<p>Install log set per the instructions</p> <p>Inspect the injector and air intake area. Make sure this area does not have any blockage from debris and clean.</p> <p>Check gas supply</p>
7. Flame burn blue and lifts off burner (ghosting)	A. Insufficient oxygen being supplied	<p>Ensure that the vent cap is installed properly and free of debris. Ensure that the vent system joints are tight and have no leaks.</p> <p>Ensure that no debris has been blocking the inner air intake at the bottom back of the combustion chamber.</p> <p>Ensure that the glass is properly secure and latch.</p>

TROUBLESHOOTING

Electronic Pilot Ignition:

SYMPTOM	POSSIBLE CAUSE	ACTION
1. The main burner does not light.	A. Unit junction box not electrically grounded or properly connected	Ensure that 110 VAC is connected.
	B. No gas or low gas pressure.	Check remote/manual shut off valve from fireplace. Low pressure can be caused by bent lines, restricted lines, low pressure line pressure. Consult with plumber or gas supplier.
	C. No Propane/LPG in tank	Check Propane/LPG tank. Refill tank
	D. Air in gas line	Purge gas line of air
2. Frequent pilot outage problem.	A. Pilot flame may be too high or too low, causing pilot safety to drop out	Clean and adjust the pilot flame for maximum flame impingement on thermocouple.
3. The pilot and main burner extinguish while in operation	A. Inner vent pipe leaking exhaust gases back into system	Check for flue product leak. Replace defective pipe section.
	B. Horizontal vent improperly pitched	Check horizontal-venting piping is running upward 1/4" per foot.
	C. Improper vent cap installation	Check for proper and freedom from debris or blockage.
4. Glass Soots	A. Flame impingement on logs	Install log set per the instructions Inspect the injector and air intake area. Make sure this area does not have any blockage from debris and clean.
5. Flame burn blue and lifts off burner (ghosting)	A. Insufficient oxygen being supplied	Ensure that the vent cap is installed properly and free of debris. Ensure that the vent system joints are tight and have no leaks. Ensure that no debris has been blocking the inner air intake at the bottom back of the combustion chamber. Ensure that the glass is properly secure and latch.

LIMITED LIFETIME WARRANTY POLICY

Lifetime Warranty

The following components are warranted for life to the original owner, subject to proof of purchase: Firebox, Combustion Chamber, Heat Exchanger, Grate and Stainless Steel Burners.

Five Year Warranty

The following components are warranted five (5) years to the original owner, subject of proof of purchase: Ceramic Fiber Logs, Catalytic Filter and Aluminized Burners

Basic Warranty

Monessen Hearth Systems (MHS) warrants the components and materials in your gas appliance to be free from manufacturing and material defects for a period of two years from date of installation. After installation, if any of the components manufactured by MHS in the appliance are found to be defective in materials or workmanship, MHS will, at its option, replace or repair the defective components at no charge to the original owner. MHS will also pay for reasonable labor costs incurred in replacing or repairing such components for a period of two years from date of installation. Any products presented for warranty repair must be accompanied by a dated proof of purchase.

This Limited Lifetime Warranty will be void if the appliance is not installed by a qualified installer in accordance with the installation instructions. The Limited Lifetime Warranty will also be void if the appliance is not operated and maintained according to the operating instructions supplied with the appliance, and does not extend to (1) firebox/burner assembly damage by accident, neglect, misuse, abuse, alterations, negligence of others, including the installation thereof by unqualified installers, (2) the costs of removal, reinstallation or transportation of defective parts on the appliance, or (3) incidental or consequential damage. All service work must be performed by an authorized service representative.

This warranty is expressly in lieu of other warranties, express or implied, including the warranty of merchantability of fitness for purpose and of all other obligations or liabilities. MHS does not assume for it any other obligations or liabilities in connection with sale or use of the appliance. It states that do not allow limitations on how long an implied warranty lasts, or do not allow exclusion of indirect damage, those limitations of exclusions may not apply to you. You may also have additional rights not covered in the Limited Lifetime Warranty.

MHS reserves the right to investigate any and all the claims against the Limited Lifetime Warranty and decide upon method of settlement.

For information about this warranty, contact:

**Technical Services
Monessen Hearth Systems
149 Cleveland Drive
Paris, Kentucky 40361**