

MONESSEN HEARTH SYSTEMS

36" and 42"

WOOD BURNING FIREPLACES

INSTALLATION AND OPERATING INSTRUCTIONS

Glass Doors, Fan Assembly, and Outside Combustion Air Kit Available



MODELS:

BWB400A BWB400IA BWBC400A BWBC400IA
BWB500A BWB500IA BWBC500A BWBC500IA

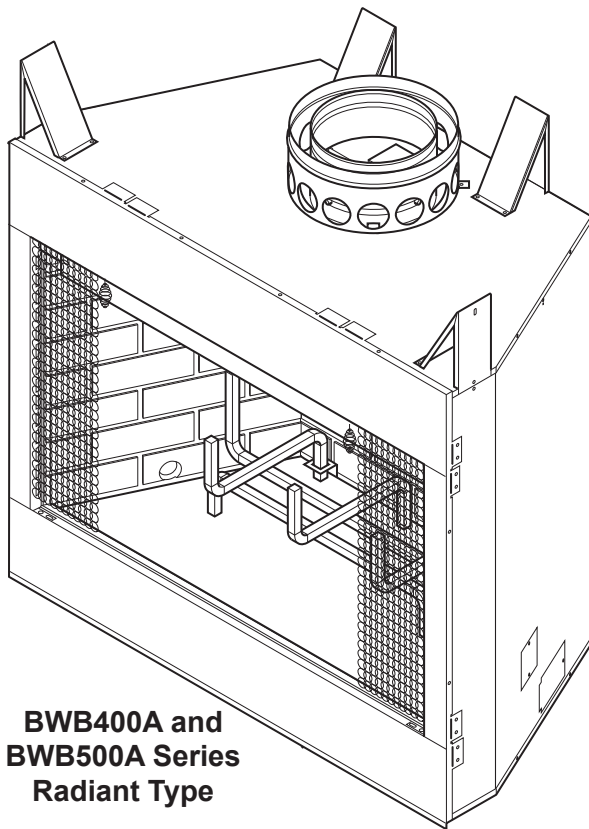

**BWB400A and
BWB500A Series
Radiant Type**

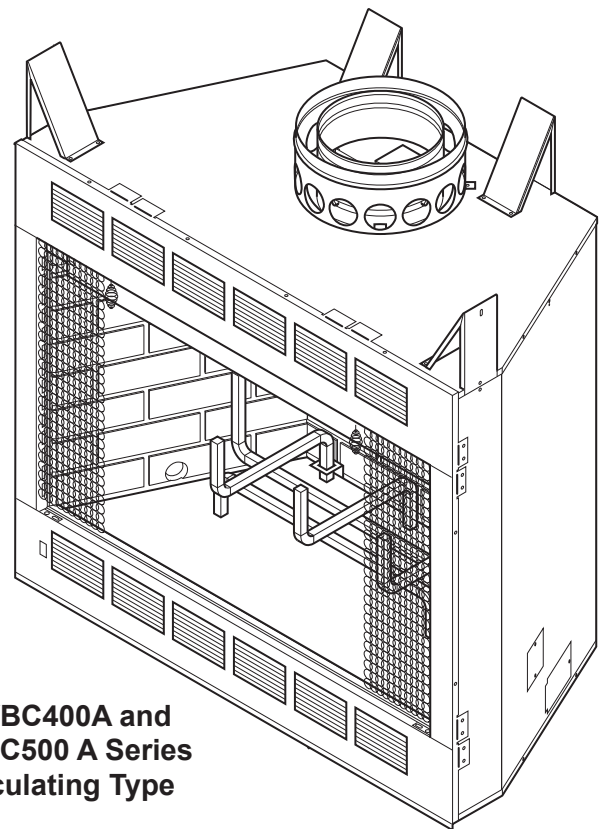

**BWBC400A and
BWBC500 A Series
Circulating Type**

These fireplaces are U. L.[®] listed for use with "S" Series chimney system components.

Only Unvented Gas Log Sets which have been found to comply with the Standard For Unvented Room Heaters ANSI Z21.11.2, are to be installed in this fireplace. A hood must be installed when mantle is installed at 12" from fireplace opening.

READ BEFORE INSTALLING. SAVE THESE INSTRUCTIONS

CONTENTS

CONGRATULATIONS!

You have chosen the finest wood burning fireplace available. Your fireplace has been designed for years of heating and viewing enjoyment. Please take time to read this entire manual before installing or operating your fireplace.

| | | | |
|---|-----------|---|-------------------|
| Listing and Code Approval | 2 | Outside Combustion Air Precautions and Recommendations | 25 |
| Important Safety Information | 3 | Combustion Air..... | 25 |
| Operation Guidelines | 4 | Model AK-4 Combustion Air Assembly..... | 27 |
| How Your Fireplace Should Be Used..... | 4 | Installing Model 403 Duck Connector | 28 |
| How Your Fireplace Works..... | 4 | Gas Appliance Installation | 28 |
| Residential Installation | 4 | Trim and Mantel Installation | 31 |
| Glass Doors | 4 | Gas Appliances | 31 |
| Flue Damper | 4 | Wood Burning Fireplaces..... | 32 |
| Grate | 5 | Glass Door Installation | 33 |
| Chimneys | 5 | Fan Accessory | 33 |
| Product Features | 6 | Fireplace Operation | 34 |
| Fireplace Location | 7 | Advantages of a Wood Burning Fireplace | 34 |
| Fireplace Dimensions | 8 | Which Woods Are Best | 34 |
| Installation Preparation | 9 | How to Build a Better Fire | 34 |
| Floor Protection | 11 | Wood vs. Fossil Fuels..... | 35 |
| Fireplace Installation | 13 | A Few Words of Caution | 35 |
| Unpacking Fireplace | 13 | Maintenance | 36 |
| Clearances..... | 13 | Fuel Storage | 36 |
| Chimney Installation | 15 | Disposal of Ashes | 36 |
| Installing Chimney Safety Information | 14 | Chimney Maintenance | 36 |
| Locating Center Line..... | 17 | Fireplace Maintenance..... | 36 |
| Installing Firestop Spacer | 17 | Glass Door Maintenance | 36 |
| Installing “S” Series Chimney Spacers | 18 | Checklist of DOs and DON'Ts..... | 37 |
| Installing Chimney Supports | 19 | Replacement parts | 39 |
| Elbow Installation | 19 | Warranty | Back Cover |
| Offset Installation Sequence | 21 | | |
| Chimney Cap Installation | 22 | | |
| Chimney Chase Installation | 24 | | |

LISTING AND CODE APPROVALS

The instructions contained in this manual provide the information necessary to install this fireplace in accordance with Underwriter’s Laboratories requirements and in compliance with the National Fire Protection Association Standard No. 211. Some codes may require the fireplace and chimney be electrically grounded. Before beginning the installation, check with local building officials to obtain required permits and assure compliance with local regulations and codes. If you encounter problems with code requirements, contact your dealer for assistance.

IMPORTANT: This fireplace is listed by Underwriters Laboratories to U.L. 127 standard for factory-built fireplaces. The design of this fireplace and these instructions complied with applicable safety standard for a factory built fireplace in effect at the time the fireplace was manufactured. You should be aware, however, that failure to install, operate, and maintain this or any other factory built fireplace properly can result in a house fire or other occurrences that could cause deaths, injuries, and property damages. Persons installing and/or supervising the installation of this fireplace must have appropriate skills in using the tools and techniques required and have reading and comprehension skills sufficient to read and follow these instructions. These instructions contain warnings, cautions, and notes to emphasize important safety information. To assure that safe and satisfactory service is received from this fireplace, please read the following special notices and all the contents of this manual.

IMPORTANT SAFETY INFORMATION

INSTALLER

Please leave these instructions with the owner.

OWNER

Please retain these instructions for future reference.

WARNING

- Read these instructions entirely before beginning any part of the installation. Save these instructions for any future repairs.
- Use these instructions as a guide during the installation of the fireplace.
- Install all the parts used with this fireplace system in accordance with these installation instructions. Failure to do so may be hazardous and will void the warranty.
- Do not alter fireplace and accessories in any way that is not specifically recommended in this manual.
- Refer to your local building code for local requirements pertaining to installation of factory-built fireplaces. Monessen Hearth Systems fireplaces are intended for installation and use according to standard NFPA 211 of the National Fire Protection Association.
- Do not install fireplace with a masonry flue.
- Do not pack required air spaces with combustible material or insulation not specifically recommended for use in such areas.

NOTICE

This fireplace is *NOT* designed for installation in manufactured homes without a vented attic space. Fireplace may be installed in manufactured homes which have a vented attic space if the fireplace is equipped with GD36BA, GD36PBA, GD36SSA, GD42BA, GD42PBA or GD42SSA glass doors, an AK6 outside combustion air kit (instead of the AK4 outside combustion air kit offered for residential type homes as described later by this instruction manual), a SVTR firestop thimble, and the minimum installed height from floor to flue outlet is 13'. (See *Figure 14, page 16.*)

CAUTION

Do not use a fireplace insert or other product not specified for use with this fireplace.

WARNING

Improper installation or use of this fireplace will void its warranty and can cause:

- Damage to the fireplace from overheating.
- Hazardous temperatures to develop on combustible materials adjacent to the fireplace or chimney.
- The emission of smoke, sparks or hazardous gases into the dwelling.
- Leakage of rain water into the dwelling.

OPERATION GUIDELINES

HOW YOUR FIREPLACE SHOULD BE USED

This fireplace is intended for supplemental heating only and is not intended for use as a primary heating system.

This fireplace is designed to sit directly on a combustible floor. The fireplace must be installed with clearances to combustible building materials as specified by this manual. Only parts manufactured by Monessen Hearth Systems and labeled for use with this fireplace should be used in the installation of the fireplace except for special roof flashings that may be fabricated locally. The use of improper parts in the installation can be hazardous and voids the warranty offered by Monessen Hearth Systems.

This fireplace is designed to burn solid wood fuel (wood), UL-classified processed solid fuel fire logs, or a certified decorative gas appliance may be installed in the fireplace as described later by this instruction manual.

This fireplace is not designed to burn coal, unplumbed liquid fuels, unplumbed gaseous fuels or household refuse. Any attempt to burn these fuels in the fireplace can be hazardous.

HOW YOUR FIREPLACE WORKS

As wood is burned in the fireplace, room air entering the fireplace is circulated around the fireplace firebox. This air circulation protects the firebox from overheating. Air circulation through the fireplace must not be blocked or restricted in any manner. Blocking or restricting air circulation through the fireplace can cause a fire hazard.

RESIDENTIAL INSTALLATION

In residential type installation, an AK4 outside combustion air kit may be connected to the left side of the fireplace to allow outside air to enter the firebox through a dampered opening in that side of the fireplace. This *outside combustion air* feature reduces the room air used for combustion and prevents excessive heat loss from the room. When the fireplace is in use, the fireplace's "outside combustion air" damper connected to an AK4 may be opened to allow air from outside to enter the fireplace firebox. When the fireplace is not in use, the "outside combustion air" damper should be closed to prevent cold air from entering the firebox. An "outside combustion air" damper is open when its control lever is up and closed when its control lever is down. A control lever for the *outside combustion air* damper is located inside the firebox near the top of the side firebrick on the left side of the fireplace. The design of the fireplace allows the routing of the combustion air duct downward or horizontally to obtain the outside combustion

air; this permits flexibility in planning your installation. See Figures 24 thru 27 and their instructions for typical installation of outside combustion air kits. Review the precautions and recommendations in this manual pertaining to outside combustion air.

Note: *Outside air for combustion is optional in residential type installations unless required by local codes. Outside air for combustion it is mandatory in manufactured home installations. Use an AK6 outside combustion air kit in manufactured home installations, instead of the AK4 offered for residential type installations.*

GLASS DOORS

Glass doors (models GD36BA, GD36PBA, GD36SSA, GD42BA, GD42PBA and GD42SSA by Monessen Hearth Systems) may be installed to receive the maximum benefit from your fireplace. For large fires, the maximum heating benefit from the fireplace will be obtained with the doors open due to the high amount of radiant heat being emitted out of the front opening of the fireplace. With a small fire, or before retiring in the evenings, it is best to operate the fireplace with the doors closed to prevent excessive room air from being drawn up the chimney. When the doors are open, the mesh screens should be closed to help keep burning embers from popping out of the firebox.

Note: *Glass doors are mandatory on fireplaces installed in manufactured homes.*

WARNING

Fireplaces equipped with glass doors should be operated only with the glass doors fully open or fully closed. If doors are left partly open, gas and flame may be drawn out of the fireplace opening, creating risks of both fire and smoke.

FLUE DAMPER

The fireplace also is equipped with a flue damper which must be open when the fireplace is in use. The flue damper control lever is located inside the fireplace. The counterweighted damper is operated by simply unlocking up to open or pulling and locking down to close the damper. When the fireplace is not in use, the damper should be closed to prevent cold air from entering the chimney as well as preventing warm air in the room from escaping up the chimney.

Note: It is normal for a small amount of smoke to be released from the upper portion of the fireplace the first few times you use your new Monessen Hearth Systems fireplace. This results from an oil residue on the metal. Open a door or window to allow the smoke to escape.

GRATE

The grate included with this fireplace helps to appropriately locate and contain the burning wood.

WARNING Failure to use this grate may cause overheating of parts of the fireplace and allow large pieces of burning wood to roll forward out of the firebox. Replace warped or damaged grate only with a Monessen Hearth Systems grate.

CHIMNEYS

All fireplace chimneys are in direct contact with cold air on the exterior of the structure. Consequently, when the fireplace is not in use, cold air can fall down the chimney of the fireplace to cool off the fireplace chase. Therefore, the fireplace chase must be insulated to minimize the risk of cold coming into the home. Even if the fireplace chase is adequately insulated, this cannot completely ensure that cold air coming into the structure will be eliminated. Cold air coming inside is a possibility with any fireplace or device that freely uses air on the outside of the structure. Today's homes are more energy-efficient and, therefore, better insulated and tightly constructed. Unfortunately, when air is removed from the house (by a bathroom fan or consumed by a furnace) additional air is needed to replace the air consumed. Unless the additional air is supplied, this can cause a negative pressure in the home. When this happens, the house will draw in outside air from the cracks in the windows, down the fireplace flue or other locations of air leakage in the home. Because cold air coming in may be unavoidable in some structures, Monessen Hearth Systems is not responsible for heat loss or air infiltration through or around the fireplace.

PRODUCT FEATURES

PRODUCT SPECIFICATIONS

- This fireplace is designed to burn solid wood fuel (wood), UL-classified processed solid fuel fire logs, or a certified decorative gas appliance may be installed in the fireplace as described later by this instruction manual.
- The appliance must be properly connected to a venting system.

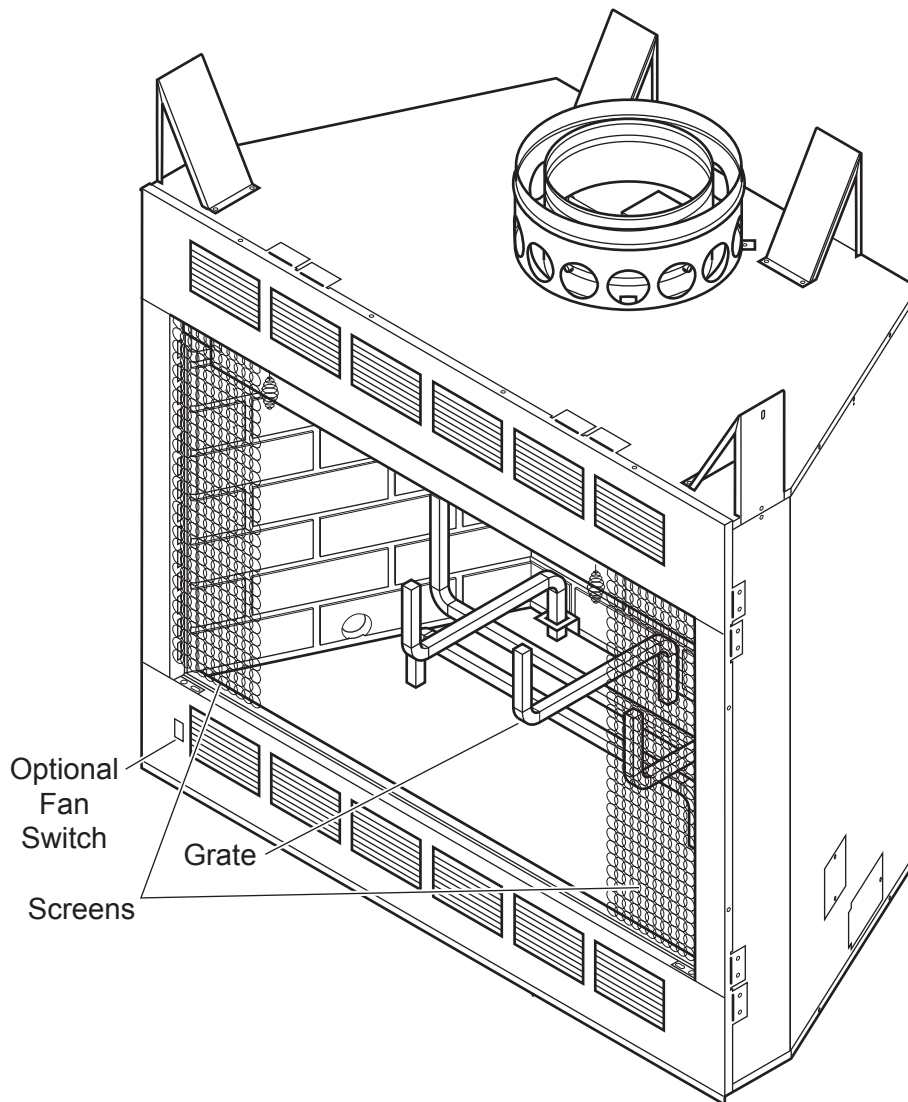

**Figure 1 - Wood Burning Fireplace
(Circulating Unit Shown)**

Plan for the installation of your fireplace. This includes determining where the unit is to be installed, the vent configuration to be used, framing and finishing details, and whether any optional accessories (i.e. blower, wall switch, or remote control) are desired. Consult your local building code agency to ensure compliance with local codes, including permits and inspections.

CAUTION

Do not install fireplace over carpeting.

The following factors should be taken into consideration:

- This fireplace should have sufficient access for its safe operation and maintenance.
- Locate a position where the flue system of the fireplace can be properly installed without damaging the integrity of the building. e.g. cutting wall or ceiling joist (example: load-bearing framing members).
- Install floor protection when the appliance is installed directly on tile or other combustible material.
- Check fireplace and flue system clearance requirements.
- Locate the fireplace in a large and open room that is centrally located in the house. This will optimize heat circulation and comfort.
- Locate fireplace away from frequently opened doors, central heat outlets or returns, or other places where air movements may disturb the airflow around the fireplace.

Note: Air turbulence near the fireplace may cause smoke to spill out of the fireplace opening.

- Locate fireplace near a load bearing wall. Make sure the support structure is strong enough or reinforced if fireplace is to be trimmed with a heavy stone or brick facing and hearth extension.
- This fireplace may be installed along a wall, across a corner, or use an exterior chase. *See Figure 2* for suggested locations.
- Location should be out of high traffic areas and away from furniture and draperies.
- Never obstruct the front opening of the fireplace.
- Do **not** install in the vicinity where gasoline or other flammable liquids are stored.
- Vent pipe routing. See *Venting* section found in this manual for allowable venting configurations.
- Minimum clearances to combustibles, side-wall, ceiling, woodwork, and windows must be maintained. *See Clearances Section in this manual.*

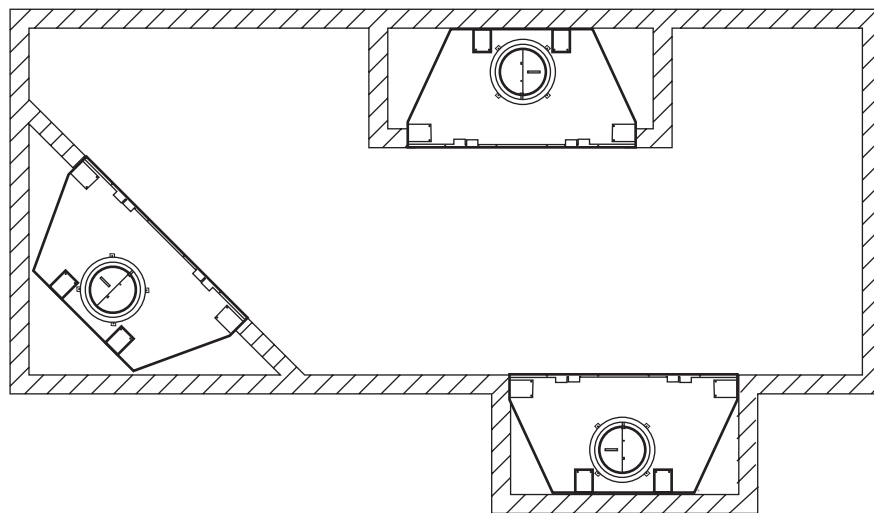

Figure 2 - Suggested Fireplace Locations

FIREPLACE DIMENSIONS

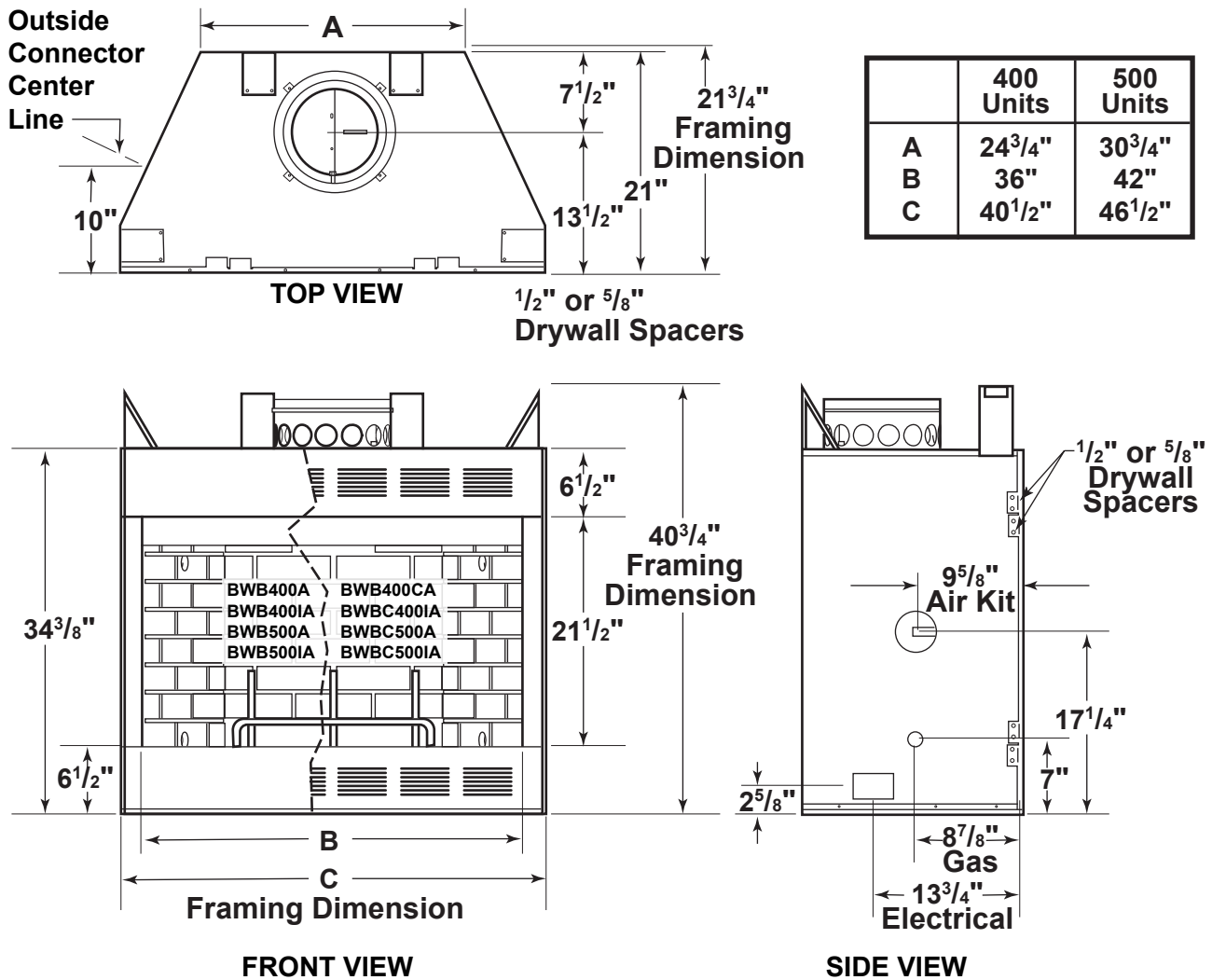

Figure 3 - Fireplace Dimensions

LOCATING CHIMNEY

- Survey the planned location for the fireplace for overhead plumbing or electrical wires, etc. This could make installation harder. It could also be a hazard for persons installing or cleaning the chimney.
- Do not install where the chimney cap will be near abrupt changes in the roof shape, nearby wall or embankments, under or near trees or above the roof of a single story wing of a two story building. *See Figure 4.* Any of these conditions may cause turbulence or pressure condition which may create poor chimney draft and smoke spillage from the fireplace opening into the home.
- Use elbows to offset the chimney to avoid obstructions or to locate the chimney cap in a better location. *See Chimney Offsets Section on pages 18 and 21* for instructions on proper elbow use. Poor installation or location of the chimney cap and/or components can cause wind blown rain to enter the chimney.
- The selected location must have a 15" square combustible material-free space for the chimney to pass through.
- If the chimney is to pass through living or storage spaces, there must be adequate space to enclose the chimney to avoid personal contact with, or damage to, the chimney.

Continued

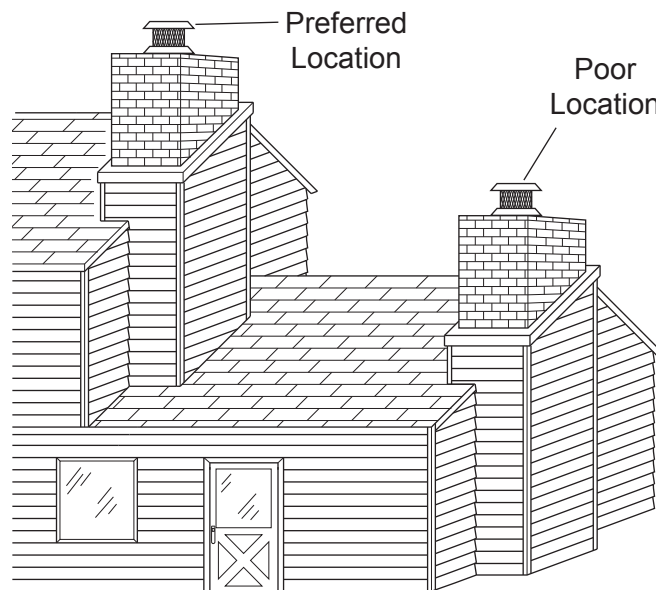

Figure 4 - Preferred Chimney Location

INSTALLATION PREPARATION

LOCATING CHIMNEY (CONTINUED)

- If the fireplace is to be installed on an outside wall, the surrounding walls (chase) must be constructed and insulated. See Figure 5. If you do not insulate the fireplace from outside temperatures, heat loss through and around the fireplace will occur.

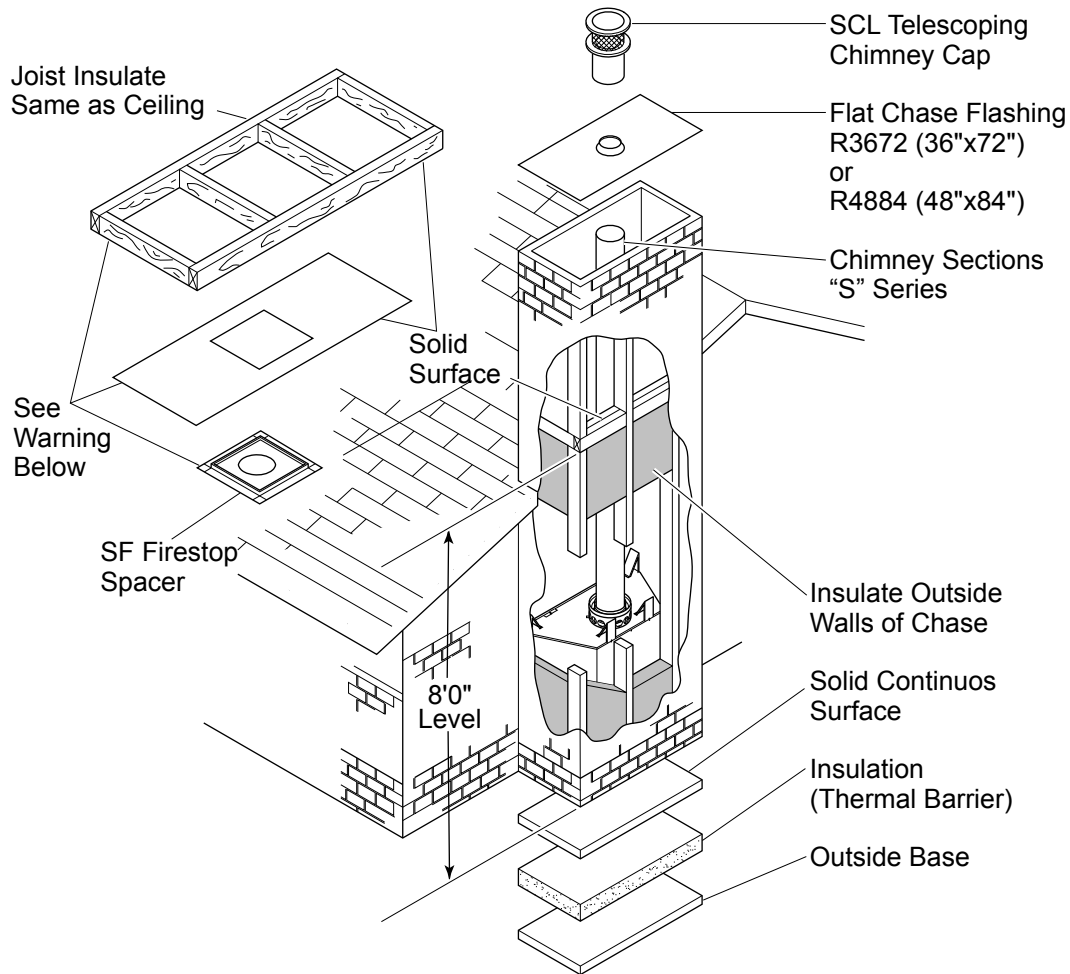

Figure 5 - Installing Fireplace on an Outside Wall

WARNING

- You must use Model SF Firestop
- It is recommended for safety and reducing heat loss that firestopping be used at the ceiling level for chase installation even if local codes do not require firestopping.
- Do not insulate chase with blown or fill type insulation. Only allow insulation to come into contact with fireplace at points where fireplace would normally be contacted by framing materials.

INSTALLING FIREPLACE ON COMBUSTIBLE FLOOR

If fireplace is installed on a combustible floor, protect the floor area either side of the fireplace opening and in the front with an insulating non-combustible hearth extension. (16" [400 unit] or 20" [500 unit] minimum in front of fireplace and 8" minimum on both sides. See Figures 6 through 12.

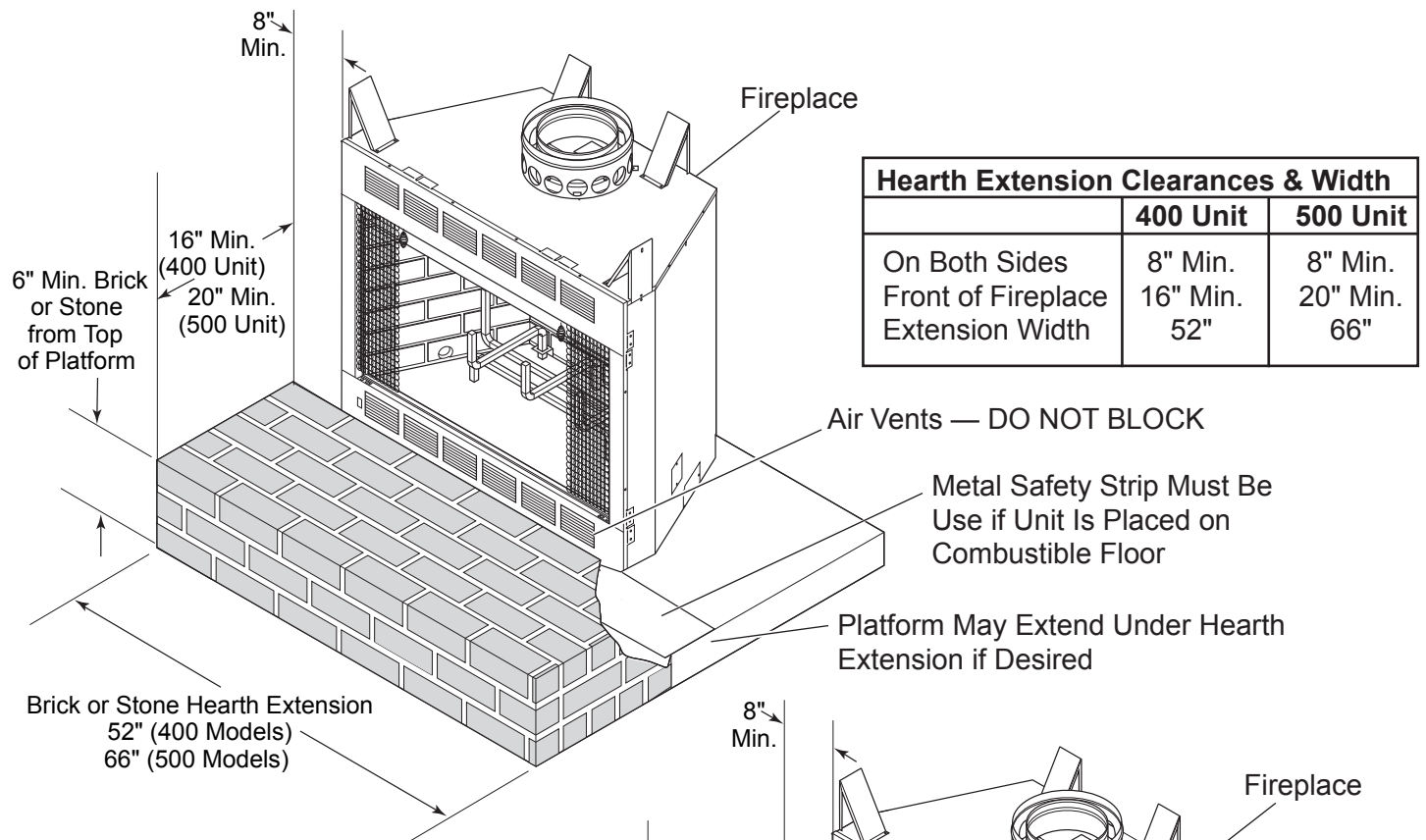

Figure 6 - Installing Floor Protection (Circulating Model)

Note: Do not block the side air vents or air inlet louvers on the lower front of the fireplace with hearth extension.

Air vents and air inlet louvers allow necessary cooling air around the fireplace. Determine the finished height of the hearth extension to be used. Raise the fireplace on a platform, if necessary, to prevent blocking of air openings and lower louvered panel.

Note: No platform is needed if hearth extension does not exceed 1" thick for circulating units or 6½" for radiant units.

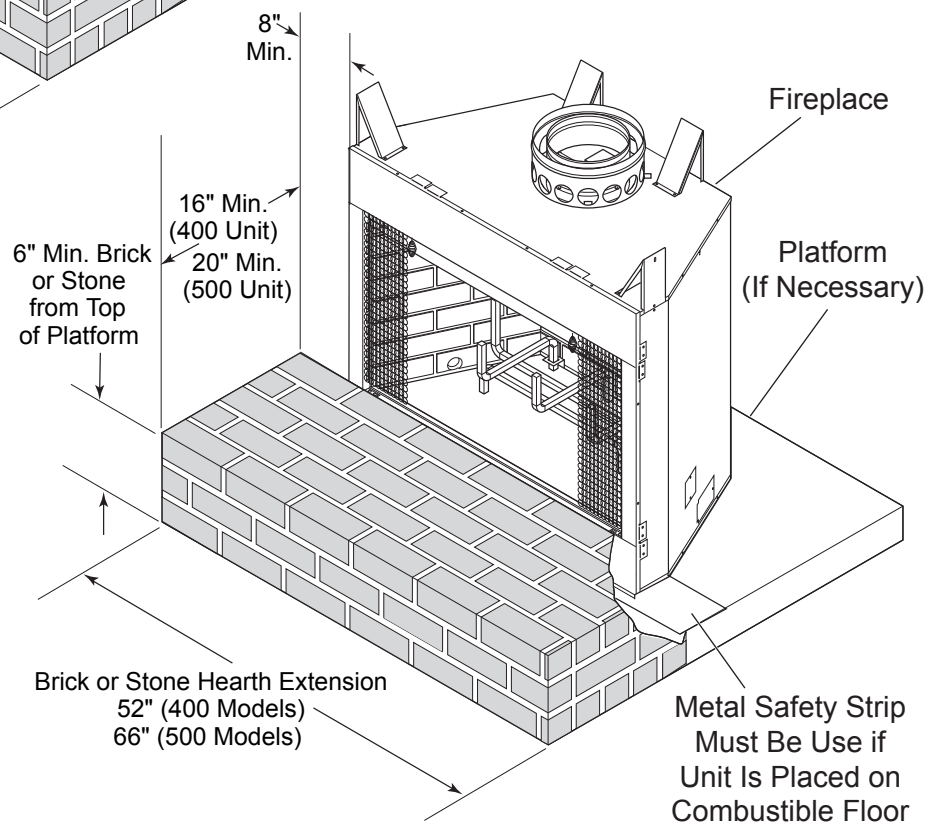

Figure 6 - Installing Floor Protection (Radiant Model)

FLOOR PROTECTION

INSTALLING FIREPLACE ON COMBUSTIBLE FLOOR (CONTINUED)

This hearth extension must be either 6" (minimum) thick stone or brick; a H1652 (400 units) or H2066 (500 units) Hearth Extension Kit; or a locally constructed hearth that has a "K" factor less than .43 and at least 1/2" thick. For other non-combustibles, the total thickness minimum is 1.16 times its thermal conductivity (K).

The following relations could be useful —

$C = K$ divided by the material thickness
 (Example $C = .43$ divided by $1/2$ (.50)
 $C = .86$)

$K = C$ multiplies by the material thickness
 (Example $K = .86$ multiplied by $1/2$ (.50)
 $K = .43$)

$R =$ The material thickness divided by K
 (Example $R = 1/2$ (.50) divided by $.43$
 $R = 1.16$)

$C =$ Thermal Conductant
 $R =$ Thermal Resistance

Minor shifting of the supporting floor or expansion and contraction may eventually cause a crack to develop between the hearth extension and the face of the fireplace with either type hearth extension. To help prevent the cracking, firmly fasten the hearth extension materials in place. Screw wall ties to the face of the fireplace. Imbed the wall ties in the mortar joints of brick, stone, or other non-combustible materials.

Place metal safety strip packed with the fireplace beneath the fireplace. Extend metal safety strip under the hearth extension or into a mortar joint of the hearth. See Figures 6 through 9. If a crack does eventually develop, the metal safety strip will prevent sparks or embers from falling from the fireplace onto combustible flooring materials.

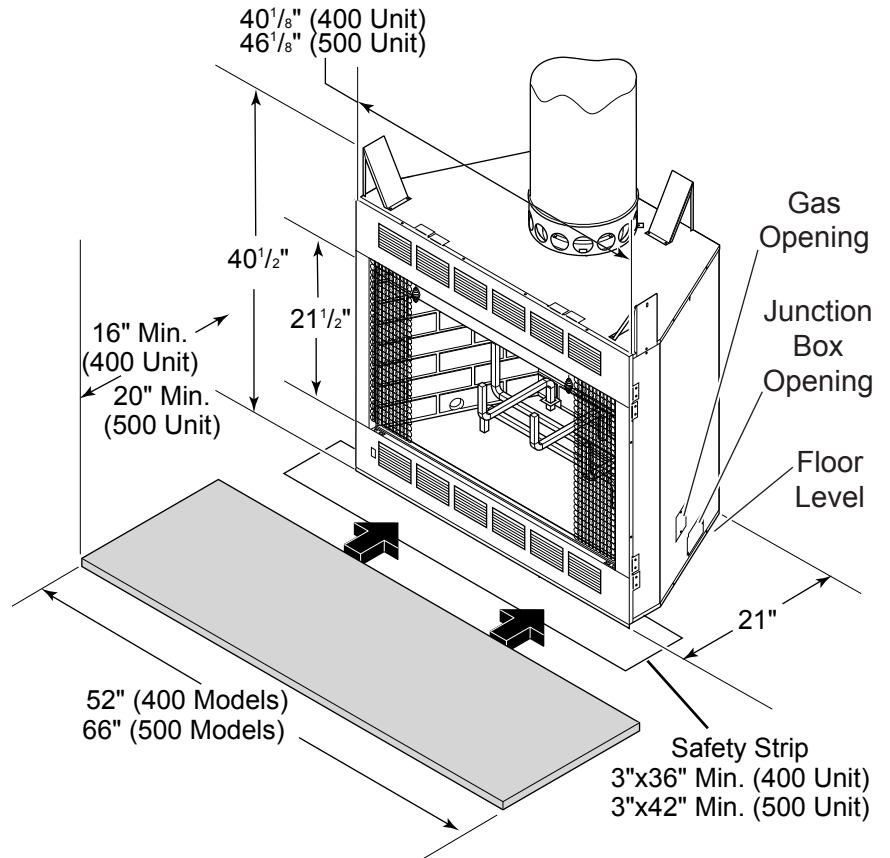

Figure 8 - Installing Hearth Extension (Circulating Model Shown)

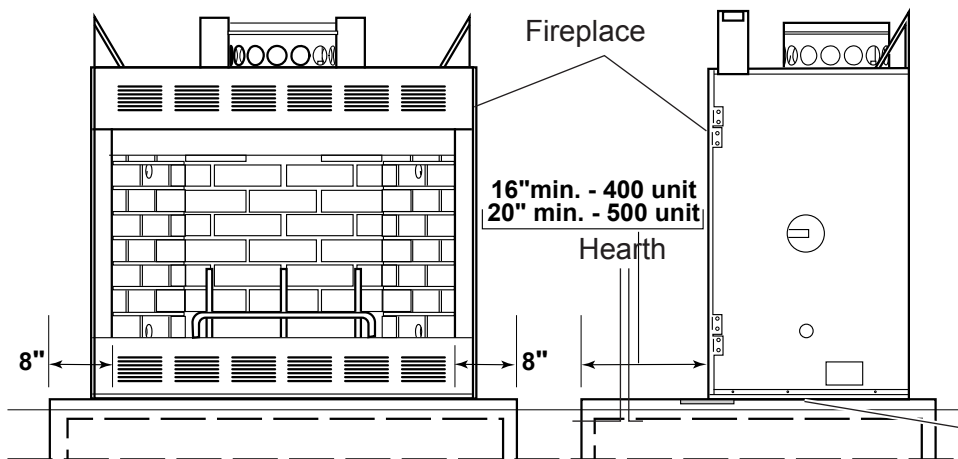

Figure 9 - Installing Hearth Extension and Metal Safety Strip

WARNING Only install metal safety strip horizontal to the fireplace.

Metal Safety Strip

UNPACKING FIREPLACE

Unpack and check the fireplace and chimney for damage. If any items are been damaged or missing, contact your Monessen Hearth Systems dealer. Do not substitute parts. Use only parts listed for use with Monessen Hearth Systems Models BWB400A, BWB400IA, BWBC400A, BWBC400IA, BWB500A, BWB500IA, BWBC500A and BWBC500IA fireplaces.

CLEARANCES

1. Provide required clearances shown in *Figures 10 through 12*. Provide 2" minimum chimney air space clearance to combustibles.
2. Place fireplace in the desired location. Securely support and level fireplace. Check face of the fireplace with a carpenter's level. If fireplace is not plumb, correct it by placing shims under the edges of fireplace.
3. Block in the fireplace to prevent any shifting of firebox. Secure fireplace with nails or screws through the flanges located on each side of the fireplace. Do not enclose the fireplace until the combustion air duct and chimney pipes are installed.

Note: Some local codes may require electrically grounding the fireplace and chimney.

Continued

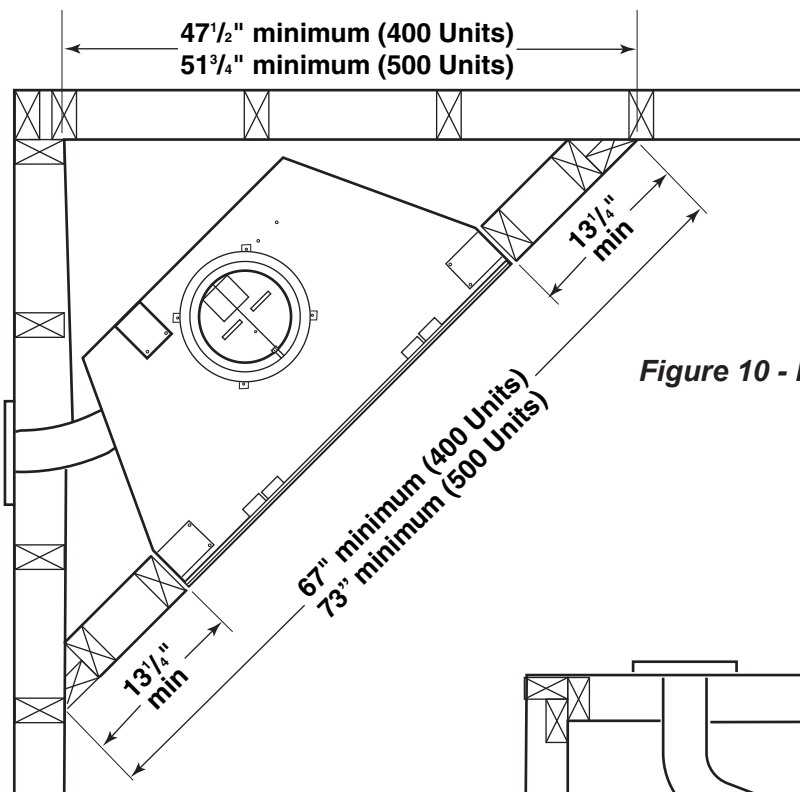

Figure 10 - Minimum Clearances for Corner Installation

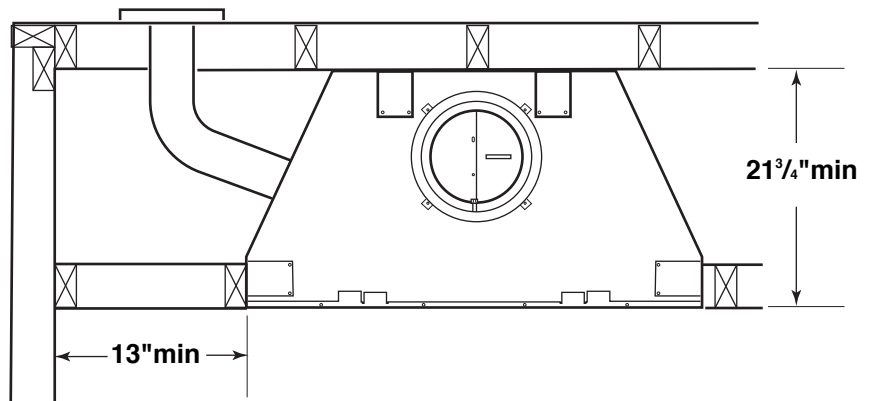

Figure 11 - Minimum Clearances for Wall Installation

FIREPLACE INSTALLATION

CLEARANCES *CONTINUED*

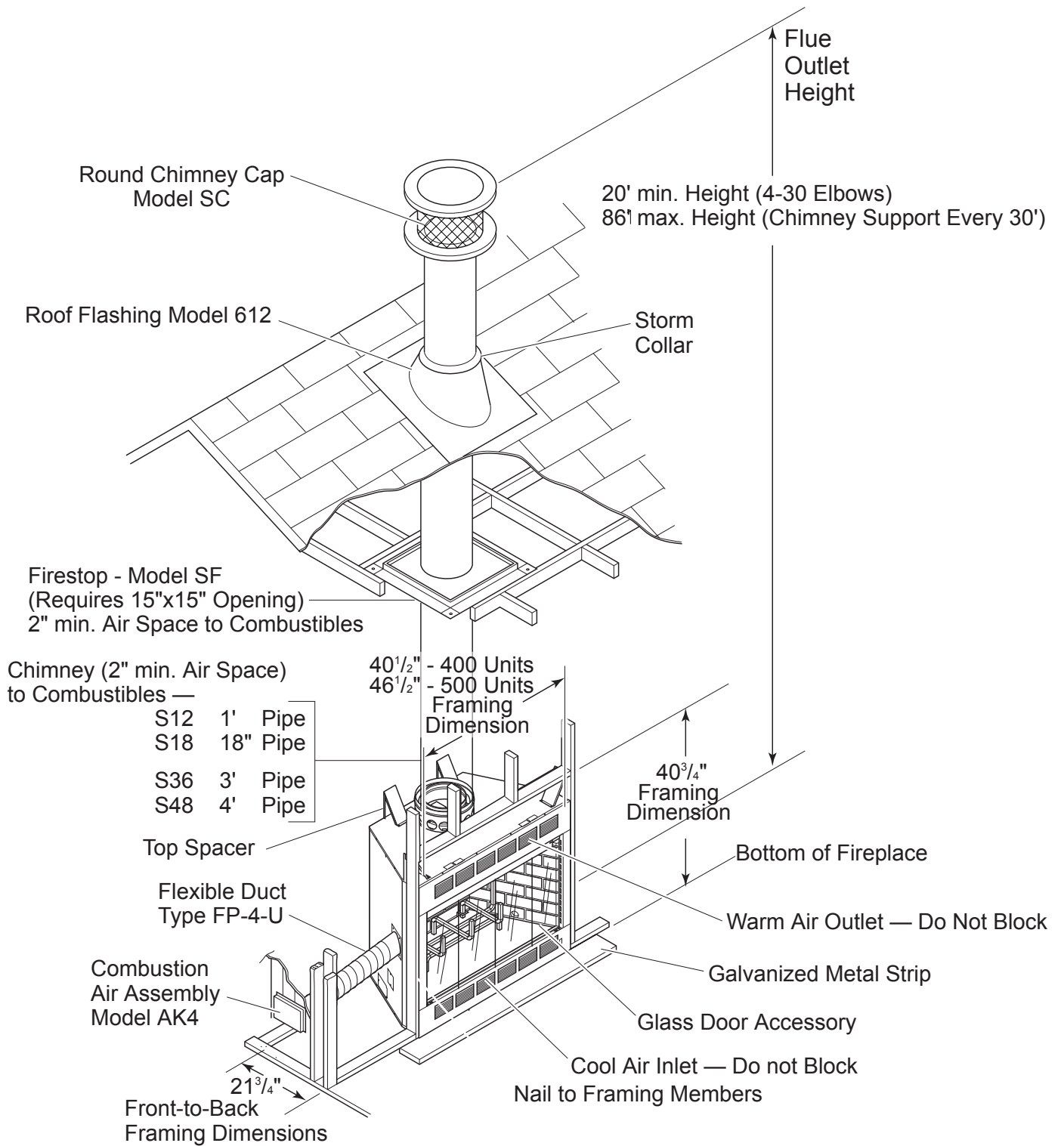

Figure 12 - Proper Clearances and Chimney Height

INSTALLING CHIMNEY SAFETY INFORMATION

You must properly install the chimney to assure safe and satisfactory performance of the fireplace. This is an important part of the installation. Review the Chimney Installation Section thoroughly.

WARNING

For your safety, some of the important things to remember in regard to chimneys are listed below:

- Use only parts and accessories labeled for use with this fireplace.
- Use only undamaged parts and accessories.
- Enclose the chimney where it passes through the living spaces to prevent contact with and possible damage to the chimney.
- Install firestop spacers at each ceiling level.
- Install the proper chimney cap or chimney housing on the chimney to prevent the entry of rain and debris into the chimney and to assure the proper venting of smoke.
- Do not use more than four elbows in the chimney.

Note: To select the proper chimney height, see Figures 12 through 16. The flue outlet must be a minimum of 3' above the highest point where the chimney penetrates the roof and a minimum of 2' above all portions of the building within ten feet. If the chimney is to include elbows to offset the chimney, see Chimney Offset and Cap Installation Section. There must be at least 2" air space between all sections of the chimney and combustible materials between floors.

Do not extend the chimney more than 90" above the roof without additional support.

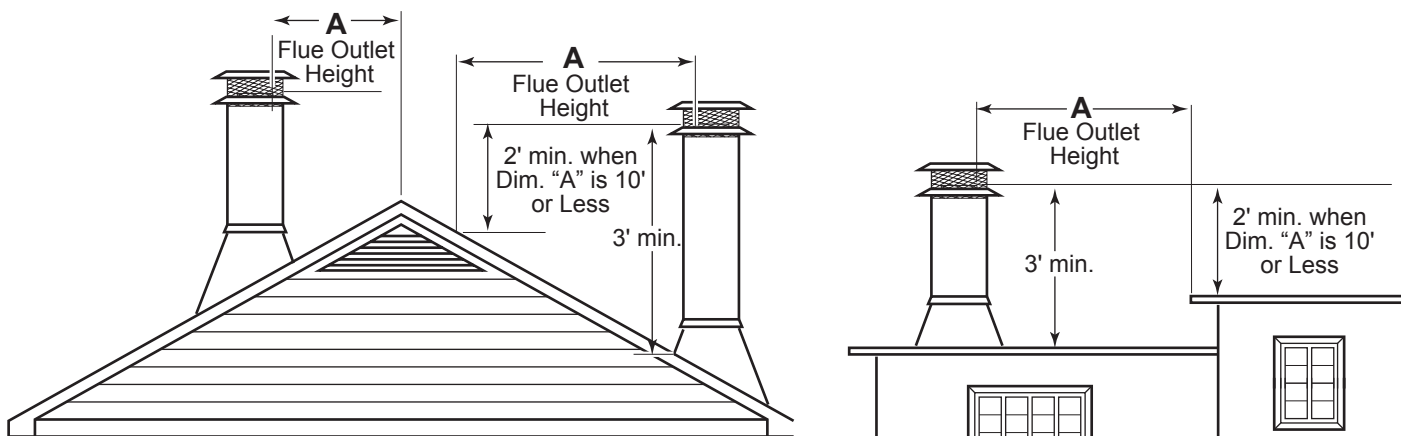

Figure 13 - Proper Chimney Height

CHIMNEY INSTALLATION

INSTALLING CHIMNEY SAFETY INFORMATION (CONTINUED)

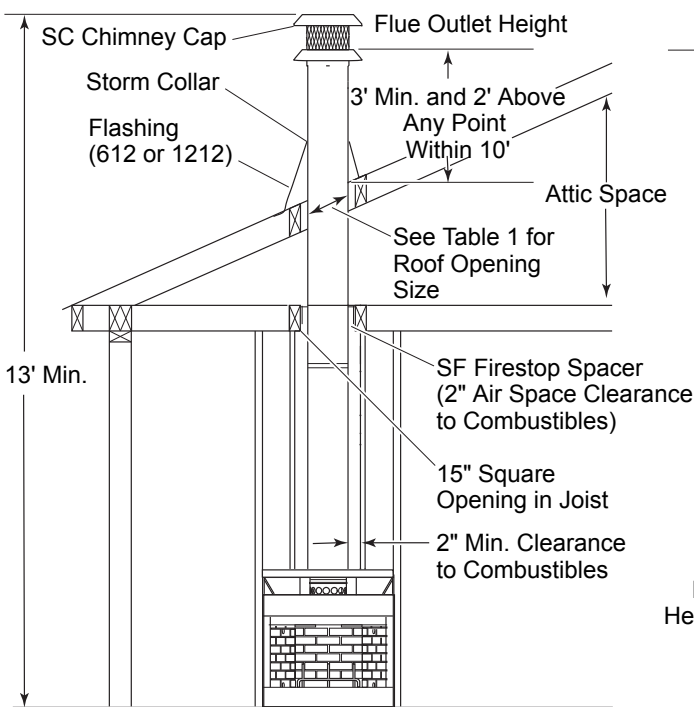

Figure 14 - Proper Chimney Height

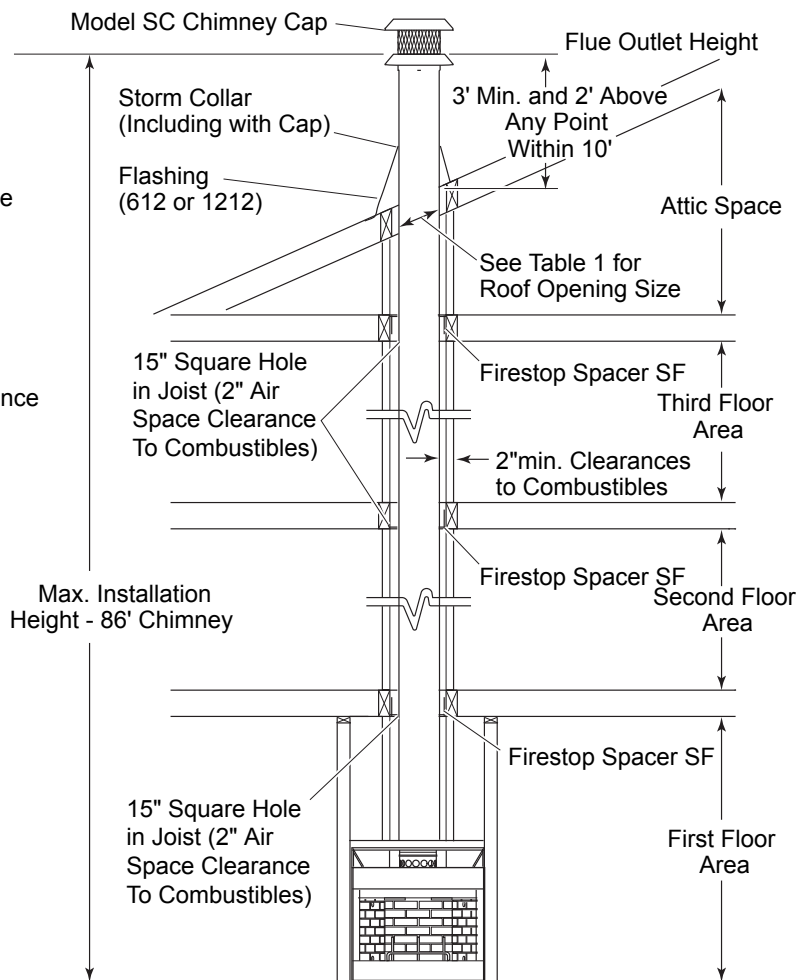

Figure 15 - Residential Installation

Table 1

| Minimum Required Roof Opening Minimum Framed Opening | |
|---|--------------------------------------|
| Roof Pitch | "S" Series Double Wall Chimney |
| 0/12 | 15"x15" |
| 1/12 | 15"x15 ¹ / ₈ " |
| 2/12 | 15"x15 ¹ / ₄ " |
| 3/12 | 15"x15 ¹ / ₂ " |
| 4/12 | 15"x15 ³ / ₄ " |
| 5/12 | 15"x16 ¹ / ₄ " |
| 6/12 | 15"x16 ³ / ₄ " |
| 7/12 | 15"x17 ³ / ₈ " |
| 8/12 | 15"x18" |
| 9/12 | 15"x18 ³ / ₄ " |
| 10/12 | 15"x19 ¹ / ₂ " |
| 11/12 | 15"x20 ³ / ₈ " |
| 12/12 | 15"x21 ¹ / ₄ " |

CAUTION
Do not block air inlets or air outlets

WARNING
Do not install combustible materials below top spacer. Non-combustible materials such as brick or tile may be used to trim face of fireplace. Do not cover any part of louvered panel and cool air inlet. Combustibles must not overlap the black painted face of fireplace.

LOCATING CENTER LINE

You will need to lay out, cut and frame openings through all ceilings and the roof at the point where the chimney will pass through.

Place fireplace in planned position for installation. Unless the chimney is to be offset, the point where the center line of the chimney will pass through the ceiling and roof can be determined with a plumb line. See *Figure 16*. Drive a nail in the center point.

Note: Make sure the chimney location is well away from ceiling and roof joists and/or anything else that might be in the way.

Drive a long nail through the roof from underneath to mark the roof opening center line. Make sure the nail is long enough to go through the roof and be seen on the rooftop. If the chimney is to penetrate a pitched roof, the hole in the roof must be rectangular instead of square and should be sized according to *Table 1*.

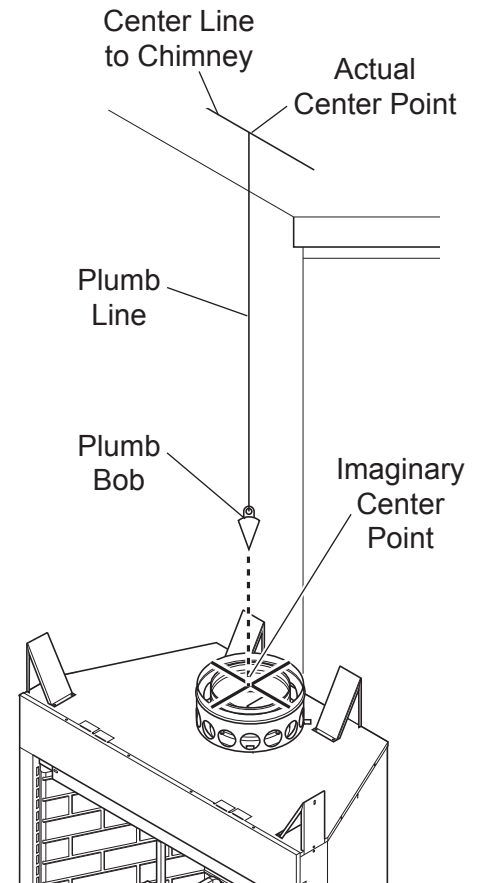

Figure 16 - Dropping Plumb Line from Ceiling

INSTALLING FIRESTOP SPACER

Install the firestop spacer from beneath the ceiling as shown in *Figure 17* unless the space above is attic space.

In an attic, install firestop spacer at the floor level of attic. You must have joists or headers on all four sides of the spacer. Use a minimum of four (4) 8-penny nails to secure the spacer. See *Figure 18*.

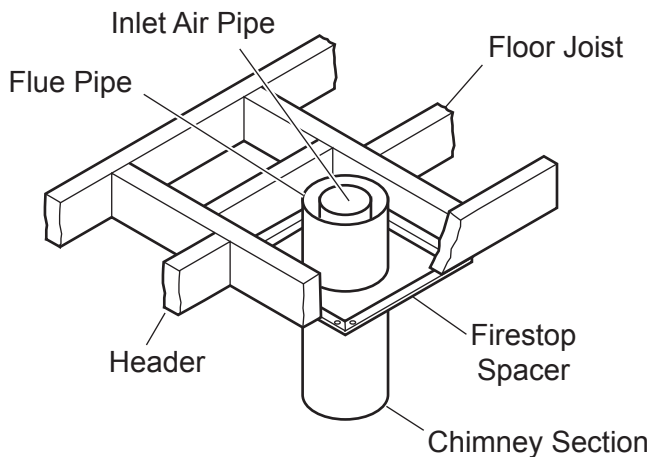

Figure 17 - Installing Firestop Spacer at Floor Level

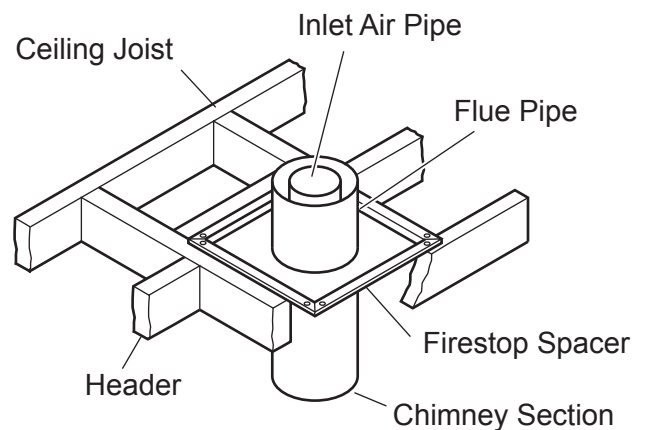

Figure 18 - Installing Firestop Spacer at Attic Level

CHIMNEY INSTALLATION

INSTALLING "S" SERIES CHIMNEY SPACERS

To install the "S" series chimney sections, insert the male end of the flue (the smallest diameter pipe) into the flue outlet of the fireplace. Press down until the snap locks engage. Continue to add chimney sections on top of each other until chimney is at least 6" above roof opening on all sides. See Figure 19.

Note: As the chimney sections are installed, check each joint to make sure it is properly locked to the previous section.

Make outer pipe stronger by using two or three sheet metal screws placed through the area where the outer pipes overlap one another. Carefully drill a $\frac{1}{8}$ " diameter hole through the chimney sections. Do not drill into inner stainless steel flue pipe.

WARNING Be very careful when drilling the holes into the outer pipe. Do not drill into inner stainless steel flue pipe.

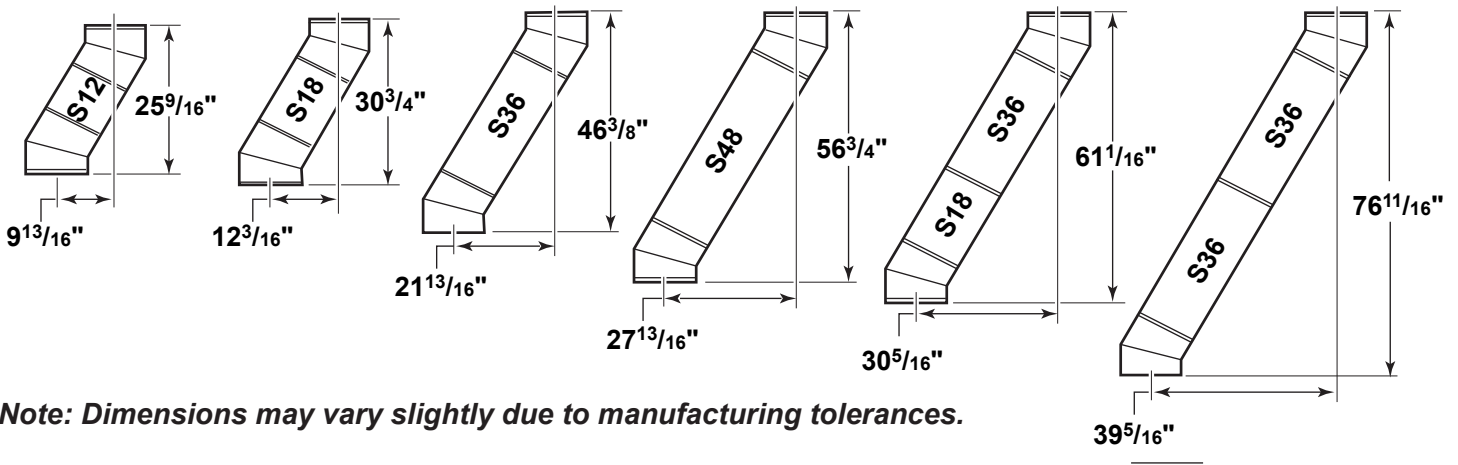

Note: Dimensions may vary slightly due to manufacturing tolerances.

Figure 19 - Chimney Sections for Elbow Offsets

INSTALLING CHIMNEY SUPPORTS

Note: For a total fireplace installation of more than 30' feet, you must use chimney support model SCS at or below 30' to support the weight of additional chimney pipe.

To install the chimney support, place the crimped end of the flue and outlet air duct portions into the last section of chimney pipe. Push down until the outside of inlet air pipe of the chimney support overlaps and snap locks the chimney support into the chimney section.

Nail the support straps tightly to a building frame member or ceiling joist as shown by *Figure 20*. Use at least two (2) 8-penny nails per strap.

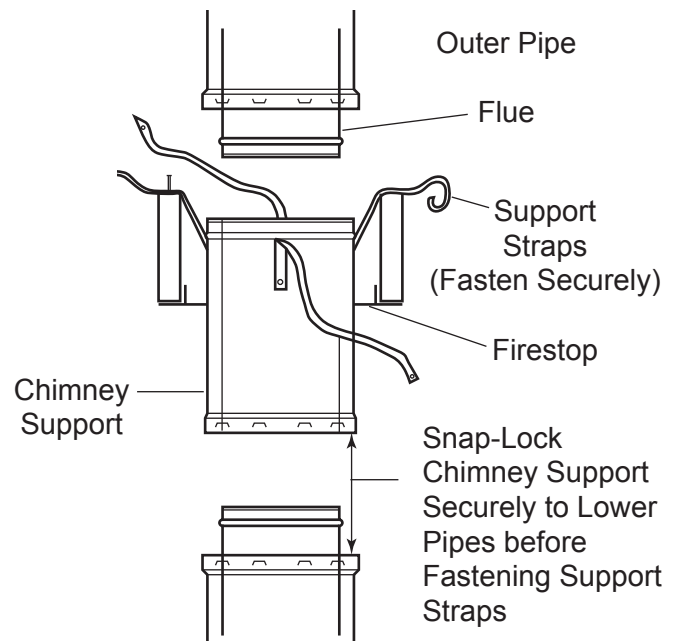

Figure 20 - Installing Chimney Supports

ELBOW INSTALLATION

The following are important points that should be observed when installing elbows on the fireplace.

1. Securely nail down to the surrounding structure support straps of all elbows not installed directly on top of the fireplace. This allows the support strap to carry the weight of the chimney above the elbow and prevents this weight from breaking the elbow or chimney sections apart.
2. Do not use elbows in any combination that inclines the chimney more than 30° from vertical. See *Figure 21*.

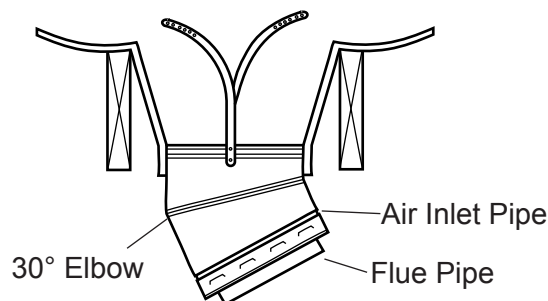

Figure 21 - Elbow Supports

CHIMNEY INSTALLATION

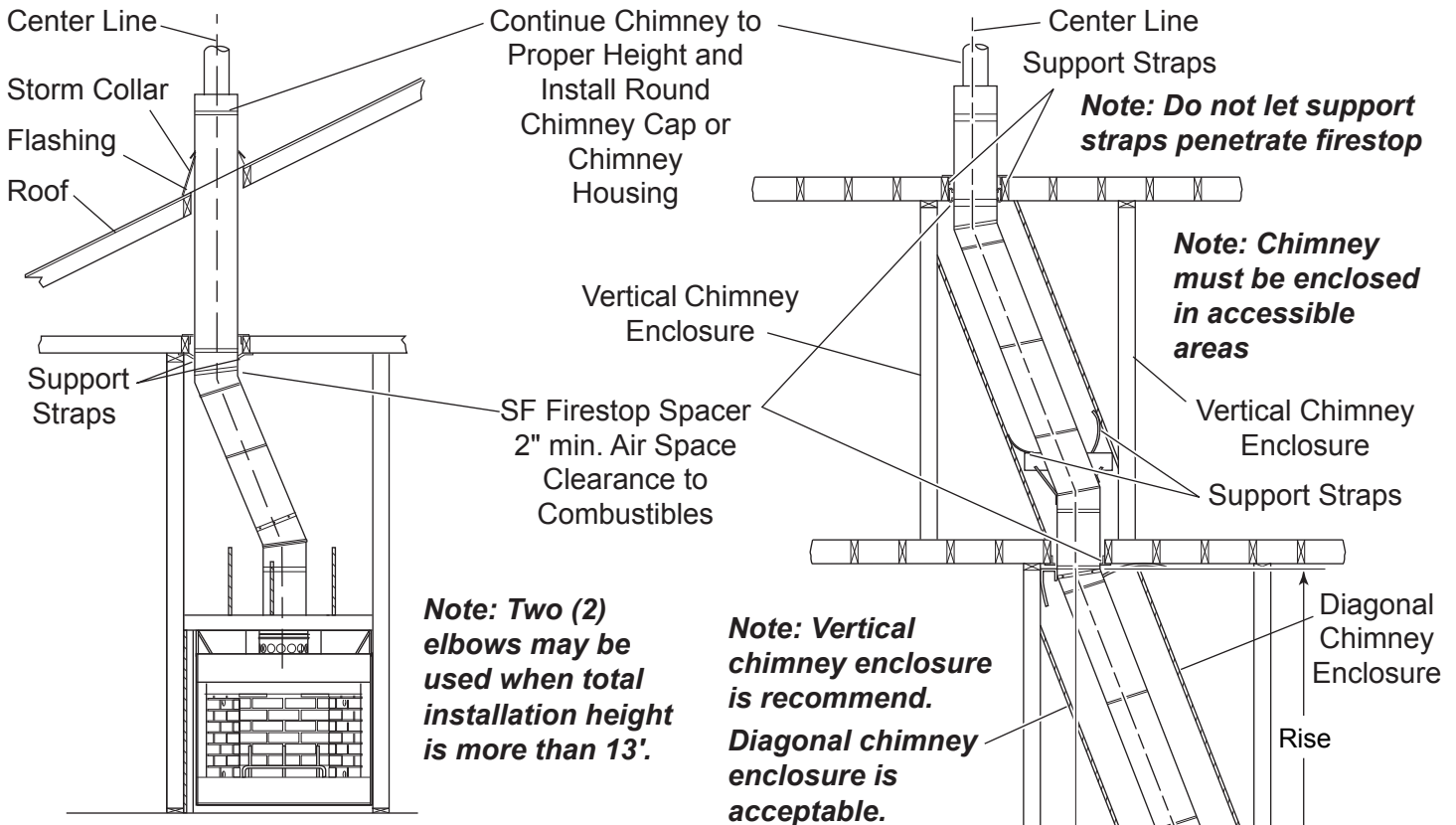

Figure 22 - Installing Chimney with Total Height of Fireplace and Chimney 13' or More

Note: Four (4) elbows may be used when total installation height is more than 20'. Four (4) is the maximum number of elbows allowed.

ELBOW INSTALLATION (CONTINUED)

3. The number of elbows per chimney allowed are as follows:
 If the total height of the fireplace and chimney is 13' 6" or more, two (2) elbows may be used.
 If the total height of the fireplace and chimney is 20' or more, four (4) elbows may be used.
4. Inclined portions of chimney is often used as storage. Enclose the inclined portions of chimney that pass through living spaces to avoid contact with and possible damage to chimney. Maintain minimum air space of 2" between chimney and enclosing. See Figures 22 and 23.
5. The length of inclined portion of chimney between elbows must not exceed 6' if elbows are not supported.
 The length of inclined portion of chimney between elbows must not exceed 20' if elbows are supported every 6' with metal support straps.
6. When enclosing the elbows and inclined portions of the chimney, enclosing materials must be installed vertically to maintain the required 2" minimum air space clearance to the chimney at the extremities of the offset. It is best that enclosing material not follow inclined portions of chimney.

Figure 23 - Installing Chimney with Total Height of Fireplace and Chimney 20' or More

OFFSET INSTALLATION SEQUENCE

Determine the location and amount of offset required. Select the combinations of chimney sections and elbows required from the *Chimney Height and Offset Charts*.

Continued

CHIMNEY HEIGHT CHART (FROM TOP OF UNIT OR FINISHED HEARTH)

| Height (Inches) | Intermediate Sections | | | |
|-----------------|-----------------------|-----|-----|-----|
| | 12" | 18" | 36" | 48" |
| 35 | 0 | 0 | 1 | 0 |
| 39 | 2 | 1 | 0 | 0 |
| 47 | 0 | 0 | 0 | 1 |
| 52 | 0 | 1 | 0 | 0 |
| 58 | 1 | 0 | 0 | 1 |
| 64 | 0 | 1 | 1 | 1 |
| 70 | 0 | 0 | 2 | 0 |
| 75 | 1 | 1 | 0 | 1 |
| 82 | 0 | 0 | 1 | 1 |
| 87 | 0 | 1 | 2 | 0 |
| 94 | 0 | 0 | 0 | 2 |
| 99 | 0 | 1 | 1 | 1 |
| 105 | 0 | 0 | 3 | 0 |
| 111 | 0 | 1 | 0 | 2 |
| 117 | 0 | 0 | 2 | 1 |
| 122 | 0 | 1 | 3 | 0 |
| 129 | 0 | 0 | 1 | 2 |
| 134 | 0 | 1 | 2 | 1 |
| 141 | 0 | 0 | 0 | 3 |
| 146 | 0 | 1 | 1 | 2 |
| 152 | 0 | 0 | 3 | 1 |
| 158 | 0 | 1 | 0 | 3 |
| 164 | 0 | 0 | 2 | 2 |
| 169 | 0 | 1 | 3 | 1 |
| 176 | 0 | 0 | 1 | 3 |
| 181 | 0 | 1 | 2 | 2 |
| 188 | 0 | 0 | 0 | 4 |
| 193 | 0 | 1 | 1 | 3 |
| 199 | 0 | 0 | 3 | 2 |
| 205 | 0 | 1 | 0 | 4 |
| 211 | 0 | 0 | 2 | 3 |
| 216 | 0 | 1 | 3 | 2 |
| 223 | 0 | 0 | 1 | 4 |
| 228 | 0 | 1 | 2 | 3 |
| 235 | 0 | 0 | 0 | 5 |
| 240 | 0 | 1 | 1 | 4 |
| 246 | 0 | 0 | 3 | 3 |
| 252 | 0 | 1 | 0 | 5 |
| 258 | 0 | 0 | 2 | 4 |
| 263 | 0 | 1 | 3 | 3 |
| 270 | 0 | 0 | 1 | 5 |
| 275 | 0 | 1 | 2 | 4 |
| 282 | 0 | 0 | 0 | 6 |
| 287 | 0 | 1 | 1 | 5 |
| 293 | 0 | 0 | 3 | 4 |
| 293 | 1 | 0 | 0 | 6 |
| 305 | 0 | 0 | 2 | 5 |
| 310 | 0 | 1 | 3 | 4 |
| 317 | 0 | 0 | 1 | 6 |
| 322 | 0 | 1 | 2 | 5 |
| 329 | 0 | 0 | 0 | 7 |

| Height (Inches) | Intermediate Sections | | | |
|-----------------|-----------------------|-----|-----|-----|
| | 12" | 18" | 36" | 48" |
| 334 | 0 | 1 | 1 | 6 |
| 340 | 0 | 0 | 3 | 5 |
| 346 | 0 | 1 | 0 | 7 |

| Height (Inches) | Intermediate Sections | | | |
|-----------------|-----------------------|-----|-----|-----|
| | 12" | 18" | 36" | 48" |
| 352 | 0 | 0 | 2 | 6 |
| 357 | 0 | 1 | 3 | 5 |
| 364 | 0 | 0 | 1 | 7 |
| 369 | 0 | 1 | 2 | 6 |
| 376 | 0 | 0 | 0 | 8 |

CHIMNEY SECTIONS WITH ELBOW OFFSETS

| Elbow Set | Chimney Sections | | | | Total Inches OffSet | Total Inches Rise |
|-----------|------------------|-----|-----|-----|---------------------------------|---------------------------------|
| | 12" | 18" | 36" | 48" | | |
| 1 | 0 | 0 | 0 | 0 | 4 ¹ / ₂ | 17 |
| 1 | 1 | 0 | 0 | 0 | 10 | 26 ¹ / ₂ |
| 1 | 0 | 1 | 0 | 0 | 13 | 31 ³ / ₄ |
| 1 | 2 | 0 | 0 | 0 | 15 ¹ / ₂ | 36 |
| 1 | 1 | 1 | 0 | 0 | 15 ¹ / ₂ | 41 ¹ / ₄ |
| 1 | 0 | 0 | 1 | 0 | 22 | 47 ¹ / ₄ |
| 1 | 2 | 1 | 0 | 0 | 24 | 50 ³ / ₄ |
| 1 | 0 | 0 | 0 | 1 | 28 | 57 ³ / ₄ |
| 1 | 20 | 1 | 1 | 0 | 30 ¹ / ₂ | 62 |
| 1 | 1 | 0 | 0 | 1 | 33 ¹ / ₂ | 67 ³ / ₄ |
| 1 | 0 | 1 | 0 | 1 | 36 ¹ / ₂ | 72 ¹ / ₂ |
| 1 | 0 | 0 | 2 | 0 | 39 ¹ / ₂ | 77 ¹ / ₂ |
| 1 | 1 | 1 | 0 | 1 | 42 | 82 |
| 1 | 0 | 0 | 1 | 1 | 45 ¹ / ₂ | 88 |
| 1 | 0 | 1 | 2 | 0 | 48 | 92 ¹ / ₄ |
| 1 | 0 | 0 | 0 | 2 | 51 ¹ / ₂ | 98 ¹ / ₂ |
| 1 | 0 | 1 | 1 | 1 | 54 | 102 ³ / ₄ |
| 1 | 0 | 0 | 3 | 0 | 57 | 107 ³ / ₄ |
| 1 | 0 | 1 | 0 | 2 | 60 | 113 ¹ / ₄ |
| 1 | 0 | 0 | 2 | 1 | 63 | 118 ¹ / ₄ |
| 1 | 0 | 1 | 3 | 0 | 65 ¹ / ₂ | 122 ¹ / ₂ |
| 1 | 0 | 0 | 1 | 2 | 69 | 128 ³ / ₄ |
| 1 | 0 | 1 | 2 | 1 | 71 ¹ / ₂ | 133 |
| 1 | 0 | 0 | 0 | 3 | 75 | 139 ¹ / ₄ |
| 1 | 0 | 1 | 1 | 2 | 77 ¹ / ₂ | 143 ¹ / ₂ |
| 1 | 0 | 0 | 3 | 1 | 80 ¹ / ₂ | 143 ¹ / ₂ |
| 1 | 0 | 1 | 0 | 3 | 83 ¹ / ₂ | 154 |
| 1 | 0 | 0 | 2 | 2 | 86 ¹ / ₂ | 159 |
| 1 | 0 | 1 | 3 | 1 | 89 | 163 ¹ / ₄ |
| 1 | 0 | 0 | 1 | 3 | 92 ¹ / ₂ | 169 ¹ / ₂ |
| 1 | 0 | 1 | 2 | 2 | 95 | 173 ³ / ₄ |
| 1 | 0 | 0 | 0 | 4 | 98 ¹ / ₂ | 180 |
| 1 | 0 | 1 | 1 | 3 | 101 | 184 ¹ / ₄ |
| 1 | 0 | 0 | 3 | 2 | 104 | 189 ¹ / ₄ |
| 1 | 0 | 1 | 0 | 4 | 107 | 194 ³ / ₄ |
| 1 | 0 | 0 | 2 | 3 | 110 | 199 ³ / ₄ |
| 1 | 0 | 1 | 3 | 2 | 112 ¹ / ₂ | 204 |
| 1 | 0 | 0 | 1 | 4 | 116 | 210 ¹ / ₄ |
| 1 | 0 | 1 | 2 | 3 | 118 ¹ / ₂ | 214 ¹ / ₂ |
| 1 | 0 | 0 | 0 | 5 | 122 | 220 ³ / ₄ |

STRAIGHT RUN CHIMNEYS

Chimney support is required at 25' chimney height.

CHIMNEYS WITH ELBOW OFFSETS

The length of the inclined portion of the chimney between elbows must not exceed 6' when unsupported.

The length of the inclined portion of the chimney between elbows must not exceed 20' if the chimney is supported at 6' intervals using either metal support straps or an SCS chimney support.

The SCS chimney support when installed at a 30° angle will add 8' of rise and 4⁵/₈" of offset to the chimney height calculations.

CHIMNEY INSTALLATION

OFFSET INSTALLATION SEQUENCE (CONTINUED)

1. Install the first SE30 elbow by placing the extended flue into the mating part of the fireplace or chimney section. Push down until the outside of inlet air duct of the elbow overlaps. Snap lock the elbow into the fireplace or chimney section.
2. Nail the support straps to the framing member with a minimum of two (2) 8-penny nails per strap.
3. Install the sections of pipe between elbows until the proper number of chimney sections have been installed.
4. Install the second elbow to return the run of the chimney to vertical.
5. Nail the support straps of the second elbow to a building frame member.
6. Continue installing the vertical portion of the chimney. See Figures 22 and 23.

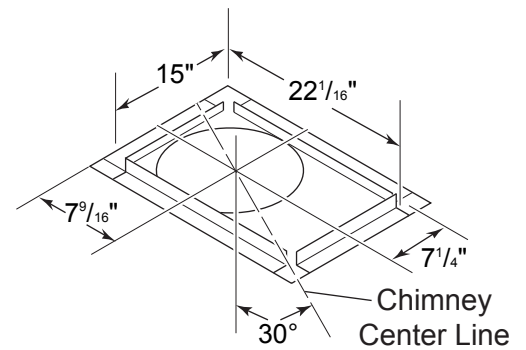

Figure 23 - SF30 Firestop Spacer

Note: If the inclined portion of the chimney passes through a floor or ceiling, an SF30 firestop spacer should be installed to provide the firestop and support required. Be sure proper spacing is maintained between the chimney and combustibles. See Figure 23.

CHIMNEY CAP INSTALLATION

MODEL SC CHIMNEY CAP

Note: The proper chimney height is important to assure proper draft and safety. The chimney cap must extend the flue outlet 4" above the top of the last section of chimney. Keep this mind when determining the proper height for the chimney. The chimney should not be extended more than 90" above the supporting roof structure without additional support. In the case of an "A" frame type construction or other steep pitch roofs that require more than 90" of chimney above the roof, attach a support to the chimney at the 90" level that is strong enough to support a wind load of 3 1/8 pounds for each inch the chimney extends above 90". The flue outlet must be a minimum of 3' above the point where it penetrates the roof. See Figure 24.

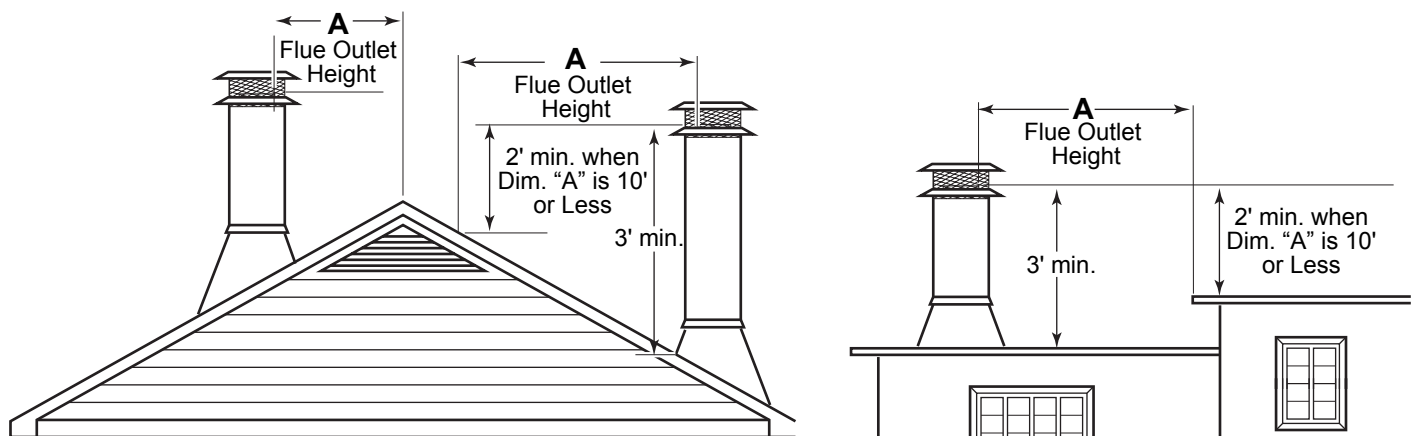

Figure 24 - Proper Chimney Height

CHIMNEY CAP INSTALLATION (CONTINUED)

CAUTION Be careful to avoid electrical shock hazard when contacting wires to the metal chimney components.

1. Extend the regular chimney sections until the top of the chimney is 4" below the total flue height desired. Do not snap the last section of inlet air duct or largest diameter pipe in place until Step 3 is completed.
2. Remove the shingles from around the chimney so that the flashing may be installed. Install the upper part of the flashing under the shingles.
3. Set the flashing on the roof. Scribe a line around the flashing. Cut $\frac{1}{4}$ " below the scribed line. This should increase the diameter of the flashing outlet enough to allow the flashing to be placed over the chimney. See Figure 25.
4. Snap the last section of inlet air duct in place. Slide flashing over the chimney. Check for minimum clearances. Adjust chimney if necessary to make minimum clearances.
5. Nail the flashing securely in place with eight (8) nails.
6. Seal crack between top of flashing and chimney with mastic. Leave some extra mastic at this area to be used in step 8.
7. Place the storm collar around the chimney and put collar together like a belt in belt loops. With the loops facing up, slide the end of collar under the two loops on the other end. Overlap the ends of the collar until it is tight against the chimney. Bend the free end of the collar back over the loops to hold the storm collar securely together. Trim off the excess ends of the storm collar.
8. Slide storm collar down snugly against the flashing until the excess mastic left in step six is forced up into crack between the storm collar and chimney. This will make the joint between the flashing and the chimney watertight. See Figure 26.
9. Place chimney cap into matching parts of the last chimney section. Push chimney cap down until the brackets on the bottom of the chimney cap sits on the chimney pipe. Punch or drill $\frac{1}{8}$ " diameter holes in the inlet air duct (chimney pipe) where specified on the brackets. Fasten chimney pipe down with the No. 8 screws provided. **Note: Do not penetrate the inner stainless steel pipe while installing the screws.**
10. Check all the parts of the fireplace, chimney and chimney termination cap. Make sure none have been damaged or bent during installation. Check to see that all parts have been properly installed.

Note: The metal used for chimney cap has a rust-protective coating but the cut edges of the parts are not protected. Detergent-wash and paint exposed parts of chimney cap with galvanized primer paint. This will prevent rusting and rust staining of nearby structures.

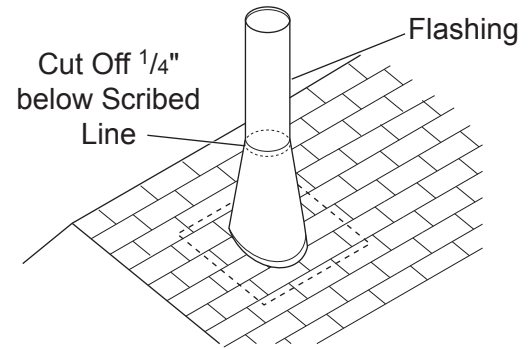

Figure 25 - Cutting Off Top of the Flashing

Note: SCL chimney cap is the same as SC chimney cap except that the SCL cap is a longer telescoping pipe used in special installations (i.e. chase installations)

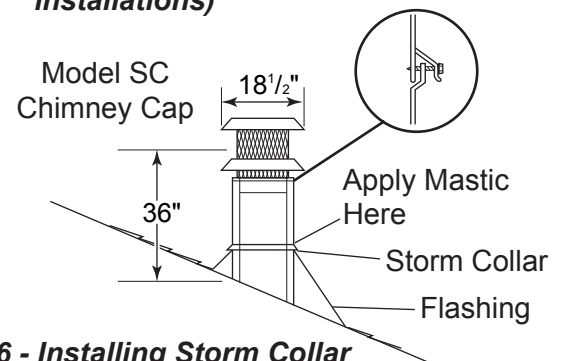

Figure 26 - Installing Storm Collar and Chimney Cap

CAUTION Use pliers and wear gloves when handling the storm collar. The edge of the storm collar is sharp. If you are not careful, you could cut your hands.

CHIMNEY INSTALLATION

CHIMNEY CAP CHASE INSTALLATION

The preinstalled chimney sections must be no more than 10" below the top of the chase. Plan the installation so that either a 2' or 3' chimney section will be used for the top section. This is necessary to completely install inlet air telescope and chimney cap into the top section.

WARNING

Be careful around electrical wires to avoid the electrical shock hazard of contacting the wires with the metal chimney components.

Note: When two fireplace chimneys are terminated above the same chase, the centers of the chimney caps should be at least 24" apart to help prevent smoke from fireplace in use from being drawn down the chimney of fireplace that is not in use. Additional spacing between caps or staggering the height of the caps will also help.

1. Extend the chimney sections until the top of the chimney is not more than 10" below top of the chase.
2. Center the hole in the chase cover over the chimney. Lance and form chase cover overhang over the chase. Secure chase cover overhang with nails. The chase cover overhang keeps water from seeping under the chase cover. If two or more chase cover overhangs are to be used on the same chase, solder the chase covers together to form watertight seams.
3. Place the inlet air telescope inside the hole in the chase cover. Lower inlet air telescope down into the mating pipe of the chimney until flange on the telescope section rest on flange of the chase cover overhang.

Note: All telescoping sections should extend a minimum of 3" inside the mating chimney pipes.

4. Place SCL or SQL8 chimney cap into matching duct telescope and flue telescope of the last chimney section. See Figure 27. Lower the cap until the brackets on the bottom of the chimney cap rests on the raised flange of the flat flashing. Punch or drill $\frac{1}{8}$ " diameter holes in the raised flange of the flat flashing. Fasten cap to the flashing with the No. 8 screws provided.
5. Check all parts of the chimney and chimney cap. Make sure none have been damaged or bent during installation. Check to see that all parts have been installed properly.

Note: The metal used for the chimney and chimney cap has a rust-protective coating but the cut edges of the parts are not protected. Detergent-wash and paint exposed parts of the chimney and chimney cap with galvanized primer paint. This will prevent rusting and rust staining of nearby structures.

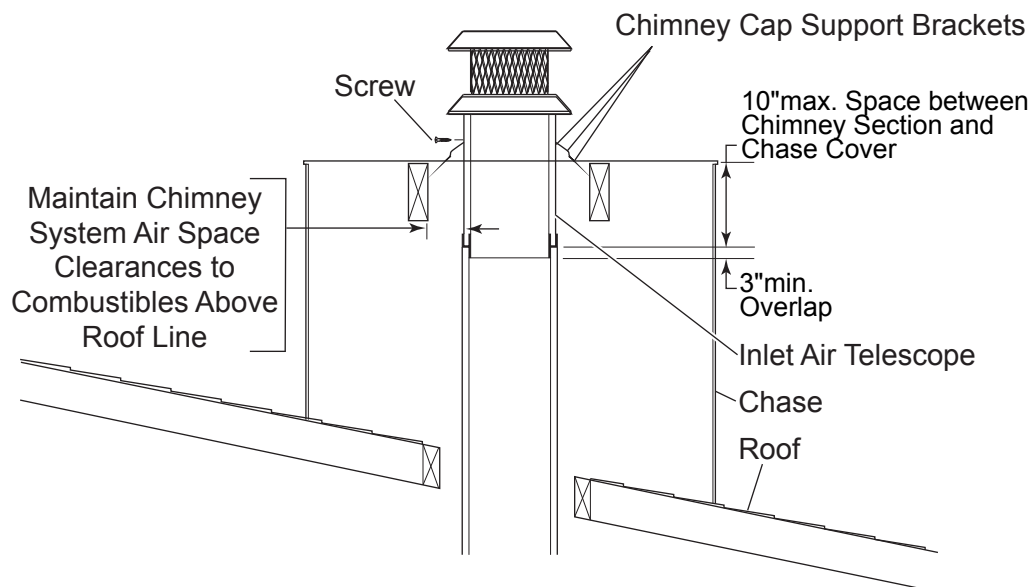

Figure 27 - Installing Chimney Cap Chase

OUTSIDE COMBUSTION AIR PRECAUTIONS AND RECOMMENDATIONS

COMBUSTION AIR

1. Locate combustion air assembly at an exterior location which is not likely to be accidentally blocked in any manner. Locate assembly above the snow line to prevent blockage by snow accumulation.
2. Never mount the combustion air inlet assembly in a garage or storage area where combustible fumes such as gasoline might be drawn into the fireplace.
3. Combustion air can be drawn from the crawl space under a house when an adequate supply of air is provided by open ventilation.
4. Do not take combustion air from attic space or garage space.
5. Avoid extremely long runs and numerous turns in the duct leading from the fireplace to the combustion air assembly. These conditions increase the resistance to the free flow of air through the duct. *See Figures 28 through 31 for methods of installing the outside air for combustion assemblies.*

Continued

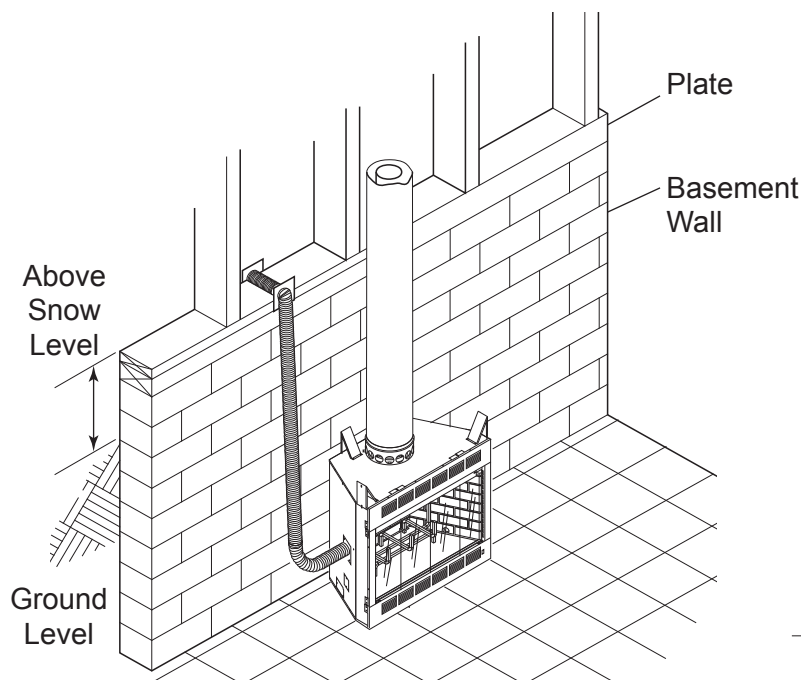
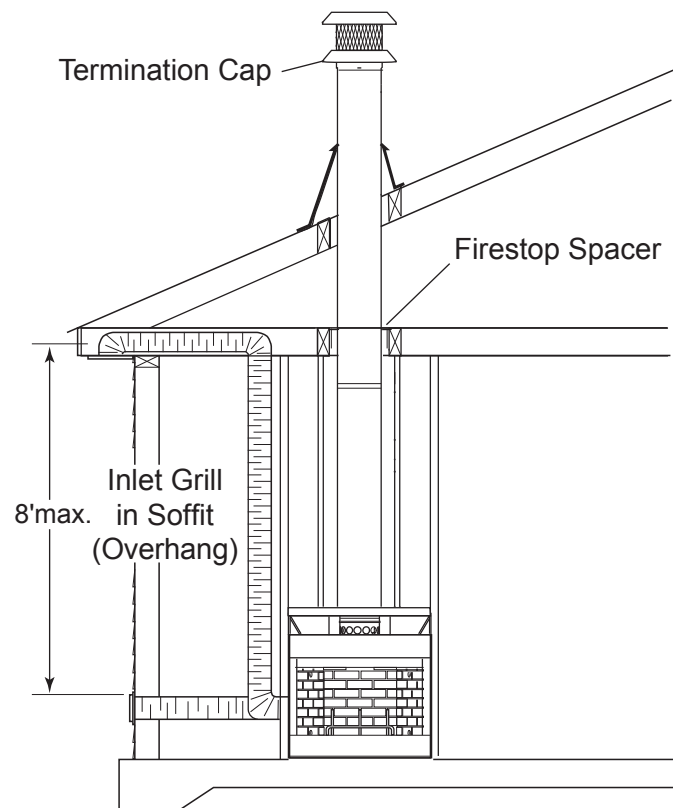

Figure 28 - Basement Installation



**Figure 29 - Concrete Slab Installation
(Optional Outside Air Runs)**

CAUTION

Do not take combustion air from attic space or garage.

OUTSIDE COMBUSTION AIR PRECAUTIONS AND RECOMMENDATIONS

COMBUSTION AIR (CONTINUED)

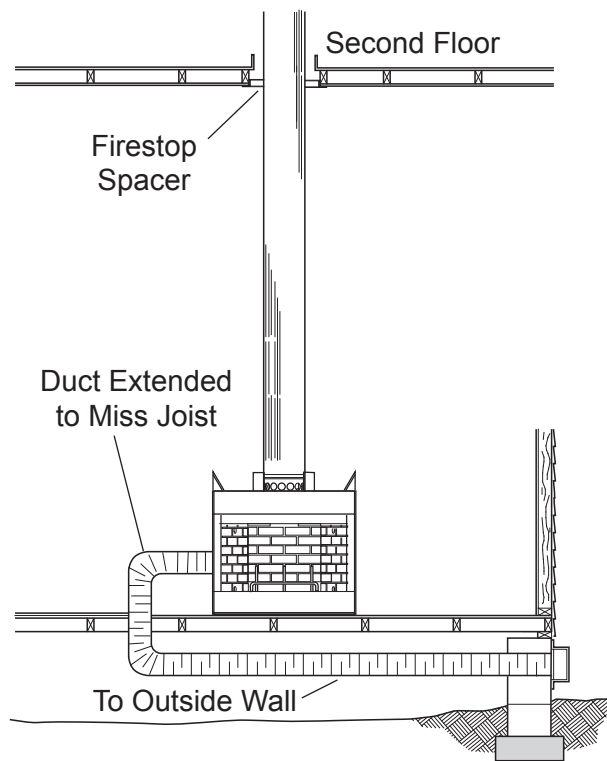

Figure 30 - Installation Above Basement or Crawl Space

CAUTION Do not take combustion air from attic space or garage.

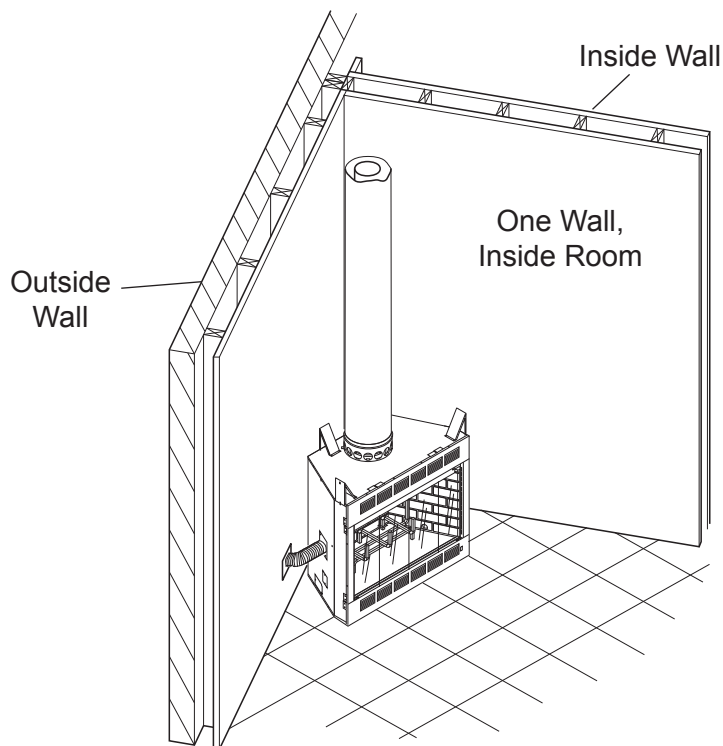

Figure 31 - 45° Corner Installation on Slab Floor

OUTSIDE COMBUSTION AIR PRECAUTIONS AND RECOMMENDATIONS

The use of outside air for combustion is optional unless required by building codes. It is only necessary to supply outside combustion air to one side of the fireplace. Use the model AK4 combustion air kit.

MODEL AK-4 COMBUSTION AIR ASSEMBLY

1. Remove the cover plate from the 4" outlet opening location on the left or right outside of the fireplace.
2. Place the insulation ring between the AK-4 starting collar and fireplace wall.
3. Place the starting collar (4") into the hole on the side of fireplace. Fasten it in place with the four sheet metal screws provided. *See Figures 32 and 33.*

Note: The air starting collar extends through the fireplace outer wrap. When the air starting collar is securely attached, it will form a seal against the fireplace wall.

4. Attach outside duct to starting collar with duct clamp or screws. *See Figure 33.*

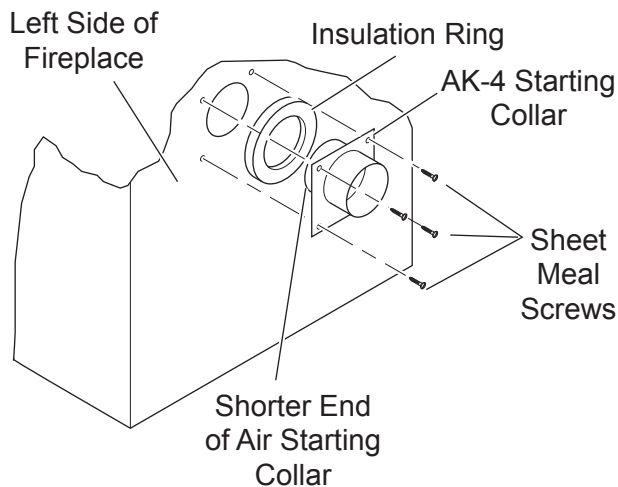

Figure 32 - Attaching Outside Air Starting Collar and Insulation Ring to Left Side of Fireplace

5. Cut a 6-inch diameter opening for model AK-4 in the outside wall covering where the outside vent is to be located. *See Figure 34.*
6. Select and cut a piece of duct long enough to attach to the fireplace and stick out at least 3" beyond the face of the wall to which the AK-4 inlet air vent will be attached. Cut duct with a standard pocket knife. *See Figure 33.*

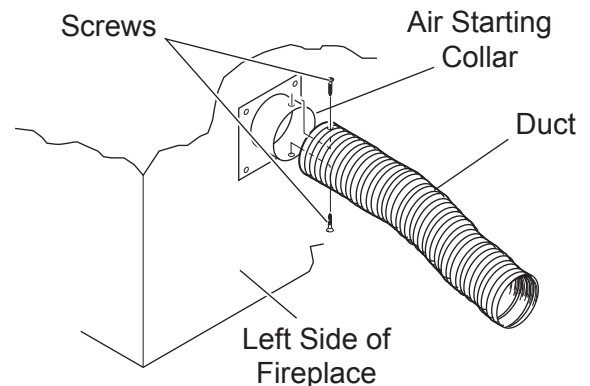

Figure 33 - Attaching Outside Duct to Starting Collar

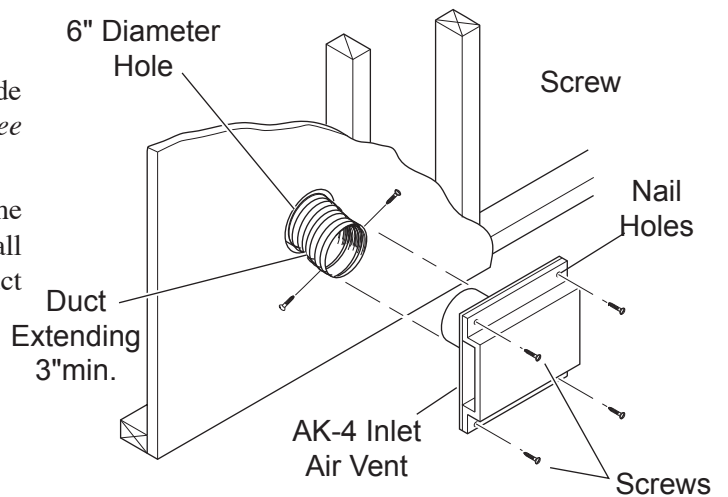

Figure 34 - Combustion Air Assembly for Model No. AK-4

WARNING

Use FP-4 U duct for maximum efficiency and safety. Do not use a combustible duct. Always use UL Listed Class 0 or 1 duct material.

Continued

OUTSIDE COMBUSTION AIR PRECAUTIONS AND RECOMMENDATIONS

MODEL AK-4 COMBUSTION AIR ASSEMBLY (CONTINUED)

7. If the duct is the insulated type, push the insulation back from one end of the duct approximately 2". See Figure 35.
8. Slip the exposed end of the duct over the starting collar on the fireplace.
9. Using the sheet metal screws provided, secure the duct end to the collar attached to the fireplace.
10. Nail or screw the combustion air assembly to the surface of the wall.

Note: If the wall covering is brick or stone, use appropriate masonry fasteners. Mount combustion air assembly with "TOP" upward to prevent cold air from entering through the wall. If necessary, splice the duct. Use a model 403-duct connector to splice duct sections.

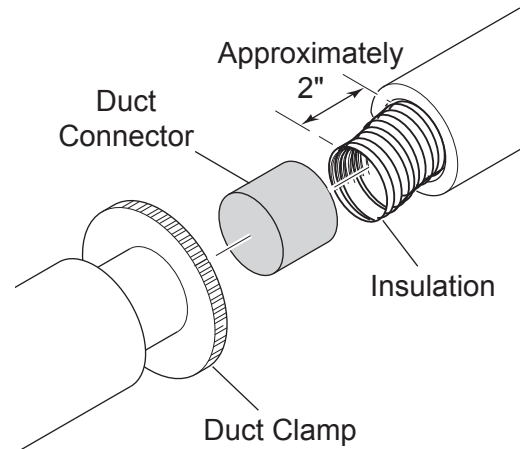

Figure 35 - Installing Duct Connector 403

INSTALLING MODEL 403 DUCT CONNECTOR

1. Push insulation back approximately 2" from the end of each duct.
2. Slip each duct over duct connector until an equal length of connector extends into each duct.
3. Place duct clamp over the end of each duct. Tighten duct clamp down snugly.
4. Push insulation back into place and over duct clamp.

GAS APPLIANCE INSTALLATION

DANGER Improper installation or operation of a gas appliance in this fireplace can allow unburned gas to leak out which will cause a fire or explosion hazard, or the release of poisonous carbon monoxide into the dwelling which can cause serious injury or death to its inhabitants.

To reduce these risks to a minimum, read and follow the following important notices and instructions carefully.

1. The provision for a gas line is intended for connection to a decorative gas appliance which has an automatic shutoff device and complies with the Standard for Decorative Gas Appliances for Installation in Vented Fireplaces, ANSIZ21.60. If a decorative gas appliance is installed, it must be installed in accordance with the National Fuel Gas Code, ANSIZ223.1.

WARNING Keep fireplace damper fully opened at all times when using a decorative VENTED gas appliance.

Continued

CAUTION If an unvented gas appliance is installed in the fireplace, the gas appliance must only be operated with the fireplace glass door fully open (if included). Only unvented gas log sets which have been found to comply with the standard for unvented room heaters, ANSI/IAS/AGA Z21.11.2 are to be installed in this fireplace.

WARNING Do not operate an unvented gas log set in this fireplace with the chimney removed.

2. An approved gas shut off valve must be located outside the fireplace in an area accessible to the users of the fireplace.
3. All gas piping and fitting must be either steel or malleable iron. Unions must be of the ground joint type.
4. Some code authorities prohibit or place restrictions on the use of gas appliances in fireplaces. Check with local code authorities before proceeding with installation.
5. The gas appliance and all connecting gas piping must only be installed by a licensed gas appliance installer. *See Figure 36* for the gas line opening dimensions on the fireplace.
6. The installer of the fireplace and gas appliance must describe the operation of the fireplace and appliance to the people who will be operating them and leave all instruction manuals with the operator of the appliance.

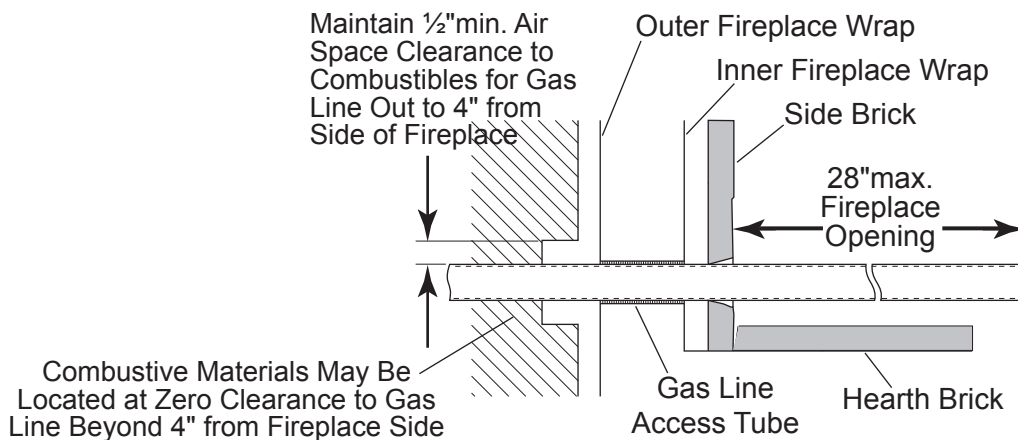

Figure 36 - Gas Line Opening Dimensions

INSTALLING GAS APPLIANCE

PASSING GAS LINE THROUGH FIREPLACE WALL

1. Locate recessed area in side brick side liner.
2. Lightly tap recessed area with a hammer until a round hole is tapped out. *See Figure 37.*
3. Remove the two (2) screws that hold cover plates on jacket wrap. Discard cover plate.
4. Install the gas pipe through the tube between the firebox and jacket.
5. Attach the gas appliance to the gas pipe according to the appliance makers instructions.
6. Pack insulation around the pipe to prevent air flowing through the tube either into or out of the firebox for proper seal.

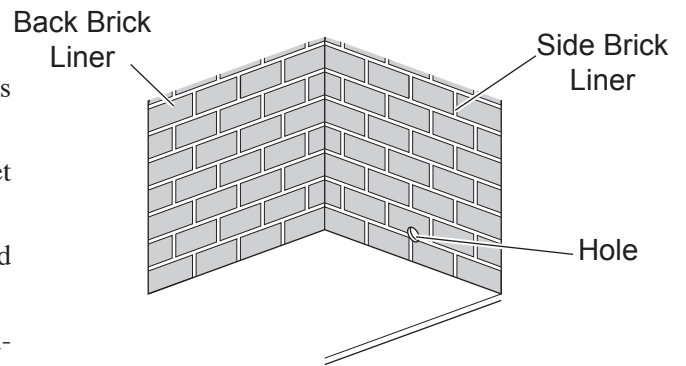

Figure 37 - Hole in Side Brick Liner

WARNING

1. Turn gas off at the appliance.
2. Turn the gas on at the cut off valve.
3. Test the gas line connections for leaks with soapy water solution or a liquid leak detector. **DO NOT USE A MATCH OR OTHER FLAME SOURCE TO CHECK FOR GAS LEAKS.** If a gas leak is detected, turn the gas off immediately. Fix the leak.

7. Follow the instructions provided by the manufacturer for testing and adjusting gas line.

TRIM AND MANTEL INSTALLATION FOR GAS APPLIANCES

Mantel Trim Installation (Unvented Gas Appliances Only)

The fireplace face may be left exposed or trimmed. If trim is installed, fasten it securely to face of fireplace. Trim materials must not extend closer than $\frac{3}{8}$ " to the vertical edge of fireplace opening if you plan to use glass doors.

1. Install hood on fireplace with mantels 12" from the opening of fireplace. Mantel may be no more than 12" deep. Combustible framing members may be placed across top spacers. See *Figure 38*.
2. Combustible mantel and/or trim may be installed within shaded area in *Figure 39*. Use only non-combustible materials below top of spacers and behind front face.

WARNING

Hood (p/n 075629) must be installed when mantel is 12" from fireplace opening.
Note: Glass doors must be removed when using hood.

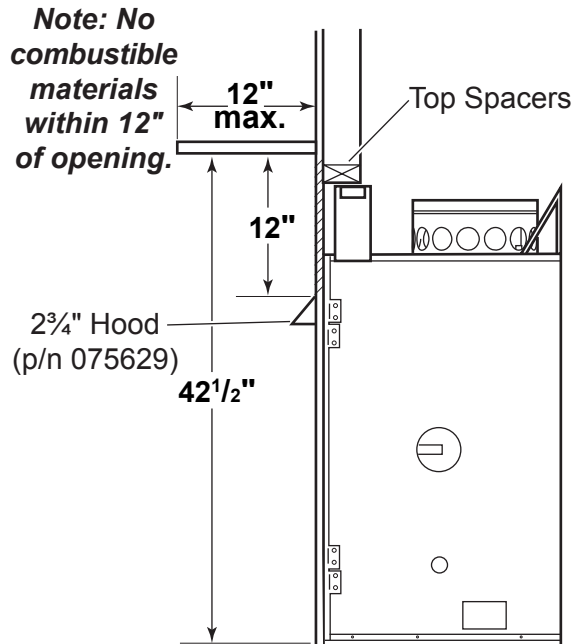

Figure 38 - Locating Mantel 12" from Opening when Using Hood

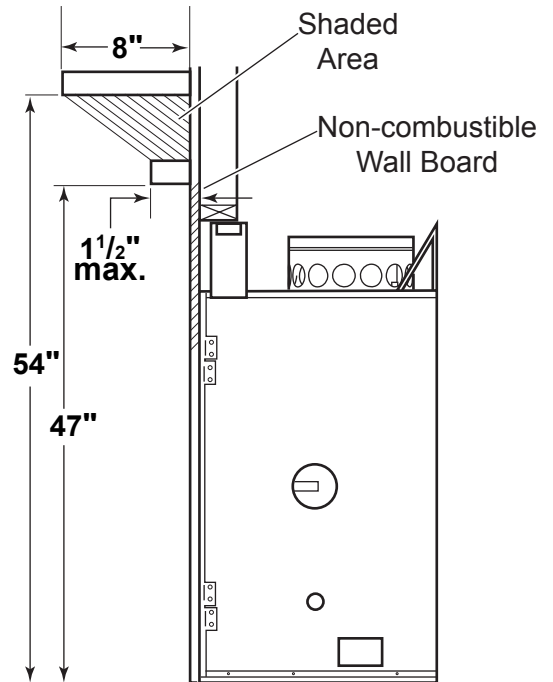

Figure 39 - Placement of Combustible Mantel and Trim without Hood

Note: These instructions are for acceptable combustable mantel location in GAS APPLIANCES ONLY. See Figures 40 through 41 for acceptable combustable mantel locations for wood burning fireplaces.

TRIM AND MANTEL INSTALLATION FOR WOOD BURNING FIREPLACES

- The fireplace face may be left exposed or trimmed. If trim is installed, fasten it securely to face of fireplace. Seal any cracks between trim material and face of fireplace. Cracks can cause a fire and prevent fireplace from working properly.
- Place wall ties in mortar joints of masonry trim. Fasten wall ties to face of fireplace with sheet metal screws.
- Use only non-combustible materials below top of spacers.

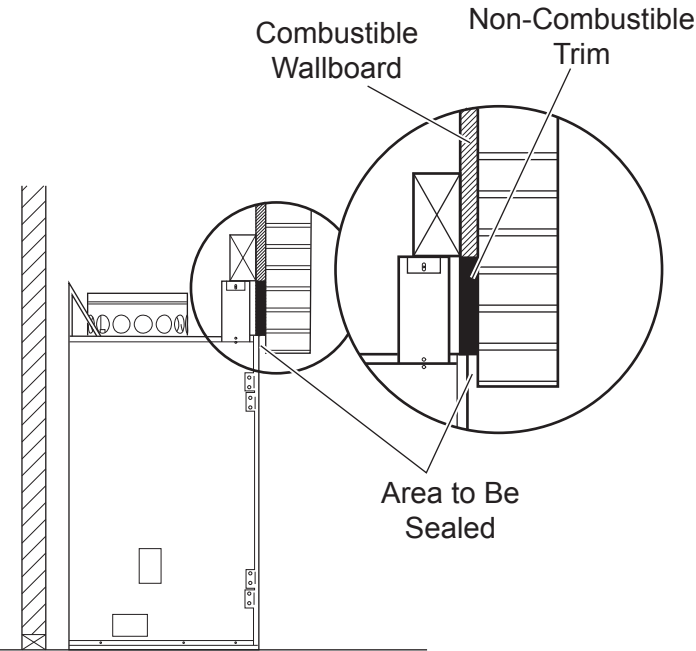

Figure 40 - Spacer Location

LOCATING FRONT AND SIDE CLEARANCES

To find front clearances, extend a line from back corner of unit to 4" in front of fireplace face and 1" outside screened opening. Combustible materials may be placed within shaded areas. **Note: Do not let combustible materials overlap black painted surface more than 1/8". See Figure 41.**

Trim may butt against side walls of fireplace. The other 3 walls must have 3/4" clearances.

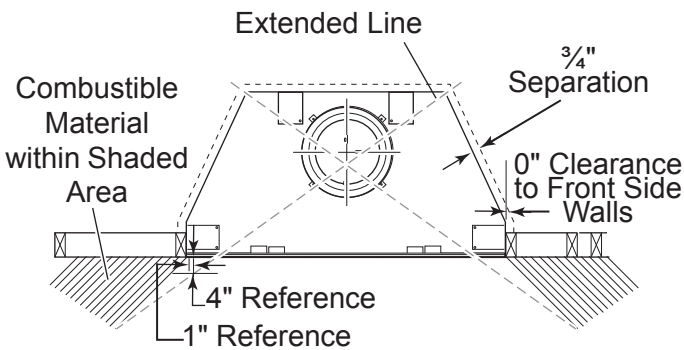

Figure 41 - Front and Side Clearances

WARNING Seal any space between face of fireplace and non-combustible facing material. Failure to seal this crack is a possible fire hazard and will void the warranty.

WARNING Do not cover or restrict side vent areas with surround or trim materials

LOCATING MANTEL

Maximum depth of mantel is 12"

A = 6 1/2" - Minimum from top of fireplace opening to bottom of any combustible trim material sticking out no more than 1 1/2" beyond face of fireplace

B = 12" - Minimum from top of fireplace opening to bottom of combustible trim material sticking out more than 1 1/2" from top of fireplace opening

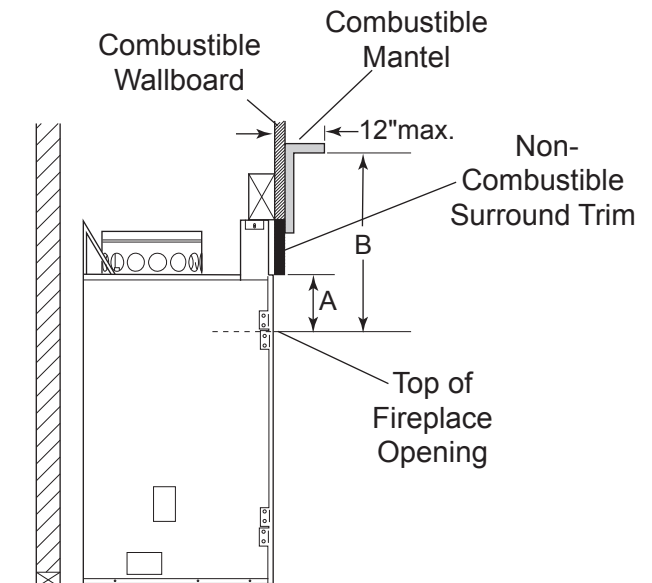

Figure 42 - Locating Mantel

GLASS DOOR INSTALLATION

This fireplace has been tested and listed for use with optional Model GD36BA, BD36PBA, GD36SSA, GD42BA, BD42PBA, and GD42SSA glass doors. For installation of glass doors, see the instructions provided with the doors.

FAN ACCESSORY

The model BWBC400A, BWBC400IA, BWBC500A, and BWBC500IA fireplaces may be equipped with a Model FA2A fan accessory. If the fireplace is to be equipped with the FA2A fan at anytime, the junction box assembly must be installed on the fireplace during fireplace installation. See Figures 43 through 45. If junction box is not installed at this time, wall finishing materials must be removed to gain access to the side of the fireplace to install junction box later.

Note: A rectangular switch knockout is provided on the lower right hand face of the fireplace.

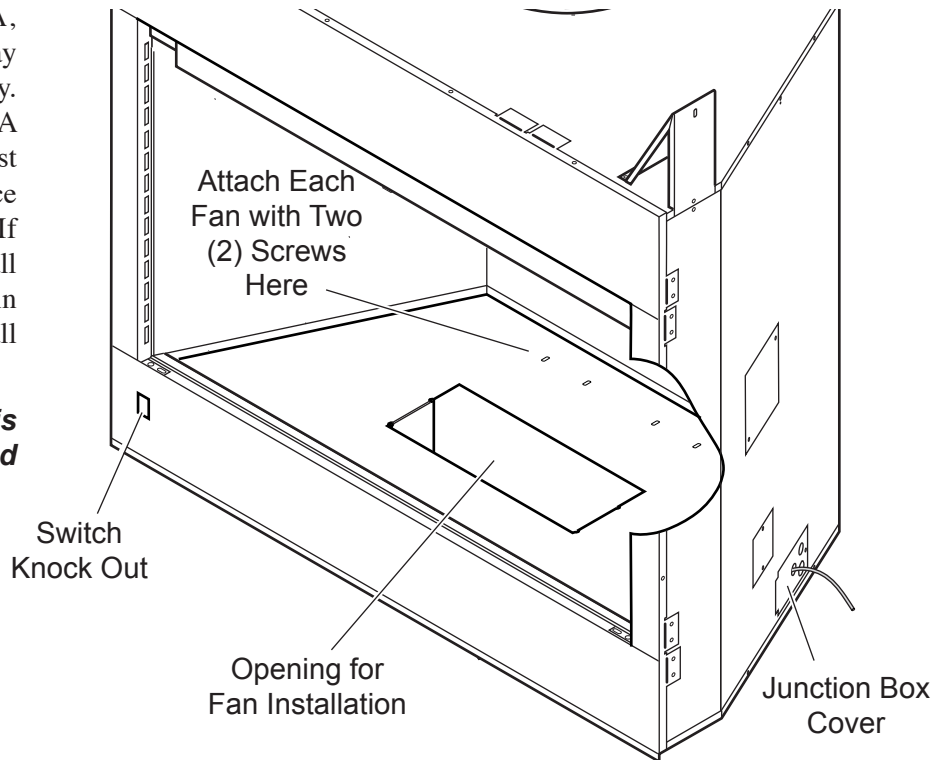

Figure 43 - Blower Location

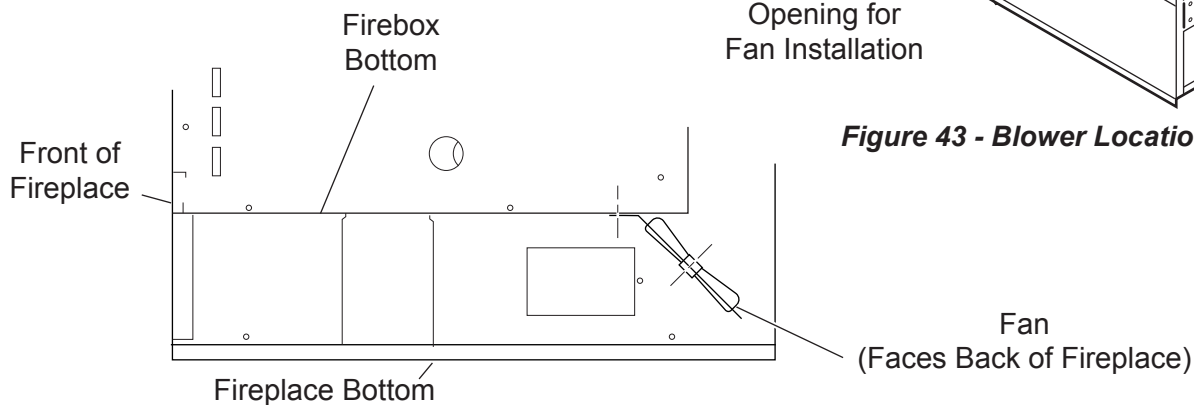

Figure 44 - Blower Location (Side View)

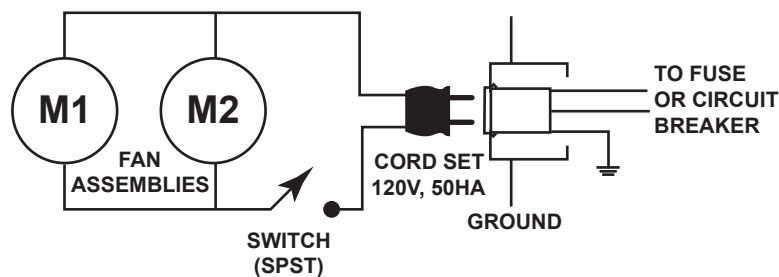

Figure 45 - Wiring Diagram

FIREPLACE OPERATION

WARNING

Fireplace damper must be fully opened when using a gas appliance.

See *Gas Appliance Installation* for more guidelines.

ADVANTAGES OF A WOOD BURNING FIREPLACE

These are practical and ecological advantages of using wood as a fuel. Also to be considered is the aesthetic appeal. Most of us consider a wood fire with nostalgia. We enjoy the aroma and find the flickering light of a cozy hearth reminding us of things past. Wood has a low ash content. The little ash that remains after burning is useful in home gardening as a fertilizer and soil conditioner.

WHICH WOODS ARE BEST?

Each wood species offers something different in aroma or heat value. You should consider your needs and desires before building your fire.

Softwoods, like pine, spruce and fir are easy to ignite because they contain a lot of resin. However, a fire built entirely of softwoods burns out quickly. You also must add wood more often. While a softwood fire is not too desirable for a long evening, it's fine in the morning when you want quick warmth or late in the evening when you want a fire that will burn out before you go to bed.

On occasion when a longer fire is desired, it's best to combine softwoods with the heavier hardwoods such as ash, beech, birch, maple, oak and hickory. Hardwood burns slower, with shorter flames, and produce steady, glowing coals.

For the most pleasing aroma, burn the wood of fruit trees such as apple and cherry, or nut trees such as beech, hickory and pecan. This wood is generally more expensive, but a little combined with other wood goes a long way. Start your fire with a mixture of softwood and hardwood. Add some fruit or nut wood for nostalgic aroma. Since most woods will not burn well when freshly cut, the wood you purchase should be reasonably dry. Purchase logs that will fit when laid across your grate. Ask that the larger, heavier logs be split. Kindling should be short, easily split lengths of softwood, lumber yard or mill scraps, or twigs and branches gathered from your yard.

HOW TO BUILD A BETTER FIRE

The first three fires should be of moderate size. This lets the fireplace adjust to the heat and the bricks to cure.

First, make sure your room is well ventilated, your damper open and the flue is unobstructed. Then make sure your wood is dry and seasoned. Unseasoned wood burns poorly. If you use unseasoned wood with poor ventilation or an obstructed chimney, smoking could occur.

If your fireplace is equipped with an outside combustion air assembly, open the combustion air inlet by pushing upward on the lever located above the firebrick on the left side of the firebox.

WARNING

Never use gasoline, gasoline-type lantern fuel, kerosene, charcoal lighter fluid, or similar liquids to start or "freshen up" a fire in this fireplace. Keep all such liquids well away from the fireplace while it is in use. Use of this fuel can cause a serious explosion.

Prepare your fire by placing two logs on the iron grate or fire basket, and laying the tinder between them. Tinder may be dry scrap paper, twigs or bark. On top place a small handful of twigs or split softwood kindling. Place more dry logs over this base. Keep logs close together, as narrow air spaces between them promote better drafts. Heat reflected between adjacent surfaces aids in raising and maintaining combustion temperatures.

You'll need a minimum of three logs, preferably four, to make a good fire. Add kindling and new logs as needed to rekindle a dying fire. New logs should be added at the rear grate after raking the coals toward the front. **Note: Do Not Overfire the Fireplace.** Overfire conditions happen when you use large amounts of kindling, building scraps or other improper fuels.

Ashes are important because they form a bed of glowing coals. Let ashes build up to 1" to 2" on the bottom of the grate. Excess ashes can be used to check a flaming fire or to "bank" your fire. Cover the logs with ashes. A "banked" fire will hold glowing coals for 8-10 hours, thereby saving a fire for later use.

WOOD VS. FOSSIL FUELS

Compared to fossil fuels, a full cord of dry hickory weighs about two tons and is approximately equal in heating value to a ton of hard coal. On a per pound basis, heavy hardwoods have about half the heating value of coal. The table below shows the relative densities and heat values of a variety of dry woods. Varieties at the top of the list (Dogwood) burn longer and those near the bottom (White Pine) ignite and burn quicker. A combination of both light and heavy wood is desired.

| SPECIES VALUE | DENSITY | HEAT |
|---------------|---------|---------|
| Dogwood | .70-.79 | 100-107 |
| Hickory | .70-.74 | 100 |
| Oak | .60-.73 | 86-99 |
| Black Locust | .69-.70 | 95-98 |
| Beech | .64-.66 | 89-91 |
| Hard Maple | .58-.65 | 83-88 |
| Birch | .55-.64 | 79-86 |
| Apple | .58-.62 | 83-84 |
| Ash | .57-.61 | 81-82 |
| Southern Pine | .51-.60 | 73-81 |
| Elm | .50-.59 | 71-80 |
| Cherry | .50-.52 | 70 |
| Douglas Fir | .45-.51 | 64-69 |
| Spruce | .41-.44 | 59 |
| Redwood | .33-.40 | 47-54 |
| White Pine | .35-.37 | 50 |

A FEW WORDS OF CAUTION

Do not burn plastics, poison ivy twigs and stems and chemically treated woods such as discarded poles and railroad ties in your fireplace. These create air pollution and can cause extreme irritation for some people.

Use hemlock, spruce, juniper and other resinous woods with caution. They contain moisture pockets which, upon heating, “pop” with considerable vigor.

Always use a fire screen. Always “bank” a fire (or at least push all unburned fuel to the rear of the grate) before leaving a fire unattended. Do not use this fireplace as an incinerator.

The termination of the chimney above the roof is exposed to wind, cold, and pressure changes. These and other environmental conditions may make it hard to get a sufficient chimney draft at times. At other times the draft may be sufficiently disrupted and cause smoke to spill from the fireplace opening. If problems with chimney draft occur, help start chimney draft before you build a fire by holding a piece of burning paper near the flue opening at the top of the firebox to preheat the chimney. If smoke spills from the fireplace opening after the fire is burning, open a window on the up wind side of the house that is far enough away from the fireplace that the wind will not blow across the fireplace opening. Push burning wood as near the back of the fireplace as possible. If your fireplace has glass doors, close them.

***IMPORTANT:** Do not leave children or physically or mentally handicapped, or senile persons alone with a burning fireplace.*

MAINTENANCE

FUEL STORAGE

Wood can be dried sufficiently for burning within a few weeks if protected from rain in a low humidity area. It is better to cut wood and allow it to dry for a year. In all cases, the wood should be stacked so that both ends of the sticks are exposed to the air and protected from rain. The drier the wood, the more usable heat produced by the fire and less likely rapid accumulation of soot and creosote within the chimney is to occur. See *Chimney Maintenance* for information on the hazards of soot and creosote accumulation. Small quantities of wood required for fire tending must be kept at least 30" from the fireplace.

DISPOSAL OF ASHES

Ashes should be placed in a metal container with a tight fitting lid. The closed container of ashes should be placed on a noncombustible floor or on the ground well away from all combustible materials until they are finally disposed of. If the ashes are buried or locally dispersed, they should be kept in the closed container until all cinder has thoroughly cooled. Ashes should never be placed in a container with combustible materials.

CHIMNEY MAINTENANCE

Creosote, Formation and Need for Removal

When wood is burned slowly, it produces tar and other organic vapors which combine with expelled moisture to form creosote. The creosote vapors condense in the relatively cool chimney flue of a slow-burning fire. As a result, creosote residue accumulates on the flue lining. When ignited, this creosote makes an extremely hot fire.

Note: *The chimney should be inspected at least twice a year during the heating season to determine if a creosote buildup has occurred. If creosote has accumulated it should be removed to reduce the risk of a chimney fire.*

The chimney cap can be removed for inspection, maintenance and cleaning by removing three screws from the support legs and lifting upward.

When the fireplace is new, inspect the chimney often and clean the chimney any time creosote is seen on the flue walls. Once you see a pattern of how often creosote is accumulating, you can determine how often the chimney should be inspected.

Also changes in the outside environmental conditions such as temperature and humidity or changes in the operation of the fireplace can lead to rapid buildup of soot and/or creosote.

Have a qualified and reputable chimney sweep clean the chimney or remove creosote or soot with brushes on wooden or fiberglass poles. **Note: *Do not use metal pipes, chains, wires, etc., to clean the chimney. They can scratch the surface of the stainless steel flue. This will shorten the life of the flue and provide a rough surface for soot particles to attach to.***

Be sure to cover nearby furnishing and arrange some method of catching soot and creosote particles that may fall during the chimney cleaning process. If glass doors are installed on the fireplace, they should be closed. Extra caution must be used to avoid damage to the flue damper during the cleaning process.

In addition to checking and cleaning the chimney on a regular basis, be sure to inspect the chimney before starting a fire at the beginning of each heating season. Make sure the chimney is clear from any accumulation of soot, creosote or any other debris. Make sure all joints are intact.

Monessen Hearth Systems does not recommend chemical cleaners because some may contain elements that corrode the metal parts of the chimney or fireplace.

FIREPLACE MAINTENANCE

At the end of each heating season or when the fireplace will not be in use for an extended time, the ashes should be removed and the hearth area should be swept clean. The slow absorption of moisture into the ashes over a long period of time could corrode metal fireplace parts.

At the beginning of each heating season, always operate the flue damper and make sure it has not become stuck from soot, creosote, etc.

Keep the lower and upper grille panels clean and free from dirt and lint accumulation at all times to get the maximum efficiency from your fireplace.

As you use the fireplace, expansion and contraction will cause minor cracking of the hearth, back and side refractory materials. This is normal and unavoidable. If the cracks become large enough or parts dislodge and metal behind the refractory is exposed, the refractory panels should be replaced with new panels. Obtain these panels Monessen Hearth Systems fireplace dealer.

GLASS DOOR MAINTENANCE

For glass door maintenance, see instructions provided with the glass doors.

CHECKLIST OF DO'S AND DON'Ts**DO'S**

1. Do check with local building officials to be sure the installation of the fireplace complies with all building codes and requirements. Obtain required building permits. Do plan your installation with safety as your primary consideration.
2. Do use only the prescribed material and parts for the installation of the fireplace.
3. Do insulate the exterior walls surrounding the fireplace to prevent excessive heat loss from the fireplace.
4. Do trim the face of the fireplace only with non-combustible materials.
5. Do attach the non-combustible face trim material firmly to the face of the fireplace.
6. Do block in or fasten the fireplace to prevent the possibility of the fireplace shifting out of position.
7. Do connect the air circulation blower to a properly grounded and fused electrical circuit.
8. Do enclose the chimney where it passes through living spaces or spaces accessible for storage purposes to prevent contact with and possible damage to the chimney.
9. Do install firestop spacers at each ceiling level when the chimney is installed in a multistory building.
10. Do install the proper chimney cap or chimney housing on the chimney to prevent rain and debris from entering the chimney.
11. Do keep all flammable liquids, gases and pressurized containers away from the fireplace.
12. Do check the fireplace for proper adjustment and operation before leaving it unattended for long periods of time.
13. Do inspect and clean the fireplace chimney regularly.
14. Do keep the fire screens closed when the fireplace is left unattended to minimize the danger of sparks popping out of the fireplace.
15. Do use the grate furnished with and for this fireplace.
16. Do start a fire only with paper, kindling or solid composition fire starters specifically designed for starting a fire. The use of liquid fire starter can cause an explosion within the fireplace.
17. Do place all ashes in a metal container with a tight fitting lid and place them on a noncombustible surface well away from other combustible materials until they have completely cooled.
18. Do store your fuel supply at a distance equal to or greater than the spacing recommended for combustible materials from the fireplace.
19. Do build fires of moderate intensity in the fireplace for the first three fires to allow materials to adjust and cure before being subjected to the intense heat of a large fire.

WARNING

If not installed, operated and maintained in accordance with the manufacturers instructions, this product could expose you to substances in fuel or from fuel combustion which can cause death or serious illness and which are known to the state of California to cause cancer, birth defects or other reproductive harm. Also, operation, installation and servicing of this product could expose you to airborne particles of glass wool fibers known to the state of California to cause cancer through inhalation."

MAINTENANCE AND SAFETY

DON'Ts

1. Don't allow other installations or operation considerations to take priority over safety considerations.
2. Don't attempt to use the fireplace until the installation is complete.
3. Don't use unlisted parts and accessories with the fireplace except for special flashings fabricated locally.
4. Don't use damaged parts or accessories with this fireplace.
5. Don't install the fireplace in an exposed or uninsulated area.
6. Don't install the fireplace over carpeting.
7. Don't install the fireplace on a poorly constructed base or fail to fasten down or attach the fireplace to prevent it from shifting out of position.
8. Don't create or allow a crack to develop between the metal face of the fireplace and noncombustible trim.
9. Don't use power blowers or air circulation systems with this fireplace that are not specifically recommended by Monessen Hearth Systems .
10. Don't connect accessory air circulation blowers to improperly fused or ungrounded electrical circuits.
11. Don't install the fireplace where flammable or explosive liquids or vapors are likely to be present.
12. Don't neglect all the considerations mentioned in this manual concerning clearances to combustibles, spacing from obstructions and proper chimney height when selecting the location and installing the chimney.
13. Don't allow insulating materials to contact the chimney.
14. Don't neglect to apply caulking or mastic to the required joints of the flashing and between the flashing roof.
15. Don't dry clothing or other articles near the fireplace.
16. Don't store or place flammable liquids, gases or pressurized containers near the fireplace.
17. Don't neglect to instruct all responsible persons in the proper and safe operation of the fireplace.
18. Don't fail to instruct all persons, especially children and elderly persons, concerning the hazards of improper operation and unauthorized tampering with the fireplace.
19. Don't use this fireplace to burn paper, cardboard, or other debris.
20. Don't neglect to inspect and clean the chimney regularly.
21. Don't operate the fireplace with the glass fire screen doors partially open. The doors should always be fully open or fully closed.
22. Don't use gasoline, kerosene, engine oil, charcoal lighter fluid or other flammable liquids to start or intensify a fire. Using these and similar materials can cause an explosion within the fireplace.
23. Don't store fuel supply closer to the fireplace than the minimum spacing required for combustible materials.
24. Don't subject the fireplace to the intense heat of a large fire the first three times the fireplace is used, but build moderate fires to allow the materials to cure and adjust.
25. Don't clean the chimney with metallic devices or chemical cleaners.
26. Don't use the fireplace or chimney for venting wood or coal burning heaters or inserts unless approved in writing by Monessen Hearth Systems .
27. Don't put combustibles within 24 inches of the fireplace opening

REPLACEMENT PARTS ARE AVAILABLE THROUGH YOUR RETAILER

| Item | Description | QTY | 400 Unit | 500 Unit |
|------|---------------------------|-----|----------|----------|
| 1 | Weldment Air Door Rod | 1 | 031867 | 031867 |
| 2 | Firescreen Panels | 2 | 61D0001 | 61D0003 |
| 3 | Back Firebrick Assembly | 1 | 61D0102 | 61D0107 |
| 4 | Side Firebrick Assembly | 2 | 61D0101 | 61D0101 |
| 5 | Painted Grate Assembly | 1 | 61D0020 | 61D0022 |
| 6 | Bottom Firebrick Assembly | 1 | 61D0100 | 61D0106 |

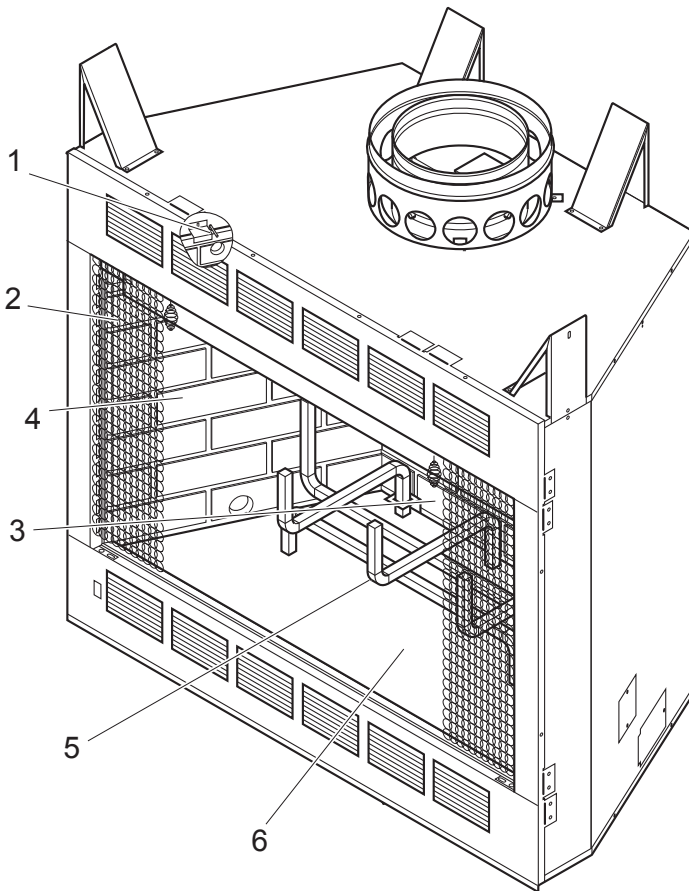

Circulating Models:

**BWBC400A BWBC400IA BWBC500A
BWBC500IA**

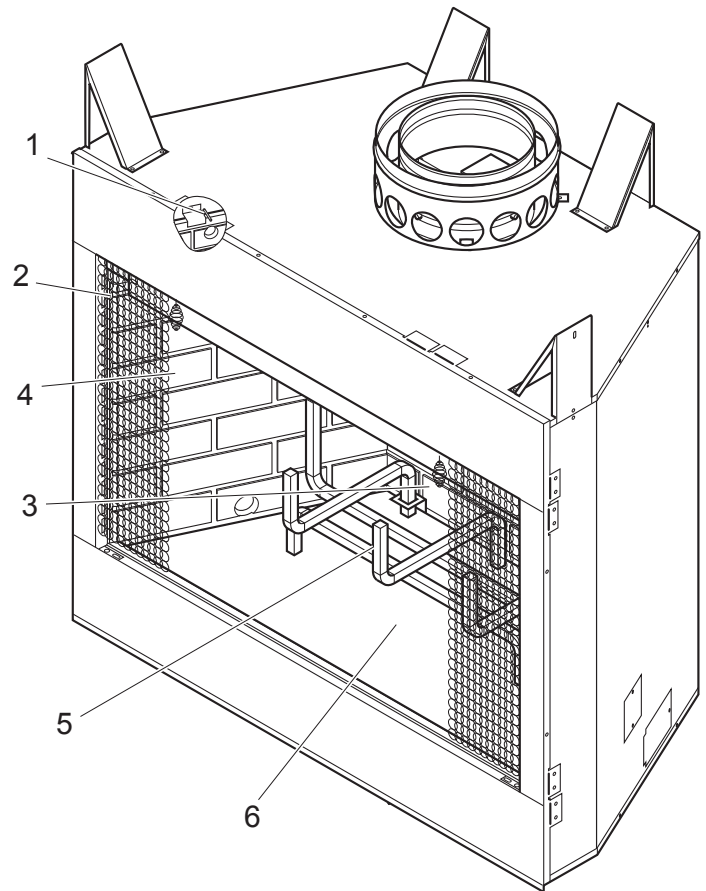

Radiant Models:

**BWB400A BWB400IA BWB500A
BWB500IA**

WARNING

Failure to position the parts in accordance with these diagrams or failure to use only parts specifically approved with this appliance may result in property damage or personal injury.

REPLACEMENT PARTS ARE AVAILABLE THROUGH YOUR RETAILER

REPLACEMENT PARTS

| Item | Part No. | Description |
|------|----------|---|
| 1 | GD36PBA | Optional 36" polished brass bifold glass door kit; polished brass finish frame; tempered clear glass |
| 1 | GD36BA | Optional 36" black bifold glass door kit. black finish frame; tempered clear glass |
| 1 | GD36SSA | Optional 36" stainless bifold glass door kit; stainless finish frame; tempered clear glass |
| 1 | GD42PBA | Optional 42" polished brass bifold glass door kit; polished brass finish frame; tempered clear glass |
| 1 | GD42BA | Optional 42" black bifold glass door kit; black finish fram; tempered clear glass |
| 1 | GD42SSA | Optional 42" stainless bifold glass door kit; stainless finish frame; tempered glass is clear. |
| 2 | SCS | Chimney support (Required when chimney height exceeds 30') |
| 3 | SE30 | Elbow offset/return package containing two 8" diameter 30° elbows |
| 4 | 612 | 0 to 6/12 variable pitch roof flashing; one 612 flashing required with SC round chimney cap on 0 to 6/12 pitch roof |
| 4 | 1212 | 6/12 to 12/12 variable pitch roof flashing. One 1212 flashing required with SC round chimney cap on 6/12 to 12/12 pitch roof |
| 5 | SC | Round chimney cap for contemporary installation; includes storm collar |
| 6 | SF | 14 ¹ / ₂ " firestop spacer. One required at each ceiling or floor level |
| 7 | H1652 | 16"x52" hearth extension for protecting floor against sparks and radiant heat |
| 7 | H2066 | 20"x66" hearth extension for protecting floor against sparks and radiant heat |
| 8 | AK4 | 4" diameter outside combustion air kit; allows air from outside to enter fireplace (For residential homes) |
| 8 | AK6 | 6" diameter outside combustion air kit; allows air from outside to enter fireplace (For manufactured homes) |
| 9 | FP4U | 4" diameter x 8' long flexible uninsulated combustion air duct (Use with AK4 kit) |
| 9 | FP6U | 6" diameter x 8' long flexible uninsulated combustion air duct (Use with AK6 kit) |
| 10 | 403 | 4" duct connector for splicing FP4U ducts; includes one connector and two clamps |
| 10 | 603 | 6" duct connector for splicing FP6U ducts; includes one connector and two clamps |
| 11 | FA2A | Optional fan kit, with switch; FA2 fan installs under firebox bottom; removal of brick is required; install JB1 junction box at the time the fireplace is installed if the FA2A Fan is to be installed at any time. |
| 12 | R3672 | 36"x72" flat chase flashing with single flue hole |
| 12 | R4884 | 48"x84" flat chase flashing with single flue hole |
| 13 | CF8 | Terra Cotta masonry-look termination chimney cap for chase installation; use with VFK flashing kit |
| 14 | S48 | 48" long x 8" diameter chimney flue section |
| 14 | S36 | 36" long x 8" diameter chimney flue section |
| 14 | S18 | 18" long x 8" diameter chimney flue section |
| 14 | S12 | 12" long x 8" diameter chimney flue section |

REPLACEMENT PARTS

REPLACEMENT PARTS ARE AVAILABLE THROUGH YOUR RETAILER

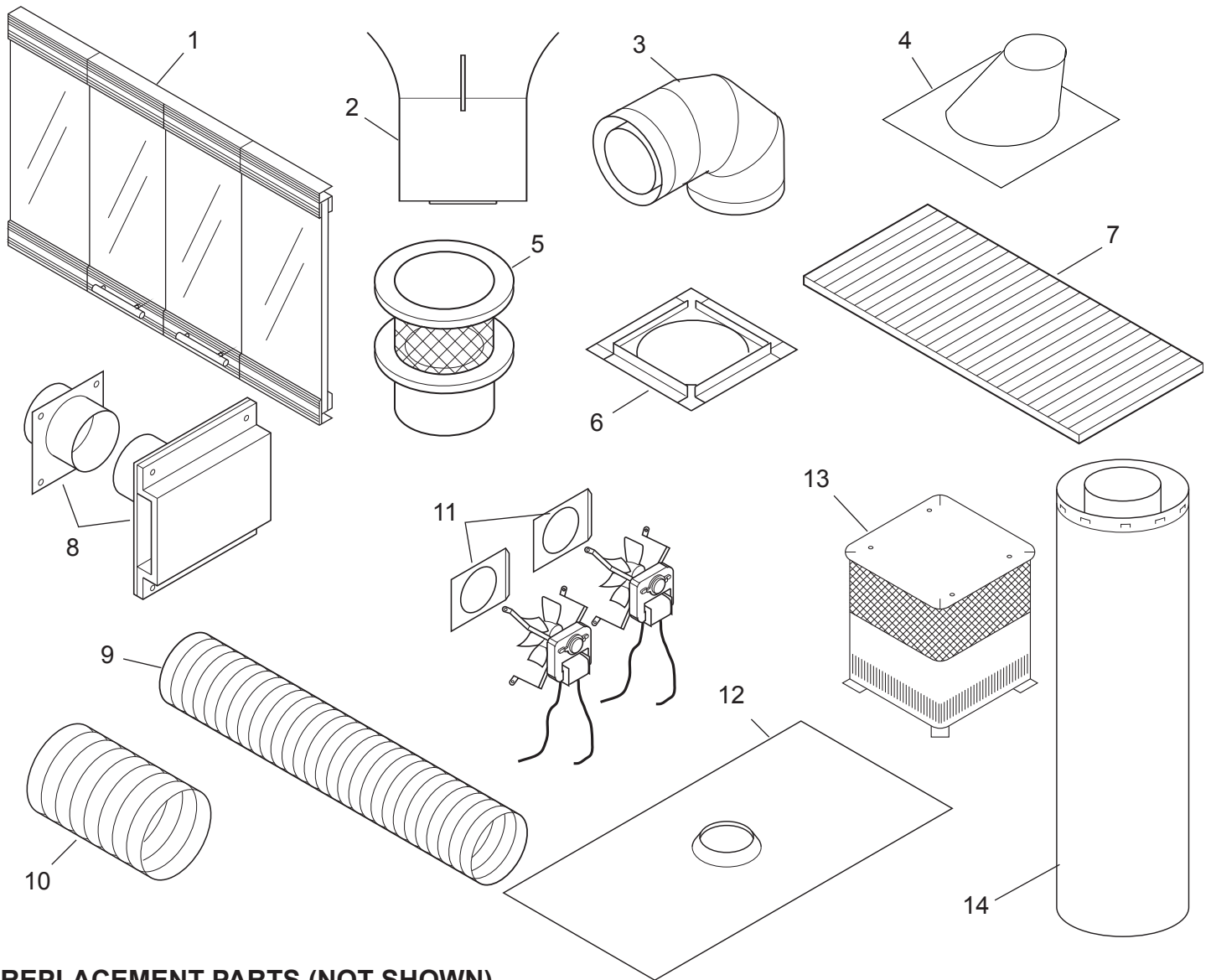

REPLACEMENT PARTS (NOT SHOWN)

| Item | Description |
|-------|---|
| SCL | Round chimney cap with telescoping pipe and storm collar. (For chase installation) |
| SQ8 | Square termination chimney cap (18 ¹ / ₂ " x 18 ¹ / ₂ ") for chase installation (Use with VFK flashing kit) |
| SF30 | Firestop spacer for 30° chimney incline through ceiling or floor |
| S8 | 8" diameter double-wall telescope pipe for use with LFSQT chimney cap |
| LFSQT | Square shroud termination chimney cap for chase installation; use with S8 telescope pipe and VFK flashing kit (Minimum chase top dimensions: 26"x26") |
| SPC | Pyramid shroud termination chimney cap for chase installation |
| H36 | Hood for heat deflection; may be installed on fireplace in residential type home to reduce the recommended clearance to a combustible mantel; do not use with glass doors. |
| VFK | Vent flashing kit consisting of adjustable radiation shield with spacer brackets and fasteners (For venting a field-constructed flashing assembly on a combustible chase top) |

NOTES

ATTENTION APPLIANCE INSTALLER

**PLEASE RETURN THESE
OPERATING AND
INSTALLATION
INSTRUCTIONS
TO THE CONSUMER!**

LIMITED WARRANTY
FACTORY-BUILT FIREPLACE AND COMPONENTS
(EXCEPT BLOWERS)

WHAT IS COVERED AND FOR HOW LONG

- **Five-Year Coverage:** For five years from the date this fireplace and components are first purchased for use, Monessen Hearth Systems will, at its option, repair or replace any defective part of this fireplace or components, or refund to you a sum not to exceed the factory retail price in effect at the time of purchase.
- **Ten-Year Coverage:** From the sixth through the tenth year following the date this fireplace or accessory is first purchased for use, Monessen Hearth Systems will make available to you, at our factory, a free replacement for any defective part in this fireplace or accessory.
- **Twenty-Five-Year Availability of Replacement Parts:** From the eleventh through the twenty-fifth year following the date this fireplace or accessory is first purchased for use, Monessen Hearth Systems will make available at our factory replacement parts for this fireplace or accessory, which you may purchase for the list price current at the time your purchase order is received.

WHAT IS NOT COVERED

This limited warranty does not cover:

- Transportation or shipping cost.
- The cost of a service call to diagnose trouble.
- Painted surfaces.
- Damage or defect caused by improper installation, accident, misuse, abuse or alteration.
- Poor ventilation of smoke or gases caused by air-conditioning and heating systems, exhaust fans, or pressure differentials produced by wind.
- Broken glass components
- Cracks in ceramic and castable parts that do not affect safe operation.
- We do not warrant this fireplace to be in compliance with your local building code. Building codes vary greatly throughout the country, and you should determine whether your local building code contains restrictions on the use of this fireplace before you purchase it.
- Blowers or fans, which are warranted separately.
- Heat loss due to the passage of heat or air through or around the fireplace.

Also, under our five year coverage, we do not pay the cost of removal and replacement of any portion of the structure in which the fireplace is situated, made necessary by the repair, removal or re-installation of the fireplace.

And under our twenty-five year warranty of availability of replacement parts, we only promise to maintain a supply of replacement parts at our factory for you to purchase.

LIMITATIONS AND EXCLUSIONS

1. No one has authority to add to or vary this limited warranty, or to create for Monessen Hearth Systems any other obligation of liability in connection with this fireplace and accessory.
2. Monessen Hearth Systems shall not be liable for incidental, consequential, special or contingent damages you might suffer as a result of its breach of this written warranty or any implied warranty. Some states do not allow the exclusion of limitation of incidental or consequential damages, so the above limitations may not apply to you.
3. This warranty applies only to the original purchaser of the fireplace or to the original owner of the dwelling when the fireplace is installed in a new dwelling and may not be transferred.
5. This warranty applies only to a fireplace sold and used in the United States.

For information about this warranty, contact:

Technical Services
Monessen Hearth Systems
149 Cleveland Drive
Paris, Kentucky 40361