

This Owner's Manual is provided and hosted by [Appliance Factory Parts](#).

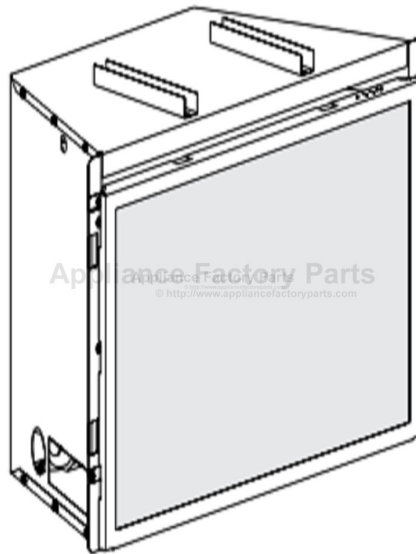

EMPIRE VFLC20IN72 Owner's Manual

[Shop genuine replacement parts for EMPIRE
VFLC20IN72](#)



[Find Your EMPIRE Other Parts - Select From 58 Models](#)

----- Manual continues below -----

INSTALLATION INSTRUCTIONS AND OWNER'S MANUAL

Loft Vent-Free Fireplace Insert

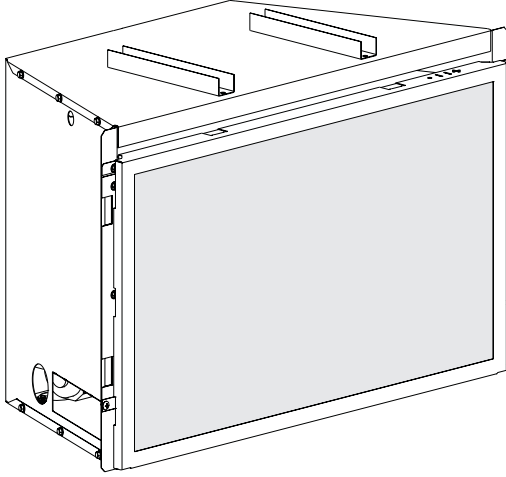

Shown without required front.

INSTALLER:

Leave this manual with the appliance.

CONSUMER:

Retain this manual for future reference.

⚠ WARNING

FIRE OR EXPLOSION HAZARD

Failure to follow safety warnings exactly could result in serious injury, death or property damage.

- Do not store or use gasoline or other flammable vapors and liquids in the vicinity of this or any other appliance.
- **WHAT TO DO IF YOU SMELL GAS**
 - Do not try to light any appliance.
 - Do not touch any electrical switch; do not use any phone in your building.
 - Leave the building immediately.
 - Immediately call your gas supplier from a neighbor's phone. Follow the gas supplier's instructions.
 - If you cannot reach your gas supplier, call the fire department.
- Installation and service must be performed by a qualified installer, service agency or the gas supplier.

UNVENTED GAS FIREPLACE MODELS:

VFLC10IN32(N,P)-1

VFLC20IN32(N,P)-1

VFLC20IN72(N,P)-1

VFLC28IN32(N,P)-1

VFLC28IN72(N,P)-1



⚠ WARNING

If not installed, operated and maintained in accordance with the manufacturer's instructions, this product could expose you to substances in fuel or from fuel combustion which can cause death or serious illness.

⚠ WARNING

"FIRE, EXPLOSION, AND ASPHYXIATION HAZARD
Improper adjustment, alteration, service, maintenance, or installation of this heater or its controls can cause death or serious injury. Read and follow instructions and precautions in User's Information Manual provided with this heater."

This is an unvented gas-fired heater. It uses air (oxygen) from the room in which it is installed. Provisions for adequate combustion and ventilation air must be provided. Refer to pages 16 and 17.

WATER VAPOR: A BY-PRODUCT OF UNVENTED ROOM HEATERS
Water vapor is a by-product of gas combustion. An unvented room heater produces approximately one (1) ounce (30ml) of water for every 1,000 BTU's (.3KW's) of gas input per hour. Refer to page 16.

This appliance may be installed in an aftermarket, permanently located, manufactured (mobile) home, where not prohibited by local codes. This appliance is only for use with the type of gas indicated on the rating plate. This appliance is not convertible for use with other gases.



We suggest that our gas hearth products be installed and serviced by professionals who are certified in the U.S. by the National Fireplace Institute® (NFI) as NFI Gas Specialists.

TABLE OF CONTENTS

SECTION	PAGE
CARTON CONTENTS AND HARDWARE PACK.....	3
BEFORE YOU START.....	4
IMPORTANT SAFETY INFORMATION.....	5-6
SAFETY INFORMATION FOR USERS OF PROPANE GAS.....	6-7
IMPORTANT INSTALLATION GUIDELINES.....	7
INTRODUCTION.....	8
SPECIFICATIONS.....	9
INSTALLATION IN A FIREPLACE.....	10
FIREPLACE INSERT DIMENSIONS.....	11
BUILT-IN FIREPLACE INSTALLATION.....	12
VFLC(10,20)IN FIREPLACE SURROUND DIMENSIONS.....	13
VFLC28IN FIREPLACE SURROUND DIMENSIONS.....	14
ALTERNATE ON/OFF SYSTEM INSTALLATION.....	15
WATER VAPOR: A BY-PRODUCT OF UNVENTED ROOM HEATERS.....	16
PROVISIONS FOR ADEQUATE COMBUSTION & VENTILATION AIR.....	16-17
GAS SUPPLY.....	18-19
(COMBUSTIBLE) CLEARANCES.....	19
COMBUSTIBLE MATERIALS.....	20
MILLIVOLT ALTERNATE ON/OFF SWITCH INSTALLATION.....	21
DECORATIVE ACCESSORY INSTALLATION.....	22
10,000 BTU MILLIVOLT CONTROL VALVE LIGHTING INSTRUCTIONS.....	23
MILLIVOLT CONTROL VALVE LIGHTING INSTRUCTIONS.....	24
MILLIVOLT CONTROL VALVE WIRING.....	25
PILOT FLAME CHARACTERISTICS.....	26
TROUBLESHOOTING SYMPTONS, POSSIBLE CAUSES AND CORRECTIONS.....	27
INTERMITTENT PILOT LIGHTING INSTRUCTIONS.....	28
OPERATION INSTRUCTIONS/FLAME APPEARANCE.....	29
PILOT FLAME CHARACTERISTICS.....	30
IPI ELECTRONIC SYSTEM OPERATING INSTRUCTIONS.....	31
IPI ELECTRONIC SYSTEM WIRING DIAGRAM.....	32
INTERMITTENT CONTROL SYSTEM TROUBLSHOOTING.....	33-37
VFLC(20,28)IN PARTS LIST.....	38
VFLC(20,28)IN PARTS VIEW.....	39
MASTER PARTS DISTRIBUTOR LIST.....	40
HOW TO ORDER REPAIR PARTS.....	40
WARRANTY.....	41
APPLIANCE SERVICE HISTORY.....	42-43

CARTON CONTENTS & HARDWARE PACK

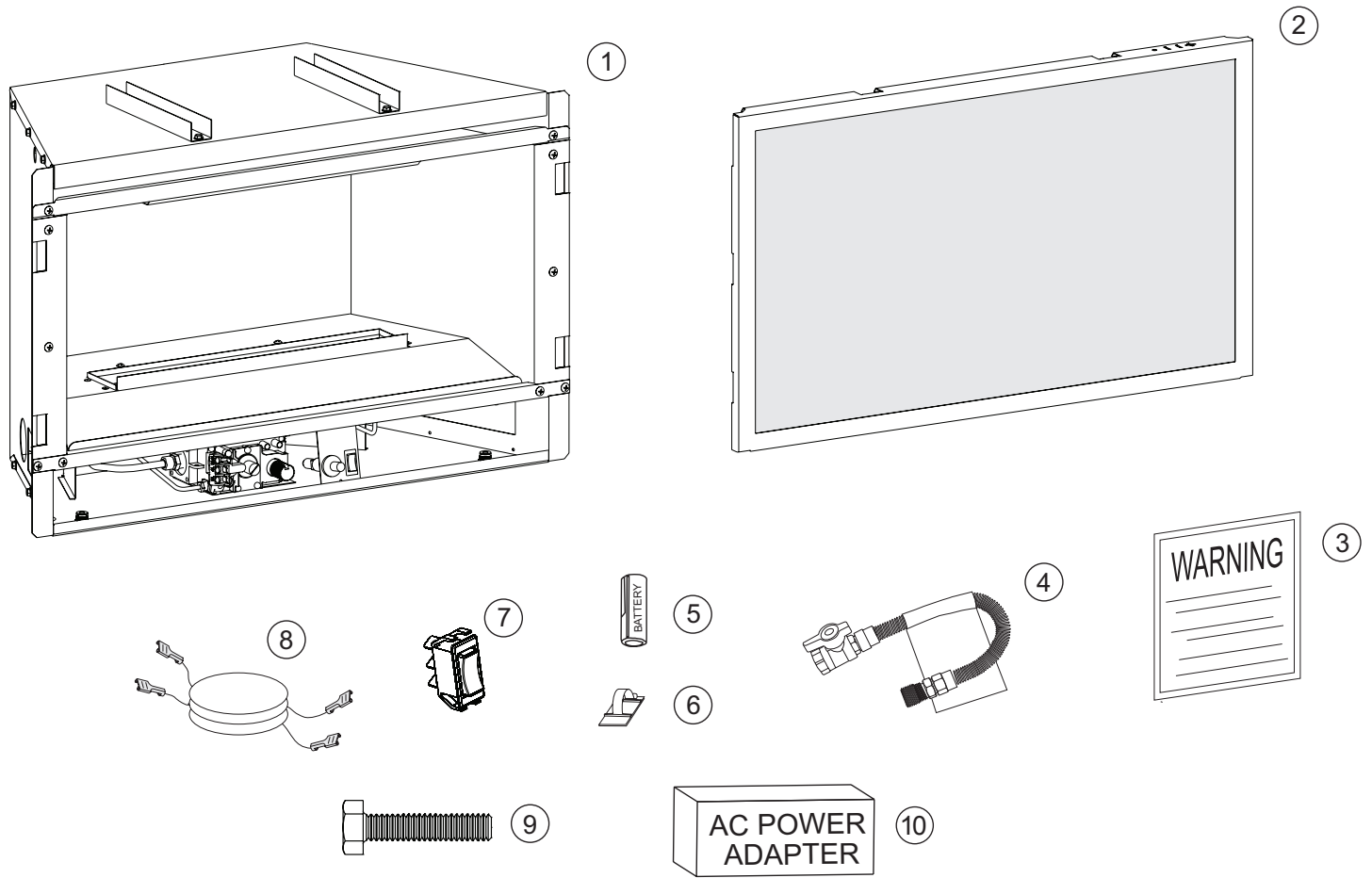

Index Number	Description	Quantity Supplied		Location
		MV	IP	
1	Fireplace Insert	1	1	In carton
2	Barrier Screen Assembly	1	1	Front of Insert
3	Warning Label Plate	1	1	In envelope
4	Flex Line with Shut-off	1	1	Attached to the gas valve
5	AA Batteries	0	4	In envelope
6	Wire Retainer Clips	3	3	In envelope
7	ON/OFF Switch	1	1	In envelope
8	Extension Wire Harness	1	1	In envelope
9	5/16-18 Hex Head bolt, 2-1/2 inches long	4	4	In envelope
10	AC Power Adapter	0	1	In envelope

BEFORE YOU START

WARNING

Read and follow these safety precautions prior to operating this appliance. Failure to follow these precautions may result in death, injury, or property damage.

Samples and Definitions:

DANGER

Indicates a hazardous situation which, if not avoided, will result in death or serious injury.

WARNING

Indicates a hazardous situation which, if not avoided, could result in death or serious injury.

CAUTION

Indicates a hazardous situation which, if not avoided, could result in minor or moderate injury.

NOTICE: Addresses practices not related to personal injury.

Attention! If the fireplace insert is installed into a modified wood-burning, factory-built fireplace, the fireplace cannot be returned to a wood-burning fireplace. See page 10 for additional details regarding the allowed modifications to a factory-built fireplace.

Read all instructions before starting installation and follow them carefully to insure safety. Failure to follow the instructions will void the warranty and may cause a fire hazard.

The warranty will be voided by, and the warranter disclaims any responsibility for the following actions:

- Installation of any damaged fireplace insert.
- Modification of the fireplace insert.
- Installation other than as instructed by Empire Comfort Systems Inc.
- Improper positioning of logs, barrier screen, or decorative accessories.
- Installation and/or use of any component part not manufactured or approved by the manufacturer.

All correspondence should refer to complete Model Number, Serial Number and type of gas. Fill out the Homeowner Reference Section on page 46.

Unpacking the fireplace insert:

1. Cut binding straps.
2. Remove the top carton.
3. Carefully remove the carton contents.
4. Use the Carton Contents and Hardware Pack lists on page 3 to verify all components are present.
5. Verify that the fireplace insert and components have not been damaged during shipping.
6. **To remove the Barrier Screen Assembly:**
 - a. Lift screen frame straight up about 1/2".
 - b. Pull the bottom outward just enough to release the bottom retainer bracket from the firebox bottom flange.
 - c. Pull the top of the frame forward about 1/2", then lower barrier to remove from the insert.
7. Set fireplace insert in a location near its final installation location.

Preparation

This fireplace insert and its components are safe when installed in accordance with this Installation Manual. Report any parts damaged in shipment to your dealer. Do not install the fireplace insert with damaged, incomplete or substitute parts.

Installation Considerations - Fireplace Installation Guidelines

Determine where to install the fireplace insert. The fireplace insert can be mounted on any of these surfaces:

1. A flat hard combustible or non-combustible surface
2. A raised platform of combustible or non-combustible material
3. Or, install in wood burning fireplace

If the fireplace is installed directly on carpeting, tile or other combustible material other than wood or flooring, it must be installed on a metal or wood panel extending the full width and depth of the fireplace insert.

This fireplace insert is designed to be installed in a zero-clearance enclosure. This means combustible material such as framing lumber can come in contact with the top and side standoff spacers, and be secured to combustible framing.

This fireplace insert requires an easily accessible gas shut-off valve be installed in the gas supply line prior to its entry to the fireplace.

Determine the following before installation:

- Any desired accessories
- Gas supply piping
- Electrical connections
- Electrical supply requirements for blower (120V, 60Hz, 1Amp) (Right entrance)

A selection of a shut-off valve containing a flange and key is recommended.

IMPORTANT SAFETY INFORMATION

⚠ DANGER: Indicates a hazardous situation which, if not avoided, will result in death or serious injury.

⚠ WARNING: Indicates a hazardous situation which, if not avoided, could result in death or serious injury.

⚠ CAUTION: Indicates a hazardous situation which, if not avoided, could result in minor or moderate injury.

NOTICE: Addresses practices not related to personal injury.

- An unvented room heater having an input rating of more than 6,000 Btu per hour shall not be installed in a bathroom
- An unvented room heater having an input rating of more than 10,000 Btu per hour shall not be installed in a bedroom or bathroom.
- Due to high temperatures, the appliance should be located out of traffic and away from furniture and draperies.
- Children and adults should be alerted to the hazard of high surface temperature and should stay away to avoid burns or clothing ignition.
- Young children should be carefully supervised when they are in the same room with the appliance.
- Do not place clothing or other flammable material on or near the appliance.
- Avoid the use of scented air fresheners (plug in type air fresheners, etc.) while the burner is in operation. Air fresheners produce a residue in the air similar to candles and may produce a soot like substance.
- Avoid the use of scented or decorative candles while the burner is in operation. Candles produce a residue in the air that creates a soot like substance. Burning candles while the log set is operating magnifies the problem. It should be noted that candles, in general, produce soot. The amount of time burned and the quantity of candles burned will determine the amount of soot produced and deposited.
- Installation and repair should be done by a **QUALIFIED SERVICE PERSON**. This appliance should be inspected before use and at least annually by a professional service person. More frequent cleaning may be required due to excessive lint from carpeting, bedding materials, etc. It is imperative that control compartments, burners and circulating air passageways of the appliance be kept clean.
- **DO NOT** use this room heater if any part has been under water. Immediately call a qualified service technician to inspect the room heater and to replace any part of the control system and any gas control which has been under water.
- You must operate insert with decorative front installed.
- Do not place debris, logs or other articles in fireplace insert during operation.
- During manufacturing, fabricating and shipping, various components of this appliance are treated with certain oils, films or bonding agents. These bonding agents are not harmful but may produce annoying smoke and smells as they are burned off during initial operation of the appliance. This is a normal temporary occurrence. A window should be opened during the initial bake out period.
- **⚠ WARNING:** Do not allow fans to blow directly into the fireplace. Avoid any drafts that alter burner flame patterns.
- **⚠ WARNING:** Do not use a blower insert, heat exchanger insert or other accessory not approved for use with this heater.
- **⚠ WARNING!** This fireplace needs fresh air for ventilation to run properly. This fireplace has an ODS (oxygen depletion sensor) which will shut down the heater if adequate fresh air is not available. See troubleshooting section in the instructions.
- **⚠ WARNING:** Do not place large rocks or embers (rock wool) in fireplace insert.

- **⚠ WARNING:** **DO NOT** operate this appliance unless all components including burners, and controls are in good working condition. Replacement components are available through your local dealer as indicated in the How to Order Repair Parts section of the appliance manual.
- Keep appliance area clear and free from combustible materials, gasoline and other flammable vapors and liquids.
- **⚠ WARNING:** Failure to keep the primary air opening(s) of the burner(s) clean may result in sooting and property damage.

⚠ WARNING

When used without adequate combustion and ventilation air, heater may give off **CARBON MONOXIDE**, an odorless, poisonous gas.

Do not install heater until all necessary provisions are made for combustion and ventilation air. Consult the written instructions provided with the heater for information concerning combustion and ventilation air. In the absence of instructions, refer to the National Fuel Gas Code, ANSI Z223.1/NFPA 54, Air for Combustion and Ventilation, or applicable local codes.

This heater is equipped with a **PILOT LIGHT SAFETY SYSTEM** designed to turn off the heater if not enough fresh air is available.

DO NOT TAMPER WITH PILOT LIGHT SAFETY SYSTEM!

If heater shuts off, do not relight until you provide fresh air.

If heater keeps shutting off, have it serviced. Keep burner and control compartment clean.

CARBON MONOXIDE POISONING MAY LEAD TO DEATH.

Early signs of carbon monoxide poisoning resemble the flu, with headache, dizziness and/or nausea. If you have these signs, heater may not be working properly. **GET FRESH AIR AT ONCE! HAVE HEATER SERVICED.**

Some people — pregnant women, persons with heart or lung disease, anemia, those under the influence of alcohol, those at high altitudes — are more affected by carbon monoxide than others.

The pilot light safety system senses the depletion of oxygen at its location. If this heater is installed in a structure having a high vertical dimension, the possibility exists that the oxygen supply at the higher levels will be less than that at the heater. In this type of application, a fan to circulate the structure air will minimize this effect. The use of this fan will also improve the comfort level in the structure. When a fan is used to circulate air, it should be located so that the air flow is not directed at the burner.

IMPORTANT SAFETY INFORMATION (CONT'D)

- **Sooting:** A vent-free fireplace or burner draws room air to support combustion. Lightweight particles suspended in the air – including dust, carpet fibers, candle or tobacco smoke, and pet hair – will be drawn toward the fireplace. These can lead to soot build up on fireplace walls, and even walls of the room. To prevent malfunctions and sooting, have your dealer perform an inspection and cleaning each year – before the heating season. If you have pets or excessive dust, more frequent cleaning may be necessary. See cleaning and service section in this manual.
- Do not place embers (rock wool) in this fireplace.
- Do not place lava rocks on burner.
- Installing a television above a fireplace has become a desirable feature; however, the following information should be considered.

All fireplaces, whether decorative or heater rated create heat. Most television manufacturers recommend not placing a television near a heat source. Because there is a large variety of television manufactures, styles and sizes, it is impractical to test every potential installation. If you choose to install a television above or near your fireplace, understand that Empire Comfort Systems accepts no responsibility for this decision and any injury or damage due to this application is the sole responsibility of the owner. Additionally, it is highly recommended to turn off the fireplace and let it cool down before servicing or using the operational buttons located on the television. In all cases, the television manufacturer's instructions and warnings should be followed.

SAFETY INFORMATION FOR USERS OF PROPANE GAS

Propane is a flammable gas which can cause fires and explosions. In its natural state, propane is odorless and colorless. You may not know all the following safety precautions which can protect both you and your family from an accident. Read them carefully now, then review them point by point with the members of your household. Someday when there may not be a minute to lose, everyone's safety will depend on knowing exactly what to do. If, after reading the following information, you feel you still need more information, please contact your gas supplier.

PROPANE GAS WARNING ODOR

If a gas leak happens, you should be able to smell the gas because of the odorant put in the Propane Gas. That's your signal to go into immediate action!

- Do not operate electric switches, light matches, use your phone. Do not do anything that could ignite the gas.
- Get everyone out of the building, vehicle, trailer, or area. Do that IMMEDIATELY.
- Close all gas tank or cylinder supply valves.
- Propane Gas is heavier than air and may settle in low areas such as basements. When you have reason to suspect a gas leak, keep out of basements and other low areas. Stay out until firefighters declare them to be safe.
- Use your neighbor's phone and call a trained Propane Gas service person and the fire department. Even though you may not continue to smell gas, do not turn on the gas again. Do not re-enter the building, vehicle, trailer, or area.
- Finally, let the service man and firefighters check for escaped gas. Have them air out the area before you return. Properly trained Propane Gas service people should repair the leak, then check and relight the gas appliance for you.

NO ODOR DETECTED - ODOR FADE

Some people cannot smell well. Some people cannot smell the odor of the chemical put into the gas. You must find out if you can smell the odorant in propane. Smoking can decrease your ability to smell. Being around an odor for a time can affect your sensitivity or ability to detect that odor. Sometimes other odors in the area mask the gas odor. People may not smell the gas odor or their minds are on something else. Thinking about smelling a gas odor can make it easier to smell.

The odorant in Propane Gas is colorless, and it can fade under some circumstances. For example, if there is an underground leak, the movement of the gas through soil can filter the odorant. Odorants in Propane Gas also are subject to oxidation. This fading can occur if there is rust inside the storage tank or in iron gas pipes. The odorant in escaped gas can adsorb or absorb onto or into walls, masonry and other materials and fabrics in a room. That will take some of the odorant out of the gas, reducing its odor intensity. Propane Gas may stratify in a closed area, and the odor intensity could vary at different levels. Since it is heavier than air, there may be more odor at lower levels. Always be sensitive to the slightest gas odor. If you detect any odor, treat it as a serious leak. Immediately go into action as instructed earlier.

SOME POINTS TO REMEMBER

- **Learn to recognize the odor of Propane Gas.** Your local Propane Gas Dealer can give you a "Scratch and Sniff" pamphlet. Use it to find out what the propane odor smells like. If you suspect that your Propane Gas has a weak or abnormal odor, call your Propane Gas Dealer.
- If you are not qualified, do not light pilot lights, perform service, or make adjustments to appliances on the Propane Gas system. If you are qualified, consciously think about the odor of Propane Gas prior to and while lighting pilot lights or performing service or making adjustments.
- Sometimes a basement or a closed-up house has a musty smell that can cover up the Propane Gas odor. Do not try to light pilot lights, perform service, or make adjustments in an area where the conditions are such that you may not detect the odor if there has been a leak of Propane Gas.
- Odor fade, due to oxidation by rust or adsorption on walls of new cylinders and tanks, is possible. Therefore, people should be particularly alert and careful when new tanks or cylinders are placed in service. Odor fade can occur in new tanks, or reinstalled old tanks, if they are filled and allowed to set too long before refilling. Cylinders and tanks which have been out of service for a time may develop internal rust which will cause odor fade. If such conditions are suspected to exist, a periodic sniff test of the gas is advisable. **If you have any question about the gas odor, call your Propane Gas Dealer. A periodic sniff test of the Propane Gas is a good safety measure under any condition.**

SAFETY INFORMATION FOR USERS OF PROPANE GAS (CONT'D)

- If, at any time, you do not smell the Propane Gas odorant and you think you should, assume you have a leak. Then take the same immediate action recommended above for the occasion when you do detect the odorized Propane Gas.
- If you experience a complete "gas out," (the container is under no vapor pressure), turn the tank valve off immediately. If the container valve is left on, the container may draw in some air through openings such as pilot light orifices. If this occurs, some new internal rusting could occur.

If the valve is left open, then treat the container as a new tank. Always be sure your container is under vapor pressure by turning it off at the container before it goes completely empty or having it refilled before it is completely empty.

IMPORTANT INSTALLATION GUIDELINES

PROPER LOG PLACEMENT

Log placement is critical to proper burner performance. Logs must be correctly positioned onto the burner. The photos in this manual show the proper pinned position for logs on this set. Owners need to be shown proper log placement and instructed not to move the logs.

Logs must fit firmly onto the burner when positioned as shown in the photos. Malformed logs or logs with sloppy pin holes must be replaced.

PROPER PLACEMENT OF ROCK WOOL AND DECORATIVE LAVA ROCK

Rock wool can be added to burners for a glowing ember effect. It must be positioned only on the front portion of the burner. The photos in this manual show the proper placement of rock wool.

Decorative lava rock or small wood pieces should never be placed on the burner. These items are only for placement on the floor of the fireplace or firebox.

PROPER PRIMARY AIRFLOW INTO BURNER

For proper burner operation and flame appearance, the flow of primary air into the venturi tube, located on the rear of the burner, must not be reduced. This flow of air is reduced if dirt, lint or other obstructions build-up around or inside the venturi. Any obstruction in the venturi tube area must be removed. The flow of air into the venturi is also reduced if the gas orifice isn't centered in the venturi inlet and/or is not aligned with the venturi. Any misalignment of the burner orifice may be corrected by bending the shutter cap holding the orifice to the inlet of the venturi tube.

CEILING FANS, PORTABLE FANS OR LOGS INSTALLED NEAR COLD AIR RETURNS

Ceiling fans or oscillating floor type fans need to be monitored during the operation of vent-free logs. If the air blows directly into the flame causing it to impinge on the log set, or firebox, it should be turned off or redirected. Ceiling fans could be reversed to possibly eliminate flame impingement, and the floor fan could be redirected. Upon installation, be aware of any cold air returns or vents in the proximity of the log set. Any draft created around a vent-free log set can cause the flame to impinge on the log and create a sooting situation.

WARNING

Do not allow fans to blow directly into the fireplace. Avoid any drafts that alter burner flame patterns.

WARNING

Do not use a blower insert, heat exchanger insert or other accessory not approved for use with this heater.

CANDLES

Avoid the use of scented or decorative candles while the log set is in operation. Candles produce a residue in the air that creates a soot like substance. Burning candles while the log set is operating magnifies the problem. It should be noted that candles, in general, produce soot. The amount of time burned and the quantity of candles burned will determine the amount of soot produced and deposited.

MAKE OWNERS AWARE OF PROPER LOG SET OPERATION

Properly installed and properly maintained log sets do not deposit soot on the logs. If users see soot appear on a log, call for service. Do not continue to operate the log set.

This appliance is only for use with the type of gas indicated on the rating plate and may be installed in an aftermarket, permanently located, manufactured (mobile) home where not prohibited by local codes. This appliance is not convertible for use with other gases.

CAUTION

Do not operate the appliance with panel(s) removed, cracked or broken. Replacement of the panel(s) should be done by a licensed or qualified service person.

WARNING

Improper installation, adjustment, alteration, service or maintenance can cause property damage, personal injury or loss of life. Installation and service must be performed by a qualified installer, service agency or the gas supplier.

INTRODUCTION

Instructions to Installer

1. Installer must leave instruction manual with owner after installation.
2. Installer must have owner fill out and mail warranty card supplied with unvented room heater.
3. Installer should show owner how to start and operate unvented room heater.

Always consult your local Building Department regarding regulations, codes or ordinances which apply to the installation of an unvented room heater.

This appliance may be installed in an aftermarket* manufactured (mobile) home, where not prohibited by state or local codes.

*Aftermarket: Completion of sale, not for purpose of resale, from the manufacturer.

Well Head Gas Installations

Some natural gas utilities use "well head" gas. This may affect the Btu output of the unit and promote sooting. Units shall not be converted to use well head gas.

This appliance is only for use with the type of gas indicated on the rating plate. This appliance is not convertible for use with other gases.

WARNING

Any change to this heater or its controls can be dangerous. Improper installation or use of the heater can cause serious injury or death from fire, burns, explosion or carbon monoxide poisoning.

This series is design certified in accordance with American National Standard Z21.11.2 by the Canadian Standards Association Laboratories as an Unvented Room Heater and should be installed according to these instructions.

Any alteration of the original design, installed other than as shown in these instructions or use with a type of gas not shown on the rating plate is the responsibility of the person and company making the change.

VFLC(10,20,28)IN32 Series Only 750 Millivolt System

When you ignite the pilot, the thermocouple produces millivolts (electrical current) which energizes the magnet in the gas valve. After 30 seconds to 1 minute time period you can release the gas control knob and the pilot will stay ON. Allow your pilot flame to operate an additional one to two minutes before you turn the gas control knob from the PILOT position to the ON position. This time period allows the millivolts (electrical energy) to build-up to a sufficient level allowing the gas control to operate properly.

Important

All correspondence should refer to complete Model Number, Serial Number and type of gas.

NOTICE: During initial firing of this unit, its paint will bake out, and smoke will occur. To prevent triggering of smoke alarms, ventilate the room in which the unit is installed.

Installation on Rugs and Tile

If this appliance is installed directly on carpeting, tile or other combustible material other than wood flooring the appliance shall be installed on a metal or wood panel extending the full width and depth of the appliance.

The base referred to above does not mean the fire-proof base as used on wood stoves. The protection is for rugs that are extremely thick and light colored tile.

Solid-fuels shall not be burned in a masonry or *UL 127* factory-built fireplace in which an unvented room heater is installed.

Qualified Installing Agency

Installation and replacement of gas piping, gas utilization equipment or accessories and repair and servicing of equipment shall be performed only by a qualified agency. The term "qualified agency" means any individual, firm, corporation or company which either in person or through a representative is engaged in and is responsible for (a) the installation or replacement of gas piping or (b) the connection, installation, repair or servicing of equipment, who is experienced in such work, familiar with all precautions required and has complied with all the requirements of the authority having jurisdiction.

Commonwealth of Massachusetts: The installation must be made by a licensed plumber or gas fitter in the Commonwealth of Massachusetts.

Sellers of unvented propane or natural gas-fired supplemental room heaters shall provide to each purchaser a copy of 527 CMR 30 upon sale of the unit.

In the Commonwealth of Massachusetts, unvented propane and natural gas-fired space heaters shall be prohibited in bedrooms and bathrooms.

The installation must conform with local codes or, in the absence of local codes, with the National Fuel Gas Code, ANSI Z223.1.*

*Available from the American National Standards Institute, Inc. 1430 Broadway, New York, N.Y. 10018.

WARNING

This appliance is equipped for natural gas or propane gas. Field conversion is not permitted.

SPECIFICATIONS

VFLC10IN32	Propane	Natural
Input Btu/hr Maximum	10,000	10,000
Input Btu/hr Minimum	10,000	10,000
Orifice	#64	#53
Air Shutter Opening	3/16"	1/16"
VFLC20IN32	Propane	Natural
Input Btu/hr Maximum	20,000	20,000
Input Btu/hr Minimum	16,000	13,000
Orifice	#55	2.1mm
Air Shutter Opening	3/16"	1/16"
VFLC20IN72	Propane	Natural
Input Btu/hr Maximum	20,000	20,000
Input Btu/hr Minimum	14,000	13,000
Orifice	#55	2.1mm
Air Shutter Opening	3/16"	1/16"
VFLC28IN32	Propane	Natural
Input Btu/hr Maximum	28,000	28,000
Input Btu/hr Minimum	23,000	19,000
Orifice	1.55	#40
Air Shutter Opening	3/16"	1/16"
VFLC28IN72	Propane	Natural
Input Btu/hr Maximum	28,000	28,000
Input Btu/hr Minimum	23,000	19,000
Orifice	1.55	#40
Air Shutter Opening	3/16"	1/16"

All units require the use of one of the following surrounds.
See pages 13 and 14.

Surround Kit	Description
DS20433BL	Metal Surround 3-Sided, 1-Piece, (4x3x1) Matte Black (34Wx21.5Hx1D) <i>For Use With VFLC(10,20)IN Inserts</i>
DS20763BL	Metal Surround 3-Sided, 1-Piece, (7x6x1) Matte Black (40Wx24.5Hx1D) <i>For Use With VFLC(10,20)IN Inserts</i>
DS28433BL	Metal Surround 3-Sided, 1-Piece, (4x3x1) Matte Black (37Wx24.5Hx1D) <i>For Use With VFLC28IN Inserts</i>
DS28761BL	Metal Surround 3-Sided, 1-Piece, (4x3x1) Matte Black (43Wx27.5Hx1D) <i>For Use With VFLC28IN Inserts</i>
DS20334BL	Metal Surround 4-Sided, 1-Piece, Matte Black (34Wx22-7/8Hx1/8D) <i>For Use With VFLC20IN Inserts</i>
DS28334BL	Metal Surround 4-Sided, 1-Piece, Matte Black (37Wx25-7/8Hx1/8D) <i>For Use With VFLC28IN Inserts</i>

Surround Kit (Continued)	Description
SC256BL	Cast Iron Surround (for use with VFLC(10,20)IN Inserts) NOTE: SAN20 Adaptor Kit Required
SC336BL	Cast Iron Surround (for use with VFLC28IN Inserts) NOTE: SAN28 Adaptor Kit Required

Adaptor Kit	Description
SAN20	Surround Adaptor Kit - Required For Cast Iron Surround With VFLC(10,20)IN Inserts
SAN28	Surround Adaptor Kit - Required For Cast Iron Surround With VFLC28IN Inserts

Optional Control Accessories	
Remote Control Accessories	Description
FRBC	Millivolt/IP Battery Operated Remote Control
FRBTC	Millivolt/IP Battery Operated Remote Control with Thermostat
FRBTP	Battery Operated Programmable Remote Control
FWS-1	Direct Ignition/Millivolt/IP Wall Switch
TRW	Millivolt/IP Remote Wall Thermostat (Wireless)
TMV	Millivolt/IP Wall Thermostat, - Reed Switch
FREC	Electric Remote Control
RVKN	Variable Remote Kit - IP Natural
RVKP	Variable Remote Kit - IP Propane

VFLC(10,20,28)IN Optional Accessories	
Part Number	Description
FBB7	Variable Speed Blower
DG-1-BKP	Decorative Glass Black Polished
DG-1-BUC	Decorative Glass Blue Clear
DG-1-CLF	Decorative Glass Frost

Optional decorative glass and rocks are available in several different sizes and colors. Contact your Empire Dealer for more information.

INSTALLATION IN A FIREPLACE

1. First check to make sure there is no hidden damage to the unit. Take a minute and plan out the gas and electrical route. It is best to start with the gas line first, followed by the electrical supply requirements.
2. Minimum fireplace opening requirements are shown in **Figure 2** of this installation manual. The firebrick (refractory), glass doors, screen rails, screen mesh and log grates can be removed from a fireplace in order to gain minimum gas insert opening requirements prior to installing the gas fireplace insert.

CAUTION

Determine the total thickness of finishing materials (i.e. stone, brick or marble) so that the proper dimensions can be maintained for installing the fireplace and decorative fronts.

3. Although the insert does not require a hearth extension, only heat resistant materials such as stone, metal, tile, etc. should be used. Do not use vinyl, carpet, or wood based products within 16 inches of the insert face. Do not obstruct the lower vented openings on the insert. **NOTE:** The original fireplace cannot be returned to solid fuel use without returning the hearth extension to the specification required for a solid fuel fireplace.
4. The side walls, top and floor structures of the firebox may not be altered with the exception of removable baffles and dampers. Smoke shields, shelves and baffles may be removed. The original fireplace cannot be returned to solid fuel in this condition.
5. The insert surround is tested and approved with this gas insert and may cover existing air circulation vents or grills on the solid fuel fireplace it is installed into. If the surround does not cover the entire ventilation grill surface, the exposed grill area should be left open.

NOTICE: Cutting any sheet-metal from the decommissioned fireplace or firebox for the installation of zero-clearance unvented fireplace insert, may be necessary and is acceptable in this application.

NOTICE: The following statement is also provided on a separate label plate in the instruction packet. Prior to installation of the fireplace insert, the installer must mechanically secure this warning plate to the inside of the fireplace for future reference as required.

WARNING

The solid fuel fireplace has been converted for use with gas only and cannot be used for burning wood or solid fuels unless all original parts have been replaced and the fireplace has been reapproved by the authority having jurisdiction.

Positioning, Leveling and Securing Insert

6. Place the insert into position

NOTICE: The front flanges of the insert (without surround panels) should be set at approximately 1" in front of the face of the fireplace.

7. Level the insert from side to side and front to back.
8. If necessary, use the leveling bolts included in the instruction pack. Screw the legs into the nuts installed in the bottom of the insert. Turn legs in until insert is level.

NOTICE: The best way to access the leveling bolt locations is to remove the burner and firebox bottom.

NOTICE: If desired, it is acceptable to attach metal strapping or brackets (not provided) from the fireplace cavity to the insert outer jacket to secure the fireplace insert to the fireplace hearth or opening.

9. Install the insert without the surround panels attached and make all gas venting and electrical connections. If the control module, receiver and other electrical devices are pulled out to install the gas line, they must be placed back into the location where they were from the factory. The gas flexline may cross over the control module.

WARNING

Verify that all wire connections are secure.

If the factory built fireplace does not have gas access holes provided, an access hole of 1 1/2" diameter (37.5mm) or less may be drilled through the lower sides or bottom of the firebox in a proper workmanship like manner. This access hole must be plugged with a non-combustible insulation after the gas supply line has been installed.

10. The surround panel assembly is attached to the fireplace after it has been installed with all the gas and electrical connections completed. Refer to instructions included with the surround panel kit.

FIREPLACE INSERT DIMENSIONS

When planning a fireplace insert installation, it's necessary to determine:

- Gas supply piping.
- Electrical connections - for optional blower

- Whether optional accessories - devices such as a wall switch or remote control - are desired.
- Electrical supply requirements for optional blower. (120V, 60Hz, 1 Amp)
- Proper opening size of fireplace required for installation of the fireplace insert.

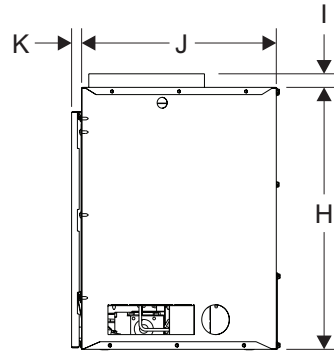
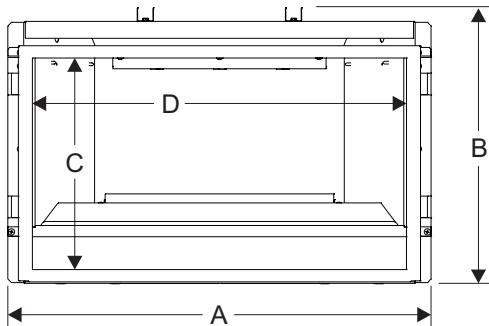
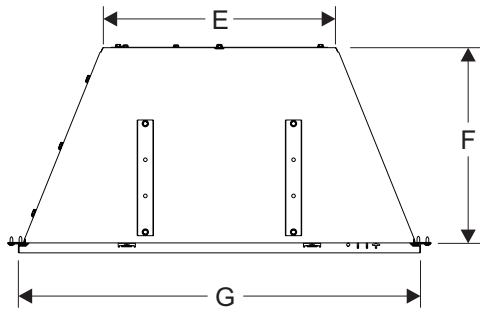

VF FIREPLACE INSERT DIMENSIONS											
Model	A	B	C	D	E	F	G	H	I	J	K
VFLC(10,20)IN	29 1/4"	19 1/8"	14 5/8"	25 7/8"	16 3/16"	13 9/16"	27 13/16"	18 1/8"	15/16"	13 9/16"	11/16"
VFLC28IN	32 1/4"	22 1/8"	17 5/8"	28 7/8"	17 13/16"	15 1/16"	30 13/16"	21 1/8"	15/16"	14 15/16"	11/16"

Figure 1

FIREPLACE OPENING DIMENSIONAL INFORMATION/SIZING				
Minimum Fireplace Opening Dimensions				
Model	Height A	Front Width B	Depth C	Rear Width D
VFLC(10,20)IN	19 3/8"	27 1/2" *	13 1/2"	15 3/4"
VFLC28IN	22 3/8"	30 1/2" *	15	19"

NOTICE: These are the minimum dimensions of a fireplace that the fireplace insert will fit into. It allows room for the box and the fireplace surround to fit onto the front of the unit. It is not intended to be used for framing dimensions. Refer to **Figures 3 to 5** for framing dimensions.

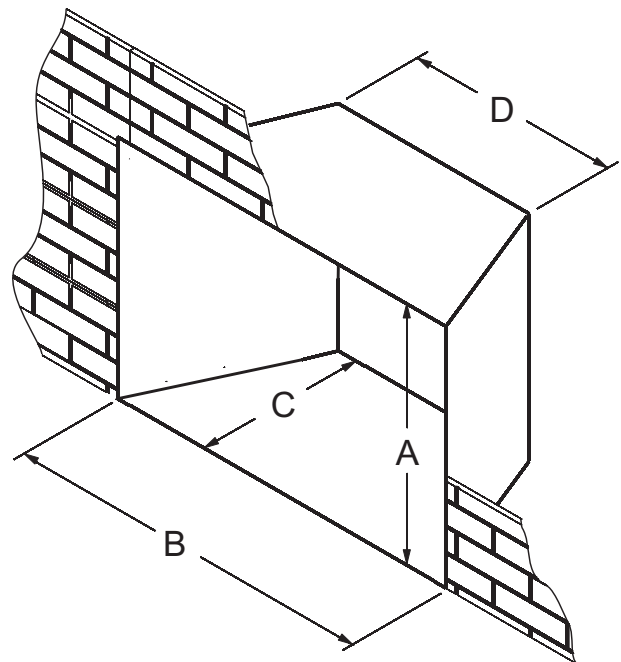

Figure 2

BUILT-IN FIREPLACE INSTALLATION

In planning the installation for the fireplace, it is necessary to determine where the unit is to be installed and whether optional accessories are desired. Gas supply piping should also be planned at this time.

The fireplace can be mounted on any of these surfaces:

1. A flat hard combustible or non-combustible surface.
2. A raised platform of combustible or non-combustible material.
3. Four corners of the fireplace so contact is made on all four perimeter edges on the bottom of the unit.
(Example: Four concrete masonry blocks.)

This unit is designed to be installed in a zero-clearance enclosure. This means the combustible material can come in contact with the firebox.

Built-In Fireplace Installation

Built-in installation of this fireplace involves installing the fireplace into a framed-in enclosure. This makes the front of the fireplace flush with a wall.

Frame in rough opening. Use dimensions show in **Figure 3** for a conventional rough opening. Use dimensions shown in **Figure 4** for corner rough opening. Use **Figure 5** for an elevated installation. Be sure to provide support to the bottom of the fireplace. Be sure to provide gas line for fireplace and electrical power for a blower assembly, if included.

Although the insert does not require a hearth extension, only heat resistant materials such as stone, metal, tile, etc. should be used. Do not use vinyl, carpet, or wood based products within 16 inches of the insert face. Do not obstruct the lower vented openings on the insert.

1. Gas line connections must be made at this time. When facing the appliance, the gas supply will enter on the right-hand side. See "Gas Supply" page 18 to 19.
2. Insert fireplace into enclosure.
3. Level firebox.
4. Finished wall surface will be flush to the back edges of surround top and sides.
5. The surround panel assembly is installed after the fireplace has been installed with all the gas and electrical connection completed. Refer to instructions included with the surround panel kit.
6. Installation of built-in fireplace is completed.

	Rough Opening for Installing in Wall		Rough Opening for Installing in Corner		Rough Opening for Elevated Installation	
	Figure 3		Figure 4		Figure 5	
MODELS	A	B	C	D	E	F
VFLC20IN	13 1/2" (343 mm)	27 1/2" (698.5 mm)	19 3/8" (492 mm)	36 1/4" (920.8 mm)	43 1/4" Min. (1,098.6 mm)	21 5/8" (549.3 mm)
VFLC28IN	15" (381 mm)	30 1/2" (774.7 mm)	22 3/8" (568 mm)	36 1/4" (920.8 mm)	48" Min. (1,219.2 mm)	24" (609.6 mm)

VFLC(10,20)IN FIREPLACE SURROUND DIMENSIONS

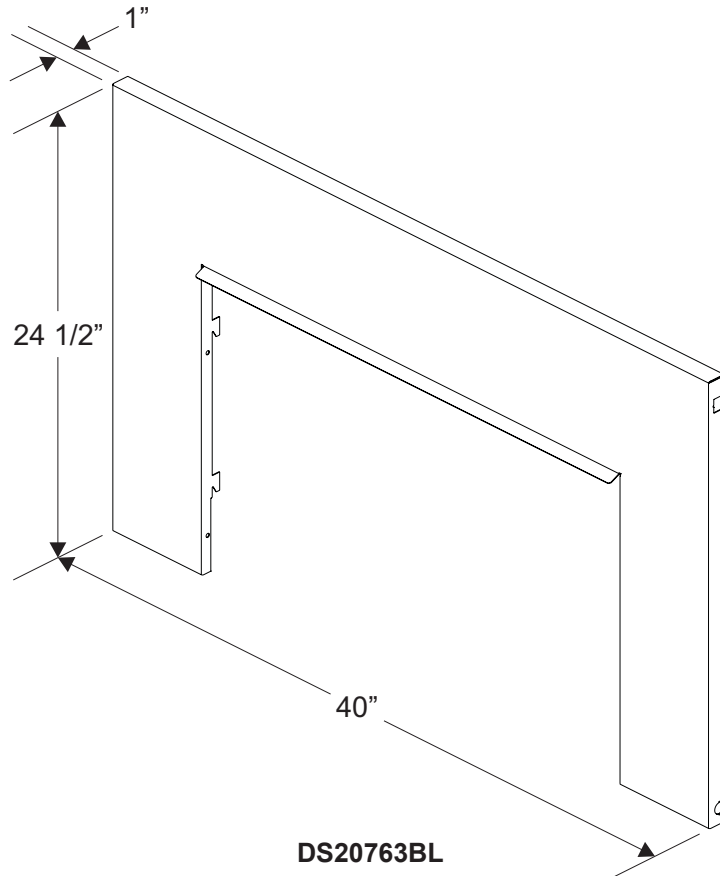
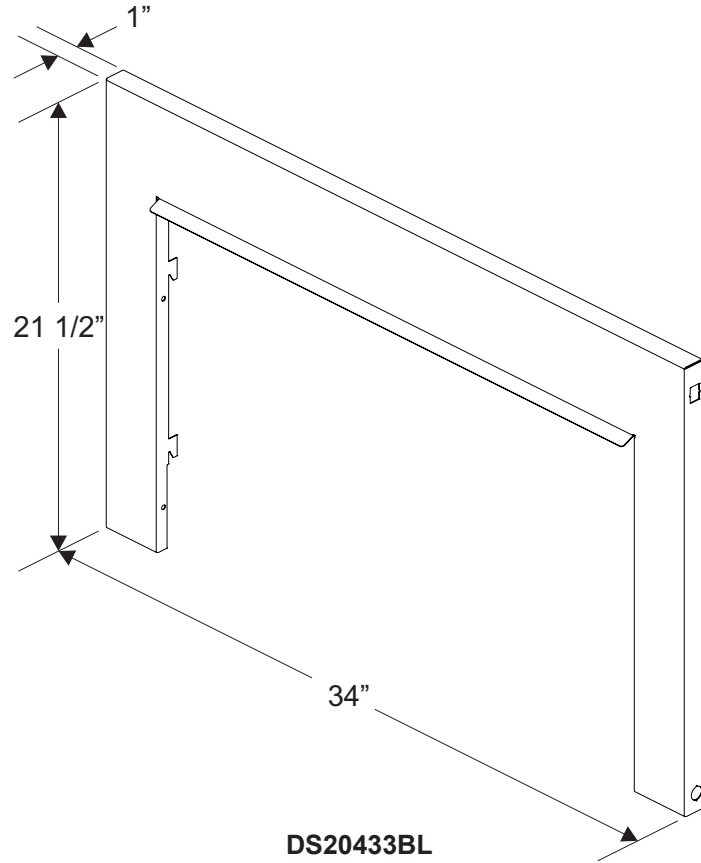

VFLC28IN FIREPLACE SURROUND DIMENSIONS

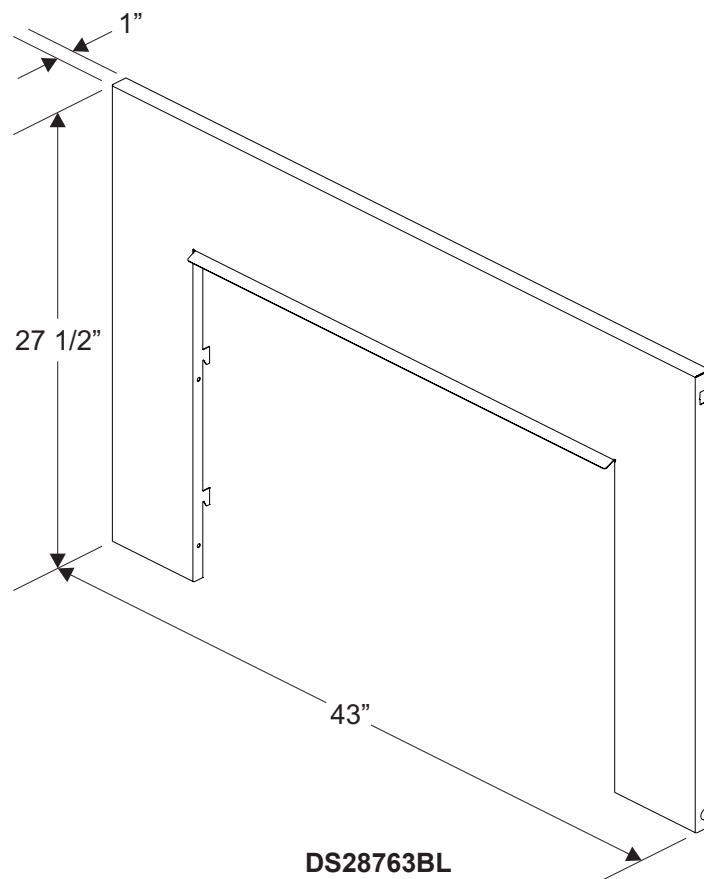
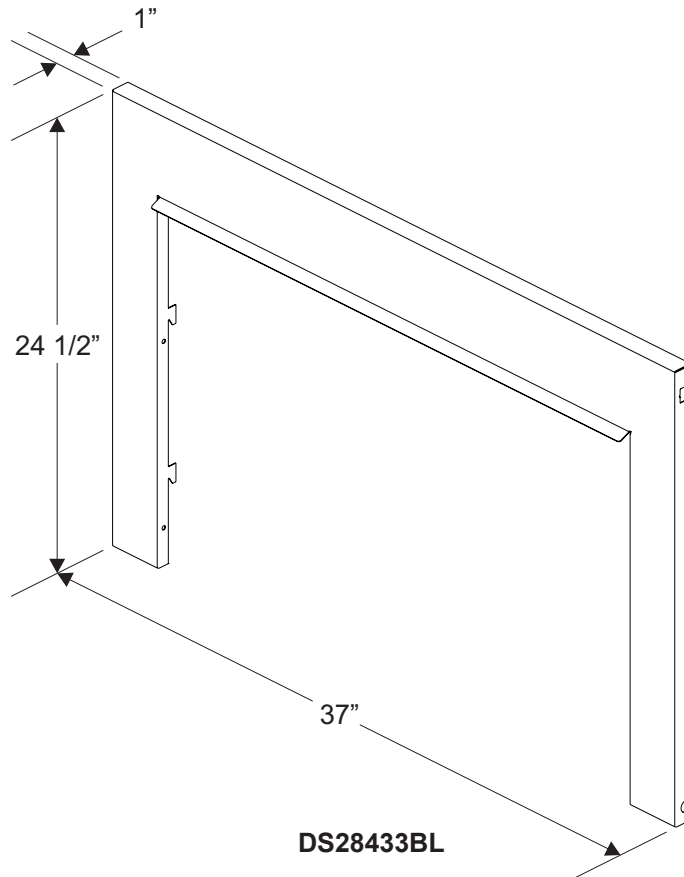

ALTERNATE ON/OFF SWITCH INSTALLATION

Cast Iron Surrounds

Cast Iron Surrounds require a surround adaptor kit. See page 9 for kit information.

1. Find the coiled low voltage wire assembly and ON/OFF switch located in the instruction packet.
- 2a. Attach the flag terminal ends to the "TH/TP" and "TH" terminals on the front terminal block of the MV gas valve.
See Figure 18.
- 2b. Attach the flag terminals to the green and white wire terminals located in the bottom of the insert near the gas valve. **See Figures 19 and 20.**
3. Run the low voltage alternate switch wires up the back of the right or left cast surround leg. Then secure them with the wire clips provided.
4. Install the switch bracket with screws as shown in **Figure 6** to the back of the cast surround leg.

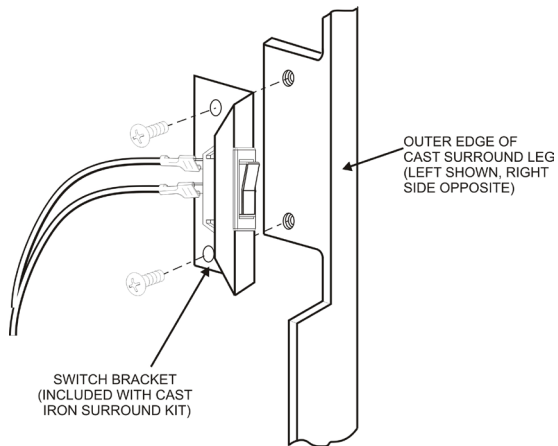

Figure 6

NOTICE: For right side leg installation, reverse switch position in bracket.

5. Install ON/OFF switch, and connect low-voltage wires from gas valve (MV) or control module (IP).
6. Attach cast surround panel assembly to the insert. Place the cast surround assembly to the face of the insert. Align the inside brackets on the cast surround with the flanges on the insert. Install four #8 x 1/2 truss head sheet metal screws to secure the surround.

WATER VAPOR: A BY-PRODUCT OF UNVENTED ROOM HEATERS

Water vapor is a by-product of gas combustion. An unvented room heater produces approximately one ounce (30ml) of water for every 1,000 BTU's (.3KW's) of gas input per hour.

Unvented room heaters are recommended as supplemental heat (a room) rather than a primary heat source (an entire house). In most supplemental heat applications, the water vapor does not create a problem. In most applications, the water vapor enhances the low humidity atmosphere experienced during cold weather.

The following steps will help insure that water vapor does not become a problem.

1. Be sure the heater is sized properly for the application, including ample combustion air and circulation air.
2. If high humidity is experienced, a dehumidifier may be used to help lower the water vapor content of the air.
3. Do not use an unvented room heater as the primary heat source.

PROVISIONS FOR ADEQUATE COMBUSTION & VENTILATION AIR

This heater shall not be installed in a confined space or unusually tight construction unless provisions are provided for adequate combustion and ventilation air.

Installation in a Confined Space

A confined space is an area with volume less than 50 cubic feet per 1,000 Btuh of the combined input rates of all appliances drawing combustion air from that space. Small areas such as equipment rooms are confined spaces. Furnaces installed in a confined space which supply heated air to areas outside the space must draw return air from outside the space through tightly sealed return air ducts. A confined space must have 2 openings into the space for combustion air. One opening must be within 12 inches of the ceiling and the other must be within 12 inches of the floor. The required sizing of these openings is determined by whether inside or outside air is used to support combustion, the method by which the air is brought to the space (vertical or horizontal duct) and by the total input rate of all appliances in the space.

Unusually Tight Construction

The air that leaks around doors and windows may provide enough fresh air for combustion and ventilation. However, in buildings of unusually tight construction, you must provide additional fresh air.

Unusually tight construction is defined as construction where:

- a. Walls and ceilings exposed to the outside atmosphere have a continuous water vapor retarder with a rating of one perm or less with openings gasketed or sealed, and
- b. Weather-stripping has been added on openable windows and doors, and
- c. Caulking or sealants are applied to areas such as joints around window and door frames, between sole plates and floors, between wall-ceiling joints, between wall panels, at penetrations for plumbing, electrical, and gas lines, and at other openings.

If your home meets all of the three criteria above, you must provide additional fresh air. See "**Ventilation Air From Outdoors**," page 14.

Determining if You Have a Confined or Unconfined Space

Use this worksheet to determine if you have a confined or unconfined space.

Space: Includes the room in which you will install heater plus any adjoining rooms with doorless passageways or ventilation grills between the rooms.

1. Determine the volume of the space (length x width x height).
Length x Width x Height = _____ cu. ft. (volume of space)

Example: Space size 16 ft. (length) x 10 ft. (width) x 8 ft. (ceiling height) = 1,280 cu. ft. (volume of space)

If additional ventilation to adjoining room is supplied with grills or openings, add the volume of these rooms to the total volume of the space.

2. Divide the space volume by 50 cubic feet to determine the maximum BTU/Hr the space can support.
_____ (volume of space) ÷ 50 cu. ft. = (maximum BTU/Hr the space can support)

Example: 1,280 cu. ft. (volume of space) ÷ 50 cu. ft. = 25.6 or 25,600 (maximum BTU/Hr the space can support)

3. Add the BTU/Hr of all fuel burning appliances in the space.

Vent-free heater			_____ BTU/Hr
Gas water heater			_____ BTU/Hr
Gas furnace			_____ BTU/Hr
Vented gas heater			_____ BTU/Hr
Gas fireplace logs			_____ BTU/Hr
Other gas appliances*	+		_____ BTU/Hr
Total		=	_____ BTU/Hr

Example:

Vented gas heater			20,000 BTU/Hr
Vent-free heater	+		+ 18,000 BTU/Hr
Total		=	38,000 BTU/Hr

*Do not include direct-vent gas appliances. Direct vent draws combustion air from the outdoors and vents to the outdoors.

4. Compare the maximum BTU/Hr the space can support with the actual amount of BTU/Hr used.
_____ BTU/Hr (maximum the space can support)
_____ BTU/Hr (actual amount of BTU/Hr used)

Example:

25,600			BTU/Hr (maximum the space can support)
38,000			BTU/Hr (actual amount of BTU/Hr used)

⚠ WARNING

If the area in which the heater may be operated is smaller than that defined as an unconfined space or if the building is of unusually tight construction, provide adequate combustion and ventilation air by one of the methods described in the National Fuel Gas Code, ANSI Z223.1/NFPA 54, Air for Combustion and Ventilation, or applicable local codes.

PROVISIONS FOR ADEQUATE COMBUSTION & VENTILATION AIR (CONT'D)

The space in the above example is a confined space because the actual BTU/Hr used is more than the maximum BTU/HR the space can support. You must provide additional fresh air. Your options are as follows:

- A. Rework worksheet, adding the space of an adjoining room. If the extra space provides an unconfined space, remove door to adjoining room or add ventilation grills between rooms. See **Ventilation Air From Inside Building**.
- B. Vent room directly to the outdoors. See **Ventilation Air From Outdoors**.
- C. Install a lower BTU/Hr heater, if lower BTU/Hr size makes room unconfined.

If the actual BTU/Hr used is less than the maximum BTU/Hr the space can support, the space is an unconfined space. You will need no additional fresh air ventilation.

⚠ WARNING

You must provide additional ventilation air in a confined space.

Ventilation Air

Ventilation Air From Inside Building

This fresh air would come from an adjoining unconfined space. When ventilating to an adjoining unconfined space, you must provide two permanent openings: one within 12" of the ceiling and one within 12" of the floor on the wall connecting the two spaces (see options 1 and 2, **Figure 7**). You can also remove door into adjoining room (see option 3, **Figure 7**). Each ventilation grill or opening shall have a minimum free area of one square inch per 1,000 BTUH of the total input rating of the gas equipment in the confined space.

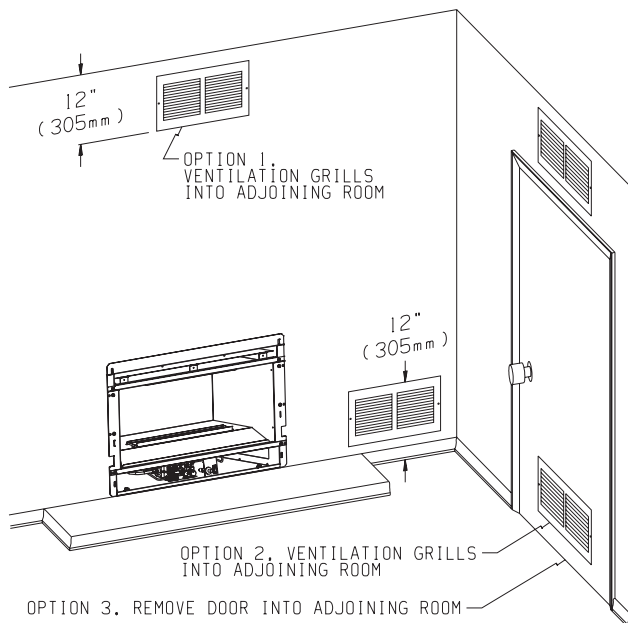

Figure 7

⚠ WARNING

Rework worksheet, adding the space of the adjoining unconfined space. The combined spaces must have enough fresh air to supply all appliances in both spaces.

Ventilation Air From Outdoors

Provide extra fresh air by using ventilation grills or ducts. You must provide two permanent openings: one within 12" of the ceiling and one with 12" of the floor. Connect these items directly to the outdoors or spaces open to the outdoors. These spaces include attics and crawl spaces. In most cases for direct communication with the outdoors or direct communication through a vertical duct a free area opening of one square inch per 4,000 BTU/Hr of heater input rating for each grill. If a horizontal duct is used, a grill free area or duct opening shall have a free area opening of one square inch per 2,000 BTU/Hr for each grill. Follow the *National Fuel Code ANSI Z223.1/NFPA54, Air for Combustion and Ventilation* for required size of ventilation grills or ducts.

IMPORTANT: Do not provide openings for inlet or outlet air into attic if attic has a thermostat-controlled power vent. Heated air entering the attic will activate the power vent.

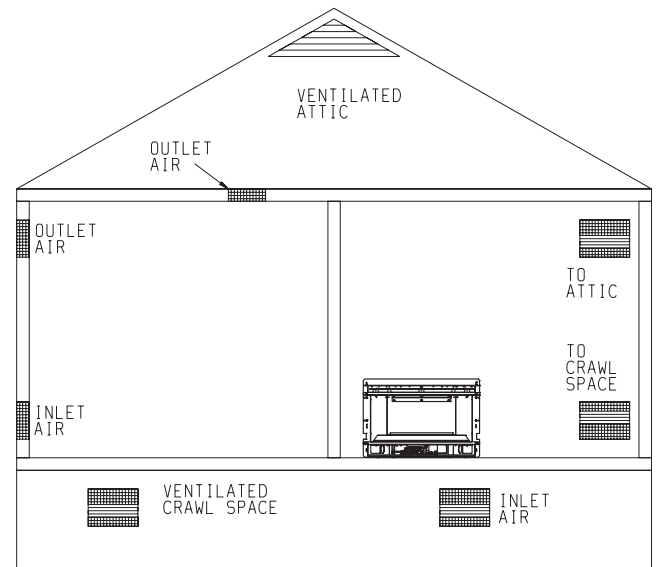

Figure 8

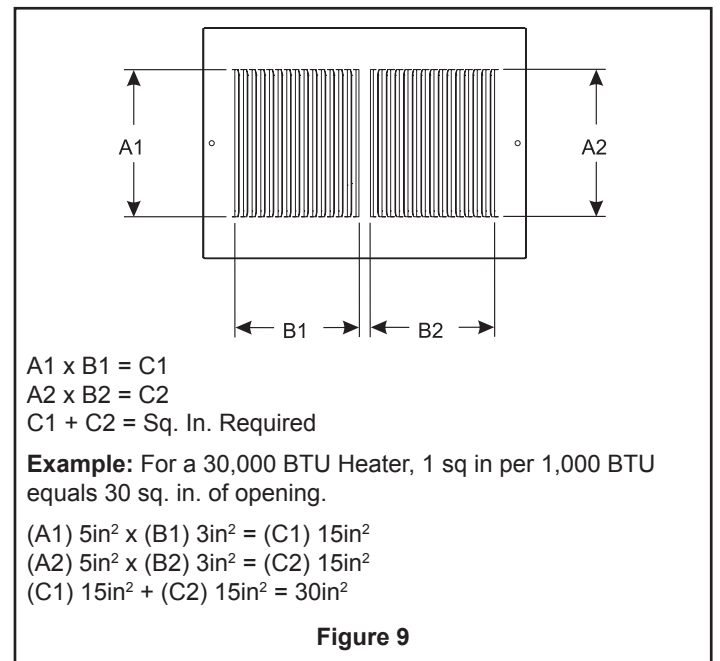

Figure 9

GAS SUPPLY

The gas pipeline can be brought in through the right or left side of the appliance. The insert has a Flexline with shutoff valve located on the right side when facing the unit. **See Figures 10 and 11.** Consult the current National Fuel Gas Code, ANSI Z223.1 CAN/CGA-B149 (.1 or .2) installation code.

RECOMMENDED GAS PIPE DIAMETER				
Pipe Length	Schedule 40 Pipe Inside Diameter		Tubing, Type L Outside Diameter	
	Natural	Propane	Natural	Propane
0-10ft 0-3m	1/2" 12.7mm	3/8" 9.5mm	1/2" 12.7mm	3/8" 9.5mm
11-40ft 4-12m	1/2" 12.7mm	1/2" 12.7mm	5/8" 15.9mm	1/2" 12.7mm
41-100ft 13-30m	1/2" 12.7mm	1/2" 12.7mm	3/4" 19mm	1/2" 12.7mm
101-150ft 31-46m	3/4" 19mm	1/2" 12.7mm	7/8" 22.2mm	3/4" 19mm

⚠ CAUTION

Never use plastic pipe. Check to confirm whether your local codes allow copper tubing or galvanized.

NOTICE: Since some municipalities have additional local codes, it is always best to consult your local authority and installation code. The use of the following gas connectors is recommended:

- ANS Z21.24 Appliance Connectors of Corrugated Metal Tubing and Fittings.
- ANS Z21.45 Assembled Flexible Appliance Connectors of Other Than All-Metal Construction

The above connectors may be used if acceptable by the authority having jurisdiction. The Commonwealth of Massachusetts requires that a flexible appliance connector cannot exceed three feet in length.

FLEXIBLE GAS LINE CONNECTION

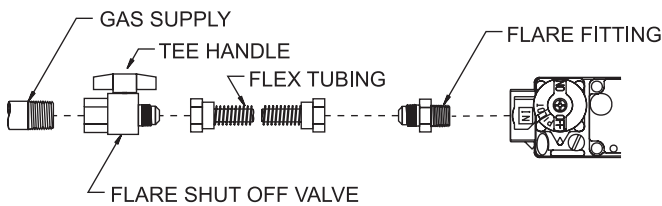

Figure 10

Installing the Main Gas Shut-Off

Each appliance should have its own manual gas shut-off. A manual main gas shut-off should be located in the vicinity of the unit. Where none exists, or where its size or location is not adequate, contact your local authorized installer for installation or relocation. Compounds used on threaded joints of gas piping shall be resistant to the action of liquefied petroleum gases. The gas lines must be checked for leaks by the installer. This should be done with a soap solution watching for bubbles on all exposed connections, and if unexposed, a pressure test should be made.

Never use an exposed flame to check for leaks. Appliance must be disconnected from piping at inlet of control valve and pipe capped or plugged for pressure test. Never pressure test with appliance connected; control valve will sustain damage!

NOTICE: The millivolt gas controls are equipped with a captured screw type pressure test point, therefore it is not necessary to provide a 1/8" test point up stream of the control.

When using copper or flex connector use only approved fittings. The appliance and it's individual shut off valve must be disconnected from supply piping system during any pressure testing of that system at test pressures in excess of 1/2 psig (3.5kPa).

The appliance must be isolated from the gas supply piping system by closing its individual manual shut off valve during any pressure testing of the gas supply piping system at test pressures equal to or less than 1/2 psig (3.5kPa).

Attention! If one of the procedures results in pressures in excess of 1/2 psig (14" w.c.) (3.5 kPa) on the fireplace gas valve, it will result in a hazardous condition.

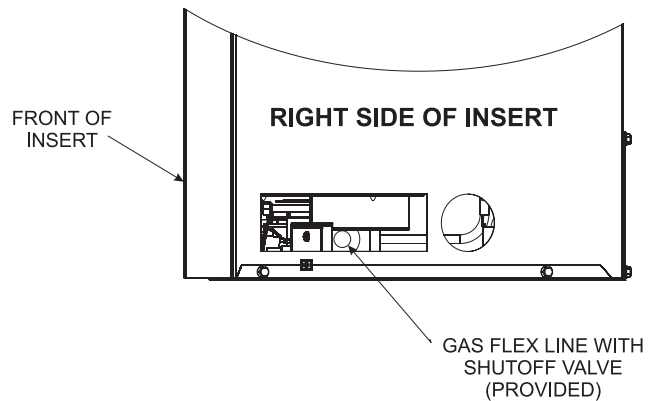

Figure 11

GAS SUPPLY (CONT'D)

Checking Manifold Pressure

MILLIVOLT VALVES

Natural Gas will have a manifold pressure of approximately 3.5" w.c. for maximum input or 1.7" w.c. for minimum input at the pressure regulator outlet with the inlet pressure to the pressure regulator from a minimum of 4.5" w.c. for the purpose of input adjustment to a maximum of 10.5" w.c.

Propane Gas will have a manifold pressure approximately 10.0" w.c. (2.49kPa) for maximum input or 4.9" w.c. for minimum input at the pressure regulator outlet with the inlet pressure to the pressure regulator from a minimum of 11.0" w.c. for the purpose of input adjustment to a maximum of 13.0" w.c.

INTERMITTENT PILOT VALVES

Natural Gas will have a manifold pressure of approximately 3.5" w.c. at the pressure regulator outlet with the inlet pressure to the pressure regulator from a minimum of 7.0" w.c. for the purpose of input adjustment to a maximum of 10.5" w.c.

Propane Gas will have a manifold pressure approximately 10.0" w.c. at the pressure regulator outlet with the inlet pressure to the pressure regulator from a minimum of 11.0" w.c. for the purpose of input adjustment to a maximum of 13.0" w.c. .

Control Valve - Gas Pressure Check

The valve regulator controls the burner pressure which should be checked at the pressure test point. Turn captured screw counter clockwise 2 or 3 turns and then place tubing to pressure gauge over test point (Use test point "A" closest to control knob). After taking pressure reading, **be sure and turn captured screw clockwise firmly to re-seal**. Do not over torque. Check for gas leaks.

(COMBUSTIBLE) CLEARANCES

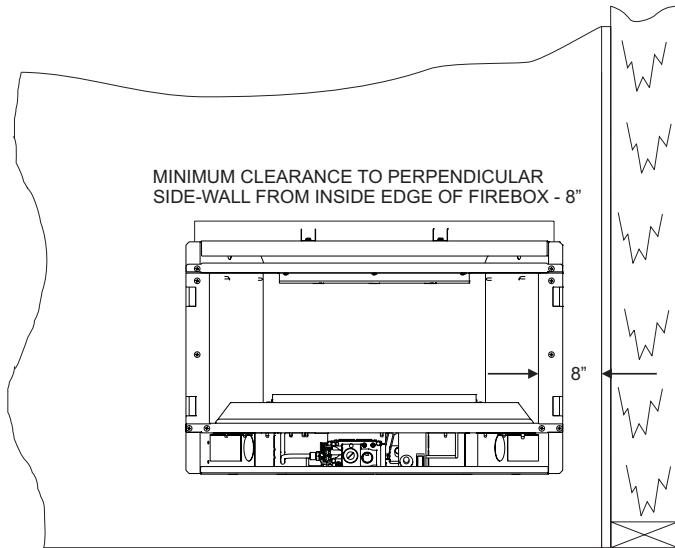
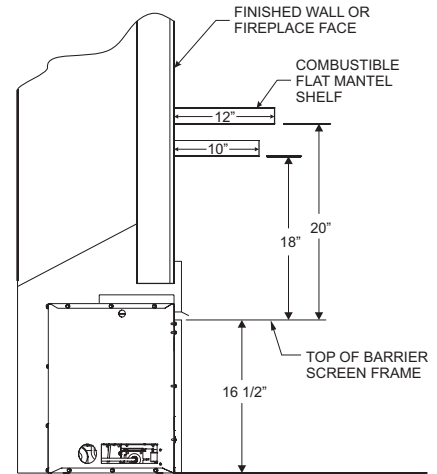
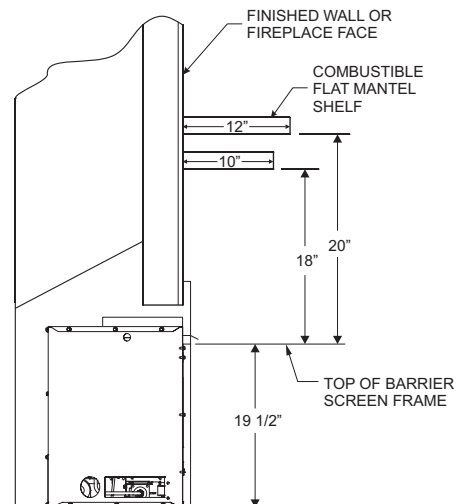

Figure 12



VFLC10 AND VFLC20 SERIES

Figure 13



VFLC28 SERIES

Figure 14

COMBUSTIBLE MATERIALS

Combustible Material

No greeting cards, stockings or ornamentation of any type should be placed on or attached to the fireplace. The flow of heat can ignite combustibles.

Do not attach combustible material to the mantel of your fireplace. This is a fire hazard.

No greeting cards, stockings or ornamentation of any type should be placed on or attached to the fireplace. This is a heating appliance. The flow of heat can ignite combustibles.

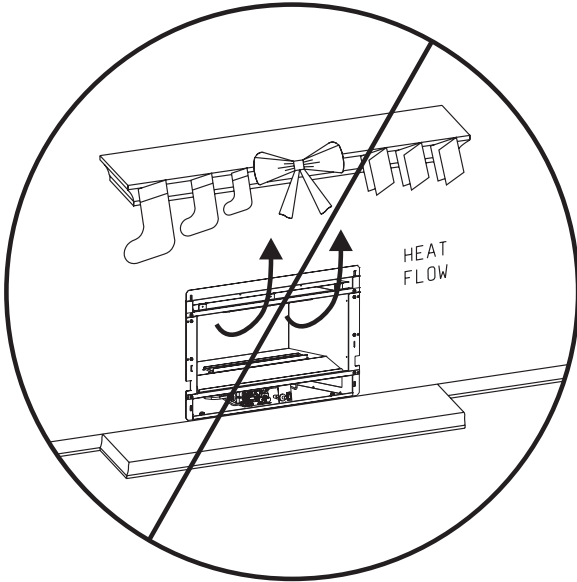

Figure 15

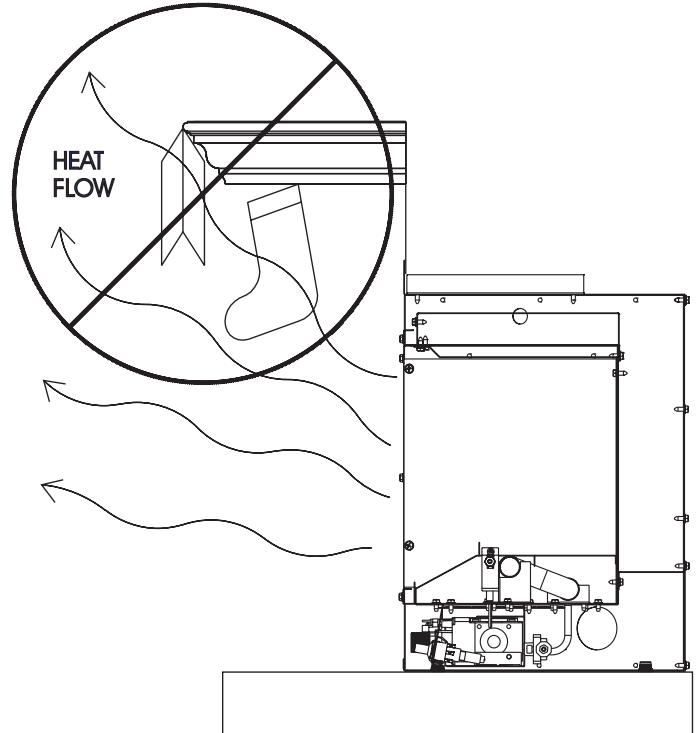

Figure 16

MILLIVOLT ALTERNATE ON/OFF SWITCH INSTALLATION

WIRING THE FIREPLACE

⚠ CAUTION

Disconnect remote controls if you are absent for extended time periods. This will prevent accidental fireplace operation.

Installation of Alternate Surround Panel ON/OFF Switch

An ON/OFF switch and wire assembly is provided. They are included in the instruction packet.

Do not cut wire or insulation on metal edges.

Contemporary Surrounds

1. Find the coiled low voltage wire assembly and ON/OFF switch located in the instruction packet.
2. **Millivolt Valve** - Attach the flag terminal ends to the "TH/TP" and "TH" terminals on the front terminal block of the gas valve. **See Figure 18.**
"IP" Valve - Locate the two 5-1/2-inch long black wires connected to the ON/OFF switch. Disconnect these two black wires at the green and white wire connections. Attach the flag terminals (the low voltage wire assembly found in the Instruction Packet) to the green and white wire connections. **See Figures 19 and 20.**
3. Run the low voltage alternate switch wires to the right of the surround panel. Use the top knockout location. Then secure the wires with wire clips provided. **See Figure 17.**
4. The included ON/OFF switch may be installed into the right-hand corner of the surround. Using a screwdriver, remove the knockout and snap the switch into place. Attach the two wire terminals from the wire assembly coming from the valve terminals.

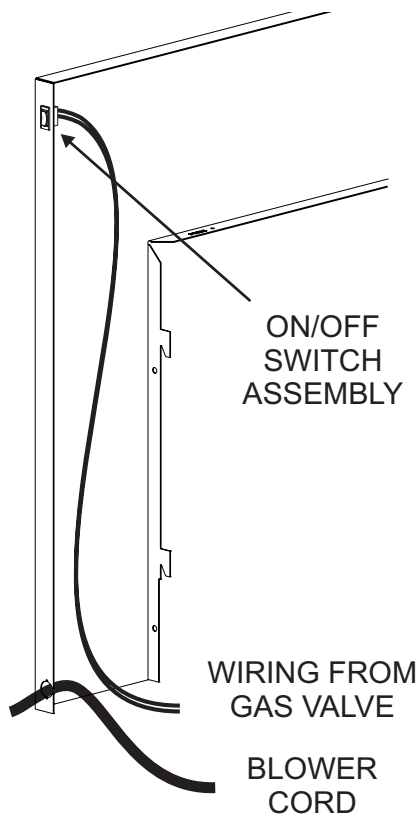

5. Connect the low voltage wires from the gas valve to the ON/OFF switch.
 - a. For millivolt valve connections, **See Figure 18.**
 - b. For IP valve connections, locate the green and white wires from the control module, then connect the switch wire flag terminals to the green and white wire terminals. **See Figures 19 and 20.**

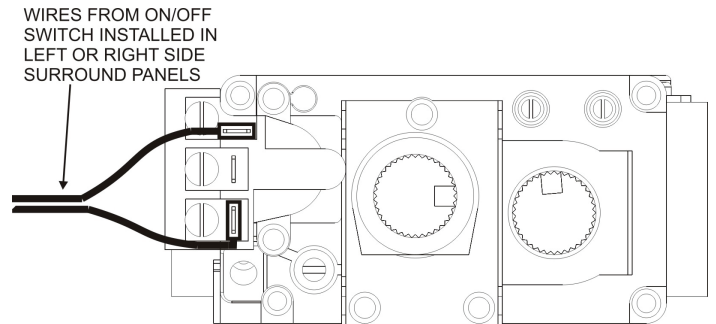

NOTE: TO OPERATE INSERT WITH SIDE PANEL ON/OFF SWITCH, BE SURE TO PLACE THE MAIN SWITCH (TO THE RIGHT SIDE OF GAS VALVE) TO "OFF" POSITION.

Figure 18

REMOVE BLACK SWITCH WIRES

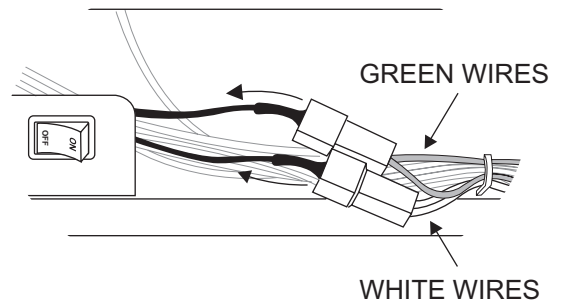

Figure 19

ATTACH EXTENSION SWITCH WIRES

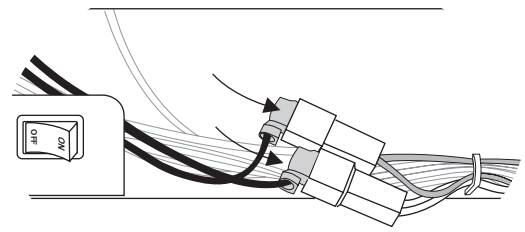

Figure 20

6. Attach the surround assembly to the insert.

DECORATIVE ACCESSORY INSTALLATION

⚠ WARNING

Failure to position the parts in accordance with the diagrams and instructions below or failure to use only parts specifically approved for use with this heater may result in property damage or personal injury.

NOTICE: The Loft series burners may be operated with or without the Decorative accessory options. Follow the directions below should you choose to enhance your Loft burner with any one of the available decorative options.

DECORATIVE GLASS ACCESSORY PLACEMENT

The Decorative Glass options are available in various colors and package sizes. Choose the size appropriate for your fireplace:

VFLC20IN will accept 1 sq. ft. of decorative glass or rock.

VFLC28IN will accept 1-1/2 sq. ft. of decorative glass or rock.

See Page 7.

⚠ CAUTION

Use gloves and eye protection while applying the decorative glass.

INSTALLATION

1. Application of the Decorative Glass should only be performed after the Loft burner has been fully installed, secured and tested for leaks. If operating the burner with a Remote Control, make sure all batteries are installed and that the Loft burner operates with the remote correctly.
3. To install the Decorative Glass, cut off a corner of the plastic bag and proceed to apply the glass to the rear shelf on the Loft burner (area behind the burner). Apply only enough glass to cover the black metal surfaces. Do not allow the glass to fall around the burner tube. **See Figures 21 and 22.** Apply the remaining decorative glass to the front sloped surface of the Top Cover. Start by placing the glass along the front edge of the top cover, then gradually place the glass up the sloped top until completely covered. Do not allow the glass to fall around the burner tube. **See Figure 23.**

⚠ CAUTION

Never place glass on top of or next to the burner.

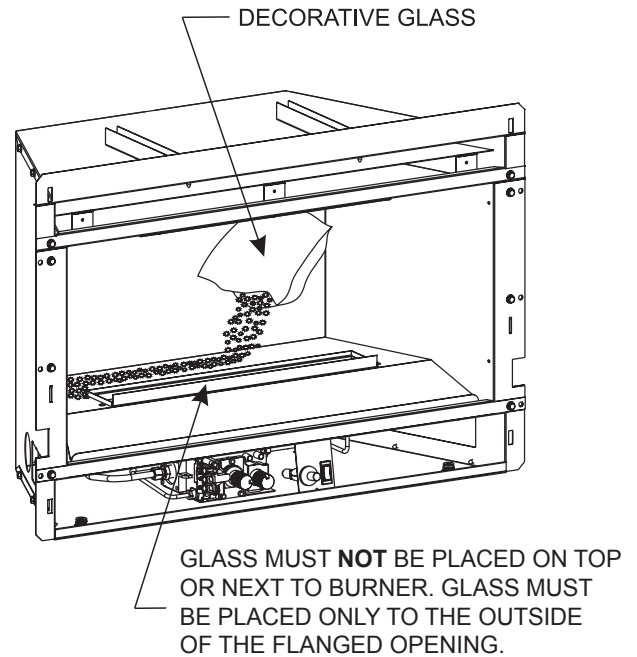

Figure 21

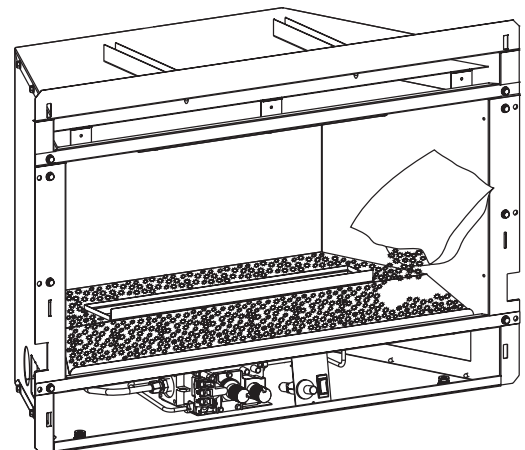

Figure 22

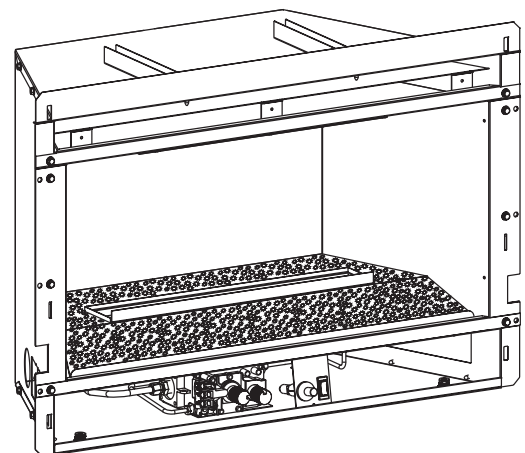

Figure 23

10,000 BTU MILLIVOLT CONTROL VALVE LIGHTING INSTRUCTIONS



FOR YOUR SAFETY READ BEFORE LIGHTING

⚠ WARNING

If you do not follow these instructions exactly, a fire or explosion may result causing property damage, personal injury or loss of life.

- A. This appliance has a pilot which must be lighted by hand. When lighting the pilot, follow these instructions exactly.
- B. **BEFORE LIGHTING** smell all around the appliance area for gas. Be sure to smell next to the floor because some gas is heavier than air and will settle on the floor.
- WHAT TO DO IF YOU SMELL GAS**
- Do not try to light any appliance.
 - Do not touch any electrical switch; Do not use any phone in your building.
 - Immediately call your gas supplier from a neighbor's phone. Follow the gas supplier's instructions.
 - If you cannot reach your gas supplier, call the fire department.
- C. Use only your hand to push in or turn the gas control knob. Never use tools. If the knob will not push in or turn by hand, don't try to repair it; call a qualified service technician. Force or attempted repair may result in a fire or explosion.
- D. Do not use this appliance if any part has been under water. Immediately call a qualified service technician to inspect the appliance and to replace any part of the control system and any gas control which has been under water.

LIGHTING INSTRUCTIONS

1. STOP! Read the safety information above.
2. Remove barrier assembly.
3. Set REMOTE/OFF/ON switch to "OFF."
4. Turn off all electric power to the appliance (if applicable).
5. Push in gas control knob slightly and turn clockwise  to "OFF."
6. Wait ten (10) minutes to clear out any gas. Then smell for gas, including near the floor. If you smell gas, STOP! Follow "B" in the safety information above. If you do not smell gas, go to the next step.
7. Find pilot - Follow metal tube from gas control. The pilot is located next to the burner, near the right side.
8. Turn gas control knob counterclockwise  to "PILOT."
9. Push in control knob all the way and hold in. Repeatedly push the Piezo Ignitor Button until the pilot is lit. Continue to hold the control knob in for about one (1) minute after the pilot is lit. Release knob, and it will pop back up. Pilot should remain lit. If it goes out, repeat steps 5 through 9.
 - If knob does not pop up when released, STOP and IMMEDIATELY call a qualified service technician or gas supplier.
 - If the pilot will not stay lit after several tries, turn the gas control knob to "OFF" and call your service technician or gas supplier.
10. Turn gas control knob counterclockwise  to "ON."
11. Set REMOTE/OFF/ON switch to desired setting.
12. Turn on all electric power to the appliance (if applicable).
13. Re-install the barrier assembly.

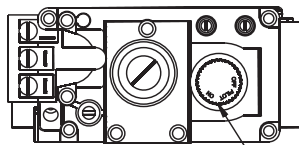

GAS CONTROL KNOB—SHOWN IN "OFF" POSITION.

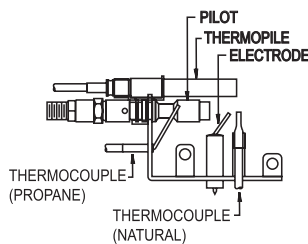
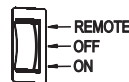

TO TURN OFF GAS TO APPLIANCE

1. Open bottom louver assembly (if applicable).
2. Set REMOTE/OFF/ON switch to OFF.
3. Turn off all electric power to the appliance if service is to be performed (if applicable).
4. Push in gas control knob slightly and turn clockwise  to "OFF." Do not force.
5. Re-install the barrier assembly.

MILLIVOLT CONTROL VALVE LIGHTING INSTRUCTIONS



FOR YOUR SAFETY READ BEFORE LIGHTING

⚠ WARNING

If you do not follow these instructions exactly, a fire or explosion may result causing property damage, personal injury or loss of life.

- A. This appliance has a pilot which must be lit by hand. When lighting the pilot, follow these instructions exactly.
- B. **BEFORE LIGHTING** smell all around the appliance area for gas. Be sure to smell next to the floor because some gas is heavier than air and will settle on the floor.
- WHAT TO DO IF YOU SMELL GAS**
- Do not try to light any appliance.
 - Do not touch any electrical switch; Do not use any phone in your building.
 - Immediately call your gas supplier from a neighbor's phone. Follow the gas supplier's instructions.
 - If you cannot reach your gas supplier, call the fire department.
- C. Use only your hand to push in or turn the gas control knob. Never use tools. If the knob will not push in or turn by hand, don't try to repair it; call a qualified service technician. Force or attempted repair may result in a fire or explosion.
- D. Do not use this appliance if any part has been under water. Immediately call a qualified service technician to inspect the appliance and to replace any part of the control system and any gas control which has been under water.

LIGHTING INSTRUCTIONS

1. STOP! Read the safety information label.
2. Remove barrier assembly.
3. Set REMOTE/OFF/ON switch to "OFF."
4. Turn off all electric power to the appliance (if applicable).
5. Push in gas control knob slightly and turn clockwise  to "OFF." NOTE: Knob cannot be turned from "PILOT" to "OFF" unless knob is pushed in slightly. Do not force.
6. Wait ten (10) minutes to clear out any gas. Then smell for gas, including near the floor. If you smell gas, STOP! Follow "B" in the safety information above. If you do not smell gas, go to the next step.
7. Find pilot - Follow metal tube from gas control. The pilot is behind the burner on the right side.
8. Turn gas control knob counterclockwise  to "PILOT."
9. Push in control knob all the way and hold in. Repeatedly push the Piezo Ignitor Button until the pilot is lit. Continue to hold the control knob in for about one (1) minute after the pilot is lit. Release knob, and it will pop back up. Pilot should remain lit. If it goes out, repeat steps 5 through 9.
 - If knob does not pop up when released, STOP and IMMEDIATELY call a qualified service technician or gas supplier.
 - If the pilot will not stay lit after several tries, turn the gas control knob to "OFF" and call your service technician or gas supplier.
10. Turn gas control knob counterclockwise  to "ON."
11. Set REMOTE/OFF/ON switch to desired setting.
12. Turn on all electric power to the appliance (if applicable).
13. Re-install the barrier assembly.

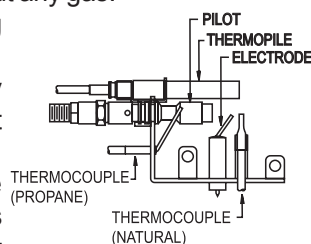
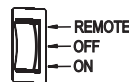
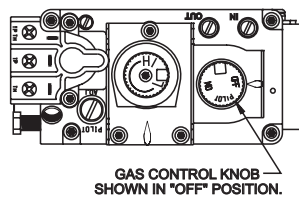

TO TURN OFF GAS TO APPLIANCE

1. Remove barrier assembly.
2. Set REMOTE/OFF/ON switch to "OFF."
3. Turn off all electric power to the appliance if service is to be performed (if applicable).
4. Push in gas control knob slightly and turn clockwise  to "OFF." Do not force.
5. Re-install the barrier assembly.

MILLIVOLT CONTROL VALVE WIRING

Label all wires prior to disconnection when servicing controls. Wiring errors can cause improper and dangerous operation. Verify proper operation after servicing.

Millivolt thermopile is self powered, gas valve does not require 110 volts. Maximum length of 20 feet of 16 AWG to conductor wires is to be used with all optional switches.

Use the two leads (Red and Green) to attach optional components.

Check 750 Millivolt System Operation

Millivolt system and all individual components may be checked with a millivolt meter 0-1000 MV range.

Remote Receiver

Use the following steps to place the remote receiver adjacent to the gas valve.

Attention: The remote receiver bracket is not used in this installation.

1. The remote receiver can not be placed behind the gas valve and burner assembly.
2. When facing the appliance, the remote receiver must be placed to the right of the gas valve.

Install remote control receiver behind bottom louver.

Refer to remote control installation and operating instructions for more details on remote control.

WIRING DIAGRAM

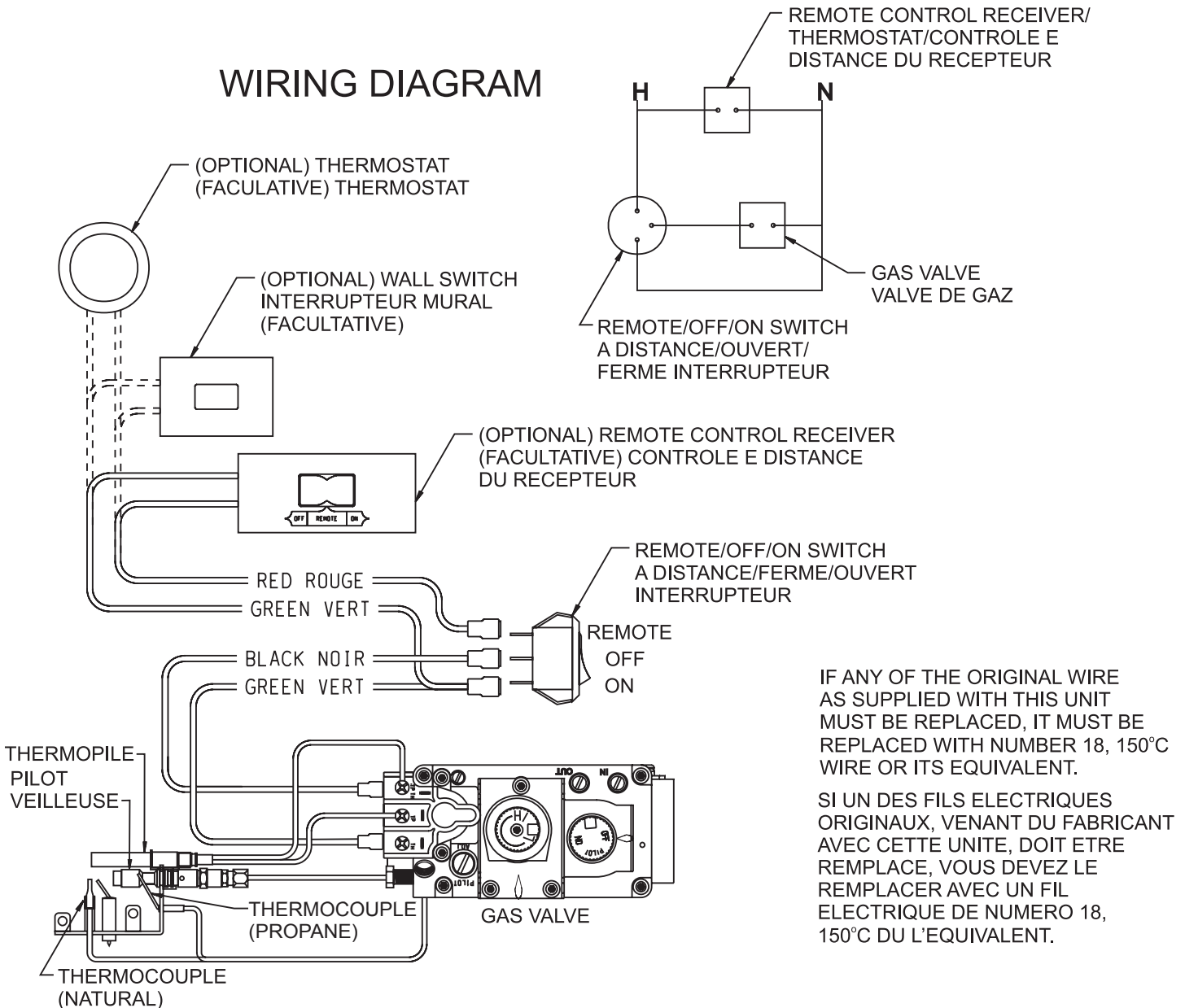

IF ANY OF THE ORIGINAL WIRE AS SUPPLIED WITH THIS UNIT MUST BE REPLACED, IT MUST BE REPLACED WITH NUMBER 18, 150°C WIRE OR ITS EQUIVALENT.

SI UN DES FILS ELECTRIQUES ORIGINAUX, VENANT DU FABRICANT AVEC CETTE UNITE, DOIT ETRE REMPLACE, VOUS DEVEZ LE REMPLACER AVEC UN FIL ELECTRIQUE DE NUMERO 18, 150°C DU L'EQUIVALENT.

Figure 24

PILOT FLAME CHARACTERISTICS

Figure 25 shows a correct pilot flame pattern. The correct flame will be blue and will extend beyond the thermocouple. The flame will surround the thermocouple just below the tip. A slight yellow flame may occur where the pilot flame and main burner flame meet. **Figure 26** shows an incorrect pilot flame pattern. The incorrect pilot flame is not touching the thermocouple. This will cause the thermocouple to cool. When the thermocouple cools, the heater will shut down.

MILLIVOLT PILOT

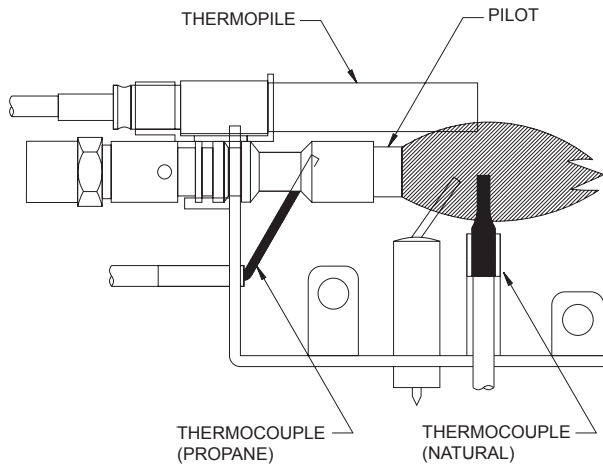

Correct Pilot Flame Pattern
Figure 25

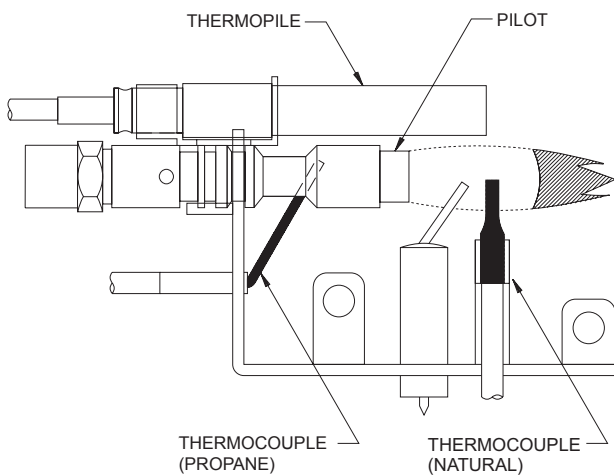

Incorrect Pilot Flame Pattern
Figure 26

If pilot flame pattern is incorrect, as shown in **Figure 26**

- See Troubleshooting, page 27

TROUBLESHOOTING

SYMPTOMS, POSSIBLE CAUSES AND CORRECTIONS

- 1. When ignitor button is pressed, there is no spark at ODS/pilot.**
 - a. Ignitor electrode positioned wrong - Replace pilot.
 - b. Ignitor electrode is broken - Replace pilot.
 - c. Ignitor electrode not connected to ignitor cable - Reconnect ignitor cable.
 - d. Ignitor cable pinched or wet. Keep ignitor cable dry - Free ignitor cable if pinched by any metal or tubing.
 - e. Broken ignitor cable - Replace ignitor cable.
 - f. Bad piezo ignitor - Replace piezo ignitor.
- 2. Appliance produces unwanted odors.**
 - a. Appliance burning vapors from paint, hair spray, glues, etc. - Ventilate room. Stop using odor causing products while heater is running.
 - b. Gas leak - Locate and correct all leaks.
- 3. Appliance shuts off during use. (Pilot and main burner are off.)**
 - a. Not enough fresh air is available for ODS/pilot to operate - Open window and/or door for ventilation.
 - b. Low line pressure - Contact local gas company.
 - c. ODS/pilot is partially clogged - Clean ODS/pilot.
 - d. Defective thermocouple - Replace pilot.
- 4. Appliance shuts off during use. (Pilot stays on.)**
 - a. Low line pressure - Check line pressure to the valve.
 - b. Defective thermopile - Check pilot flame, check wire connections, output should be a minimum of 325 millivolts across. TH/TP and TP terminals with REMOTE/OFF/ON switch off.
- 5. Gas odor even when control knob is in OFF position.**
 - a. Gas leak - Locate and correct all leaks.
 - b. Control valve defective - Replace control valve.
- 6. When ignitor button is pressed, there is spark at ODS/pilot, but no ignition.**
 - a. Gas supply turned off or manual shutoff valve closed - Turn on gas supply or open manual shutoff valve.
 - b. Control knob not in PILOT position - Turn control knob to PILOT position.
 - c. Control knob not pressed in while in PILOT position - Press in control knob while in PILOT position.
 - d. Air in gas lines when installed - Continue holding down control knob. Repeat igniting operation until air is removed.
 - e. ODS/pilot is clogged - Replace ODS/pilot assembly or get it serviced.
 - f. Gas regulator setting is not correct - Replace gas regulator.
- 7. ODS/pilot lights but flame goes out when control knob is released.**
 - a. Control knob not fully pressed in - Press in control knob fully.
 - b. Control knob not pressed in long enough - After ODS/pilot lights, keep control knob pressed in 30 seconds.
 - c. Manual Shutoff valve not fully open - Fully open manual shutoff valve.
 - d. Thermocouple connection loose at control valve - Hand tighten until snug, then tighten 1/4 turn more.
 - e. Pilot flame not touching thermocouple, which allows thermocouple to cool, causing pilot flame to go out. This problem could be caused by either low gas pressure or dirty or partially clogged ODS/pilot - Contact local gas company.
- 8. Burner does not light after ODS/pilot is lit.**
 - a. Burner orifice clogged - Clean burner or replace main burner orifice.
 - b. Burner orifice diameter is too small - Replace burner orifice.
 - c. Inlet gas pressure is too low - Contact qualified service person.
- 9. If burning at main burner orifice occurs (a loud, roaring blow torch noise).**
 - a. You must turn off burner assembly and contact a qualified service person.
 - b. Manifold pressure is too low - Contact local gas company.
 - c. Burner orifice clogged - Clean burner or replace burner orifice.
- 10. Heater produces a whistling noise when main burner is lit.**
 - a. Turning control knob to HIGH position when main burner is cold - Turn control knob to LOW position and let warm up for a minute (does not apply to 10k BTU models)
 - b. Air in gas line - Operate burner until air is removed from line. Have gas line checked by local gas company.
 - c. Dirty or partially clogged burner orifice - Clean burner or replace burner orifice.

If the gas quality is bad, your pilot may not stay lit, the burners may produce soot and the heater may backfire when lit. If the gas quality or pressure is low, contact your local gas supplier immediately.

INTERMITTENT PILOT LIGHTING INSTRUCTIONS

FOR YOUR SAFETY READ BEFORE LIGHTING

⚠ WARNING

If you do not follow these instructions exactly, a fire or explosion may result causing property damage, personal injury or loss of life.

- A. This appliance has a pilot which must be lighted by hand. When lighting the pilot, follow these instructions exactly.
- B. Before lighting smell all around the appliance area for gas. Be sure to smell next to the floor because some gas is heavier than air and will settle on the floor.
- What To Do If You Smell Gas
- Do not try to light any appliance.
 - Do not touch any electrical switch;
 - Do not use any phone in your building.
 - Immediately call your gas supplier from a neighbor's phone. Follow the gas supplier's instructions.
 - If you cannot reach your gas supplier, call the fire department.
- C. Use only your hand to push in or turn the gas control knob. Never use tools. If the knob will not push in or turn by hand, don't try to repair it; call a qualified service technician. Force or attempted repair may result in a fire or explosion.
- D. Do not use this appliance if any part has been under water. Immediately call a qualified service technician to inspect the appliance and to replace any part of the control system and any gas control which has been under water.

LIGHTING INSTRUCTIONS

1. STOP! Read the safety information above.
2. Turn OFF electric power to the appliance.
3. Remove barrier screen assembly or bottom louver if included.
4. Turn gas shut-off counterclockwise ↶ to "On" position.
5. Wait ten (10) minutes to clear out any gas. Then smell for gas, including near the floor. If you smell gas, STOP! Follow "B" in the safety information above on this page. If you do not smell gas, go to the next step.
6. Turn ON electric power to the appliance.
7. Find pilot - Follow metal tube from gas control. The pilot is behind the burner on the right side.
8. Turn main flame to on. If the pilot does not light within 60 seconds, stop and go to Step 5.
9. **NOTE:** There is a CPI/IPI switch behind the right side panel that allows for a continuous standing pilot mode or an intermittent pilot mode. See appliance manual for location of this switch. If the pilot or burner does not stay lit (in the standing pilot mode), stop and immediately call a qualified service technician or gas supplier.
10. If the burner or pilot does not operate properly after several tries, turn the gas shut-off clockwise ↷ to "OFF" and call your service technician or gas supplier.
11. Replace barrier screen assembly or close bottom louver assembly.
12. Operation of the gas valve is controlled by a manual on/off switch or a hand held remote control. Refer to remote instructions for detailed operation information.

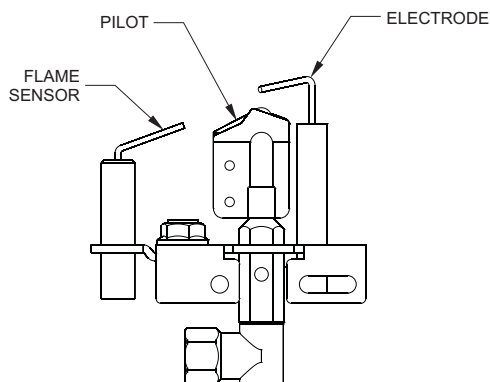

GAS SHUT-OFF VALVE

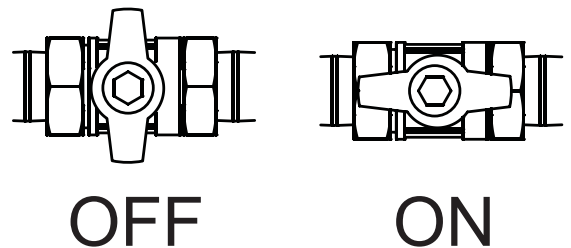

TO TURN OFF GAS TO APPLIANCE

1. Set REMOTE/OFF/ON switch to OFF.
2. Turn off all electric power to the appliance if service is to be performed (if applicable).
3. Lower bottom louver assembly.
4. Push in gas control knob slightly and turn clockwise ↷ to "OFF." Do not force.
5. Close bottom louver assembly.

OPERATION INSTRUCTIONS/FLAME APPEARANCE

Flames from the pilot and the main flame should be visually checked.

In normal operation at full rate after 10 to 15 minutes, the flame appearance should be a line of yellow tipped flames.

NOTICE: All flames will be random by design, flame height will go up and down.

Avoid any drafts that alter burner flame patterns. Do not allow fans to blow directly into fireplace. Do not place a blower inside the burner area of the firebox. Ceiling fans may create drafts that alter flame patterns. Sooting and improper burning will result.

During manufacturing, fabricating and shipping, various components of this appliance are treated with certain oils, films or bonding agents. These chemicals are not harmful, but may produce annoying smoke and smells as they are burned off during the initial operation of the appliance, possibly causing headaches or eye or lung irritation. This is a normal and temporary occurrence.

The initial break-in operation should last 2-3 hours with the burner at the highest setting. Provide maximum ventilation by opening windows or doors to allow odors to dissipate. Any odors remaining after this initial break-in will be slight and will disappear with continued use.

PERIODIC CLEANING – Refer to parts diagram for location of items discussed below.

- Do not use cleaning fluid to clean any part of heater.
- Remove loose particles and dust from the burner areas and controls.
- Inspect and clean burner air intake hole. Remove lint or particles with brush. Failure to keep air intake hole clean will result in sooting and poor combustion.

ANNUAL CLEANING/INSPECTION – Refer to parts diagram for location of items discussed below.

- Inspect and clean burner air intake hole. Remove lint or particles with vacuum or brush. Failure to keep air intake hole clean will result in sooting and poor combustion.
- Inspect and clean all burner ports.
- Inspect ODS pilot for operation and accumulation of lint at air intake holes.
- Verify flame pattern for proper operation.
- Verify smooth and responsive ignition of main burner.

PILOT FLAME CHARACTERISTICS

INTERMITTANT PILOT

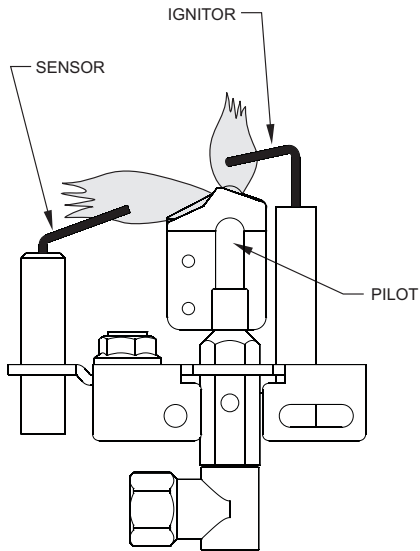

**Correct Pilot Flame Pattern
Figure 27**

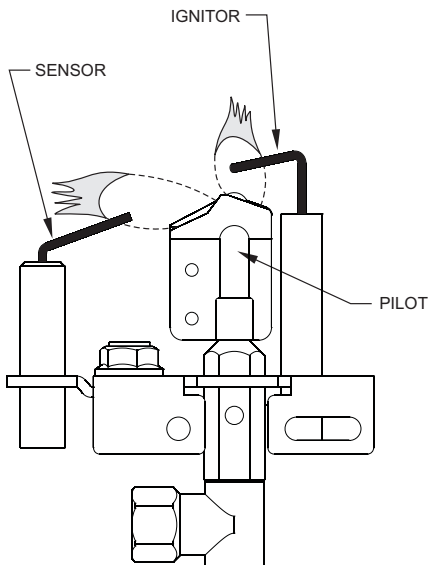

**Incorrect Pilot Flame Pattern
Figure 28**

If pilot flame pattern is incorrect, as shown in **Figure 32**.

- See Troubleshooting, pages 33 through 37.

CLEANING AND PILOT MAINTENANCE

Oxygen Depletion Sensor Pilot - Figures 29 and 30

When the pilot has a large yellow tip flame, clean the Oxygen Depletion Sensor as follows:

1. Clean the ODS pilot by loosening nut B from the pilot tubing. When this procedure is required, grasp nut A with an open end wrench.
2. Blow air pressure through the holes indicated by the arrows. This will blow out foreign materials such as dust, lint and spider webs. Tighten nut B also by grasping nut A.

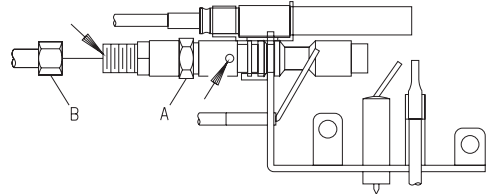

**Millivolt Pilot
Figure 29**

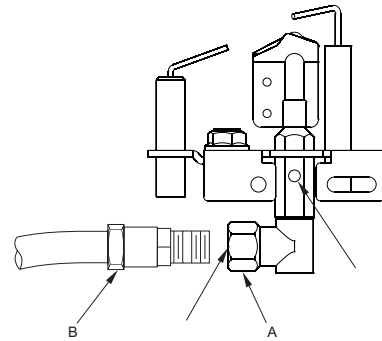

**Intermittant Pilot
Figure 30**

⚠ WARNING

Never use needles, wires, or similar cylindrical objects to clean the pilot to avoid damaging the calibrated ruby that controls the gas flow.

IPI ELECTRONIC SYSTEM OPERATING INSTRUCTIONS

5.25 VDC ELECTRONIC CONTROL VALVE

The electronic control valve system includes the ability to switch the pilot from a standing pilot mode to an intermittent pilot mode.

- **IPI Mode** - In the Intermittent Pilot mode, when the unit is turned ON, it will cause spark to the pilot, light the pilot, then allow the burner to light. When the unit is turned OFF, both the burner and pilot will be OFF.
- **CPI Mode** - In the Continuous Pilot mode, the pilot remains ON continuously even when the burner is turned OFF.

NOTE: A small toggle switch is located on a bracket that is used to switch from IPI (upward position) to the CPI (downward position). **See Figure 31.**

When the unit is turned to ON, the electrical current will energize a spark to the pilot igniter. Once the pilot sensor heats up (after a few seconds), the valve will be energized, allowing gas to flow to the burner.

1. Follow the SAFETY and LIGHTING INSTRUCTIONS for Intermittent Pilot controls found in this manual, and on labels found in the control compartment located in the lower cavity of the appliance.
2. During the operating season (or in power outage periods), it is recommended that the pilot remain in the CPI (standing pilot mode) to reduce cold start issues, and/or conserve battery backup power during a power outage.
3. The gas valve has inlet and outlet pressure taps as shown in **Figure 31**. Refer to page 19 for gas pressure requirements.

NOTE: The gas control has a manual HI/LO flame adjustment knob (regulator) that allows you to increase or decrease the height of the burner flame. **See Figure 31.** Rotate the HI/LO knob counterclockwise to "HI" to increase the flame height, and clockwise to "LO" to decrease the flame height.

OPTIONAL REMOTE CONTROLS

Optional remote controls are available for use with this appliance. To connect the remote receiver to the appliance, first disconnect the ON/OFF switch wires from the white and green wire connectors and connect the wires from the remote receiver to the green and white wire connectors.

Follow the instructions included with the remote control for programming and other operational information.

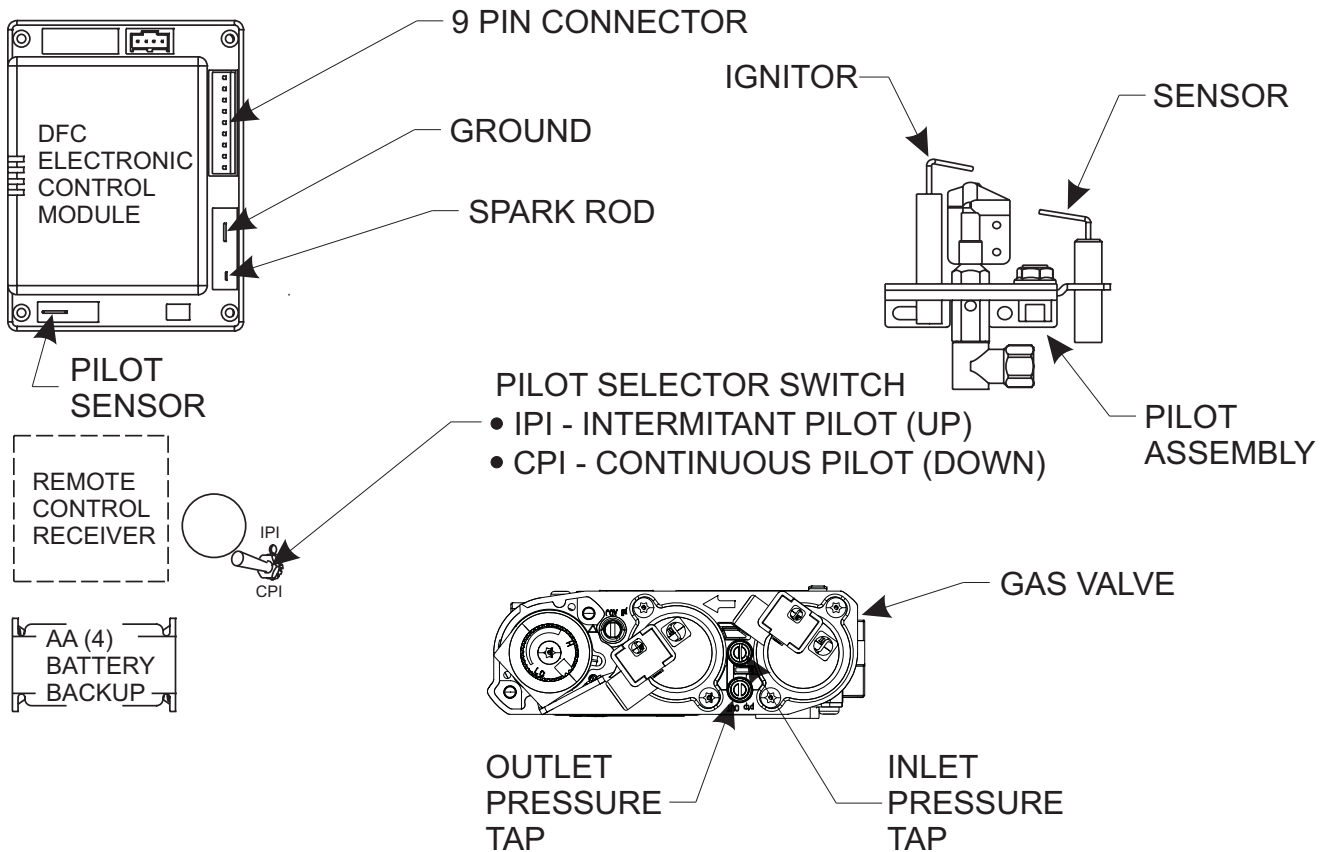

Figure 31

IPI ELECTRONIC SYSTEM WIRING DIAGRAM

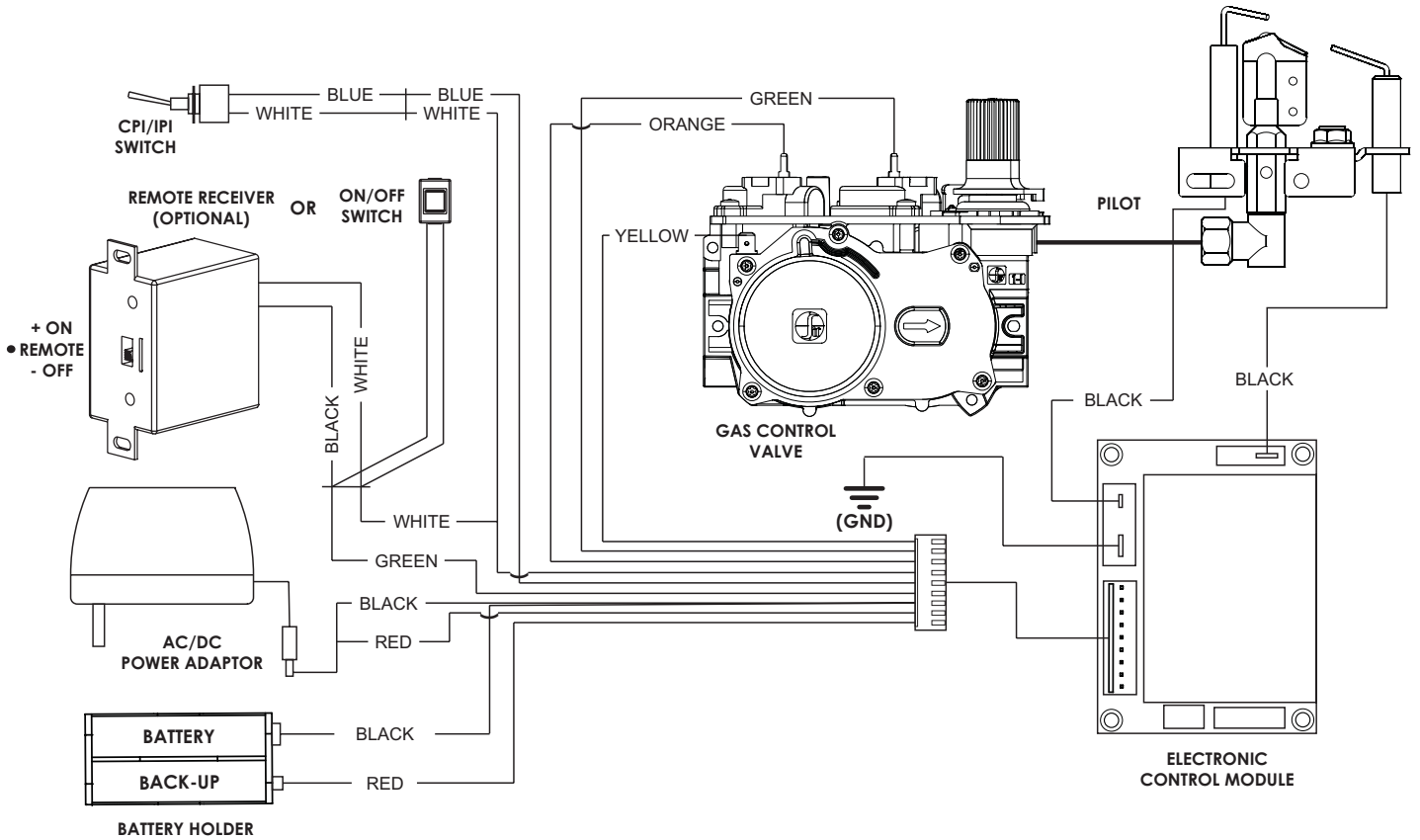

Figure 32

If any of the original wire as supplied with this unit must be replaced, it must be replaced with equivalent gauge and temperature rated wire.

INTERMITTENT CONTROL SYSTEM TROUBLESHOOTING

Brief Description of the Components

The gas valve is equipped with a manual HI/LO knob to allow for manual modulation of the gas outlet pressure. The manual HI/LO knob can be replaced by an Empire Comfort Systems Variable Remote Kit.

WARNING

This appliance is equipped for (Natural or Propane Gas). Field conversion is not permitted.

The Digital Fireplace Control (DFC) is an automatic gas ignition system based on a single microcontroller core. This control manages all functions related to ignition, flame sensing and supervision for atmospheric applications.

The DFC can be set to provide continuous or intermittent ignition control sequences and flame monitoring with safety shutdown in case of failure.

The DFC is set up as a stand alone (AC powered system with battery back up. See Lighting Instructions and Wiring Diagram.

Troubleshooting

Before proceeding with the procedures in the following troubleshooting table, verify that the power supply (AC/DC adapter) is present and that the batteries inside the receiver and/or optional battery pack are fresh and installed with correct polarity.

Make sure all the connections between the wire harnesses and system components are proper and positive.

Verify that the static inlet pressure meets the manufacturer's recommended inlet pressure. If necessary adjust the line pressure regulator.

If the recommended actions for the following troubleshooting chart do not help to address the problem consider replacing wiring harnesses.

WARNING

Any actions performed on the gas valve must be performed in accordance with this instruction manual. Likewise, any actions performed on the DFC or other system components must be done in accordance with the individual component instructions.

Replacement of components must be performed in accordance with this instructions manual.

INTERMITTENT CONTROL SYSTEM TROUBLESHOOTING

PROBLEM OBSERVED	POSSIBLE CAUSE	CORRECTIVE MEASURE
Gas odor during setup	Gas Leak	What To Do If You Smell Gas • Do not try to light any appliance. • Do not touch any electrical switch; • Do not use any phone in your building. • Immediately call your gas supplier from a neighbor's phone. Follow the gas supplier's instructions. • If you cannot reach your gas supplier, call the fire department.
Gas odor before first ignition		
Fireplace is "on" but no flame and pilot is not trying to light	Loose gas line connections	Check connections with leak detecting solution
	Loose electrical connections	Check connections with wiring diagram
	(Optional) Receiver batteries bad	Install new batteries
	(Optional) Receiver not sync with remote	Sync receiver with remote. See page ____.
	Gas Line Valve turned "off"	Turn shutoff valve to "open" position
	Control module in "lockout"	Turn fireplace "off" for 2 minutes and then back "on"
	Battery voltage low	Check voltage. Replace batteries if low.
Pilot will not ignite, or will not stay lit	Pilot igniter/sensor is dirty	Clean flame sensor and pilot igniter. See maintenance page ____
	Pilot not grounded well	Check ground connections
	Sensor Wire loose	Check sensor wire terminals
	Pilot gas pressure incorrect	Adjust gas pressure
	Pilot Gas Line bent or kinked	Replace pilot tube
	Faulty pilot, Sensor bent	Replace Pilot
	Faulty valve	Replace Valve
Pilot continues to spark when pilot is lit.	Battery voltage low	Check voltage. Replace batteries if low.
	Not enough gas to pilot	Wait for pilot flame to strengthen
	Low Gas Pressure	Check pressures. See page ____
	Pilot igniter/sensor is dirty	Clean pilot. See maintenance page ____
	Pilot not grounded well	Check ground connections
	Draft in firebox	DV: vent restrictor not installed VF: redirect draft from room or wall
	Pilot sensor has been bent	Replace pilot
Burner takes too long to fully light	Low gas pressure	Check gas supply pressure
	Clogged or dirty carryover/burner ports	Clean ports
	Blocked orifice	Check orifice opening
	Faulty valve	Replace valve
Burner does not light but pilot remains on	Loose electrical connections	Check connections with wiring diagram
	Low gas pressure	Check gas supply pressure
	Clogged or dirty burner ports	Clean burner ports
	Blocked orifice	Check orifice opening
	Loose wire connections	Check valve/control module connections
	(Optional) Receiver not sync with remote	Sync receiver with remote. See page ____.
	(if optional remote) battery too low	Change batteries
	(if optional remote) remote not controlling burner	Re-learn remote box and handheld remote
	Faulty pilot	Replace pilot
	Faulty valve	Replace valve

INTERMITTENT CONTROL SYSTEM TROUBLESHOOTING

PROBLEM OBSERVED	POSSIBLE CAUSE	CORRECTIVE MEASURE
Burner lights but does not stay lit while pilot remains on	Low gas pressure	Check gas supply pressure
	Loose sensor wire	Check wire connection
	Valve not grounded well	Check ground connections
	Clogged or dirty burner ports	Clean burner ports
	(For fireplace equipped with optional thermostat or thermostat remote) Room temperature is higher than thermostat setting	Move (optional) remote away from fireplace Set higher temperature on (Optional) remote/ thermostat
	(Optional) Remote control batteries failing	Replace batteries in remote transmitter and receiver
	Faulty pilot or thermocouple (millivolts)	Replace pilot
	Faulty valve	Replace valve
Burner & pilot light but will not stay lit	Flame sensor dirty	Clean pilot sensor
	Low gas pressure	Check gas supply pressure
	Not enough fresh air for pilot	Open door or window - ventilate
	Clogged or dirty burner ports	Clean burner ports
	(For fireplace equipped with optional thermostat or thermostat remote) Room temperature is higher than thermostat setting	Move (optional) remote away from fireplace Set higher temperature on (Optional) remote/ thermostat
	(Optional) Remote control batteries failing	Replace batteries in remote transmitter and receiver
	Faulty pilot or thermocouple	Replace pilot
Incorrect burner flame	Incorrect gas supply or pressure	Check gas supply pressure
	Blocked orifice	Check orifice opening
	Clogged or dirty burner ports	Clean burner ports
	Faulty valve	Replace valve
	High altitude	Adjust orifice size for altitude or pressure
Backfire of burner	Clogged or dirty burner ports	Clean burner ports
	Blocked orifice	Check orifice opening
	High/Low gas pressure	Check gas supply pressure
Appliance produces unwanted odors	Initial burn-off of manufacturing chemicals	Ventilate room until odor stops
	Vapors from paint, candles, air fresheners, hairspray, glue, etc.	Ventilate room until odor stops. Do not use paint, candles, air fresheners, hairspray, glue, etc around fireplace
Whistle noise from appliance	Check gas pressure	Adjust gas pressure to recommended setting.
	Air in gas line	Bleed lines
	Flex line pinched or too small diameter line	Replace pinched flexline, replace gas feed line with larger diameter, or non-whistle gas flexline (sold separately)

INTERMITTENT CONTROL SYSTEM TROUBLESHOOTING

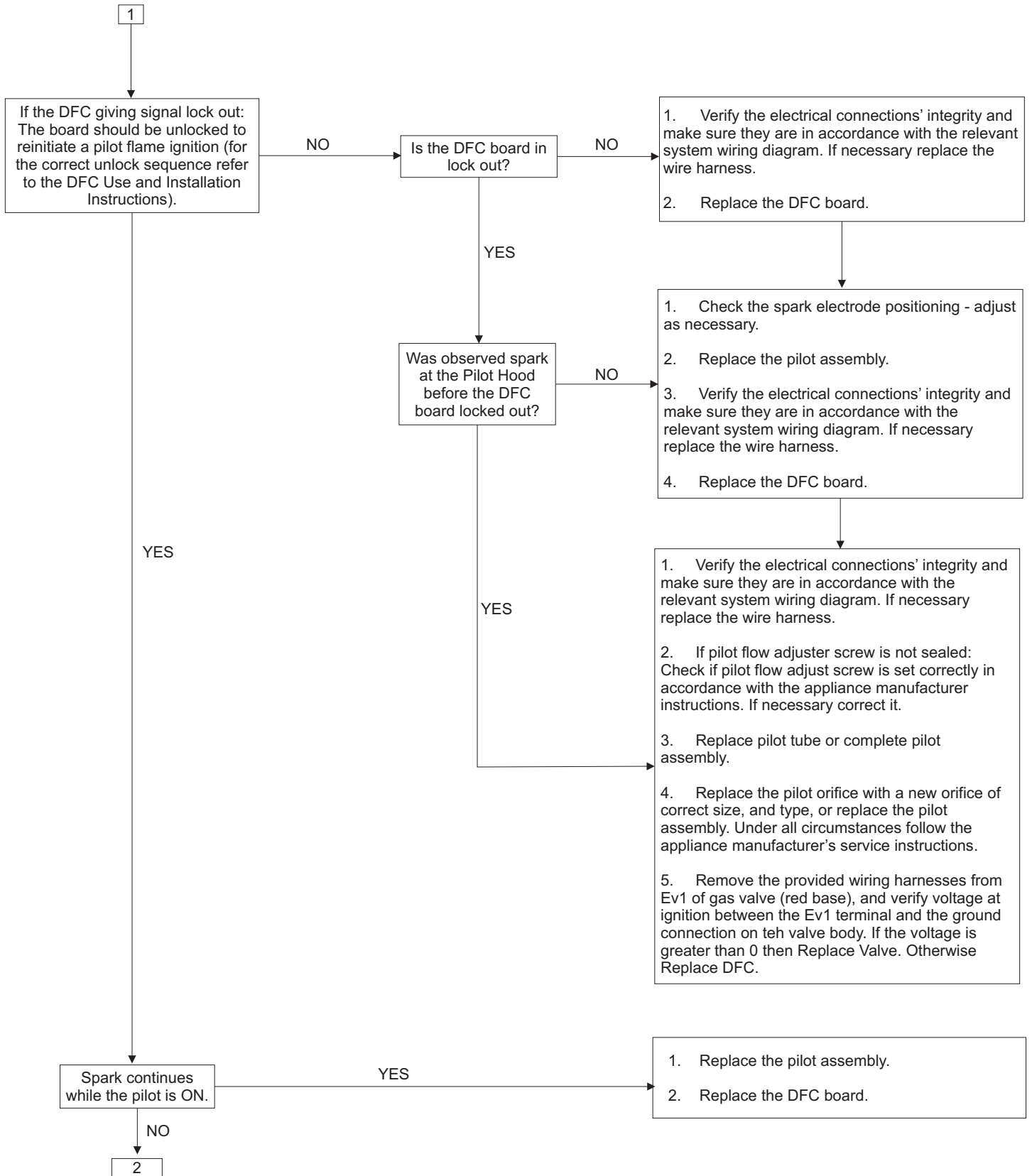

INTERMITTENT CONTROL SYSTEM TROUBLESHOOTING

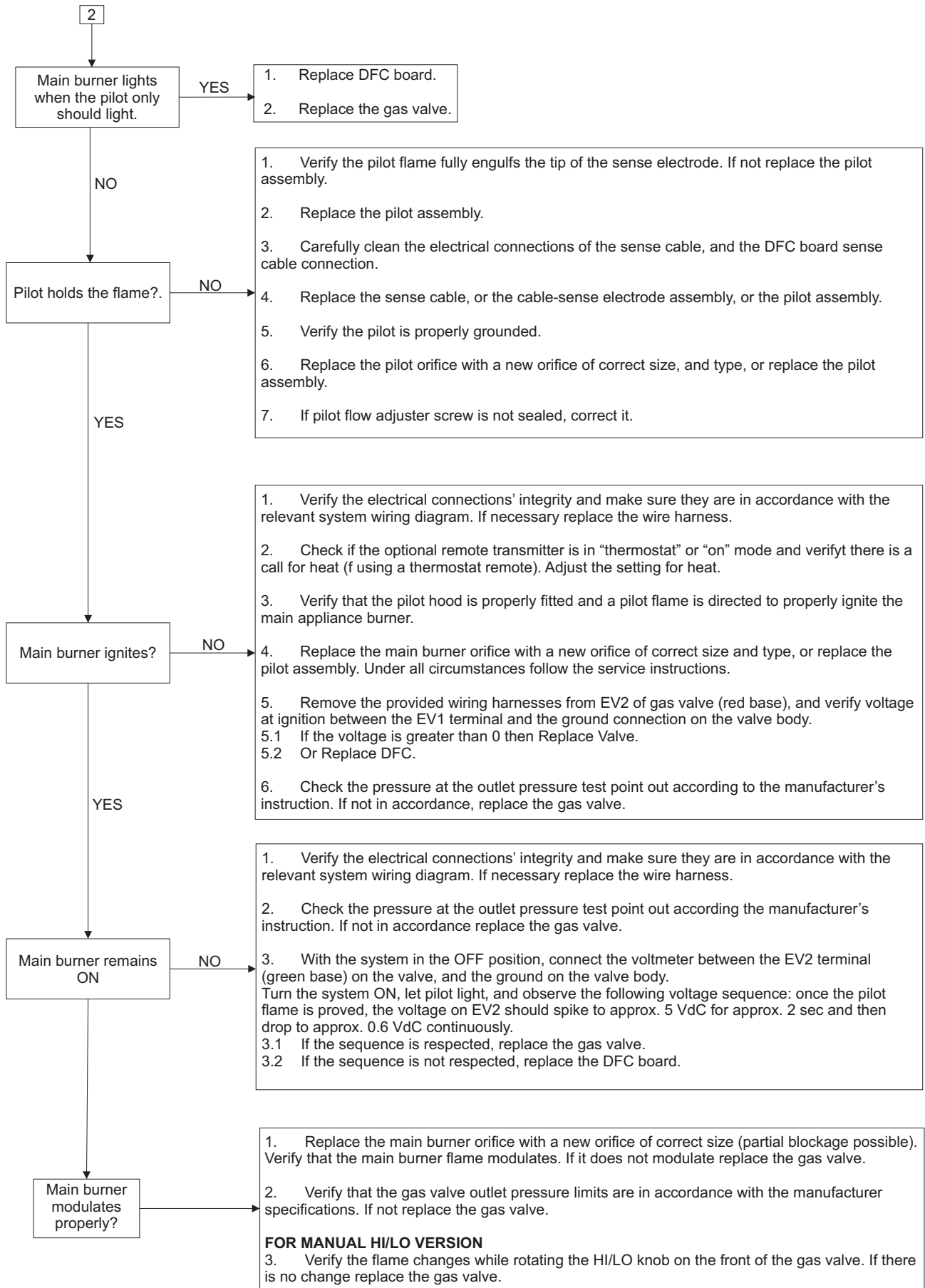

VFLC(20,28)IN PARTS LIST

INDEX NUMBER	MODELS					DESCRIPTION
	VFLC10IN32	VFLC20IN32	VFLC28IN32	VFLC20IN72	VFLC28IN72	
0	-	-	-	-	-	INSERT PAINTED ASSY
1	39769	39769	39770	39769	39770	BAFFLE, FLUE
2	27406	27406	27571	27406	27571	BURNER ASSEMBLY COVER
3	39763	39763	40335	39764	39768	FIREBOX BOTTOM - NATURAL
3	39763	39763	40335	39764	39768	FIREBOX BOTTOM - PROPANE
4	31669	31669	31669	31669	31669	BLOWER SHIELD
5	27085	27085	27085	27085	27085	BURNER SUPPORT
6	R7624	R7624	R7624	R7624	R7624	AIR SHUTTER
7	R7572	R7572	R7572	R7572	R7572	JAMB NUT
8	27086	27086	27086	27086	27086	BURNER END SUPPORT
9	P214 (#53)	P288 (2.10MM)	P257 (#40)	P288 (2.10MM)	P257 (#40)	ORIFICE - NATURAL
9	P193 (#64)	P182 (#55)	P258 (1.55MM)	P182 (#55)	P258 (1.55MM)	ORIFICE - PROPANE
10	P212	P212	P212	P212	P212	FITTING, ORIFICE
11	R10477	R10410	R10734	R10410	R10734	BURNER TUBE
12	R3624	R3624	R3624	R11328 - 2019	R11328 - 2019	PILOT ASSY (NATURAL)
12	R3623	R3623	R3623	R11327 - 2019	R11327 - 2019	PILOT ASSY (PROPANE)
13	27147	27147	26165	31284	31284	TUBING ASSEMBLY - INLET
14	27093	27093	27093	31286	31285	TUBING ASSY, REGULATOR TO PILOT
15	R7063	R7063	R7063	R7063	R7063	PILOT REGULATOR (NATURAL)
16	27094	27094	27094	31285	31286	TUBING ASSY, REGULATOR TO VALVE
17	27092	27092	27092	31287	31287	TUBING ASSEMBLY - PILOT (PROPANE)
18	26161	26161	26161	29400	29400	VALVE BRACKET
19	R9368	R3626	R3626	R11125	R11125	VALVE, NATURAL
19	R9369	R3625	R3625	R11126	R11126	VALVE, PROPANE
20	-	-	-	R1978	R1978	PILOT TUBE FITTING
22	26162	26162	26162	-	-	PIEZO BRACKET
23	R3436	R3436	R3436	-	-	SWITCH, REMOTE OFF/ON
24	R9760	R9760	R9760	-	-	IGNITOR, PIEZO
25	39767	39767	28039	39765	31252	PILOT BRACKET - NATURAL
25	39767	39767	28039	39766	31252	PILOT BRACKET - PROPANE
26	-	-	-	R11127	R11127	DFC CONTROL BOARD
27	-	-	-	R11128	R11128	7.0 VDC AC ADAPTER
28	-	-	-	R11122	R11122	BATTERY HOLDER
29	-	-	-	R11123	R11123	WIRE HARNESS, PROFLAME DFC
30	R2423	R2423	R2423	R2423	R2423	CONNECTOR, MALE
31	R7591	R7591	R7591	R7591	R7591	FLEXLINE 3/8" X 12
32	39380	39380	39777	39380	39777	BARRIER SCREEN ASSEMBLY

VFLC(20,28)IN PARTS VIEW

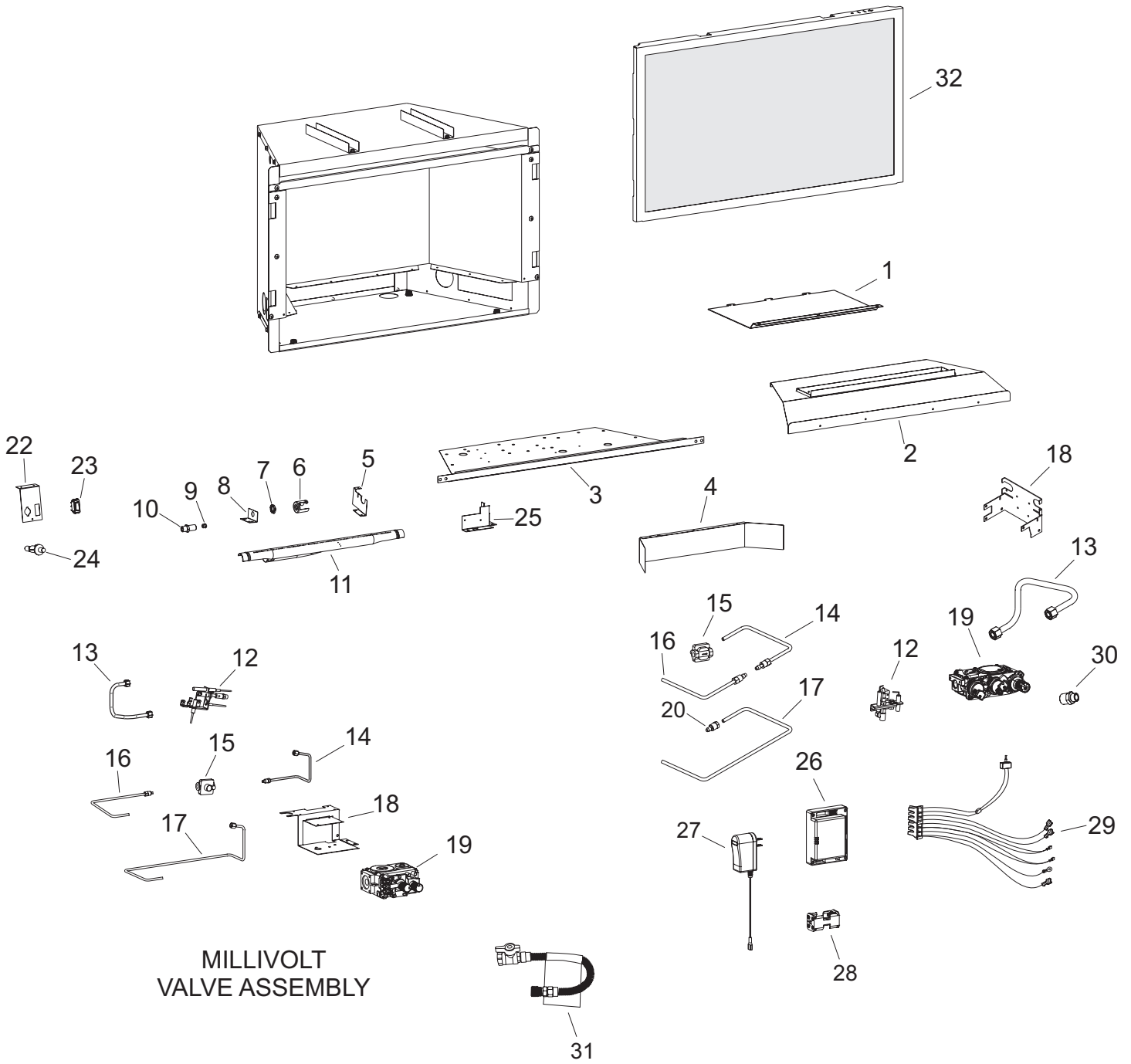

MILLIVOLT
VALVE ASSEMBLY

IP VALVE ASSEMBLY

MASTER PARTS DISTRIBUTOR LIST

To Order Parts Under Warranty, please contact your local Empire dealer. See the dealer locator at www.empirecomfort.com. To provide warranty service, your dealer will need your name and address, purchase date and serial number, and the nature of the problem with the unit.

To Order Parts After the Warranty Period, please contact your dealer or one of the Master Parts Distributors listed below. This list changes from time to time. For the current list, please click on the Master Parts button at www.empirecomfort.com. Please note: Master Parts Distributors are independent businesses that stock the most commonly ordered Original Equipment repair parts for Heaters, Grills, and Fireplaces manufactured by Empire Comfort Systems Inc.

Dey Distributing

1401 Willow Lake Boulevard
Vadnais Heights, MN 55101

Phone: 651-490-9191

Toll Free: 800-397-1339

Website: www.deydistributing.com

Parts: Heater, Hearth and Grills

F. W. Webb Company

200 Locust Street
Hartford, CT 06114

Phone: 860-722-2433

Toll Free: 800-243-9360

Fax: 860-293-0479

Toll Free Fax: 800-274-2004

Websites: www.fwwebb.com & www.victormfg.com

Parts: Heater, Hearth and Grills

East Coast Energy Products

10 East Route 36
West Long Branch, NJ 07764

Phone: 732-870-8809

Toll Free: 800-755-8809

Fax: 732-870-8811

Website: www.eastcoastenergy.com

Parts: Heater, Hearth and Grills

HOW TO ORDER REPAIR PARTS

Parts Not Under Warranty

Parts can be ordered through your Service Person, Dealer, or a Master Parts Distributor. See this page for the Master Parts Distributors list. For best results, the **service person or dealer** should order parts through the distributor. Parts can be shipped directly to the **service person/dealer**.

Warranty Parts

Warranty parts will need a proof of purchase and can be ordered by your Service Person or Dealer. Proof of purchase is **required** for warranty parts.

All parts listed in the Parts List have a Part Number. When ordering parts, first obtain the Model Number and Serial Number from the name plate on your equipment. Then determine the Part Number (**not** the Index Number) and the Description of each part from the following illustration and part list. Be sure to give all this information . . .

Appliance Model Number _____ Part Description _____

Appliance Serial Number _____ Part Number _____

Type of Gas (Propane or Natural) _____

Do not order bolts, screws, washers or nuts. They are standard hardware items and can be purchased at any local hardware store.

Shipments contingent upon strikes, fires and all causes beyond our control.

WARRANTY

Empire Comfort Systems Inc. warrants this hearth product to be free from defects at the time of purchase and for the periods specified below. This warranty applies to the original purchaser only and is not transferable. All warranty repairs must be accomplished by a qualified gas appliance technician.

Limited Lifetime Parts Warranty with a Five-Year Limited Labor Warranty – Combustion Chamber and Heat Exchanger

If the combustion chamber or heat exchanger (see parts list) fails because of defective workmanship or material, Empire will repair or replace it at Empire's option.

Within five years from the date of purchase, Empire will pay reasonable labor to have the defective part repaired or replaced at Empire's option.

Limited Five-Year Parts & Labor Warranty – All Other Components (Except Remote Controls, Thermostats, Lights, Accessories and Replacement Parts)

Should any part fail because of defective workmanship or material within five years from the date of purchase, Empire will repair or replace it at Empire's option.

Within five years from the date of purchase, Empire will pay reasonable labor to an authorized dealer to have that defect repaired at Empire's option.

Limited One-Year Parts Warranty – Remote Controls, Thermostats, Lights, Accessories, and Replacement Parts

Should any remote control, thermostat, lighting system, accessory, or replacement part fail because of defective workmanship within one year from the date of purchase, Empire will repair or replace it at Empire's option.

Duties of the Owner

Have the appliance installed by a qualified installer, and operate and maintain it in accordance with the furnished instructions

Provide proof of purchase (receipt) to establish the purchase date, which determines the warranty start date.

Provide ready access to the appliance for service.

What Is Not Covered

Damage caused by misuse or improper installation.

Damage caused by improper maintenance or lack of maintenance.

Claims that do not involve defective workmanship or materials.

Unauthorized service or replacement parts.

Travel, diagnostic costs and freight charges on warranted parts to and from the factory.

Removal and reinstallation cost.

How to Get Service

Provide the dealer with the model number, serial number, type of gas, and proof of purchase. The installing dealer is responsible for providing service and will contact the factory to initiate any warranted parts replacements. Empire will make replacement parts available at the factory. Shipping expenses are not covered.

If, after contacting your Empire dealer, the service received has not been satisfactory, send an e-mail describing the issue and any actions taken to info@empirecomfort.com with "Consumer Relations" in the subject line.

Your Rights under State Law

This warranty gives you specific legal rights, and you may also have other rights, which vary from state to state.



SINCE 1932

Empire Comfort Systems Inc.
Belleville, IL

If you have a general question
about our products, please e-mail
us at info@empirecomfort.com.

If you have a service or repair
question, please contact your dealer.

www.empirecomfort.com