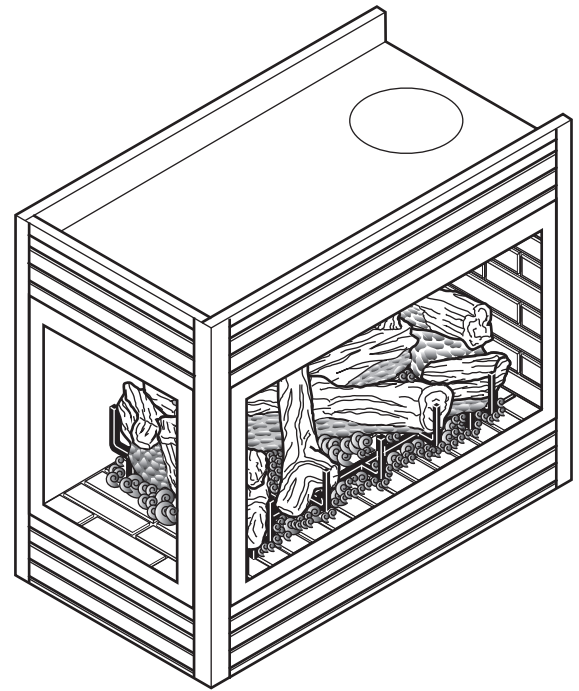




Designer Series Direct Vent Gas Fireplace

Model:
624DV(ST,PF,CR,CL)NVC/PVC,
NEC/PEC



WARNING

IF THE INFORMATION IN THESE INSTRUCTIONS IS NOT FOLLOWED EXACTLY, A FIRE OR EXPLOSION MAY RESULT CAUSING PROPERTY DAMAGE, PERSONAL INJURY OR LOSS OF LIFE.

- Do not store or use gasoline or other flammable vapors and liquids in the vicinity of this or any other appliance.
- **WHAT TO DO IF YOU SMELL GAS**
 - Do not try to light any appliance.
 - Do not touch any electrical switch; do not use any phone in your building.
 - Immediately call your gas supplier from a neighbor's phone. Follow the gas supplier's instructions.
 - If you cannot reach your gas supplier, call the fire department.
- Installation and service must be performed by a qualified installer, service agency or the gas supplier.

WARNING: Improper installation, adjustment, alteration, services or maintenance can cause injury or property damage. Refer to this manual. For assistance or additional information consult a qualified installer, service agency or the gas supplier.

This appliance may be installed in an aftermarket*, permanently located, manufactured home (USA only) or mobile home, where not prohibited by local codes. This appliance is only for use with the type of gas indicated on the rating plate. This appliance is not convertible for use with other gases, unless a certified kit is used.

* Aftermarket: Completion of sale, not for purpose of resale, from the manufacturer.

Installation and Operating Instructions



DUE TO HIGH TEMPERATURES, THE APPLIANCE SHOULD BE LOCATED OUT OF TRAFFIC AND AWAY FROM FURNITURE AND DRAPERIES.

CHILDREN AND ADULTS SHOULD BE ALERTED TO THE HAZARDS OF HIGH SURFACE TEMPERATURE AND SHOULD STAY AWAY TO AVOID BURNS OR CLOTHING IGNITION.

YOUNG CHILDREN SHOULD BE SUPERVISED WHEN THEY ARE IN THE SAME ROOM AS THE APPLIANCE.

CLOTHING OR OTHER FLAMMABLE MATERIAL SHOULD NOT BE PLACED ON OR NEAR THE APPLIANCE.

KEEP THE ROOM AREA CLEAR AND FREE FROM COMBUSTIBLE MATERIALS, GASOLINE, AND OTHER FLAMMABLE VAPORS AND LIQUIDS.

INSTALLER: Leave this manual with the appliance.

CONSUMER: Retain this manual for future reference.

**Thank you and congratulations on your purchase of a
Monessen Fireplace.**

PLEASE READ THE INSTALLATION AND OPERATION INSTRUCTIONS BEFORE USING THE APPLIANCE!

IMPORTANT: Read all instructions and warnings carefully before starting installation.

Failure to follow these instructions may result in a possible fire hazard and will void the warranty.

Important Safety Information	3	Checking Gas Pressure	28
Code Approval	4	Electrical Installation.....	28
Product Features	5	Electrical Wiring	28
High Elevations	5	Remote Wall Switch	29
Gas Pressures	5	Electronic Pilot Ignition	30
Gas Specifications & Orifice Sizes.....	5	Remote Wall Switch	30
Before You Start.....	5	Glass Removal.....	31
Fireplace & Framing Dimensions	6	Log Placement.....	32
Fireplace Dimensions	6	Air Restrictor Adjustment.....	35
Peninsula Fireplace Framing	7	Operating Instructions.....	36
Corner Fireplace Framing	7	What To Do If You Smell Gas.....	36
See Through Fireplace Framing	8	Lighting Pilot for the First Time	36
Clearances	9	Lighting Pilot	37
Installation Information.....	10	Lighting Burner.....	38
Fireplace Location.....	11	To Turn Off Gas.....	38
Secure Fireplace.....	11	Cleaning and Maintenance	39
Optional Top Vent Application.....	12	Venting System	39
Venting Installation.....	13	Cleaning Glass.....	39
Installation Precautions	13	Pilot and Burner Flames	39
Installation Clearances.....	14	Firebox Cleaning.....	39
Installation Planning.....	15	Troubleshooting	40
Installation for Vertical Termination	15	Blower.....	42
Termination Location.....	16	Replacement Parts	43
How to Use the Vent Graph	17	Massachusetts Residents Only.....	50
Rear Wall Vent Installation	18	Warranty	51
Horizontal Termination Configuration	20	Efficiencies.....	52
Below Grade Installation	22		
Vertical Through-the-Roof Installation.....	23		
Installation for Vertical Termination	24		
Flat Ceiling Installation.....	24		
Fireplace Installation.....	26		
Check Gas Type.....	26		
Installing Gas Piping	26		

INSTALLER

Please leave these instructions with the owner.

OWNER

Please retain these instructions for future reference.

WARNING

- **Read this owner’s manual carefully and completely before trying to assemble, operate, or service this fireplace.**
- **Any change to this fireplace or its controls can be dangerous.**
- **Improper installation or use of this fireplace can cause serious injury or death from fire, burns, explosions, electrical shock and carbon monoxide poisoning.**

This fireplace is a vented product. This fireplace must be properly installed by a qualified service person. The glass door must be properly seated and sealed. If this unit is not properly installed by a qualified service person with glass door properly seated and sealed, combustion leakage can occur.

CARBON MONOXIDE POISONING: Early signs of carbon monoxide poisoning are similar to the flu with headaches, dizziness and/or nausea. If you have these signs, the fireplace may not have been installed properly. Get fresh air at once! Have the fireplace inspected and serviced by a qualified service person. Some people are more affected by carbon monoxide than others. These include pregnant women, people with heart or lung disease or anemia, those under the influence of alcohol, and those at high altitudes.

Propane/LP gas and natural gas are both odorless. An odor-making agent is added to each of these gases. The odor helps you detect a gas leak. However, the odor added to these gases can fade. Gas may be present even though no odor exists.

Make certain you read and understand all warnings. Keep this manual for reference. It is your guide to safe and proper operation of this fireplace.

1. This appliance is only for use with the type of gas indicated on the rating plate. This appliance is not convertible for use with other gases unless a certified kit is used.
2. For propane/LP fireplace, do not place propane/LP supply tank(s) inside any structure. Locate propane/LP supply tank(s) outdoors. To prevent performance problems, do not use propane/LP fuel tank of less than 100 gal. capacity.
3. If you smell gas
 - shut off gas supply.
 - do not try to light any appliance.
 - do not touch any electrical switch; do not use any phone in your building .
 - immediately call your gas supplier from a neighbor’s phone. Follow the gas supplier’s instructions.

4. Never install the fireplace
 - in a recreational vehicle
 - where curtains, furniture, clothing, or other flammable objects are less than 42" from the front, top, or sides of the fireplace
 - in high traffic areas
 - in windy or drafty areas
5. This fireplace reaches high temperatures. Keep children and adults away from hot surfaces to avoid burns or clothing ignition. Fireplace will remain hot for a time after shutdown. Allow surfaces to cool before touching.
6. Carefully supervise young children when they are in the room with fireplace.
7. Do not modify fireplace under any circumstances. Any parts removed for servicing must be replaced prior to operating fireplace.
8. Turn fireplace off and let cool before servicing, installing, or repairing. Only a qualified service person should install, service, or repair the fireplace. Have burner system inspected annually by a qualified service person.
9. You must keep control compartments, burners, and circulating air passages clean. More frequent cleaning may be needed due to excessive lint and dust from carpeting, bedding material, pet hair, etc. Turn off the gas valve and pilot light before cleaning fireplace.
10. Have venting system inspected annually by a qualified service person. If needed, have venting system cleaned or repaired. Refer to *Cleaning and Maintenance*, page 41.
11. Keep the area around your fireplace clear of combustible materials, gasoline, and other flammable vapor and liquids. Do not run fireplace where these are used or stored. Do not place items such as clothing or decorations on or around fireplace.
12. Do not use this fireplace to cook food or burn paper or other objects.
13. Never place anything on top of fireplace.

14. Do not use any solid fuels (wood, coal, paper, cardboard, etc.) in this fireplace. Use only the gas type indicated on rating plate.
15. This appliance, when installed, must be electrically grounded in accordance with local codes or in the absence of local codes, with the *National Electrical Code, ANSI/NFPA 70*, or the *Canadian Electrical Code, CSA C22.1*.
16. Do not obstruct the flow of combustion and ventilation air in any way. Provide adequate clearances around air openings into the combustion chamber along with adequate accessibility clearance for servicing and proper operation.
17. When the appliance is installed directly on carpeting, tile or other combustible material other than wood flooring, you must set appliance on a metal or wood panel or hearth pad extending the full width and depth of the appliance.
18. Do not use fireplace if any part has been exposed to or under water. Immediately call a qualified service person to arrange for replacement of the unit.
19. Do not operate fireplace if any log is broken.
20. Do not use a blower insert, heat exchanger insert, or any other accessory not approved for use with this fireplace.
21. Do not operate the fireplace with glass door removed, cracked, or broken.
22. This unit is approved for bedrooms and bathrooms.

**IMPORTANT:
PLEASE READ THE FOLLOWING
CAREFULLY**

It is normal for fireplaces fabricated of steel to give off some expansion and/or contraction noises during the start up or cool down cycle. Similar noises are found with your furnace heat exchanger or car engine.

**IMPORTANT:
PLEASE READ THE FOLLOWING
CAREFULLY**

It is not unusual for gas fireplaces to give off some odor the first time it is burned. This is due to the manufacturing process.

Please ensure that your room is well ventilated during burn off — open all windows.

It is recommended that you burn your fireplace for at least ten (10) hours the first time you use it. Place the fan switch in the “OFF” position during this time.

WARNING

Never connect unit to private (non-utility) gas wells. This gas is commonly known as wellhead gas.


WARNING



HOT GLASS WILL CAUSE BURNS.

DO NOT TOUCH GLASS UNTIL COOLED.

NEVER ALLOW CHILDREN TO TOUCH GLASS.

**NATIONAL
FIREPLACE
INSTITUTE**



CERTIFIED

www.nficertified.org

We recommend that our gas hearth products be installed and serviced by professionals who are certified in the U.S. by the National Fireplace Institute® (NFI) as NFI Gas Specialists.

CODE APPROVAL

Direct Vent type appliances draw all combustion air from outside of the dwelling through the vent pipe.

These appliances have been tested by CSA and found to comply with the established standards for DIRECT VENT GAS FIREPLACE HEATERS in the USA and Canada as follows:

Listed Vented Gas Fireplace Heater

Tested To: ANSI Z21.88b-2008 / CSA 2.33b-2008 Standards

A manufactured home (USA only) or mobile home OEM installation must conform with the **Manufactured Home Construction and Safety Standard, Title 24 CFR, Part 3280**, or when such a standard is not applicable, the **Standard for Manufactured Home Installations, ANSI/NCSCS A225.1**, or **Standard for Gas Equipped Recreational Vehicles and Mobile Housing, CSA Z240.4**.

PRODUCT SPECIFICATIONS

- This appliance has been certified for use with either natural or propane gas. See appropriate data plates.
- This appliance is not for use with solid fuels.
- The appliance is approved for bedroom or bedsitting room installations.
- The appliance must be installed in accordance with local codes if any. If none exist use the current installation code. ANSI Z223.1/NFPA 54 in the USA, CSA B149 in Canada.
- This appliance is mobile home approved.
- This appliance is approved for bathroom installation.
- The appliance must be properly connected to a venting system.
- The appliance is not approved for closet or recessed installations.

The efficiency rating of this appliance is a product thermal efficiency rating determined under continuous operating conditions and was determined independently of any installed system.

HIGH ELEVATIONS

Input ratings are shown in BTU per hour and are certified without deration for elevations up to 4,500 feet (1,370 m) above sea level.

For elevations above 4,500 feet (1,370 m) in USA, installation must be in accordance with the current ANSI Z223.1/NFPA 54 and/or local codes having jurisdiction.

In Canada, please consult provincial and/or local authorities having jurisdiction for installation at elevations above 4,500 feet (1,370 m).

GAS PRESSURES

	Natural	Propane (LP)
Inlet Minimum	4.5" w.c.	11.0" w.c.
Inlet Maximum	10.5" w.c.	13.0" w.c.
Manifold Pressure	3.5" w.c.	10.0" w.c.

GAS SPECIFICATIONS & ORIFICE SIZE

Model	Fuel	Max. Input Btu/h	Min. Input Btu/h	Orifice Size
624DVNVC	Nat.	36,000	25,000	#44
624DVPVC	LP	36,000	26,000	#54
624DVNEC	Nat.	36,000	25,000	#44
624DVPEC	LP	36,000	26,000	#54

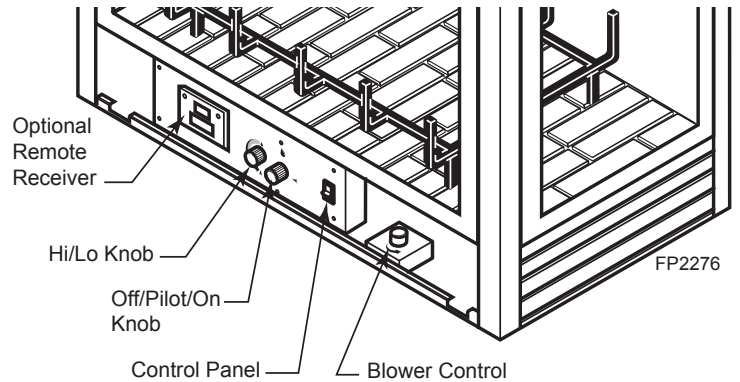


Figure 1 - Designer Series Fireplace Controls

BEFORE YOU START

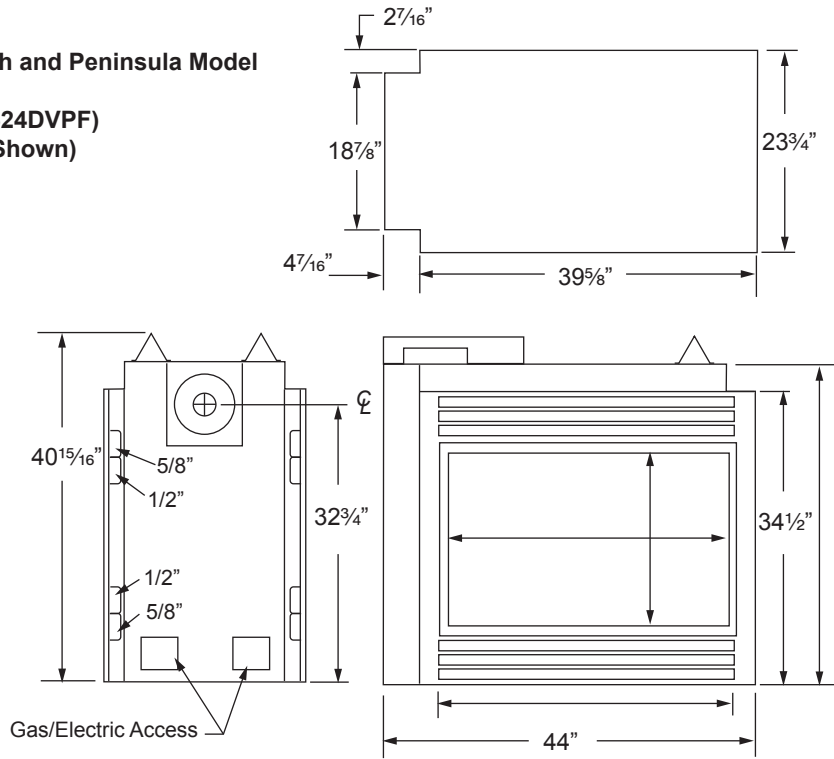
Read this homeowner manual thoroughly and follow all instructions carefully. Inspect all contents for shipping damage and immediately inform your dealer if any damage is found. Do not install any unit with damaged, incomplete, or substitute parts. Check your packing list to verify that all listed parts have been received. You should have the following:

- Fireplace (Firebox and Burner System)
- Log Set • Lava Rock • Rock Wool
- Deflector Shield (to be used with Simpson DuraVent Horizontal Termination – P/N 985)

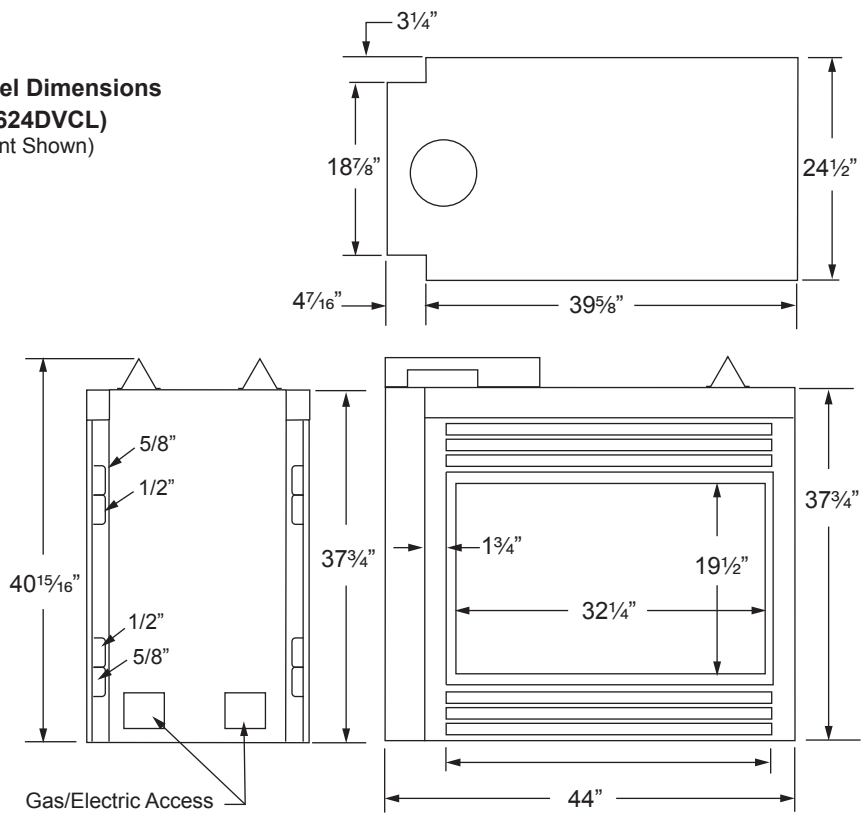
ITEMS REQUIRED FOR INSTALLATION

- Phillips Screwdriver
- Hammer
- Saw and/or saber saw
- Measuring Tape
- Tee Joint
- Square
- Caulking Material (Noncombustible)
- Fireplace Surround Material (Noncombustible)
- Piping Complying with Local Codes
- Pipe Sealant Approved for use with Propane/LPG (Resistant to Sulfur Compounds)
- Framing Materials
- Wall Finishing Materials
- Level
- Electric Drill and Bits
- Pliers
- Pipe Wrench

**See-Through and Peninsula Model Dimensions
(624DVST, 624DVPF)
(Rear Vent Shown)**



**Corner Model Dimensions
(624DVCR, 624DVCL)
(Right, Top Vent Shown)**



**Figure 2 -
Fireplace Dimensions**

It is best to build firebox framing **AFTER** the appliance is set in place. Refer to the dimensions for your fireplace on Page 7. The framing headers may rest on the top of the firebox standoffs.

The firebox may be installed directly on a combustible floor or raised on a platform of an appropriate height. Do not place firebox on carpeting, vinyl, or other soft floor coverings. It may, however, be placed on a flat wood, plywood, particle board, or other hard surfaces. Be sure firebox rests on a solid continuous floor or platform with appropriate framing for support. No cold air should enter room from under the firebox.

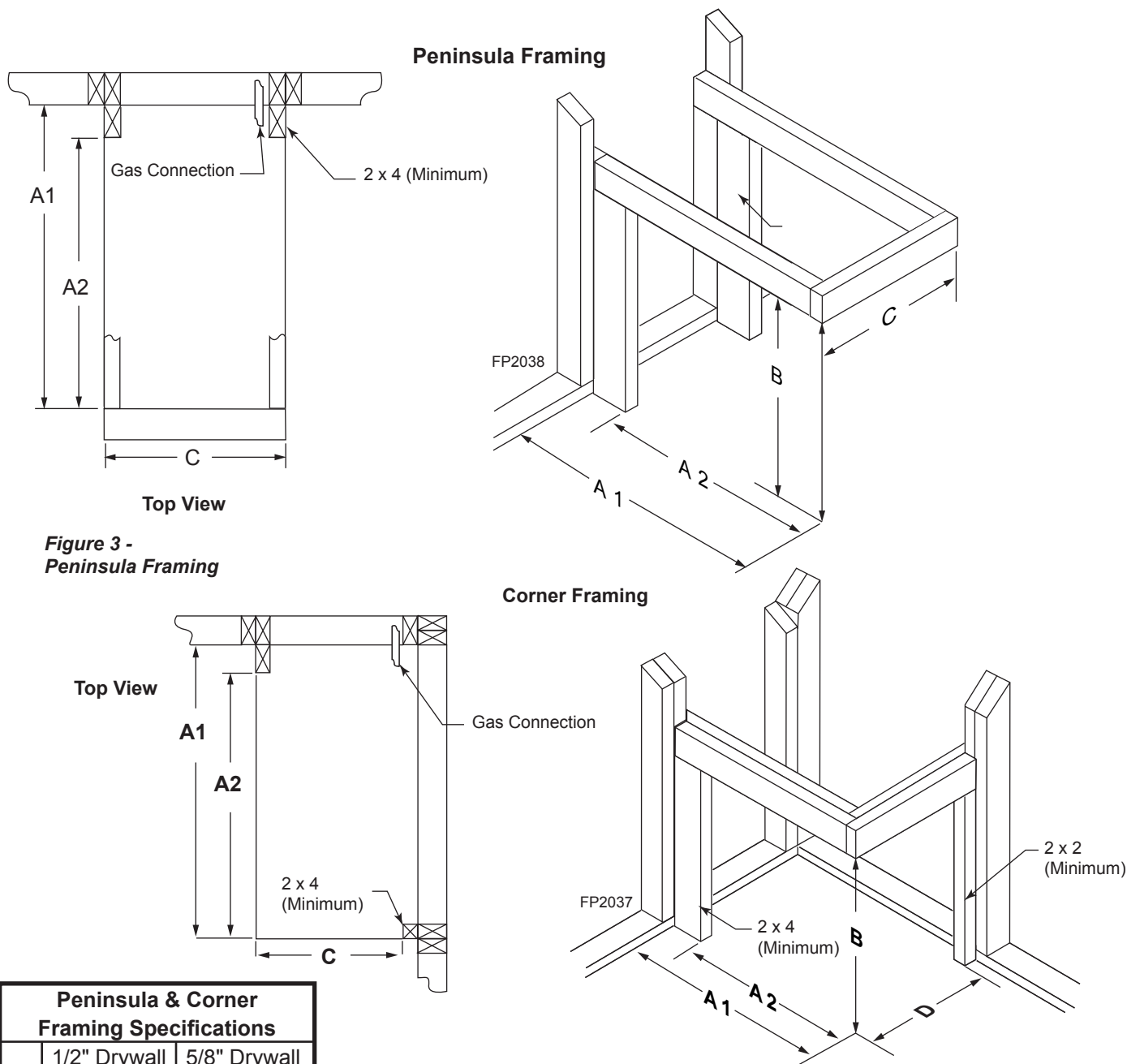


Figure 3 - Peninsula Framing

Figure 4 - Corner Unit Framing (Right Hand Configuration shown)

Peninsula & Corner Framing Specifications		
	1/2" Drywall	5/8" Drywall
A1	43½"	43⅝"
A2	39⅞"	39¾"
B	41⅛"	41⅛"
C	22¾"	22½"
D	24"	23⅞"

FRAMING SEE THROUGH FIREPLACE

* **NOTE:** For ease of installation, frame around the firebox after it has been set. Refer to chart below for specifications.

When installing into existing framed (A1) openings, loosen the junction box. Remove the rear-mounted flue pipe adaptor. Refer to Page 16, Figures 10 and 11. Reattach both assemblies.

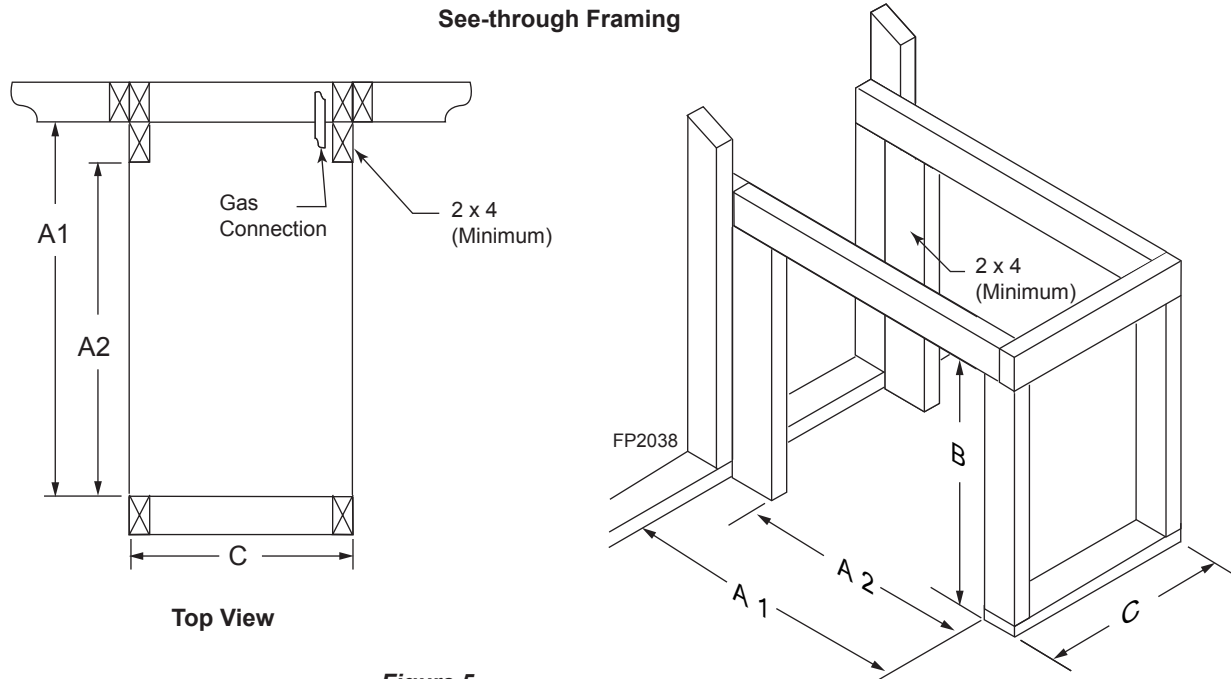


Figure 5 - See-Through Framing

See-through Framing Specifications		
	1/2" Drywall	5/8" Drywall
A1	44 1/4"	44 1/4"
A2	40 5/8"	40 5/8"
B	41 1/8"	41 1/8"
C	22 3/4"	22 1/2"

WARNING The fireplace must be installed giving full consideration to the clearance and height requirements identified in this manual.

CLEARANCES TO COMBUSTIBLES

WARNING

Follow these instructions carefully to ensure safe installation. Failure to follow instructions exactly can create a fire hazard.

The appliance cannot be installed on a carpet, tile or other combustible material other than wood flooring. If installed on carpet or vinyl flooring, the appliance shall be installed on a metal, wood or noncombustible material panel extending full width and depth of the appliance.

MANTEL CLEARANCES

NOTE: The combustible area above the facing must not protrude more than 3/4" from the facing. If it does, it is considered a mantel and must meet the mantel requirements listed in this manual.

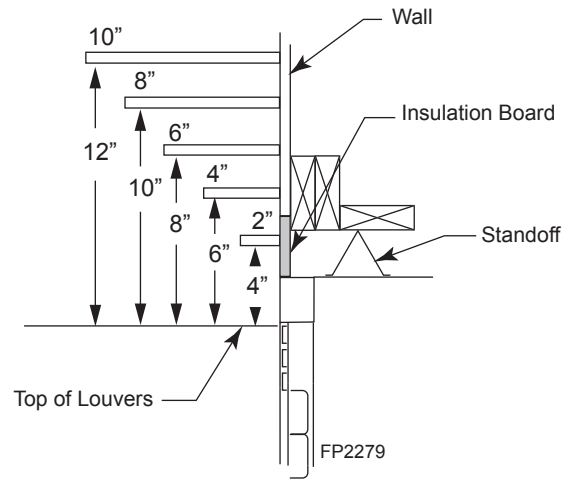


Figure 6 - Mantel Clearances

WARNING

Never obstruct or modify the air inlet or outlet grills (louvers). This may create a fire hazard.

FINISHING MATERIAL

NOTE: Any remote wiring (i.e. remote control, wall switch, and optional fan) must be done prior to final finishing to avoid costly reconstruction.

Only noncombustible materials (i.e. brick, tile, slate, steel, or other materials with a UL fire rating of Zero) may be used to cover the black-painted face of the appliance. A 300°F minimum adhesive may be used to attach facing materials to the black surface. If joints between the finished wall and the fireplace surround are sealed, a 300°F minimum sealant material (General Electric RTV103 or equivalent) must be used. Combustibles may come to the top and side edges but not overlay the face.

INSTALLATION AND OPERATING INSTRUCTIONS

This gas fireplace should be installed by a qualified installer in accordance with local building codes and with current CSA-B149 (.1 or .2) Installation codes for Gas Burning Fireplaces and Equipment. If the unit is being installed in a mobile home the installation should comply with the current CAN/CSA Z 240 .4 code.

FOR U.S.A. Installations follow local codes and/or the current National Fuel Gas Code. ANSI Z223.1.

FIREPLACE LOCATION

For Safe Installation and Operation Please Note The Following:

1. This fireplace gives off high temperatures and should be located out of high traffic areas and away from furniture and draperies.
2. Children and adults should be alerted to the hazards of the high surface temperatures of this fireplace and should stay away to avoid burns or ignition of clothing.
3. Caution, due to high glass surface temperature children should be carefully supervised when they are in the same room as the fireplace.
4. Under no circumstances should this fireplace be modified. Parts removed for servicing should be replaced prior to operating the fireplace again.
5. Installation and any repairs to this fireplace should be carried out by a qualified service person. A professional service person should be contacted to inspect this fireplace annually. Make it a practice to have all of your gas fireplaces checked annually. More frequent cleaning may be required due to excess lint and dust from carpeting, bedding material, etc.
6. Control compartments, burners and air passages in this fireplace should be kept clean and free of dust and lint. Make sure that the gas valve and pilot light are turned off before you attempt to clean this fireplace.
7. The venting system (chimney) of this fireplace should be checked at least once a year and if needed your venting system should be cleaned.
8. Keep the area around your fireplace clear of combustible materials, gasoline and other flammable vapor and liquids. This fireplace should not be used as a drying rack for clothing, nor should Christmas stockings or decorations be hung on or around the fireplace.
9. Under no circumstances should any solid fuels (wood, coal, paper or cardboard etc.) be used in this fireplace.
10. The flow of combustion and ventilation air must not be obstructed in any way.
11. When the fireplace is installed directly on carpeting, vinyl tile or any combustible material other than wood, the fireplace must be installed on a metal or wood panel extending the full width and depth of the fireplace.
12. This fireplace requires adequate ventilation and combustion air to operate properly.
13. This fireplace must not be connected to a chimney flue serving a separate solid fuel burning fireplace.
14. When the fireplace is not in use it is recommended that the gas control valve be left in the "OFF" position.

This appliance has been approved for after-market mobile home installations.

IMPORTANT:

PLEASE READ THE FOLLOWING CAREFULLY

Remove any plastic from trim parts before turning the fireplace ON.

It is normal for fireplaces fabricated of steel to give off some expansion and/or contraction noises during the start up or cool down cycle. Similar noises are found with your furnace heat exchanger or car engine.

It is not unusual for your Monessen gas fireplace to give off some odor the first time it is burned. This is due to the curing of the paint and any undetected oil from the manufacturing process.

Please ensure that your room is well ventilated — open all windows.

It is recommended that you burn your Monessen fireplace for a least ten (10) hours the first time you use it. If the optional fan kit has been installed, place the fan switch in the "OFF" position during this time.

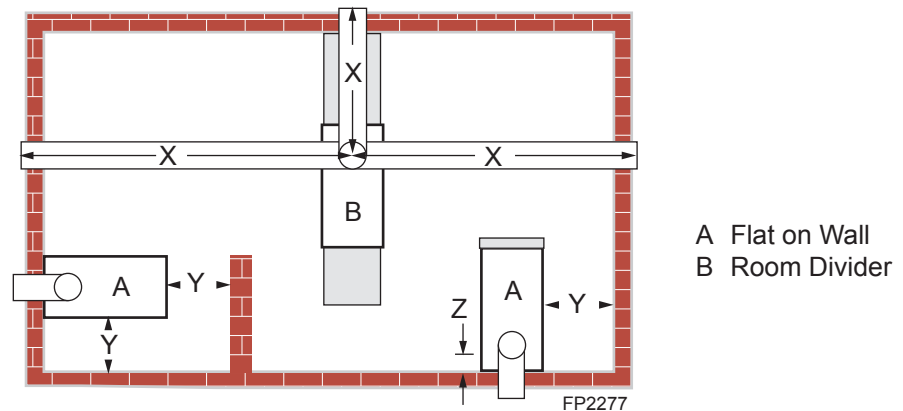


Figure 7 - Possible Fireplace Locations

A. WALL LOCATION

- Y Minimum distance between a glass panel and a parallel wall = 42"
- Z Minimum distance between the edge of a glass panel and an adjacent wall = 3"

B. Island Location

- X (Maximum length of horizontal venting = 20'. Refer to the venting section of this manual for specific dimensions.

SECURE FIREPLACE TO FLOOR

The fireplace must be secured to the floor and/or to framing studs as shown in *Figure 8*. Use two (2) wood screws or masonry/ concrete screws to secure fireplace to the floor. Use four (4) screws to attach fireplace to framing. The side brackets are adjustable from 1/2" to 5/8" to accommodate different thickness of noncombustible material.

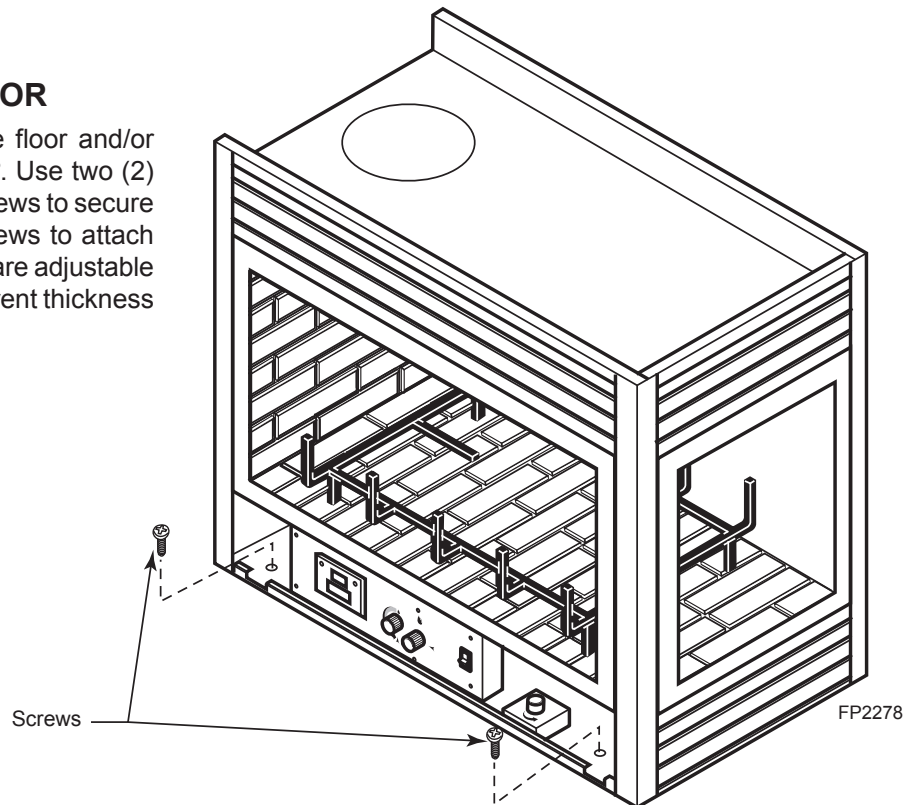


Figure 8 - Secure Fireplace to Floor and Framing Studs

OPTIONAL TOP VENT APPLICATION

The appliance is shipped as a rear vent unit. If the installation layout requires the unit to be a top vent configuration the appliance can be converted by following the steps below.

When removing and refitting the plates and adapter be sure the associated gaskets are undamaged and refitted as required.

1. Remove the eight (8) screws securing the flue pipe adapter to the fireplace body. *Figure 9*
2. Set the flue pipe adapter aside, complete with the gasket. Do not damage the gaskets as the adapter and gasket must be refitted.
3. Remove the eight (8) screws securing the flue pipe cover to the top of the intake box and remove the cover and gasket. *Figure 9*
4. Remove eight (8) screws securing the flue pipe to the back of the intake box and remove the pipe and gasket. *Figure 10*
5. Replace flue pipe to top of firebox. Ensure the gasket is in place and undamaged. Secure with eight (8) screws. *Figure 11*
6. Place the flue pipe cover and gasket removed in step 3 over the flue opening in bottom of the intake box.
7. Refit the flue pipe adapter and gasket to the top of fireplace. Secure the adapter with eight (8) screws removed in step 1.

WARNING After conversion to top vent configuration the 4" (102 mm) flue pipe should be concentric within the 6⁵/₈" (175 mm) outer collar (within 1/4").

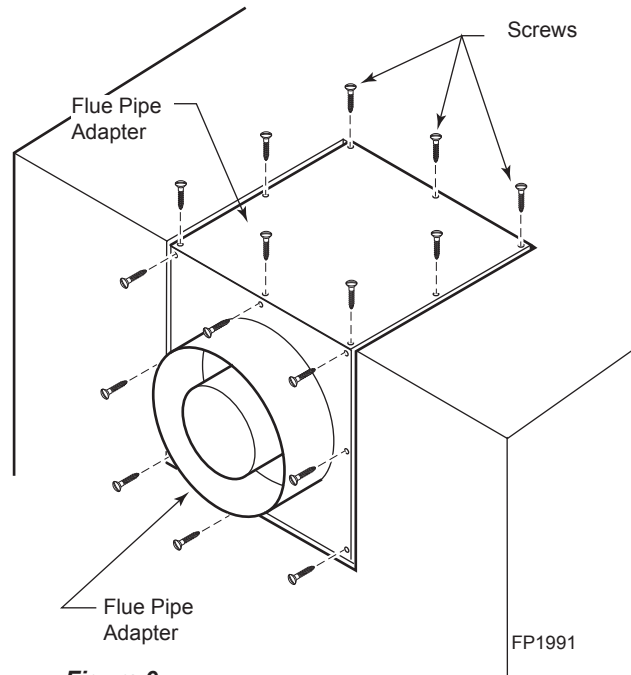


Figure 9 - Remove 16 Screws from Flue Pipe Adapter and Flue Pipe Cover

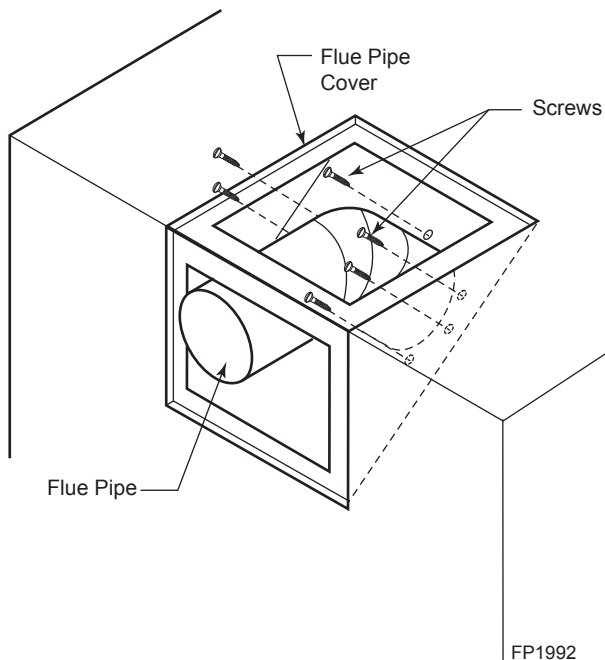


Figure 10 - Remove Flue Pipe

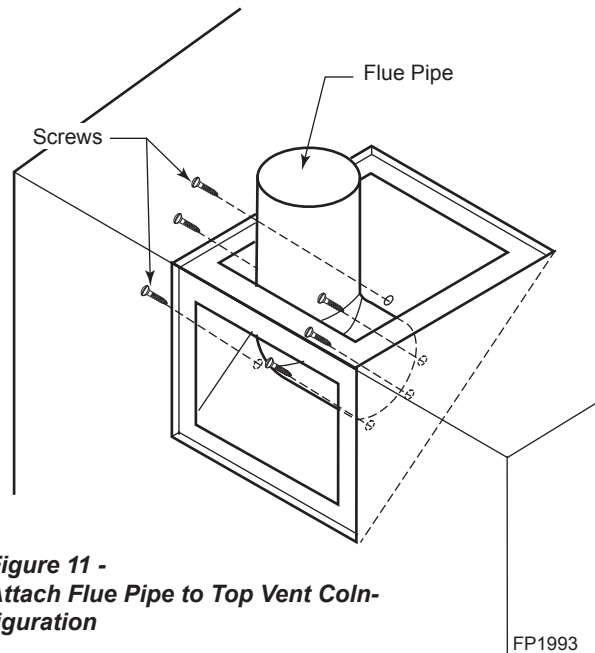


Figure 11 - Attach Flue Pipe to Top Vent Configuration

VENTING INSTALLATION

WARNING
 Read all instructions completely and thoroughly before attempting installation. Failure to do so could result in serious injury, property damage or loss of life. Operation of improperly installed and maintained venting system could result in serious injury, property damage or loss of life.

NOTICE
 Failure to follow these instructions will void the warranty.

INSTALLATION PRECAUTIONS

NOTE: This appliance must be installed with a Monessen approved venting system only.

Consult local building codes before beginning the installation. The installer must make sure to select the proper vent system for installation. Before installing vent kit, the installer must read this fireplace manual and vent kit instructions.

Only a qualified installer/service person should install venting system. The installer must follow these safety rules:

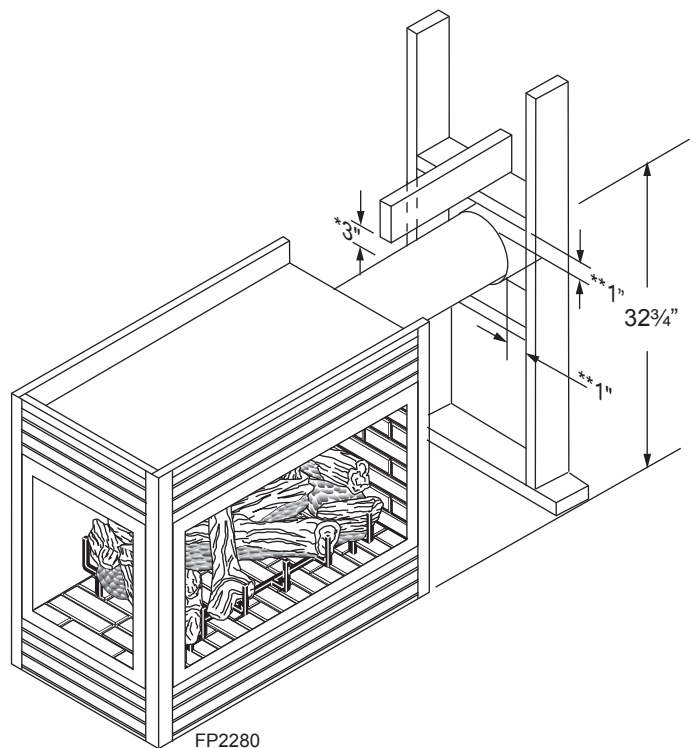
- Wear gloves and safety glasses for protection.
- Use extreme caution when using ladders or when on rooftops.
- Be aware of electrical wiring locations in walls and ceilings.

The following actions will void the warranty on your venting system:

- Installation of any damaged venting component.
- Unauthorized modification of the venting system.
- Installation of any component part not manufactured or approved by MHSC.
- Installation other than permitted by these instructions.

VENTING CLEARANCES

WARNING
 Horizontal sections of this vent system require a minimum of 3" clearances to combustibles at the top of the flue and 1" clearance at the sides and bottom *until the flue penetrates the outside wall*. A minimum 1" clearance all around the flue is acceptable at this point of penetration. Vertical sections of this vent system require a minimum of 1" clearance to combustibles on all sides of the pipe.



* A minimum of 3" clearance to the top is required along horizontal length until flue pipe penetrates outside wall.

** A minimum 1" clearance to combustibles permitted all around flue at outside wall.

Figure 12 - Combustible Clearances for Vent Pipe

WARNING
 This fireplace must be vented to the outside. The venting system must NEVER be attached to a chimney serving a separate solid fuel burning appliance. Each gas appliance must use a separate vent system. Do not use common vent systems.

INSTALLATION PLANNING

There are two basic types of direct-vent installation:

- Horizontal Termination
- Vertical Termination

It is important to select the proper length of vent pipe for the important to note the wall thickness.

WARNING

Never run the vent pipe down. This may cause excessive temperatures which could cause a fire.

of termination you choose. It is also

FOR HORIZONTAL TERMINATION

Select the amount of vertical rise desired. All horizontal run of venting must have 1/4" rise for every 12" of run towards the termination.

You may use up to three 90° elbows in this vent configuration. Refer to *Horizontal Termination Configurations* on Pages 22 and 23.

FOR VERTICAL TERMINATION

Measure the distance from the fireplace floor to the ceiling. Add the ceiling thickness, the vertical rise in an attic or second story, and allow for sufficient vent height above the roof line.

NOTE: You may use two 45° elbows in place of a 90° elbow. You must follow rise to run ratios when using 45° elbows. The appliance is approved for use with three 90° elbows maximum or a combination of 90° and 45° elbows up to a maximum of 270°.

For two-story applications, firestops are required at each floor level. If an offset is needed in the attic, additional pipe and elbows will be required.

You may use a chase with a vent termination with exposed pipe on the exterior of the house. Refer to *Installing Vent System in a Chase* below. If pipe is enclosed in chase, it is not exposed.

It is very important that the venting system maintain its balance between the combustion air intake and the flue gas exhaust. Certain limitations apply to vent configurations and must be strictly followed.

INSTALLING A VENT SYSTEM IN AN OUTSIDE CHASE

A chase is a vertical boxlike structure built to enclose venting that runs along the outside of a building. A chase is required for such venting.

WARNING

Treatment of firestops and construction of the chase may vary from building type to building type. These instructions are not substitutes for the requirements of local building codes. You must follow all local building codes.

NOTICE

When installing in a chase, you should insulate the chase as you would the outside walls of your home. This is especially important in cold climates. Insulation should be considered a combustible material. Maintain proper clearances to all combustible materials.

WARNING

Always maintain minimum clearances around vent systems. The minimum clearances to combustibles for horizontal vent pipe are 3" at the top and 1" at the sides and bottom of the vent system until the pipe penetrates the nearest vertical wall. A 1" minimum clearance all around the pipe must be maintained. Do not pack the open air spaces with insulation or other materials. This could cause high temperatures and may present a fire hazard.

GENERAL VENTING INFORMATION - TERMINATION LOCATION

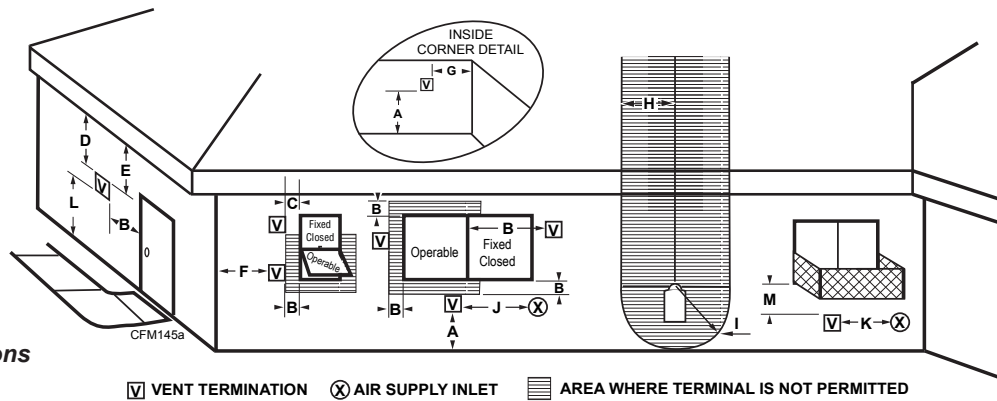


Figure 13 - Termination Locations

	Canadian Installations ¹	US Installations ²
A = Clearance above grade, veranda, porch, deck, or balcony	12" (30 cm)	12" (30 cm)
B = Clearance to window or door that may be opened	6" (15 cm) for appliances < 10,000BTU/h (3kW), 12" (30 cm) for appliances > 10,000 Btuh (3kW) and < 100,000 BTU/h (30kW), 36" (91 cm) for appliances > 100,000 BTU/h (30kW)	6" (15 cm) for appliances < 10,000 BTU/h (3kW), 9" (23 cm) for appliances > 10,000 Btuh (3kW) and < 50,000 BTU/h (15kW), 12" (30 cm) for appliances > 50,000 BTU/h(15kW)
C = Clearance to permanently closed window	12" (305 mm) recommended to prevent window condensation	12" (305 mm) recommended to prevent window condensation
D = Vertical clearance to ventilated soffit located above the terminal within a horizontal distance of 2' (610mm) from the center line of the terminal	18" (458 mm)	18" (458 mm)
E = Clearance to unventilated soffit	12" (305 mm)	12" (305 mm)
F = Clearance to outside corner	see next page	see next page
G = Clearance to inside corner (see next page)	see next page	see next page
H = Clearance to each inside of center line extended above meter/regulator assembly	3' (91 cm) within a height of 15' (5 m) above the meter/regulator assembly	3' (91 cm) within a height of 15' (5 m) above the meter/regulator assy
I = Clearance to service regulator vent outlet	3' (91 cm)	3' (91 cm)
J = Clearance to nonmechanical air supply inlet to building or the combustion air inlet to any other appliances	6" (15 cm) for appliances < 10,000 BTU/h (3kW), 12" (30 cm) for appliances > 10,000 BTU/h (3kW) and < 100,000 Btuh (30kW), 36" (91 cm) for appliances > 100,000 BTU/h (30kW)	6" (15 cm) for appliances < 10,000 BTU/h (3kW), 9" (23 cm) for appliances > 10,000 BTU/h (3kW) and < 50,000 BTU/h (15kW), 12" (30 cm) for appliances > 50,000 BTU/h(15kW)
K = Clearance to a mechanical air supply inlet	6' (1.83 m)	3' (91 cm) above if within 10' (3 m) horizontally
L = Clearance above paved sidewalk or paved driveway located on public property	7' (2.13 m)†	7' (2.13 m)†
M = Clearance under veranda, porch, deck or balcony	12" (30 cm)‡	12" (30cm)‡

1 In accordance with the current CSA-B149 Installation Codes
 2 In accordance with the current ANSI Z223.1/NFPA 54 National Fuel Gas Codes
 † A vent shall not terminate directly above a sidewalk or paved driveway which is located between two single family dwellings and serves both dwellings
 ‡ only permitted if veranda, porch, deck or balcony is fully open on a minimum 2 sides beneath the floor:

NOTE: 1. Local codes or regulations may require different clearances.
 2. The special venting system used on Direct Vent Fireplaces are certified as part of the appliance, with clearances tested and approved by the listing agency.
 3. MHSC assumes no responsibility for the improper performance of the appliance when the venting system does not meet these requirements.

TERMINATION CLEARANCES FOR BUILDINGS WITH COMBUSTIBLE AND NONCOMBUSTIBLE EXTERIORS

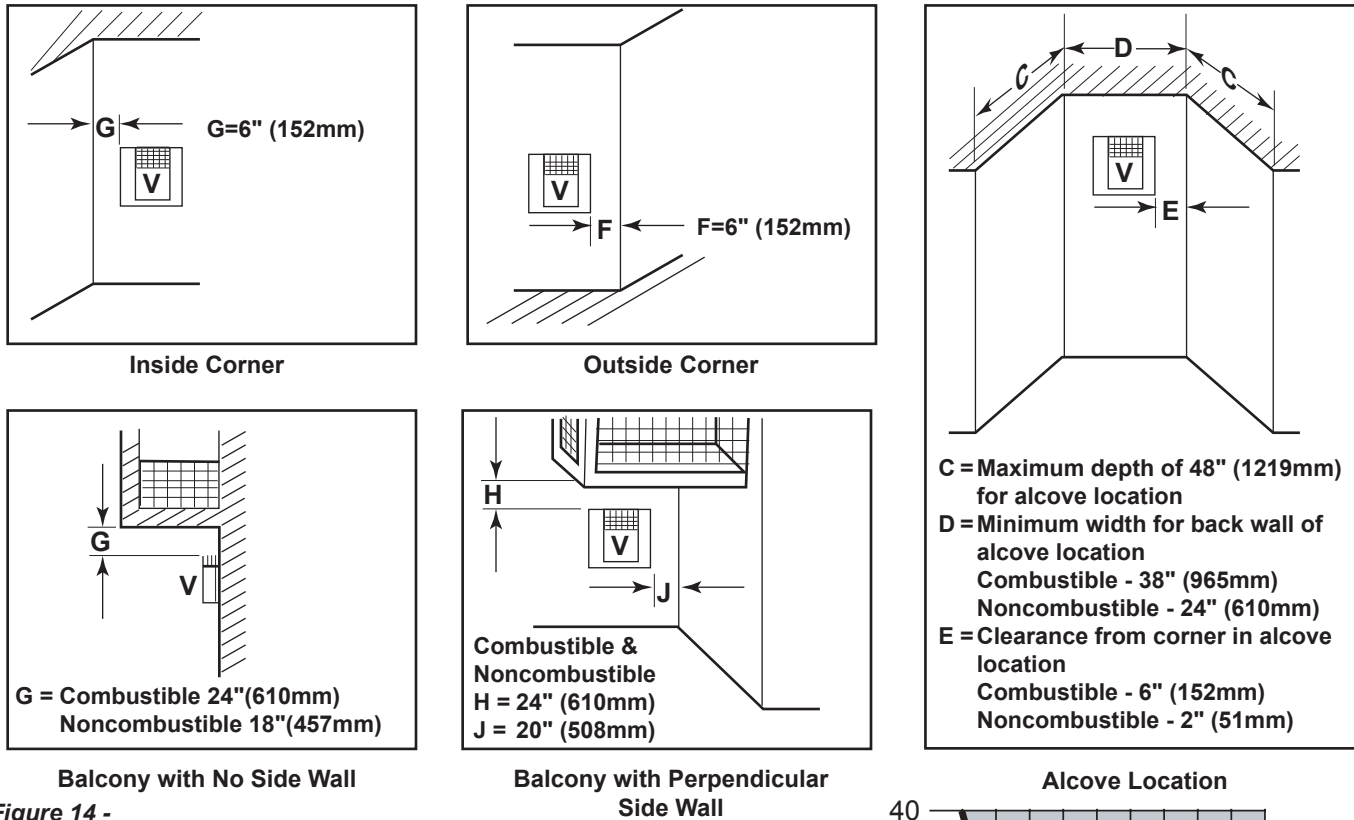


Figure 14 - Allowable Venting Chart

HOW TO USE THE VENT GRAPH

The Vent Graph should be read in conjunction with the following vent installation instructions to determine the relationship between the vertical and horizontal dimensions of the vent system.

1. Determine the height of the center of the horizontal vent pipe exiting through the outer wall. Using this dimension on the Sidewall Vent Graph below, locate the point intersecting with the slanted graph line.
2. From the point of this intersection, draw a vertical line to the bottom of the graph.
3. Select the indicated dimension, and position the fireplace in accordance with same.

Example: If the vertical dimension from the floor of the fireplace is 11' (3.4 m) the horizontal run to the face of the outer wall must not exceed 14' (4.3 m).

Example: If the vertical dimension from the floor of the unit is 7' (2.14m), the horizontal run to the face of the outer wall must not exceed 8½' (2.6 m).

Sidewall Vent Graph showing the relationship between vertical and horizontal dimensions for a Direct Vent flue system.

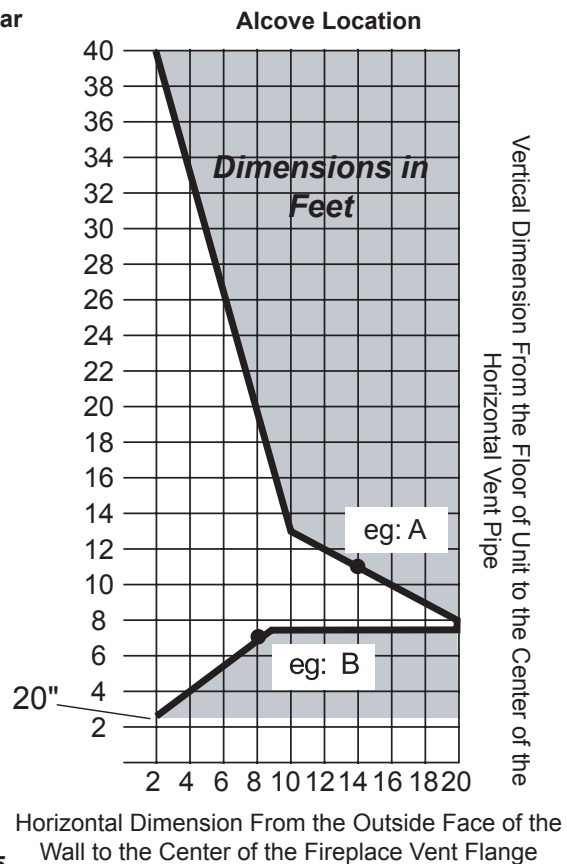


Figure 15 - Rear Wall Venting Graph

REAR WALL VENT INSTALLATION

When installed as a rear vent unit this appliance may be vented directly to a termination located on the rear wall behind the appliance

- The maximum horizontal distance between the rear of the appliance and the outside face of the rear wall is 20" (508 mm). *Figure 16*
- Only one 45° elbow is allowed in these installations.

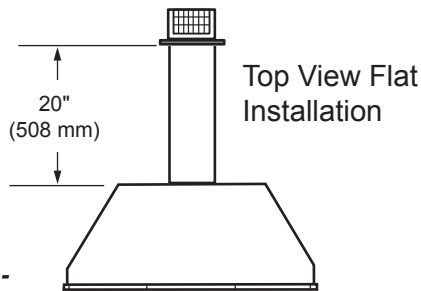


Figure 16 - Rear Vent Application, Maximum Horizontal Distance

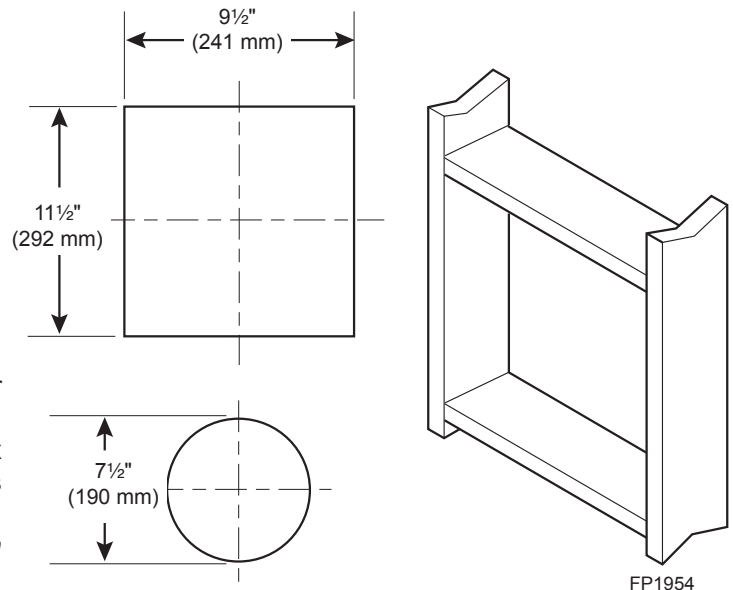


Figure 17 - Vent Opening Requirements

1. Locate and cut the vent opening in the wall. For combustible walls first frame in opening.
Combustible Walls: Cut a 11 1/2"H x 9 1/2" W (292 x 241 mm) hole through the exterior wall and frame as shown. *Figure 17*

Noncombustible Walls: Hole opening should be 7 1/2" (190 mm) in diameter.

2. Rigid vent pipes and fittings have special twist-lock connections. Assemble the desired combination of pipe and elbows to the appliance adaptor with pipe seams oriented towards the wall or floor.

Twist-lock Procedure: The female ends of the pipes and fittings have three locking lugs (indentations). These lugs will slide straight into matching slots on the male end of adjacent pipes and fittings. Push the pipe sections together and twist one section clockwise approximately one-quarter turn until the sections are fully locked. *Figure 18*

3. Attach vent pipe assembly to the fireplace. Set fireplace in front of its permanent location to insure minimum clearances. Mark the wall for a 11 1/2"H x 9 1/2"W (292 x 241 mm) rectangle hole (for noncombustible material such as masonry block or concrete, a 7 1/2" [190 mm] diameter hole is acceptable). *Figure 17*. The center of the hole should line up with the center line of the horizontal rigid vent pipe end. Be sure to allow for minimum rise. Cut a 11 1/2"x9 1/2" rectangle hole through combustible exterior wall (7 1/2" diameter hole if noncombustible). Frame as necessary. Allow 1/4" minimum rise per foot. *Figure 17*

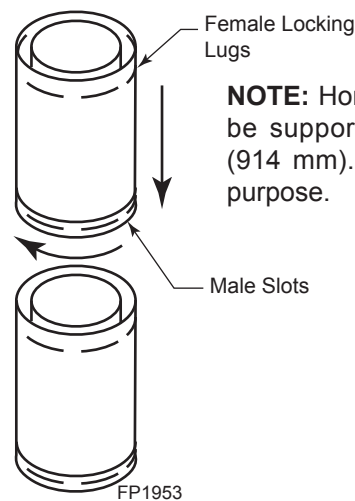


Figure 18 - Rigid Vent Pipe Connections

REAR WALL VENT INSTALLATION (continued)

4. Apply a bead of non-hardening mastic around the outside edge of vent cap. Position the vent cap in the center of hole on the exterior wall with the word "UP" on the vent cap facing up. Insure proper clearance of 1" to combustibles is maintained. Attach the vent cap with four wood screws supplied. *Figure 19*

NOTE: Replace the wood screws with appropriate fasteners for stucco, brick, concrete, or other types of siding.

For vinyl siding, stucco, or wood exterior use vinyl siding standoffs between vent cap and exterior wall. The vinyl siding standoff prevents excessive heat from melting the vinyl siding material. Bolt the vent cap to the standoff. Apply non-hardening mastic around outside edge of the standoff instead of the vent cap assembly. Use wood screws provided to attach the standoff. *Figure 20*

5. Slide fire stop over the vent pipe before connecting horizontal run to vent cap. *Figure 21*

6. Insert vent pipe into the horizontal termination. The pipe overlap should be a minimum of 1 1/4". Fasten all vent connections with screws provided.

7. Slide fire stop against the interior wall surface and attach with screws. *Figure 21*

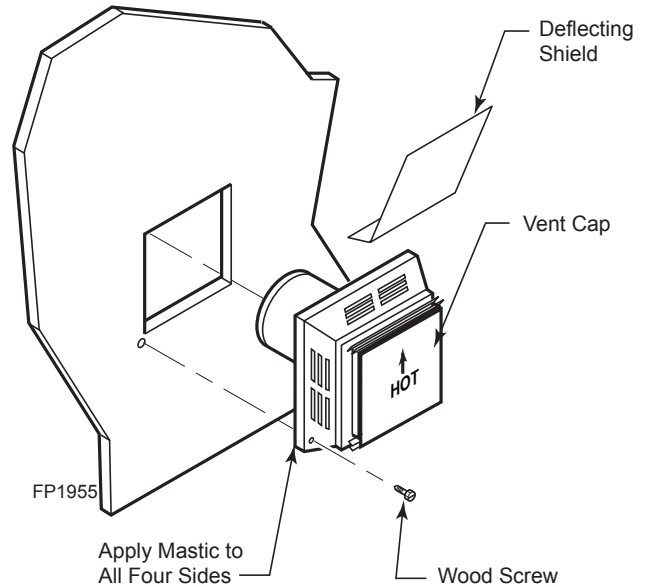


Figure 19 - Installing Horizontal Vent Cap

WARNING

Do not recess vent termination into any wall. This will cause a fire hazard.

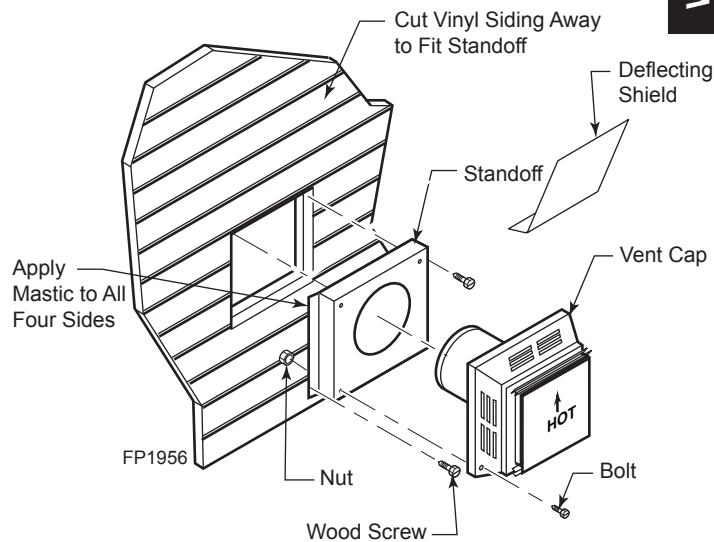


Figure 20 - Installing Vinyl Siding Standoff

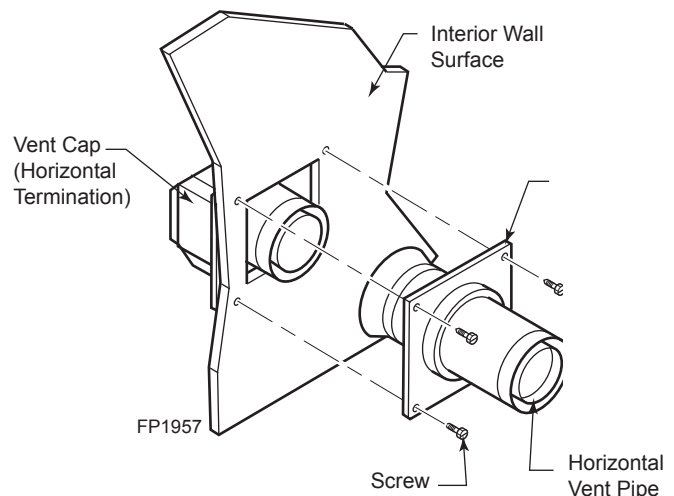


Figure 21 - Connecting Vent Cap with Horizontal Vent Pipe

HORIZONTAL TERMINATION CONFIGURATIONS

Since it is very important that the venting system maintain its balance between the combustion air intake and the flue gas exhaust, certain limitations as to vent configurations apply and must be strictly adhered to.

The Vent Graph, showing the relationship between vertical and horizontal side wall venting, will help to determine the various dimensions allowable. *Figure 22*

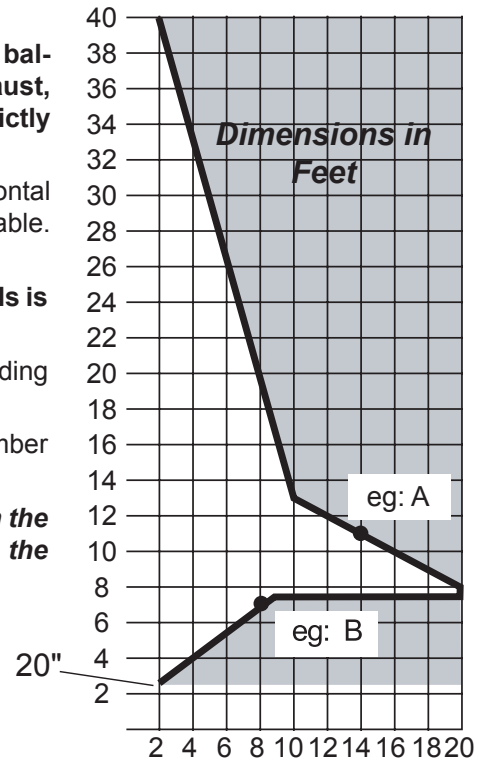
Minimum clearance between vent pipes and combustible materials is 3" on top and 1" from bottom and sides unless otherwise noted.

When vent termination exits through foundations less than 20" below siding outcrop, the vent pipe must flush up with the siding.

It is best to locate the fireplace in such a way that minimizes the number of offsets and horizontal vent length.

The horizontal vent run refers to the total length of vent pipe from the flue collar of the fireplace (or the top of the Transition Elbow) to the face of the outer wall.

- The maximum number of 90° elbows per side wall installation is three (3). *Figure 23*
- If a 90° elbow is fitted directly on top of the fireplace flange the maximum horizontal vent run before the termination or a vertical rise is 36" (914 mm). *Figure 24*



Horizontal Dimension From the Outside Face of the Wall to the Center of the Fireplace Vent Flange
Figure 22 - Rear Wall Venting Graph

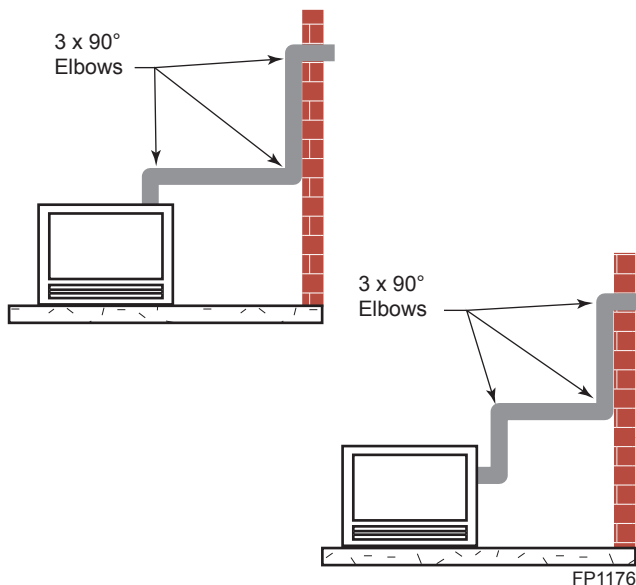


Figure 23 - Maximum Three (3) 90° Elbows Per Installation

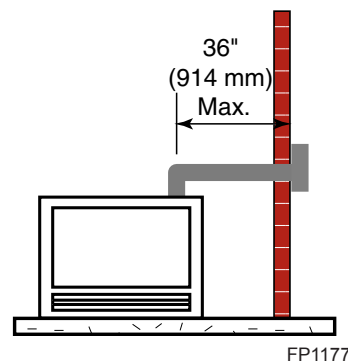


Figure 24 - Maximum Horizontal Run with No Rise

HORIZONTAL TERMINATION CONFIGURATION (Continued)

- If a 90° elbow is used in the horizontal vent run, the horizontal vent length is reduced by 36" (914 mm). *Figure 25*. This does not apply if the 90° elbows are used to increase or redirect a vertical rise. *Figure 25*

Example: According to the vent graph, *Figure 22*, the maximum horizontal vent length in a system with a 7.5' vertical rise is 20' (6 m) and if a 90° elbow is required in the horizontal vent it must be reduced to 17' (5.2 m). Refer to Page 17 "How to Use Vent Graph."

In *Figures 26 and 27*, Dimension A plus B must not be greater than 17' (5.2 m).

- The maximum number of 45° elbows permitted per side wall installation is two (2). These elbows can be installed in either the vertical or horizontal run.
- For each 45° elbow installed in the horizontal run, the length of the horizontal run **MUST** be reduced by 18" (45 cm). This does not apply if the 45° elbows are installed on the vertical part of the vent system.
- The maximum number of elbow degrees in a system is 270°. *Figure 27*

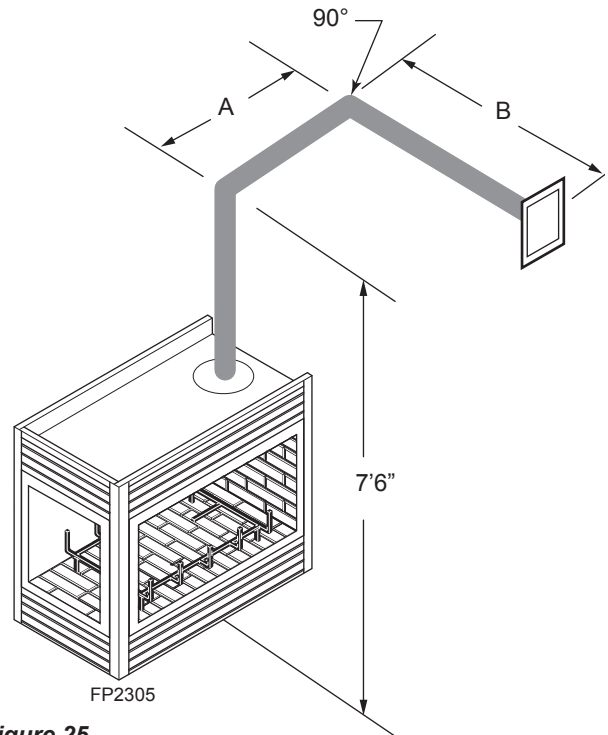


Figure 25 - Horizontal Run Reduction

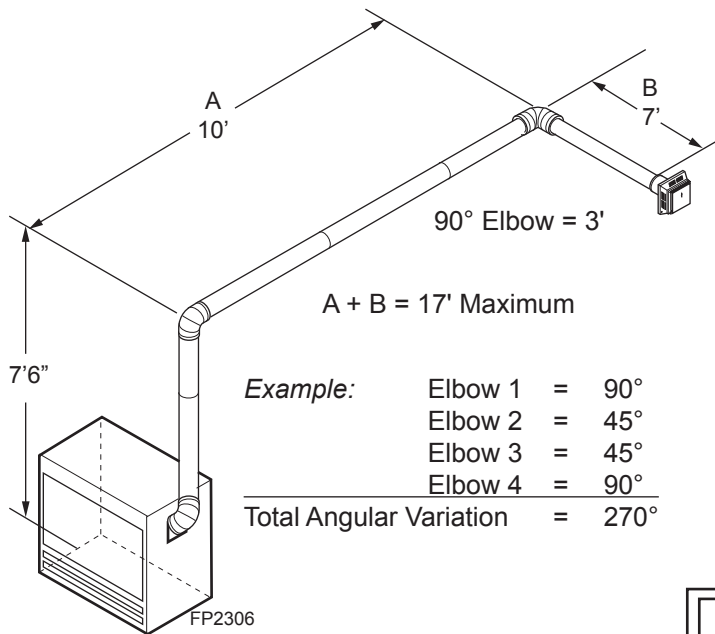


Figure 26 - Maximum Vent Run with Elbows

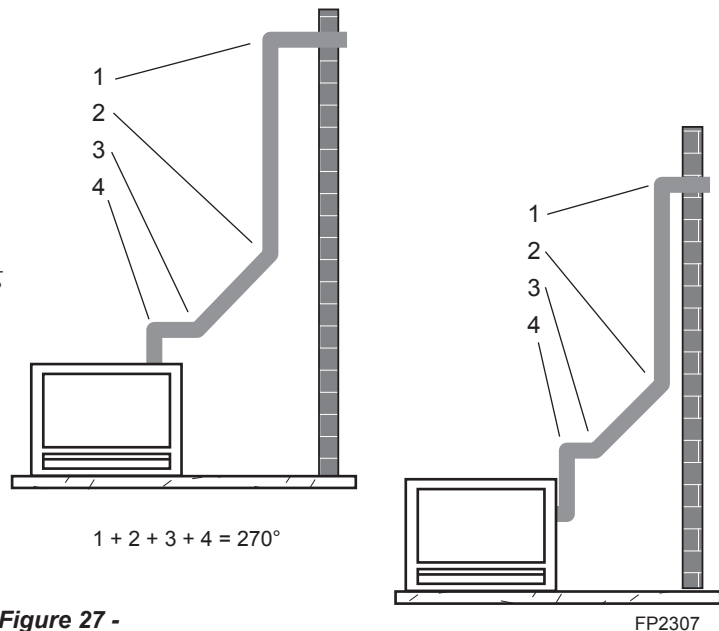


Figure 27 - Maximum Elbow Usage

BELOW GRADE INSTALLATIONS

When it is not possible to meet the required vent terminal clearances of 12" above grade level, a snorkel kit is recommended. It allows installation depth down to 7" (178 mm) below grade level. The 7" (178 mm) is measured from the center of the horizontal vent pipe as it penetrates through the wall.

Ensure that sidewall venting clearances are observed. If venting system is installed below ground, we recommend a window well with adequate and proper drainage to be installed around the termination area.

If installing a snorkel, a minimum 24" vertical rise is necessary. The maximum horizontal run with the 24" vertical pipe is 36". This measurement is taken from the collar of the fireplace (or transition elbow) to the face of the exterior wall. Refer to the Sidewall Venting Graph for extended horizontal run if the vertical exceeds 24".

1. Establish vent hole through the wall. *Refer to Page 18, Figure 17*
2. Remove soil to a depth of approximately 16" below base of snorkel. Install drain pipe. Install window well (not supplied). Refill hole with 12" of coarse gravel leaving a clearance of approximately 4" below snorkel. *Figure 28*
3. Install vent system.
4. Ensure a watertight seal is made around the vent pipe coming through the wall.
5. Slide the snorkel into the vent pipes and secure to the wall.
6. Level the soil so as to maintain a 4" clearance below snorkel. *Figure 28*

WARNING	<ul style="list-style-type: none"> Do not back fill around snorkel. A clearance of at least 4" must be maintained between the snorkel and the soil.
----------------	---

If the foundation is recessed, use recess brackets (not supplied) for securing lower portion of the snorkel. Fasten brackets to wall first, then secure to snorkel with self drilling #8 x 1/2" sheet metal screws. It will be necessary to extend vent pipes out as far as the protruding wall face. *Figure 28*

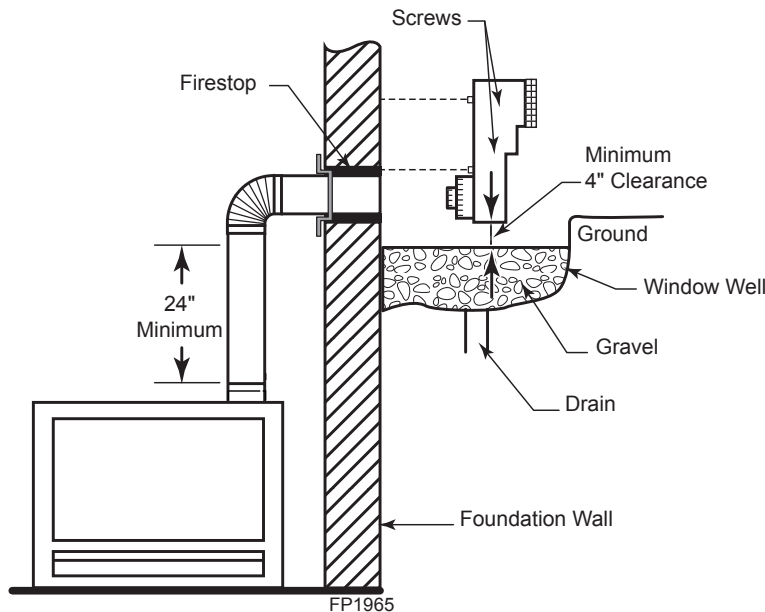


Figure 28 - Below Grade Installation

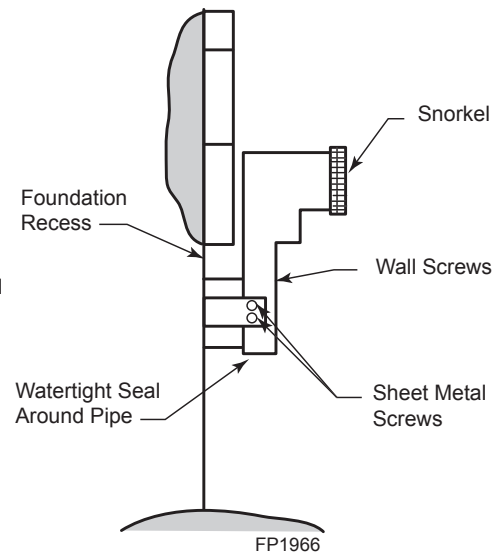


Figure 29 - Snorkel Installation, Recessed Foundation

VERTICAL THROUGH-THE-ROOF APPLICATIONS

This Gas Fireplace has been approved for,

- Vertical installations up to 40' (12 m) in height. Up to a 10' (3 m) horizontal vent run can be installed within the vent system using a maximum of two 90° elbows. *Figure 28*

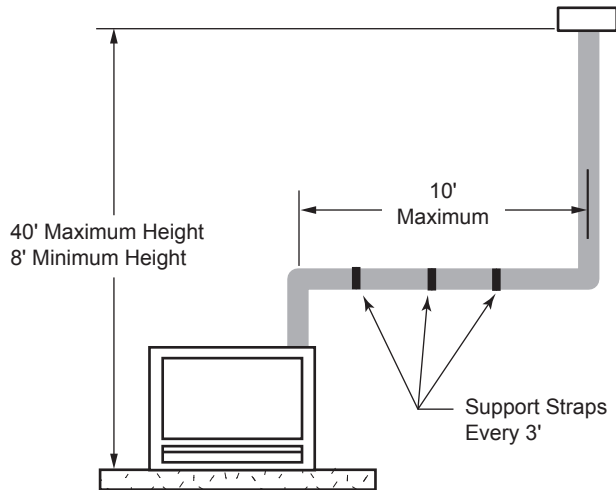
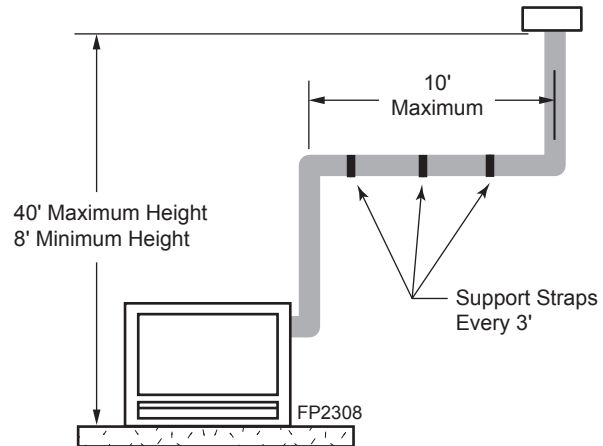


Figure 30 - Support Straps for Horizontal Runs



- Up to two 45° elbows may be used within the horizontal run. For each 45° elbow used on the horizontal plane, the maximum horizontal length must be reduced by 18" (450 mm).

Example: Maximum horizontal length

- No elbows = 10' (3 m)
- 1 x 45° elbows = 8.5' (2.6 m)
- 2 x 45° elbows = 7' (2.1 m)

- A minimum of an 8' (2.5 m) vertical rise is required.
- Two sets of 45° elbows offsets may be used within the vertical sections. From 0 to a maximum of 8' (2.5 m) of vent pipe can be used between elbows. *Figure 31*
- The maximum angular variation allowed in the system is 270°. *Figure 31*
- The minimum height of the vent above the highest point of penetration through the roof is 2' (610 mm).

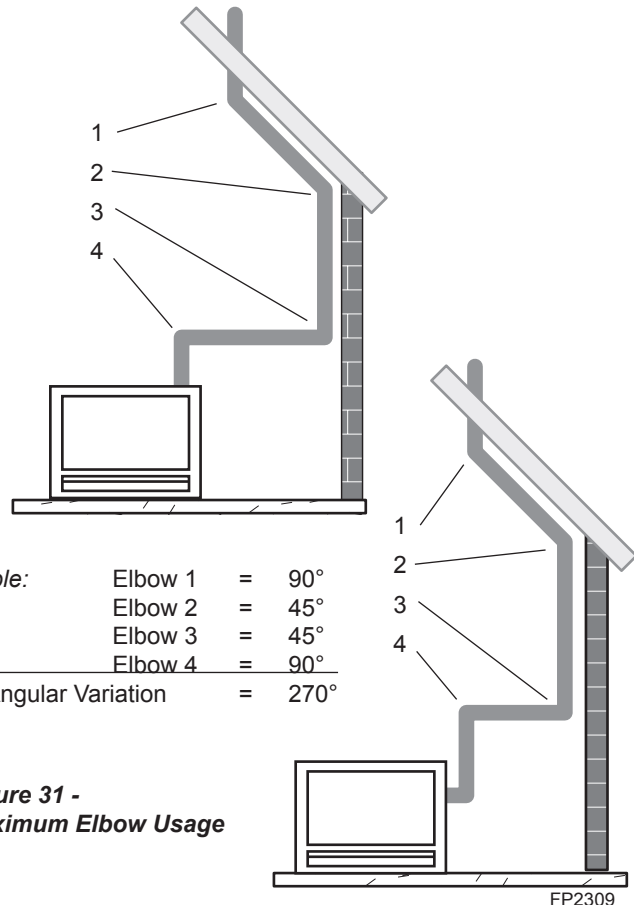


Figure 31 - Maximum Elbow Usage

INSTALLATION FOR VERTICAL TERMINATION

1. Determine the route your vertical venting will take. If ceiling joist, roof rafters or other framing will obstruct the venting system, consider an offset. Refer to Figure 32 to avoid cutting load bearing members.

NOTE: Pay special attention to these installation instructions for required clearances (air space) to combustibles when passing through ceilings, walls, roofs, enclosures, attic rafters, etc. Do not pack air spaces with insulation. Also note maximum vertical rise of the venting system and any maximum horizontal offset limitations. Offsets must fall within the parameters shown on Page 20, Figure 22.

2. Set fireplace in desired location. Drop a line plumb down from the ceiling to the position of the flue exit. Mark the center point where the vent will penetrate the ceiling. Drill a small locating hole at this point.

Drop a plumb line from the inside of the roof to the ceiling locating hole in the ceiling. Mark the center point where the vent will penetrate the roof. Drill a small locating hole at this point.

FLAT CEILING INSTALLATION

1. Cut a 9½" (241 mm) square hole in the ceiling using the locating hole as a center point. The opening should be framed to 9½" x 9½" (241 x 241 mm) inside dimensions as shown in Figure 33 using framing lumber the same size as the ceiling joist. If the area above the ceiling is an insulated ceiling or a room, nail firestop from the top side. This prevents loose insulation from falling into the required clearance space. Figure 33. Otherwise, install firestop below the framed hole.
2. Assemble the desired lengths of pipe and elbows necessary to reach from the burner system flue up through the firestop. Be sure pipe and elbow connections are fully twist-locked. Page 18, Figure 18
3. Cut a hole in the roof using the locating hole as a center point. (Cover any exposed open vent pipes before cutting hole in roof). The 9½" x 9½" (241 x 241 mm) hole must be measured on the horizontal. Actual length may be larger depending on the pitch of the roof. There must be a 1" minimum clearance from the vent pipe to combustible materials. (Insulation should be considered a combustible material) Frame the opening as shown on Page 18, Figure 17.

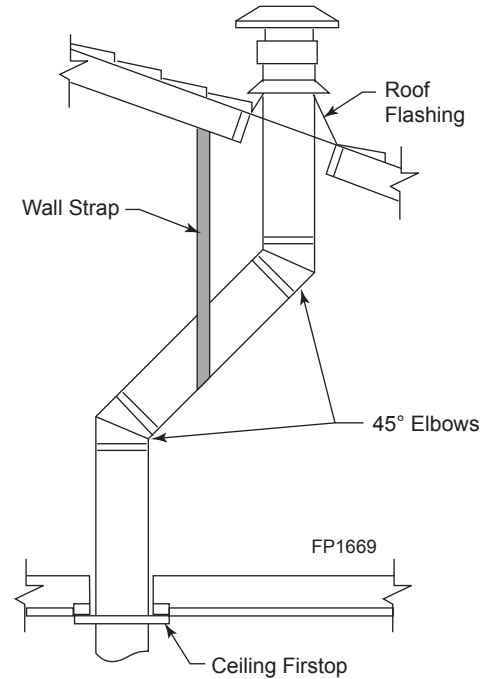


Figure 32 - Offset with Wall Strap and 45° Elbows

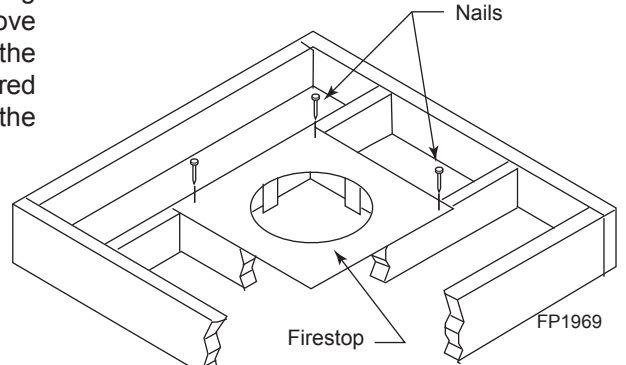


Figure 33 - If area above is a room, install firestop above framed hole as shown

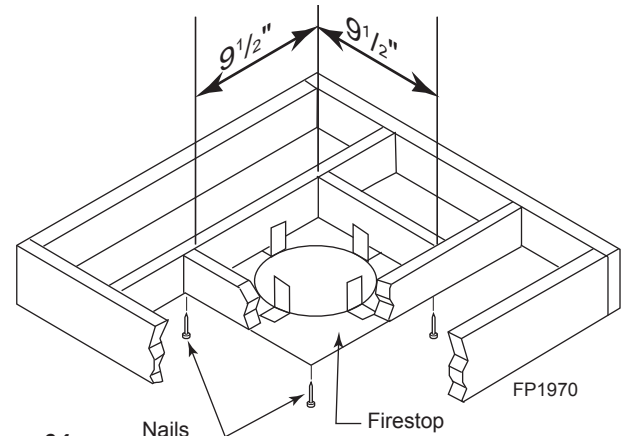


Figure 34 - If area above is not a room, install firestop below framed hole as shown

4. Connect a section of pipe and extend up through the hole.

NOTE: If an offset is needed to avoid obstructions, you must support the vent pipe every three (3) feet. Use wall straps for this purpose. Refer to Page 23, Figure 30. Whenever possible, use 45° elbows instead of 90° elbows. The 45° elbow offers less restriction to the flow of the flue gases and intake air.

5. Place the flashing over the pipe section(s) extending through the roof. Secure the base of the flashing to the roof and framing with roofing nails. Be sure roofing material overlaps the top edge of the flashing. There must be a 1" clearance from the vent pipe to combustible materials.
6. Continue to add pipe sections until the height of the vent cap meets the minimum building code requirements.

NOTE: You must increase vent height for steep roof pitches. Nearby trees, adjoining roof lines, steep pitched roofs, and other similar factors may cause poor draft or down-drafting in high winds. Increasing the vent height may solve this problem.

NOTE: If the vent pipe passes through any occupied areas above the first floor, including storage spaces and closets, you must enclose pipe. You may frame and sheetrock the enclosure with standard construction material. Make sure to meet the minimum allowable clearances to combustibles. Do not fill any of the required clearance spaces with insulation.

CHECK GAS TYPE

Use proper gas type for the fireplace you are installing. If you have conflicting gas type, do not install fireplace. See dealer where you purchased the fireplace for proper fireplace for your gas type or conversion kit.

INSTALLING GAS PIPING TO FIREPLACE / BURNER SYSTEM LOCATION

WARNING

A qualified installer or service person must connect appliance to gas supply. Follow all local codes.

CAUTION

For propane/LP units, never connect fireplace directly to the propane/LP supply. This burner system requires an external regulator (not supplied). Install the external regulator between the burner system and propane/LP supply.

INSTALLATION ITEMS NEEDED

Before installing fireplace and burner system, make sure you have the items listed below.

- External regulator (supplied by installer)
- Equipment shutoff valve*
- approved flexible gas line with gas connector (if allowed by local codes — not provided)
- Piping (check local codes)
- Test gauge connection*
- Tee joint
- Sealant (resistant to propane/LP gas)
- Sediment trap (recommended)
- Pipe wrench

* A CSA design-certified equipment shutoff valve with 1/8" NPT tap is an acceptable alternative to test gauge connection. Purchase the CSA design-certified equipment shutoff valve from your dealer.

For propane/LP connections the installer must supply an external regulator. The external regulator will reduce incoming gas pressure. You must reduce incoming gas pressure to between 11 and 13 inches of water. If you do not reduce incoming gas pressure, burner system regulator damage could occur. Install external regulator with the vent pointing down as shown in *Figure 35*. Pointing the vent down protects it from freezing rain or sleet.

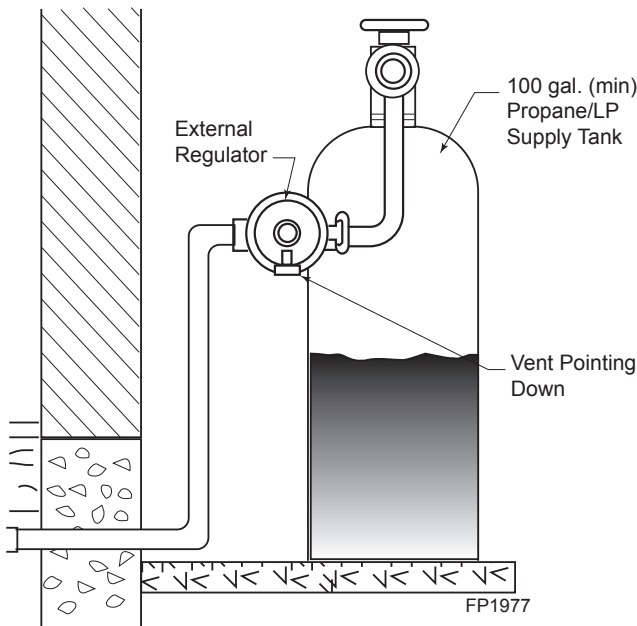


Figure 35 - External Regulator with Vent Pointing Down (Propane/LP Only)

CAUTION

Use only new black iron or steel pipe. Internally tinned copper or copper tubing can be used per National Fuel Code, Section 2.6.3, providing gas meets hydrogen sulfide limits, and where permitted by local codes. Gas piping system must be sized to provide minimum inlet pressure (listed on data plate) at the maximum flow rate (BTU/hr). Undue pressure loss will occur if the pipe is too small.

When using copper or flex connectors use only fittings approved for gas connections. The gas control inlet is 3/8" NPT.

WARNING

Only persons licensed to work with gas piping may make the necessary gas connections to this appliance.

CAUTION

A manual shutoff valve must be installed upstream of the appliance. Union tee and plugged 1/8" NPT pressure tapping point should be installed upstream of the appliance. *Figure 35*

NOTE : The gas line connection may be made using 1/2" rigid tubing or an approved flex connector. Since some municipalities have additional local codes it is always best to consult your local authorities and the current edition of the National Fuel Gas Code ANSI.Z223.1, NFPA54. In Canada CSA-B149 (1 or 2) Installation Code.

A listed manual shutoff valve must be installed upstream of the appliance. Union tee and plugged 1/8" NPT pressure tapping point should be installed upstream of the appliance. *Figure 36*

IMPORTANT: Install main gas valve (equipment shutoff valve) in an accessible location. The main gas valve is for turning on or shutting off the gas to the fireplace.

Check your building codes for any special requirements for locating equipment shutoff valve to fireplaces.

Apply pipe joint sealant lightly to male threads. This will prevent excess sealant from going into pipe. Excess sealant in pipe could result in clogged burner system valves.

CAUTION

Use pipe joint sealant that is resistant to liquid petroleum (LP) gas.

We recommend that you install a sediment trap/drip leg in supply line as shown in *Figure 36*. Locate sediment trap/drip leg where it is within reach for cleaning. Install in piping system between fuel supply and burner system. Locate sediment trap/drip leg where trapped matter is not likely to freeze. A sediment trap traps moisture and contaminants. This keeps them from going into the burner system gas controls. If sediment trap/drip leg is not installed or is installed wrong, burner system may not run properly.

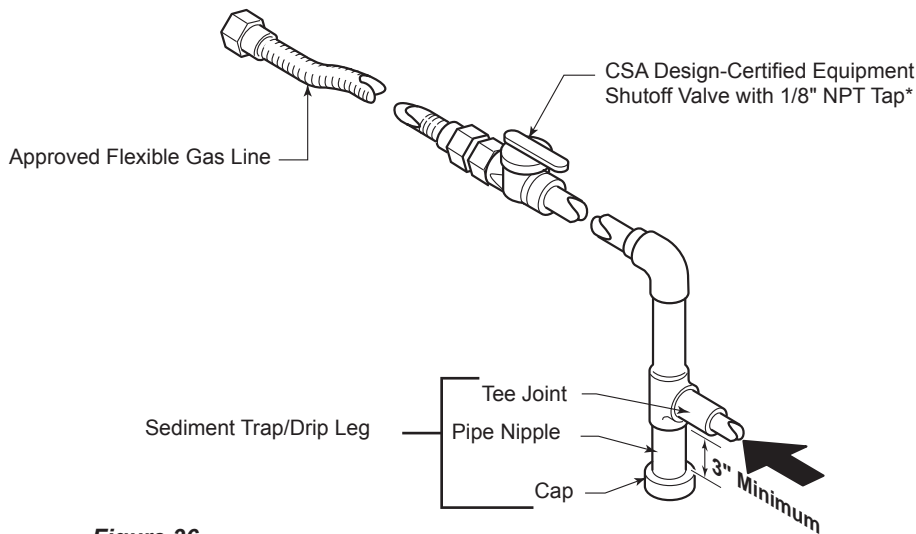
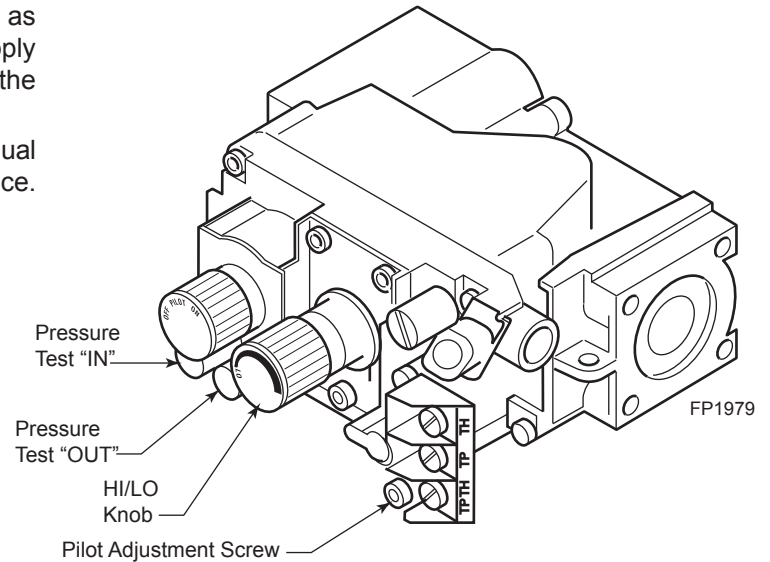


Figure 36 - Gas Connection

Natural Gas
From Gas Meter
(4.5" w.c. to 10.5" w.c. Pressure)
Propane/LP
From External Regulator
(11" w.c. to 13" w.c. Pressure)

MILLIVOLT & ELECTRONIC CHECK GAS PRESSURE and ELECTRICAL INSTALLATION

1. Check gas type. The gas supply must be the same as stated on the appliance's rating decal. If the gas supply is different from the fireplace, **STOP!** Do not install the appliance. Contact your dealer immediately.
2. To ease installation, a 30" (762 mm) flex line with manual shut-off valve has been provided with on this appliance. Install and attach 1/2" gas line onto shut-off valve.
3. After completing gas line connection, purge air from gas line and test all gas joints from the gas meter to the fireplace for leaks. Use a solution of 50/50 water and soap or a gas sniffer.
4. To adjust flame height, turn HI/LO knob to HI to get maximum pressure to burner. Turn HI/LO knob to LO to get minimum pressure.
5. To check gas pressures at valve, turn captured screw counter clockwise 2 or 3 turns and then place tubing to pressure gauge over test point. Turn unit to high. *Figure 37.* After taking pressure reading, be sure and turn captured screw clockwise firmly to reseal. Do not over torque. Check test points for gas leaks.



**Figure 37 -
Gas Pressure Check at Gas Valve**

WARNING

Do not use open flame to check for gas leaks.

ELECTRICAL WIRING

This fireplace will work without any electrical supply. Electricity is only needed to operate blower.

NOTE: If installed in mobile home, fireplace must be bolted securely to floor.

WARNING

Electrical connections should only be performed by a qualified, licensed electrician. Main power must be off when connecting to main electrical power supply or performing service. All wiring shall be in compliance with all local, city and state codes. The appliance, when installed, must be electrically grounded in accordance with local codes or in the absence of local codes, with the National Electrical Code ANSI/NFPA 70 (latest edition) and Canadian Electrical Code, CSA C22.1.

CAUTION

Label all wires before disconnecting when servicing controls. Wiring errors can cause improper and dangerous operation.

Verify proper operation after servicing.

REMOTE WALL MOUNTED SWITCH

A remote wall switch and up to fifteen (15) feet of 18 Ga. wire may be used with this appliance. Attach the wall switch in a junction box at the desired location on the wall. *Figure 38*. Do not extend beyond the wall switch wire length provided.

NOTE: Extended lengths of wire may cause the fireplace not to function properly. Longer length of wire is permitted if the wire is made out of larger gauge (diameter) wire. Always check with local code.

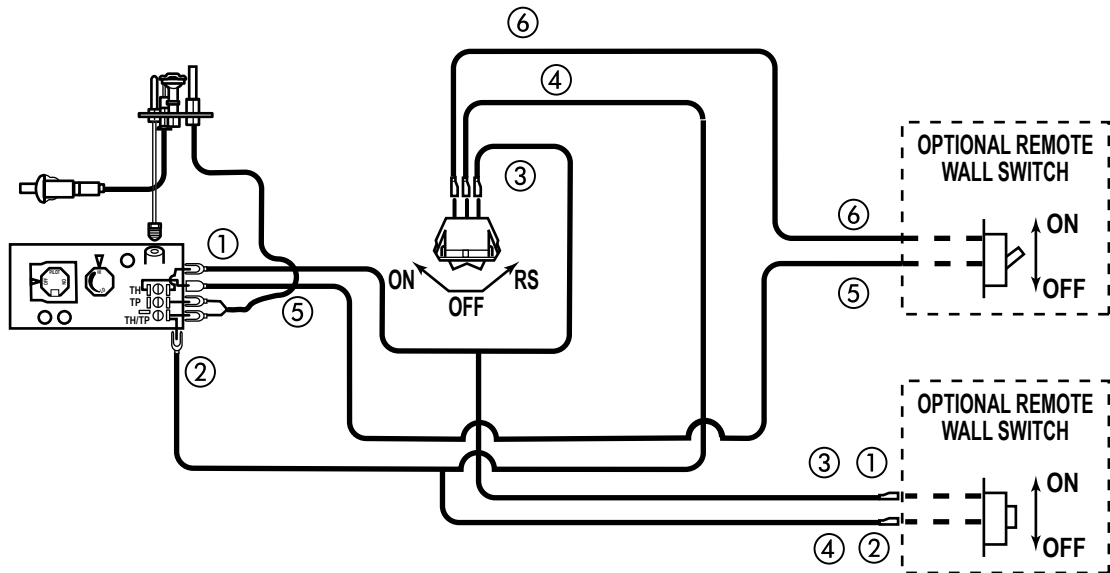


Figure 38 -
Wiring Diagram for Wall Switch

WARNING Do not connect wall switch to (110 V) circuit.

ELECTRONIC PILOT IGNITION WIRING

WARNING Do not connect 110-120V AC to the Remote Wall Switch. The appliance will malfunction.

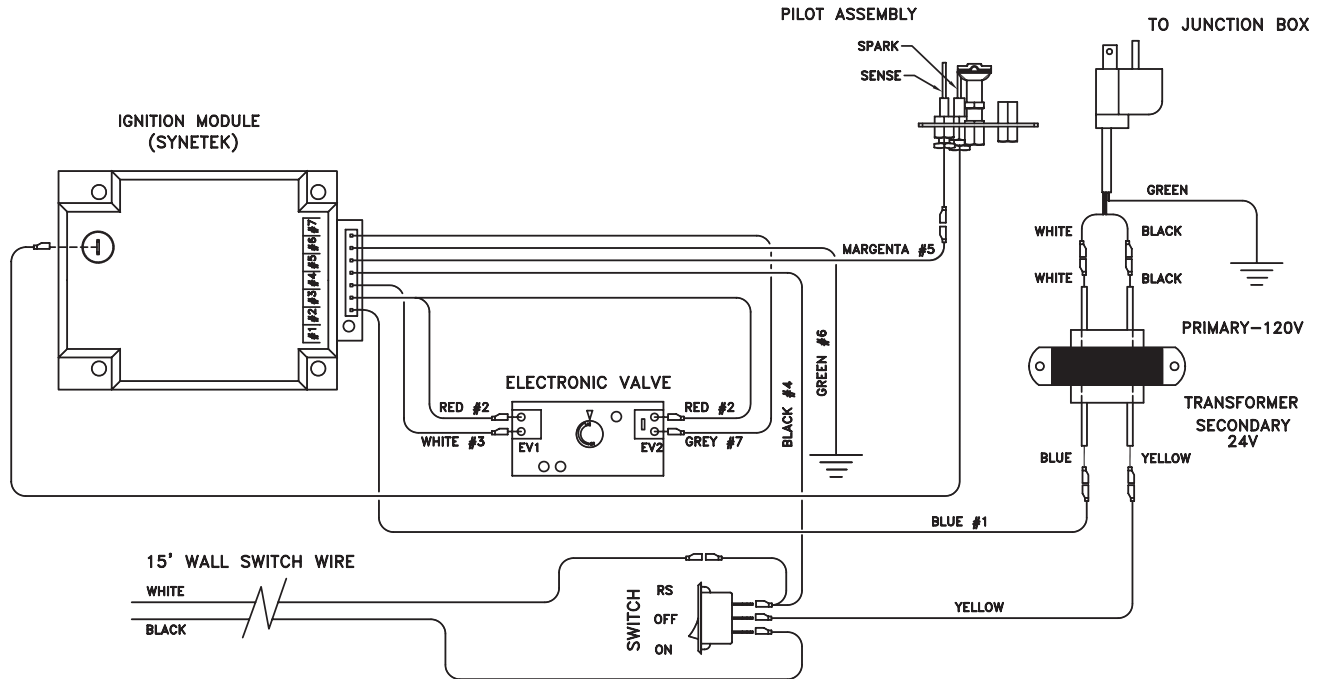


Figure 39 - Remote Wall Switch Wiring Diagram

REMOTE WALL SWITCH

Position the wall switch. Do not extend beyond the 15 feet of wire.

OPTIONAL DC REMOTE SYSTEMS

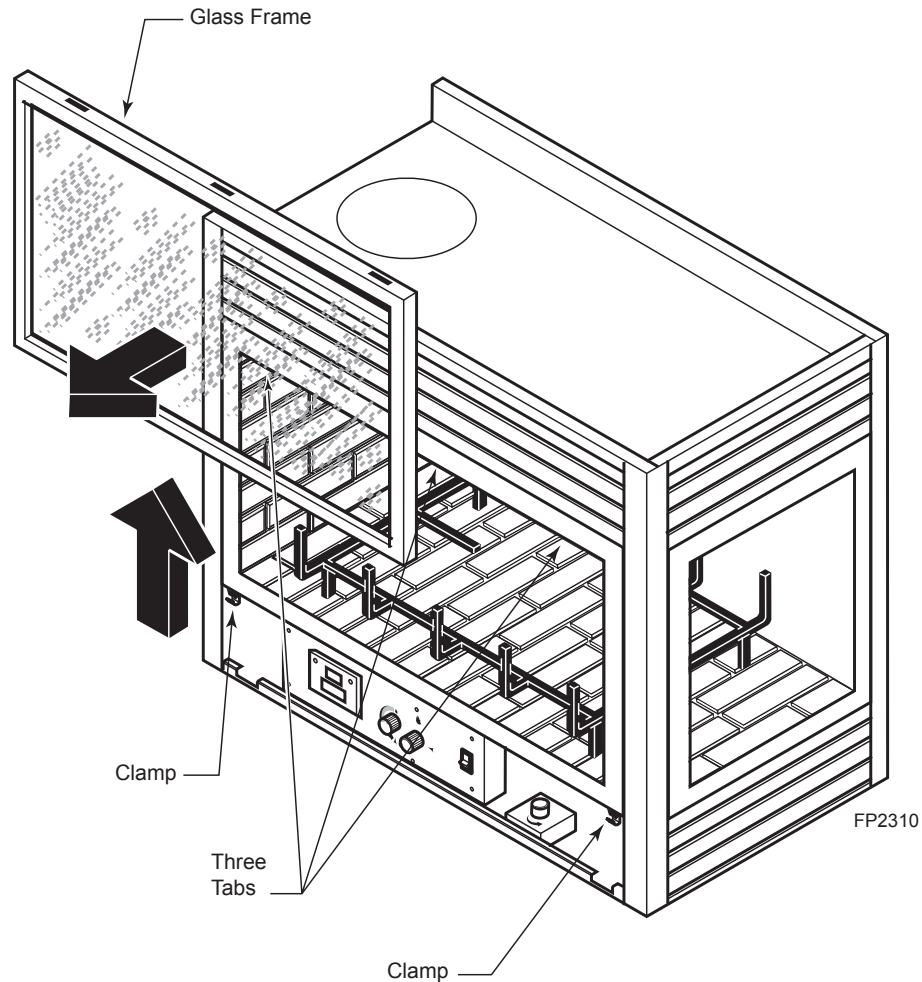
These instructions replace the section entitled *Hearth Mount* in the Millivolt hand held remote instructions supplied with the remote.

1. Plug in remote connector wire to remote receiver.
2. Connect the wire terminal from the remote receiver. This replaces the 15' wall switch connection to the switch. *Figure 39*.
3. Mount remote control receiver at junction box (for your wall switch).

GLASS FRAME REMOVAL

All three (3) glass frames are replaced the same way.

1. Release two clamps on bottom of fireplace. *Figure 40*
2. Tilt glass frame out and lift glass frame up until it clears three tabs on top of fireplace.
3. Set glass frame aside.



**Figure 40 -
Remove Glass Frame**

! WARNING



HOT GLASS WILL CAUSE BURNS.
DO NOT TOUCH GLASS UNTIL COOLED.
NEVER ALLOW CHILDREN TO TOUCH GLASS.

WARNING Each clamp has a quick spring force. When reinstalling clamps, keep fingers clear. Remove control panel to operate middle clamp on 500 and 600 units.

Before you begin — This unit is supplied with eight ceramic fiber logs. Do not handle these logs with your bare hands. **Always wear gloves to prevent skin irritation from ceramic fibers.** After handling the logs, wash your hands gently with soap and water to remove any traces of fibers.

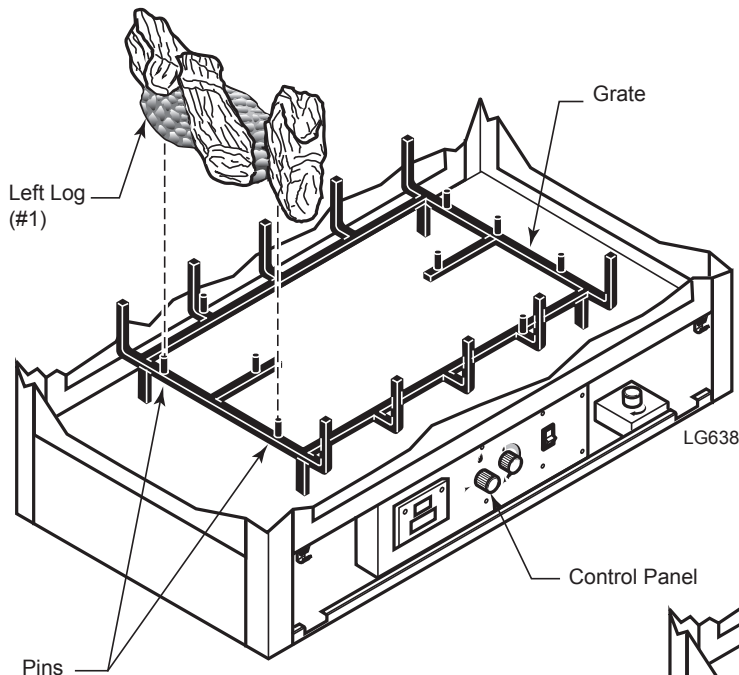
WARNING

The positioning of the logs is critical to the safe and clean operation of this heater. Excessive sooting and other problems may result if the logs are not properly and firmly positioned in the appliance. Never add additional logs or embellishments such as pine cones or vermiculite to the heater. Only use the logs supplied with the unit.

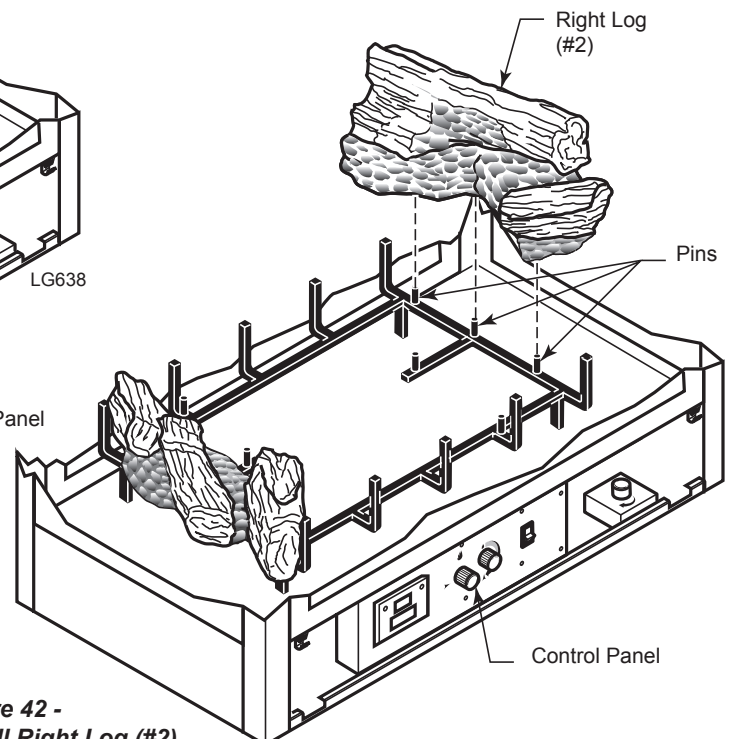
Failure to position the parts in accordance with diagrams below or to use only parts specifically approved for this heater may result in property damage or personal injury.

INSTALL LOGS AND ROCK WOOL (EMBER MATERIAL) IN FIREBOX

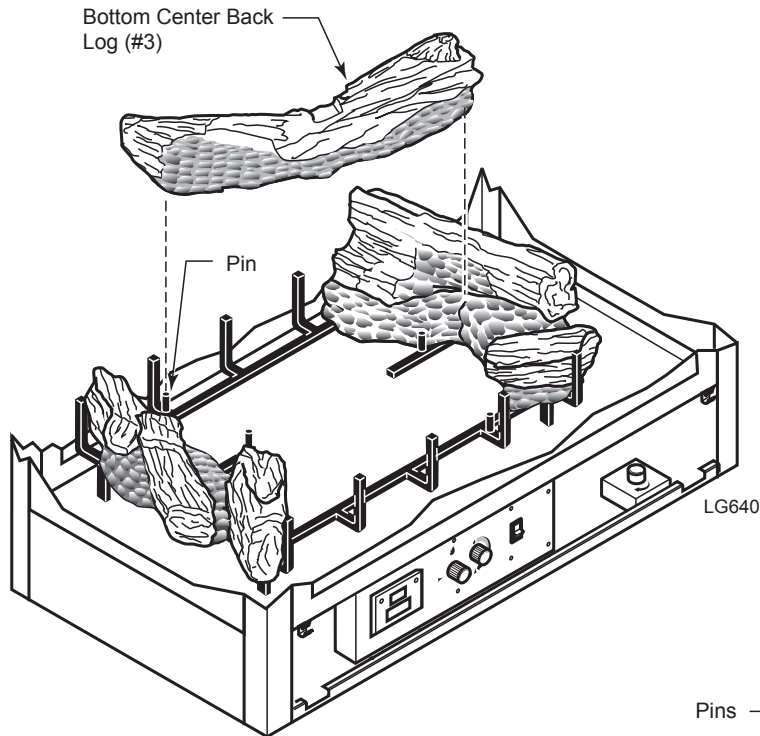
1. Remove glass frame. Refer to *Glass Frame Removal*, Page 31.
2. Carefully remove logs from wrapping.
3. Place left log (#1) on left end of grate. Line up two (2) pin holes in bottom of log with two (2) pins on grate. Log #1 will always be to the left of the control panel. *Figure 41*
4. Place right log (#2) on right end of grate. Line up three (3) pin holes in bottom of log with three (3) pins on grate. *Figure 42*



**Figure 41 -
Install Left Log (#1)**



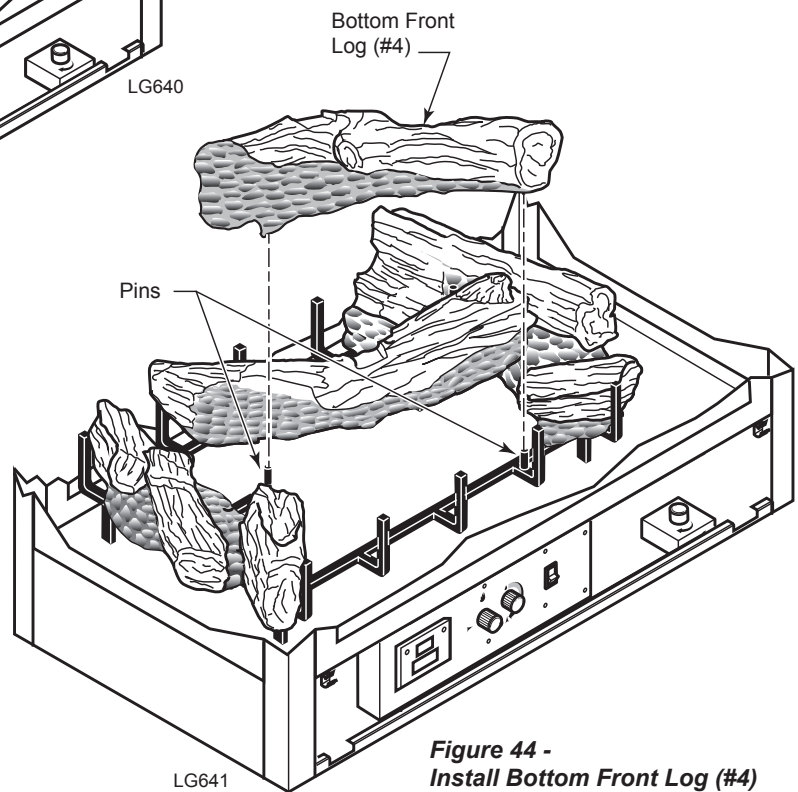
**Figure 42 -
Install Right Log (#2)**



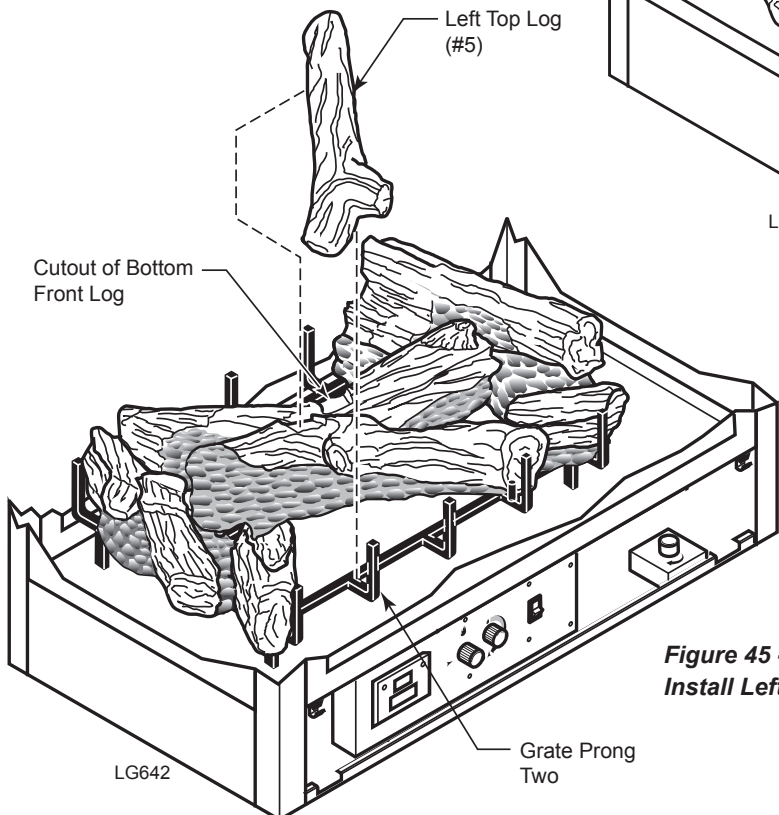
**Figure 43 -
Install Bottom Center Log (#3)**

5. Position left end of bottom center back log (#3) beside rear end of left log (#1). Line up pin on grate with pin hole in bottom of center back log (#3) Snug right end of bottom center back log (#3) to the middle of right log (#2). *Figure 43*

6. Line up pin holes on bottom front log (#4) with pins on grate. *Figure 44*

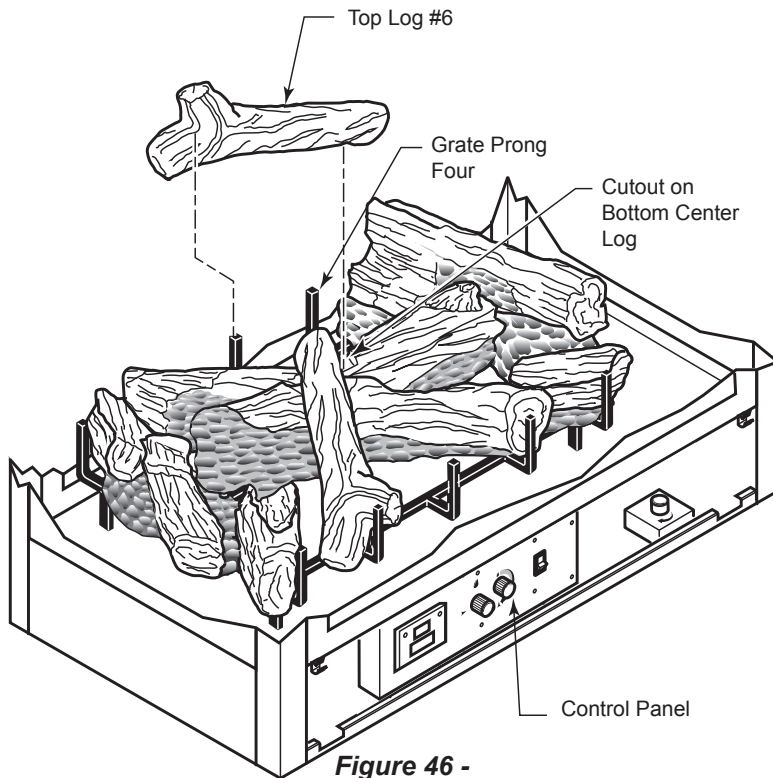


**Figure 44 -
Install Bottom Front Log (#4)**



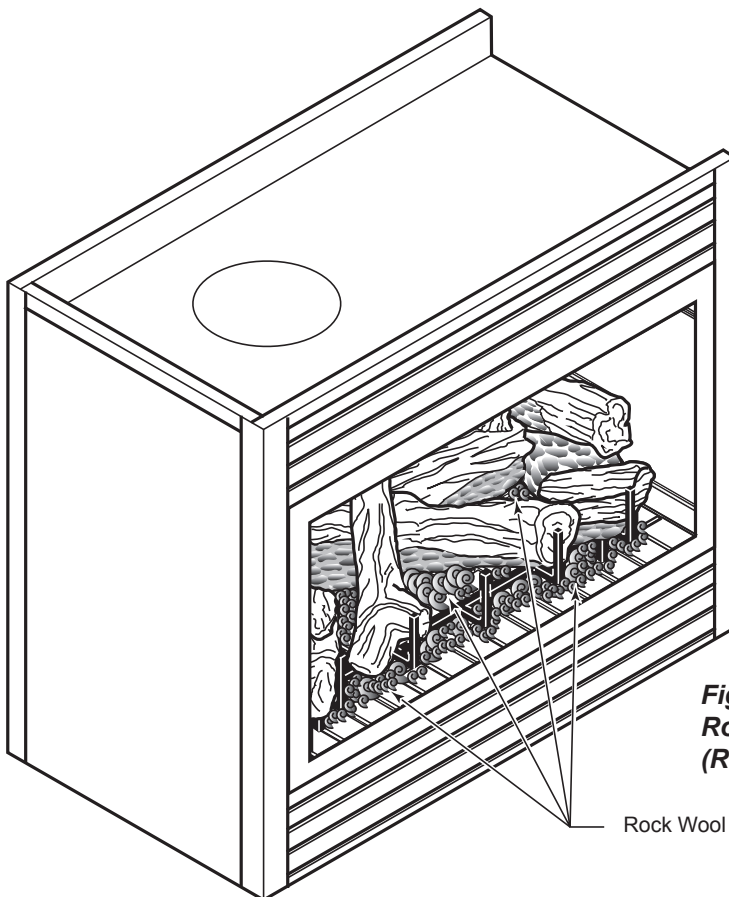
**Figure 45 -
Install Left Top Log (#5)**

7. Place back end of left top log (#5) on cutout of bottom front log (#4). Position front of left top log (#5) on grate prong two. *Figure 45*



**Figure 46 -
Install Top Log (#6)**

8. Place Y-Shaped end of top log (#6) on on prong four of back of grate. Position other end of top log (#6) in cutout of bottom center log (#3). *Figure 46*



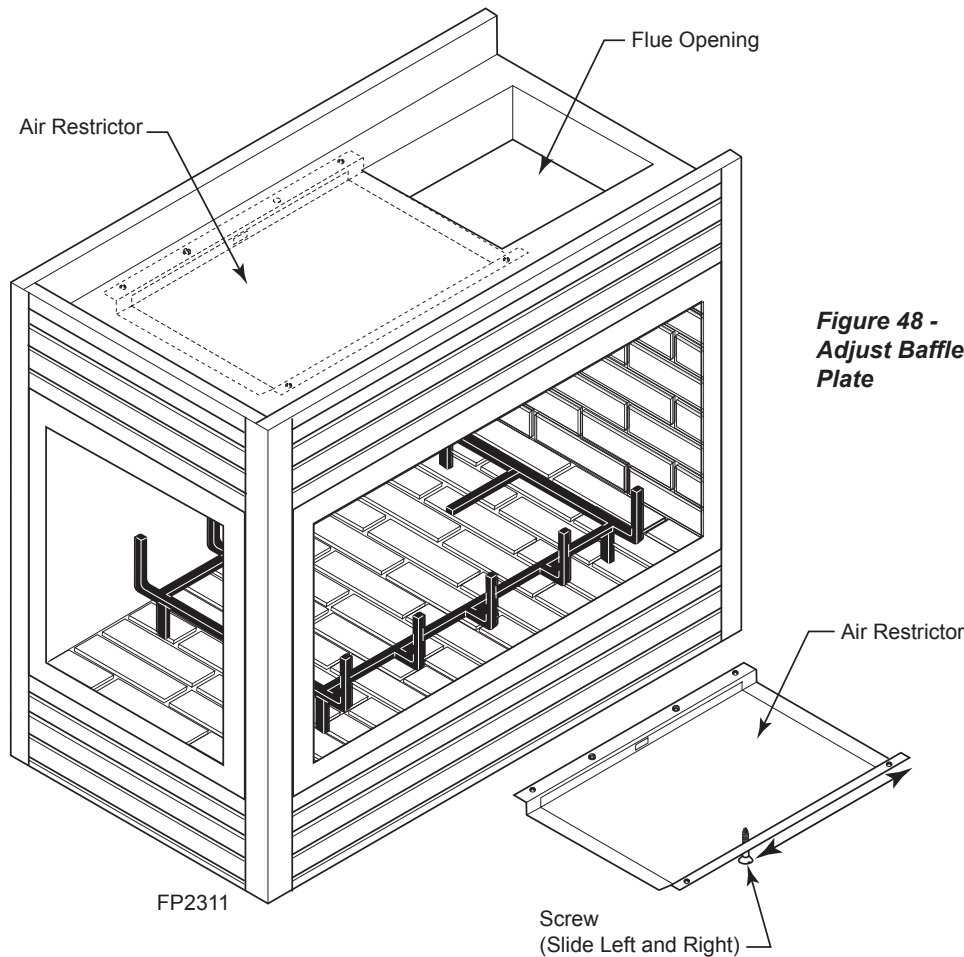
**Figure 47 -
Rock Wool Placement
(Right Corner Model Shown)**

9. Break up rock wool (ember material) into dime-sized pieces. Place evenly across burner surface and mesh of grate. *Figure 47*. Do not exceed 1" depth of coverage.

The fireplace is equipped with a restrictor plate that is located inside the top chamber of the fireplace. Depending upon the vent configuration, you may be required to adjust the restrictor position

1. Remove glass frame. Refer to *Glass Frame Removal, Page 31*.
2. Using a Phillips screw driver, loosen the screw that secures the air restrictor. Do not back the screw all the way out.
3. Slide the baffle on top of the restrictor plate to block a percentage of the grille opening. Refer to the chart below for recommended settings.

NOTE: All the settings above are based on the testing at the factory and provided as a guide for startup. On certain applications, adding a restrictor disc will help to achieve flame aesthetics.



**Figure 48 -
Adjust Baffle on Air Restrictor
Plate**

Venting Height (feet)	% of Grille Opening
8 to 20	100% (Factory Setting)
20 to 30	75%
30 to 40	50%

FOR YOUR SAFETY READ BEFORE LIGHTING**WARNING**

If you do not follow these instructions exactly, a fire or explosion may result causing property damage, personal injury or loss of life.

- A. This appliance is equipped with a pilot which must be lit with built-in battery ignitor while following these instructions exactly.
- B. BEFORE OPERATING smell all around the appliance area for gas. Be sure to smell next to the floor because some gas is heavier than air and will settle on the floor.

WHAT TO DO IF YOU SMELL GAS:

- Turn off all gas to the appliance.
 - Open windows.
 - Do not attempt to light any appliance.
 - Do not touch any electric switch; do not use any phone in your building.
 - Immediately call your gas supplier from a neighbor's phone. Follow the gas supplier's instructions.
 - If you cannot reach your gas supplier, call the fire department.
- C. Use only your hand to push in, or turn the gas control knob. Never use tools. If the knob will not push in or turn by hand, don't try to repair it. Call a qualified service technician. Force or attempted repair may result in a fire or explosion.
 - D. Do not use this appliance if any part of it has been under water. Immediately call a qualified service technician to inspect the appliance and to replace any part of the control system and any gas control that has been under water.

LIGHTING PILOT FOR THE FIRST TIME**INITIAL LIGHTING**

Purge air from the supply line as follows:

- Open main shutoff valve.
- Unscrew main pressure test point.
- Leave inlet test screw open until gas comes in.
- When gas is flowing, tighten inlet screw immediately.

WARNING

Never use an open flame to check for gas leak.

LEAK TESTING

1. Follow the pipe from the gas supply line connection to the gas valve. Check connection for leaks with soap and water mixture.
2. Next check for gas leaks at the burner with soap and water mixture.
3. Check the pilot for gas leaks with soap and water mixture.

Continued on next page

LIGHTING PILOT FOR THE FIRST TIME

APPROVED LEAK TESTING METHOD

You may check for gas leaks with the following methods only:

- Soap and water solution
- An approved leak testing spray
- Electronic sniffer

DANGER

Never check for gas leak with open flame!

WARNING

If using a soap and water solution to test for leaks, DO NOT spray solution onto control body.

NOTE: Remove any excessive pipe compound from the connections. Excessive pipe compound can set off electronic sniffers.

Check for gas leaks in each of the following locations:


- Pipe from the gas supply line connection to the gas valve
- Burner connections
- Pilot
- Each joint or connection
- Field made joints / gas shutoff valve
- Factory made joints
- All joints on valve and control body

LIGHTING PILOT

WARNING

The control has an interlock device that does not allow the lighting of the fireplace up to the moment the safety device of the flame has not interrupted the gas flow. After that period of time (when the magnet is closed), it is possible to start the lighting operation.

The gas control knob is designed to be operated by hand. **DO NOT** use any tools during this operation. Damaged knobs may result in serious injury.

1. Depress and turn knob counterclockwise  to pilot position.
2. Depress fully and hold pilot gas knob. The electronic ignitor will automatically ignite the pilot. Keep knob fully depressed for a few seconds. Release and check that pilot continues to burn.

If the pilot does not stay lit, repeat steps 1 and 2.

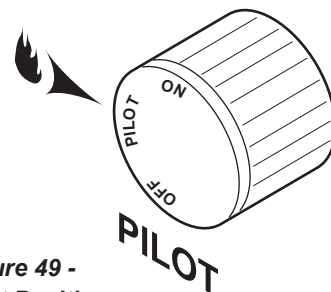


Figure 49 - Pilot Position

Continued on next page

LIGHTING BURNER

MAIN BURNER SWITCH

The “ON/OFF/RS” switch for the main burner can be found behind door of the fireplace. This switch allows you to turn on and to turn off the main burner without using the gas valve knob. Make sure the button is in the “ON” position to light the main burner. *Figure 50*

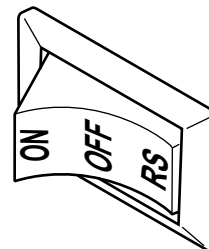


Figure 50 - On/Off/RS Switch

LIGHTING THE BURNER

Depress and turn the knob counterclockwise ↶ to the “ON” position. *Figure 51*. It will take less than four (4) seconds for the burner to ignite.

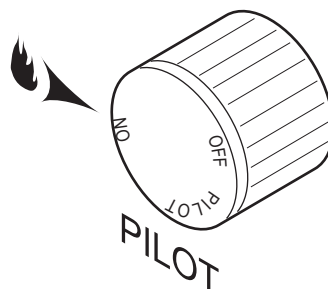


Figure 51 - On Position

PILOT POSITION

Depress and turn knob to pilot position to keep burner off while maintaining the pilot light. *Figure 52*

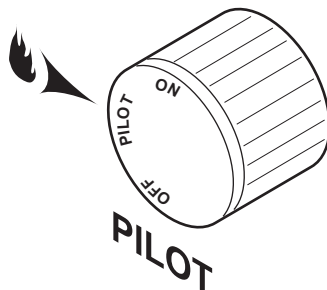


Figure 52 - Pilot Position

TO TURN OFF GAS

Depress and turn knob clockwise ↷ to “OFF” position. *Figure 53*

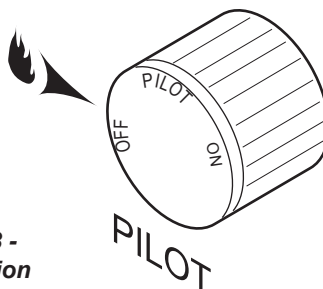


Figure 53 - Off Position

Make sure the gas valve knob is in the "OFF" position. Wait at least five (5) minutes before starting maintenance. Fireplace must be cold before starting maintenance.

VENTING SYSTEM

A qualified agency should examine the venting system annually.

CLEANING GLASS

Clean the tempered glass periodically. Condensation will sometimes form on the glass during a cold startup. This is normal for all gas fireplaces. This condensation often attracts dust and lint to the surface of the glass. The initial paint curing of the appliance can also leave a slight film on the glass.

You should clean the glass after the first two weeks of use. After that, you should clean the glass no more than two or three times a season. Use a mild glass cleaner to clean the door. Do not use abrasive cleaners. They will damage the glass surface.

CAUTION

Allow glass to cool before cleaning. Do not clean glass when it is hot. Damage could occur.

PILOT AND BURNER FLAMES

Figure 54 - Typical Burner Flame

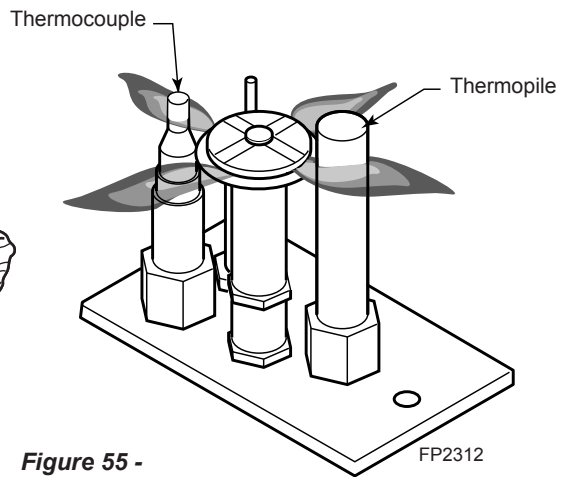
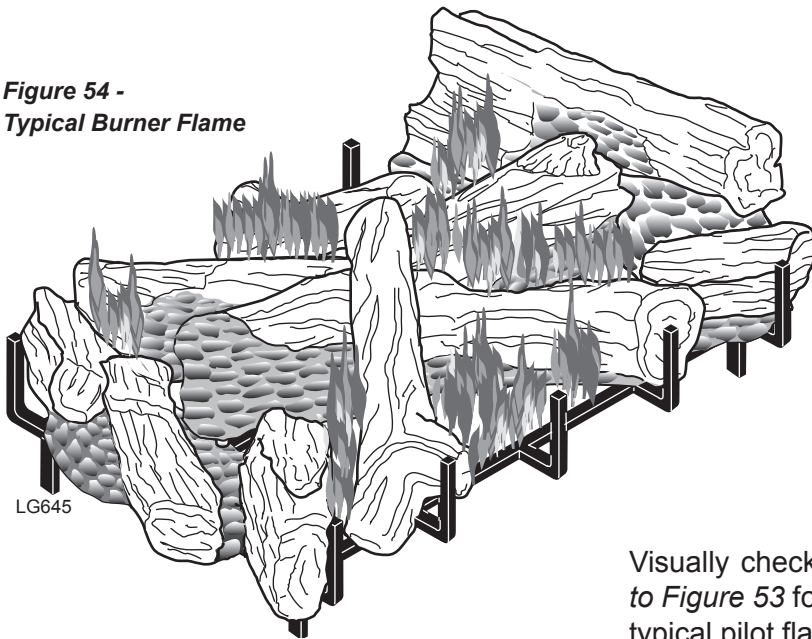


Figure 55 - Typical Pilot Flame

Visually check pilot and burner flames periodically. Refer to Figure 53 for typical burner flame. Refer to Figure 54 for typical pilot flame.

FIREBOX CLEANING

1. Carefully remove log set, and embers (rock wool) from combustion chamber.
2. Vacuum burner compartment thoroughly.
3. Vacuum or brush with soft brush any dust off logs.
4. Remove any lint from main burner and pilot.
5. Carefully replace log set, and embers in their correct positions. Refer to Pages 34 through 36.
6. Replace door (if it has been removed).
7. Relight pilot. Refer to Page 37.
8. Turn on main burner.

WARNING

Make sure clearances to combustibles leave room for maintenance and service.

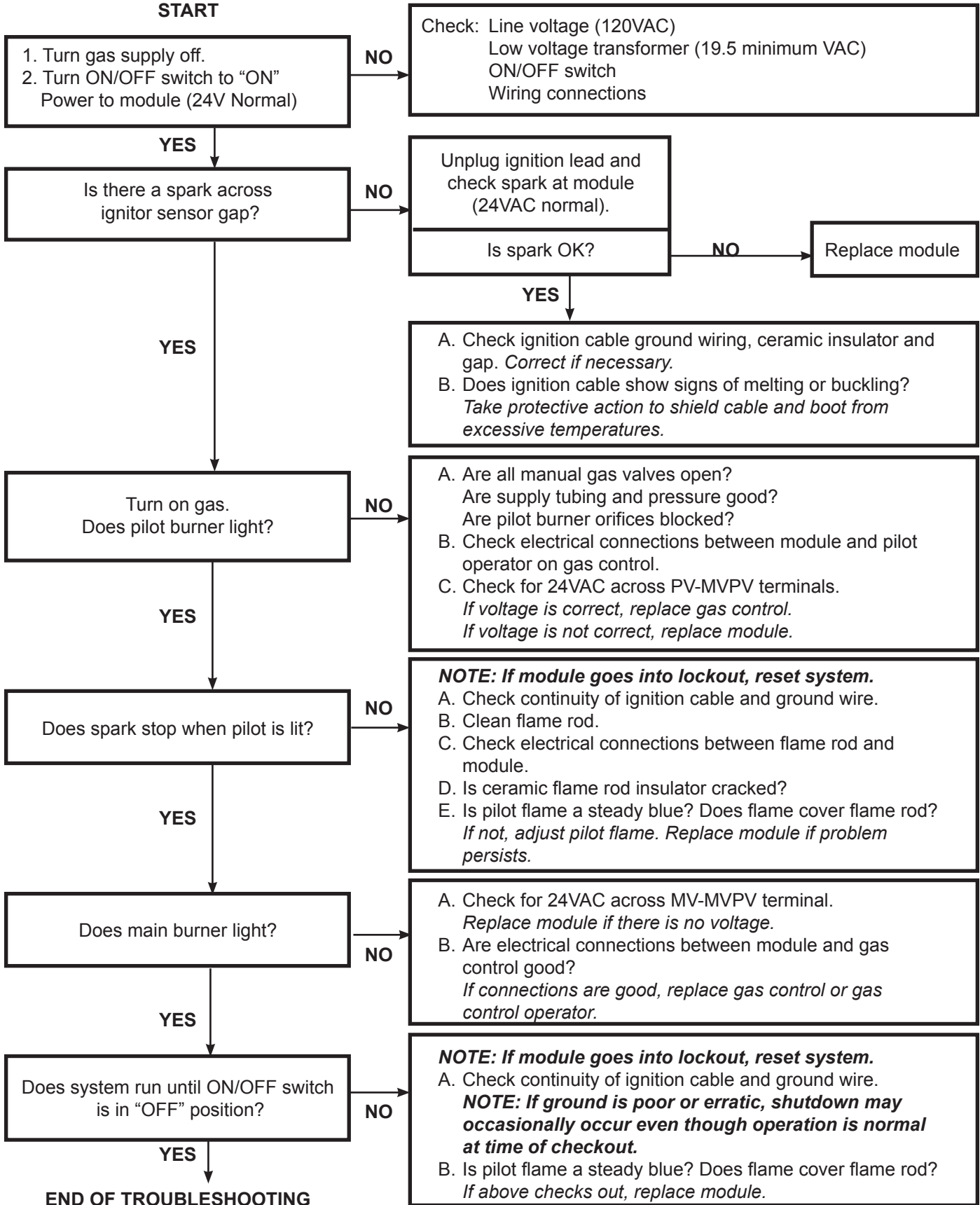
WARNING

Carefully reassemble and reseal fireplace properly after any cleaning or servicing.

STANDING PILOT IGNITION

SYMPTOM	POSSIBLE CAUSE	ACTION
1. Spark ignitor will not light pilot after repeated triggering of piezo.	A. Wire disconnected.	A. Open door and check to make sure wire is connected to ignitor.
	B. Defective ignitor.	B. Check for spark at electrode and pilot. If no spark and electrode wire is properly connected, replace pilot assembly.
	C. No gas or low gas pressure.	C. Check remote/manual shut off valve from fireplace. Low pressure can be caused by bent lines, restricted lines, low pressure line pressure. Consult with plumber or gas supplier.
	D. No Propane/LPG in tank	D. Check Propane/LPG tank. Refill tank.
2. Pilot will not stay lit after carefully following lighting instructions.	A. Defective thermocouple	A. Check that thermocouple flame impinges on thermocouple. Clean and/or adjust pilot for maximum flame impingement. Ensure that the thermocouple connection at the gas valve is fully inserted and tight. Disconnect the thermocouple from the valve, place one millivolt lead wire on the tip of the thermocouple and the other meter lead wire on the thermocouple copper lead. Start the pilot and hold the valve knob in. If the millivolt reading is less than 15 mV, replace pilot assembly.
	B. Defective valve	B. If thermocouple is producing more than 15 mV, replace faulty valve.
3. Pilot burning, valve knob turned to "ON", switch is turned to "ON" or "RS", but burner will not ignite.	A. Defective switch, wall switch, remote control or wire	A. Check switch and wire for proper connection. Place jumper wires across terminals of switch. If burner comes on, replace defective switch. If the switch is OK, repeat the same procedure on remote control. If burner comes on, replace remote control. Place jumper wire across wire at gas valves (terminals marked TH and TP/TH). If burner comes on, wires are faulty or connections are bad. Replace wire.
	B. Pilot flame too small	B. If pilot flame is not close enough to the thermopile, adjust pilot flame.
	C. Defective or malfunctioning thermopile	C. Check thermopile wire connections to make sure all are tight and that the thermopile is fully inserted into pilot assembly. Check thermopile with a millivolt meter. Connect leads to TP and TP/TH terminals on the control valve. If meter reading is below 325 mV, replace pilot assembly.
	D. Defective valve	D. Turn valve knob to "On" and switch to "ON." Take a reading at the thermopile leads (TP & TP/TH) on the valve. If the meter reads greater than 175 mV and the burner does not light, replace defective valve.

**ELECTRONIC IGNITION
START**



GENERAL TROUBLESHOOTING

SYMPTOM	POSSIBLE CAUSE	ACTION
6. Glass Soots	A. Flame impingement on logs	A. Install log set per the instructions Inspect the injector and air intake area. Make sure this area does not have any blockage from debris and clean. Check gas supply.
7. Flame burn blue and lifts off burner (ghosting)	A. Insufficient oxygen being supplied	A. Ensure that the vent cap is installed properly and free of debris. Ensure that the vent system joints are tight and have no leaks. Ensure that no debris has been blocking the inner air intake at the bottom back of the combustion chamber. Ensure that the glass is properly secure and latch.

GLASS REPLACEMENT AND BLOWER

WARNING

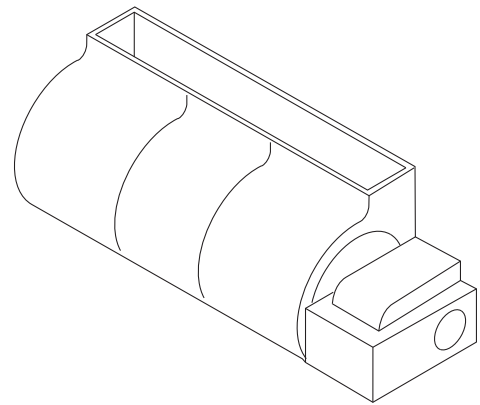
Make sure the glass panel edges do not touch any metal parts during thermal expansion.

CAUTION

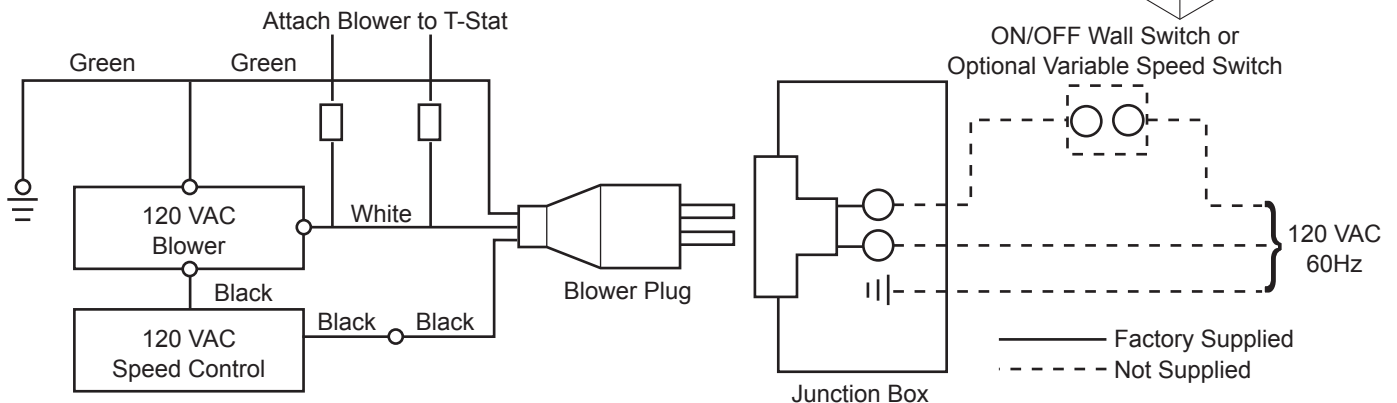
Always use gloves when handling broken glass.

- Never operate fireplace if glass is broken.
- Replace any glass that is chipped, cracked, or broken. Replacement glass assemblies **MUST** be supplied by fireplace manufacturer — **No substitute materials may be used.**

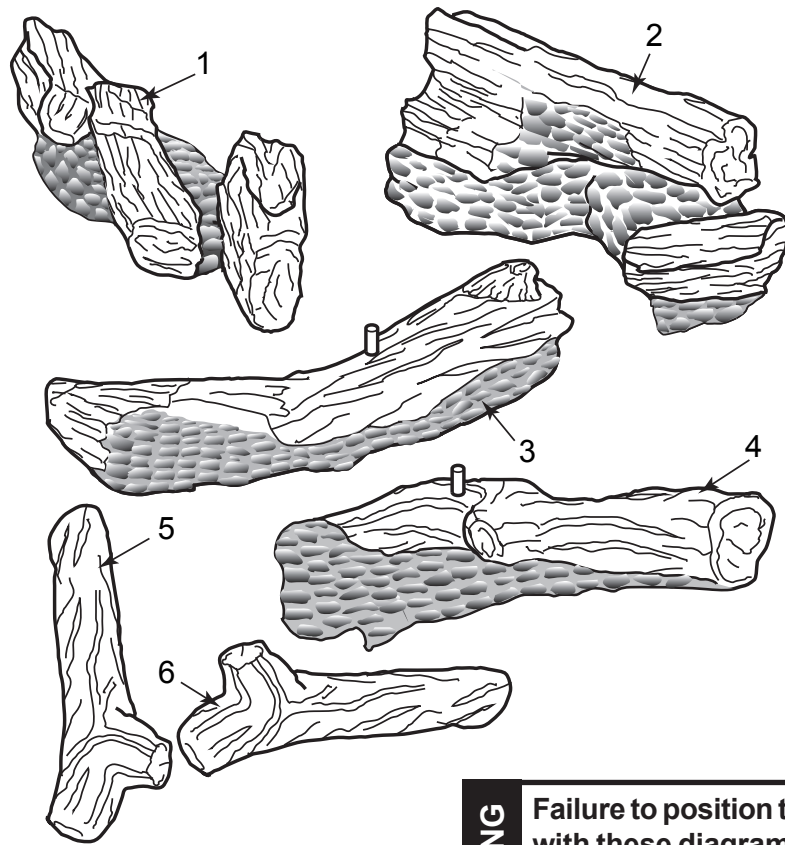
OPTIONAL BLOWER ACCESSORY - BLOT



WIRING DIAGRAM FOR BLOWER



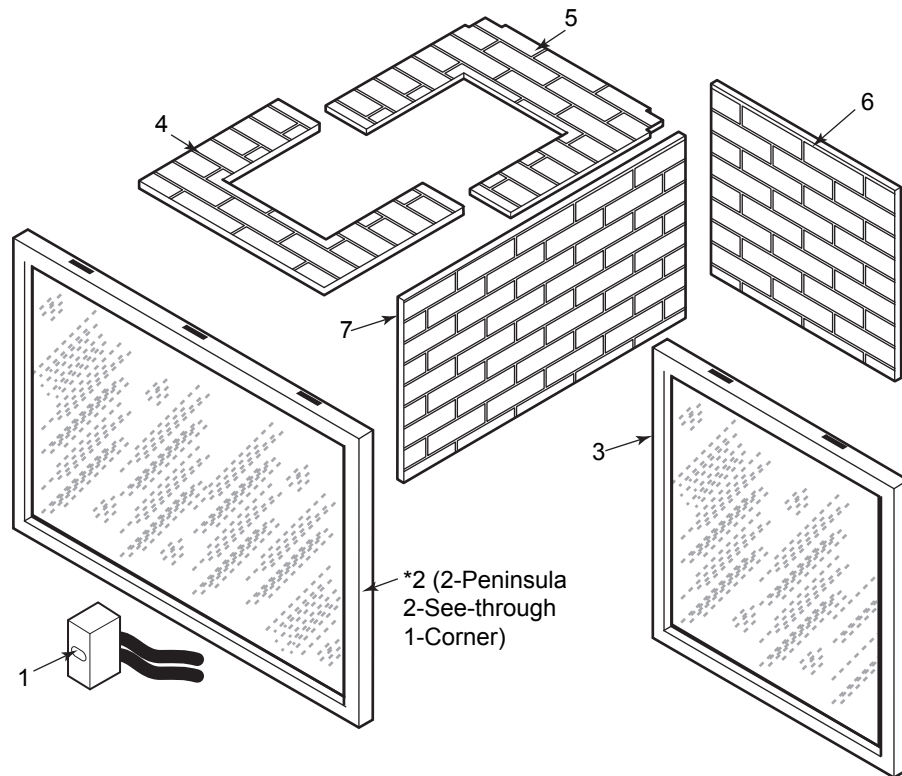
LOGS



WARNING Failure to position the parts in accordance with these diagrams or failure to use only parts specifically approved with this appliance may result in property damage or personal injury.

Ref.	Description	Qty	Natural	Propane
1.	Left Bottom Log, #1	1	42D0401	42D0401
2.	Right Bottom Log, #2	1	42D0400	42D0400
3.	Bottom Center Log, #3	1	42D0403	42D0403
4.	Bottom Front Log, #4	1	42D0402	42D0402
5.	Left Top Log, #5	1	42D0404	42D0404
6.	Top Log, #6	1	42D0405	42D0405

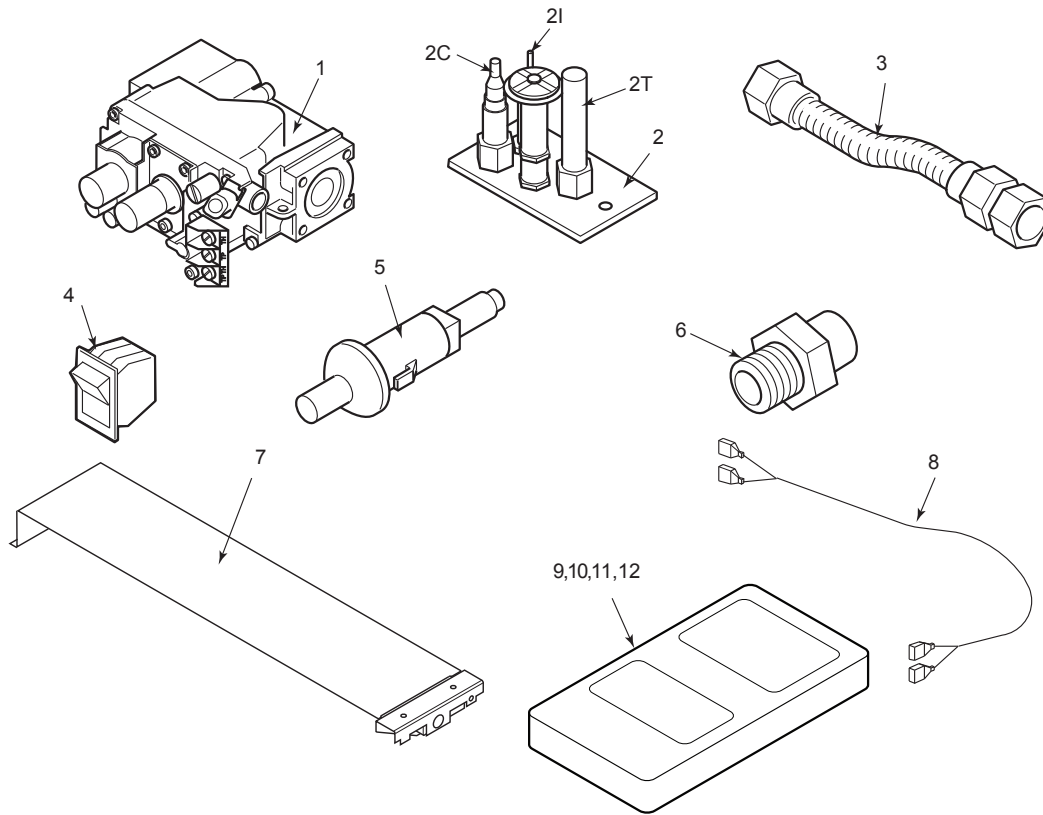
REPLACEMENT PARTS ARE AVAILABLE THROUGH YOUR RETAILER



WARNING Failure to position the parts in accordance with these diagrams or failure to use only parts specifically approved with this appliance may result in property damage or personal injury.

Ref.	Description	Qty	Natural	Propane
1.	Junction Box	1	26D2128K	26D2128K
2.	Large Glass Assy (Peninsula, See-through)	1*	42D0364K	42D0366K
2.	Large Glass Assy (Corner Left, Corner Right)	1*	42D0366K	42D0366K
3.	Small Glass Assy (Peninsula)	1	42D0365K	42D0365K
3.	Small Glass Assy (Corner Left, Corner Right)	1	42D0406K	42D0406K
4.	Small Floor Firebrick	1	26D7024	26D7124
5.	Large Floor Firebrick	1	26D7123	26D7123
6.	Small Wall Firebrick	1	26D7125	26D7125
7.	Large Wall Firebrick	1	26D7128	26D7128

STANDING PILOT – MILLIVOLT CONTROL



Ref.	Description	Qty	Natural	Propane
1.	Gas Valve Assy	1	37D0117	37D0118
2.	Pilot Assy	1	20H2048	20H2049
2C.	Replacement Thermocouple	1	37D1067	37D1067
2I.	Replacement Igniter and Wire	1	37D1069	37D1069
2T.	Replacement Thermopile	1	37D1068	37D1068
3.	Flexhose w/ Shut-off Valve	1	26D6046	23D6046
4.	Rocker Switch	1	41D0048	41D0048
5.	Piezo Igniter	1	14D0503	14D0503
6.	Injector	1	42D0502	42D0503
7.	Burner Assy	1	42D0501	42D0501
8.	Wire Assy (Female)	1	44D0500	44D0500
8.	Wire Assy (Male)	1	44D0501	44D0501
Accessories				
9.	Thermostatic Remote Control	1	RCT/TRC	RCT/TRC
10.	Remote Control On/Off	1	RCM/MRC	RCM/MRC
11.	Wall Switch Kit	1	MVWS	MVWS
12.	Wall Thermostat Kit	1	MVWTS	MVWTS

Fuel Conversion Kits - Millivolt

Natural Gas to LP

300 Conversion Kit #6000CKP

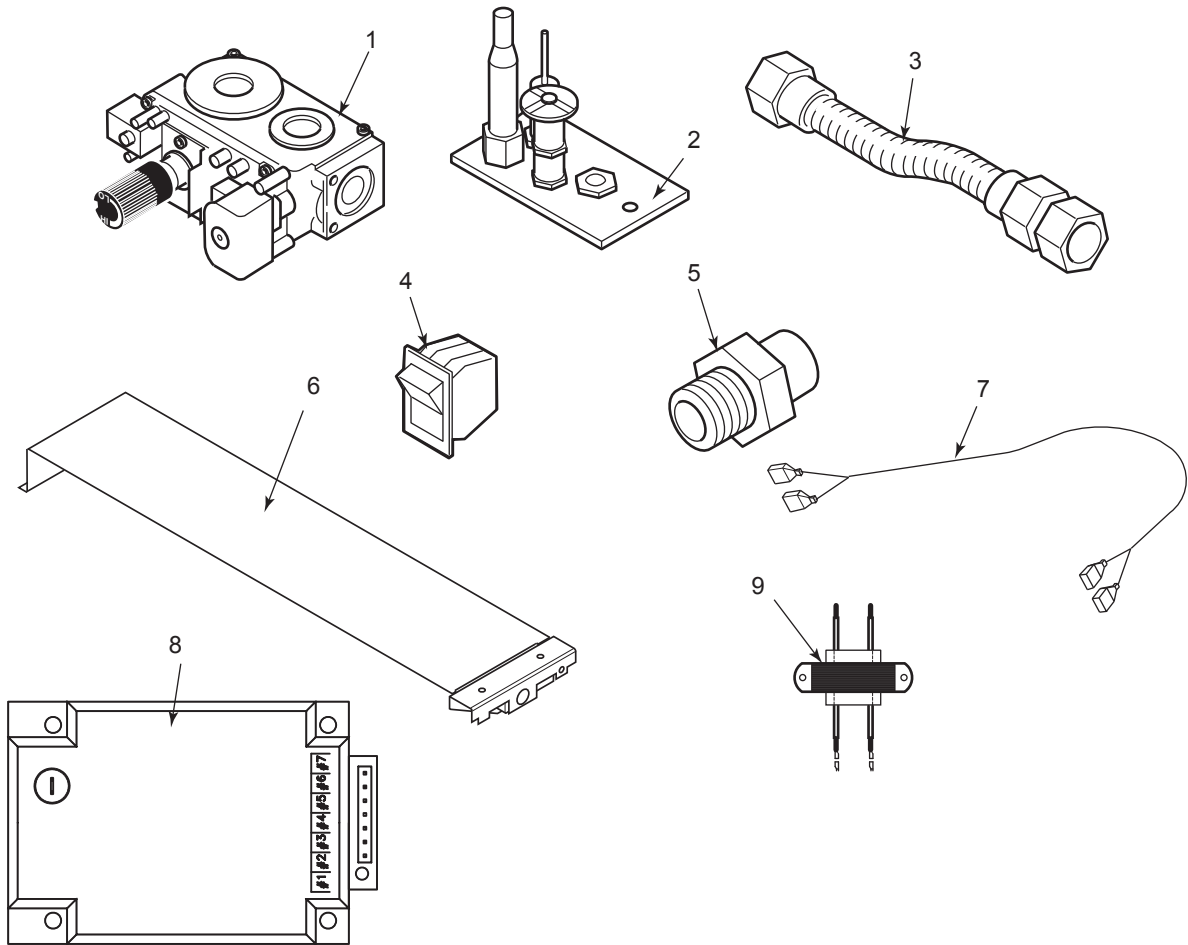
LP to Natural Gas

300 Conversion Kit #6000CKN

WARNING

Failure to position the parts in accordance with these diagrams or failure to use only parts specifically approved with this appliance may result in property damage or personal injury.

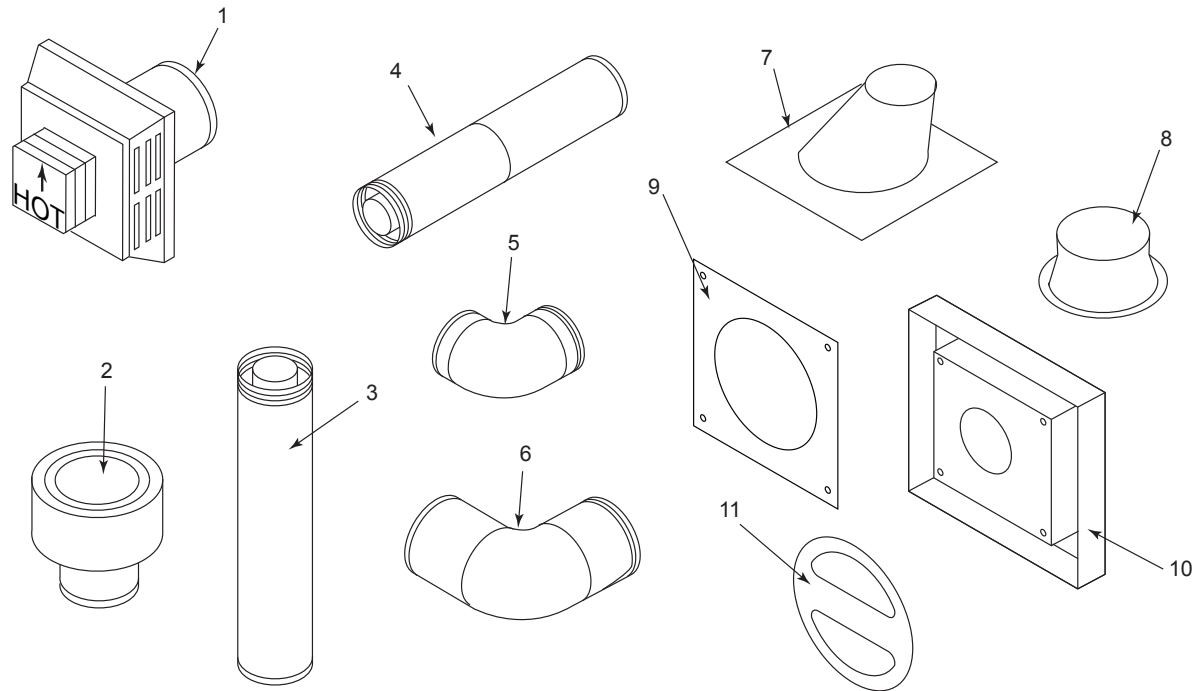
ELECTRONIC IGNITION



Ref.	Description	Qty	Natural	Propane
1.	Gas Valve Assy	1	37D0016	37D0017
2.	Pilot Assy	1	37D0020	37D0021
3.	Flexhose w/ Shut-off Valve	1	23D6046	23D6046
4.	Rocker Switch	1	41D0048	41D0048
5.	Injector	1	42D0502	42D0503
6.	Burner Assy	1	42D0500	42D0501
7.	Wire Assy	1	54D2007	54D2007
8.	Ignition Module	1	37D0325	37D0325
9.	Transformer	1	37D0027	37D0027

WARNING Failure to position the parts in accordance with these diagrams or failure to use only parts specifically approved with this appliance may result in property damage or personal injury.

VENT COMPONENTS



Ref.	Qty/Box	Description	Simpson Durvent or MHSC Pt. No.
1.	1	Simpson Horizontal High Wind Termination Horizontal Square Termination Cap w/ Built-in Vinyl Siding Standoff, Heat Deflector and Firestop	985
1.	1	Horizontal Rigid Pipe Termination Kit w/ Horizontal Termination Cap w/ Built-in Vinyl Siding Standoff, Heat Deflector, Firestop, 90° Elbow and 11" x 14 5/8" Adjustable Pipe	BHRTK BHSTK
1.	1	Horizontal Flexible Pipe Termination Kit w/ Horizontal Termination Cap w/ Built-in Vinyl Siding Standoff, Heat Deflector, Firestop, 20" to 40" Flexible Pipe Adapter	BHSFTK
2.	1	Vertical Termination	980
3.	6	6" Pipe Length	908
3.	6	9" Pipe Length	907
3.	6	12" Pipe Length	906
3.	6	24" Pipe Length	904
3.	6	36" Pipe Length	903
3.	6	48" Pipe Length	902
4.	6	11" to 14 1/2" Pipe, Adjustable	911
4.	6	17" to 24" Ppe, Adjustable	917
5.	6	45° Elbow	945
5.	6	45° Swivel Elbow	945G
6.	6	90° Elbow	990
6.	6	90° Swivel Elbow	990G
7.	6	Flashing, 0.12 to 6/12 Roof Pitch	943
8.	6	Storm Collar	953
9.	6	Firestop	963
10.	1	Vinyl Siding Standoff	950
11.	1	Restrictor Disc	45D0551

Massachusetts Residents Only — Please read and follow these special requirements

NOTE REGARDING VENTED PRODUCTS

This product must be installed by a licensed plumber or gas fitter when installed within the Commonwealth of Massachusetts.

Any residence with a direct vent product must have a CO detector installed in the residence.

Installation of the fireplace or vented gas log in the State of Massachusetts requires the damper to be permanently removed or welded in the fully open position.

In addition, a naturally vented gas log may not be installed in a bedroom or bathroom in the State of Massachusetts.

Flex line installation must not exceed 36 inches and must have a T shutoff valve.

NOTE REGARDING VENT FREE PRODUCTS

This product must be installed by a licensed plumber or gas fitter when installed within the Commonwealth of Massachusetts.

In addition, vent free products may not be installed in a bedroom or bathroom regardless of size or type in the State of Massachusetts.

Flex line installation must not exceed 36 inches and must have a T shutoff valve.

CARBON MONOXIDE DETECTOR REQUIREMENTS

(2) Revise 10.8.3 by adding the following additional requirements:

(a) For all side wall horizontally vented gas fueled equipment installed in every dwelling, building or structure used in whole or in part for residential purposes, including those owned or operated by the Commonwealth and where the side wall exhaust vent termination is less than seven (7) feet above finished grade in the area of the venting, including but not limited to decks and porches, the following requirements shall be satisfied:

1. **Installation of carbon monoxide detectors.** At the time of installation of the side wall horizontal vented gas fueled equipment, the installing plumber or gas fitter shall observe that a hard wired carbon monoxide detector with an alarm and battery back-up is installed on the floor level where the gas equipment is to be installed. In addition, the installing plumber or gas fitter shall observe that a battery operated or hard wired carbon monoxide detector with an alarm is installed on each additional level of the dwelling, building or structure served by the side wall horizontal vented gas fueled equipment. It shall be the responsibility of the property owner to secure the services of qualified licensed professionals for the installation of hard wired carbon monoxide detectors

a. In the event that the side wall horizontally vented gas fueled equipment is installed in a crawl space or an attic, the hard wired carbon monoxide detector with alarm and battery back-up may be installed on the next adjacent floor level.

b. In the event that the requirements of this subdivision can not be met at the time of completion of installation, the owner shall have a period of thirty (30) days to comply with the above requirements; provided, however, that during said thirty (30) day period, a battery operated carbon monoxide detector with an alarm shall be installed.

2. **Approved Carbon Monoxide Detectors.** Each carbon monoxide detector as required in accordance with the above provisions shall comply with NFPA 720 and be ANSI/UL 2034 listed and IAS certified.

3. **Signage.** A metal or plastic identification plate shall be permanently mounted to the exterior of the building at a minimum height of eight (8) feet above grade directly in line with the exhaust vent terminal for the horizontally vented gas fueled heating appliance or equipment. The sign shall read, in print size no less than one-half (1/2) inch in size, "GAS VENT DIRECTLY BELOW. KEEP CLEAR OF ALL OBSTRUCTIONS."

4. **Inspection.** The state or local gas inspector of the side wall horizontally vented gas fueled equipment shall not approve the installation unless, upon inspection, the inspector observes carbon monoxide detectors and signage installed in accordance with the provisions of 248 CMR 5.08(2)(a)1 through 4.

(b) **Exemptions:** The following equipment is exempt from 248 CMR 5.08(2)(a)1 through 4:

1. The equipment listed in Chapter 10 entitled "Equipment Not Required To Be Vented" in the most current edition of NFPA 54 as adopted by the Board; and

2. Product Approved side wall horizontally vented gas fueled equipment installed in a room or structure separate from the dwelling, building or structure used in whole or in part for residential purposes.

(c) **Manufacturer requirements — Gas Equipment Venting System Provided.** When the manufacturer of Product Approved side wall horizontally vented gas equipment provides a venting system design or venting system components with the equipment, the instructions provided by the manufacturer for installation of the equipment and the venting system shall include:

1. Detailed instructions for the installation of the venting system design or the venting system components; and
2. A complete parts list for the venting system design or venting system.

(d) **Manufacturer requirements — Gas Equipment Venting System Not Provided.** When the manufacturer of a Product Approved side wall horizontally vented gas fueled equipment does not provide the parts for venting the flue gases, but identifies "special venting systems," the following requirements shall be satisfied by the manufacturer:

1. The referenced "special venting system" instructions shall be included with the appliance or equipment installation instructions; and

2. The "special venting systems" shall be Product Approved by the Board, and the instructions for that system shall include a parts list and detailed installation instructions.

(e) A copy of all installation instructions for all Product Approved side wall horizontally vented gas fueled equipment, all venting instructions, all parts lists for venting instructions, and/or all venting design

LIMITED LIFETIME WARRANTY POLICY

LIFETIME WARRANTY

The following components are warranted for life to the original owner, subject to proof of purchase: Firebox, Combustion Chamber, Heat Exchanger, Grate and Stainless Steel Burners.

FIVE YEAR WARRANTY

The following components are warranted five (5) years to the original owner, subject of proof of purchase: Ceramic Fiber Logs.

BASIC WARRANTY

MHSC warrants the components and materials in your gas appliance to be free from manufacturing and material defects for a period of two years from date of installation. After installation, if any of the components manufactured by MHSC in the appliance are found to be defective in materials or workmanship, MHSC will, at its option, replace or repair the defective components at no charge to the original owner. MHSC will also pay for reasonable labor costs incurred in replacing or repairing such components for a period of two years from date of installation. Any products presented for warranty repair must be accompanied by a dated proof of purchase.

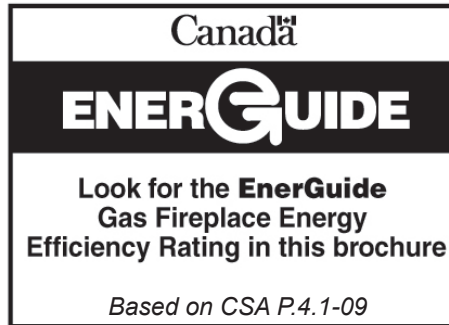
This Limited Lifetime Warranty will be void if the appliance is not installed by a qualified installer in accordance with the installation instructions. The Limited Lifetime Warranty will also be void if the appliance is not operated and maintained according to the operating instructions supplied with the appliance, and does not extend to (1) firebox/burner assembly damage by accident, neglect, misuse, abuse, alterations, negligence of others, including the installation thereof by unqualified installers, (2) the costs of removal, reinstallation or transportation of defective parts on the appliance, or (3) incidental or consequential damage. All service work must be performed by an authorized service representative.

This warranty is expressly in lieu of other warranties, express or implied, including the warranty of merchantability of fitness for purpose and of all other obligations or liabilities. MHSC does not assume for it any other obligations or liabilities in connection with sale or use of the appliance. It states that do not allow limitations on how long an implied warranty lasts, or do not allow exclusion of indirect damage, those limitations of exclusions may not apply to you. You may also have additional rights not covered in the Limited Lifetime Warranty.

MHSC reserves the right to investigate any and all the claims against the Limited Lifetime Warranty and decide upon method of settlement.

IF WARRANTY SERVICE IS NEEDED...

1. Contact your supplier. Make sure you have your warranty, your sales receipt and the model/serial number of your MHSC product.
2. DO NOT ATTEMPT TO DO ANY SERVICE WORK YOURSELF.



Efficiency Ratings	
Model	EnerGuide Ratings Fireplace Efficiency (%)
624DVSTNVC	62.8
624DVPFNVC	62.8
624DVCRNVC	62.8
624DVCLNVC	62.8
624DVSTPVC	70.6
624DVFPVC	70.6
624DVCRPVC	70.6
624DVCLPVC	70.6
624DVSTNEC	65.1
624DVPFNEC	65.1
624DVCRNEC	65.1
624DVCLNEC	65.1
624DVSTPEC	73.4
624DVFPPEC	73.4
624DVCRPEC	73.4
624DVCLPEC	73.4

MHSC

149 Cleveland Drive • Paris, Kentucky 40361
www.mhsc.com