

This Owner's Manual is provided and hosted by [Appliance Factory Parts](http://ApplianceFactoryParts.com).



# Monessen Hearth GFCC42NV Owner's Manual

[Shop genuine replacement parts for Monessen Hearth  
GFCC42NV](#)



[Find Your Monessen Hearth Fireplace Parts - Select From 701 Models](#)

----- Manual continues below part list -----

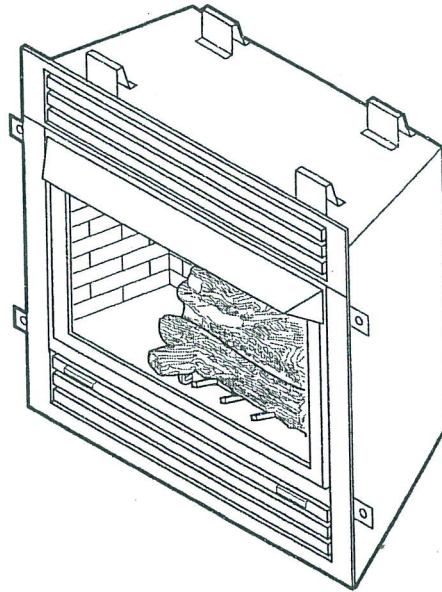
## Available Replacement Parts for Monessen Hearth GFCC42NV

<a href="#">14D0467</a>	VALVE MV NG (060656)+
<a href="#">SRV00K0632</a>	ASSY-WIRE
<a href="#">SRV18D0603</a>	KNOB-REMOTE-(MILLI-VOLT)

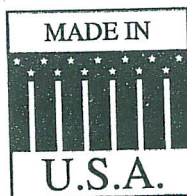
# VENT-FREE FIREPLACE SYSTEMS

## INSTALLATION AND OPERATING INSTRUCTIONS

MODELS
DFCC32, GFCC32
DFCC36, GFCC36
DFCC42, GFCC42
Natural Gas or Propane/LPG
Manual or Millivolt Control



CIRCULATING SERIES



This is an unvented gas-fired heater. It uses air (oxygen) from the room in which it is installed. Provisions for adequate combustion and ventilation air must be provided. *Refer to page 7*

### WARNINGS

If the information in this manual is not followed exactly, a fire or explosion may result causing property damage, personal injury or loss of life.

- Do not store or use gasoline or other flammable vapors and liquids in the vicinity of this or any other appliance.
- **WHAT TO DO IF YOU SMELL GAS**
  - Do not try to light any appliance.
  - Do not touch any electrical switch; do not use any phone in your building.
  - Immediately call your gas supplier from a neighbor's phone. Follow the gas supplier's instructions.
  - If you cannot reach your gas supplier, call the fire department.
- Installation and service must be performed by a qualified installer, service agency or the gas supplier.

**READ AND SAVE THESE INSTRUCTIONS**

## CONTENTS

---

IMPORTANT SAFETY INFORMATION .....	1
PRODUCT FEATURES .....	3
PRODUCT FEATURES / SPECIFICATIONS .....	4
GETTING STARTED .....	5
GENERAL INSTALLATION INFORMATION .....	6
LOCATION OF FIREPLACE .....	11
CLEARANCE AND HEIGHT REQUIREMENTS .....	12
FIREPLACE FRAMING .....	14
CONNECTING THE GAS .....	16
CHECKING GAS PRESSURE .....	17
ELECTRICAL WIRING .....	18
LOG PLACEMENT .....	19
FLAME APPEARANCE .....	20
CHECKING BURNER FLAMES .....	21
OPERATING INSTRUCTIONS .....	21
WHAT TO DO IF YOU SMELL GAS .....	22
MANUAL CONTROL LIGHTING .....	23
MILLIVOLT CONTROL LIGHTING .....	24
MATCH LIGHTING INSTRUCTIONS .....	25
CLEANING AND SERVICING .....	25
BLOWER AND OTHER OPTIONAL EQUIPMENT .....	26
PARTS LIST .....	27, 28, 30
ILLUSTRATION .....	27, 29, 30
TROUBLESHOOTING .....	32, 33

---

## IMPORTANT SAFETY INFORMATION

### INSTALLER

Please leave these instructions with the owner.

### OWNER

Please retain these instructions for future reference.

#### IMPORTANT

Read these instructions carefully before installing or trying to operate this vent-free gas heater.

#### WARNING

- Any change to this heater or its controls can be dangerous.
- Improper installation or use of the heater can cause serious injury or death from fire, burns, explosion or carbon monoxide poisoning.
- Do not allow fans to blow directly into the fireplace. Avoid drafts that alter burner flame patterns.
- Do not use a blower insert, heat exchanger insert or other accessory, not approved for use with this heater.

1. Due to high temperatures, the heater should be located out of traffic and away from furniture and draperies.
2. Children and adults should be alerted to the hazard of high surface temperature and should stay away to avoid burns or clothing ignition.
3. Young children should be carefully supervised when they are in the same room with the heater
4. Do not place clothing or other flammable material near the fireplace when the heater is in use.
5. Any safety screen or guard removed for servicing, must be replaced prior to operating the heater.
6. Installation and repair should be done by a qualified service person.
7. To prevent malfunction and/or sooting, an unvented gas heater should be cleaned at least annually by a professional service person. More frequent cleaning may be required due to excessive lint from carpeting, etc. It is imperative that control compartments, burners and circulating air passageways be kept clean.

8. **CARBON MONOXIDE POISONING:** Early signs of carbon monoxide poisoning are similar to the flu with headaches, dizziness and/or nausea. If you have these signs, obtain fresh air immediately. Have the heater serviced as it may not be operating properly.

9. The installation must conform with local codes or, in the absence of local codes, with the National Fuel Gas Code, ANSI Z223.1.
10. This unit complies with ANSI Z21.11.2a-1997 Unvented Heaters and also complies with ANSI Z26.60-1991 Decorative Vented Appliances for Solid Fuel Burning Fireplaces. State and local codes may only allow operation of this appliance in a vented configuration. Check your state or local codes. For vented operation, see "Vented Instructions" in this manual.
11. Do not install the heaters in a bathroom or bedroom.
12. Correct installation of the ceramic fiber logs, proper location of the heater and annual cleaning are necessary to avoid potential problems with sooting. Sooting, resulting from improper installation or operation, can settle on surfaces outside the fireplace. See log placement instructions for proper installation.
13. Avoid any drafts that alter burner flame patterns. Do not allow fans to blow directly into fireplace. Do not place a blower inside burn area of firebox. Ceiling fans may create drafts that alter burner flame patterns. Sooting and improper burning will occur.
14. This is an unvented gas-fired heater. It uses air (oxygen) from the room in which it is installed. Provisions for adequate combustion and ventilation air must be provided. Refer to installation guidelines.

## IMPORTANT SAFETY INFORMATION

---

15. Keep room area clear and free from combustible materials, gasoline and other flammable vapors and liquids.
16. Unvented gas heaters are a supplemental zone heater. They are not intended to be a primary heating appliance. Water vapor produced by an unvented heater can create moisture problems in a home when operated for extended periods of time.
17. During manufacturing, fabricating and shipping, various components of this appliance are treated with certain oils, films or bonding agents. These chemicals are not harmful but may produce annoying smoke and smells as they are burned off during the initial operation of the appliance; possibly causing headaches or eye or lung irritation. This is a normal and temporary occurrence.

The initial break-in operation should last 2-3 hours with the burner at the highest setting. Provide maximum ventilation by opening windows or doors to allow odors to dissipate. Any odors remaining after this initial break-in period will be slight and will disappear with continued use.
18. Input ratings are shown in BTU per hour and are for elevations up to 2,000 feet. For elevations above 2,000 feet, input ratings should be reduced 4 percent for each 1,000 feet above sea level. Refer to the National Fuel Gas Code.
19. The heater and its individual shutoff valve must be disconnected from the gas supply piping system during any pressure testing of that system at test pressures in excess of 1/2 psig (3.5 kPa).
20. The heater must be isolated from the gas supply piping system by closing its individual manual shutoff valve during any pressure testing of the gas supply piping system at test pressures equal to or less than 1/2 psig (3.5 kPa).
21. Do not use this room heater if any part has been under water. Immediately call a qualified service technician to inspect the room heater and to replace any part of the control system and any gas control which has been under water.
22. This appliance must not be used with glass doors in the closed position. This can lead to pilot outages and severe sooting outside the fireplace.
23. Never burn solid fuels in a fireplace where a unvented room heater is installed.
24. Always have a fireplace screen in place when the appliance is in operation and, unless other provisions for combustion air are provided, the screen shall have an opening(s) for induction of combustion air.

**This appliance may be installed in an aftermarket, permanently located, manufactured (mobile) home, where not prohibited by local codes.**

**This appliance is only for use with the type of gas indicated on the rating plate. This appliance is not convertible for use with other gases.**



*Figure 1. Unvented Gas Heater  
(Control Access Door Shown Open)*

Your vent-free fireplace must be mounted on the floor or on the optional fireplace hearth.

**OPERATION**

This unvented gas heater requires no outside venting, burns cleanly with high heating efficiency.

This zero-clearance unvented gas heater can be installed against (or recessed into) any wall that is accessible to a gas line.

## PRODUCT FEATURES/SPECIFICATIONS

### Natural Gas

#### Manual Pressure

Regulator Pressure Setting: 3" w.c.

Gas Inlet Pressure: Max. 10 1/2" w.c.  
Min. 5" w.c.

#### Millivolt Pressure

Regulator Pressure Setting: 3.5" w.c.

Pilot Regulator: 3.5" w.c.

Gas Inlet Pressure: Max. 10 1/2" w.c.  
Min. 5" w.c.

Model Number	Control	Gas Rate	
		Max.	Min.
(DFCC/GFCC)32NM	Manual	25,000	13,000
(DFCC/GFCC)32NV	Millivolt	24,000	14,000
(DFCC/GFCC)36NM	Manual	27,000	14,000
(DFCC/GFCC)36NV	Millivolt	27,000	18,000
(DFCC/GFCC)42NM	Manual	27,000	14,000
(DFCC/GFCC)42NV	Millivolt	27,000	18,000

### Propane / LPG

*Note: An external regulator is required to reduce supply pressure to a maximum of 13" w. c.*

#### Manual Pressure

Regulator Pressure Setting: 10" w.c.

Gas Inlet Pressure: Maximum 13" w.c.  
Minimum 11" w.c.

#### Millivolt Pressure

Regulator Pressure Setting: 10" w.c.

Gas Inlet Pressure: Maximum 13" w.c.  
Minimum 11" w.c.

Model Number	Control	Gas Rate	
		Max.	Min.
(DFCC/GFCC)32PM	Manual	20,000	10,000
(DFCC/GFCC)32PV	Millivolt	24,000	16,000
(DFCC/GFCC)36PM	Manual	26,000	13,000
(DFCC/GFCC)36PV	Millivolt	26,000	19,000
(DFCC/GFCC)42PM	Manual	26,000	13,000
(DFCC/GFCC)42PV	Millivolt	26,000	19,000

**Ignition** - Piezo ignitor allows ignition of the pilot without the use of matches or batteries.  
**Controls**

*Manual control has four (4) positions:*

- OFF** - All gas to the gas logs is shut off at the valve.
- IGN** - Valve position to light/maintain a standing pilot.
- LOW** - Minimum gas rate: Front burner provides a realistic glow on the center log.
- HI** - Maximum gas rate: Front burner provides a realistic glow on the center log, plus the rear burner provides a pleasing yellow flame.

*Millivolt control has four (4) positions:*

- OFF** - All gas to the gas logs is shut off at the valve.
- IGN** - Valve position to light/maintain a standing pilot.
- ON** - Valve position to turn ON/OFF log set with remote switch/thermostat.
- LOW/HI** - Variable position to control flame height (heat output). Both front and rear burners are in operation to provide realistic glow and yellow flame.

## PRODUCT SPECIFICATIONS /GETTING STARTED

---

**Pilot** - The gas log heater is fitted with a specially designed safety pilot light which senses the amount of oxygen available in the room and shuts the gas log heater off if the oxygen level begins to drop below a satisfactory level. The pilot can only be relit when adequate fresh air is available.

**Thermal Generator** - The millivolt gas log pilot is fitted with a millivolt generator to provide power for remote activation.

### GETTING STARTED

**Make sure you have received all parts:**

Check your packing list to verify that all listed parts have been received. You should have the following:

- Unvented gas heater.
- Installation / operating instructions.
- Ceramic fiber logs.
- Two (2) anchoring screws.
- Plastic bag containing crushed volcanic rock.
- Canopy and five (5) mounting screws.

Millivolt controlled heater designed to be operated with optional devices for ON/OFF functions.

- Hand held Remote with receiver.
- Wall switch with 20' wire.
- Wall T-stat with 20' wire.
- Hand held Thermostats Remote w/ receiver.

**CAUTION**

**Handle the gas log burner assembly by the grate only. Do not pick the unit up by the burners.**

**Gloves are recommended when handling ceramic fiber logs to prevent skin irritation from loose fibers. Logs are fragile -- handle with care.**

Carefully inspect the contents for shipping damage. If any parts are missing or damaged, immediately inform the dealer from whom you purchased the appliance. **Do not attempt to install any part of the appliance unless you have all parts in good condition.**

#### **What you will need for installation:**

You must have the following items available before proceeding with installation:

- External regulator (for propane / L.P.G. only)
- Piping which complies with local codes
- Pipe sealant approved for use with propane / L.P.G. (Resistant to sulfur compounds)
- Manual shutoff valve
- Sediment trap
- Tee joint
- Pipe wrench
- Phillips head screwdriver

## GENERAL INSTALLATION INFORMATION

In planning the installation for the fireplace it is necessary to determine where the unit is to be installed and whether optional accessories are desired. Gas supply piping should also be planned. The following steps represent the normal sequence of installation. Each installation is unique, however, and might require a different sequence.

1. Position fireplace in desired location. Refer to the "Location of Fireplace" and "Clearances / Height Requirements", and "Firebox Framing" sections found in this manual. *Note: Be sure all packing material has been removed from underside the unit.*
2. Install canopy and logs per instructions found in this manual. The canopy **MUST** be installed for safe operation of the unit.
3. Field wire main power supply to units with fan kit. Refer to the "Electrical Section" found in this manual. (Electrical connections should only be performed by an experienced, licensed certified tradesman).
4. Install optional ON/OFF kit on units with millivolt control. Refer to installation instructions included with the kit and also refer to the "Electrical Wiring" section found in this manual.
5. Plumb gas line. refer to the "Connecting the Gas" section found in this manual. (Gas connections should only be performed by an experienced, licensed / certified tradesman).
6. Complete finish wall material and/or surround.

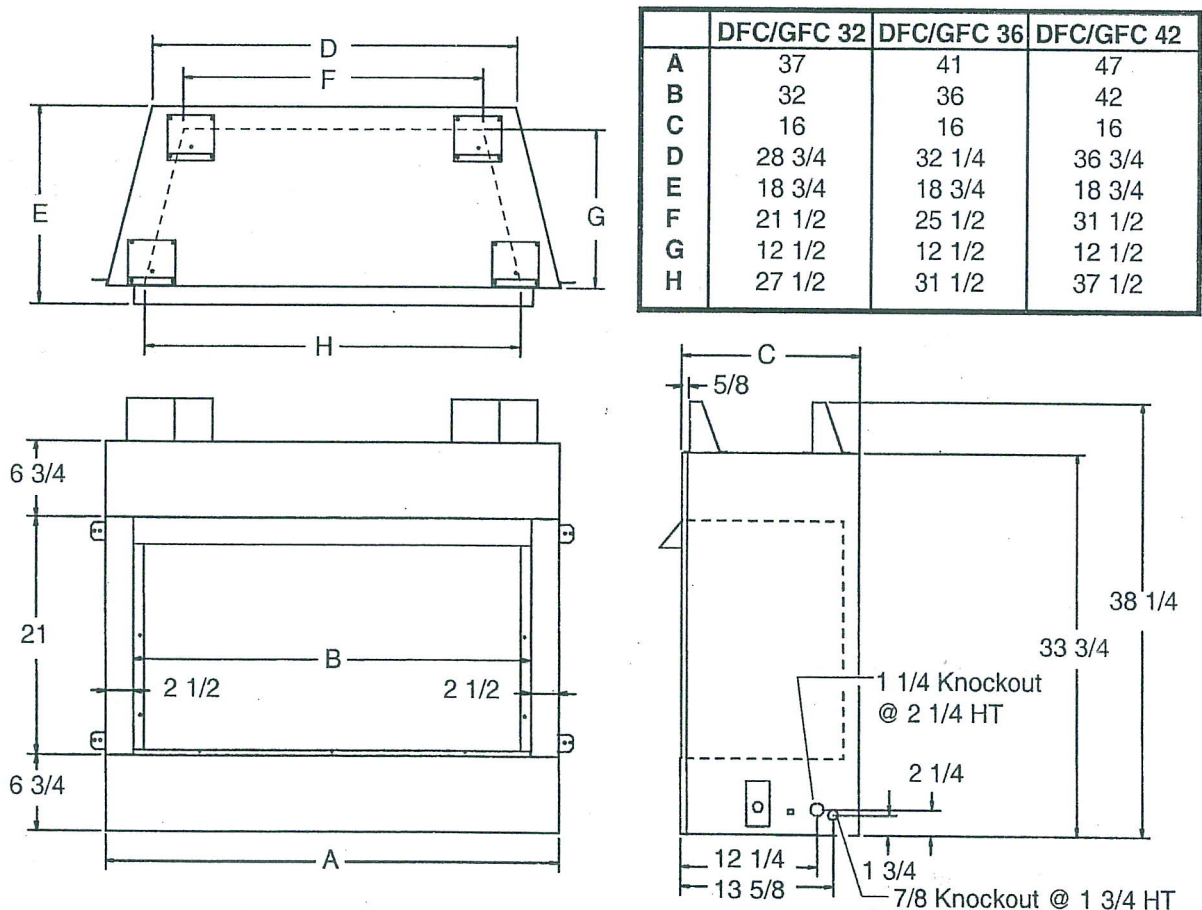


Figure 2. Firebox Dimensions with Glass Panel and Log Sets Removed

## GENERAL INSTALLATION INFORMATION

### CODES

Adhere to all local codes or, in their absence, the latest edition of THE NATIONAL FUEL GAS CODE ANSI Z223.1 or NFPA54 which can be obtained from:

**American National Standards Institute, Inc.**

1430 Broadway  
New York, NY 10018

or

**National Fire Protection Association, Inc.**

Batterymarch Park  
Quincy, MA 02269

### WARNING

**Do not install the heater:**

- Where curtains, furniture, clothing, or other flammable objects are less than 42" from the front of the heater.
- In high traffic areas.
- In windy or drafty areas.

### ADEQUATE COMBUSTION AND VENTILATION AIR

This heater shall not be installed in a confined space or unusually tight construction unless provisions are provided for adequate combustion and ventilation air.

The National Fuel Gas Code ANSI Z223.1 defines a confined space as a space whose volume is less than 50 cubic feet per 1,000 BTU per hour, ( $4.8 \text{ m}^3$  per kw) of the aggregate input rating of all appliances installed in that space and an unconfined space is defined as a space whose volume is not less than 50 cubic feet per 1,000 BTU per hour ( $4.8 \text{ m}^3$  per kw) of the aggregate input rating of all appliances installed in that space. Rooms communicating directly with the space in which the appliances are installed, through openings not furnished with doors, are considered a part of the unconfined space.

**Unusually tight construction is defined as construction where:**

- a) Walls and ceilings exposed to the outside atmosphere have a continuous water vapor retarder with a rating of 1 perm ( $6 \times 10^{-11} \text{ kg per-pa-sec-m}^2$ ) or less with openings gasketed or sealed, and
- b) Weather stripping has been added on openable windows and doors, and
- c) Caulking or sealant are applied to areas such as joints around windows and door frames, between sole plates and doors, between wall-ceiling joints, between wall panels, at penetrations for plumbing, electrical, and gas lines, and at other openings.

## GENERAL INSTALLATION INFORMATION



The following formula can be used to determine the maximum heater rating per the definition of unconfined space:

*Combustion Air*

$$\text{BTU/HR} = \frac{(L1 + L2) \text{ Ft} \times (W) \text{ Ft} \times (H) \text{ Ft} \times 1000}{50}$$

Consider two connecting rooms with an open area between, with the following dimensions:  
 L1 = 15 1/2 Ft., L2 = 12 Ft., W = 12 Ft., H = 8 Ft.

$$\begin{aligned} \text{BTU/HR} &= \frac{(15 \frac{1}{2} + 12) \times (12) \times (8) \times 1000}{50} \\ &= 52800 \text{ BTU/HR} \end{aligned}$$

If there were a door between the two rooms the calculation would be based only on the room with the heater.

$$\begin{aligned} \text{BTU/HR} &= \frac{(15 \frac{1}{2}) \times (12) \times (8) \times 1000}{50} \\ &= 29760 \text{ BTU/HR} \end{aligned}$$

### WARNING

If the area in which the heater may be operated is smaller than that defined as an unconfined space or if the building is of unusually tight construction, provide adequate combustion and ventilation air by one of the methods described in the National Fuel Gas Code, ANSI Z223.1, Section 5.3 or applicable local codes.

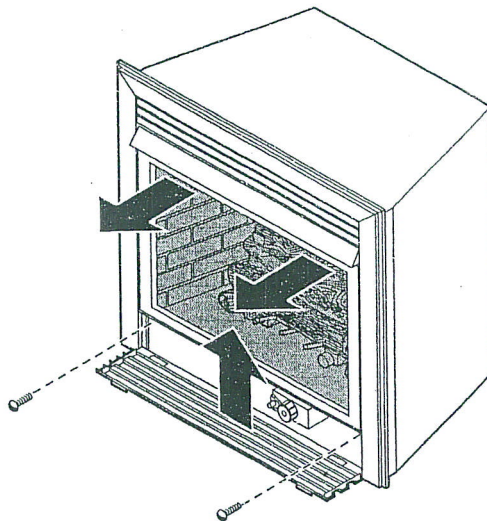
## GENERAL INSTALLATION INFORMATION

### REMOVING SCREEN

Removing fireplace glass frame panel by removing two screws on either side and pushing glass frame panel up and out. *See figure 3*

**WARNING**

Do not operate the unit without the glass frame panel or canopy installed.



*Figure 3. Removing Fireplace Glass Frame Panel*

*NOTE: Screen frame must be removed to access log box and to install canopy.*

### INSTALLING CANOPY

1. Remove the screen frame panel as described in the previous section.
2. Align the black canopy with the holes in the top frame assembly. *Refer to Figure 4*
3. Install the three (3) screws which attach the canopy to the top frame assembly. Install the two (2) screws which attach to the side frame. *Refer to Figure 4*
4. Tighten all screws, make sure the canopy is level and secure. Install the screen frame panel.



*Figure 4. Canopy Installation*

## GENERAL INSTALLATION INFORMATION

---

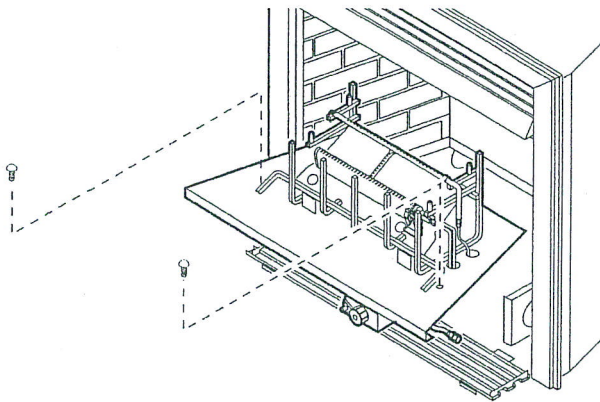
### SECURING HEATER TO FLOOR OR HEARTH

*Note: Clearance requirements as detailed in "Clearances/Height Requirements" section, of this manual, must be met before securing the heater in place.*

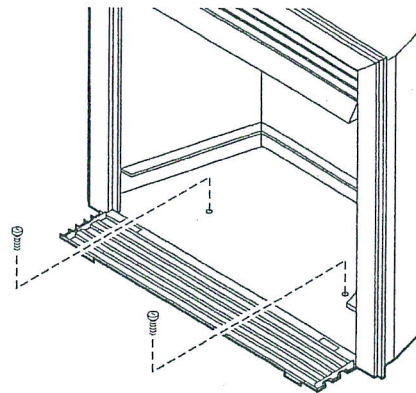
To prevent movement, the heater must be secured to the floor or hearth.

- Open the control access door and remove the glass frame.
- Remove carton containing the four-log set.
- To remove the grate and base assembly, take out five (5) screws as shown in *Figure 6*.
- Lift grate and base assembly out of the firebox. (**CAUTION: Lift grate and base assembly using the grate only.**)
- Secure the firebox with two anchoring screws (3/16" x 1 1/4" length) supplied with the fireplace system. Refer to *Figure 7*.

*Note: If the unit is mounted on carpeting, tile or combustible material without the hearth, a metal or wooden base covering the entire width and depth of the base must be installed.*



*Figure 6*



*Figure 7. Securing Heater to Floor or Hearth*

## LOCATION OF FIREPLACE

---

Carefully select the best location for installation of your unvented fireplace. The following factors should be taken into consideration.

- Clearance to side wall, ceiling, woodwork and window or other combustibles. Refer to **Clearances / Height Requirements** section on page 12. Minimum clearances to combustibles **must be maintained**.
- Location must not be affected by drafts caused by kitchen exhaust fans, ceiling fans, return air registers for forced air furnaces / air conditioners, windows or doors.
- Installation must provide adequate ventilation and combustion air.
- **DO NOT INSTALL THIS FIREPLACE IN A BEDROOM OR BATHROOM.**
- Location should be out of high traffic areas and away from furniture and draperies due to heat from firebox.
- Never obstruct the front opening of the unvented fireplace or restrict the flow of combustion and ventilation air.
- Minimize modifications to existing construction. *Refer to Figure 8* below for location suggestions.
- Do not install in the vicinity where gasoline or other flammable liquids may be stored. The unvented firebox must be kept clear and free from the combustible materials.



*Figure 8*

## CLEARANCES / HEIGHT REQUIREMENTS

Ensure that minimum clearances shown in *Figure 9 through 10* are maintained. Left and right clearances are determined when facing the front of the firebox.

Follow these instructions carefully to ensure safe installation. Failure to follow these requirements may create a fire hazard.

1. **Sidewall clearances:** the clearance from the inside of the appliance to any combustible wall should not be less than 9" (*refer to Figure 9*).
2. **Ceiling clearance:** The ceiling must be at least 42" from the top of the firebox opening (*refer to Figure 9*).
3. **Back wall clearance:** The appliance may be placed against a combustible back wall.
4. **Floor clearance:** The fireplace may not be installed onto any combustible flooring material, such as carpeting, vinyl or tile without the hearth or a min. 22 Ga (0.030") metal or a min. 1/2" wooden base covering the entire width and depth of the base. The specified clearance shall be maintained 1/2" from top surface of carpeting, tile, etc.



*Figure 9*

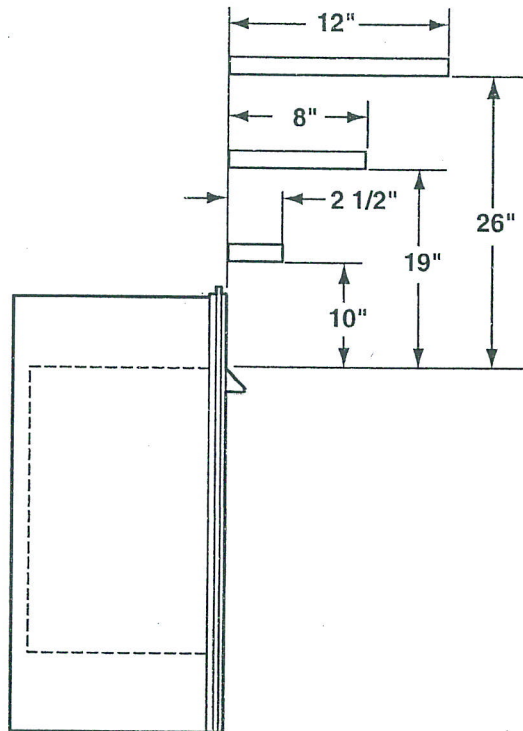
**WARNING**

The dimensions shown in Figures 9-10 are minimum clearances to maintain in installing this heater. Left and right clearances are determined when facing the front of the heater.

Follow these instructions carefully to ensure safe installation. Failure to follow instructions exactly can create a fire hazard.

## CLEARANCES / HEIGHT REQUIREMENTS

5. **Mantel clearances:** The canopy supplied with the unit must be installed. If a combustible mantel is installed. It must meet the clearance requirements detailed in *Figure 10*.



*Figure 10. Minimum Mantel Clearances*

## FIREPLACE FRAMING

If unit is to be "built in", fireplace framing can be built before or after the appliance is set in place. **BE SURE THAT ALL PACKING MATERIAL HAS BEEN REMOVED FROM THE UNDERSIDE OF THE UNIT PRIOR TO SETTING THE FIREBOX IN PLACE.** Construct fireplace framing following *Figures 11 through 14*. Refer to *Figure 2 on page 6* for fireplace dimensions. The framing headers may rest directly on top of the firebox.

The fireplace may be installed directly on a combustible floor or a raised platform of an appropriate height. Do not place fireplace on carpeting, vinyl, tile or other soft floor coverings. It may, however, be placed on flat wood, plywood, particle board or other hard surfaces. Be sure fireplace rests on a solid continuous floor or platform with appropriate framing for support and so that no cold air can enter from under the firebox.

Anchor fireplace to the side framing members using optional nailing flange kit. Refer to installation instructions included with the kit.

	DFC/GFC32	DFC/GFC36	DFC/GFC42
A	37 1/4	41 1/4	47 1/4
B	38 1/2	38 1/2	38 1/2
C	28 3/4	32 1/2	38 3/4
D	14 1/2	16 1/4	19 1/2
E	60 3/4	65 1/4	70 3/4
F	30 1/2	35 1/2	35 1/2
G	16	16	16
H	8	8	8
J	37 3/4	40 3/4	45

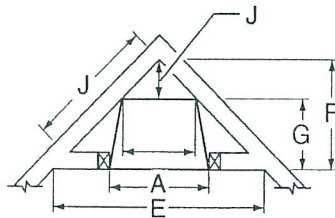


Figure 11

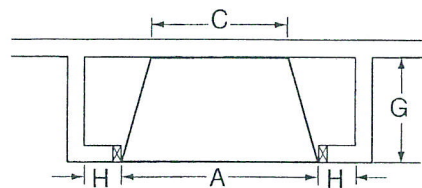


Figure 12

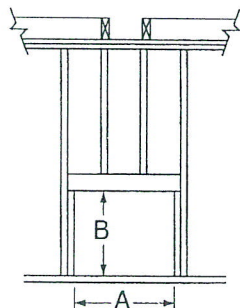


Figure 13

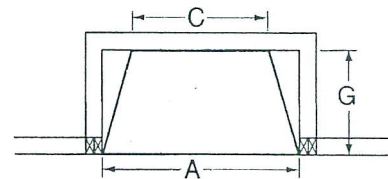


Figure 14

### WARNING

The fireplace must be installed giving full consideration to the clearance and height requirements identified in this manual.

- Step 1.** Bend out the nailing flanges located on each side of the firebox (two on each side).
- Step 2.** Slide the firebox into prepared framing or position firebox in its final position and frame later.
- Step 3.** Level the firebox by checking the top edge of the firebox. Shim if necessary.
- Step 4.** Anchor firebox to the side framing members using 8d nails or other suitable fasteners. Refer to Figure 15 below.
- Step 5.** The canopy must be installed for safe operation of the heater. Refer to page 9 for canopy installation details.



FIGURE 15

## CONNECTING THE GAS

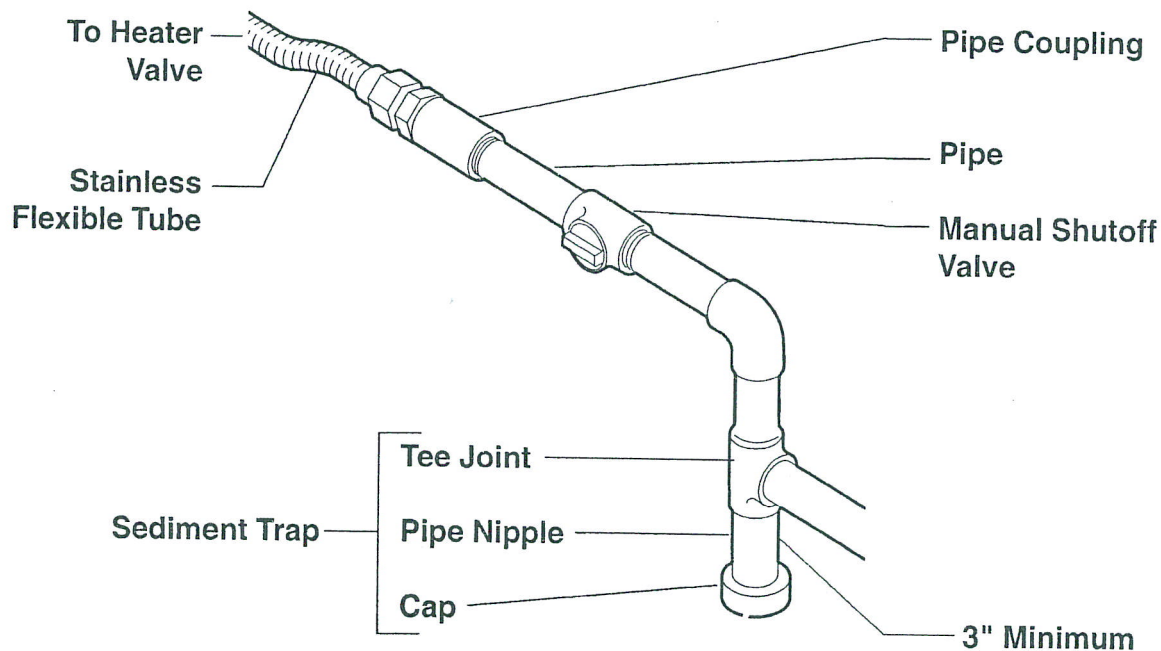
**NOTICE:** A qualified gas appliance installer must connect the heater to the gas supply. Consult all local codes.

### CAUTION

Use new black iron pipe, steel pipe, copper tubing or internally tinned copper tubing. Internally tinned copper tubing can only be used per National Fuel Code, section 2.6.3, providing gas meets sulfide limits, and where permitted by local codes. Gas piping system must be sized to provide minimum inlet pressure (listed on Data Plate) at the maximum flow rate (BTU/Hr). Undue pressure loss will occur if the pipe is too small.

A manual shutoff valve must be installed upstream of the appliance. Union tee and plugged 1/8" NPT pressure tapping point should be installed upstream of the appliance. Refer to *Figure 16*.

A sediment trap should be installed upstream to prevent moisture and contaminants from passing through the pipe to appliance controls and burners. Failure to do so could prevent the appliance from operating reliably. Refer to *Figure 16*.



*Figure 16: Gas Connection*

**IMPORTANT:** Loosen the pipe adapter on the flex tube before installing to the system piping.

**Check gas type:** The gas supply must be the same as stated on the heater's rating plate. If the gas supply is different, **DO NOT INSTALL THE HEATER.** Contact your dealer for the correct model.

**Always use an external regulator for all propane/L.P.G. heaters only,** to reduce the supply tank pressure to a maximum of 13" w.c. This is in addition to the internal regulator in the heater valve.

## CHECKING GAS PRESSURE

### WARNING

Connecting directly to an unregulated propane/L.P.G. tank can cause an explosion.

Test all gas joints from the gas meter to the heater valve for leaks using a gas analyzer or soap and water solution after completing connection. **DO NOT USE AN OPEN FLAME.**

Check the gas pressure with the appliance burning and the control set to **HIGH**.

Open control access door at bottom front of unit to find valve and regulator referred to below.

### Manual Control (Figure 17)

The pressure regulator is preset and locked to discourage tampering. If the pressure is not as specified, replace the regulator with the correct part from the parts list in this manual.

Remove 1/8" NPT plug, located on side of regulator body. Install fitting and tubing to pressure gauge. After taking pressure reading, re-install test plug. Check for gas leaks.

### Millivolt Control (Figure 17a)

The valve regulator controls the burner pressure which should be checked at the pressure test point. Turn captured screw counter clockwise 2 or 3 turns and then place tubing to pressure gauge over test point (Use test point "A" closest to control knob). After taking pressure reading, be sure and turn captured screw clockwise firmly to re-seal. Do not over torque. Check for gas leaks.

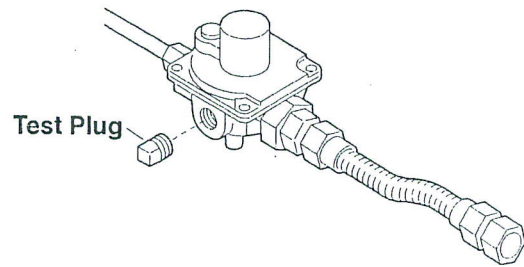


Figure 17: Pressure Test Point Location

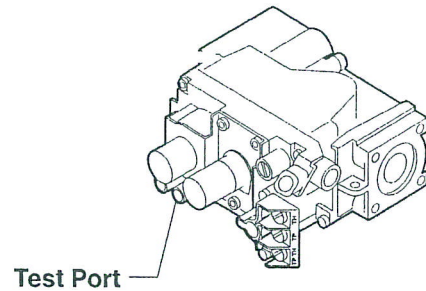
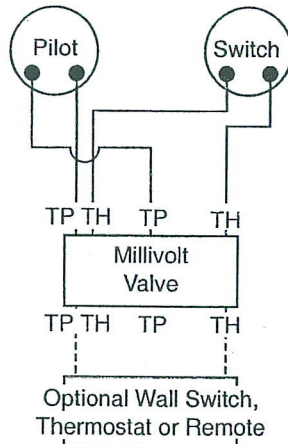


Figure 17a: Pressure Test Point Location

## ELECTRICAL WIRING (Millivolt)

**CAUTION**  
Label all wires prior to disconnection when servicing controls. Wiring errors can cause improper and dangerous operation. Verify proper operation after servicing.



*Figure 18: Schematic and Wiring Diagram*

The Milli-Volt (thermopile) is a self powered combination gas control, does not require 110vac to operate. Refer to **Figure 18** and installation instructions provided with optional wall switch, thermostat or remote control for wiring instructions. A maximum length of 20 feet of 18awg two conductor wire is to be used for wall switch or thermostat installations. Note thermostats and switches must be suitable for millivolt operation.

### Checking System Operation

The millivolt system and individual components may be checked with a millivolt meter having a 0-1000MV range. Conduct each check shown in chart below by connection meter test leads to terminals as indicated.

CHECK TEST	TO TEST	CONNECT METER LEADS TO TERMINALS	THERMOSTAT CONTACTS	METER READING SHOULD BE
A	COMPLETE SYSTEM	2 & 3	CLOSED	CLOSED
B	THERMOPILE OUTPUT	1 & 2	OPEN	OPEN

#### A. Complete Millivolt System Check ("A" Reading - Thermostat contacts CLOSED - Control Knob "ON" - Main burner should be come ON)

- If the reading is more than 100 millivolts and the automatic valve still does not come on - replace the control.
- If the closed circuit reading ("A" reading) is less than 100 millivolts, determine cause for low reading - proceed as follows:

#### B. Thermopile Output Reading Check ("B" Reading - Thermostat contacts OPEN - Main burner OFF)

- CP-2 system - 325 millivolts minimum. If the minimum millivolt reading is not obtainable, readjust pilot for maximum millivolt output. If millivolt reading is still below minimum specified, replace thermopile.

## LOG PLACEMENT

*Before you begin:* This unit is supplied with a set of four ceramic fiber logs. Do not handle these logs with your bare hands! **Always wear gloves to prevent skin irritation from ceramic fibers.** After handling logs, wash your hands gently with soap and water to remove any traces of fibers.

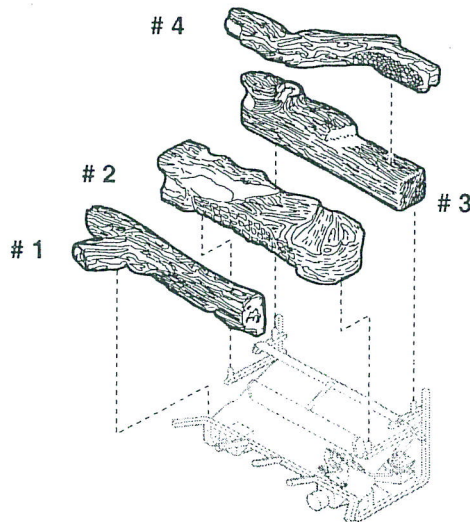
### WARNING

The positioning of the logs is critical to the safe and clean operation of this heater. Sooting and other problems may result if the logs are not properly and firmly positioned in the appliance. Never add additional logs or embellishments such as pine cones, vermiculite or rock wool to the heater.

#### *Proper installation sequence:*

1. Install the **rear log (#3)** on the top set of locating pins. Visually check to verify the log is securely placed on the pins, and in contact with the grate.
2. Install the **front log (#1)** on top of the piezo and control cover. Center the log left to right to properly engage the locator lugs.
3. Install the **center log (#2)** behind the front log on the remaining set of locating pins. Visually check to verify the log is securely placed on the pins.
4. Install the **cross log (#4)** by engaging the holes in the cross log onto pins on the center and/or rear log.

*Figure 19: Proper Sequence of Log Installation*



### WARNING

Failure to position the parts in accordance with these diagrams or failure to use only parts specifically approved with this heater may result in property damage or personal injury.

#### *Placing the decorative volcanic rock:*

### CAUTION

**DO NOT** sprinkle volcanic rock on the logs or around the pilot or the main burner. This may cause sooting. Only place volcanic rock on the floor of the fireplace.

During initial operation of the new heater, burning logs will give off a paper burning smell and orange flames will be present. Simply open the windows for a few hours to vent the odor.

## FLAME APPEARANCE

---

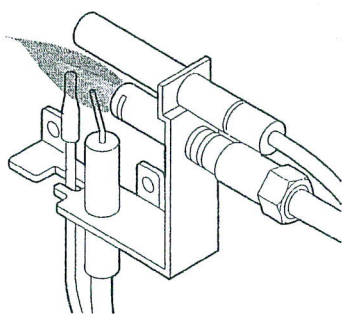
Flames from the pilot, front and rear burner should be visually checked as soon as the heater is installed. In addition, periodically check the flames visually during operation.

### *Checking the pilot flame:*

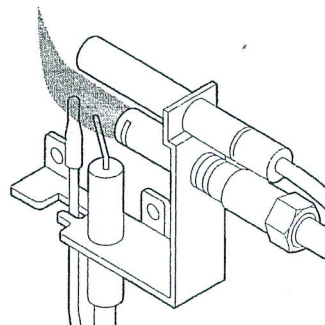
The pilot flame must always be present when the heater is in operation. It should just touch the top of the thermocouple tip. Refer to *Figure 20 and 22*.

If the pilot flame does not touch the thermocouple, then the main burner cannot function reliably. Refer to *Figure 21 and 23* for incorrect shape of pilot flame.

### Millivolt Control

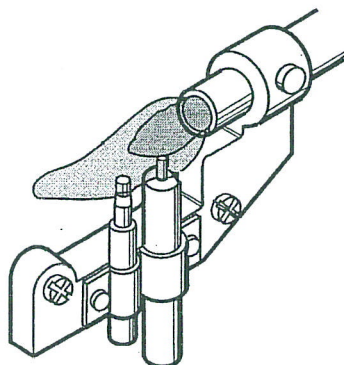


*Figure 20: Correct Appearance of Pilot Flame*

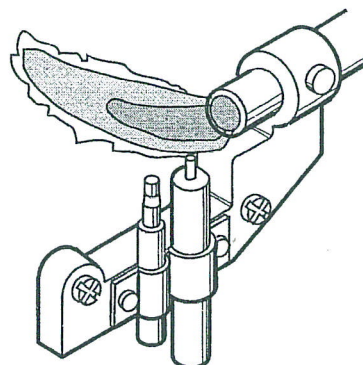


*Figure 21: Incorrect Appearance of Pilot Flame*

### Manual and Thermostat Control



*Figure 22: Correct Appearance of Pilot Flame*

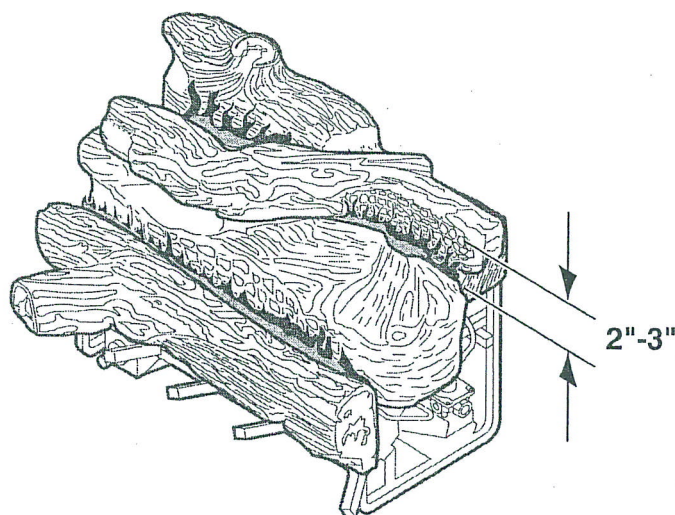


*Figure 23: Incorrect Appearance of Pilot Flame*

## CHECKING THE BURNER FLAME

In normal operation at full rate after 15 minutes, the following flame appearances should be observed:

The rear flames above and behind log #2, and in front of log #3, may be **yellow**. The flames should extend approximately 2" - 3" above log #2. Refer to *Figure 24*.



*Figure 24: Correct Appearance of Rear Flames*

The front burner flames are **blue**, becoming yellowish as they hit the bumps on the face of the front log. The face of the front log will glow a bright reddish orange when the heater is in operation.

### OPERATING INSTRUCTIONS

**Avoid any drafts that alter burner flame patterns.** Do not allow fans to blow directly into the fireplace. Do not place a blower inside the burn area of the firebox. Ceiling fans may create drafts that alter flame patterns. Sooting and improper burning will result.

During manufacturing, fabricating and shipping, various components of this appliance are treated with certain oils, films or bonding agents. These chemicals are not harmful, but may produce annoying smoke and smells as they are burned off during the initial operation of the appliance, possibly causing headaches or eye or lung irritation. *This is a normal and temporary occurrence.*

The initial break-in operation should last 2-3 hours with the burner at the highest setting. Provide maximum ventilation by opening windows or doors to allow odors to dissipate. Any odors remaining after this initial break-in will be slight and will disappear with continued use.

This appliance must not be used with glass doors in the closed position. This can lead to pilot outages and severe sooting outside the fireplace.

## OPERATING INSTRUCTIONS

### FOR YOUR SAFETY READ BEFORE LIGHTING

#### WARNING

If you do not follow these instructions exactly, a fire or explosion may result causing property damage, personal injury or loss of life.

- A. This appliance is equipped with an ignition device which automatically lights the pilot. Do not try to light the pilot by hand.
- B. BEFORE OPERATING smell all around the appliance area for gas. Be sure to smell next to the floor because some gas is heavier than air and will settle on the floor.

#### WHAT TO DO IF YOU SMELL GAS:

- Do not attempt to light any appliance.
  - Do not touch any electric switch; do not use any phone in your building.
  - Immediately call your gas supplier from a neighbor's phone. Follow the gas supplier's instructions.
  - If you cannot reach your gas supplier, call the fire department.
- C. Use only your hand to push in, or turn the gas control knob. Never use tools. If the knob will not push in or turn by hand, don't try to repair it. Call a qualified service technician. Force or attempted repair may result in a fire or explosion.
  - D. Do not use this appliance if any part of it has been under water. Immediately call a qualified service technician to inspect the appliance and to replace any part of the control system and any gas control that has been under water.



Figure 25: Location of Piezo Ignitor & Control Knob

## OPERATING INSTRUCTIONS

### MANUAL CONTROL LIGHTING INSTRUCTIONS

1. STOP! Read the safety information.
2. Make sure the manual shutoff valve is fully open.
3. This heater is equipped with an ignition device (piezo) which automatically lights the pilot.
4. Refer to *Figure 25* for the location of the piezo ignitor and control knob. Push in gas control knob slightly and turn control knob clockwise to the OFF position.  
NOTE: Knob cannot be turned to OFF unless knob is pushed in slightly. Do not force.
5. Wait 5 minutes to clear out any gas. Then smell for gas, including near the floor. If you smell gas STOP! Follow the instructions under "WHAT TO DO IF YOU SMELL GAS". If you do not smell gas, go to the next step.
6. From OFF position, push in gas control knob slightly and turn counterclockwise to the IGN position. See *Figure 26*. Push in and hold control knob for 5 seconds.  
NOTE: If you are running the heater for the first time, it will be necessary to press in the control knob for 30 seconds to allow air to bleed out of the gas piping.
7. With the control knob pushed in, push and release the piezo ignitor button to light the ODS pilot. The pilot is located on the right side of the heater, behind the front log and in front of the main burner. If piezo ignitor does not light the pilot, refer to "*Match Lighting Instructions*".
8. Hold the control knob in for an additional 10 seconds to prevent the ODS pilot from shutting off the gas while the thermocouple is warming up.
9. Release the control knob.  
\* If the knob does not pop out when released, stop and immediately call your service technician or gas supplier.  
\* If the ODS pilot will not stay lit after several tries, push and turn the gas control knob clockwise to OFF and wait 15 seconds. Repeat steps 6 through 9.
10. Push in control knob and turn to desired setting (LOW or HIGH). The control knob must be set at either the low or high position, and the control knob will pop out when positioned correctly. Do not set the control knob at a position between LOW and HIGH. Refer to *Figure 27*.

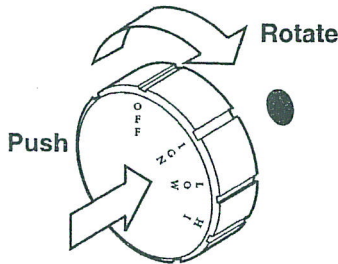


Figure 26: IGN Position

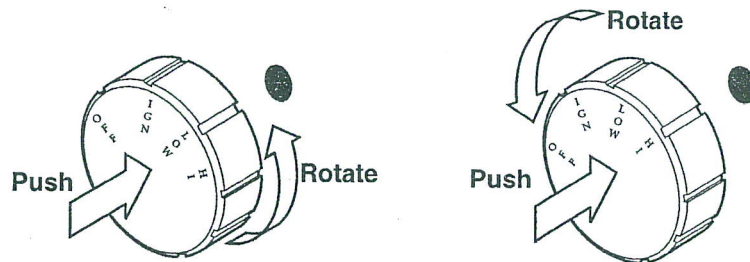


Figure 27: LOW/HIGH Position

**WARNING**




Wait 30 seconds before readjusting the heater when the control knob has been turned down to a lower setting.

### TO TURN OFF GAS TO HEATER

1. Turn control knob clockwise to OFF position to completely shut off the heater.
2. If applicable: Turn off all electric power to the heater.

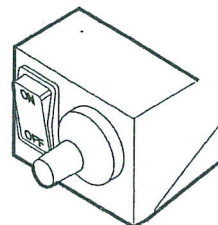
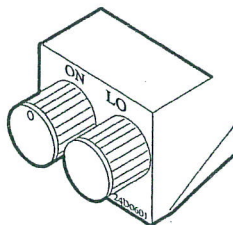
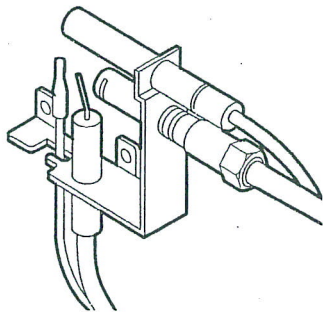
## OPERATING INSTRUCTIONS

### MILLI-VOLT CONTROL LIGHTING INSTRUCTIONS


1. STOP! Read the safety information label.
2. Make sure the manual shutoff valve is fully open.
3. This gas log set is equipped with an ignition device (piezo) which automatically lights the pilot. If piezo ignitor does not light the pilot, refer to instructions for "Match Lighting"
4. Turn gas control knob clockwise  to the "OFF" position, set the thermostat to the lowest setting and turn ON/OFF switch to OFF position.
5. Wait (5) minutes to clear out any gas. Then smell for gas, including near the floor. If you smell gas, STOP! Follow "B" in the safety information label. If you don't smell gas, go to next step.
6. From "OFF" position, turn the gas control knob counterclockwise  to "IGN" position. Push in control knob for 5 seconds.
7. With the control knob pushed in, push in and release the piezo ignitor button to light the pilot.
8. Continue pushing the control knob in for a further 60 seconds to prevent the flame detector from shutting off the gas while the probe is warming up. Release the control knob.
9. Turn gas control knob counterclockwise  to the "ON" position.
10. After the pilot has been lit for one minute, the burners can be turned on. Turn the ON/OFF switch to "ON" position or adjust thermostat to desired setting.
11. If the gas logs will not operate, follow the instructions "To Turn Off Gas To Appliance: and call your service technician or has supplier.

#### WARNING

Wait 30 seconds before readjusting the heater when the control knob has been turned down to a lower setting.



### TO TURN OFF GAS TO HEATER

1. Turn control knob clockwise  to OFF position to completely shut off the heater.
2. If applicable: Turn ON/OFF switch to OFF position and/or set thermostat (if present) to lowest setting.
3. If applicable: Turn off all electric power to the heater.

## OPERATING INSTRUCTIONS

### MATCH LIGHTING INSTRUCTIONS

1. Remove any items necessary for easy access to the pilot (for example: logs, screens, etc.).
2. Follow appropriate lighting instructions found previously. Instead of pushing and releasing the piezo button, light a match and hold the flame to the end of the pilot and ignite the pilot.
3. After control knob has been released and pilot stays lit, re-install any items that were removed for pilot access.
4. Call a qualified service technician for repair or replacement of the piezo ignitor.

### CLEANING AND SERVICING

Annual inspection and cleaning by your dealer or qualified service technician is recommended to prevent malfunction and/or sooting

**WARNING**

**Turn off heater and allow to cool before cleaning. Disconnect electrical power before cleaning or servicing.**

Remove fireplace glass frame. Refer to instruction manual for installation of glass frame. **DO NOT OPERATE THE UNIT WITH THE GLASS PANEL REMOVED.**

Remove logs, handling carefully by holding gently at each end. Gloves are recommended to prevent skin irritation from ceramic fibers. If skin becomes irritated, wash gently with soap and water. Refer to manual for correct log placement.

**Periodic Cleaning - Refer to parts diagram for location of items discussed below.**

- Do not use cleaning fluid to clean logs or any part of heater.
- Logs - brush with soft bristle brush or vacuum with brush attachment.
- Vacuum loose particles and dust from the front and rear burner, control and piezo covers and grate weldment.
- Inspect and clean rear burner air intake holes. Remove lint or particles with vacuum or brush. Failure to keep air intake holes clean will result in sooting and poor combustion.
- External case should be dusted and wiped with a wet soapy cloth.

**Annual Cleaning/Inspection - Refer to parts diagram for location of items discussed below.**

- Inspect and clean rear burner air intake holes. Remove lint or particles with vacuum or brush. Failure to keep air intake holes clean will result in sooting and poor combustion.
- Inspect and clean all burner ports.
- Inspect ODS pilot for operation and accumulation of lint at air intake holes.
- Verify flame pattern and log placement for proper operation.
- Verify smooth and responsive ignition of main burner and rear burner.

## CLEANING AND SERVICING

### Cleaning Glass Frame

It will be necessary to clean the glass periodically. During initial start up, condensation will form inside the glass and cause lint, dust and other airborne particles to cling to the glass surface. Also initial paint curing may deposit a slight film on the glass. It is therefore recommended that the glass to be cleaned two or three times with a non ammonia household cleaner and warm water (*we recommend "Windex Cleaner"*). Use a non abrasive cloth to avoid scratching glass. After that the glass should be cleaned two or three times during each heating season depending on the circumstances present.

**WARNING**

Electrical connections should only be performed by a qualified, licensed electrician, main power must be off when connecting to main electrical power supply or performing service.

### Cleaning Catalytic Filter

The catalytic filters require cleaning at least once a year to work effectively. From the inside the combustion area, use a brush with soft bristles or vacuum with brush attachment to clean the outer surface of the catalytic filter. After cleaning, install the catalytic filter back to the unit. Replacement of the catalytic component should be completed by a qualified service person at least every five to ten years.

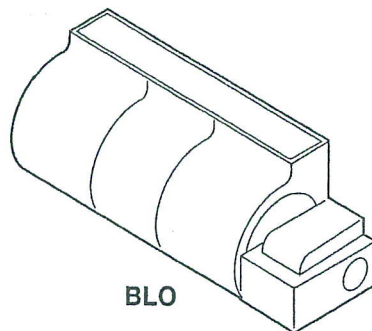
**WARNING**

Never use the unit without a catalytic filter. **DO NOT OPERATE THE UNIT WITH THE CATALYTIC FILTER REMOVED.**

### OPTIONAL EQUIPMENT

#### Forced Air Kit (*Circulating Models only*)

If you are installing the forced air kit, Model BLO see the installation instructions provided with the kit for electrical wiring requirements, or the blower installation section. The firebox must be connected to main power supply at time of firebox installation. The blower must be installed prior to the installation of the unvented heater. The electrical connections must be made before the firebox is framed and enclosed in the finished walls.



#### Brass Louvers (*Circulating Models only*)

Optional brass louvers may be installed in place of the factory installed black louvers. Refer to installation instructions provided with the brass or chrome louvers.

#### Brass or Chrome Trim

Optional brass trim kit can be used with unit when installed as a free standing fireplace with wood surround.

#### Firebricks

Optional firebrick kits can be installed. Refer to installation instructions provided with kit.

**CAUTION**

Electrical connections should only be performed by a qualified, licensed electrician, main power must be off when connecting to main electrical power supply or performing service.

# PARTS LIST / ILLUSTRATION

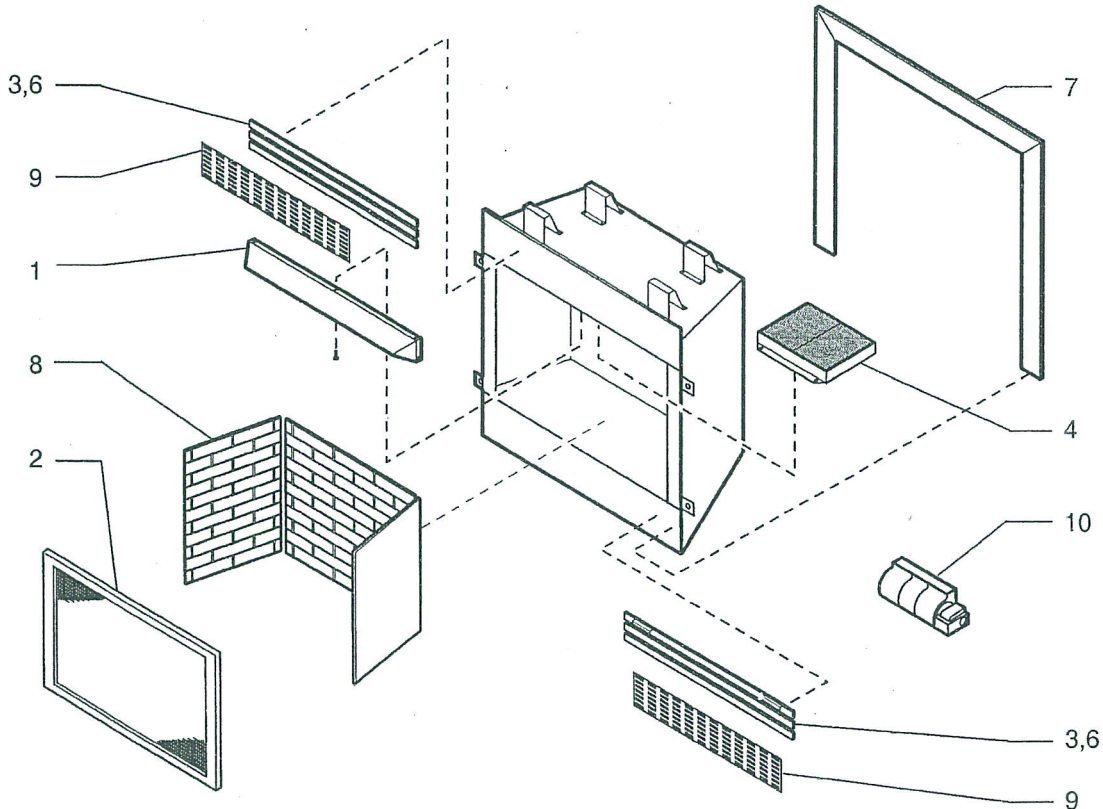
## STANDARD FEATURES

ITEM	DESCRIPTION	QTY	DFCC/GFCC32	DFCC/GFCC36	DFCC/GFCC42
1	Canopy	1	26D0713	26D0715	26D0717
2	Glass Frame Assembly	1	26D2544	26D2545	26D2546
3	Black Louver	6	26D0695	26D0697	26D0699
4	Catalytic Filter	3	26D2528	26D2528	26D2528

## ACCESSORIES

ITEM	DESCRIPTION	QTY	DFCC/GFCC32	DFCC/GFCC36	DFCC/GFCC42
6	Brass Louver	1	L32BR	L36BR	L42BR
6	Chrome Louver	1	L32CH	L36CH	L42CH
7	Brass Trim Flat Design	1	BRTK32A	BRTK36A	BRTK42A
7	Brass Trim S Design	1	BRTK32B	BRTK36B	BRTK42B
7	Brass Trim Curved Design	1	BRTK32C	BRTK36C	BRTK42C
7	Chrome Trim Flat Design	1	CHTK32A	CHTK36A	CHTK42A
7	Chrome Trim S Design	1	CHTK32B	CHTK36B	CHTK42B
7	Chrome Trim Curved Design	1	CHTK32C	CHTK36C	CHTK42C
8	Firebrick Traditional	1	FB32T1	FB36T1	FB42T1
8	Firebrick Aged Brick	1	FB32A1	FB36A1	FB42A1
8	Firebrick Weathered	1	FB32W1	FB36W1	FB42W1
9	Brass Fillgree Kit	1	BRFK32	BRFK36	BRFK42
10	Blower w/Rheostat	1	BLO	BLO	BLO
11	*Door Chrome	1	D32CH	D36CH	D42CH
12	*Black Arched Screen	1	BLAR32	BLAR36	BLAR42

\* NOT ILLUSTRATED



# REPLACEMENT PARTS LIST

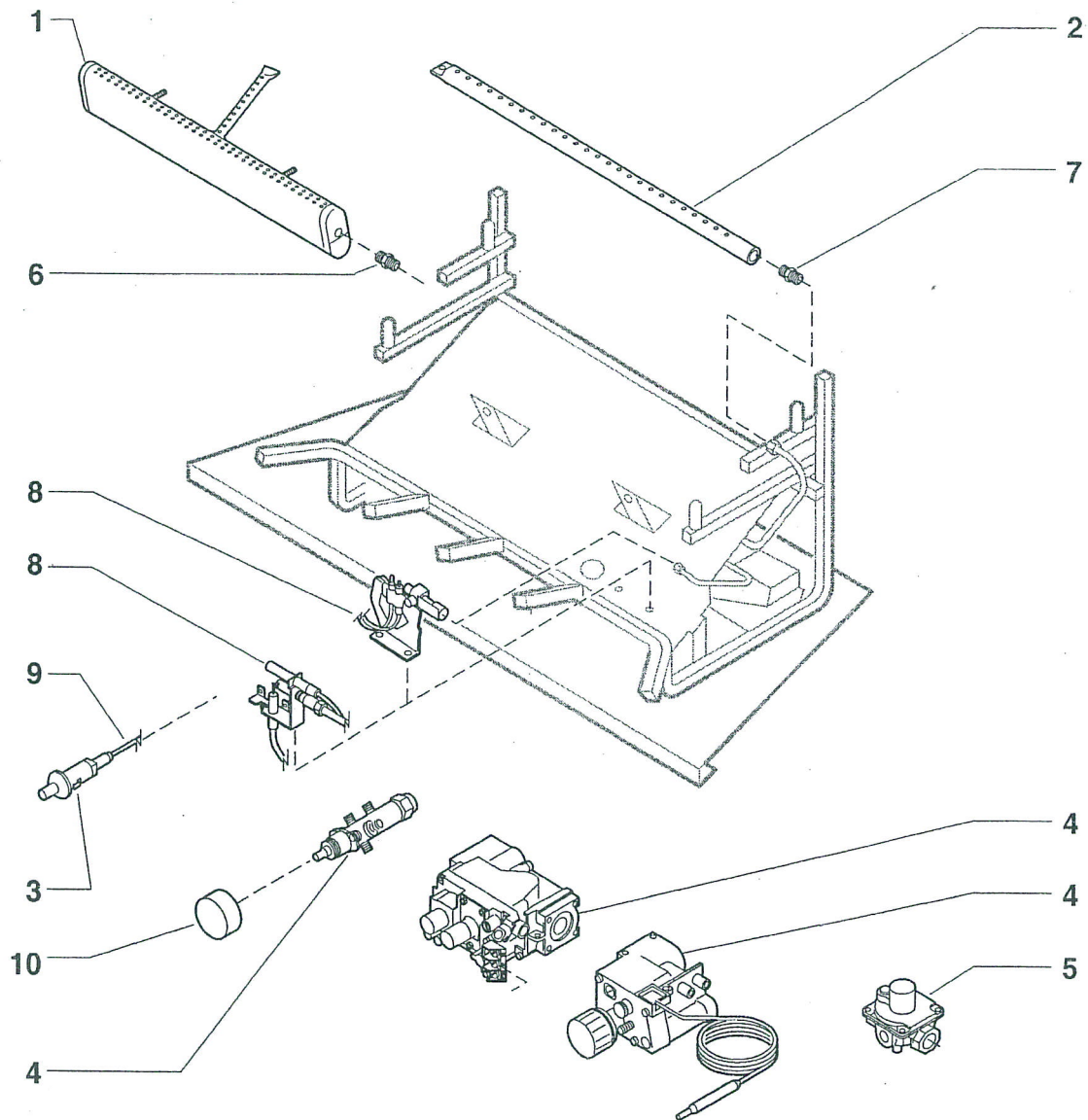
REPLACEMENT PARTS ARE AVAILABLE THROUGH YOUR RETAILER.

Item	Description	Qty	DFC/GFC 32		DFC/GFC 36		DFC/GFC 42	
			Natural	Propane	Natural	Propane	Natural	Propane
<b>Common Parts</b>								
1	Burner Front	1	14D0433	14D0433	14D0434	14D0434	14D0434	14D0434
2	Burner Rear	1	14D2255	14D2285	14D2257	14D2286	14D2257	14D2286
3	Ignitor Piezo	1	00F0011 00F0587	00F0011 00F0587	00F0011 00F0587	00F0011 00F0587	00F0011 00F0587	00F0011 00F0587
<b>Manual Control</b>								
4	Valve Control	1	00K0910	00K0910	00K0910	00K0910	00K0910	00K0910
5	Valve Regulator	1	18D0351	18D0352	18D0351	18D0352	18D0351	18D0352
6	Injector Main	1	24D0549	18D0515	25D0525	00K0915	25D0525	00K0915
7	Injector Rear	1	15D0552	14D0563	14D0572	14D0571	14D0572	14D0571
8	Pilot ODS Ass'y	1	14D2259	14D2262	14D2259	14D2262	14D2259	14D2262
9	Wire Piezo	1	00K0632	00K0632	00K0632	00K0632	00K0632	00K0632
10	Control Knob	1	18D0601	18D0601	18D0601	18D0601	18D0601	18D0601
<b>Millivolt Control</b>								
4	Valve Control	1	14D0467	14D0468	14D0467	14D0468	14D0467	14D0468
5	Valve Regulator		N/A	N/A	N/A	N/A	N/A	N/A
6	Injector Main	1	24D0549	18D0515	25D0525	00K0915	25D0525	00K0915
7	Injector Rear	1	15D0552	14D0563	14D0572	14D0571	14D0572	14D0571
8	Pilot ODS Ass'y	1	14D2263	14D2264	14D2263	14D2264	14D2263	14D2264
9	Wire Piezo	1	00K0632	00K0632	00K0632	00K0632	00K0632	00K0632
10	Control Knob	2	18D0603	18D0603	18D0603	18D0603	18D0603	18D0603

<b>Accessories</b>		
Connector, Flex	FLEXCON24	AllModels
Switch, Wall Kit	MVWS	Millivolt only
Thermostat, Wall Kit	MVWTS	Millivolt only
Remote, Hand Held	MVHHR	Millivolt only
Remote, Hand Held Thermostat	MVHHR-T	Millivolt only

**WARNING**

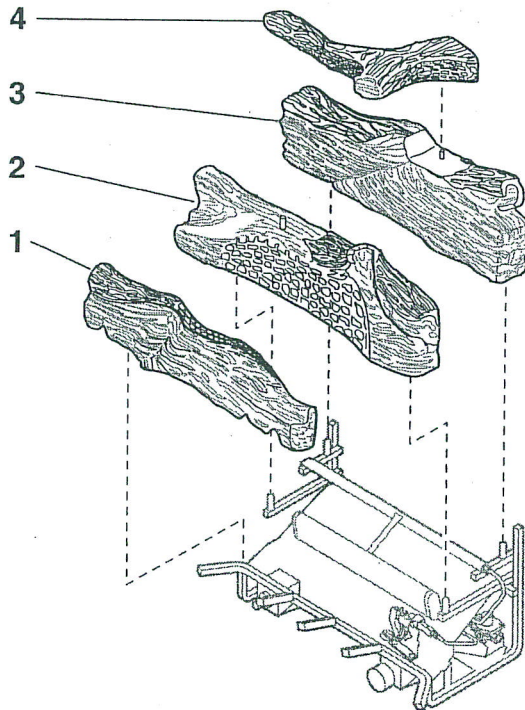
Failure to position the parts in accordance with these diagrams or failure to use only parts specifically approved with this appliance may result in property damage or personal injury.



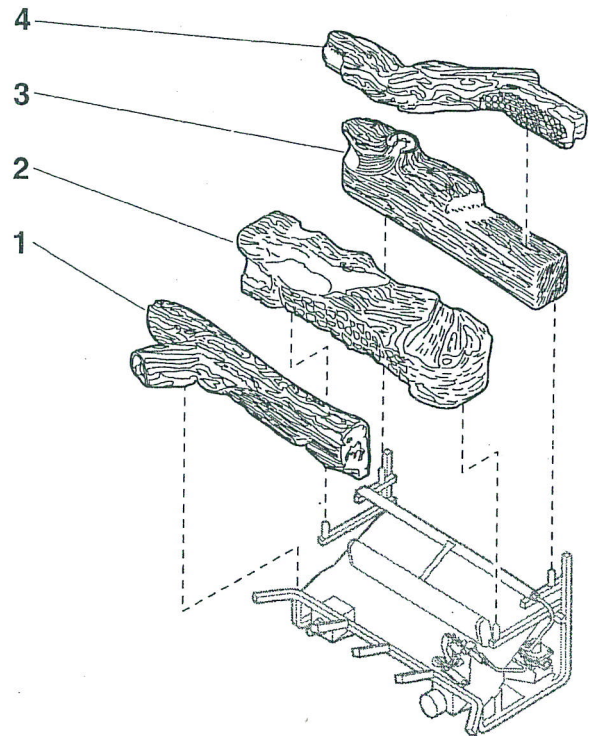
# REPLACEMENT PARTS LIST

REPLACEMENT PARTS ARE AVAILABLE THROUGH YOUR RETAILER.

Item	Description	Qty	DFC 32	DFC 36	DFC 42
<b>DFS Aged Split Logs</b>					
1	Log Front	1	14D2019	14D2031	14D2041
2	Log Center	1	14D2020	14D2032	14D2042
3	Log Rear	1	14D2021	14D2033	14D2043
4	Log Top	1	14D2093	14D2022	14D2022
<b>GFS Weathered Split Logs</b>			<b>GFC 32</b>	<b>GFC 36</b>	<b>GFC 42</b>
1	Log Front	1	26D0628	26D0632	26D0636
2	Log Center	1	26D0629	26D0633	26D0637
3	Log Rear	1	26D0630	26D0634	26D0638
4	Log Top	1	26D0631	26D0635	26D0635



GFC Weathered Split Logs



DFC Aged Split Logs



## TROUBLESHOOTING

**WARNING**

Turn appliance OFF and allow to cool before servicing. Only a qualified service person should service and repair the heater.

*Note: All troubleshooting items are listed in order of operation.*

OBSERVED PROBLEM	POSSIBLE CAUSE	REMEDY
When ignitor button is pressed, there is no spark at ODS/pilot.	<ol style="list-style-type: none"> <li>1. Ignitor electrode positioned wrong.</li> <li>2. Ignitor electrode is broken.</li> <li>3. Ignitor electrode not connected to ignitor cable.</li> <li>4. Ignitor cable pinched or wet. Keep ignitor cable dry.</li> <li>5. Broken ignitor cable.</li> <li>6. Bad piezo ignitor.</li> </ol>	<ol style="list-style-type: none"> <li>1. Replace ignitor.</li> <li>2. Replace ignitor.</li> <li>3. Reconnect ignitor cable.</li> <li>4. Free ignitor cable if pinched by any metal or tubing.</li> <li>5. Replace ignitor cable.</li> <li>6. Replace piezo ignitor.</li> </ol>
Appliance produces unwanted odors.	<ol style="list-style-type: none"> <li>1. Appliance burning vapors from paint, hair spray, glues, etc.</li> <li>2. Gas leak.</li> </ol>	<ol style="list-style-type: none"> <li>1. Ventilate room. Stop using odor causing products while heater is running.</li> <li>2. Locate and correct all leaks.</li> </ol>
Appliance shuts off during use.	<ol style="list-style-type: none"> <li>1. Not enough fresh air is available for ODS/pilot to operate.</li> <li>2. Low line pressure.</li> <li>3. ODS/pilot is partially clogged.</li> <li>4. Defective Thermopile</li> </ol>	<ol style="list-style-type: none"> <li>1. Open window and/or door for ventilation.</li> <li>2. Contact local gas company.</li> <li>3. Clean ODS/pilot.</li> <li>4. Check pilot flame, check wire connections, check output, should be 325 millivolts across TH/TP and TP Terminals with ON/OFF switches off.</li> </ol>
Gas odor even when control knob is in OFF position.	<ol style="list-style-type: none"> <li>1. Gas leak.</li> <li>2. Control valve defective.</li> </ol>	<ol style="list-style-type: none"> <li>1. Locate and correct all leaks.</li> <li>2. Replace control valve.</li> </ol>
When ignitor button is pressed, there is spark at ODS pilot, but no ignition.	<ol style="list-style-type: none"> <li>1. Gas supply turned off or manual shutoff valve closed.</li> <li>2. Control knob not in PILOT position.</li> <li>3. Control knob not pressed in while in PILOT position.</li> <li>4. Air in gas lines when installed.</li> <li>5. ODS/pilot is clogged.</li> <li>6. Gas regulator setting is not correct.</li> </ol>	<ol style="list-style-type: none"> <li>1. Turn on gas supply or open manual shutoff valve.</li> <li>2. Turn control knob to PILOT position.</li> <li>3. Press in control knob while in PILOT position.</li> <li>4. Continue holding down control knob. Repeat igniting operation until air is removed.</li> <li>5. Replace ODS/pilot assembly or get it serviced.</li> <li>6. Replace gas regulator</li> </ol>
ODS/pilot lights, but flame goes out when control knob is released.	<ol style="list-style-type: none"> <li>1. Control knob not fully pressed in.</li> <li>2. Control knob not pressed in long enough.</li> <li>3. Manual shutoff valve not fully open.</li> </ol>	<ol style="list-style-type: none"> <li>1. Press in control knob fully.</li> <li>2. After ODS/pilot lights, keep control knob pressed in for 30 seconds.</li> <li>3. Fully open manual shutoff valve.</li> </ol>

**OBSERVED PROBLEM****POSSIBLE CAUSE****REMEDY**

	<ol style="list-style-type: none"> <li>4. Thermocouple connection loose at control valve.</li> <li>5. Pilot flame not touching thermocouple, which allows thermocouple to cool, causing pilot flame to go out. This problem could be caused by either low gas pressure, or a dirty or partially clogged ODS/pilot.</li> <li>6. Thermocouple damaged.</li> <li>7. Control valve damaged.</li> </ol>	<ol style="list-style-type: none"> <li>4. Hand tighten until snug, then tighten 1/4 turn more.</li> <li>5. Contact local gas company.</li> <li>6. Replace thermocouple.</li> <li>7. Replace control valve.</li> </ol>
<b>One or both burners do not light after ODS/pilot is lit.</b>	<ol style="list-style-type: none"> <li>1. Burner orifice is clogged.</li> <li>2. Burner orifice diameter is too small.</li> <li>3. Inlet gas pressure is too low.</li> </ol>	<ol style="list-style-type: none"> <li>1. Clean burner or replace burner orifice.</li> <li>2. Replace burner orifice.</li> <li>3. Contact qualified service person.</li> </ol>
<b>Burner backfires during combustion.</b>	<ol style="list-style-type: none"> <li>1. Manifold pressure is too low.</li> <li>2. Burner orifice is clogged.</li> </ol>	<ol style="list-style-type: none"> <li>1. Contact local gas company.</li> <li>2. Clean burner or replace burner orifice.</li> </ol>
<b>Slight smoke or odor during initial operation.</b>	<ol style="list-style-type: none"> <li>1. Burner orifice is clogged or damaged.</li> <li>2. Burner is damaged.</li> <li>3. Gas regulator defective.</li> </ol>	<ol style="list-style-type: none"> <li>1. Clean burner or replace burner orifice.</li> <li>2. Replace burner.</li> <li>3. Replace gas regulator.</li> </ol>
<b>Logs appear to smoke after initial operation.</b>	<ol style="list-style-type: none"> <li>1. Vapors from paint or curing process of logs.</li> </ol>	<ol style="list-style-type: none"> <li>1. Problem will stop after a few hours of operation. Run the heater with the damper open if you have one, or open window for the first few hours.</li> <li>1. Log heater is intended to be smokeless. Turn OFF heater and call qualified service person.</li> </ol>
<b>Heater produces a whistling noise when burner is lit.</b>	<ol style="list-style-type: none"> <li>1. Turning control knob to HIGH position when burner is cold.</li> <li>2. Air in gas line.</li> <li>3. Dirty or partially clogged burners orifice.</li> </ol>	<ol style="list-style-type: none"> <li>1. Turn control knob to LOW position and let warm up for a minute.</li> <li>2. Operate burner until air is removed from line. Have gas line checked by local gas company.</li> <li>3. Clean burner or replace burner orifice.</li> </ol>
<b>No gas to pilot.</b>	<ol style="list-style-type: none"> <li>1. LP-regulator shut down due to inlet pressure too high.</li> </ol>	<ol style="list-style-type: none"> <li>1. Verify LP tank regulator is installed and set at 11" to 13" w.c.</li> <li>2. Replace regulator on heater.</li> </ol>

**WARNING**

If the gas quality is bad, your pilot may not stay lit, the burners may produce soot and the heater may backfire when lit. If the gas quality or pressure is low, contact your local gas supplier immediately.

# MONESSEN HEARTH SYSTEMS

## LIMITED LIFETIME WARRANTY POLICY

### Lifetime Warranty

The following components are warranted for life to the original owner, subject to proof of purchase: Firebox, Combustion Chamber, Heat Exchanger, Grate and Stainless Steel Burners.

### Five Year Warranty

The following components are warranted for 5 years to the original owner, subject of proof of purchase: Ceramic Fiber Logs, Catalytic Filter and Aluminized Burners.

### Basic Warranty

Monessen Hearth Systems (MHS) warrants the components and materials in your gas appliance to be free from manufacturing and material defects for a period of one year from date of installation. After installation, if any of the components manufactured by MHS in the appliance are found to be defective in materials or workmanship, MHS will, at its option, replace or repair the defective components at no charge to the original owner. MHS will also pay for reasonable labor costs incurred in replacing or repairing such components for a period of one year from the date of installation. Any products presented for warranty repair must be accompanied by a dated proof of purchase and date of purchase.

This Limited Warranty will be void if the appliance is not installed by a qualified installer in accordance with the installation instructions. The Limited Warranty will also be void if the appliance is not operated and maintained according to the operating instructions supplied with the appliance, nor does it extend to (1) firebox damage by accident, neglect, misuse, abuse, alteration, negligence of others, including the installation thereof by unqualified installers, (2) the costs of removal, reinstallation or transportation of defective parts on the heater, or (3) incidental or consequential damage. Any service work must be performed by an authorized service representative.

This warranty is expressly in lieu of other warranties, express or implied, including the warranty of merchantability of fitness for purpose and of all other obligations or liabilities, Monessen Hearth Systems, Inc., does not assume for it, any other obligations or liability in connection with the sale or use of this heater. In states that do not allow limitations on how long an implied warranty lasts, or do not allow exclusion of indirect damages, those limitations of exclusions may not apply to you. You may also have additional rights not covered in this Limited Warranty.

MHS reserves the right to investigate any and all claims against the Limited Warranty and decide upon method of settlement.

For information about this warranty, contact:

**Technical Services  
Monessen Hearth Systems  
P.O. Box 1018  
Georgetown, Kentucky 40324**