



HBDV SERIES DIRECT VENT GAS FIREPLACE INSTALLATION AND OPERATING INSTRUCTIONS

**MODELS:
HBDV300 & HBDV400**

WARNINGS

IF THE INFORMATION IN THESE INSTRUCTIONS ARE NOT FOLLOWED EXACTLY, A FIRE OR EXPLOSION MAY RESULT CAUSING PROPERTY DAMAGE, PERSONAL INJURY OR LOSS OF LIFE.

- Do not store or use gasoline or other flammable vapors and liquids in the vicinity of this or any other appliance.
- **WHAT TO DO IF YOU SMELL GAS**
 - Do not try to light any appliance.
 - Do not touch any electrical switch; do not use any phone in your building.
 - Immediately call your gas supplier from a neighbor's phone. Follow the gas supplier's instructions.
 - If you cannot reach your gas supplier, call the fire department.
- Installation and service must be performed by a qualified installer, service agency or the gas supplier.

WARNING: Improper installation, adjustment, alteration, services or maintenance can cause injury or property damage. Refer to this manual. For assistance or additional information consult a qualified installer, service agency or the gas supplier.

This appliance may be installed in an aftermarket*, permanently located, manufactured home (USA only) or mobile home, where not prohibited by local codes.

This appliance is only for use with the type of gas indicated on the rating plate. This appliance is not convertible for use with other gases, unless a certified kit is used.

* Aftermarket: Completion of sale, not for purpose of resale, from the manufacturer.

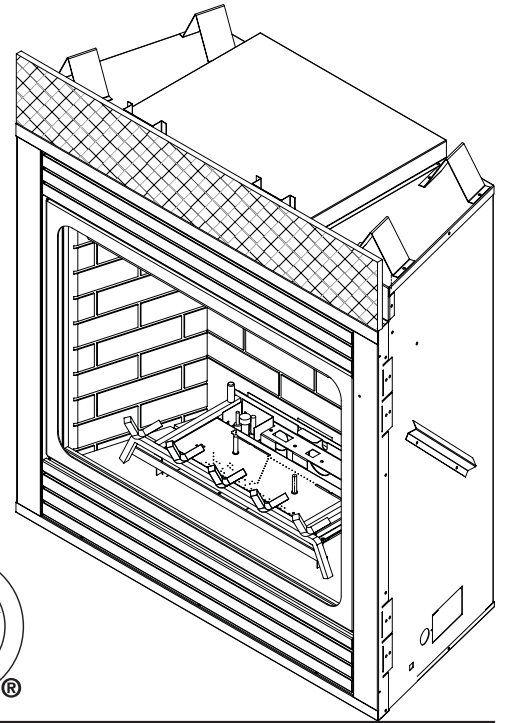

DUE TO HIGH TEMPERATURES, THE APPLIANCE SHOULD BE LOCATED OUT OF TRAFFIC AND AWAY FROM FURNITURE AND DRAPERIES.

CHILDREN AND ADULTS SHOULD BE ALERTED TO THE HAZARDS OF HIGH SURFACE TEMPERATURE AND SHOULD STAY AWAY TO AVOID BURNS OR CLOTHING IGNITION.

YOUNG CHILDREN SHOULD BE SUPERVISED WHEN THEY ARE IN THE SAME ROOM AS THE APPLIANCE.

CLOTHING OR OTHER FLAMMABLE MATERIAL SHOULD NOT BE PLACED ON OR NEAR THE APPLIANCE.

KEEP THE ROOM AREA CLEAR AND FREE FROM COMBUSTIBLE MATERIALS, GASOLINE, AND OTHER FLAMMABLE VAPORS AND LIQUIDS.

READ BEFORE INSTALLING. SAVE THESE INSTRUCTIONS

CONTENTS

Important Safety Information	3	Glass Removal & Brick Installation	32
Product Features	5	Final Installation	33–35
Code Approval	5	Placement of lava rock, rock wool and logs.....	33–35
Pre-Installation Information.....	6–9	Installing Andirons	35
High Elevation Installation.....	6	Operating Instructions (Millivolt)	36
Orifice Sizes, Pressures and BTUs.....	6	What To Do If You Smell Gas.....	36
Before You Start.....	6	Lighting Millivolt Pilot for the First Time.....	37
Fireplace Framing	7	Lighting Pilot.....	37
Fireplace Dimensions.....	8	Lighting Burner.....	38
Fireplace Location.....	9	To Turn Off Gas.....	38
Clearances	10	Cleaning and Maintenance	39
Securing Fireplace to Floor or Framing	11	Burner, Pilot and Control Compartment	39
Installation Information.....	12	Pilot Flame	39
Installation Precautions.....	12	Burner	39
Vent Installation	13	Burner Flame	39
Optional Top Vent Application	14	Vent System.....	40
Installation Planning.....	15	Glass Door	40
Rear (Through the Wall) Applications	18	Logs	40
Horizontal Termination Configuration	20	Rock Wool	40
Below Grade Installations	22	Troubleshooting	41
Vertical Through-the-Roof Installation.....	23	Replacement Parts	43–48
Installation for Vertical Termination	24	Fireplace Components.....	43–44
Vertical or Horizontal Flex Venting	26	Millivolt Engine Components	45–46
Fireplace Installation.....	28	Vent Components.....	47
Check Gas Type.....	28	Logs	48
Installing Gas Piping to Fireplace/Burner System Location.....	28	Massachusetts Residents Requirements.....	49
Checking Gas Pressure	30	Warranty	Back Cover
Electrical Installation.....	30		
Electrical Wiring	30		
Remote Wall Mounted Switch	31		
Remote Wall Switch	31		
Optional DC Remote Systems	31		
Optional Fan.....	31		

IMPORTANT SAFETY INFORMATION

INSTALLER

Please leave these instructions with the appliance.

OWNER

Please retain these instructions for future reference.

WARNING

- **Read this owner's manual carefully and completely before trying to assemble, operate, or service this fireplace.**
- **Any change to this fireplace or its controls can be dangerous.**
- **Improper installation or use of this fireplace can cause serious injury or death from fire, burns, explosions, electrical shock and carbon monoxide poisoning.**

This fireplace is a vented product. This fireplace must be properly installed by a qualified service person. The glass door must be properly seated and sealed. If this unit is not properly installed by a qualified service person with glass door properly seated and sealed, combustion leakage can occur.

CARBON MONOXIDE POISONING: Early signs of carbon monoxide poisoning are similar to the flu with headaches, dizziness and/or nausea. If you have these signs, the fireplace may not have been installed properly. Get fresh air at once! Have the fireplace inspected and serviced by a qualified service person. Some people are more affected by carbon monoxide than others. These include pregnant women, people with heart or lung disease or anemia, those under the influence of alcohol, and those at high altitudes.

Propane/LP gas and natural gas are both odorless. An odor-making agent is added to each of these gases. The odor helps you detect a gas leak. However, the odor added to these gases can fade. Gas may be present even though no odor exists.

Make certain you read and understand all warnings. Keep this manual for reference. It is your guide to safe and proper operation of this fireplace.

1. This appliance is only for use with the type of gas indicated on the rating plate. This appliance is not convertible for use with other gases unless a certified kit is used.
2. For propane/LP fireplace, do not place propane/LP supply tank(s) inside any structure. Locate propane/LP supply tank(s) outdoors. To prevent performance problems, do not use propane/LP fuel tank of less than 100 lbs. capacity.
3. If you smell gas
 - shut off gas supply.
 - do not try to light any appliance.
 - do not touch any electrical switch; do not use any phone in your building .
 - immediately call your gas supplier from a neighbor's phone. Follow the gas supplier's instructions.
4. Never install the fireplace
 - in a recreational vehicle
 - where curtains, furniture, clothing, or other flammable objects are less than 42" from the front, top, or sides of the fireplace
 - in high traffic areas
 - in windy or drafty areas
5. This fireplace reaches high temperatures. Keep children and adults away from hot surfaces to avoid burns or clothing ignition. Fireplace will remain hot for a time after shutdown. Allow surfaces to cool before touching.
6. Carefully supervise young children when they are in the room with fireplace.
7. Do not modify fireplace under any circumstances. Any parts removed for servicing must be replaced prior to operating fireplace.
8. Turn fireplace off and let cool before servicing, installing, or repairing. Only a qualified service person should install, service, or repair the fireplace. Have burner system inspected annually by a qualified service person.
9. You must keep control compartments, burners, and circulating air passages clean. More frequent cleaning may be needed due to excessive lint and dust. Turn off the gas valve and pilot light before cleaning fireplace.
10. Have venting system inspected annually by a qualified service person. If needed, have venting system cleaned or repaired. See *Cleaning and Maintenance*, page 39.
11. Keep the area around your fireplace clear of combustible materials, gasoline, and other flammable vapor and liquids. Do not run fireplace where these are used or stored. Do not place items such as clothing or decorations on or around fireplace.

Continued on page 4

IMPORTANT SAFETY INFORMATION

Continued from page 3

12. Do not use this fireplace to cook food or burn paper or other objects.
13. Never place anything on top of fireplace.
14. Do not use any solid fuels (wood, coal, paper, cardboard, etc.) in this fireplace. Use only the gas type indicated on rating plate.
15. This appliance, when installed, must be electrically grounded in accordance with local codes or in the absence of local codes, with the *National Electrical Code, ANSI/NFPA 70*, or the *Canadian Electrical Code, CSA C22.1*.
16. Do not obstruct the flow of combustion and ventilation air in any way. Provide adequate clearances around air openings into the combustion chamber along with adequate accessibility clearance for servicing and proper operation.
17. When the appliance is installed directly on carpeting, tile or other combustible material other than wood flooring, you must set appliance on a metal or wood panel or hearth pad extending the full width and depth of the appliance.
18. Do not use fireplace if any part has been exposed to or has been under water. Immediately call a qualified service person to arrange for replacement of the unit.
19. Do not operate fireplace if any log is broken.
20. Do not use a blower insert, heat exchanger insert, or any other accessory not approved for use with this fireplace.
21. Do not operate the fireplace with glass door removed, cracked, or broken.

IMPORTANT:

PLEASE READ THE FOLLOWING CAREFULLY

It is normal for fireplaces fabricated of steel to give off some expansion and/or contraction noises during the start up or cool down cycle. Similar noises are found with your furnace heat exchanger or car engine.

IMPORTANT:

PLEASE READ THE FOLLOWING CAREFULLY

It is not unusual for gas fireplaces to give off some odor the first time it is burned. This is due to the manufacturing process.

Please ensure that your room is well ventilated during burn off — open all windows.

It is recommended that you burn your fireplace for at least ten (10) hours the first time you use it. Place the fan switch in the "OFF" position during this time.

WARNING

Never connect unit to private (non-utility) gas wells. This gas is commonly known as wellhead gas.



www.nficertified.org

We suggest that our gas hearth products be installed and serviced by professionals who are certified in the U.S. by the National Fireplace Institute® (NFI) as Gas Specialists.

! WARNING



**HOT GLASS WILL CAUSE BURNS.
DO NOT TOUCH GLASS UNTIL COOLED.
NEVER ALLOW CHILDREN TO TOUCH GLASS.**

PRODUCT SPECIFICATIONS

- This appliance has been certified for use with either natural or propane gas. See appropriate data plates.
- This appliance is not for use with solid fuels.
- The appliance is approved for bedroom or bed sitting room installations.
- The appliance must be installed in accordance with local codes if any. If none exist use the current installation code. ANSI Z223.1/ NFPA 54 in the USA, CAN/CGA B149 in Canada.
- This appliance is mobile home approved.
- The appliance must be properly connected to a venting system.
- The appliance is not approved for closet or recessed installations.

The efficiency rating of this appliance is a product thermal efficiency rating determined under continuous operating conditions and was determined independently of any installed system.

Thermal efficiency up to 75%

AFUE efficiency up to 71%

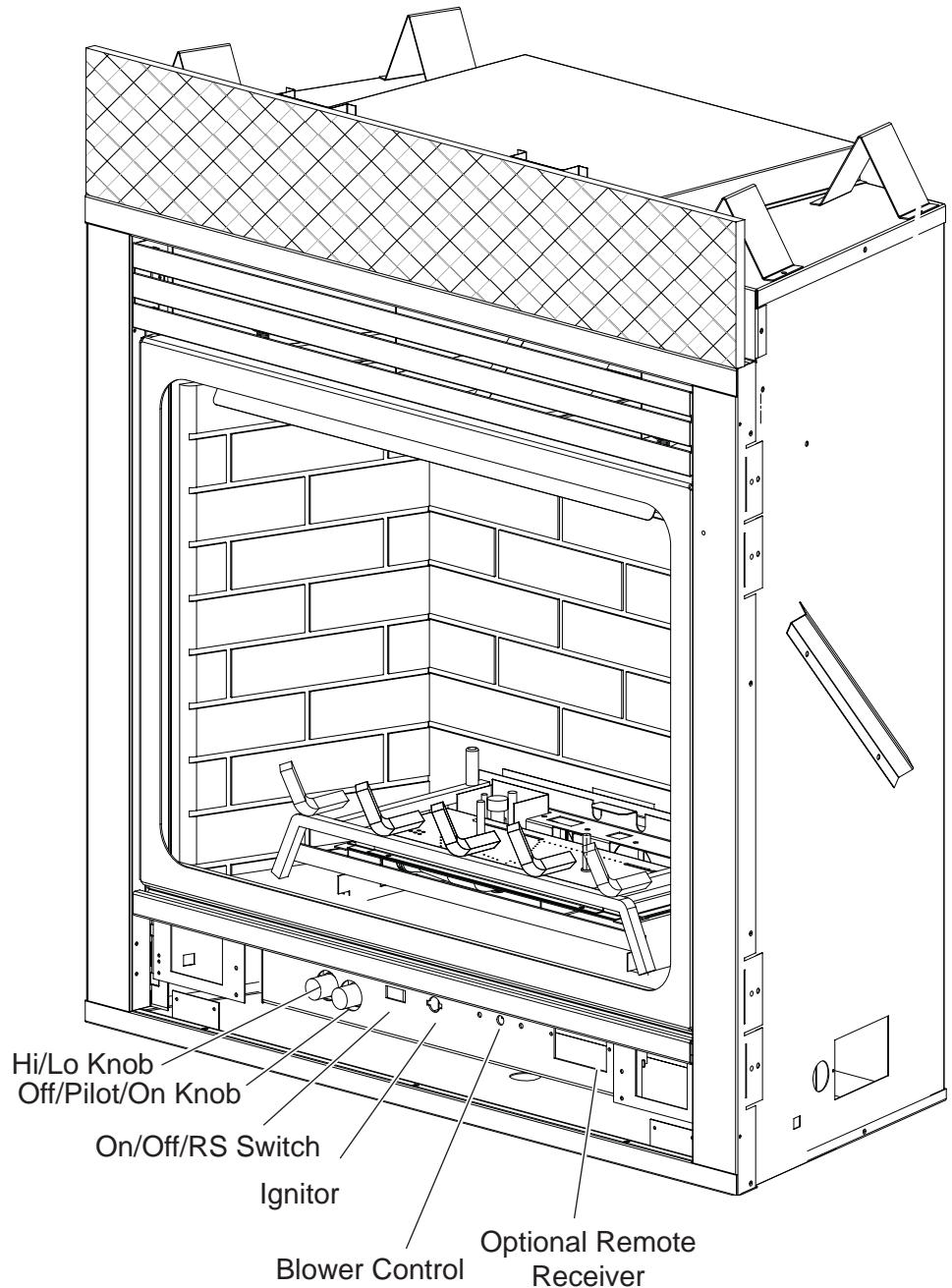

Figure 1 - HBDV300 and HBDV400 Fireplace

CODE APPROVAL

Direct Vent type appliances draw all combustion air from outside of the dwelling through the vent pipe.

These appliances have been tested by CSA and found to comply with the established standards for DIRECT VENT GAS FIREPLACE HEATERS in the USA and Canada as follows:

LISTED VENTED GAS FIREPLACE HEATER

TESTED TO: ANSI Z21.88-2007/CSA 2.33-2007 STANDARDS

A manufactured home (USA only) or mobile home OEM installation must conform with the *Manufactured Home Construction and Safety Standard, Title 24 CFR, Part 3280*, or when such a standard is not applicable, the **Standard for Manufactured Home Installations, ANSI/NCSBCS A225.1**, or **Standard for Gas Equipped Recreational Vehicles and Mobile Housing, CSA Z240.4**.

PRE-INSTALLATION INFORMATION

HIGH ELEVATIONS

Input ratings are shown in BTU per hour and are certified without deration for elevations up to 4,500 feet (1,370m) above sea level.

For elevations above 4,500 feet (1,370m) in USA, installations must be in accordance with the current ANSI Z223.1/NFPA 54 and/or local codes having jurisdiction.

In Canada, please consult provincial and/or local authorities having jurisdiction for installations at elevations above 4,500 feet (1,370m).

ORIFICE SIZES, PRESSURES AND BTUs

NATURAL GAS

Manifold Press: (W.C.) 3.5"
Maximum Supply Pressure 10.5"
Minimum Supply Pressure 4.5"

PROPANE GAS

Manifold Press: (W.C.) 10"
Maximum Supply Pressure 13"
Minimum Supply Pressure 11"

Model Number	HBDV300		HBDV400	
	Natural	Propane	Natural	Propane
Max. Btu/hr Input	23,000	23,000	27,000	26,000
Min. Btu/hr Input	16,000	18,000	19,000	20,000
Orifice size	2.35mm	1.50mm	#41	1/16

BEFORE YOU START

Read this homeowner manual thoroughly and follow all instructions carefully. Inspect all contents for shipping damage and immediately inform your dealer if any damage is found. Do not install any unit with damaged, incomplete, or substitute parts. Check your packing list to verify that all listed parts have been received. You should have the following:

- Fireplace (Firebox and Burner System)
- Rock Wool
- Log Set

ITEMS REQUIRED FOR INSTALLATION

Tools:

- Phillips Screwdriver
- Hammer
- Saw and/or saber saw
- Level
- Measuring Tape
- Electric Drill and Bits
- Pliers
- Square
- Pipe Wrench

Building Supplies:

- Framing Materials
- Wall Finishing Materials
- Caulking Material (Noncombustible)
- Fireplace Surround Material (Noncombustible)
- Piping Complying with Local Codes
- Tee Joint
- Pipe Sealant Approved for use with Propane/LPG (Resistant to Sulfur Compounds)

FIREPLACE FRAMING

Firebox framing can be built before or after the appliance is set in place. Construct firebox framing following Figure 2 and the chart below for your specific installation requirements. See Figure 3 on Page 8 for firebox dimensions. The framing headers may rest on the top of the firebox standoffs. Do not bring headers below top of standoffs.

The firebox may be installed directly on a combustible floor or raised on a platform of an appropriate height. When the firebox is installed directly on carpeting, tile, or other combustible material, other than wood flooring, the firebox shall be installed on a metal or wood panel extending the full width and depth of the enclosure.

WARNING

Do not fill spaces around firebox with insulation or other materials. This could cause a fire.

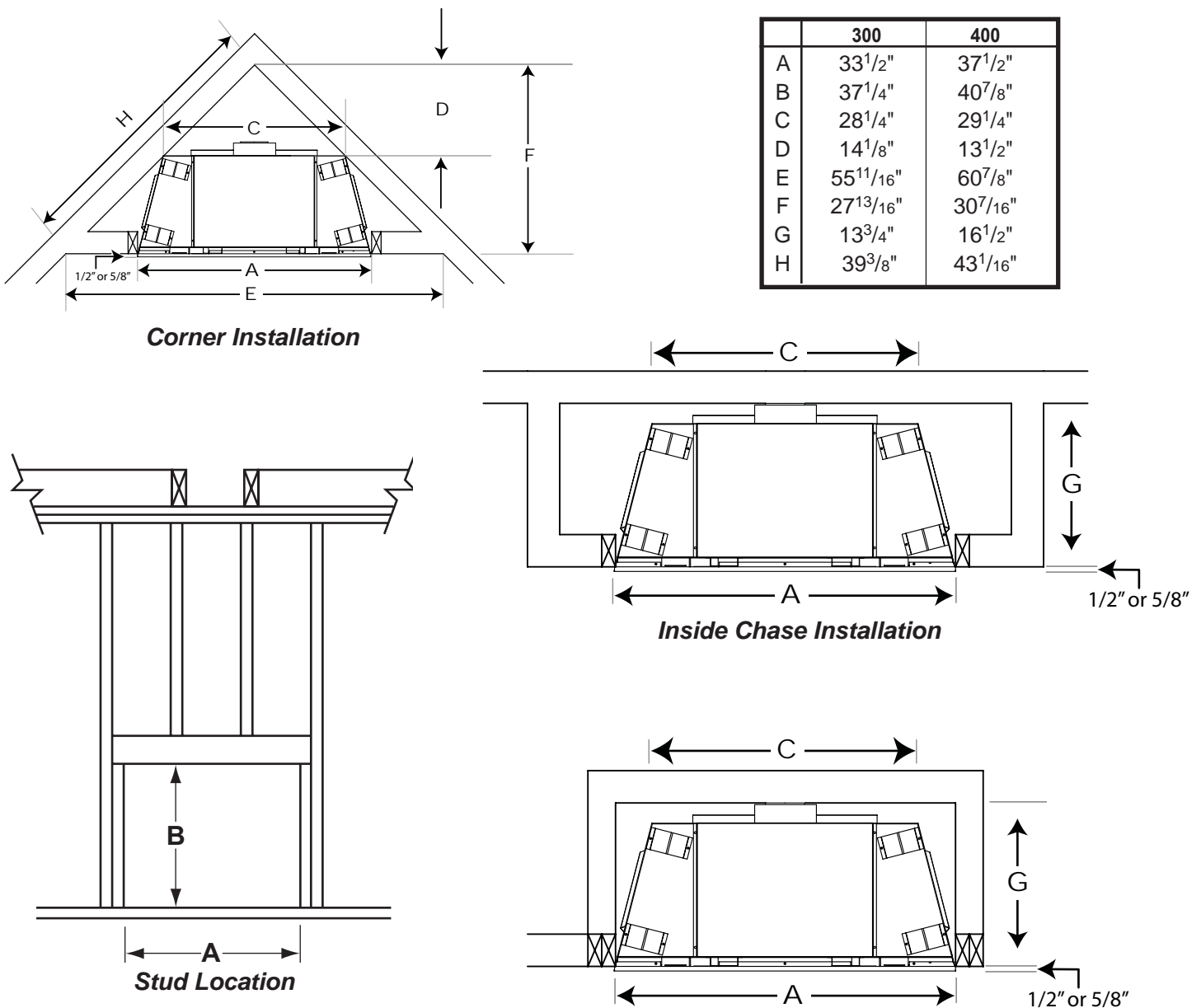

Figure 2 - Framing Dimensions

PRE-INSTALLATION INFORMATION

FIREPLACE DIMENSIONS

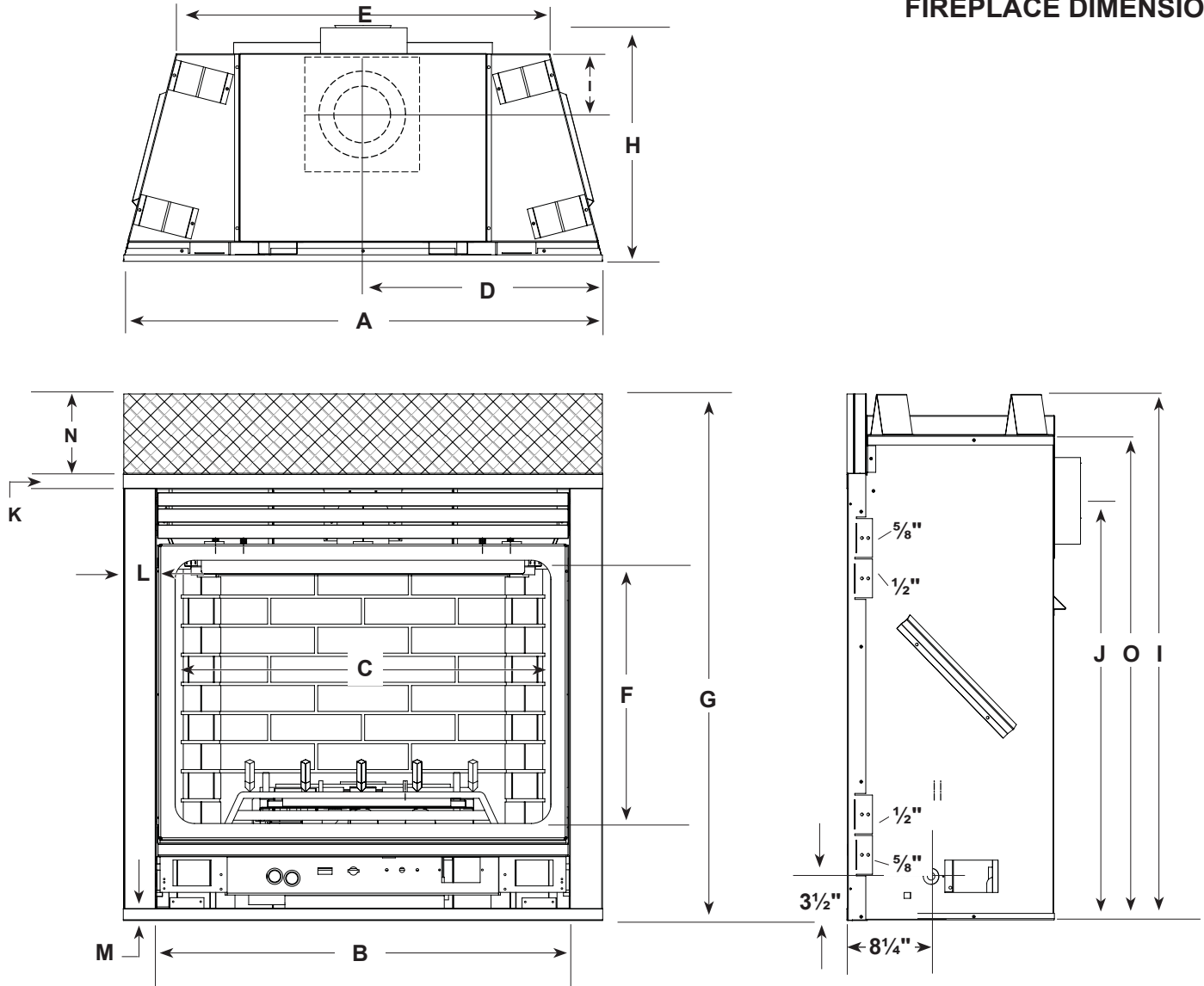

Figure 3 - Fireplace Dimensions

DESCRIPTION	Key Letter	HBDV300	HBDV400
Overall Front Width	A	33 ¹ / ₁₆ "	37 ¹ / ₁₆ "
Inside Width	B	29 ⁷ / ₈ "	32"
Glass Width	C	27"	29"
CTR Pipe Rear L/R	D	16 ¹ / ₂ "	18 ¹ / ₂ "
Rear Width	E	28"	29"
Glass Height	F	18"	20 ³ / ₈ "
Total Height	G	33 ⁷ / ₈ "	40 ⁵ / ₈ "
Depth	H	15"	18 ¹ / ₄ "

DESCRIPTION	Key Letter	HBDV300	HBDV400
Height to Standoffs	I	37"	40 ⁵ / ₈ "
CTR Pipe Height Rear	J	29 ⁵ / ₈ "	33 ¹ / ₈ "
Top Face	K	2 ¹ / ₈ "	1 ¹ / ₄ "
Side Face	L	1 ¹ / ₂ "	2 ¹ / ₂ "
Bottom Face	M	15 ¹⁵ / ₁₆ "	15 ¹⁵ / ₁₆ "
Non-combustible	N	5 ¹ / ₄ "	6 ¹ / ₈ "
Chassis Height	O	33 ³ / ₄ "	37 ¹ / ₂ "

FIREPLACE LOCATION

Plan for the installation of your appliance. This includes determining where the unit is to be installed, the vent configuration to be used, framing and finishing details, and whether any optional accessories (i.e. blower, wall switch, or remote control) are desired. Consult your local building code agency to ensure compliance with local codes, including permits and inspections.

The following factors should be taken into consideration:

- Clearance to side-wall, ceiling, woodwork, and windows. Minimum clearances to combustibles **must be maintained**.
- This fireplace may be installed along a wall, across a corner, or use an exterior chase. See Figure 4 for suggested locations.
- Location should be out of high traffic areas and away from furniture and draperies due to heat from appliance.
- Never obstruct the front opening of the fireplace.
- Do **not** install in the vicinity where gasoline or other flammable liquids may be stored.
- Vent pipe routing. See *Venting* section found in this manual for allowable venting configurations.
- These units can be installed in a bedroom. See National Fuel Gas Code ANSI Z233.1/NFPA 54 — (current edition), the Uniform Mechanical Code — (current edition), and Local Building Codes for specific installation requirements.

A	Flat on Wall
B	Cross Corner
C	Island**
D	Room Divider*
E	Flat on Wall Corner*
F	Chase Installation
Y	4" Minimum

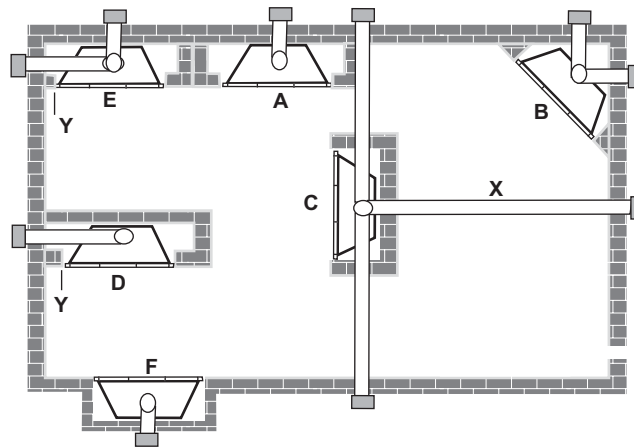

Figure 4 - Locating Gas Fireplace

** Island (C) and room divider (D) installation is possible as long as the horizontal portion of vent system (X) does not exceed 20'. See *Installing Horizontal Termination Configuration* on pages 18 and 19.

* When you install your fireplace in (D) room divider or (E) flat on wall corner positions (Y), a minimum of 6" clearance must be maintained from perpendicular wall and front of fireplace.

CLEARANCES

CLEARANCES TO COMBUSTIBLES

WARNING

Follow these instructions carefully to ensure safe installation. Failure to follow instructions exactly can create a fire hazard.

The appliance cannot be installed on a carpet, tile or other combustible material other than wood flooring. If installed on carpet or vinyl flooring, the appliance shall be installed on a metal, wood or noncombustible material panel extending full width and depth of the appliance.

NOTE

All mantel shelves, regardless of depth, should be a minimum of 12" from top opening of fireplace. Mantel shelf shall not exceed 12" maximum depth at 12" minimum height from opening.

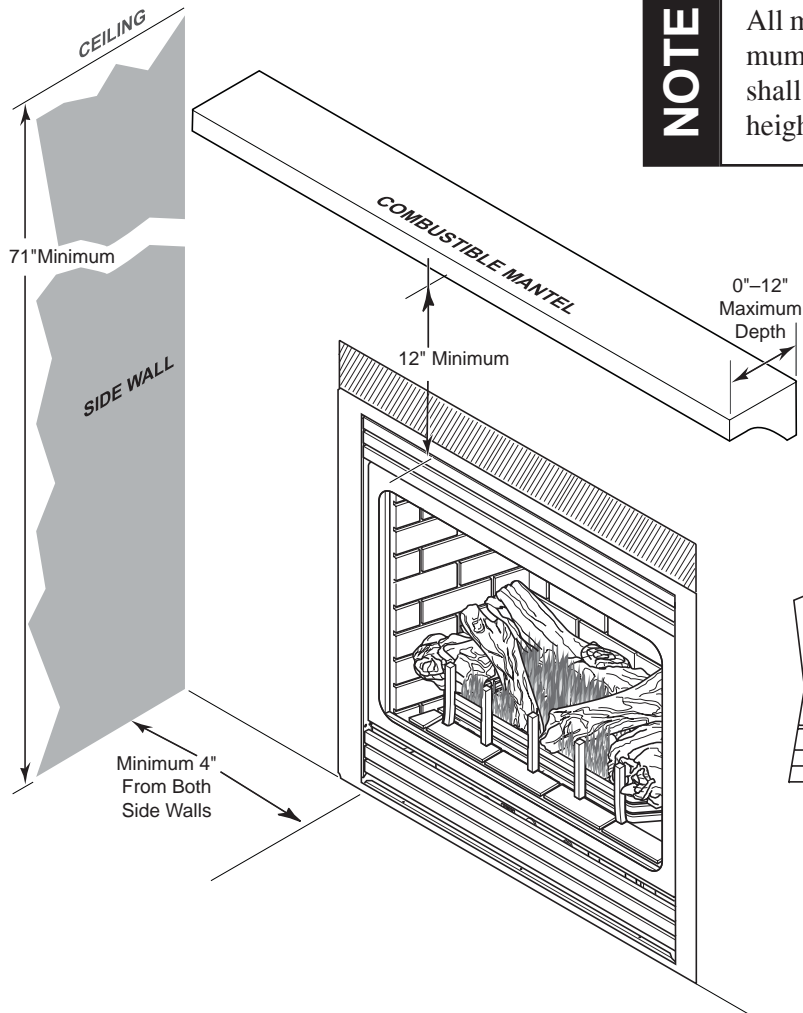

Figure 5 - Clearances

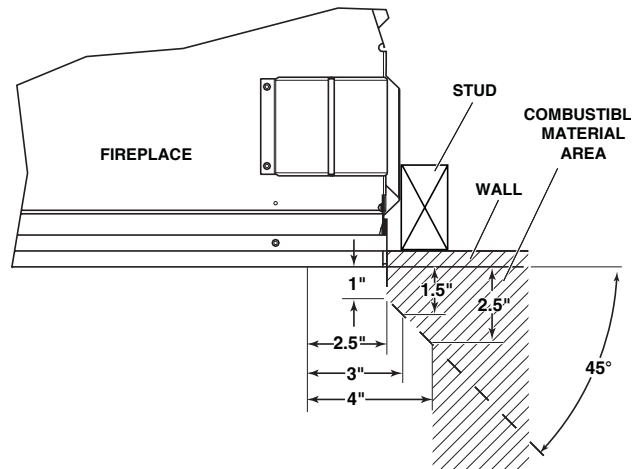

Figure 5a - Mantel clearances.

MANTEL CLEARANCES

NOTE: The combustible area above the facing must not protrude more than $\frac{3}{4}$ " from the facing. If it does, it is considered a mantel and must meet the mantel requirements listed in this manual.

SECURING FIREPLACE TO FLOOR OR FRAMING

The fireplace must be secured to the floor and/or to framing studs as shown in Figure 5. Use two (2) wood screws or masonry/concrete screws to secure fireplace to the floor. Use four (4) screws to attach fireplace to framing. The side nailing flanges are 1/2" or 5/8" to accommodate different wall thickness.

WARNING

**DO NOT REMOVE
INSULATION BOARD**

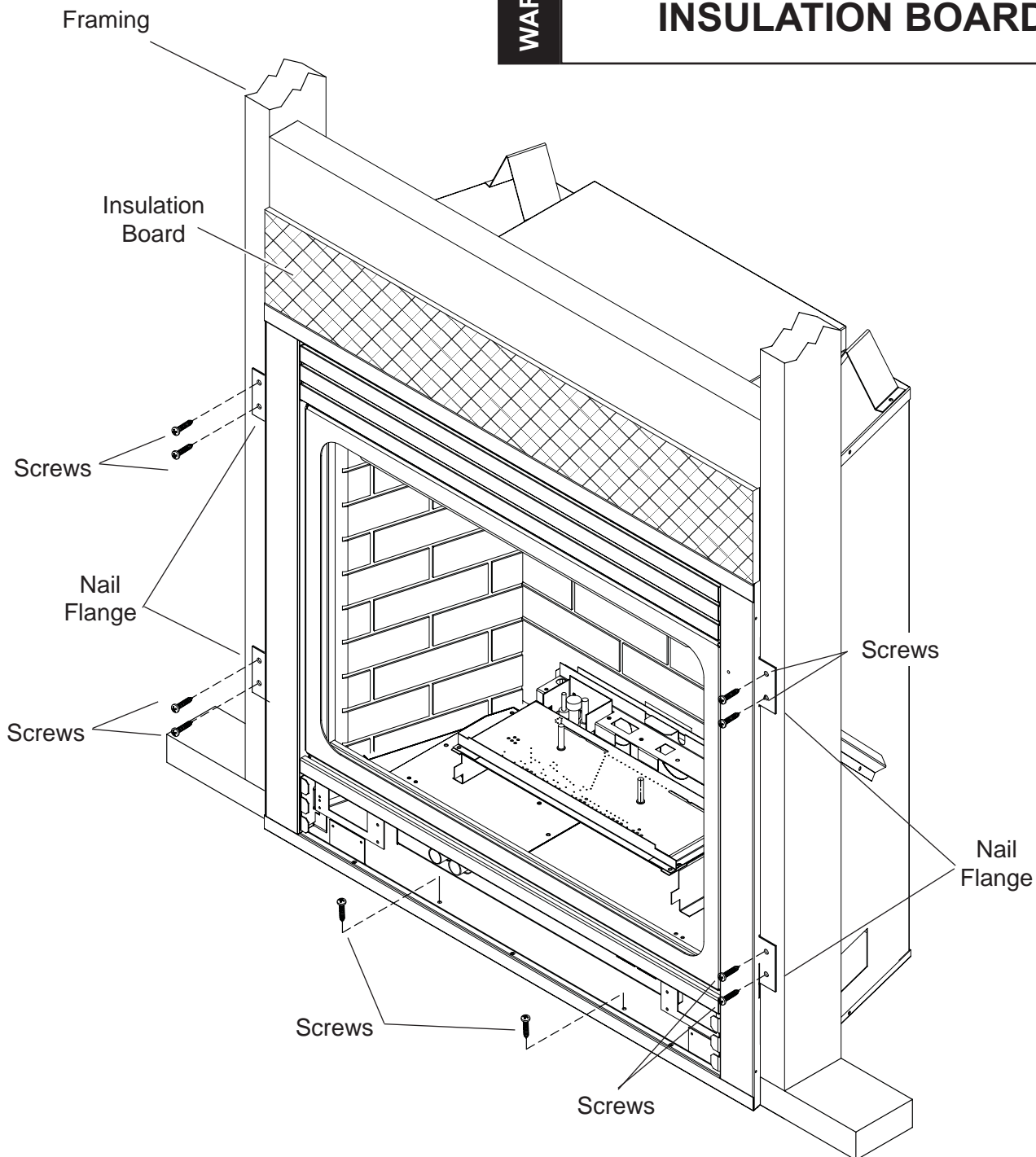

Figure 6 - Securing Fireplace to Floor and Framing Studs

INSTALLATION INFORMATION

FINISHING MATERIAL

NOTE: Any remote wiring (i.e. remote control, wall switch, and optional fan) must be done prior to final finishing to avoid costly reconstruction.

WARNING

Never obstruct or modify the air inlet or outlet grills (louvers). This may create a fire hazard.

Only noncombustible materials (i.e. brick, tile, slate, steel, or other materials with a UL fire rating of Zero) may be used to cover the black surface of the appliance. A 300°F minimum adhesive may be used to attach facing materials to the black surface. If joints between the finished wall and the fireplace surround are sealed, a 300°F minimum sealant material (General Electric RTV103 or equivalent) must be used.

WARNING

Read all instructions completely and thoroughly before attempting installation. Failure to do so could result in serious injury, property damage or loss of life. Operation of improperly installed and maintained venting system could result in serious injury, property damage or loss of life.

NOTICE

Failure to follow these instructions will void the warranty.

INSTALLATION PRECAUTIONS

Consult local building codes before beginning the installation. The installer must make sure to select the proper vent system for installation. Before installing vent kit, the installer must read this fireplace manual and vent kit instructions.

Only a qualified installer/service person should install venting system. The installer must follow these safety rules:

- Wear gloves and safety glasses for protection.
- Use extreme caution when using ladders or when on rooftops.
- Be aware of electrical wiring locations in walls and ceilings.

The following actions will void the warranty on your venting system:

- Installation of any damaged venting component.
- Unauthorized modification of the venting system.
- Installation of any component part not manufactured or approved by MHS.
- Installation other than permitted by these instructions.

WARNING

This fireplace must be vented to the outside. The venting system must **NEVER** be attached to a chimney serving a separate solid fuel burning appliance. Each gas appliance must use a separate vent system. Do not use common vent systems.

WARNING

Horizontal sections of this vent system require a minimum of 3" clearances to combustibles at the top of the flue and 1" clearance at the sides and bottom until the flue penetrates the outside wall. A minimum 1" clearance all around the flue is acceptable at this point of penetration.

Vertical sections of this vent system require a minimum of 1" clearance to combustibles on all sides of the pipe.

A Minimum of 3" Clearance to the Top Is Required Along Horizontal Length until Flue Pipe Penetrates Outside Wall.

A Minimum 1" Clearance to Combustibles Permitted All Around Flue at Outside Wall

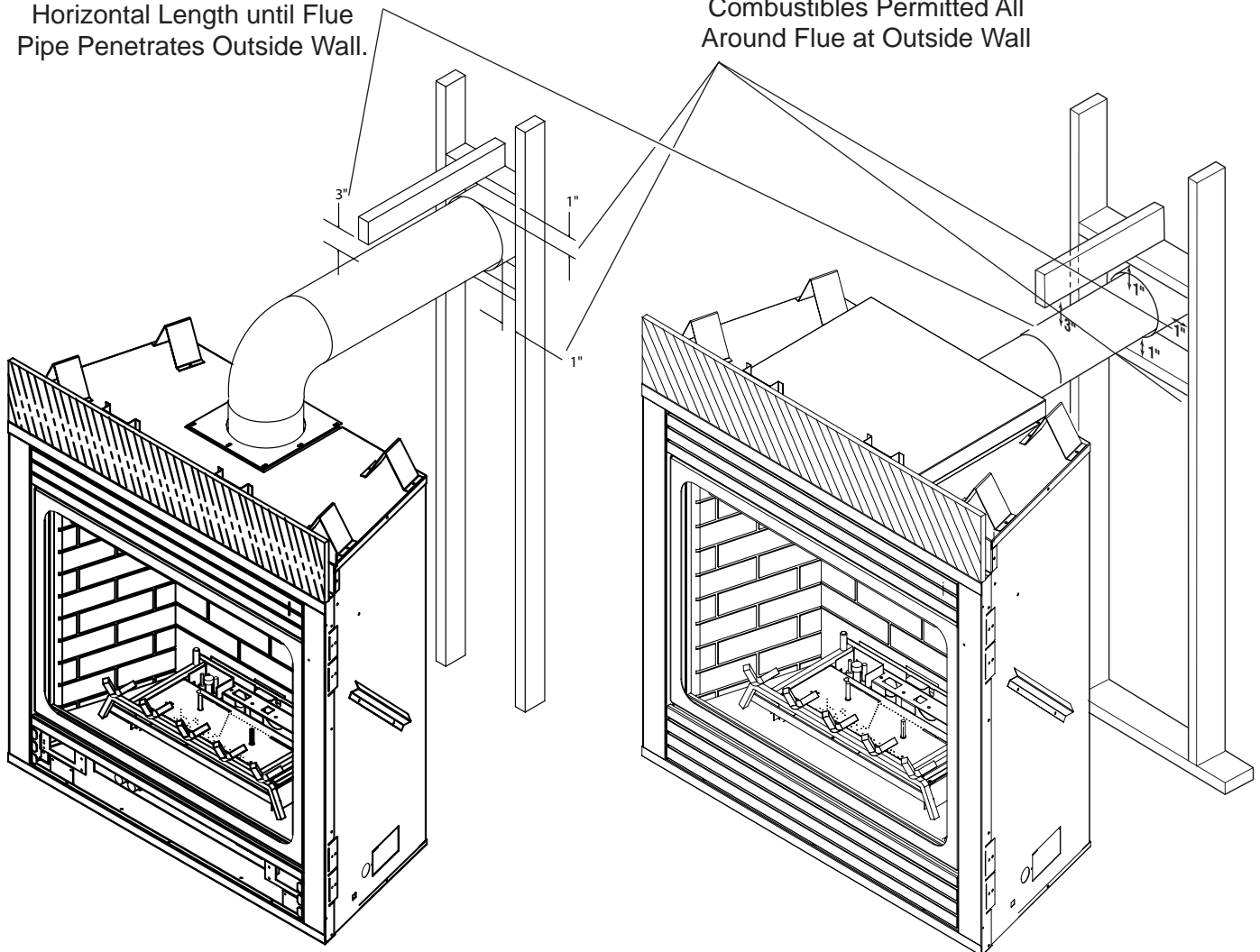

Figure 7 - Combustible Clearances for Vent Pipe

VENT INSTALLATION

OPTIONAL TOP VENT APPLICATION

The appliance is shipped as a rear vent unit. If the installation layout requires the unit to be a top vent configuration the appliance can be converted by following the steps below.

NOTE: REMOVE AND DISCARD TOP BOX AND INSULATION ON TOP OF THE UNIT BETWEEN THE STAND-OFFS. THIS BOX IS ONLY UTILIZED WITH REAR-VENT APPLICATIONS.

When removing and refitting the plates and adapter be sure the associated gaskets are undamaged and refitted as required.

1. Remove the eight (8) screws securing the flue pipe adapter to the fireplace body. *See Figure 9.*
2. Set the flue pipe adapter aside, complete with the gasket. Do not damage the gaskets as the adapter and gasket must be refitted.
3. Remove the eight (8) screws securing the flue pipe cover to the top of the intake box and remove the cover and gasket. *See Figure 9.*
4. Remove the six (6) screws securing the flue pipe to the back of the intake box and remove the pipe and gasket. *See Figure 10.*
5. Replace flue pipe to top of firebox. Ensure the gasket is in place and undamaged. Secure with six (6) screws. *See Figure 11.*
6. Place the flue pipe cover and gasket removed in step 3 over the flue opening in back of the intake box.
7. Refit the flue pipe adapter and gasket to the top of fireplace. Secure the adapter with eight (8) screws removed in step 1.

WARNING

After conversion to top vent configuration the 4" (100mm) flue pipe should be concentric within the 6⁵/₈" (175mm) outer collar (within 1/4").

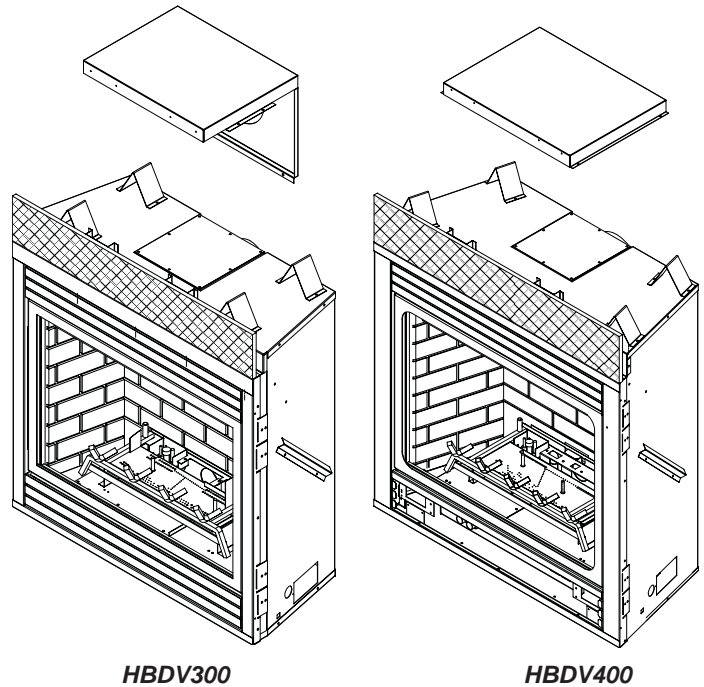

Figure 8 - Removing top box and insulation

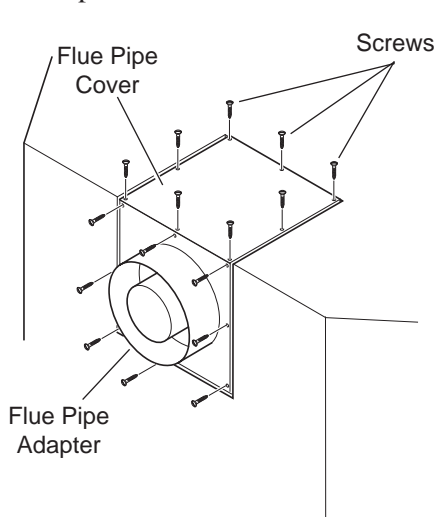

Figure 9 - Removing Screws from Flue Pipe Adapter and Flue Pipe Cover

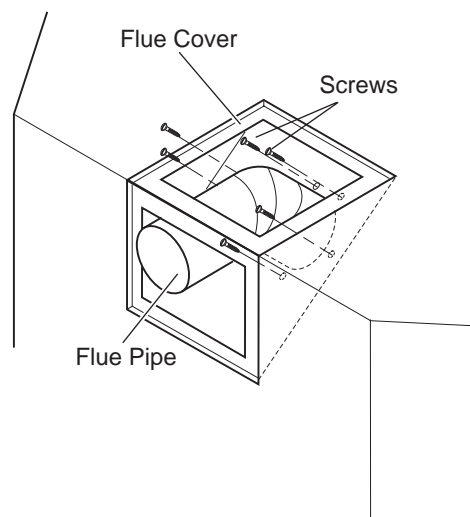

Figure 10 - Removing Flue Pipe

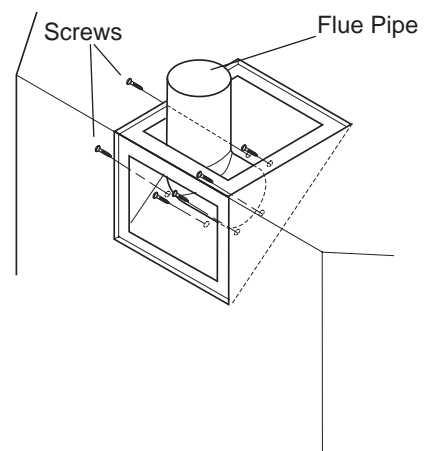

Figure 11 - Attaching Flue Pipe to Top Vent Configurations

INSTALLATION PLANNING

There are two basic types of direct-vent installation:

- Horizontal Termination
- Vertical Termination

It is important to select the proper length of vent pipe for the type of termination you choose. It is also important to note the wall thickness.

WARNING

Never run the vent pipe level or downward. This may cause excessive temperatures which could cause a fire.

FOR HORIZONTAL TERMINATION

Select the amount of vertical rise desired. All horizontal run of venting must have $\frac{1}{4}$ " rise for every 12" of run towards the termination.

You may use up to three 90° elbows in this vent configuration. See Horizontal Termination Configurations on pages 20 and 21.

FOR VERTICAL TERMINATION

Measure the distance from the fireplace floor to the ceiling. Add the ceiling thickness, the vertical rise in an attic or second story, and allow for sufficient vent height above the roof line.

NOTE: You may use two 45° elbows in place of a 90° elbow. You must follow rise to run ratios when using 45° elbows. The appliance is approved for use with three 90° elbows maximum or a combination of 90° and 45° elbows up to a maximum of 270°.

For two-story applications, firestops are required at each floor level. If an offset is needed in the attic, additional pipe and elbows will be required.

You may use a chase with a vent termination with exposed pipe on the exterior of the house. See Installing Vent System in a Chase below. If pipe is enclosed in chase, it is not exposed.

It is very important that the venting system maintain its balance between the combustion air intake and the flue gas exhaust. Certain limitations apply to vent configurations and must be strictly followed.

INSTALLING A VENT SYSTEM IN AN OUTSIDE CHASE

A chase is a vertical boxlike structure built to enclose venting that runs along the outside of a building. A chase is required for such venting.

NOTICE

Treatment of firestops and construction of the chase may vary from building type to building type. These instructions are not substitutes for the requirements of local building codes. You must follow all local building codes.

NOTICE

When installing in a chase, you should insulate the chase as you would the outside walls of your home. This is especially important in cold climates. Insulation should be considered a combustible material. Maintain proper clearances to all combustible materials.

VENT INSTALLATION

FOR HORIZONTAL TERMINATION

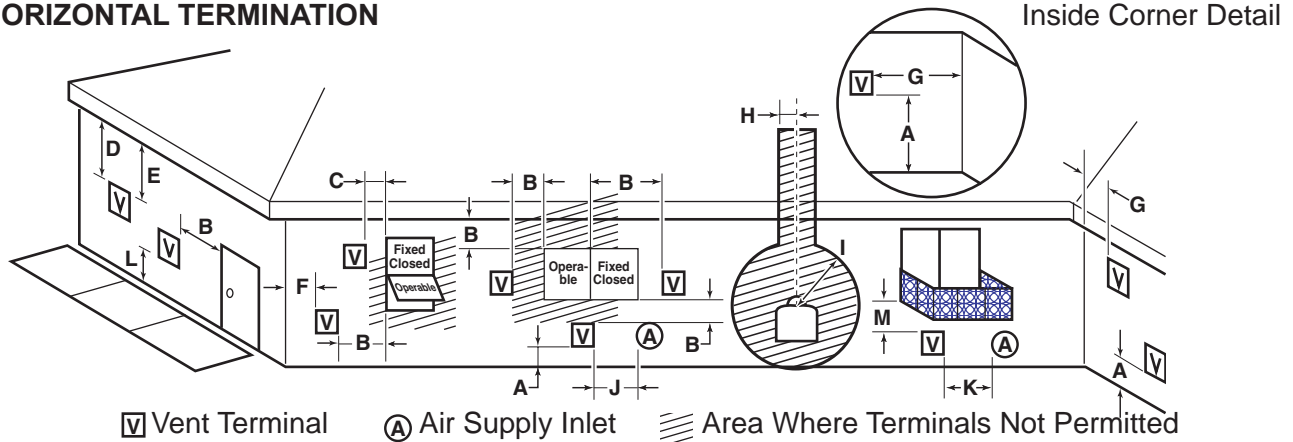

Figure 12 - Horizontal Vent Termination Location

MINIMUM DISTANCES

- A = Clearance above the grade, a veranda, porch, deck, or balcony [*12" (305mm) minimum].
 - B = Clearance to window or door that may be opened [*12" (305mm) minimum].
 - C = Clearance to permanently closed window [*minimum 12" (305mm) recommended to prevent condensation on window]
 - D = Vertical clearance to ventilated soffit located above the terminal within a horizontal distance of two (2) feet (610mm) from the centerline of the terminal [18" (457mm) minimum].
 - E = Clearance to unventilated soffits [12" (305mm) minimum]. Clearance to vinyl soffit [30" (762mm)].
 - F = Clearance to an outside corner. See Figure 12.
 - G = Clearance to an inside corner. See Figure 12.
 - H = *Not to be installed above a gas meter/regulator assembly within three (3) feet (914mm) horizontally from the centerline of the regulator.
 - I = Clearance to service regulator vent outlet [*3' (914mm) minimum].
 - J = Clearance to non-mechanical air supply inlet to building or the combustion air inlet to any other appliance [*12" (305mm) minimum].
 - K = Clearance to a mechanical air supply inlet [*6' (1829mm) minimum].
 - L = Clearance above a paved sidewalk or paved driveway located on public property [*7' (2133mm) minimum].
 - M = Clearance under veranda, porch, deck, or balcony. **See Figure 13, page 17.** [For Canada *12" (305mm) minimum ***].
- * As specified in CAN/CGA B149 Installation Codes. Note: Local codes or regulations may require different clearances.
- ** A vent must not terminate directly above a sidewalk or paved driveway, which is located between two single-family dwellings and serves both dwellings.

WARNING

Always maintain minimum clearances around vent systems. The minimum clearances to combustibles for horizontal vent pipe are 3" at the top and 1" at the sides and bottom of the vent system until the pipe penetrates the nearest vertical wall (1" required). A 1" minimum clearance all around the pipe must be maintained at outside wall and on vertical runs. Do not pack the open air spaces with insulation or other materials. This could cause high temperatures and may present a fire hazard.

TERMINATION CLEARANCES FOR BUILDINGS WITH COMBUSTIBLE AND NONCOMBUSTIBLE EXTERIORS

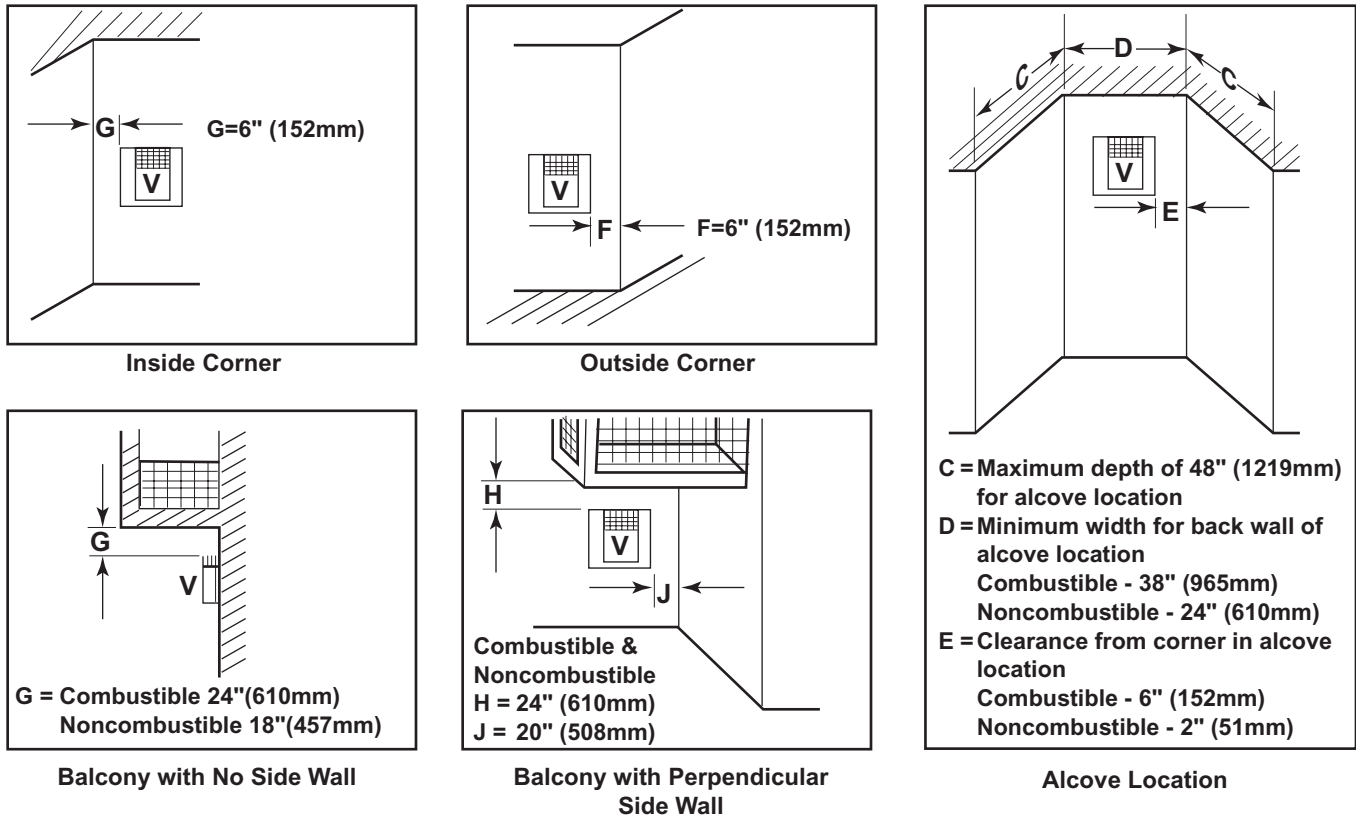

Figure 13 - Allowable Venting Chart

HOW TO USE THE VENT GRAPH

The Vent Graph should be read in conjunction with the following vent installation instructions to determine the relationship between the vertical and horizontal dimensions of the vent system.

1. Determine the height of the center of the horizontal vent pipe exiting through the outer wall. Using this dimension on the Sidewall Vent Graph below, locate the point intersecting with the slanted graph line.
2. From the point of this intersection, draw a vertical line to the bottom of the graph.
3. Select the indicated dimension, and position the fireplace in accordance with same.

Example: If the vertical dimension from the floor of the fireplace is 11' (3.4m) the horizontal run to the face of the outer wall must not exceed 14' (4.3m).

Example: If the vertical dimension from the floor of the unit is 7' (2.14m), the horizontal run to the face of the outer wall must not exceed 8½' (2.6m).

Sidewall Vent Graph showing the relationship between vertical and horizontal dimensions for a Direct Vent flue system.

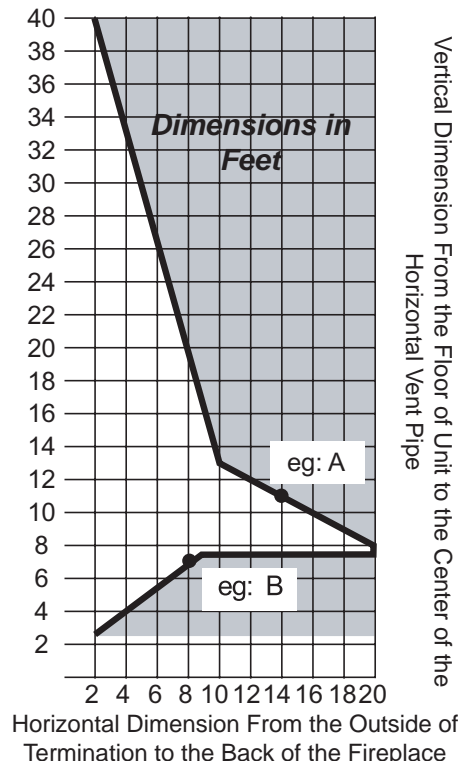

Figure 13 - Rear Wall Venting Graph

VENTING INSTALLATION

REAR (THROUGH THE WALL) APPLICATIONS

When installed as a rear vent unit this appliance may be vented directly to a termination located on the rear wall behind the appliance

- The maximum horizontal distance between the rear of the appliance and the outside of termination is 20" (508 mm). See *Figure 15*.
- Only one 45° elbow is allowed in these installations.

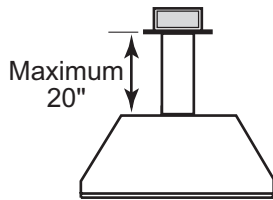

Top View Flat Installation

Figure 15 - Rear Vent Application, Maximum Horizontal Distance

Sealant is not required to assemble HBDV/DVBH fireplace venting. Do not use silicone sealant at the flue exhaust connections.

1. Find the pipe section's direction label. The label arrow shall be pointed away from the firebox and toward the termination. Firmly insert the initial rigid section/elbow into the firebox outer collar. Simpson "GS" and Selkirk "DT" outer walls are hemmed and will snap into the collar's tabs. Attach Simpson's DirectVent Pro by fully inserting into the collar and securing with self tapping screws. The screws shall only penetrate the flue outer wall.

Refer to vent manufacturer's installation instructions to properly assemble flue.

2. Locate and cut the vent opening in the wall. For combustible walls first frame in opening.

Combustible Interior Walls: Cut a 11½"H x 9½" W hole through the interior wall.

Combustible Exterior Walls: Cut a 9½"H x 9½"W square hole through the exterior wall frame. See *Figure 17*.

Noncombustible Walls: Hole opening should be 7½" (190mm) in diameter.

3. The center of the hole should line up with the center line of the horizontal rigid vent pipe end. Pipe shall always run level or uphill on horizontal runs. Never run pipe down hill. See *Figure 17*.

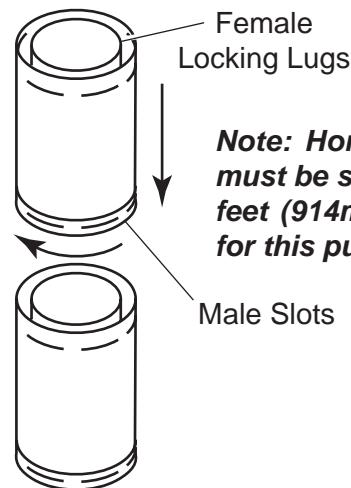

Figure 16 - Rigid Vent Pipe Connections

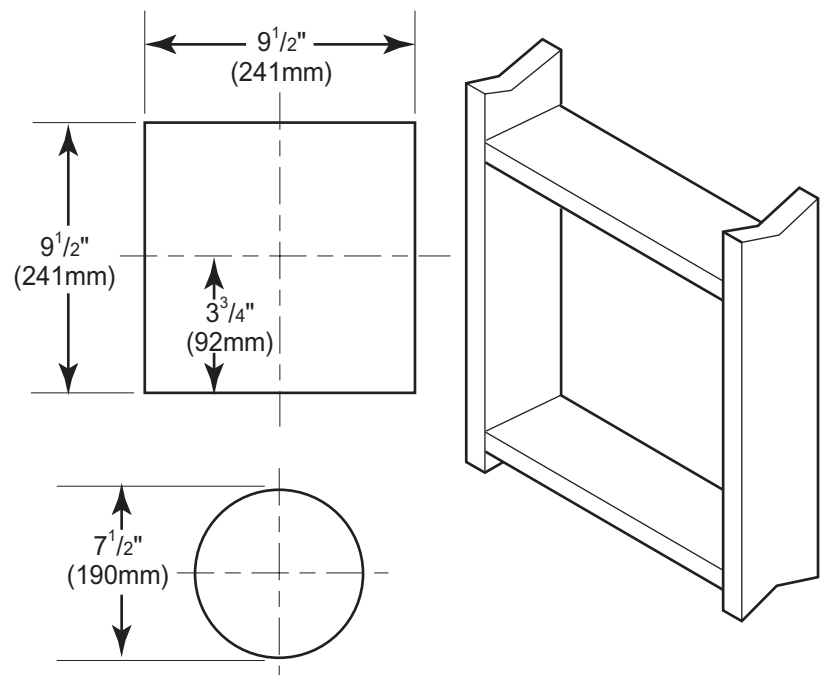

Figure 17 - Exterior Wall Framing Dimensions

REAR WALL VENT INSTALLATION (continued)

4. Apply a bead of non-hardening mastic around the outside edge of vent cap. Position the vent cap in the center of hole on the exterior wall with the word "HOT" on the vent cap facing up. Insure proper clearance of 1" to combustibles is maintained to the flue. Attach the vent cap with four wood screws supplied. See Figure 18.

WARNING

Do not recess vent termination into any wall. This will cause a fire hazard.

NOTE: Replace the wood screws with appropriate fasteners for stucco, brick, concrete, or other types of siding.

A vinyl siding standoff (part #950) must be used with the Simpson/Selkirk Horizontal Termination (part #985) on vinyl, stucco or wood-clad exterior walls. Apply non-hardening mastic around outside edge of the standoff instead of the vent cap assembly. See Figure 19.

5. Slide the firestop over the vent pipe before connecting the horizontal run to the vent cap. See Figure 20.
6. The termination should overlap the flue a minimum of 1¹/₄" Apply silicone to the outer pipe/termination connection. Fasten termination with screws provided.
7. Slide the firestop against the interior wall surface and attach with screws. See Figure 20.

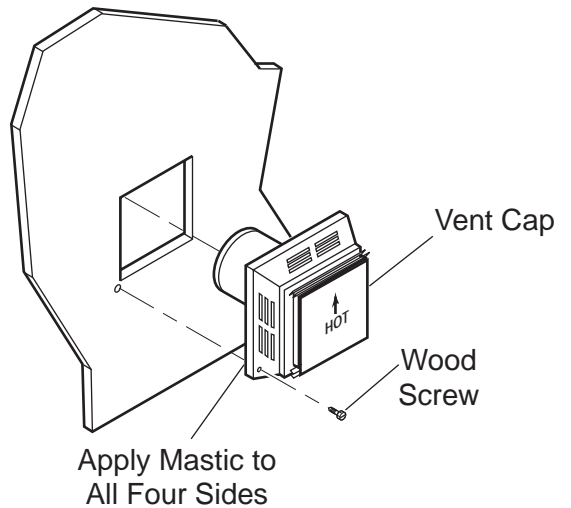

Figure 18 - Installing Horizontal Termination

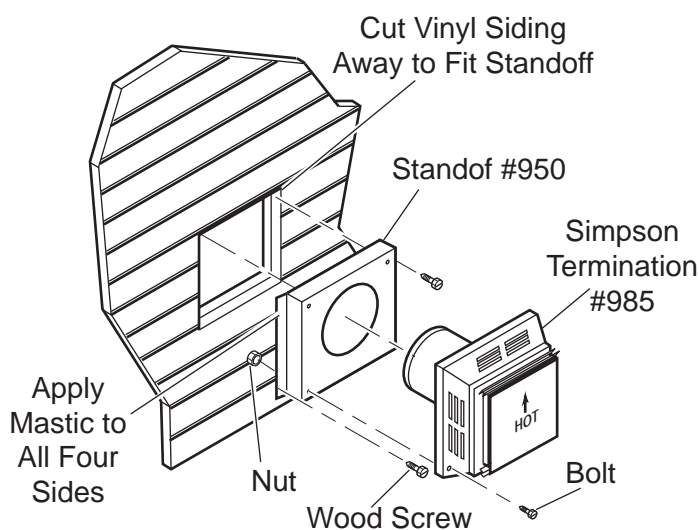

Figure 19 - Installing Simpson/Selkirk Vinyl Siding Standoff and Termination

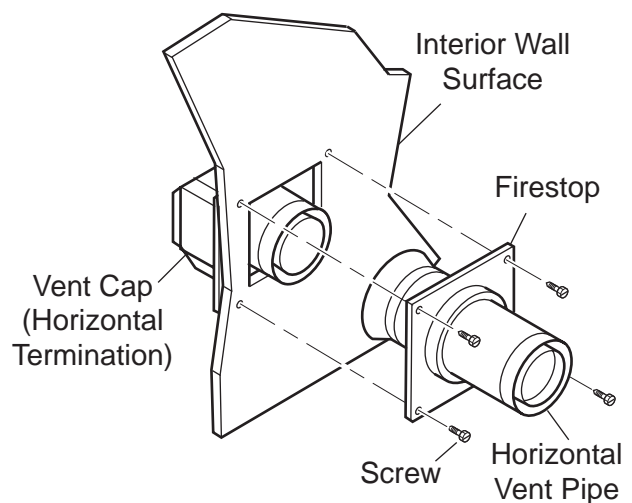

Figure 20 - Installing Firestop on Horizontal Vent Pipe

VENT INSTALLATION

HORIZONTAL TERMINATION CONFIGURATIONS

Since it is very important that the venting system maintain its balance between the combustion air intake and the flue gas exhaust, certain limitations as to vent configurations apply and must be strictly adhered to.

The Vent Graph, showing the relationship between vertical and horizontal side wall venting, will help to determine the various dimensions allowable. See Figure 13, page 17.

NOTE: Horizontal sections of this vent system require a minimum of 3" clearances to combustibles at the top of the flue and 1" clearance at the sides and bottom until the flue penetrates the outside wall. A minimum 1" clearance all around the flue is acceptable at this point of penetration.

Vertical sections of this vent system require a minimum of 1" clearance to combustibles on all sides of the pipe.

When vent exits through foundations less than 20" below outcrop, the termination must be flush up with outcropped wall above.

It is best to locate the fireplace in such a way that minimizes the number of offsets and horizontal vent length.

The horizontal vent run refers to the total length of vent pipe from the flue collar of the fireplace (or the top of the Transition Elbow) to the face of the outer wall.

WARNING When installing the appliance as a rear vent unit, the 90° or 45° transition elbow attached directly to the rear of the unit is NOT INCLUDED in the following criteria and calculations, and unless specifically mentioned should be ignored when calculating venting layouts.

- The maximum number of 90° elbows per side wall installation is three (3). See Figure 21.
- If a 90° elbow is fitted directly on top of the fireplace flange the maximum horizontal vent run before the termination or a vertical rise is 36" (914 mm). See Figure 22.

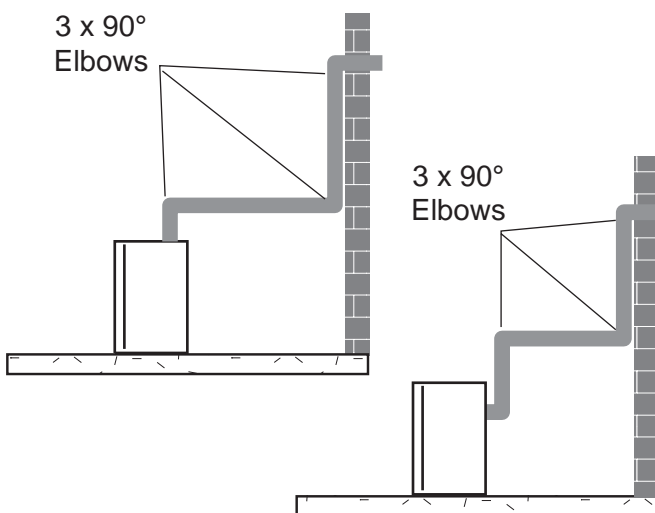

Figure 21 - Maximum Three (3) 90° Elbows Per Installation

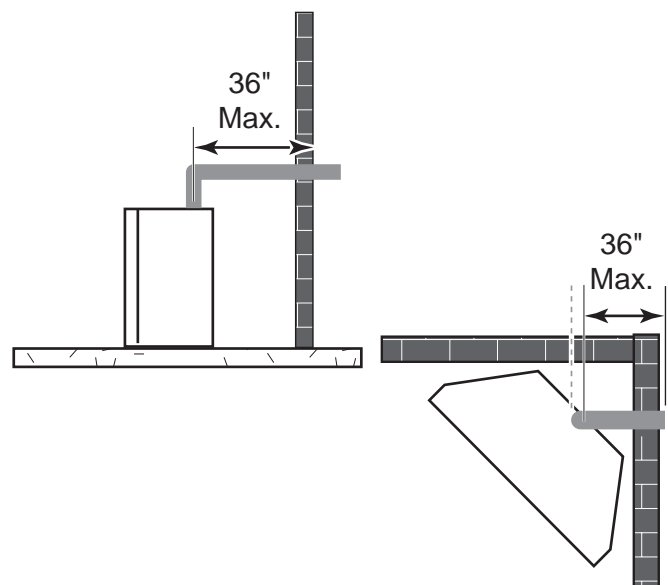

Figure 22 - Maximum Horizontal Run with No Rise

HORIZONTAL TERMINATION CONFIGURATION

(Continued)

- If a 90° elbow is used in the horizontal vent run (level height maintained) the horizontal vent length is reduced by 36". See Figures 21 and 22, page 20. This does not apply if the 90° elbows are used to increase or redirect a vertical rise. See Figure 24.

Example: According to the vent graph (page 17) the maximum horizontal vent length in a system with a 7.5' vertical rise is 20' (6m) and if a 90° elbow is required in the horizontal vent it must be reduced to 17' (5.2 m).

In Figures 23 and 24, Dimension A plus B must not be greater than 17' (5.2m).

- The maximum number of 45° elbows permitted per side wall installation is two (2). These elbows can be installed in either the vertical or horizontal run.
- For each 45° elbow installed in the horizontal run, the length of the horizontal run **MUST** be reduced by 18" (45cm). This does not apply if the 45° elbows are installed on the vertical part of the vent system.
- The maximum number of elbow degrees in a system is 270°. See Figure 25.

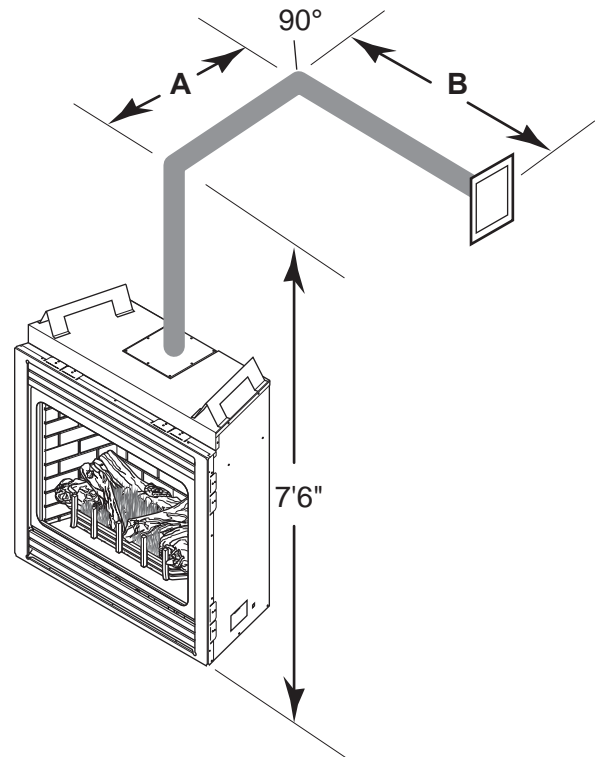

Figure 23 - Horizontal Run Reduction

Example:

Elbow 1 =	90°
Elbow 2 =	45°
Elbow 3 =	45°
Elbow 4 =	90°
<hr/>	
Total Angular Variation =	270°

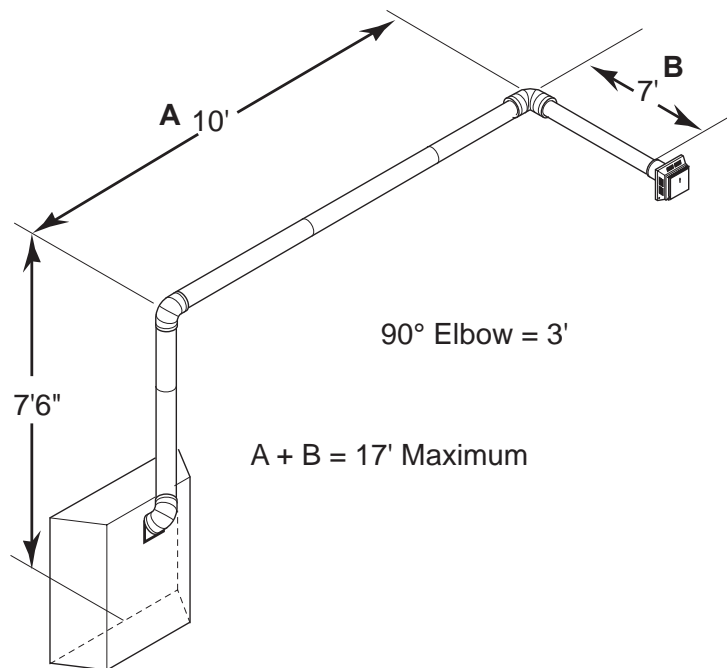

Figure 24 - Maximum Vent Run with Elbows

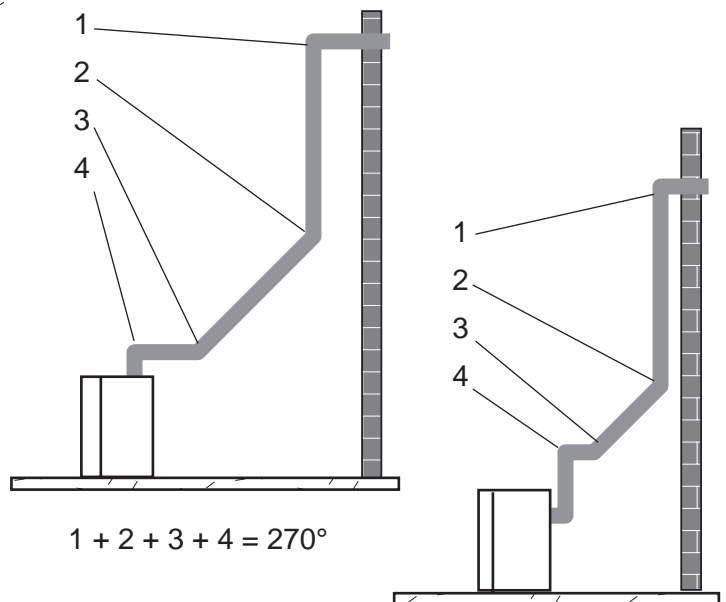

Figure 25 - Maximum Elbow Usage

VENT INSTALLATION

BELOW GRADE INSTALLATIONS

When it is not possible to meet the required vent terminal clearances of 12" above grade level, a snorkel kit is recommended. It allows installation depth down to 7" (178mm) below grade level. The 7" (178mm) is measured from the center of the horizontal vent pipe as it penetrates through the wall.

Ensure that sidewall venting clearances are observed. If venting system is installed below ground, we recommend a window well with adequate and proper drainage to be installed around the termination area.

If installing a snorkel, a minimum 24" vertical rise is necessary. The maximum horizontal run with the 24" vertical pipe is 36". This measurement is taken from the collar of the fireplace (or transition elbow) to the face of the exterior wall. See the Sidewall Venting Graph for extended horizontal run if the vertical exceeds 24".

1. Establish vent hole through the wall. *See Figure 16, page 18.*
2. Remove soil to a depth of approximately 16" below base of snorkel. Install drain pipe. Install window well (not supplied). Refill hole with 12" of coarse gravel leaving a clearance of approximately 4" below snorkel. *See Figure 26.*
3. Install vent system.
4. Ensure a watertight seal is made around the vent pipe coming through the wall.
5. Apply high temperature sealant caulking (supplied) around the 4" and 7" snorkel collars.
6. Slide the snorkel into the vent pipes and secure to the wall.
7. Level the soil so as to maintain a 4" clearance below snorkel. *See Figure 26.*

WARNING

- Do not back fill around snorkel.
- A clearance of at least 4" must be maintained between the snorkel and the soil.

If the foundation is recessed, use recess brackets (not supplied) for securing lower portion of the snorkel. Fasten brackets to wall first, then secure to snorkel with self drilling #8x¹/₂ sheet metal screws. It will be necessary to extend vent pipes out as far as the protruding wall face. *See Figure 27.*

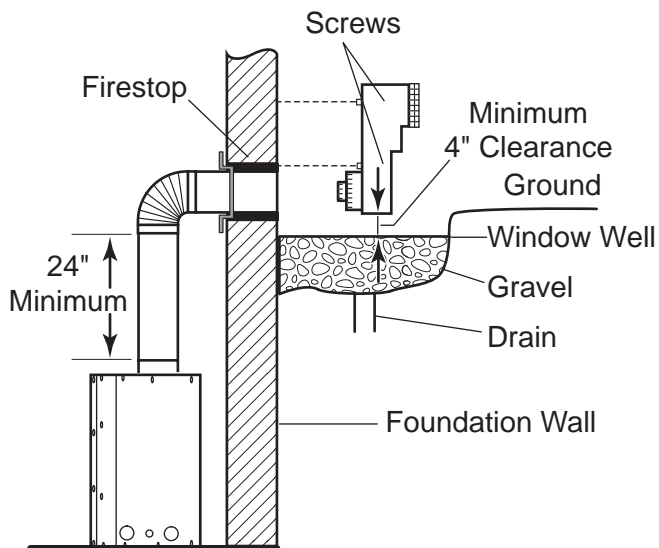

Figure 26 - Below Grade Installation

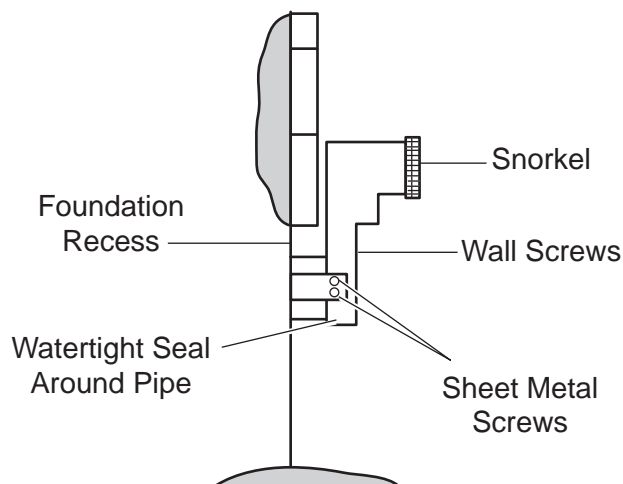

Figure 27 - Snorkel Installation, Recessed Foundation

VERTICAL (THROUGH-THE-ROOF) APPLICATIONS

This Gas Fireplace has been approved for,

- Vertical installations up to 40' (12m) in height. Up to a 10' (3m) horizontal vent run can be installed within the vent system using a maximum of two 90° elbows. See Figure 28.

NOTE: Horizontal sections of this vent system require a minimum of 3" clearances to combustibles at the top of the flue and 1" clearance at the sides and bottom until the flue penetrates the outside wall. A minimum 1" clearance all around the flue is acceptable at this point of penetration.

Vertical sections of this vent system require a minimum of 1" clearance to combustibles on all sides of the pipe.

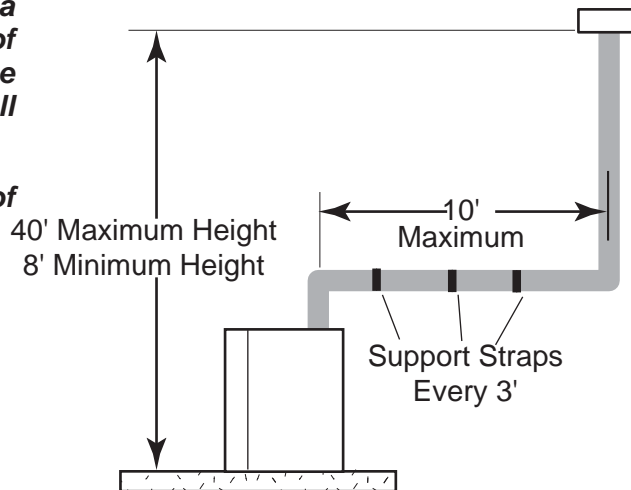
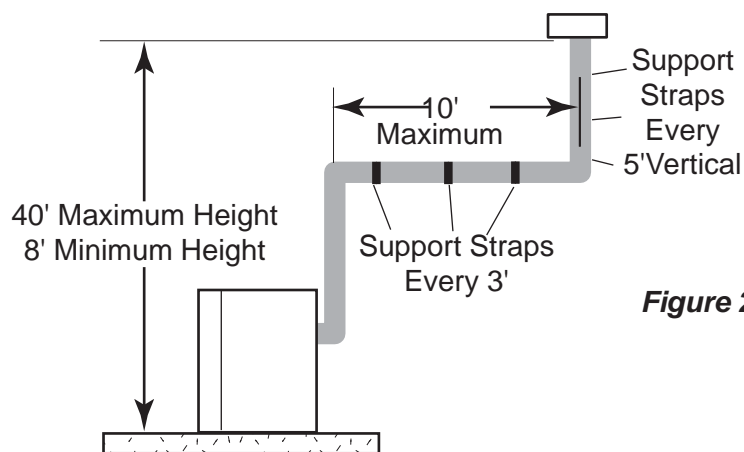

Figure 28 - Support Straps for Horizontal Runs

- Up to two 45° elbows may be used within the horizontal run. For each 45° elbow used on the horizontal plane, the maximum horizontal length must be reduced by 18" (450mm).

Example: Maximum horizontal length

No elbows = 10' (3m)

1x45° elbows = 8.5' (2.6m)

2x45° elbows = 7' (2.1m)

- A minimum of an 8' (2.5m) vertical rise is required.
- Two sets of 45°elbows offsets may be used within the vertical sections. From 0 to a maximum of 8' (2.5 m) of vent pipe can be used between elbows. See Figure 29.
- The maximum angular variation allowed in the system is 270°. See Figure 29.

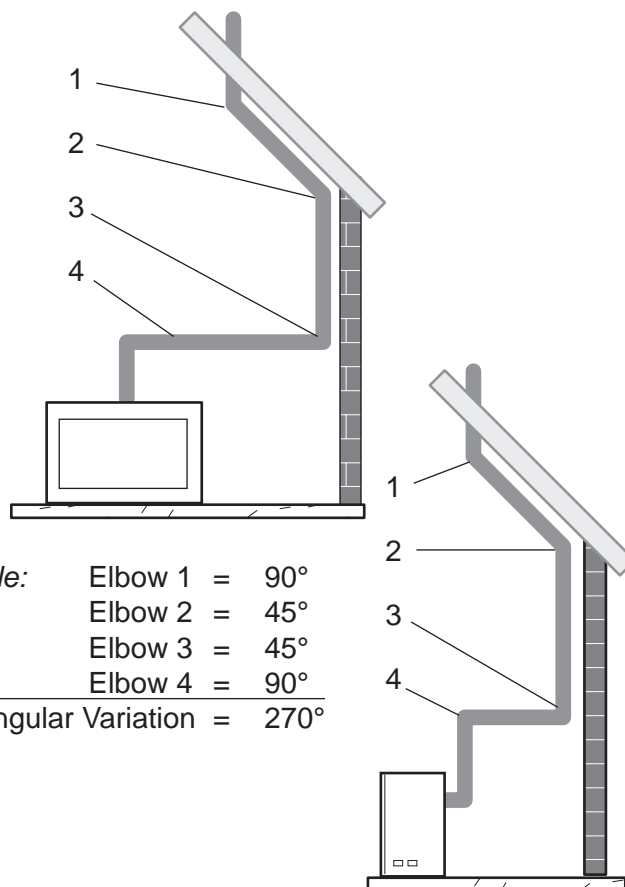

Example:

Elbow 1	=	90°
Elbow 2	=	45°
Elbow 3	=	45°
Elbow 4	=	90°
<hr/>		
Total Angular Variation	=	270°

Figure 29 - Maximum Elbow Usage

VENT INSTALLATION

INSTALLATION FOR VERTICAL TERMINATION

1. Determine the route your vertical venting will take. If ceiling joist, roof rafters or other framing will obstruct the venting system, consider an offset. See *Figure 30* to avoid cutting load bearing members.

For optimal flame appearance, a restrictor disk is necessary on straight vertical runs of 20' or more.

- Runs may not incorporate elbows.
- The disk is part number 45D0551 and is included in installation manual packet.
- Drop the disk into a 4" inner collar before installing the first section of flue or install at the last section before installing the termination.
- An additional disk may be installed on runs of 35' or more. Rotate disks perpendicular to each other.

NOTE: Pay special attention to these installation instructions for required clearances (air space) to combustibles when passing through ceilings, walls, roofs, enclosures, attic rafters, etc. Do not pack air spaces with insulation. Also note maximum vertical rise of the venting system and any maximum horizontal offset limitations. Offsets must fall within the parameters shows in *Figure 13*, page 20.

2. Set fireplace in desired location. Drop a line plumb down from the ceiling to the position of the flue exit. Mark the center point where the vent will penetrate the ceiling. Drill a small locating hole at this point.

Drop a plumb line from the inside of the roof to the ceiling locating hole in the ceiling. Mark the center point where the vent will penetrate the roof. Drill a small locating hole at this point.

FLAT CEILING INSTALLATION

1. Cut a 9 $\frac{1}{2}$ " (241 mm) square hole in the ceiling using the locating hole as a center point. The opening should be framed to 9 $\frac{1}{2}$ " x 9 $\frac{1}{2}$ " (241 mm x 241 mm) inside dimensions as shown in *Figure 32* using framing lumber the same size as the ceiling joist. If the area above the ceiling is an insulated ceiling or a room, nail firestop from the top side. This prevents loose insulation from falling into the required clearance space. See *Figure 31*. Otherwise, install firestop below the framed hole. See *Figure 32*.
2. Assemble the desired lengths of pipe and elbows necessary to reach from the burner system flue up through the firestop. Be sure pipe and elbow connections are fully twist-locked. See *Figure 15*, page 18.

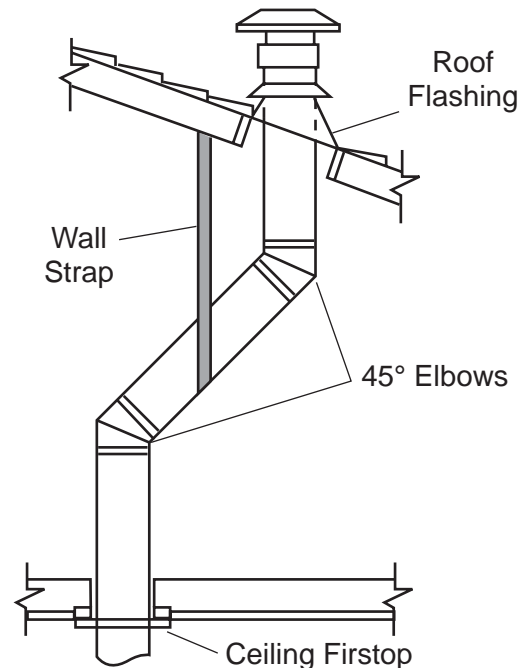

Figure 30 - Offset with Wall Strap and 45° Elbows

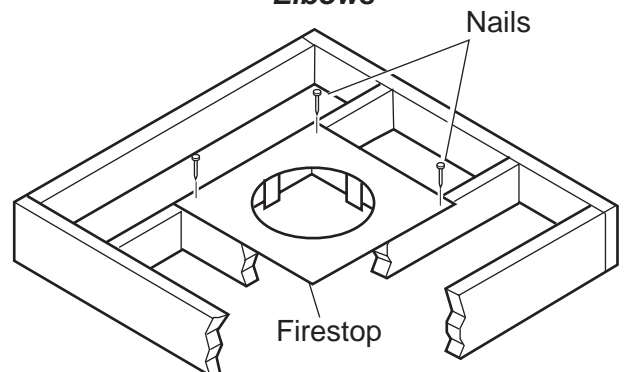

Figure 31 - If Area Above is a Room, Install Firestop above Framed Hole as Shown

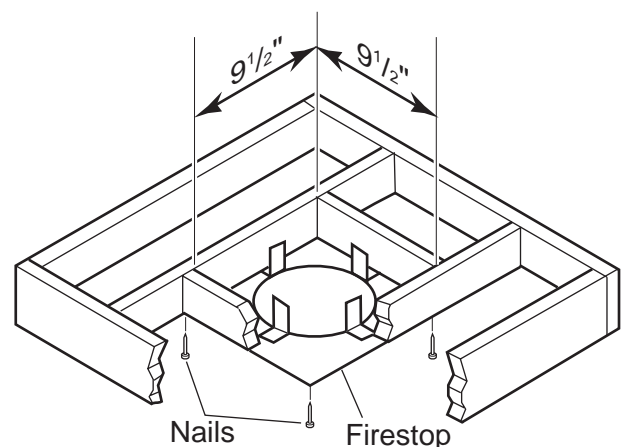

Figure 32 - If Area Above is Not a Room, Install Firestop below Framed Hole as Shown

3. Cut a hole in the roof using the locating hole as a center point. (Cover any exposed open vent pipes before cutting hole in roof). The 9¹/₂"x9¹/₂" (241mm x 241mm) hole must be measured on the horizontal. Actual length may be larger depending on the pitch of the roof. There must be a 1" minimum clearance from the vent pipe to combustible materials. (Insulation should be considered a combustible material).
4. Connect a section of pipe and extend up through the hole.

NOTE: If an offset is needed to avoid obstructions, you must support the vent pipe every three (3) feet. Use wall straps for this purpose. See Figure 28, page 23. Whenever possible, use 45° elbows instead of 90° elbows. The 45° elbow offers less restriction to the flow of the flue gases and intake air.

5. Place the flashing over the pipe section(s) extending through the roof. Secure the base of the flashing to the roof and framing with roofing nails. Be sure roofing material overlaps the top edge of the flashing. There must be a 1" clearance from the vent pipe to combustible materials.
6. Continue to add pipe sections until the height of the vent cap meets the minimum building code requirements.

NOTE: You must increase vent height for steep roof pitches. Nearby trees, adjoining roof lines, steep pitched roofs, and other similar factors may cause poor draft or down-drafting in high winds. Increasing the vent height may solve this problem.

NOTE: If the vent pipe passes through any occupied areas above the first floor, including storage spaces and closets, you must enclose pipe. You may frame and sheetrock the enclosure with standard construction material. Make sure to meet the minimum allowable clearances to combustibles. Do not fill any of the required clearance spaces with insulation.

CATHEDRAL CEILING INSTALLATION

1. Remove shingles or other roof covering as necessary to cut the rectangular hole for the support box. Mark the outline of the cathedral ceiling support box on the roof sheathing using the locating hole as a center point.
2. Cut the hole 1/8" larger than the support box outline. See Figure 32.
3. Lower the support box through the hole in the roof until the bottom of the box extends at least 2" below the ceiling. See Figure 32. Align the support box vertically and horizontally using a level. Temporarily tack the support box in place through the inside walls and into the roof sheathing.
4. Using tin snips, cut the support box from the top corners down to the roof line and fold the resulting flaps over the roof sheathing. See Figure 33. Apply a bead of non-hardening, mastic around the top edges of the support box to make a seal between the box and the roof. Nail in place with roofing nails. Remove any combustible material that might be inside the support box.
5. Complete the cathedral ceiling installation by following the same procedures outlines in steps 2 through 6 for Flat Ceiling Installation, page 24 and above.

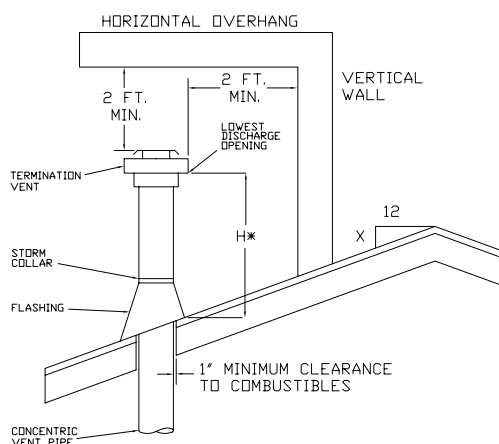

ROOF PITCH	H (feet)
Flat to 6/12	1.0
Over 6/12 to 7/12	1.25
Over 7/12 to 8/12	1.5
Over 8/12 to 9/12	2.0
Over 9/12 to 10/12	2.5
Over 10/12 to 11/12	3.25
Over 11/12 to 12/12	4.0

*H = Minimum height from roof to lowest discharge opening of vent.

Figure 33 - Minimum chimney clearance

FLEX VENT INSTALLATION

1. Flexible UL1777 listed venting may be used in any venting application where rigid direct vent components can be used. **All restrictions, clearances and allowances that pertain to the rigid piping apply to the flexible venting.** Flex kits may not be modified. Flex kits may be added to the end of a vent run made of rigid vent sections using pipe manufacturer's approved flex to pipe adapters. This may occur only if doing so does not violate any of the venting length, height, routing, horizontal to vertical ratio requirements or clearance considerations detailed in this manual.

2. The flex adapter starter kit (DVFA/8) is used to attach flex venting to the appliance starting collar. It includes 4" inner and 7" outer adapter rings (refer to *Figure 1*).

- The inner and outer adaptor rings are required to start all flex runs.
- Never install damaged or torn flexible venting.
- Over tightening clamps may rip, tear, or otherwise damage flexible venting.
- The adaptor kit does not include individual pipe sections which may be purchased separately. (UL1777 listed type flex venting only.)

3. Start the flexible vent as follows—

A. Installing the inner flex adaptor and pipe (see *Figure 1*).

1. Insert the long side of the 4" inner ring into exhaust pipe, gently tap to seat into place, and secure with screws.
2. Slide the small gear clamp over the inner flexible vent pipe, and push out of the way.
3. Pull and extend the inner flexible vent.
4. Slide the inner vent onto the adapter collar, for a minimum 1 3/4" overlap.
5. Locate the clamp at approximately 3/4" from the flex end and tighten.
6. Secure the clamped inner section with three self tapping screws, drilled equidistance, just above the clamp perimeter.

B. Installing the outer flex pipe (refer to *Figure 1*).

1. Firmly insert the outer adapter ring into the outer appliance starting collar and secure with screws.
2. Slide the large gear clamp over the outer flexible vent pipe, and push out of the way.
3. Pull and extend the outer flexible vent.
4. Slide the outer vent onto the appliance collar outer adapter for a minimum 1 3/4" overlap.
5. Locate the clamp at approximately 3/4" from the flex end and tighten.
6. Secure the clamped outer section with three self tapping screws, drilled equidistant, just above the clamp perimeter.

C. Routing UL1777 flex pipe.

1. Always maintain the required clearance when routing the flex vent assembly.
2. Install firestop spacers (see *Figure 3*) when penetrating ceilings, attic spaces, or walls.

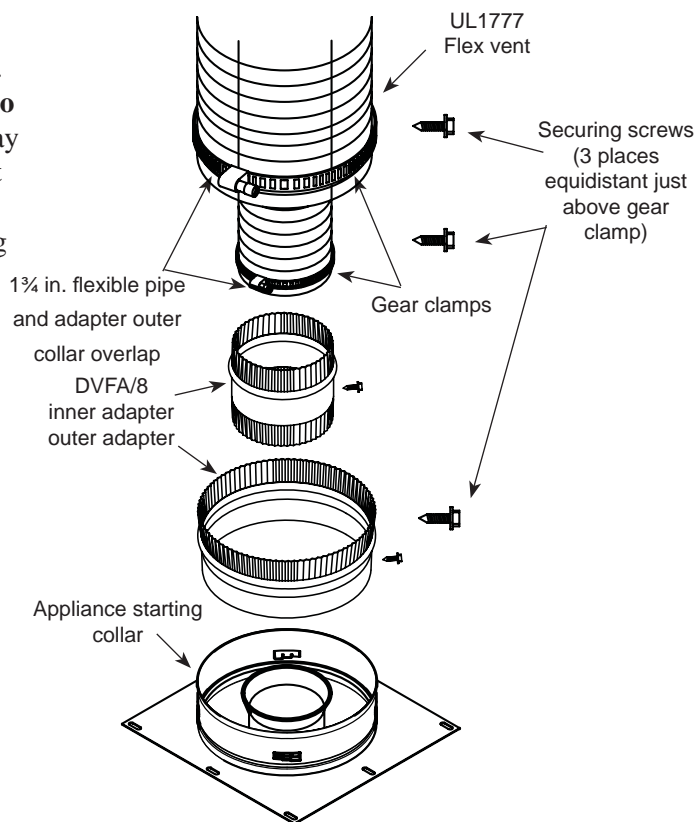

Figure 1 —
Typical appliance connection

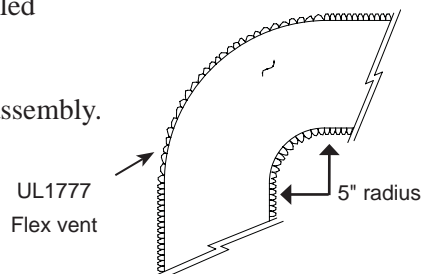

Figure 2 —
Minimum radius for flex vent section

NOTE

Flex vent pipe spacers: Refer to manufacturer's specifications for correct positioning of the spacer springs to maintain proper distance between inside and outside pipe.

FLEX VENT INSTALLATION

3. Do not allow the flexible vent to bend in radius tighter than 5" (127mm). Refer to *Figure 2*.
4. Horizontal runs of flexible vent shall be supported at maximum 2 foot intervals; vertical runs, five feet intervals. Metal strapping, properly secured, is an acceptable means to support the flexible vent.
5. Flexible vent spacers are to be installed at intervals prescribed by the flexible vent manufacture; and in such a way as to maintain concentric inner and outer vent spacing.

D. Attaching flexible venting to vertical termination assemblies.

1. When using Simpson pipe, a MHS flex-to-pipe adaptor and/or rigid pipe section(s) is required to connect the flexible vent assembly to the vertical termination by using three self penetrating screws.
2. Review *Figure 4* and corresponding instructions for proper overlap, clamp and screw placement.
3. Three each self penetrating screws are drilled opposite one another and below the gear clamp.
4. Use only listed and approved terminations and accessories, installed per the installation instructions and *Figure 3*.

E. Installing flexible venting to horizontal termination assemblies.

1. Connect the 4" flexible vent to the horizontal termination as in *Figure 5*.
2. Slide termination cap adapter ring over the termination cap's outside pipe and secure with three screws.
3. Connect the 7" flexible vent to the termination adapter ring as in *Figure 5*.
4. Review *Figure 5* for proper overlap and clamp placement
5. Three each self penetrating screws are drilled opposite one another and below the gear clamp.
6. Use only listed and approved terminations and accessories, installed per the termination instructions and *Figure 5*.

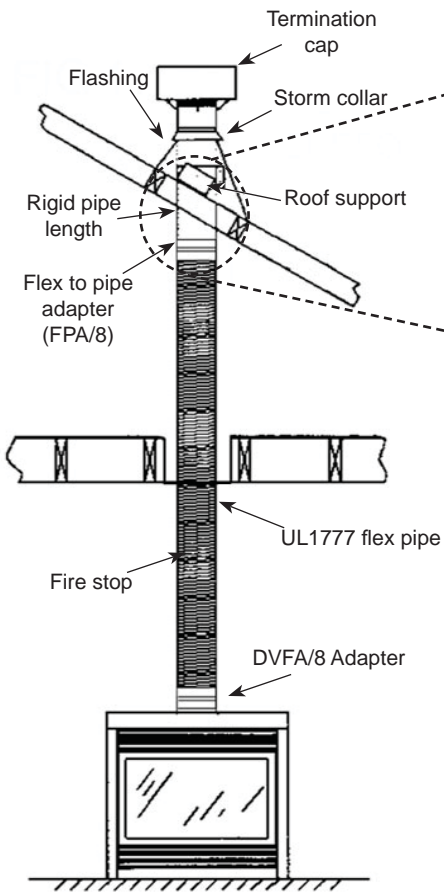

Figure 3 —
Typical vertical flex vent installation

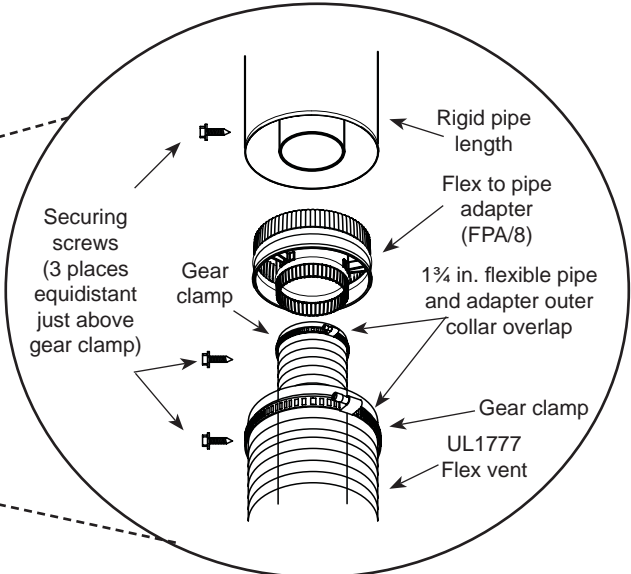

Figure 4 — Typical pipe connection

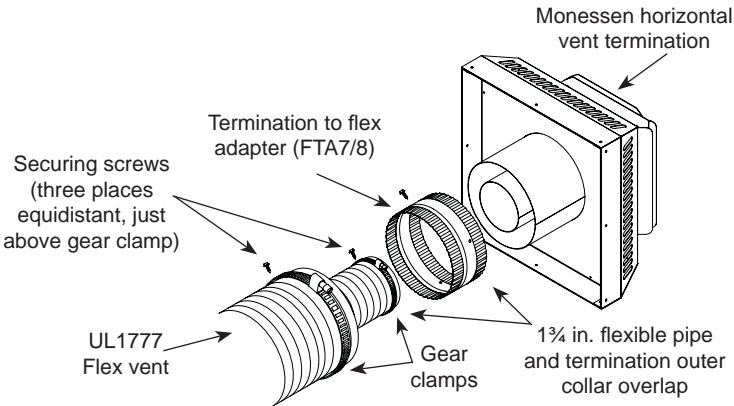

Figure 5 —
Typical horizontal flex vent installation

FIREPLACE INSTALLATION

CHECK GAS TYPE

Use proper gas type for the fireplace you are installing. If you have conflicting gas type, do not install fireplace. See dealer where you purchased the fireplace for proper fireplace for your gas type or conversion kit.

INSTALLING GAS PIPING TO FIREPLACE / BURNER SYSTEM LOCATION

INSTALLATION ITEMS NEEDED

Before installing fireplace and burner system, make sure you have the items listed below.

- External regulator (supplied by installer)
- Piping (check local codes)
- Sealant (resistant to propane/LP gas)
- Equipment shutoff valve*
- Test gauge connection*
- Sediment trap (recommended)
- Tee joint
- Pipe wrench
- approved flexible gas line with gas connector (if allowed by local codes — not provided)

* A CSA design-certified equipment shutoff valve with $\frac{1}{8}$ " NPT tap is an acceptable alternative to test gauge connection. Purchase the CSA design-certified equipment shutoff valve from your dealer.

For propane/LP connections only, the installer must supply an external regulator. The external regulator will reduce incoming gas pressure. You must reduce incoming gas pressure to between 11 and 13 inches of water. If you do not reduce incoming gas pressure, burner system regulator damage could occur. Install external regulator with the vent pointing down as shown in *Figure 39*. Pointing the vent down protects it from freezing rain or sleet.

WARNING

A qualified installer or service person must connect appliance to gas supply. Follow all local codes.

CAUTION

For propane/LP units, never connect fireplace directly to the propane/LP supply. This burner system requires an external regulator (not supplied). Install the external regulator between the burner system and propane/LP supply.

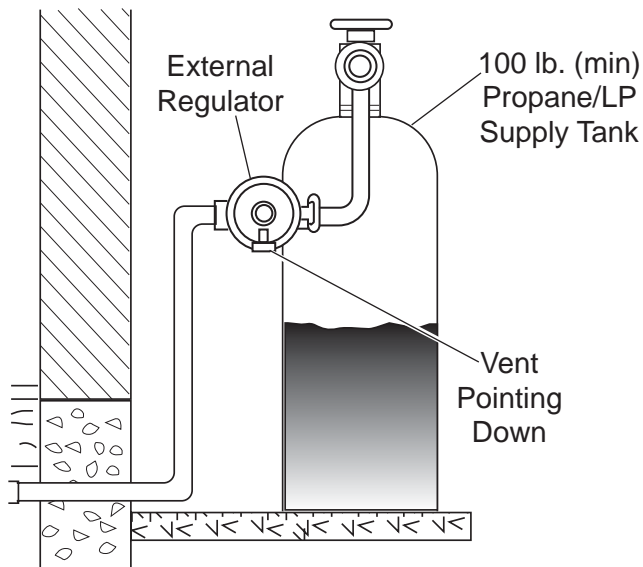

Figure 39 - External Regulator with Vent Pointing Down (Propane/LP Only)

CAUTION

Use only new black iron or steel pipe. Internally tinned copper or copper tubing can be used per National Fuel Code, section 2.6.3, providing gas meets hydrogen sulfide limits, and where permitted by local codes. Gas piping system must be sized to provide minimum inlet pressure (listed on data plate) at the maximum flow rate (BTU/hr). Undue pressure loss will occur if the pipe is too small.

When using copper or flex connectors use only fittings approved for gas connections. The gas control inlet is $\frac{3}{8}$ " NPT.

WARNING

Only persons licensed to work with gas piping may make the necessary gas connections to this appliance.

CAUTION

A manual shutoff valve must be installed upstream of the appliance. Union tee and plugged $\frac{1}{8}$ " NPT pressure tapping point should be installed upstream of the appliance. See *Figure 40*.

NOTE : The gas line connection may be made using $\frac{1}{2}$ " rigid tubing or an approved flex connector. Since some municipalities have additional local codes it is always best to consult your local authorities and the current edition of the National Fuel Gas Code ANSI.Z223.1, NFPA54. In Canada CAN/CGA-B149 (1 or 2) Installation Code.

A listed manual shutoff valve must be installed upstream of the appliance. Union tee and plugged $\frac{1}{8}$ " NPT pressure tapping point should be installed upstream of the appliance. See *Figure 39*.

IMPORTANT: Install main gas valve (equipment shutoff valve) in an accessible location. The main gas valve is for turning on or shutting off the gas to the fireplace.

Check your building codes for any special requirements for locating equipment shutoff valve to fireplaces.

Apply pipe joint sealant lightly to male threads. This will prevent excess sealant from going into pipe. Excess sealant in pipe could result in clogged burner system valves.

We recommend that you install a sediment trap/drip leg in supply line as shown in *Figure 40*. Locate sediment trap/drip leg where it is within reach for cleaning. Install in piping system between fuel supply and burner system. Locate sediment trap/drip leg where trapped matter is not likely to freeze. A sediment trap collects moisture and contaminants and keeps them from going into the burner system gas controls. If sediment trap/drip leg is not installed or is installed wrong, burner system may not run properly.

CAUTION

Use pipe joint sealant that is resistant to liquid petroleum (LP) gas.

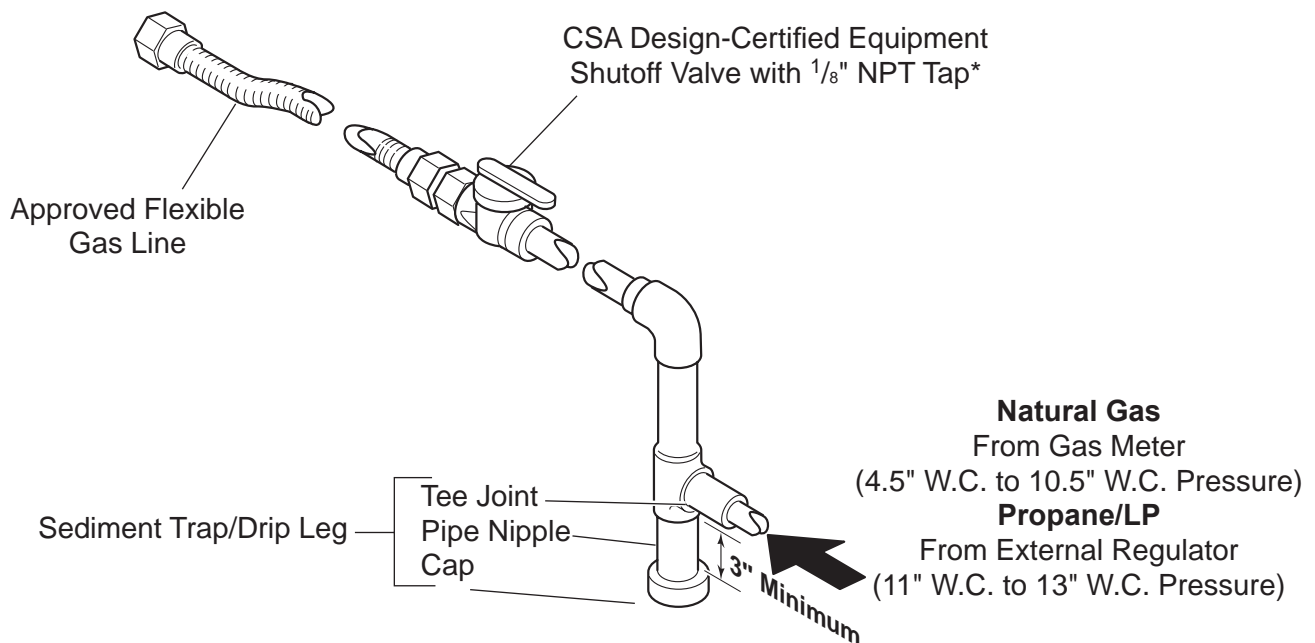

Figure 40 - Gas Connection

CHECKING GAS PRESSURE AND ELECTRICAL INSTALLATION

1. Check gas type. The gas supply must be the same as stated on the appliance's rating decal. If the gas supply is different from the fireplace, STOP! Do not install the appliance. Contact your dealer immediately.
2. To ease installation, a 30" (mm) flex line with manual shut-off valve has been provided with on this appliance. Install and attach 1/2" gas line onto shut-off valve.
3. After completing gas line connection, purge air from gas line and test all gas joints from the gas meter to the fireplace for leaks. Use a solution of 50/40 water and soap or a gas sniffer.
4. To adjust flame height, turn HI/LO knob to HI to get maximum pressure to burner. Turn HI/LO knob to LO to get minimum pressure.
5. To check gas pressures at valve, turn captured screw counter clockwise 2 or 3 turns and then place tubing to pressure gauge over test point. Turn unit to high. *See Figure 41.* After taking pressure reading, be sure and turn captured screw clockwise firmly to reseal. Do not over torque. Check test points for gas leaks.

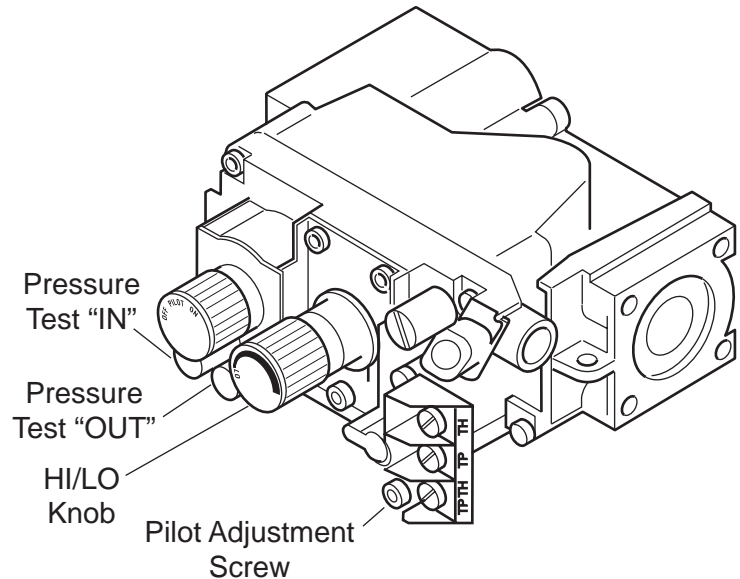

Figure 41 - Gas Pressure Check at Gas Valve

WARNING

Do not use open flame to check for gas leaks.

ELECTRICAL WIRING

This fireplace will work without any electrical supply except to operate blower and electronic ignition system.

NOTE: *If installed in mobile home, fireplace must be bolted securely to floor.*

WARNING

Electrical connections should only be performed by a qualified, licensed electrician. Main power must be off when connecting to main electrical power supply or performing service. All wiring shall be in compliance with all local, city, and state codes. The appliance, when installed, must be electrically grounded in accordance with local codes, or in the absence of local codes, with the *National Electrical Code ANSI/ NFPA 70 (latest edition) and Canadian Electrical Code, CSA C22.1.*

CAUTION

Label all wires before disconnecting when servicing controls. Wiring errors can cause improper and dangerous operation.

Verify proper operation after servicing.

REMOTE WALL MOUNTED SWITCH

A remote wall switch and up to fifteen (15) feet of 18 gauge wire may be used with this appliance. Attach the wall switch in a junction box at the desired location on the wall. See Figure 42. Do not extend beyond the wall switch wire length provided.

WARNING

Do not connect 110V to wall switch.

NOTE: Extended lengths of wire may cause the fireplace not to function properly. Longer length of wire is permitted if the wire is made out of larger gauge (diameter) wire. Always check with local code.

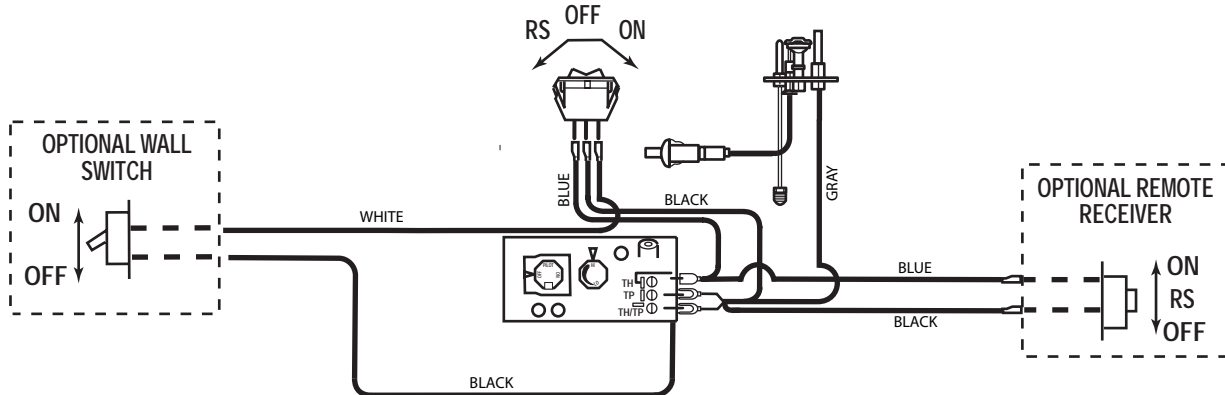

Figure 42 - Wiring Diagram for Wall Switch

REMOTE WALL SWITCH

Position the wall switch. Do not extend beyond the 15 feet of wire.

OPTIONAL DC REMOTE SYSTEMS

These instructions replace the section entitled *Hearth Mount* in the Millivolt hand held remote instructions supplied with the remote.

1. Plug in remote connector wire to remote receiver.
2. Connect the wire terminal from the remote receiver. This replaces the 15' wall switch connection to the switch. See Figure 42.
3. Mount remote control receiver at junction box (for your wall switch).

OPTIONAL FAN/BLOWER SYSTEMS

The junction box for the fan/blower systems has been factory installed. This system requires that 110-120 VAC to be wired to the factory installed junction box before the fireplace is permanently installed. See Figure 43.

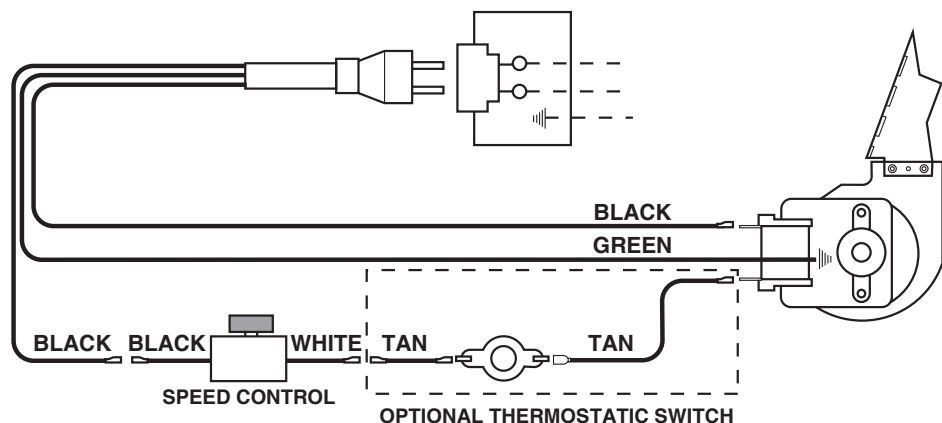

Figure 43 - Blower Wiring Diagram

GLASS REMOVAL & BRICK INSTALLATION

GLASS FRAME REMOVAL

1. Release two clamps on bottom of fireplace. *See Figure 44.*
2. Tilt glass frame out and lift glass frame up until it clears three tabs on top of fireplace.
3. Set glass frame aside.

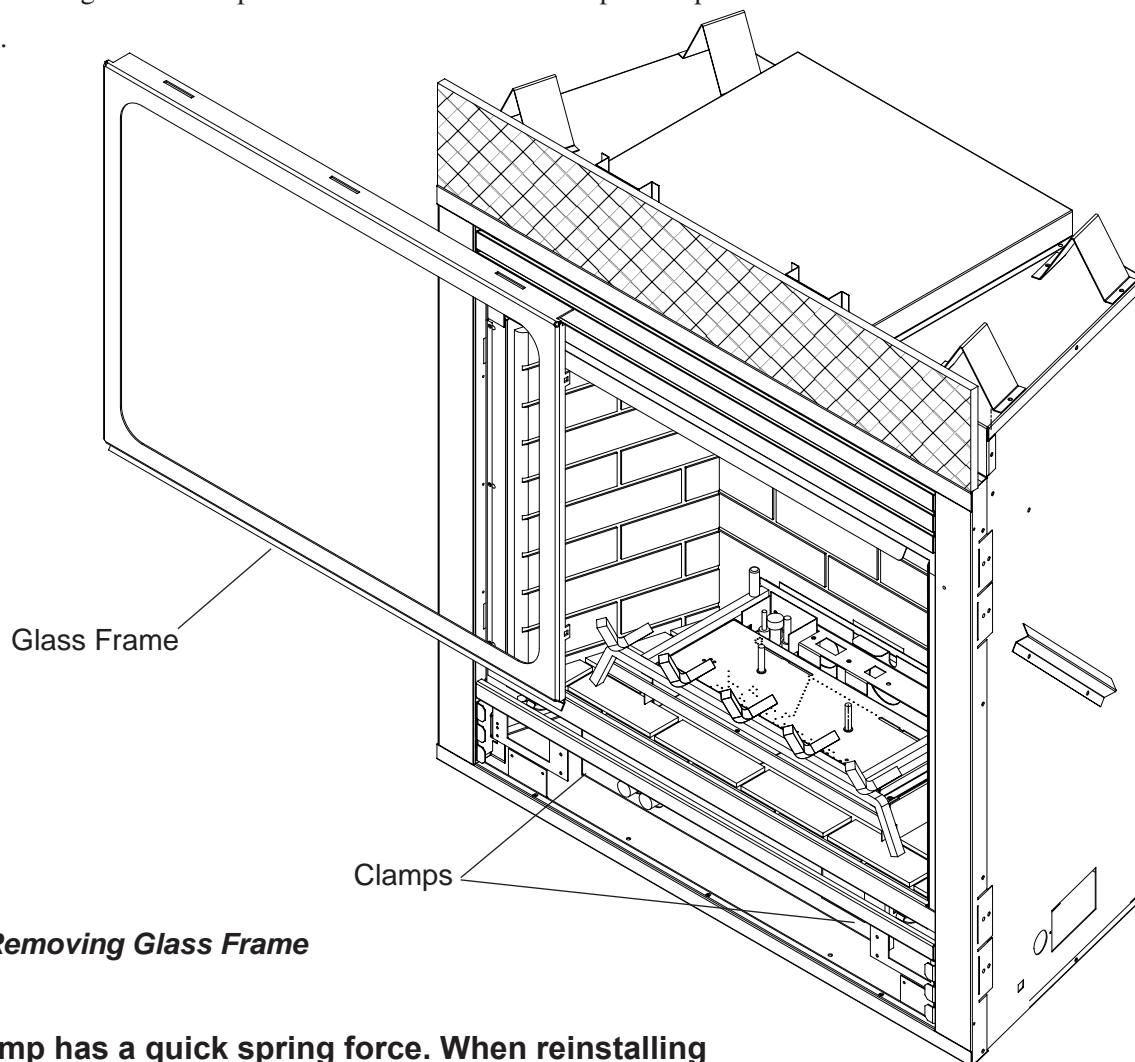

Figure 44 - Removing Glass Frame

CAUTION: Each clamp has a quick spring force. When reinstalling clamps, keep fingers clear.

BRICK INSTALLATION

1. Remove glass door frame and log set.
2. Remove the glass heat shield, baffle and rear bracket.
3. Install the center firebrick panel on the back wall first. Stand firebrick panel straight up against the back of fireplace with the bottom edge at bottom of inner firebox.
4. Repeat Step 3 with the left and right side firebrick panels. Secure the top of each side firebrick panel to the fireplace with one retainer bracket and one screw.
5. Use a screw gun to drive in the self-drilling screw into the sheet metal through the hole in the retainer bracket.
6. Re-install glass heat shield, baffle and rear bracket.
7. Re-install glass door frame and log set.

PLACEMENT OF LAVA ROCK, ROCK WOOL AND LOGS

1. Make sure that the grate is hooked onto the rear bracket.
2. Sprinkle the lava rocks around and in front of the burner at bottom of firebox.
3. Place rock wool in a dime size pieces over the small holes and partially over large size holes. Do not place any over slots at rear of burner. The rock wool over the large holes may need adjustment after firing the unit to establish yellow flame in the front. *See Figure 46.*
4. Place log #1 into place by setting the log over the two pins on the grate toward the back. The two round holes on the bottom of the logs should go over the two pins on the grate. *See Figure 47.*
5. Place log #2 into place by matching the two holes on the bottom of the log with the two pins located on top of the burner. When this log is in place it is positioned at an angle and the right side of the log is seated over the right tong of the grate. *See Figure 48.*

WARNING

Do not use the entire bag of rock wool to cover the burner. This could cause the flame to burn poorly and may lead to sooting.

WARNING

Do not sprinkle the lava rock or ember chunks on top of the burner. This may cause potential sooting, glass breakage and a fire hazard.

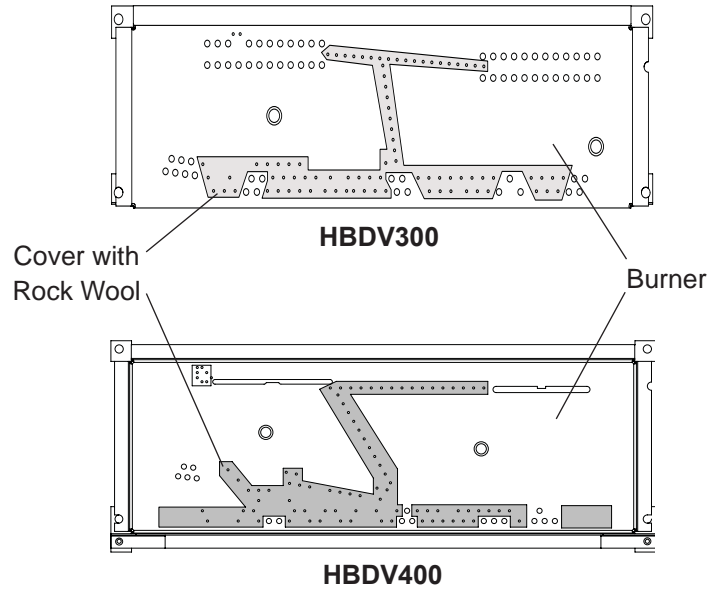

Figure 45 a & b - Placement of Rock Wool on Burners



Figure 46 - Placement of Rock Wool on Burner

Log #1



Figure 47 - Placement of Log 1.

FINAL INSTALLATION



Figure 48 - Placement of Log 2



Figure 49 - Placement of Log 3

- 6a. For 400 models, place log #3 into place by matching the notch on the side of the log with the protrusion on the rear log. Set the left side of the log over the cross bar of grate by placing the notch of the log on the grate bar. Be sure the log is tilted backward. When this log is in place, it is seated sideways. *See Figure 49.*
- 6b. For 300 models, place log #3 into place by matching the notch on the side of the log with the protrusion on the rear log. Set the left side of the log over the grate bar in the front by placing the notch of the log on the grate bar. Make sure the log is tilted backward. When this log is in place, it is seated sideways. *See Figure 49.*



Figure 50 - Placement of Log 4



Figure 51 - Placement of Log 5

7. Place log #4 into place by matching the two notches on the bottom of this log with the two protrusions on log #1&2. This log, when seated, fits in the middle above logs 1 & 2. *See Figure 50.*
8. Place log #5 into place by matching the two notches on the bottom of this log with the two protrusions on log #1&2. This log, when seated, is positioned toward the right. *See Figure 51.*
- 9a. For 400 models, place log #6 into place toward the left by sitting the notch on this log on the left tong of the grate and set the tips of the log on the burner in front the large round holes. *See Figure 52.*
- 9b. For 300 models, place log #6 into place toward the left by sitting the notch on this log on the left tong of the grate and set the tips of the log on the burner. *See Figure 52.*
10. For 400 models only, place log #7 into place by hooking the end of the log on the second right tong of the grate and resting the other end over the lava rock. *See Figure 53. (There is no seventh log on 300 models.)*
11. Adjust the screws and set the andirons over the cross bar of the grate between the two outer tongs on the right and left sides of the grate.



Figure 52 - Placement of Log 6



Figure 53 - Placement of Log 7 (HBDV400 only).



Figure 54 a & b - Andiron Placement (400DVBH and 300DVBH).

INSTALLING UNIVERSAL ANDIRONS

Bolt bracket through lower slot into top andiron hole. Slide clip over horizontal fireplace grate bar. See Figure 55.

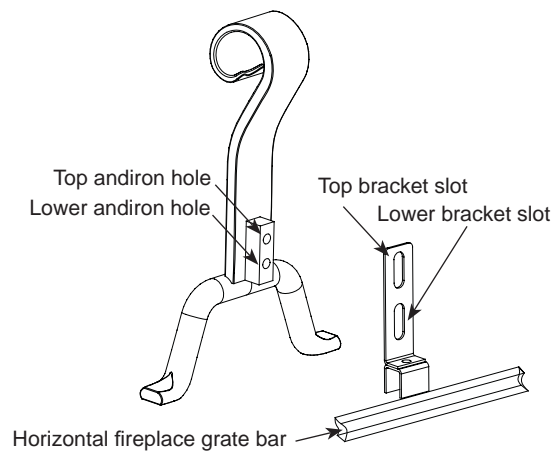

Figure 55 - Universal Andirons

FOR YOUR SAFETY READ BEFORE LIGHTING

WARNING

If you do not follow these instructions exactly, a fire or explosion may result causing property damage, personal injury or loss of life.

- A. This appliance is equipped with a pilot which must be lit with built-in piezo ignitor while following these instructions exactly.
- B. BEFORE OPERATING smell all around the appliance area for gas. Be sure to smell next to the floor because some gas is heavier than air and will settle on the floor.

WHAT TO DO IF YOU SMELL GAS:

- Turn off all gas to the appliance.
 - Open windows.
 - Do not attempt to light any appliance.
 - Do not touch any electric switch; do not use any phone in your building.
 - Immediately call your gas supplier from a neighbor's phone. Follow the gas supplier's instructions.
 - If you cannot reach your gas supplier, call the fire department.
- C. Use only your hand to push in, or turn the gas control knob. Never use tools. If the knob will not push in or turn by hand, don't try to repair it. Call a qualified service technician. Force or attempted repair may result in a fire or explosion.
 - D. Do not use this appliance if any part of it has been under water. Immediately call a qualified service technician to inspect the appliance and to replace any part of the control system and any gas control that has been under water.

LIGHTING PILOT FOR THE FIRST TIME

INITIAL LIGHTING

Purge air from the supply line as follows:

- Open main shutoff valve.
- Unscrew main pressure test point.
- Leave inlet test screw open until gas comes in.
- When gas is flowing, tighten inlet screw immediately.

WARNING

Never use an open flame to check for gas leak.

LEAK TESTING

1. Follow the pipe from the gas supply line connection to the gas valve. Check connection for leaks with soap and water mixture.
2. Next check for gas leaks at the burner with soap and water mixture.
3. Check the pilot for gas leaks with soap and water mixture.

LIGHTING PILOT FOR THE FIRST TIME

APPROVED LEAK TESTING METHOD

You may check for gas leaks with the following methods only:

- Soap and water solution
- An approved leak testing spray
- Electronic sniffer

DANGER

Never check for gas leak with open flame!

WARNING

If using a soap and water solution to test for leaks, DO NOT spray solution onto control body.

NOTE: Remove any excessive pipe compound from the connections. Excessive pipe compound can set off electronic sniffers.

Check for gas leaks in each of the following locations:

- Pipe from the gas supply line connection to the gas valve
- Burner connections
- Pilot
- Each joint or connection
- Field made joints / gas shutoff valve
- Factory made joints
- All joints on valve and control body

LIGHTING PILOT

WARNING

The control has an interlock device that does not allow the lighting of the fireplace up to the moment the safety device of the flame has not interrupted the gas flow. After that period of time (when the magnet is closed), it is possible to start the lighting operation.

The gas control knob is designed to be operated by hand. **DO NOT** use any tools during this operation. Damaged knobs may result in serious injury.

1. Depress and turn knob counterclockwise  to pilot position.
2. Depress fully and hold pilot gas knob. Depress piezo igniter as many times as needed to ignite pilot. Keep knob fully depressed for a few seconds. Release and check that pilot continues to burn.

If the pilot does not stay lit, repeat steps 1 and 2.

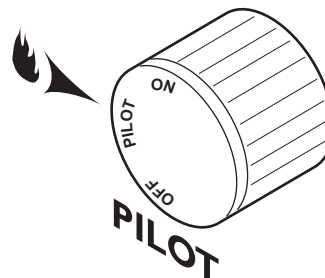

Figure 56 - Pilot Position

Continued on next page

LIGHTING BURNER

MAIN BURNER SWITCH

The “ON/OFF/RS” switch for the main burner can be found behind door of the fireplace. This switch allows you to turn on and to turn off the main burner without using the gas valve knob. Make sure the button is in the “ON” position to light the main burner. *See Figure 57.*

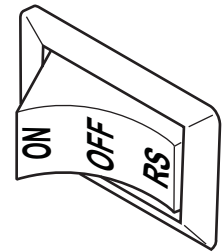



Figure 57 - On/Off/RS Switch

LIGHTING THE BURNER

Depress and turn the knob counterclockwise  to the “ON” position. *See Figure 58.* It will take less than four (4) seconds for the burner to ignite.

PILOT POSITION

Depress and turn knob to pilot position to keep burner off while maintaining the pilot light. *See Figure 59.*

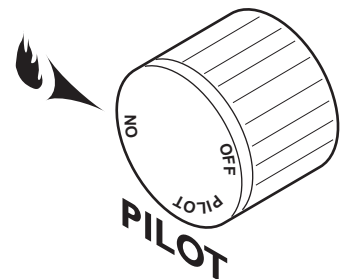

Figure 58 - On Position

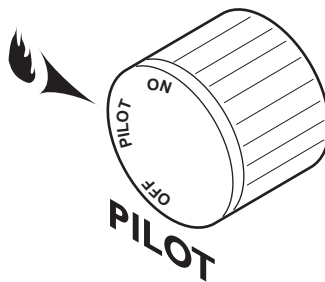

Figure 59 - Pilot Position

TO TURN OFF GAS

Depress and turn knob clockwise  to “OFF” position. *See Figure 60.*

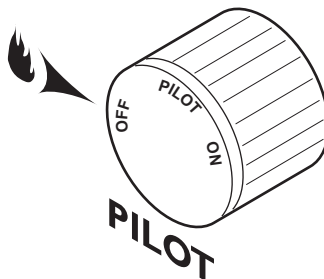

Figure 60 - Off Position

WARNING

Turn off gas before servicing fireplace. It is recommended that a qualified service technician perform these check-ups at the beginning of each heating season

BURNER, PILOT AND CONTROL COMPARTMENT

Keep the control compartment, logs, and burner areas surrounding the logs clean by vacuuming or brushing at least twice a year. Make sure the burner porting, pilot air opening and burner air opening are free of obstructions at all times.

PILOT FLAME

The flames from the pilot should be visually checked as soon as the heater is installed and periodically during normal operation. **The pilot flame must always be present when the fireplace is in operation.** See *Figure 61*. The pilot flame has three distinct flames, one engulfing the thermopile, one engulfing the thermocouple, and the other reaching to the main burner.

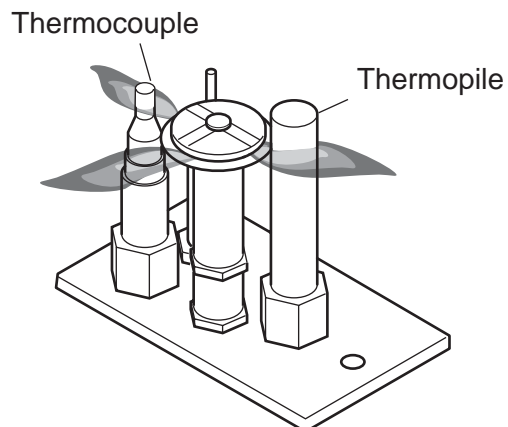

Figure 61 - Pilot Flame

BURNER

Inspect area around the injector. Remove any lint or foreign material with a brush or vacuum.

BURNER FLAME

The flames from the burner should be visually checked as soon as the heater is installed and periodically during normal operation. In normal operation, at full rate, and after operating for about 15 to 30 minutes, the flame should be yellow and slightly taller than the rear log. See *Figure 62*.

If the flame is blue and only in the center, turn off unit and let cool. After unit is cool, remove logs and check to make sure the back holes in the burner are not covered with rock wool. If the back holes are clear, add more rock wool to the center of the burner. Replace logs.

NOTE: The type of installation, vent system configuration, and wind effects may cause the flame patterns to vary.

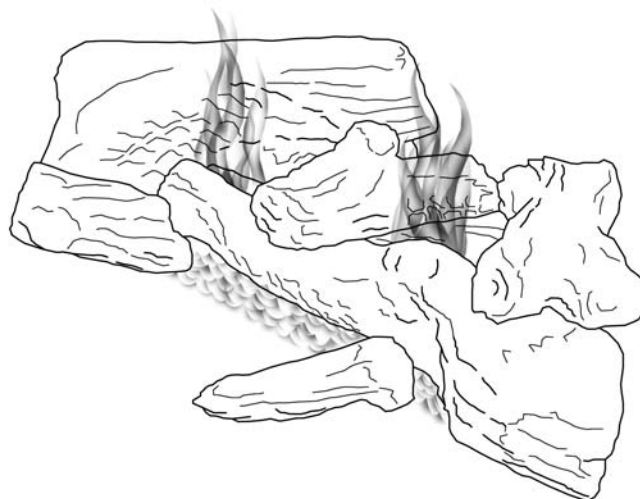

Figure 62 - Burner Flame Appearance

CLEANING AND MAINTENANCE

VENT SYSTEM

The fireplace and venting system should be inspected before initial use and at least annually by a qualified field service person. Inspect the external vent cap on a regular basis to make sure that no debris is interfering with the airflow. Inspect entire venting system to ensure proper function.

GLASS DOOR

Thoroughly clean the inside of the glass door after using the fireplace for ten hours. Periodically clean the glass door as necessary.

When cleaning the glass, remember:

- **Do not remove the glass when hot.** Allow glass to cool before removal.
- NEVER use abrasive materials.
- Keep children and pets a safe distance away.
- Never operate the fireplace without the glass door properly secured.
- Never operate the fireplace if the glass is broken.
- Replace any glass that is chipped, cracked, or broken. Replacement glass door assemblies **MUST** be supplied by the fireplace manufacturer – **No substitute materials may be used.**
- Handle glass door with care to avoid striking or scratching it on hard objects.

To clean glass door, follow “Glass Removal” procedure outlined in the *Final Installation* section. Film deposit on the inside of the glass should be cleaned off using a nontoxic, non-corrosive, non-abrasive, mild-cleaning solution. Simply apply an adequate amount to the glass and wipe off with a damp cloth. After all maintenance has been completed, re-install glass door.

LOGS

Leave logs installed in the fireplace for cleaning. Vacuum surface of the logs with a brush attachment. If logs must be removed for cleaning, handle carefully by holding gently at each end. Gloves are recommended to prevent skin irritation from ceramic fibers. If skin becomes irritated, wash gently with soap and water. Vacuum surface of logs with brush attachment or brush logs with a soft bristle brush (i.e. clean, dry paintbrush). To place logs back in the fireplace, see “Log Placement” found in the *Final Installation* section.

NOTE: Do not use fluids to clean ceramic fiber logs.

ROCK WOOL

Replace or add rock wool as required following installation instructions in the *Final Installation* section of this manual.

STANDING PILOT IGNITION

SYMPTOM	POSSIBLE CAUSE	ACTION
1. Spark ignitor will not light pilot after repeated triggering of piezo.	<ul style="list-style-type: none"> A. Wire disconnected. B. Defective ignitor. C. No gas or low gas pressure. D. No Propane/LPG in tank 	<ul style="list-style-type: none"> A. Open door and check to make sure wire is connected to ignitor. B. Check for spark at electrode and pilot. If no spark and electrode wire is properly connected, replace pilot assembly. C. Check remote/manual shut off valve from fireplace. Low pressure can be caused by bent lines, restricted lines, low pressure line pressure. Consult with plumber or gas supplier. D. Check Propane/LPG tank. Refill tank.
2. Pilot will not stay lit after carefully following lighting instructions.	<ul style="list-style-type: none"> A. Defective thermocouple B. Defective valve 	<ul style="list-style-type: none"> A. Check that thermocouple flame impinges on thermocouple. Clean and/or adjust pilot for maximum flame impingement. Ensure that the thermocouple connection at the gas valve is fully inserted and tight. Disconnect the thermocouple from the valve, place one millivolt lead wire on the tip of the thermocouple and the other meter lead wire on the thermocouple copper lead. Start the pilot and hold the valve knob in. If the millivolt reading is less than 15 mV, replace pilot assembly. B. If thermocouple is producing more than 15 mV, replace faulty valve.
Pilot burning, valve knob turned to "ON", switch is turned to "ON" or "RS", but burner will not ignite.	<ul style="list-style-type: none"> A. Defective switch, wall switch, remote control or wire B. Pilot flame too small C. Defective or malfunctioning thermopile D. Defective valve 	<ul style="list-style-type: none"> A. Check switch and wire for proper connection. Place jumper wires across terminals of switch. If burner comes on, replace defective switch. If the switch is OK, repeat the same procedure on remote control. If burner comes on, replace remote control. Place jumper wire across wire at gas valves (terminals marked TH and TP/TH). If burner comes on, wires are faulty or connections are bad. Replace wire. B. If pilot flame is not close enough to the thermopile, adjust pilot flame. C. Check thermopile wire connections to make sure all are tight and that the thermopile is fully inserted into pilot assembly. Check thermopile with a millivolt meter. Connect leads to TP and TP/TH terminals on the control valve. If meter reading is below 325 mV, replace pilot assembly. D. Turn valve knob to "On" and switch to "ON." Take a reading at the thermopile leads (TP & TP/TH) on the valve. If the meter reads greater than 175 mV and the burner does not light, replace defective valve.

TROUBLESHOOTING

STANDING PILOT IGNITION

SYMPTOM	POSSIBLE CAUSE	ACTION
4. Frequent pilot outage problem.	A. Pilot flame may be too high or too low, causing pilot safety to drop out	A. Clean and adjust the pilot flame for maximum flame impingement on thermocouple.
5. The pilot and main burner extinguish while in operation	A. Inner vent pipe leaking exhaust gases back into system B. Horizontal vent improperly pitched C. Improper vent cap installation	A. Check for flue product leak. Replace defective pipe section. B. Check horizontal-venting piping is running upward 1/4" per foot. Do not run the pipe level or downward. C. Check for proper installation and freedom from debris or blockage.
6. Glass Soots	A. Flame impingement on logs	A. Install log set per the instructions Inspect the injector and air intake area. Make sure this area does not have any blockage from debris and clean. Check gas supply.
7. Flame burn blue and lifts off burner (ghosting)	A. Insufficient oxygen being supplied	A. Ensure that the vent cap is installed properly and free of debris. Ensure that the vent system joints are tight and have no leaks. Ensure that no debris has been blocking the inner air intake at the bottom back of the combustion chamber. Ensure that the glass is properly secure and latch.

FIREPLACE COMPONENTS

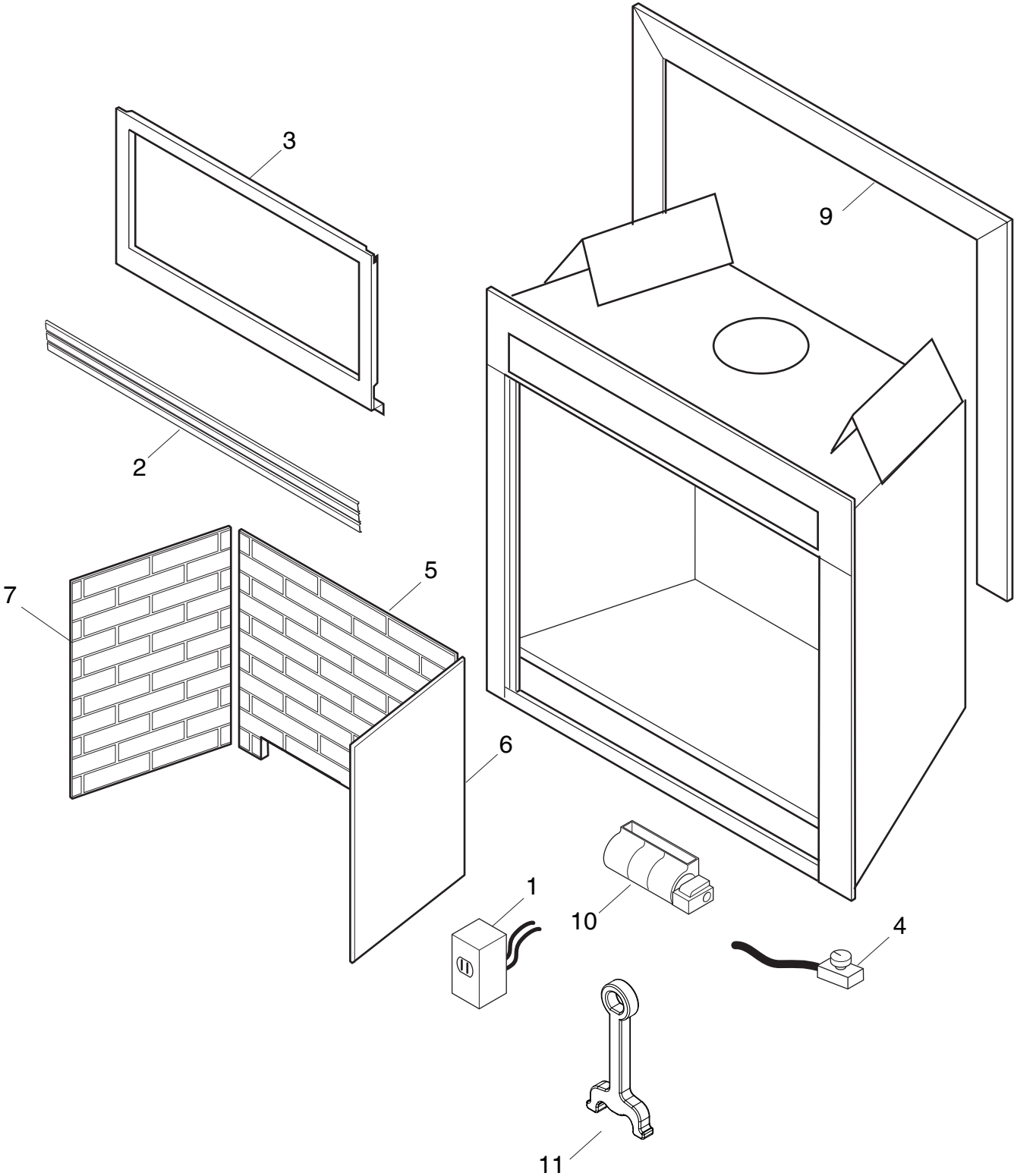

REPLACEMENT PARTS

FIREPLACE COMPONENTS

Item	Description	Qty	HBDV300	HBDV400
Standard Features				
1	Junction Box Assembly	1	26D2128K	26D2128K
2	Black Louver (each)	1	54D0246	26D0695
3	Glass Frame Assembly	1	54D5113	54D5034
11	Andiron Kit (contains 2)	1	UA19	UA19
Accessories/Field Installed Options				
2	Brass Louver Assembly (upper and lower)	1	L30BR	L32BR
2	Pewter Louver Assembly (upper and lower)	1	L30PW	L32PW
4	Thermostat Sensor	1	26D2870	26D2870
5	Standard Firebrick Center CC	1	26D7069	26D7077
6	Standard Firebrick Right CC	1	26D7068	26D7076
7	Standard Firebrick Left CC	1	26D7068	26D7075
5	Standard Firebrick Center CR	1	26D7097	26D7105
6	Standard Firebrick Right CR	1	26D7096	26D7104
7	Standard Firebrick Left CR	1	26D7096	26D7103
8	Cottage Clay Firebrick Walls	1	FB300CCW	FB400CCW
8	Cottage Red Firebrick Walls	1	FB300CRW	FB400CRW
9	Brass Curved Design Trim	1	BRTK30C	BRTK32C
9	Pewter Curved Design Trim	1	PWTK30C	PWTK32C
9	Black Curved Design Trim	1	BLTK30C	BLTK32C
9	Black Trim	1	BLMTK30	BLMTK32
9	Pewter Trim	1	PWMTK30	PWMTK32
9	Brass Trim	1	BRMTK30	BRMTK32
10	Blower Motor	1	26D0748	26D0748
N/S	T-stat Blower with Speed Control	1	BLOT	BLOT

CC=Cottage Clay

CR=Cottage Red

MILLIVOLT ENGINE

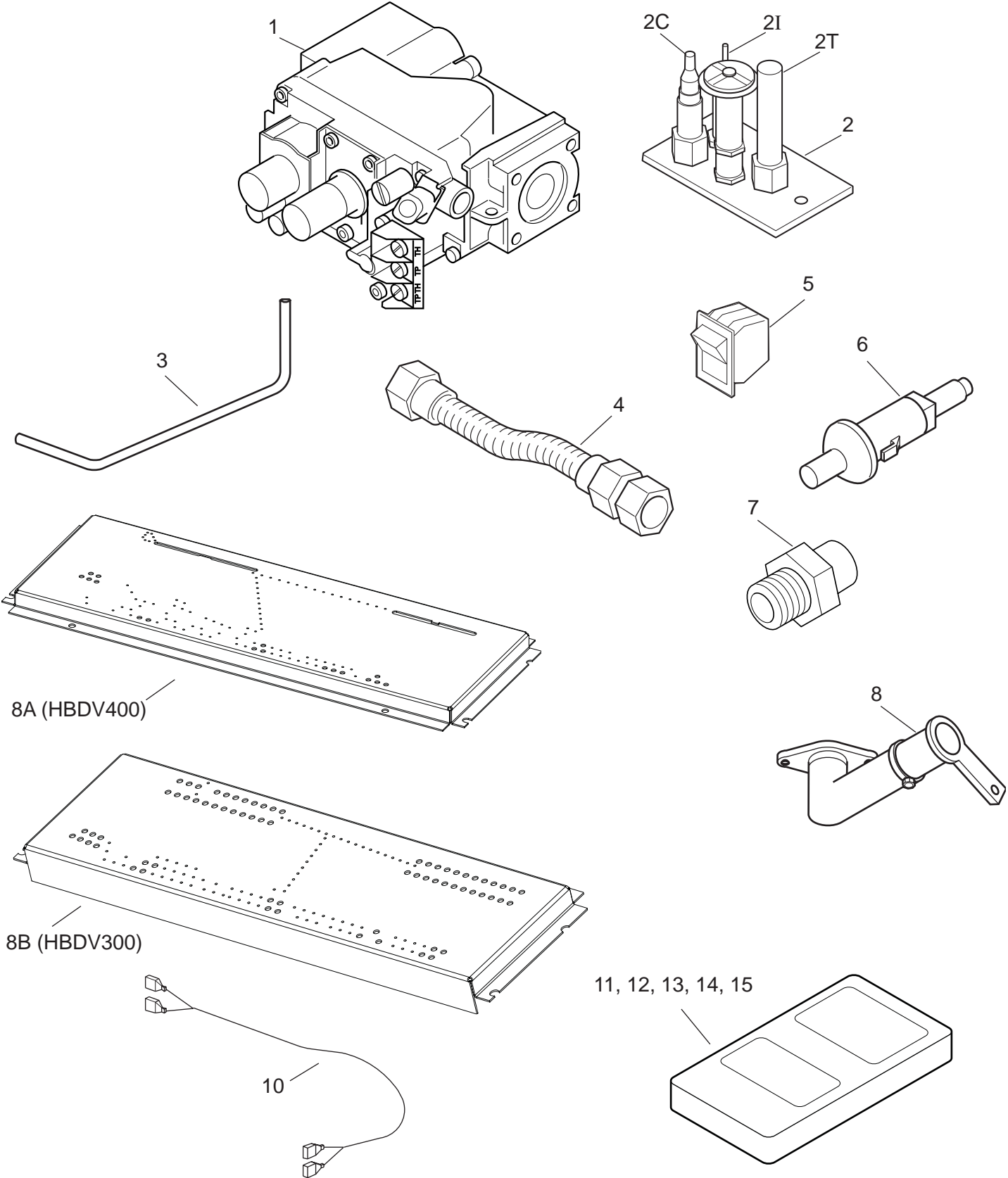

REPLACEMENT PARTS

MILLIVOLT COMPONENTS

ITEM	DESCRIPTION	QTy	HBDV300NV	HBDV300PV	HBDV400NV	HBDV400PV
1	Gas Valve Assembly	1	37D0117	37D0118	37D0117	37D0118
2	Pilot Assembly	1	37D0018	37D0019	37D0018	37D0019
2C	Replacement Thermocouple	1	37D1067	37D1067	37D1067	37D1067
2I	Replacement Igniter and Wire	1	37D1069	37D1069	37D1069	37D1069
2T	Replacement Thermopile	1	37D1068	37D1068	37D1068	37D1068
3	Burner Tube	1	54D0288	54D0288	54D0194	54D0194
4	Flexhose with Shutoff Valve	1	23D6046	23D6046	23D6046	23D6046
5	Rocker Switch	1	41D0048	41D0048	41D0048	41D0048
6	Piezo Igniter	1	14D0503	14D0503	14D0503	14D0503
7	Injector	1	62D3006	20H3156	62D3004	33D5039
8	Burner Assembly	1	54D5115	54D5115	54D5006	54D5006
9	Venturi	1	45D0600	45D0600	45D0600	45D0600
10	Wire Assembly	1	44D0500	44D0500	44D0500	44D0500
10	Wire Assembly	1	44D0501	44D0501	44D0501	44D0501

ACCESSORIES

11	Thermostatic Remote Control	1	RCT/RCST/ WWTD/RCSTE	RCT/RCST/ WWTD/RCSTE	RCT/RCST/ WWTD/RCSTE	RCT/RCST/ WWTD/RCSTE
12	Remote Control On/Off	1	RCB/RCMT/ RCBE/WMTD	RCB/RCMT/ RCBE/WMTD	RCB/RCMT/ RCBE/WMTD	RCB/RCMT/ RCBE/WMTD
13	Full Function Remote Control	1	RCSTEB/ RCSITE	RCSTEB/ RCSITE	RCSTEB/ RCSITE	RCSTEB/ RCSITE
14	Wall Switch Kit	1	MVWS	MVWS	MVWS	MVWS
15	Wall Thermostat Kit	1	WT	WT	WT	WT

CONVERSION KIT (NOT SHOWN)

	300 Conversion NG to LPG	1	HB300CKP	—	—	—
	300 Conversion LPG to NG	1	—	HB300CKN	—	—
	400 Conversion NG to LPG	1	—	—	HB400CKP	—
	400 Conversion LPG to NG	1	—	—	—	HB400CKN

VENT COMPONENTS

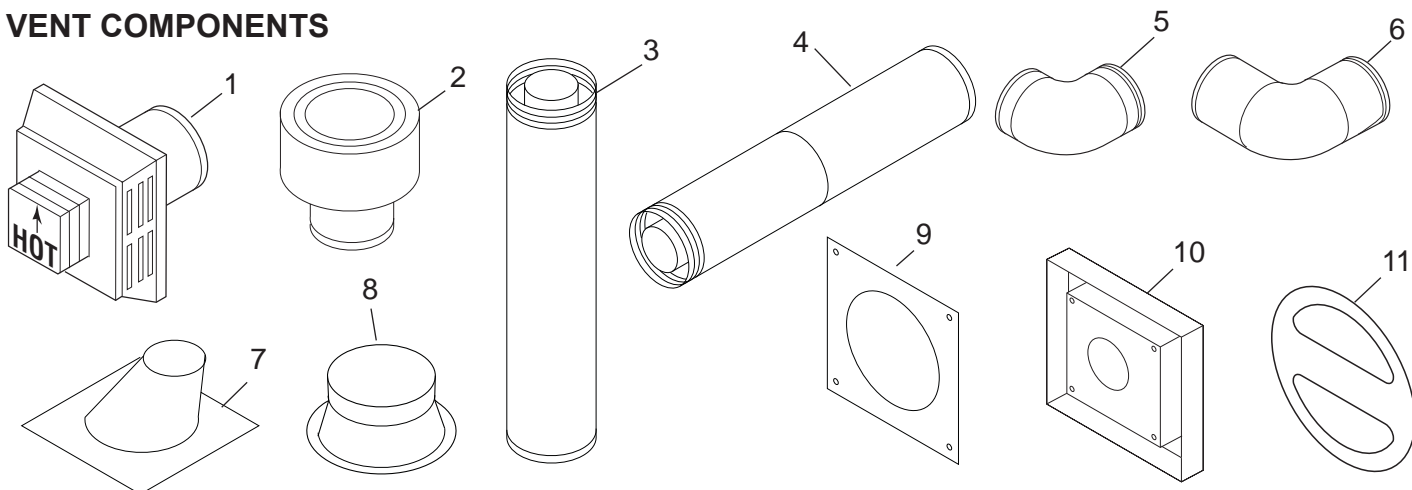

VENT COMPONENTS CONTINUED

Refer to illustrations on previous page.

ITEM	QTY/ BOX	DESCRIPTION	CURRENT SIMPSON DURAVENT OR MHS PART NO.	PREVIOUS SIMPSON DURAVENT OR MHS PART NO.	SELKIRK PART NO.
1	1	Rear Vent Termination Kit includes Termination Cap with built in vinyl siding standoff, heat deflector, firestop and adj 11" to 14 5/8" pipe.	BHRTK9	BHRTK9	—
1	1	Side Wall Termination Kit. Includes termination cap with built in vinyl siding standoff, heat deflector, firestops, adj 11" to 14 5/8" pipe, and 90° elbow.	BHSTK	BHSTK	—
1	1	Side Wall Flexible Pipe Termination Kit. Includes termination cap with built-in vinyl siding standoff, heat deflector, firestop, 20" to 48" flexible pipe and adapter.	BHSFTKA	BHSFTK	—
		Thru-Roof Flexible Pipe Termination Kit w/flex adapter 24" rigid pipe and roof support 4" x 6 5/8"	TRFK	—	—
2	1	Low-Profile Vertical Termination Cap	46DVA-VC	980	4DT-VC
1	1	Square Horizontal Termination Cap (aluminum)	46DVA-HC	985	4DT-HC
		Round Horizontal Termination Cap Square Base (aluminum)	46DVA-HRCS	—	—
		Sconce Termination Cap (aluminum)	46DVA-HSC	—	—
8	6	Storm Collar	46DVA-SC	953	4DT-SC
9	6	1" Firestop	46DVA-FS	963	4DT-FS
10	1	Vinyl Siding Standoff	46DVA-VSS	950	4DT-VS
		Attic Insulation Shield	46DVA-IS	—	—
3	6	6" Pipe Length (galvanized)	46DVA-06	908	4DT-06
3	6	9" Pipe Length (galvanized)	46DVA-09	907	4DT-09
3	6	12" Pipe Length (galvanized)	46DVA-12	906	4DT-1
3	6	24" Pipe Length (galvanized)	46DVA-24	904	4DT-4
3	6	36" Pipe Length (galvanized)	46DVA-36	903	4DT-36
3	6	48" Pipe Length (galvanized)	46DVA-48	902	4DT-48
4	6	8-1/2" Pipe Extension (galvanized)	46DVA-08A	911	4DT-AJ
4	6	16" Pipe Extension (galvanized)	46DVA-16A	917	4DT-AJ14
5	6	45° Elbow (galvanized)	46DVA-E45	945G	4DT-EL45
6	6	90° Elbow (galvanized)	46DVA-E90	990	4DT-EL90
7	6	Adjustable Roof Flashing 0/12 - 6/12	46DVA-F6	943	4DT-AF6
	6	3" Firestop	FS3	—	—
	6	Steep Roof Flashing 7/12 - 12/12	46DVA-F12	943S	—
	8	Horizontal Termination with 1" firestop	BHRT/8	—	—
	8	Flex Adapter Starter.	DVFA/8	—	—
11	1	Restrictor Disk	45D0551	45D0551	—

For more information about, or instructions for, the venting components referenced above, please contact the component manufacturer:

Selkirk Corporation: www.selkirkcorp.com or 800-992-8368

Simpson Duravent: www.duravent.com or 800-835-4429

REPLACEMENT PARTS

LOGS

Item	Description	Qty	HBDV300	HBDV400
1	Rear Log	1	54D5119	54D5023
2	Right Log	1	54D5120	54D5024
3	Left Log	1	54D5121	54D5025
4	Mid Top Log	1	54D5123	54D5026
5	Right Top Log	1	54D5122	54D5027
6	Left Front Log	1	54D5124	54D5028
7	Right Front Twig	1	N/A	54D5029

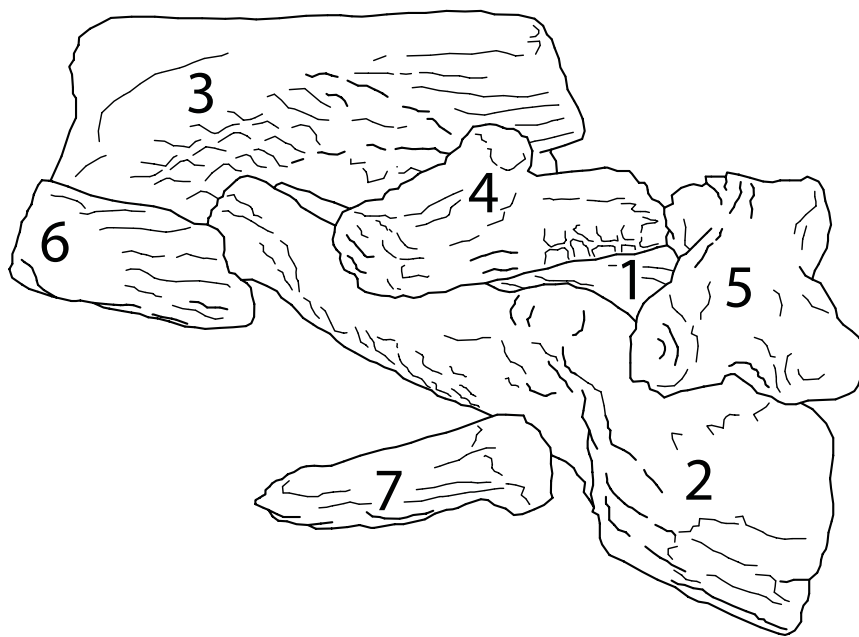

MASSACHUSETTS RESIDENTS ONLY: PLEASE READ AND FOLLOW THESE SPECIAL REQUIREMENTS

NOTE REGARDING VENTED PRODUCTS

This product must be installed by a licensed plumber or gas fitter when installed within the Commonwealth of Massachusetts.

Any residence with a direct vent product must have a CO detector installed in the residence.

Installation of the fireplace or vented gas log in the State of Massachusetts requires the damper to be permanently removed or welded in the fully open position.

In addition, a naturally vented gas log may not be installed in a bedroom or bathroom in the State of Massachusetts.

Flex line installation must not exceed 36 inches and must have a T shutoff valve.

NOTE REGARDING VENT FREE PRODUCTS

This product must be installed by a licensed plumber or gas fitter when installed within the Commonwealth of Massachusetts.

In addition, vent free products may not be installed in a bedroom or bathroom regardless of size or type in the State of Massachusetts.

Flex line installation must not exceed 36 inches and must have a T shutoff valve.

CARBON MONOXIDE DETECTOR REQUIREMENTS

(2) Revise 10.8.3 by adding the following additional requirements:

(a) For all side wall horizontally vented gas fueled equipment installed in every dwelling, building or structure used in whole or in part for residential purposes, including those owned or operated by the Commonwealth and where the side wall exhaust vent termination is less than seven (7) feet above finished grade in the area of the venting, including but not limited to decks and porches, the following requirements shall be satisfied:

1. **INSTALLATION OF CARBON MONOXIDE DETECTORS.** At the time of installation of the side wall horizontal vented gas fueled equipment, the installing plumber or gasfitter shall observe that a hard wired carbon monoxide detector with an alarm and battery back-up is installed on the floor level where the gas equipment is to be installed. In addition, the installing plumber or gasfitter shall observe that a battery operated or hard wired carbon monoxide detector with an alarm is installed on each additional level of the dwelling, building or structure served by the side wall horizontal vented gas fueled equipment. It shall be the responsibility of the property owner to secure the services of qualified licensed professionals for the installation of hard wired carbon monoxide detectors

- a. In the event that the side wall horizontally vented gas fueled equipment is installed in a crawl space or an attic, the hard wired carbon monoxide detector with alarm and battery back-up may be installed on the next adjacent floor level.
- b. In the event that the requirements of this subdivision can not be met at the time of completion of installation, the owner shall have a period of thirty (30) days to comply with the above requirements; provided, however, that during said thirty (30) day period, a battery operated carbon monoxide detector with an alarm shall be installed.

SPECIAL REQUIREMENTS CONTINUED

2. **APPROVED CARBON MONOXIDE DETECTORS.** Each carbon monoxide detector as required in accordance with the above provisions shall comply with NFPA 720 and be ANSI/UL 2034 listed and IAS certified.
 3. **SIGNAGE.** A metal or plastic identification plate shall be permanently mounted to the exterior of the building at a minimum height of eight (8) feet above grade directly in line with the exhaust vent terminal for the horizontally vented gas fueled heating appliance or equipment. The sign shall read, in print size no less than one-half (1/2) inch in size, **“GAS VENT DIRECTLY BELOW. KEEP CLEAR OF ALL OBSTRUCTIONS.”**
 4. **INSPECTION.** The state or local gas inspector of the side wall horizontally vented gas fueled equipment shall not approve the installation unless, upon inspection, the inspector observes carbon monoxide detectors and signage installed in accordance with the provisions of 248 CMR 5.08(2)(a)1 through 4.
- (b) **EXEMPTIONS:** The following equipment is exempt from 248 CMR 5.08(2)(a)1 through 4:
1. The equipment listed in Chapter 10 entitled “Equipment Not Required To Be Vented” in the most current edition of NFPA 54 as adopted by the Board; and
 2. Product Approved side wall horizontally vented gas fueled equipment installed in a room or structure separate from the dwelling, building or structure used in whole or in part for residential purposes.
- (c) **MANUFACTURER REQUIREMENTS - GAS EQUIPMENT VENTING SYSTEM PROVIDED.** When the manufacturer of Product Approved side wall horizontally vented gas equipment provides a venting system design or venting system components with the equipment, the instructions provided by the manufacturer for installation of the equipment and the venting system shall include:
1. Detailed instructions for the installation of the venting system design or the venting system components; and
 2. A complete parts list for the venting system design or venting system.
- (d) **MANUFACTURER REQUIREMENTS - GAS EQUIPMENT VENTING SYSTEM NOT PROVIDED.** When the manufacturer of a Product Approved side wall horizontally vented gas fueled equipment does not provide the parts for venting the flue gases, but identifies “special venting systems,” the following requirements shall be satisfied by the manufacturer:
1. The identification of each “special venting system” shall include either the listing of the website, phone number or manufacturer’s address where the venting system installation instructions can be obtained; and
 2. The “special venting systems” shall be Product Approved by the Board, and the instructions provided with that system shall include a parts list and detailed installation instructions.
- (e) A copy of all installation instructions for the Product Approved side wall horizontally vented gas fueled equipment and all the venting instructions, parts lists, and/or all design instructions for the venting system shall remain with the appliance or equipment at the completion of the installation.

NOTES

LIMITED LIFETIME WARRANTY POLICY

LIFETIME WARRANTY

The following components are warranted for life to the original owner, subject to proof of purchase: Firebox, Combustion Chamber, Heat Exchanger, Grate and Stainless Steel Burners.

FIVE YEAR WARRANTY

The following components are warranted five (5) years to the original owner, subject of proof of purchase: Ceramic Fiber Logs.

BASIC WARRANTY

Monessen Hearth Systems (MHS) warrants the components and materials in your gas appliance to be free from manufacturing and material defects for a period of two years from date of installation. After installation, if any of the components manufactured by MHS in the appliance are found to be defective in materials or workmanship, MHS will, at its option, replace or repair the defective components at no charge to the original owner. MHS will also pay for reasonable labor costs incurred in replacing or repairing such components for a period of two years from date of installation. Any products presented for warranty repair must be accompanied by a dated proof of purchase.

This Limited Lifetime Warranty will be void if the appliance is not installed by a qualified installer in accordance with the installation instructions. The Limited Lifetime Warranty will also be void if the appliance is not operated and maintained according to the operating instructions supplied with the appliance, and does not extend to (1) firebox/burner assembly damage by accident, neglect, misuse, abuse, alterations, negligence of others, including the installation thereof by unqualified installers, (2) the costs of removal, reinstallation or transportation of defective parts on the appliance, or (3) incidental or consequential damage. All service work must be performed by an authorized service representative.

This warranty is expressly in lieu of other warranties, express or implied, including the warranty of merchantability of fitness for purpose and of all other obligations or liabilities. MHS does not assume for it any other obligations or liabilities in connection with sale or use of the appliance. It states that do not allow limitations on how long an implied warranty lasts, or do not allow exclusion of indirect damage, those limitations of exclusions may not apply to you. You may also have additional rights not covered in the Limited Lifetime Warranty.

MHS reserves the right to investigate any and all the claims against the Limited Lifetime Warranty and decide upon method of settlement.

For information about this warranty, contact:

**Technical Services
Monessen Hearth Systems
149 Cleveland Drive
Paris, Kentucky 40361**