Comfort-Aire®

Century®

MARS®
Delivering Confidence

REPLACEMENT PARTS LIST

Packaged Terminal Air Conditioner

PTAC12F130A/

PTAC12F150A

Exploded View

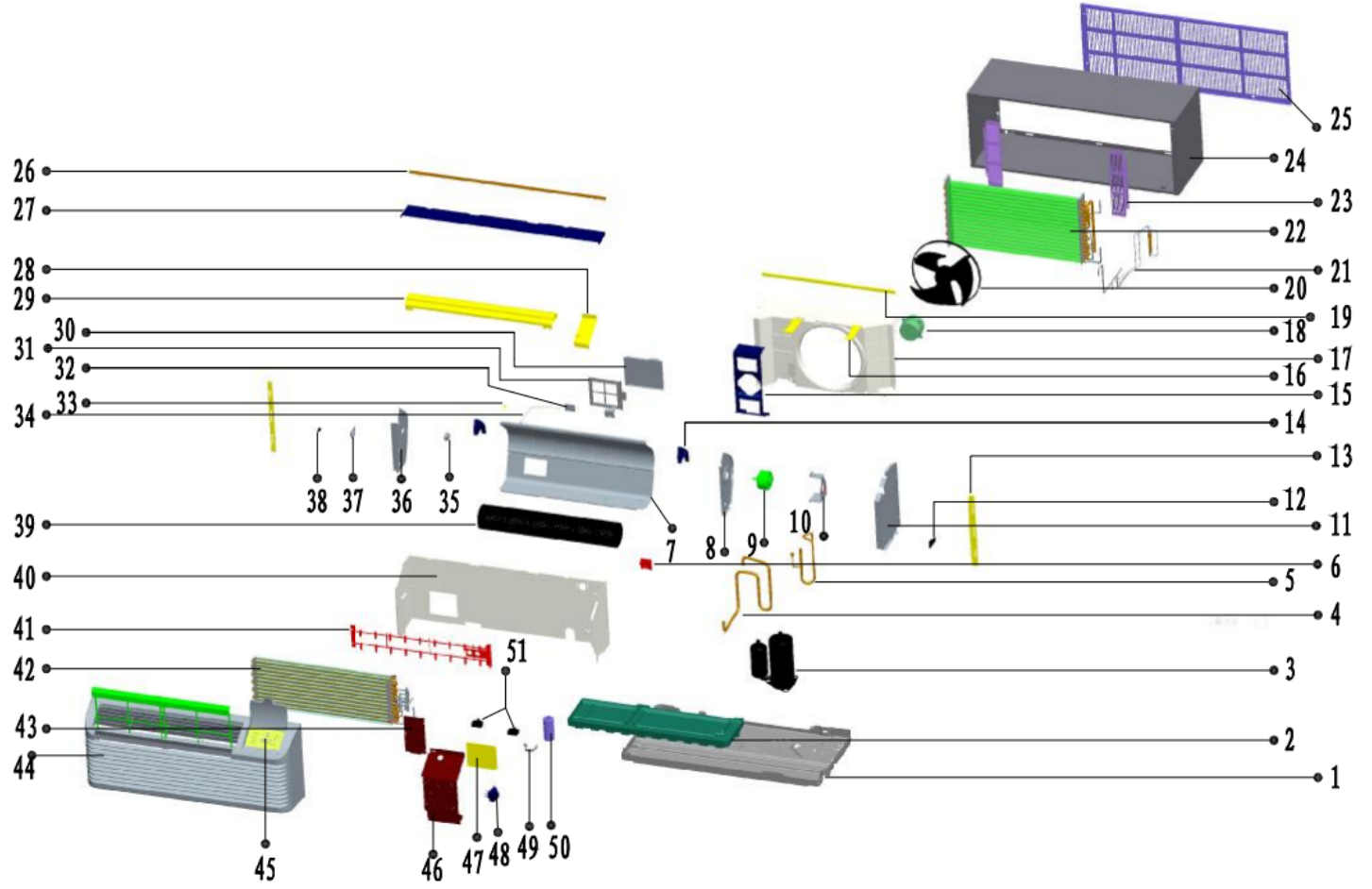
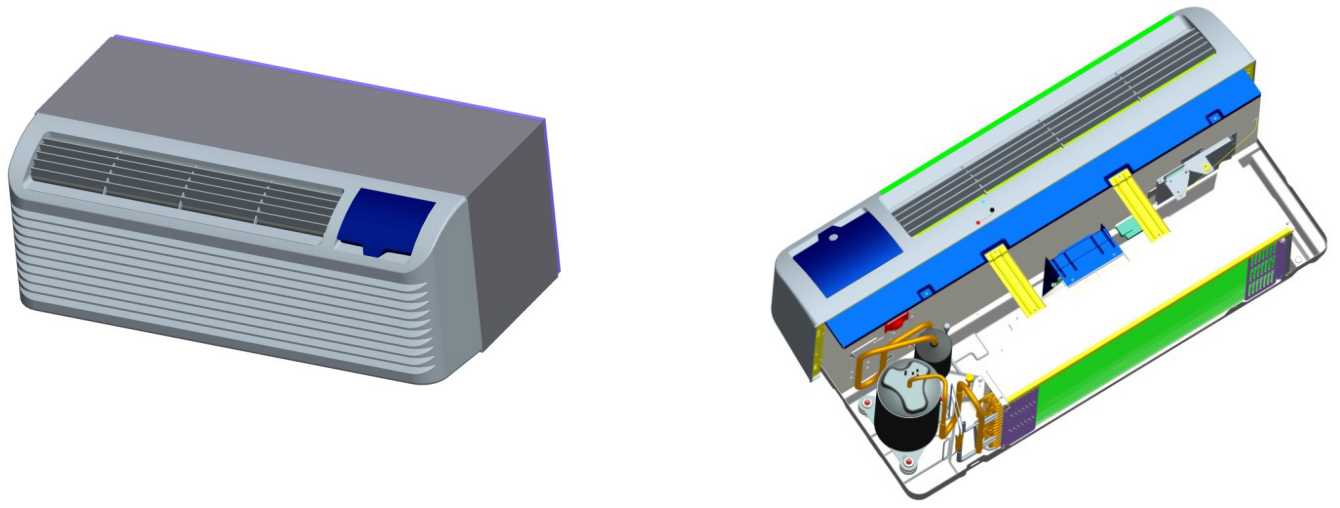

Wiring Diagram

CIRCUIT DIAGRAM 802020590465 V.4

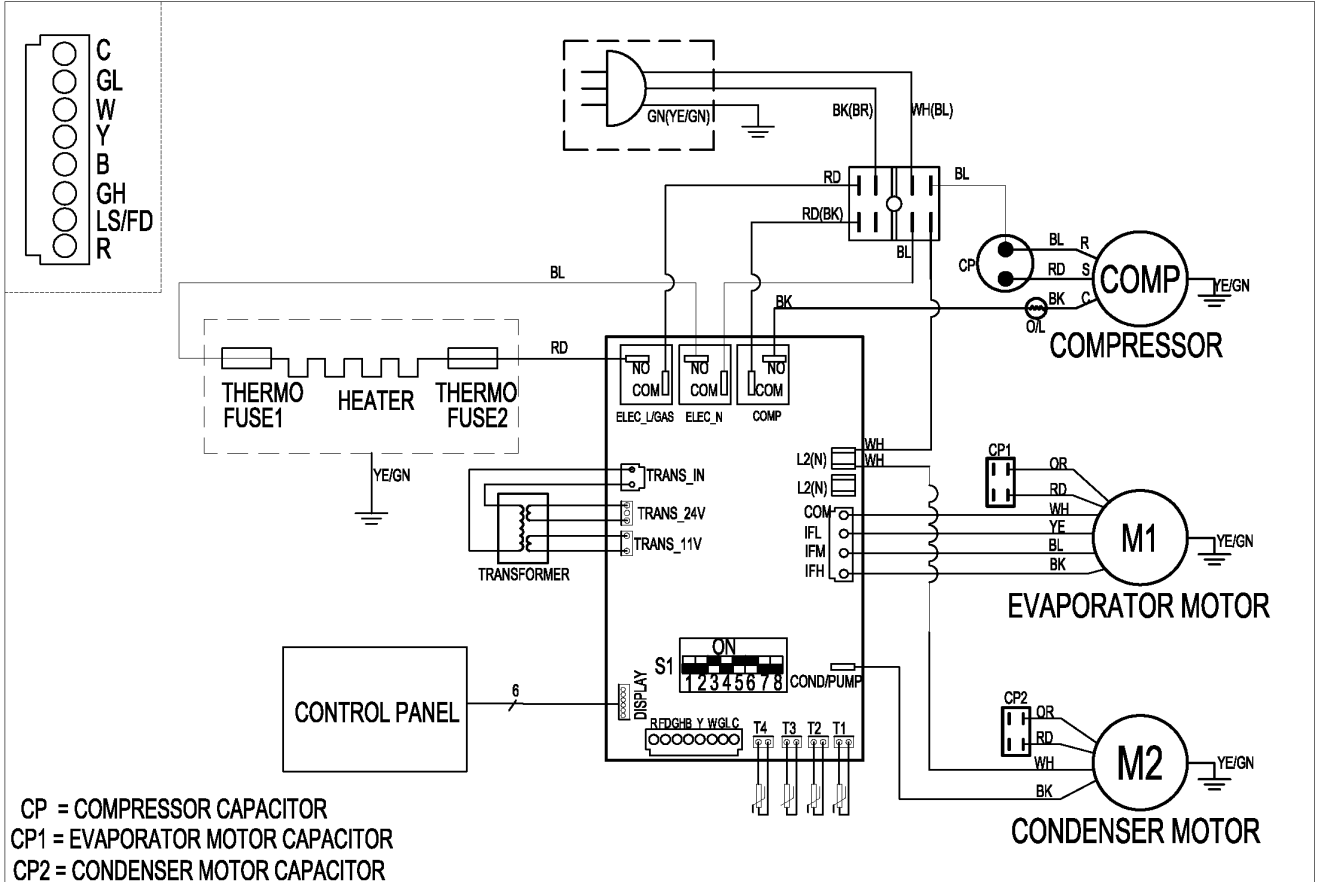

SELECTOR SWITCH (ON: <input type="checkbox"/> OFF: <input type="checkbox"/>)				WIRE COLOR CODE			
S1.1	Anti-cold air	<input type="checkbox"/> Enable <input type="checkbox"/> Disable	S1.5	Room Freeze Protection	<input type="checkbox"/> Enable <input type="checkbox"/> Disable	BL BLUE WH WHITE BR BROWN RD RED GN GREEN BK BLACK OR ORANGE YE YELLOW	
S1.2	Heat Pump	<input type="checkbox"/> Enable <input type="checkbox"/> Disable	S1.6	Electric Memory	<input type="checkbox"/> Enable <input type="checkbox"/> Disable		
S1.3	Electric Heat	<input type="checkbox"/> Enable <input type="checkbox"/> Disable	S1.7	Fan CYC. For Cooling	<input type="checkbox"/> Enable <input type="checkbox"/> Disable		
S1.4	Heat Pump Prior	<input type="checkbox"/> Only panel <input type="checkbox"/> Enable	S1.8	Set temp. step for two degree	<input type="checkbox"/>		
	Electric Heat Prior	<input type="checkbox"/> Enable		Set temp. step for one degree	<input type="checkbox"/>		
CIRCUIT DIAGRAM							DATE
							DWG.NO.
							NO.
						2020-06-08	
						CPS-09ENR1-F+7.PM-4A	
						4	

Replacement Parts List

Location	Description	Qty.	Qty.
1	Chassis assembly	1	801220390279
2	Foam drain tray	1	802220890006
3	Compressor	1	801401400136
4	Air return pipe assy	1	801620890648
5	Discharge pipe assy	1	801620890501
6	Line press plate	1	801120890051
7	The main duct	1	801220590678
8	Right side board assy of air duct	1	801220590681
9	Indoor fan motor	1	802400300023
10	Indoor fan motor bracket	1	801220890158
11	Cable harness assy for left side panel of E-box	1	801220890395
12	Crimp buckle	1	801120890050
13	Left fixing buckle part / Right fixing buckle part	1	801220890167/801220890170
14	Left/Right duct deflector	1	801120890013/801120890014
15	Outdoor fan motor bracket	1	801220890144
16	Connecting plate for outdoor air guide ring	2	801220890166
17	Air guide ring	1	801120890019
18	Outdoor fan motor	1	802400400771
19	Fixing plate of air guide ring	1	801220890190
20	Axial-flow fan blade	1	801120890009
21	Capillary assy	1	801620890646
22	Condenser assy	1	801520590172
23	Air grid	2	801220890146
24	Wall sleeve	1	801220890441
25	Outdoor grille assy	1	801220690038
25.1	Installation buckle of grille	5	801120690007
25.2	Outdoor grille	1	801220690019
26	Panel board support	1	801220890165
27	Top cover	1	801220890179
28	Seal board #2 assy	1	801220590692
29	Air outlet assy	1	801220590690
30	Fresh air inlet assy	1	801220890225
31	Fresh air inlet filter	1	801120890010
32	Fresh air inlet support	2	801220890151
33	Fresh air inlet clamp	1	801120890017
34	Fresh air inlet spring / tube	1	802920890004/801120890028
35	Bearing / Bearing fixed plate	1	802720890002/801220890156
36	Left side board assy of air duct	1	801220590679
37	Fresh air inlet rail	1	801120890012
38	Fresh air inlet lever	1	801120890011
39	Cross-flow fan blade	1	802920890005
40	Septum plate assy	1	801220890506
41	Electric heater	1	802402000250
42	Evaporator assy	1	801520890043
43	Seal board #1 assy	1	801220890175
44	Panel assy	1	801120890020

Replacement Parts List (continued)

Location	Description	Part No.	Qty.
44.1	Front panel	1	801120890021
44.2	Panel fixing buckle	2	801220890192
44.3	Filter	2	801120890022
44.4	Filter rail	1	801120890023
44.5	Outlet air grille	1	801120890024
44.6	Cover of panel	1	801120890025
45	Operation board assy	1	803320590193
45.1	Electronic control box	1	801120890026
45.2	Mask control panel	1	802020590467
45.3	Operation panel	1	803300400018
46	Electric control box flip	1	801220590684
47	Mainboard	1	803300301100
48	Transformer	1	802300200089
49	Capacitor clip	1	801200100002
50	Compressor capacitor	1	802420490009
51	Fan motor capacitor (Indoor) / (Outdoor)	1	802419900166/802401100066
52	Outlet protection net	1	802920590006
53	Indoor temp. sensor	1	802300400088
54	Outdoor temp. sensor	1	802300400077
55	Air return temp. sensor	1	802300400129
56	LCDI power cord	1	802420690015
57	Compressor connecting wire	1	802420390053
58	Refrigerant	0.75KG	800500100004

Due to ongoing product improvements, specifications and dimensions are subject to change and correction without notice or incurring obligations. Determining the application and suitability for use of any product is the responsibility of the installer. Additionally, the installer is responsible for verifying dimensional data on the actual product prior to beginning any installation preparations.

Incentive and rebate programs have precise requirements as to product performance and certification. All products meet applicable regulations in effect on date of manufacture; however, certifications are not necessarily granted for the life of a product. Therefore, it is the responsibility of the applicant to determine whether a specific model qualifies for these incentive/rebate programs.



1900 Wellworth Ave., Jackson, MI 49203 • Ph. 517-787-2100 • www.marsdelivers.com

