

## Spare Parts Catalogue

ASKO Dishwashers \ ASKO 5000 XXL Series  
Type: DW90.2  
Model: D5524 XXL FI US Titan

Prod. No: 1075524156

April 24th 2012

**ASKO Appliances Inc.**

4001 E Plano Parkway #1004001 E Plano Parkway #100  
Plano, Texas 75074

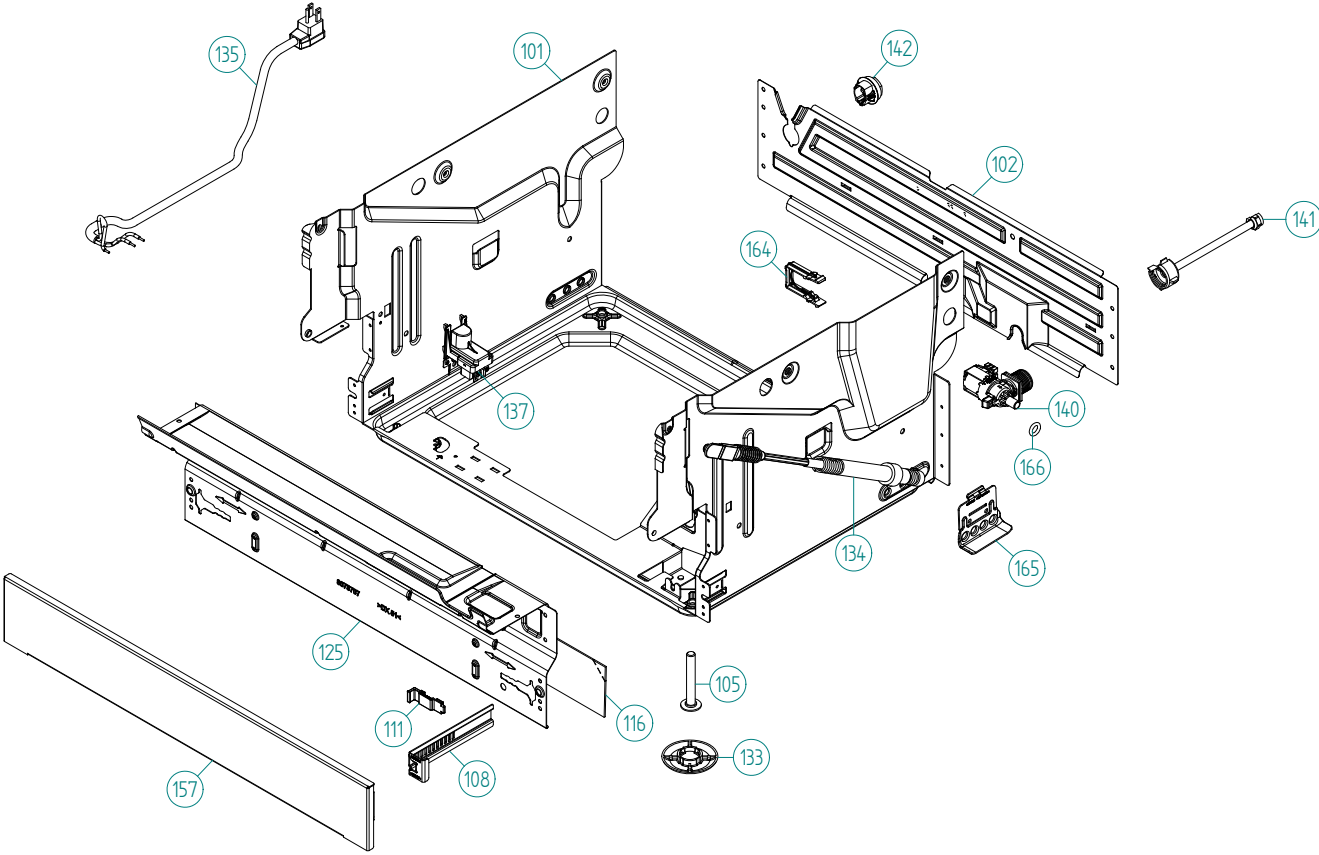

## **Base and related parts**

### **ASKO, D5524 XXL FI US - Titan (DW90.2)**

<b>Pos</b>	<b>Spare part No.</b>	<b>Description</b>	<b>Qty</b>	<b>Comment</b>
101	8801387	BOTTOM OUTER COMPL.	1 Pc's	
101-a	8901104	Screw 20 Torx Machine	2 Pc's	
101-b	8901110	Screw w/ORing DW 05/06 25T	4 Pc's	
102	8078006	REAR PANEL	1 Pc's	
102-a	8902357	Screw	4 Pc's	
105	8074228	Leveling Foot M10X75 T30 8.8 FZB	3 Pc's	
108	8073480	Toe Kick bracket Right & Left	2 Pc's	
111	8073481-49	Toe Kick Bracket Clip L-Grey	2 Pc's	
116	8082272	Sound Absorb Protective Plate	1 Pc's	
125	8078007-81	GUARD PLATE FLANGED TITANIUM	1 Pc's	
125-a	8902357	Screw	4 Pc's	
133	8051957	Glide Foot	3 Pc's	
134	8088593	DOORSRING CPL HARD DAMPER BLU	2 Pc's	
135	8083262	CORD SET 15A AMERICA	1 Pc's	
137	8083041	Terminal Block w/RFI DW70	1 Pc's	
137-a	8901097	Screw Terminal	1 Pc's	
140	8801376	KIT INL.VALVE/LOCKARM SING120V	1 Pc's	
141	8079522	PEX Inlet hose DW	1 Pc's	
142	8006948	Grommet	1 Pc's	
157	8073566-81	Toe Kick Mettalic	1 Pc's	
164	8079597	LOCK ARM INLET VALVE	1 Pc's	
165	8078013	DOOR SPRING HOLDER	2 Pc's	
165-a	8902362	SCREW RTK ST 4,2X9,5 FZB WAX.	2 Pc's	
166	8901779	O-RING 10X3,5	1 Pc's	

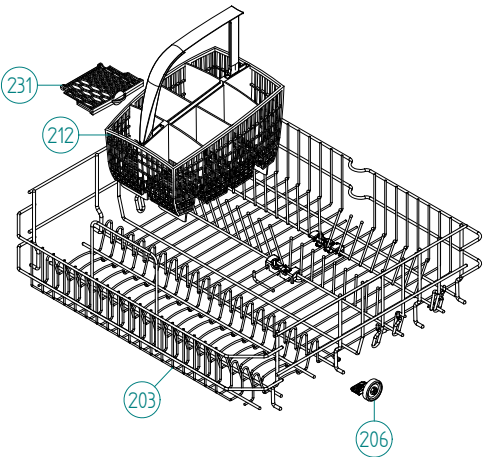
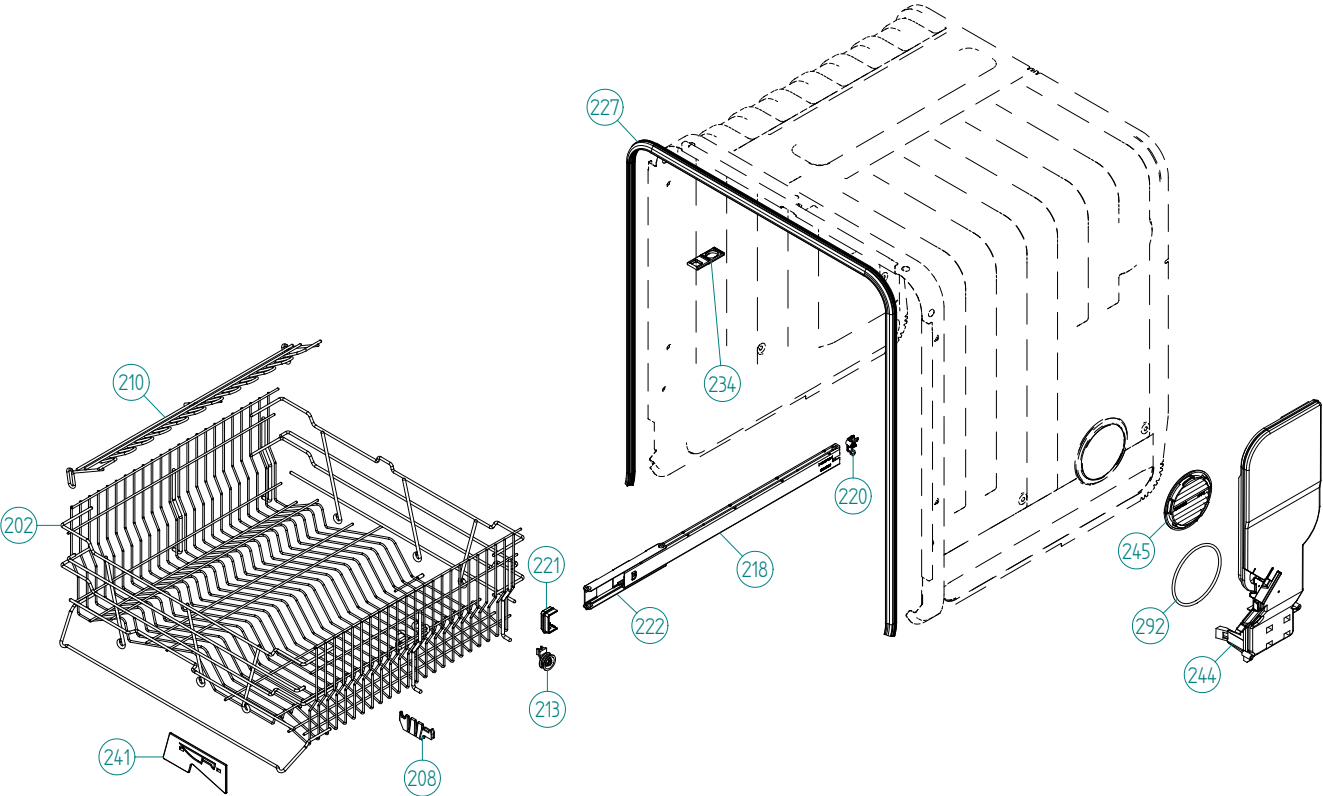

## **Baskets and related parts**

### **ASKO, D5524 XXL FI US - Titan (DW90.2)**

<b>Pos</b>	<b>Spare part No.</b>	<b>Description</b>	<b>Qty</b>	<b>Comment</b>
201	8057056	-	1 Pc's	Not a spare part
202	8801315-36	UPPER BASKET EXCL D.GREY 07	1 Pc's	
203	8801316-36	LOWER BASKET EXCL D.GREY 07	1 Pc's	New design
206	8079257-77	WHEEL FOR LOW DISHW BASKET CPL	8 Pc's	
208	8071214-77	Knife Holder 05/06 DW	2 Pc's	
210	8071337-36	Cup Shelf Wine Glass 05/06 DW	1 Pc's	
212	8801396-77	Cutlery Bskt for Stnd Tines	1 Pc's	
213	8058498-77	Upper Basket Wheel	4 Pc's	
218	8801350	DW Upper Basket Guide Rail Kit	2 Pc's	
220	8057978-77	DW Rail Stop - Back Grey	2 Pc's	
221	8088703-77	BASKET STOP	2 Pc's	
222	8801349-77	KIT BALL HOLDER INCL. BALLS	1 Pc's	
227	8057489-F	DOOR STRIP XXL DW70	1 Pc's	
231	8079251-77	DOOR CUTLERYBASKET UL4	1 Pc's	
234	8070649	Lock Hitch Int	1 Pc's	
234-a	8070654	LOCK WASHER INTEGR.	1 Pc's	
234-b	8901104	Screw 20 Torx Machine	1 Pc's	
241	8057506-77	Knife Stop	1 Pc's	
244	8078300	AIRBREAK STD. DW70 UL4	1 Pc's	
245	8057536-77	LOCKRING AIREBREAKER GREY	1 Pc's	
292	8901778	O-RING 95X4	1 Pc's	

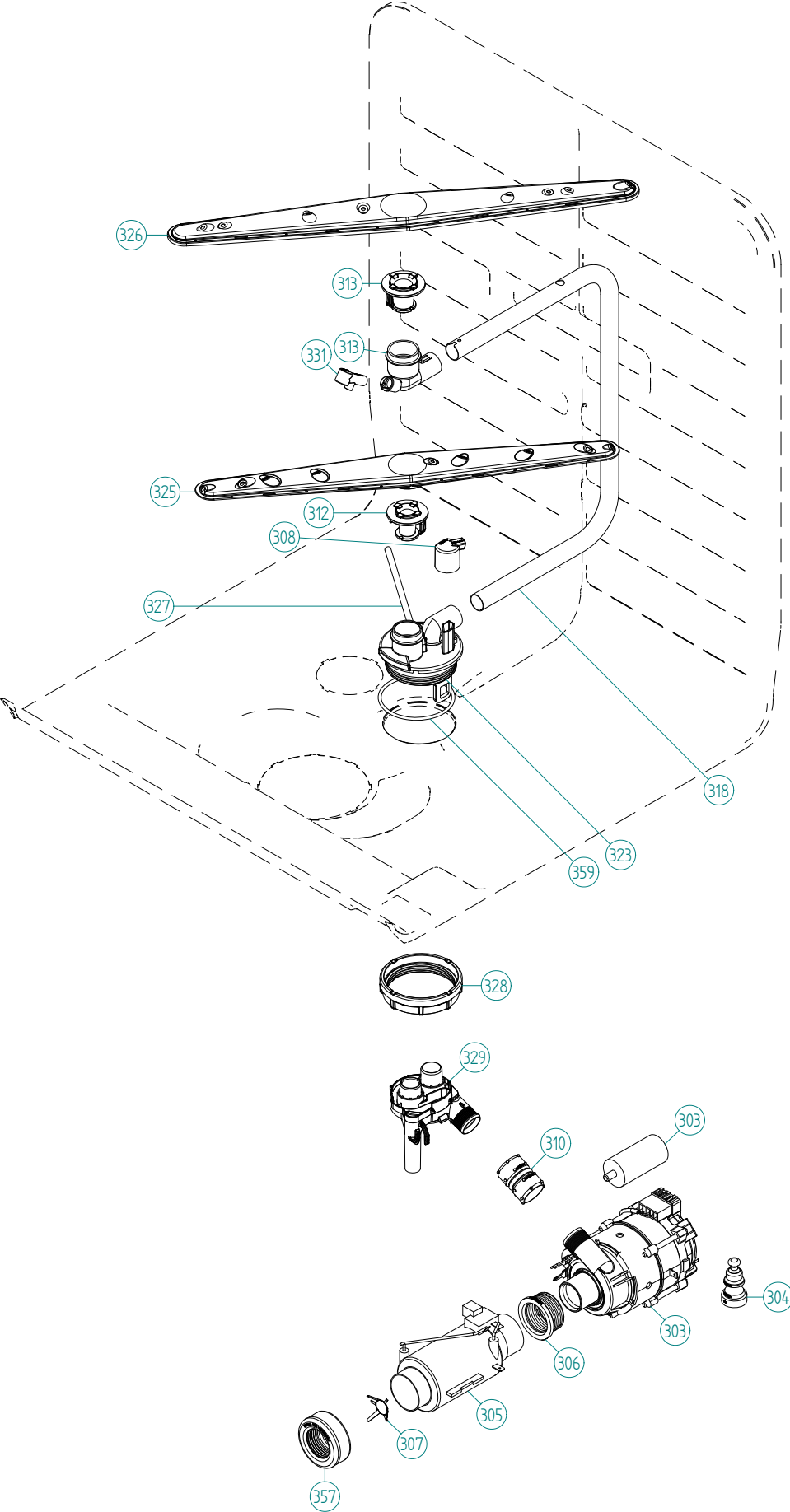

## Wash System

### ASKO, D5524 XXL FI US - Titan (DW90.2)

Pos	Spare part No.	Description	Qty	Comment
301	8078001	-	1 Pc's	Not a spare part
303	8078082	CIRC.PUMP 120V 60HZ	1 Pc's	
303-a	8083804	Capacitor 7 0UF 400V P2 CLASS	1 Pc's	
304	8079683	RUBBER DAMPER HI CIRC.PUMP UL4	1 Pc's	
305	8801463	HEATER W.INSERT 1200W120V DW70	1 Pc's	
306	8079531	SEALING HEATER DW70 UL4	1 Pc's	Only 1 pc from 2009-06-11
307	8079575	INSERT FOR HEATER	1 Pc's	
308	8073385-77	Cup Drainage Gray	1 Pc's	
310	8801409	KIT HOSE INCL.CLAMPS CIRK.PUMP	1 Pc's	
312	8801270	Spray Arm Bearing Kit	1 Pc's	
313	8801268	Spray Arm Bearing Kit	1 Pc's	
313	8801268	KIT SPRAYARM BEAR. UPPER DW20	1 Pc's	
318	8073387-E	SPRAY PIPE Ø18 XXL	1 Pc's	
323	8801270	KIT SPRAYARM BEAR. LOW NOZZLE	1 Pc's	
325	8072891	Spray Arm Lower Complete	1 Pc's	
326	8072894	Spray Arm Upper Complete	1 Pc's	
327	8073381	Tube Pot Rinse	1 Pc's	
327-a	8902085	Screw 20T for Plastic	2 Pc's	
328	8071607	Locking Spray Pipe Bearing	1 Pc's	
329	8078086	INTERMEDIATE	1 Pc's	
331	8072543-77	Spray Nozzle	1 Pc's	For part no 8073381 and 8076902-L-77
357	8083603	SEALING HEATER BOTTOM SUMP	1 Pc's	
359	8901765	ORing det Comp 03/04 DW	1 Pc's	

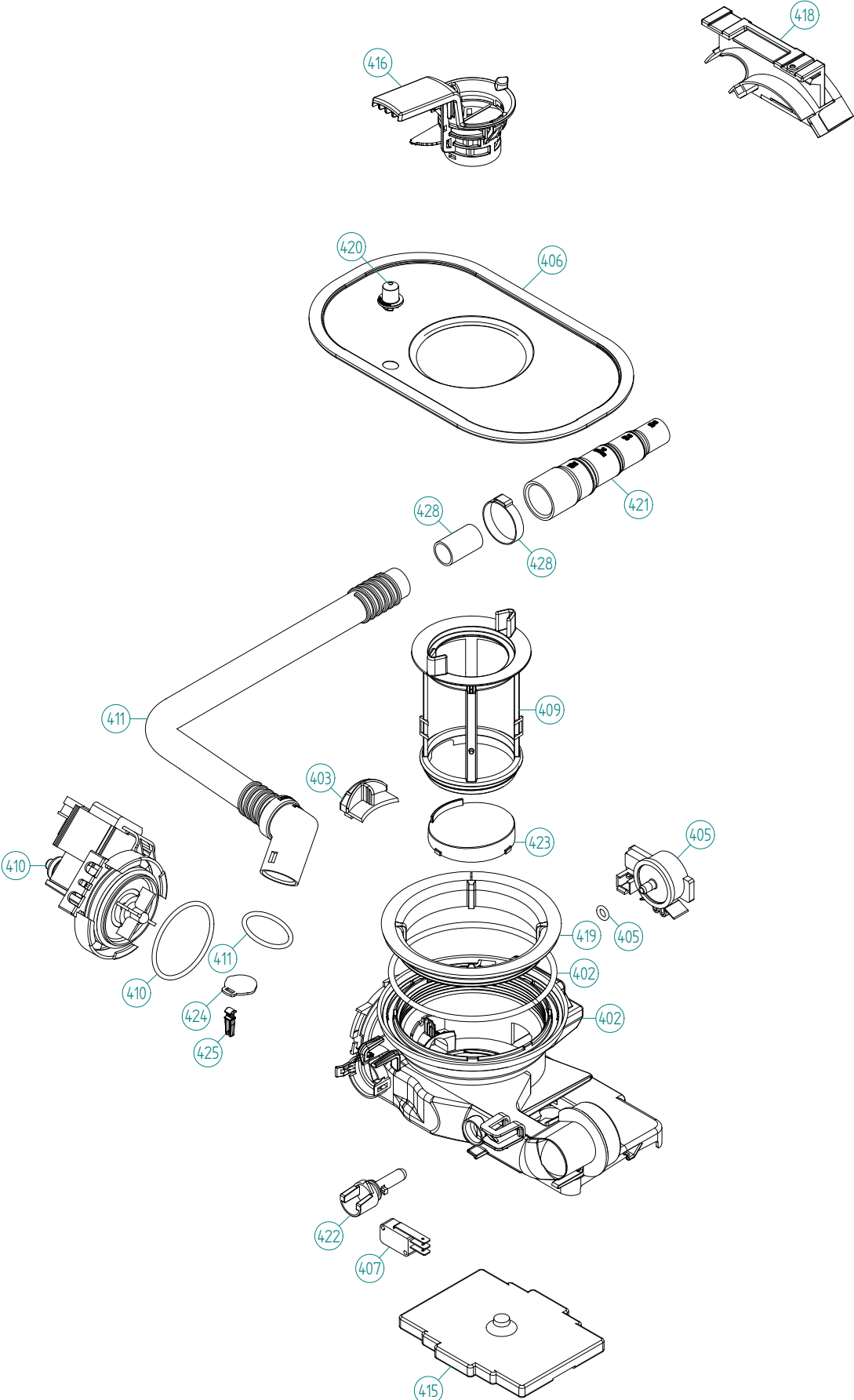



## **Bottom well and related parts**

### **ASKO, D5524 XXL FI US - Titan (DW90.2)**

<b>Pos</b>	<b>Spare part No.</b>	<b>Description</b>	<b>Qty</b>	<b>Comment</b>
402	8084691	BOTTOM WELL PRESSURE SENS. UL4	1 Pc's	
402-a	8081039	O-RING 110x4	1 Pc's	
403	8078033	Rinse Cap Bottom Well - Yellow	1 Pc's	
405	8073839	Pressure Sensor	1 Pc's	
405-a	8074040	O-Ring-Press Sensor	1 Pc's	
406	8074364	Strainer DW20	1 Pc's	
407	8073835	Microswitch Float	1 Pc's	
409	8078038-77	Pipe Filter DW70	1 Pc's	
410	8078089	Drain Pump 120V 60Hz	1 Pc's	
410-a	8002584	ORing Drain Pump 05/06 DW	1 Pc's	
411	8083478	OUTLET HOSE HARD END CUFF US	1 Pc's	
411-a	8901768	O-RING 32,3X3 (BD)	1 Pc's	
415	8078025	Float	1 Pc's	
416	8078039-77	Strainer Basket Grey	1 Pc's	
418	8072528-77	Holder Outlet Hose	1 Pc's	
418-a	33700450	Cable Strip	1 Pc's	
418-b	8902072	SCREW PT KB40X10 WN1442 GALV	1 Pc's	
419	8072848	Lockring Bottom Well	1 Pc's	
420	8074760-77	Ventilator	1 Pc's	
421	8075321	End Cuff	1 Pc's	
422	8078096	Thermistor	1 Pc's	
423	8080827	BOTTOM LID TUBE FILTER	1 Pc's	
424	8079691	SEALING FLAT NON RETURN VALVE	1 Pc's	
425	8083211	HOOK NON RETURN VALVE	1 Pc's	
428	8079698	SLEEVE OUTLET HOSE USA	1 Pc's	
428-a	8052239	Hose Clamp	1 Pc's	

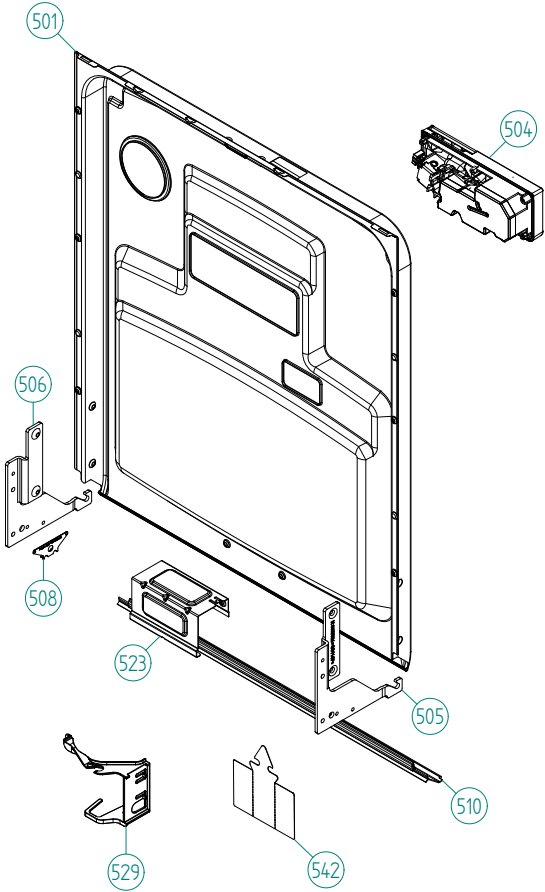
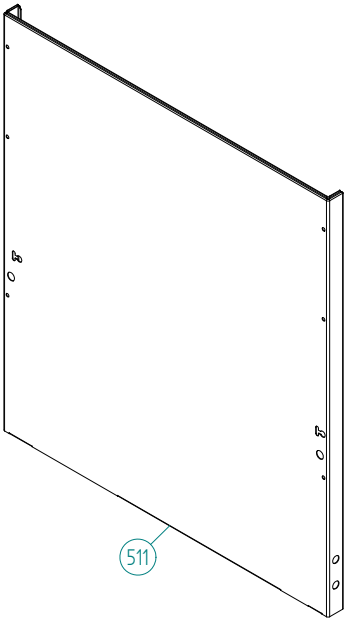

## ***Inner door, panel and related parts***

**ASKO, D5524 XXL FI US - Titan (DW90.2)**

<b>Pos</b>	<b>Spare part No.</b>	<b>Description</b>	<b>Qty</b>	<b>Comment</b>
501	8801383	DOOR INNER W.OUT FAN INT 86XXL	1 Pc's	
501-b	8902121	SCREW A2-MKFT 5X10	4 Pc's	
504	8083095	COMBIDISP AWECO REED 120V DW90	1 Pc's	
505	8089953	HINGE RIGHT PAINTED	1 Pc's	
506	8089952	HINGE LEFT PAINTED	1 Pc's	
507	8057530	Screw hinge 05	2 Pc's	
507-a	33500262	Nut Term Block	2 Pc's	
508	8088699	WASHER HINGE BEARING	2 Pc's	
510	8801294	DOOR SEAL LOWER W.CORNER GUARD	1 Pc's	
511	8078018-P-81	DOOR OUTER HIGH EU INT TITAN	1 Pc's	
511-a	8900646	Screw 20 Torx SS	6 Pc's	
523	8078011	INTERM.STAY XXL EU	1 Pc's	
523-a	8902357	Screw	2 Pc's	
523-b	8900646	Screw 20 Torx SS	2 Pc's	
529	8074278	Bracket for harness	1 Pc's	
542	8079686	COVER, CABLES DW70	1 Pc's	

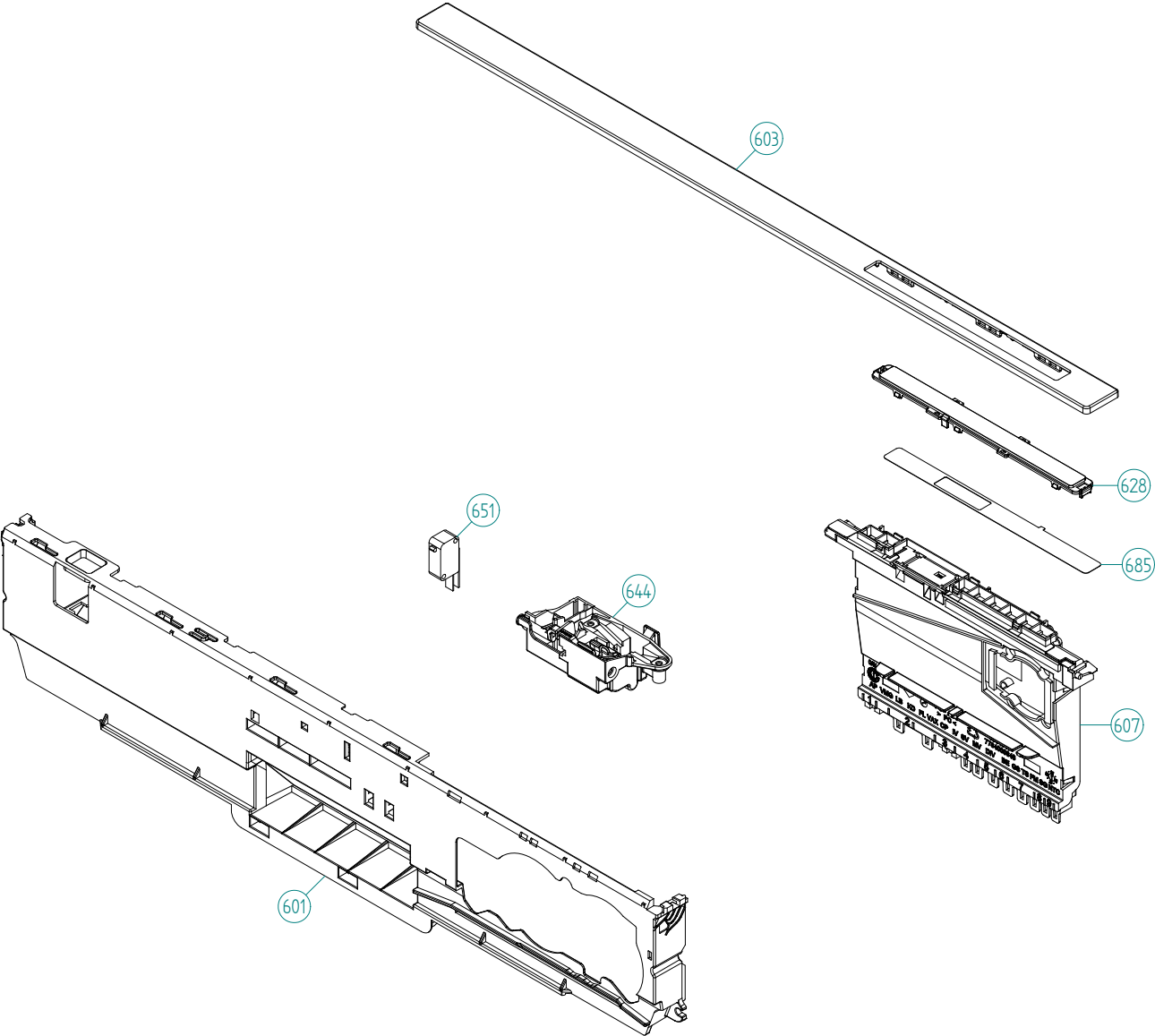

## Control panel and related parts

### ASKO, D5524 XXL FI US - Titan (DW90.2)

Pos	Spare part No.	Description	Qty	Comment
601	8084001-UL	PANEL DW90 INTEGRATED LOCK UL4	1 Pc's	
602	8090946	PROG.INFO.LABEL D55-5624 ENG	1 Pc's	
602	8090947	PROG.INFO.LABEL D55-5624 FR	1 Pc's	
603	8084046-81	LENS DW90.2 ASKO GRAPHIC	1 Pc's	
607	8801483	CONTR. UNIT COMPL DW90.2 WH/BL	1 Pc's	
610	8079517	CABLE SET THERMISTOR UL4	1 Pc's	
614	8078068	CABLE SET CI.PUMP IN.VALVE UL4	1 Pc's	
616	8078067	CABLE SET FLOW & PRESSURE UL4	1 Pc's	
618	8079511	CABLESET POWER TOUCH UL4	1 Pc's	
619	8084063	CABLESET DOOR WITH REED UL4	1 Pc's	
622	8078063	CABLE SET DRAIN UL4	1 Pc's	
628	8084019	TOUCH LENS DW90.2 UL4	1 Pc's	
644	8073670	Lock Complete Integrated	1 Pc's	
644-a	8902085	Screw 20T for Plastic	2 Pc's	
651	8073836	MICROSWITCH DOOR	0 Pc's	
685	8091974-69	DECOR INSERT DW90.2 2BU GR.UL4	1 Pc's	
690	8090780	INSTRUCTIONS D5524 FI ENG	1 Pc's	
690	8090781	INSTRUCTIONS D5524 FI FR	1 Pc's	

- KD/CD: COMBI DISPENSER
  - CP: CIRCULATION PUMP
  - DIV: WATER DIVERTER VALVE
  - AP/DP: DRAIN PUMP
  - DR: DOOR
  - LB/DS: DOOR SWITCH
  - F: FILTER
  - FM: FLOW METER
  - FL/FN 1: FAN DOOR
  - FAN/FN 2: FAN BOTTOM
  - FS: FLOAT SWITCH
  - EL/HE: HEATING ELEMENT
  - HE (PTC): HEATING ELEMENT PTC
  - BE/HL: HALOGEN LAMP
  - HS: HUMIDITY SENSOR
  - IS: ILLUM. SWITCH
  - IV: INLET VALVE
  - I2C: I2C
  - TB/MS: MAIN SWITCH
  - MV: MIX VALVE
  - TS/PS: PRESSURE SENSOR
  - VMG/RAS: RINSE AID SENSOR
  - SL: STATUS LIGHT
  - SG/SS: SALT SENSOR
  - SV: SALT VALVE
  - NTC/TH: THERMISTOR
  - GS/TS: TURBIDITY SENSOR
  - UART: UART
  - VAX: VAX ACTUATOR
  - HWC: HOT WATER CIRCUIT
- WIRES IN ALL MACHINES  
 - - - INTERNAL CONNECTION  
 - . - WIRES IN SOME MACHINES

**RESISTANCES AT ROOM TEMPERATURE (CA. 20°C/68°F)**  
**VALUES WITH +/-10% ARE REGARDED AS NORMAL**

COMPONENT	RESISTANCE
RADIO INTERFERENCE SUPPRESSION FILTER	1 MOHM
HEATING ELEMENT 1200W 120V	12 OHM
HEATING ELEMENT 1600W 230V	32 OHM
HEATING ELEMENT 2040W 230V	25 OHM
THERMISTOR	60 KOHM
COMBINED DISPENSER 120V	0,28 KOHM
COMBINED DISPENSER 230V	1,32 KOHM
CIRCULATION PUMP 120V 60HZ	32 OHM
CIRCULATION PUMP 230V 50HZ	110 OHM
CIRCULATION PUMP 220V 60HZ	56 OHM
DRAIN PUMP 120V 60HZ	25 OHM
DRAIN PUMP 230V 50HZ	150 OHM
DRAIN PUMP 230V 60HZ	85 OHM
SPRAY ARM DIVIDER 120V 60HZ	2,6 KOHM
SPRAY ARM DIVIDER 230V 50/60HZ	8,5 KOHM
INLET VALVE SINGLE INCL. 120V	0,95 KOHM
INLET VALVE SAFETY INCL. 120V	0,5 KOHM
INLET VALVE SINGLE INCL. 230V	3,9 KOHM
INLET VALVE SAFETY INCL. 230V	2 KOHM
SALT VALVE 120V	0,65 KOHM
MIX VALVE 120V	0,65 KOHM
SALT VALVE 230V	3 KOHM
MIX VALVE 230V	2,3 KOHM
HALOGEN LAMP 5W 12V	<10 KOHM
WAX MOTOR	1,1 KOHM
FAN MOTOR 120V	0,18 KOHM
FAN MOTOR 230V	0,85 KOHM
FAN MOTOR 2 120V	0,22 KOHM
FAN MOTOR 2 230V	0,90 KOHM

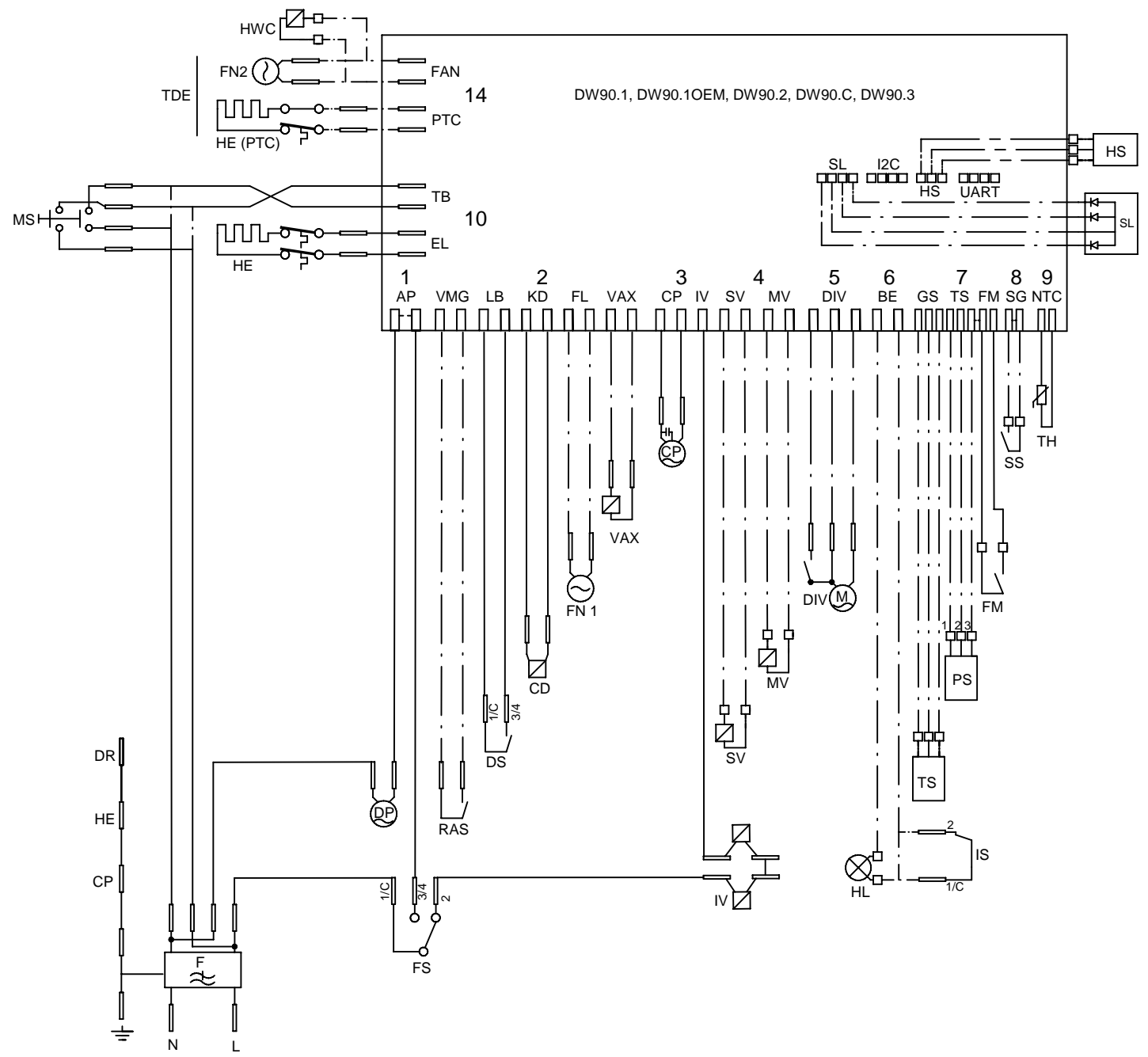

CIRCUIT DIAGRAM DW90.1, DW90.1OEM, DW90.2, DW90.C, DW90.3

80 840 68-01

This document must not be copied without our written permission, and the contents thereof must not be imparted to a third party nor be used for any unauthorized purpose. Contravention will be prosecuted. Asko Appliances AB

DW90.1, DW90.1 OEM, DW90.2		
After power on, wait until LCD is turned on. Then, within 5sec, press first T1 and directly after T2. Hold both buttons pressed during 5sec to enter service menu.		
Failure	F:XX	Last failure read out. F10 Overfillig, F11 Drain, F12 Water inlet, F40 Valve leakage, F41 Temp. stop, F42 Thermistor, F43 Pressure sensor, F44 Turbidity sensor, F45 Diverter
START (T2)		
Diagnostic	d:01	Mix valve and inlet valve on (1 sec delay between mixventil and inlet valve)
	d:02	Inlet valve on
	d:03	Salt Valve on
	d:04	Combi dispenser on
PROG (T1)	d:05	Circulation and spolarmsväxlaren (if available) shall alternate between positions 1 and 3 every 30 seconds
	d:06	Circulation and heaters - max 75 ° C
	d:07	Fan and vax actuator
	d:08	Drain Pump on
	d:00	No components on
START (T2)		
Water inlet	P:0	Normal water intake, default
	P:5	Water intake increased +5%
	P:10	Water intake increased +10%
PROG (T1)	P:15	Water intake increased +15%
	L:0	Time, flow meter disconnected, inlet time: no of pulses x 0.068 [s]
	L:5	Timed water intake increased +5%
	L:10	Timed water intake increased +10%
	L:15	Timed water intake increased +15%
START (T2)		
Variant, DW90.1	U:1 DW90.1	Variant 1 and 2, the default setting (temperature, drying)
	U:2 DW90.1 OEM	
	U:3 DW90.1	Variant 3 and 4 (Temperature, Drying, Delayed Start)
	U:4 DW90.1 OEM	
PROG (T1)	U:5 DW90.1	Variant 5 and 6 (Set of time program, Temperature, Drying, Time saving, Delayed Start)
	U:6 DW90.1 OEM	
	U:7 DW90.1 and DW90.1OEM	Variant 7 (Set of time program, Temperature, Drying, Time-saving, Upper Lower basket wash, Delayed Start)
Variant, DW90.2	U:1	Variant 1, the default setting (temperature, drying)
	U:2	Variant 2 (Temperature, Drying, Delayed Start)
PROG (T1)	U:3	Variant 3 (Temperature, Drying, Delayed Start, Set of time program)
	U:4	Variant 4 (Temperature, Drying, Delayed Start, Set of time program, Time saving)
START (T2)		
Region	EU	Region Europe, the default setting
PROG (T1)	US	Region USA
	AU	Region Australia
START (T2)		
Fan Sequence	Y:0	No fan sequence during wash cycle
PROG (T1)	Y:1	Fan sequence during the wash cycle but not in Normal program, the default setting
	Y:2	Fan in sequence during the all wash cycles
START (T1)		
TDE & HWC, only DW90.2	A:0	Turbo Drying Express and Heat Water Circuit off, default setting
PROG (T1)	A:1	Turbo Drying Express on
	A:2	Heat Water Circuit on
START (T2)		
ECO, only DW90.1	E:0	ECO off, the default setting
PROG (T1)	E:1	ECO on, when the machine is connected to hot water consumed less electrical energy to heat water and program time is shortened.
START (T2)		
Super rinse	S:0	Super Rinse, default
PROG (T1)	S:1	Super Rinse on. Adding two extra rinses.
START (T2)		
Total restart	r:0	No restart on the next press T2, default
PROG (T1)	r:1	Total restart at the next press T2
START (T2)		

DW90.3		
To enter service menu, press T1 and T2 at power on.		
START (T2)		
Failure	CU Date code xxxx	Control unit manufacturing date: year week
	Software xxx	Software version
PROG (T1)	3 FAIL. xxxx	Last failure
	2 FAIL. xxxx	2nd last failure
	1 FAIL. xxxx	3rd last failure
START (T2)		
Diagnostic	Testing	No component on
	Testing Valve A: XXX	Mix valve on and inlet valve on (1 sec delay between mix valve and inlet valve), flow in pulses(XXX) by flow meter
	Testing Valve B: XXX	Inlet valve on (1 sec delay), flow in pulses(XXX) by flow meter
PROG (T1)	Testing Salt	Salt valve on
	Testing Dispenser	Kombi dispenser on
	Testing Cir: XXV	Circulation pump on and the water diverter valve(if present) shall change between position 1 and 3 every 30 second, turbidity(XX) in Volt
	Testing Heater: XX°C	Circulation pump and heater on until max 75°C, temp displayed in °C or °F according to machine setup
	Testing Fan: XXXX	Fan and wax actuator on, humidity value(XXXX Hz)
	Testing TDE	TDE fan on and TDE heater on
	Testing Drain: XXV	drain pump on, pressure sensor value(XX) in Volt
START (T2)		
Water inlet	Water volume 0	Normal water intake, default
	Water volume +5%	Water intake increased +5%
	Water volume +10%	Water intake increased +10%
	Water volume +15%	Water intake increased +15%
PROG (T1)	Water volume Time 0	Time, flow meter disconnected, inlet time: no of pulses x 0.068 [s]
	Water volume Time +5%	Timed water intake increased +5%
	Water volume Time +10%	Timed water intake increased +10%
	Water volume Time +15%	Timed water intake increased +15%
START (T2)		
LCD-cont	Contrast 0	LCD-contrast 0
	Contrast +1	LCD contrast +1
PROG (T1)	Contrast +2	LCD contrast +2
	Contrast -1	LCD contrast -1
START (T2)		
TDE	Turbo Drying On	Turbo Drying Express On
PROG (T1)	Turbo Drying Off	Turbo Drying Express off
START (T2)		
Fan seq.	Fan Off	No fan sequence during wash cycle
PROG (T1)	Fan 1 On	Fan sequence during the wash cycle but not in Normal program, the default setting
	Fan 2 On	Fan in sequence during the all wash cycles
START (T2)		
DUO	DUO Off	DUO Off
PROG (T1)	DUO On	DUO On, to activate program like Sani, Pots & pans
START (T2)		
Region	Region EU	Region Europa, default setting
	Region US	Region USA
PROG (T1)	Region AU	Region Australien
START (T2)		

## Displays

### DW90.1

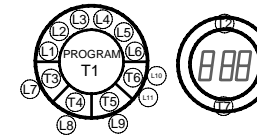

Panel type DW90.1, L = LED, T = Push-button

### DW90.1 OEM

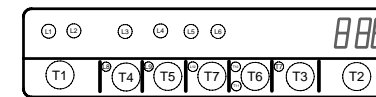

Panel type DW90.1 OEM, L = LED, T = Push-button

### DW90.2

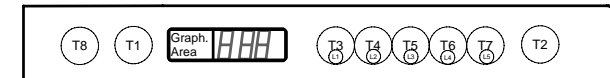

Panel type DW90.2, L = LED, T = Push-button

### DW90.3

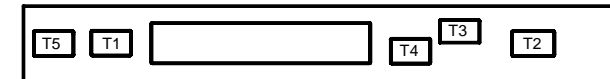

Panel type DW90.3, T = Touch areas

CIRCUIT DIAGRAM DW90.1, DW90.1OEM, DW90.2, DW90.C, DW90.3

80 840 68-01

This document must not be copied without our written permission, and the contents thereof must not be imparted to a third party nor be used for any unauthorized purpose. Contravention will be prosecuted. Asko Appliances AB