

INSTALLER: Leave this manual with the appliance.
CONSUMER: Retain this manual for future reference.

WARNING: If not installed, operated and maintained in accordance with the manufacturer's instructions, this product could expose you to substances in fuel or from fuel combustion which can cause death or serious illness.

Attention: Check local codes for venting requirements.

⚠ WARNING

FIRE OR EXPLOSION HAZARD

Failure to follow safety warnings exactly could result in serious injury, death or property damage.

- Do not store or use gasoline or other flammable vapors and liquids in the vicinity of this or any other appliance.
- **WHAT TO DO IF YOU SMELL GAS**
 - Do not try to light any appliance.
 - Do not touch any electrical switch; do not use any phone in your building.
 - Leave the building immediately.
 - Immediately call your gas supplier from a neighbor's phone. Follow the gas supplier's instructions.
 - If you cannot reach your gas supplier, call the fire department.
- Installation and service must be performed by a qualified installer, service agency or the gas supplier.

**POWER-VENT
HIGH-EFFICIENCY FIREPLACE**

**MODELS
FG28BM(N,P)-1
IG28BM(N,P)-1**

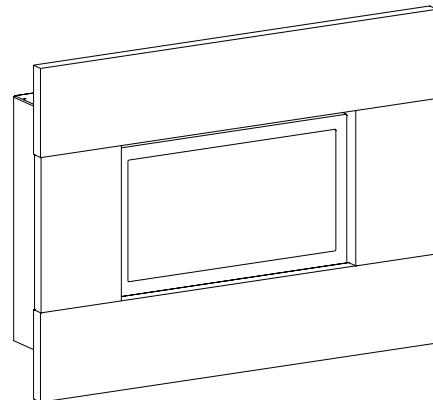

This appliance may be installed in an aftermarket, permanently located, manufactured home (USA only) or mobile home, where not prohibited by state or local codes.

This appliance is only for use with the type of gas indicated on the rating plate. This appliance is not convertible for use with other gases, unless a certified kit is used.

⚠ WARNING



**HOT GLASS WILL
CAUSE BURNS.
DO NOT TOUCH GLASS
UNTIL COOLED.
NEVER ALLOW CHILDREN
TO TOUCH GLASS.**

A barrier designed to reduce the risk of burns from the hot viewing glass is provided with this appliance and shall be installed for the protection of children and other at-risk individuals.

**NATIONAL
FIREPLACE
INSTITUTE**



CERTIFIED
www.nficertified.org

We suggest that our gas hearth products be installed and serviced by professionals who are certified in the U.S. by the National Fireplace Institute® (NFI) as NFI Gas Specialists.

TABLE OF CONTENTS

SECTION	PAGE
Important Safety Information	3
Safety Information for Users of LP-Gas.....	4
Requirements for Massachusetts	5
Introduction.....	6
Specifications and Accessories	7
Installation and General Safety Information	8
Gas Supply	9
Vent Clearances	10
Venting Requirements	11-12
Vent Adaptor Kits	12
PVVK-CFA Flex Vent Kit.....	12
PVVC Termination Cap Vent Kit.....	13
Vent Examples for Single Flue	14-15
PVCA Horizontal Colinear Direct Vent Adaptor	16
Colinear Transition Vent Kit	17
Direct Vent and Colinear Vent Examples.....	18-20
PVVK-24H and PVVK-48H Vent Kit	21-23
Rough Framing Dimensions	24
Insert Into Masonry Fireplace	25
Clearance to Combustibles	26
Specifications	27-28
Gas Connection Installation.....	29
Lighting Instructions.....	30
Wiring	31
Start Up Check List.....	31
Start Up and Adjustments.....	32-33
Remote Instructions.....	34-40
Troubleshooting	41
Automatic Humidifier Operation.....	42
Maintenance & Service.....	42-43
Decorative Glass and Rock Media Accessory Installation.....	44-45
Parts List.....	46
Parts View	47
Master Parts Distributor List	48
How To Order Repair Parts	48
Warranty Terms	49
Appliance Service History.....	50-51

IMPORTANT SAFETY INFORMATION

THIS IS A HEATING APPLIANCE

Safety markings are frequently used in this manual to designate a degree or level of seriousness and should not be ignored.

▲ WARNING indicates a potentially hazardous situation that if not avoided, could result in personal injury or death.

▲ CAUTION indicates a potentially hazardous situation that if not avoided, may result in minor or moderate injury or property damage.

▲ WARNING

This appliance must be installed and repaired by a qualified service person who is familiar with the proper installation and operation of the Mantis Power-Vent High Efficiency Fireplace. Installers who are not familiar with the installation of the Mantis and have questions, should contact Empire Comfort Systems, Inc. prior to installing the appliance to avoid creating a hazardous operating condition.

- Due to high temperatures the appliance should be located out of traffic and away from furniture and draperies.
- Children and adults should be alerted to the hazards of high surface temperatures and should stay away to avoid burns or clothing ignition.
- Young children should be carefully supervised when they are in the same room as the appliance. Toddlers, young children and others may be susceptible to accidental contact burns. A physical barrier is recommended if there are at risk individuals in the house. To restrict access to a fireplace or stove, install an adjustable safety gate to keep away toddlers, young children and other at risk individuals out of the room and away from hot surfaces.
- Clothing or other flammable material should not be placed on or near the appliance.
- Any safety screen or guard removed for servicing an appliance, must be replaced prior to operating the appliance.
- Keep burner and control compartment clean.
- For manufactured home (USA only) or mobile home or residential installation convertible for use with natural gas and liquefied petroleum gases when provision is made for the simple conversion from one gas to the other.
- Young children should be carefully supervised when they are in the same room as the appliance. Toddlers, young children, and others may be susceptible to accidental contact burns. A physical barrier is recommended if there are at-risk individuals in the house. To restrict access to a fireplace or stove, install an adjustable safety gate to keep toddlers young children, and other at-risk individuals out of the room and away from hot surfaces.
- A barrier designed to reduce the risk of burns from the hot viewing glass is provided with this appliance and shall be installed for the protection of children and other at-risk individuals.

- If the barrier becomes damaged, the barrier shall be replaced with the manufacturer's barrier for this appliance.
- Any safety screen, guard, or barrier removed for servicing an appliance must be replaced prior to operating the appliance.

▲ WARNING

Installation and repair should be done by a **QUALIFIED SERVICE PERSON**. The appliance should be inspected before use and at least annually by a qualified service person. More frequent cleaning may be required due to excessive lint from carpeting, bedding materials, etc. It is imperative that control compartments, burners and circulating air passageways of the appliance be kept clean.

- **DO NOT** put anything around the fireplace that will obstruct the flow of combustion and ventilation air.
- **DO** keep the appliance area clear and free from combustible material, gasoline and other flammable vapors and liquids.
- **Do** examine venting system periodically and replace damaged parts.
- **Do** make a periodic visual check of burner. Clean and replace damaged parts.
- **DO NOT** use this fireplace if any part has been under water. Immediately call a qualified service technician to inspect the fireplace and to replace any part of the control system and any gas control which has been under water.
- **DO NOT** operate this appliance without the front panel installed.

Note to the Installer

1. The installer must leave instruction manual with owner after installation.
2. The installer must have the owner fill out and mail registration card supplied with the fireplace.
3. The installer should show the owner how to start and operate fireplace and thermostat.
4. The installer must locate fireplace near a grounded wall receptacle for 115VAC power and must provide gas supply and vent the fireplace properly for safe operation.

SAFETY INFORMATION FOR USERS OF LP-GAS

LP-Gas (Propane) is a flammable gas which can cause fires and explosions. In its natural state, propane is odorless and colorless. You may not know all the following safety precautions which can protect both you and your family from an accident. Read them carefully now, then review them point by point with the members

of your household. Someday, there may not be a minute to lose, everyone's safety will depend on knowing exactly what to do. If, after reading the following information, you feel you still need more information, please contact your gas supplier.

LP-GAS WARNING ODOR

If a gas leak happens, you should be able to smell the gas because of the odorant put in the LP-Gas. That's your signal to go into immediate action!

- Do not operate electric switches, light matches, use your phone. Do not do anything that could ignite the gas.
- Get everyone out of the building, vehicle, trailer, or area. Do that IMMEDIATELY.
- Close all gas tank or cylinder supply valves.
- LP-Gas is heavier than air and may settle in low areas such as basements. When you have reason to suspect a gas leak, keep out of basements and other low areas. Stay out until firefighters declare them to be safe.
- Use your neighbor's phone and call a trained LP-Gas service person and the fire department. Even though you may not continue to smell gas, do not turn on the gas again. Do not re-enter the building, vehicle, trailer, or area.
- Finally, let the service man and firefighters check for escaped gas. Have them air out the area before you return. Properly trained LP-Gas service people should repair the leak, then check and relight the gas appliance for you.

NO ODOR DETECTED - ODOR FADE

Some people cannot smell well. Some people cannot smell the odor of the chemical put into the gas. You must find out if you can smell the odorant in propane. Smoking can decrease your ability to smell. Being around an odor for a time can affect your sensitivity or ability to detect that odor. Sometimes other odors in the area mask the gas odor. People may not smell the gas odor or their minds are on something else. Thinking about smelling a gas odor can make it easier to smell.

The odorant in LP-gas is colorless, and it can fade under some circumstances. For example, if there is an underground leak, the movement of the gas through soil can filter the odorant. Odorants in LP-Gas also are subject to oxidation. This fading can occur if

there is rust inside the storage tank or in iron gas pipes.

The odorant in escaped gas can adsorb or absorb onto or into walls, masonry and other materials and fabrics in a room. That will take some of the odorant out of the gas, reducing its odor intensity.

LP-Gas may stratify in a closed area, and the odor intensity could vary at different levels. Since it is heavier than air, there may be more odor at lower levels. Always be sensitive to the slightest gas odor. If you detect any odor, treat it as a serious leak. Immediately go into action as instructed earlier.

SOME POINTS TO REMEMBER

- Learn to recognize the odor of LP-gas. Your local LP-Gas Dealer can give you a "Scratch and Sniff" pamphlet. Use it to find out what the propane odor smells like. If you suspect that your LP-Gas has a weak or abnormal odor, call your LP-Gas Dealer.
- If you are not qualified, do not light pilot lights, perform service, or make adjustments to appliances on the LP-Gas system. If you are qualified, consciously think about the odor of LP-Gas prior to and while lighting pilot lights or performing service or making adjustments.
- Sometimes a basement or a closed-up house has a musty smell that can cover up the LP-Gas odor. Do not try to light pilot lights, perform service, or make adjustments in an area where the conditions are such that you may not detect the odor if there has been a leak of LP-Gas.
- Odor fade, due to oxidation by rust or adsorption on walls of new cylinders and tanks, is possible. Therefore, people should be particularly alert and careful when new tanks or cylinders are placed in service. Odor fade can occur in new tanks, or reinstalled old tanks, if they are filled and allowed to set too long before refilling. Cylinders and tanks which have been out of service for a time may develop internal rust which will cause odor fade. If such conditions are suspected to exist, a periodic sniff test of the gas is advisable. If you have any question about the gas odor, call your LP-gas dealer. A periodic sniff test of the LP-gas is a good safety measure under any condition.
- If, at any time, you do not smell the LP-Gas odorant and you think you should, assume you have a leak. Then take the same immediate action recommended above for the occasion when you do detect the odorized LP-Gas.
- If you experience a complete "gas out," (the container is under no vapor pressure), turn the tank valve off immediately. If the container valve is left on, the container may draw in some air through openings such as pilot light orifices. If this occurs, some new internal rusting could occur. If the valve is left open, then treat the container as a new tank. Always be sure your container is under vapor pressure by turning it off at the container before it goes completely empty or having it refilled before it is completely empty.

REQUIREMENTS FOR MASSACHUSETTS

For all side wall horizontally vented gas fueled equipment installed in every dwelling, building or structure used in whole or in part for residential purposes, including those owned or operated by the Commonwealth and where the side wall exhaust vent termination is less than seven (7) feet above finished grade in the area of the venting, including but not limited to decks and porches, the following requirements shall be satisfied:

1. INSTALLATION OF CARBON MONOXIDE DETECTORS.

At the time of installation of the side wall horizontal vented gas fueled equipment, the installing plumber or gasfitter shall observe that a hard wired carbon monoxide detector with an alarm and battery back-up is installed on the floor level where the gas equipment is to be installed. In addition, the installing plumber or gasfitter shall observe that a battery operated or hard wired carbon monoxide detector with an alarm is installed on each additional level of the dwelling, building or structure served by the side wall horizontal vented gas fueled equipment. It shall be the responsibility of the property owner to secure the services of qualified licensed professionals for the installation of hard wired carbon monoxide detectors

- a. In the event that the side wall horizontally vented gas fueled equipment is installed in a crawl space or an attic, the hard wired carbon monoxide detector with alarm and battery back-up may be installed on the next adjacent floor level.
- b. In the event that the requirements of this subdivision can not be met at the time of completion of installation, the owner shall have a period of thirty days to comply with the above requirements; provided, however, that during said thirty day period, a battery operated carbon monoxide detector with an alarm shall be installed.

2. APPROVED CARBON MONOXIDE DETECTORS. Each carbon monoxide detector as required in accordance with the above provisions shall comply with NFPA 720 and be ANSI/UL 2034 listed and IAS certified.

3. SIGNAGE. A metal or plastic identification plate shall be permanently mounted to the exterior of the building at a minimum height of eight feet above grade directly in line with the exhaust vent terminal for the horizontally vented gas fueled heating appliance or equipment. The sign shall read, in print size no less than one-half (1/2) inch in size, **"GAS VENT DIRECTLY BELOW. KEEP CLEAR OF ALL OBSTRUCTIONS"**.
4. INSPECTION. The state or local gas inspector of the side wall horizontally vented gas fueled equipment shall not approve the installation unless, upon inspection, the inspector observes carbon monoxide detectors and signage installed in accordance with the provisions of 248 CMR 5.08(2)(a) 1 through 4.
 - (b) EXEMPTIONS: The following equipment is exempt from 248 CMR 5.08(2)(a)1 through 4:
 1. The equipment listed in Chapter 10 entitled "Equipment Not Required To Be Vented" in the most current edition of NFPA 54 as adopted by the Board; and
 2. Product Approved side wall horizontally vented gas fueled equipment installed in a room or structure separate from the dwelling, building or structure used in whole or in part for residential purposes.
 - (d) MANUFACTURER REQUIREMENTS - GAS EQUIPMENT VENTING SYSTEM NOT PROVIDED. When the manufacturer of a Product Approved side wall horizontally vented gas fueled equipment does not provide the parts for venting the flue gases, but identifies "special venting systems", the following requirements shall be satisfied by the manufacturer:
 1. The referenced "special venting system" instructions shall be included with the appliance or equipment installation instructions; and
 2. The "special venting systems" shall be Product Approved by the Board, and the instructions for that system shall include a parts list and detailed installation instruction.
 - (e) A copy of all installation instructions for all Product Approved side wall horizontally vented gas fueled equipment, all venting instructions, all parts lists for venting instructions, and/or all venting design instructions shall remain with the appliance or equipment at the completion of the installation.

State of Massachusetts: The installation must be made by a licensed plumber or gas fitter in the Commonwealth of Massachusetts.

INTRODUCTION

WARNING

The safety information listed below must be followed during the installation, service, and operation of this product. Failure to following the safety recommendations could result in possible damage to the equipment, serious personal injury, or death.

Additional code information listed below is for reference purposes only and does not necessarily have jurisdiction over local or state codes. Always consult with local authorities before installing any gas appliance.

Combustion and Ventilation Air

U.S.: National Fuel Gas Code NFPA 54/ANSI Z223.1(NFGC), Air for Combustion and Ventilation.

Electrical Connections

U.S.: National Electrical Code (NEC) ANSI/NFPA 70

Gas Piping and Gas Pipe Pressure Testing

U.S.: NFGC and National Plumbing Codes

General Installations

U.S.: Current edition of the NFGC and NFPA 90B. For copies contact the National Fire Protection Association Inc., Batterymarch Park, Quincy, MA 02269 or American Gas Association, 400 N. Capitol, N.W., Washington DC 20001 or www.NFPA.org.

Safety

U.S.: NFGC NFPA 5/ANSI Z223.1

SPECIFICATIONS & ACCESSORIES

SPECIFICATIONS

Models	(F,I)G28BM(N,P)
Maximum Input BTU/HR (KW/H)	20,000 (5.86)
Minimum Input BTU/HR (KW/H)	10,000 (2.93)
Height	24-9/16"
Width	28"
Depth	17-3/16"
Gas Inlet (Pipe)	3/8" Flair
Electrical - The fireplace comes equipped with a 5 foot (1.5 m) 3 pronged cord, for connection to an approved 115 VAC, 60 Hz, 5A (maximum) wall receptacle.	
Vent Pipe: - 1-1/2 inch diameter schedule 40 PVC pipe, 40 feet maximum equivalent length with (3) 90° elbows.	

ACCESSORIES

Venting		Decorative Glass Kits (One kit per one square foot)	
Part Number	Description	Part Number	Description
PVVK-FC	Single Flue Horizontal Vent Kit	DG1BKP	Decorative Glass, Black Polished
PVCA	Colinear Adapter	DG1BUC	Decorative Glass, Blue Clear
PVCT	Colinear Transition Kit	DG1CLF	Decorative Glass, Clear Frosted
PVVK-CFA	Flex Vent Kit	DG1AB	Decorative Glass Droplets - 1/2" Aqua Blue
PVVK-SV	Single Flue Vertical Vent Kit	DG1GC	Decorative Glass Droplets - 1/2" Glacier Ice
PVVT	Vertical Termination Cap - 1-1/2"	DG1 SL	Decorative Glass Droplets - 1/2" Sangria Luster
PVVK24H	Coaxial Horizontal Direct Vent Kit (24")	DG1NXS	Decorative Glass Droplets - 1" Onyx Solid
PVVK48H	Coaxial Horizontal Direct Vent Kit (48")	DG1RYC	Decorative Glass Droplets - 1" Ruby Clear
Surrounds with Barriers		DG1TZ	Decorative Glass Droplets - 1" Topaz Clear
Part Number	Description	Decorative Rock Kits	
FWKQ28BL	In-Wall Surround Kit, Picture Frame with Barrier	Part Number	Description
FHKQ28BL	In-Wall Surround Kit, Louverless with Barrier	DRFPA	Decorative Rock - Small (One kit per 1/2 square foot)
FIKQ28BL	38" Wide X 30-7/8" Tall Insert Surround Kit with Barrier		
FFKQ28BL	35" Wide X 29-3/8" Tall Fireplace Mantel Surround Kit with Barrier		

Note: A barrier is required for operation of the appliance,

Note: The total burner cover area is two square feet.

Note: Never place media material on or next to the burner. See pages 44-45.

INSTALLATION AND GENERAL SAFETY INFORMATION

General Information

This series is designed certified in accordance with American National Standard/CSA Standard Z21.88 as a Gas Fireplace to be installed according to these instructions.

Any alteration of the original design, installed other than as shown in these instructions will be the responsibility of the person and company making the changes, and will void the warranty. This product may not be used with any type of gas other than what is shown on the rating plate.

Important

All Correspondence should refer to complete Model Number, Serial Number and type of gas.

Installation

Installation, replacement, gas piping, gas utilization equipment or accessories, and the repair and service of this equipment must be performed by a qualified agency. The term "qualified agency" means any individual, firm, corporation or company which either in person or through a representative is engaged in and is responsible for (a) the installation or replacement of gas piping or (b) the connection, installation, repair or servicing of equipment, who is experienced in such work, familiar with all precautions required and has complied with all the requirements of the authority having jurisdiction.

- This installation must conform with local codes, or in the absence of local codes, the National Fuel Gas Code, NFPA 54/ANSI Z223.1.
- This appliance, when installed, must be electrically grounded in accordance with local codes or. In the absence of local codes, with the National Electrical Code, ANSI/NFPA 70.
- Provide adequate clearances around the fireplace for servicing and ensure there are no obstructions to the combustion air intake situated at the back of the fireplace. Refer to Pages 24 to 28.
- The Mantis Power-Vent High-Efficiency Fireplace must be installed on a flat, solid continuous surface (i.e. wood, metal, concrete). Rough or uneven surfaces can cause vibration or humming in the fireplace.
- This appliance does need to be installed in such a way where the fireplace can be removed for servicing the heat exchanger and the flue that are located in the rear section of the fireplace.
- **This appliance is equipped with a three-prong [grounding] plug for your protection against shock hazard and should be plugged directly into a properly grounded three-prong receptacle. Do not cut or remove the grounding prong from this plug.** For an ungrounded receptacle, purchase an

adapter with two prongs and a wire for grounding.

Note: Under no circumstances should the appliance be installed under conditions that would not allow for easy removal of the appliance to carry out routine inspection and service to the appliance.

Note: Where a mantel surround is being used on insert installations and zero clearance fireplace installations, the combustion air intake slot located in the top mantel surround must not be obstructed. This will allow combustion air to enter through the slot to the combustion air inlet located at the back of the fireplace.

Note: During initial firing of this fireplace, residual oil from the heat exchanger may bake off and smoke may occur. Provide adequate ventilation to the area where the fireplace is installed to prevent triggering of smoke alarms. Refer to page 33 for more detail.

A manufactured home (USA only) or mobile home OEM installation must conform with the Manufactured Home Construction and Safety Standard, Title 24 CFR, Part 3280, or when such a standard is not applicable, the Standard for Manufactured Home Installations, ANSI/NCSBCS Z225.1, or Standard for Gas Equipped Recreational Vehicles and Mobile Housing, CSA Z240.0.

Installation on Combustible Flooring

If this appliance is to be installed directly on carpeting, tile, or other combustible material, other than wood flooring, the appliance shall be installed on a metal or wood panel extending the full width and depth of the appliance.

The base referred to above does not mean the fire-proof base as used on wood stoves. The protection is primarily for rugs that may be extremely thick and light-color tile that can discolor.

Installation in Residential Garages

Gas utilization equipment in residential garages shall be installed so that all burners and burner ignition devices are located not less than 18 inches (457 mm) above the floor. The equipment shall be located, or protected, so it is not subject to physical damage by vehicles.

Operation of Fireplace During Construction

The fireplace shall not be used during construction.

WARNING

Do not operate appliance with the glass front removed, or if it is cracked or broken. Replacement of the glass shall be performed by a licensed or qualified service person

GAS SUPPLY

All gas piping must be installed in compliance with local codes and utility regulations. In the absence of local codes the installation must comply with NFGC NFPA 54/ANSI Z223.1.

Note: Never use plastic pipe. Check to confirm whether your local codes allow copper tubing or galvanized.

Where permitted, flexible gas connectors must be certified to the following standards:

- ANS Z21.24 Appliance Connectors of Corrugated Metal Tubing and Fittings
- ANS Z21.45 Assembled Flexible Appliance Connectors of Other Than All-Metal Construction

The above connectors may be used if acceptable by the authority having jurisdiction. The state of Massachusetts requires that a flexible appliance connector cannot exceed three feet in length.

A drip leg should be installed in the vertical gas supply pipe run to the fireplace.

Manual Shut-off Valve

Some local regulations require the installation of a manual shut-off valve and ground joint union external to the appliance. The shut-off should be accessible for service and/or emergency use. Consult the local utility or gas supplier for additional requirements regarding the placement of the manual shut off valve. Compounds used on threaded joints of gas piping shall be resistant to the action of liquefied petroleum gases.

Leak Testing

⚠ WARNING - FIRE OR EXPLOSION HAZARD

Never test for leaks with an open flame. Check all connections using a commercially available soap solution. A fire or explosion may result causing property damage, personal injury or loss of life. Failure to follow the safety warnings exactly could result in serious injury, death or property damage.

After gas piping to the fireplace is complete, all connections must be tested for gas leaks. This includes pipe connections at the main gas valve, emergency shutoff valve and flexible gas connectors (if applicable). The soap and water solution can be applied on each joint or union using a small paintbrush. If any bubbling is observed, the connection is not sealed adequately and must be retightened. Repeat the tightening and soap check process until the bubbling ceases.

Important Note:

When pressure testing the gas supply lines at pressures greater than ½ psig (14 in. w.c.), the gas supply piping system must be disconnected from the appliance to prevent damage to the gas control valve. If the test pressure is less than or equal to ½ psig (14 in. w.c.), close the manual shut-off valve.

Pressure Testing of the Gas Supply System

1. To check the inlet pressure to the gas valve, a 1/8 inch N.P.T. plugged tapping, accessible for test gauge connection, must be placed immediately upstream of the gas supply connection to the appliance.
2. The appliance and its individual shutoff valve must be disconnected from the gas supply piping system during any pressure testing of that system at test pressures in excess of 1/2 psig.
3. The appliance must be isolated from the gas supply piping system by closing its individual manual shutoff valve during any pressure testing of the gas supply piping system at test pressures equal to or less than 1/2 psig.

Recommended Gas Pipe Diameter

Pipe Length	Schedule 40 Pipe Inside Diameter In Inches		Tubing, Type L Outside Diameter In Inches	
	Nat.	L.P.	Nat.	L.P.
0-10 feet	1/2	3/8	1/2	3/8
10-40 feet	1/2	1/2	5/8	1/2
40-100 feet	1/2	1/2	3/4	1/2
100-150 feet	3/4	1/2	7/8	3/4

VENT CLEARANCES

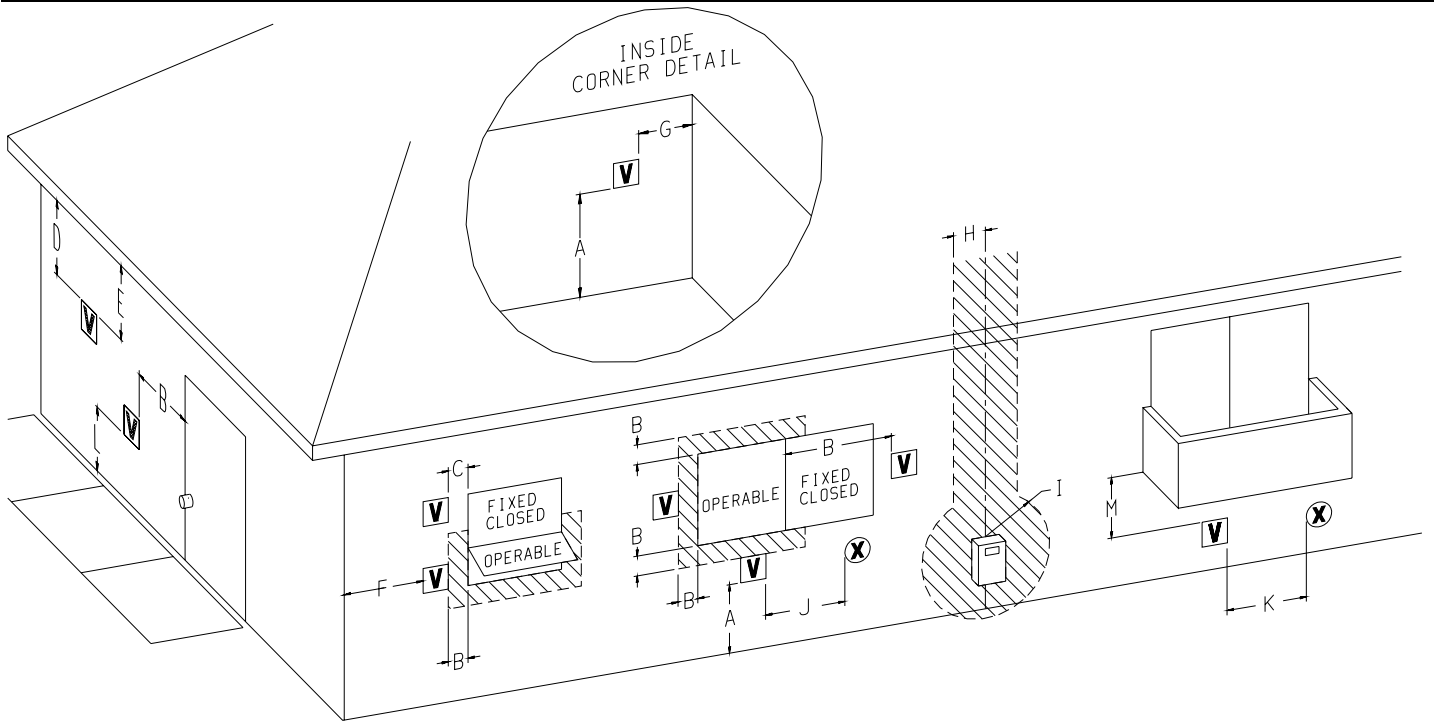

V VENT TERMINAL **X** AIR SUPPLY INLET [SHADDED] AREA WHERE TERMINAL IS NOT PERMITTED

Figure 1

US Installation ¹	
A =	Clearance above any grade, veranda, porch or balcony 12 in (30 cm)
B =	Clearance to window or door that may be opened 6 in (15 cm) for appliances ≤ 10,000 Btu/h (3 kW), 9 in (23 cm) for appliances > 10,000 Btu/h (3 kW) and ≤ 50,000 Btu/h (15 kW), 12 in (30 cm) for appliances > 50,000 Btu/h (15 kW)
C =	Clearance to permanently closed windows 0
D =	Vertical clearance to ventilated soffit located above the terminal within a horizontal distance of 2 ft (61 mm) from the center line of the terminal 18 in (46 cm)
E =	Clearance to unventilated soffit 18 in (46 cm)
F =	Clearance of outside corner 12 in (30 cm)
G =	Clearance of inside corner 12 in (30 cm)
H =	Clearance to each side of center line extended above meter/regulator assembly 6 ft (182 cm)
I =	Clearance to service regulator vent outlet 6 ft (182 cm)
J =	Clearance to non-mechanical air supply inlet to building or the combustion air inlet to any other appliance 6 in (15 cm) for appliances ≤ 10,000 Btu/h (3 kW), 9 in (23 cm) for appliances > 10,000 Btu/h (3 kW) and ≤ 50,000 Btu/h (15 kW), 12 in (30 cm) for appliances > 50,000 Btu/h (15 kW)
K =	Clearance to a mechanical air supply inlet 3 ft (91 cm) above if within 10 ft (3 m) horizontally
L =	Clearance above paved sidewalk or paved driveway located on public property † Not applicable
M =	Clearance under veranda, porch deck, or balcony ‡ 18 in (46 cm)
¹	In accordance with the current ANSI Z223.1/NFPA 54, National Fuel Gas Code
†	A vent shall not terminate directly above a sidewalk or paved driveway that is located between two single family dwellings and serves both dwellings.
‡	Permitted only if veranda, porch, deck or balcony is fully open on a minimum of two sides beneath the floor.
*	For clearances not specified in ANSI Z223.1/NFPA 54 or CSA B149.1, refer to local codes.

VENTING REQUIREMENTS

⚠ WARNING

This appliance must not be vented with any other appliances, even if that appliance is of the condensing type. Common venting can result in severe corrosion of other appliances or their venting and can allow combustion gases to escape through such appliances or vents. Do not vent the heater into a fireplace chimney or building chase.

⚠ WARNING

Upon completion of the installation, carefully inspect the entire flue system to assure it is properly sealed. DO NOT use any vent material other than what is specified in this manual. Leaks in the flue system can result in serious personal injury or death due to exposure of flue products, including carbon monoxide.

The Mantis is classified as a "Category IV" appliance, which requires special venting materials and installation procedures. Installations can be Conventional (one-pipe) and Direct Vent (two-pipe). Venting must be completed with 1-1/2 inch diameter pipe. In selecting a location for installation, it is necessary to provide adequate clearances for servicing and proper installation. All vent and combustion air pipes and fittings must be Schedule 40 PVC and meet the ANSI/ASTM Standard D1785. Cement must conform to ASTM Standard D2564.

Maximum Vent Length is 40 feet with three 90° elbows. The minimum vent length is twelve inches. Each 90° elbow used in the vent system will be the equivalent to three feet, and each 45° elbow is equivalent to 1.5 feet, which should be added to the overall vent length. See Table 1.

It is recommended that the Mantis Power-Vent High-Efficiency Fireplace be located on an exterior wall for ease of venting. The flue exhaust pipe and inlet air pipe should be located between wall studs. The required opening for venting is 1-7/8 inch in diameter for 1-1/2 inch PVC pipe.

For vent clearances refer to Figure 1 pg 10.

The bottom of the exhaust vent terminal and the air intake shall be located at least twelve inches above grade and must be vented outside. It is recommended the exhaust and intake be located twelve inches from the maximum snow level.

The flue pipe must be supported on horizontal vent runs. The flue pipe needs to be supported every three feet. All horizontal runs of the flue must be pitched 1/4 inch per foot either towards the fireplace or away from the fireplace.

Note: If the vent run dips or sags, condensation may become trapped and cause the unit to not operate properly.

The minimum vent length protruding from outside the wall is six inches. For two-pipe installation, a minimum distance of three inches and maximum distance of 24 inches must be maintained between the pipes. See Figures 2 and 3.

Single flue (one-pipe) installations must have a minimum clearance of two inches on the back of the fireplace for combustion air.

Note: If vent length requirements are not followed, the unit will not operate properly.

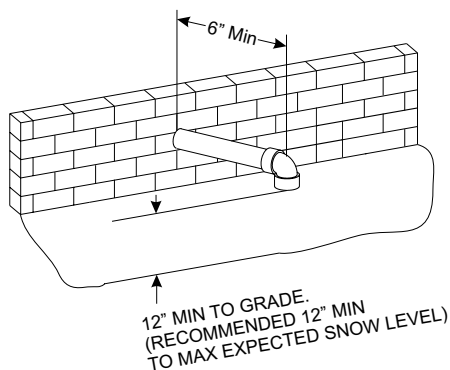

Figure 2 - Single Flue

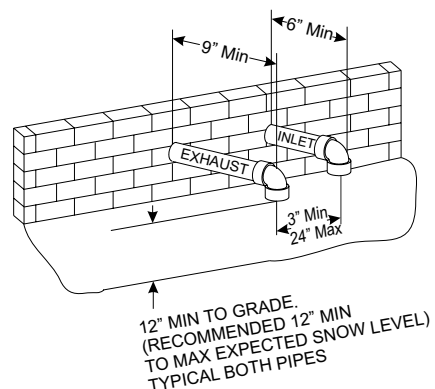

Figure 3 - Colinear Direct Vent

Table 1 - Equivalent Vent Length Example

EVL = Equivalent Vent Length

EVL must be greater than or equal to 1' and less than or equal to 40'

EVL =	90° elbow	+	4' straight pipe	+	45° elbow	+	2' straight pipe	+	45° elbow	+	3' straight pipe	=	15'
EVL =	3'	+	4'	+	1.5'	+	2'	+	1.5'	+	3'	=	15'
	(90° elbow)		(straight pipe)		(45° elbow)		(straight pipe)		(45° elbow)		(straight pipe)		

VENTING REQUIREMENTS

Vent Freezing Protection

When the vent pipe is exposed to temperatures below freezing (i.e. when it passes through unheated spaces, chimneys, etc.) The pipe must be insulated with 1/2 inch thick sponge rubber insulation, Armaflex-type insulation or equivalent. Insulating pipe is important to avoid condensate icing.

For proper operation, the flue exhaust must extend 6 inches from the outside wall before applying an elbow.

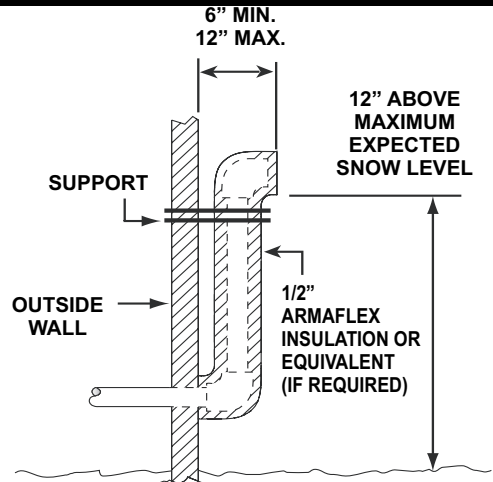

Figure 4

VENT ADAPTOR KITS

The Vent Adaptor Kits provide a transition from the appliance to the flue and inlet pipes. The Single Flue Horizontal Vent Kit (PVVK-FC) provides a transition for the piping. No cement is needed to attach the adaptor to the fireplace. When installing the

flue piping, use the appropriate primer and cement to permanently bond the joints and the pipes. Colinear Adaptor (part number PVCA) provides a transition for the inlet air piping. See page 16.

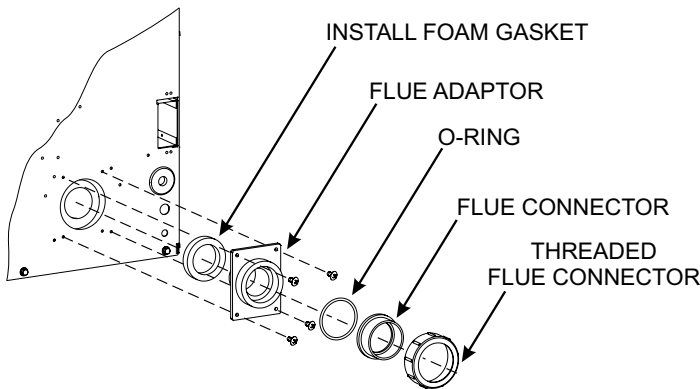

Figure 5

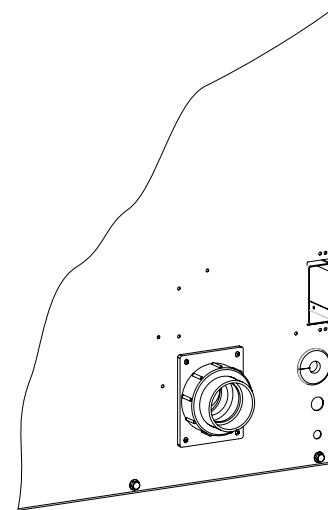
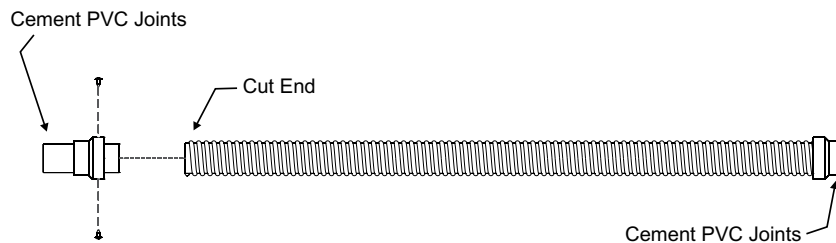

Figure 6

PVVK-CFA FLEX VENT KIT

Available from Empire Comfort Systems, Inc.

The PVVK-CFA flex vent kit is a flexible vent hose that is 42" in length. The flex vent kit will be used when installing a Mantis into an existing fireplace. The flex vent kit can be cut down, but can only be cut from one end.



Once length is determined, install two 10 x 1/2" screws into the adaptor assembly to secure the adaptor assembly to the flex hose. Using PVC cement, cement all PVC joints of the flex vent kit to the remaining PVC vent run.

PVVTTC TERMINATION CAP VENT KIT

Available from Empire Comfort Systems, Inc.

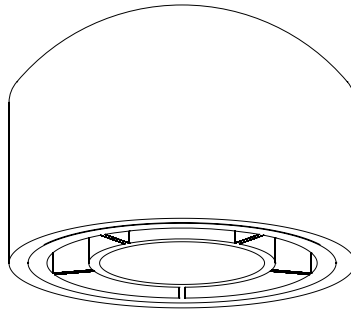

Termination Cap

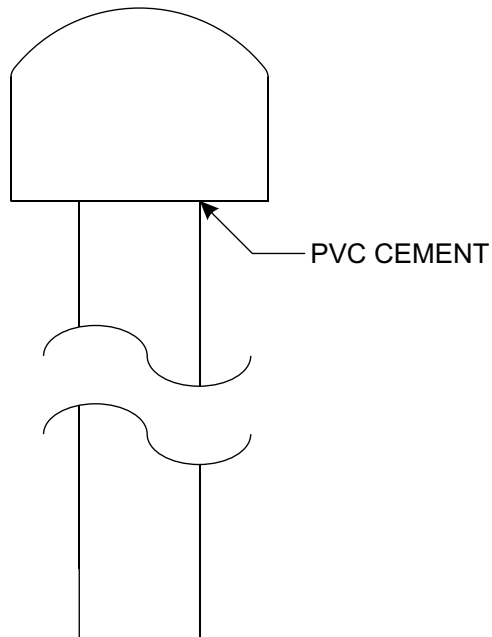

PVVTTC Vertical exhaust cap for use with 1 1/2" PVC pipe installation.
Termination cap also used with colinear transition plate model PVCT.
Refer to figures 10-15, 19 and 20 for venting examples.

VENT EXAMPLES FOR SINGLE FLUE

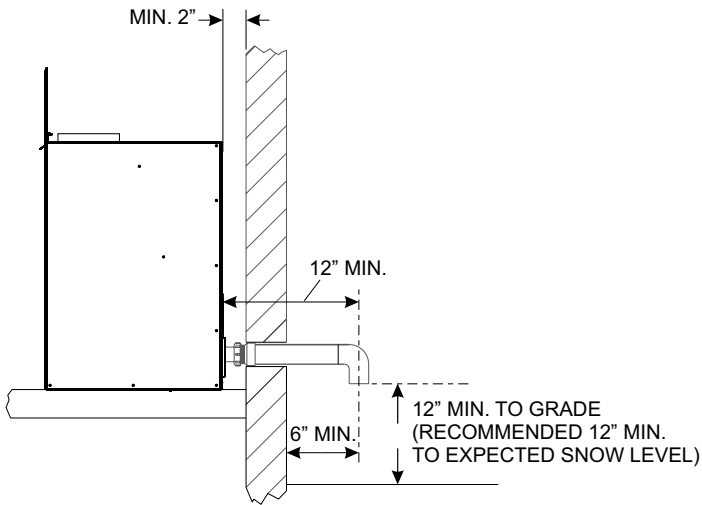

Figure 7
Single Flue - Straight Out Back
Min 6" Outside Wall
Min 2" From Fireplace to Wall for Intake Air
Min vent length 12"

Figure 8 displays a single flue (one-pipe) installation. Because the distance from the fireplace to the first elbow is more than six inches, the first 90° elbow must be considered into the total vent length. The equivalent length of the second 90° elbow also needs to be added to the total length, but the third elbow does not since it is the flue terminal. The total horizontal vent length of the flue system is seven feet, and the total vertical length is 27 feet. The two 90° elbows are equivalent to six feet, bringing the total to 40 feet.

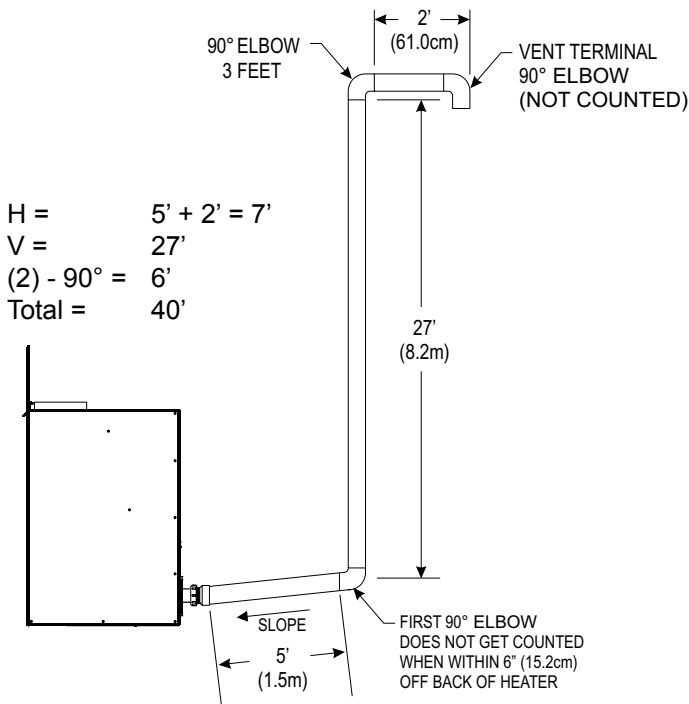

Figure 8
Single Flue - Horizontal Tall Vent Run
Example Calculation Max Vent Run 40 feet

$$\begin{aligned}
 H &= 5' + 2' = 7' \\
 V &= 27' \\
 (2) - 90^\circ &= 6' \\
 \text{Total} &= 40'
 \end{aligned}$$

$$\begin{aligned}
 H &= 1' \\
 V &= 36' \\
 (1) - 90^\circ &= 3' \\
 \text{Total} &= 40'
 \end{aligned}$$

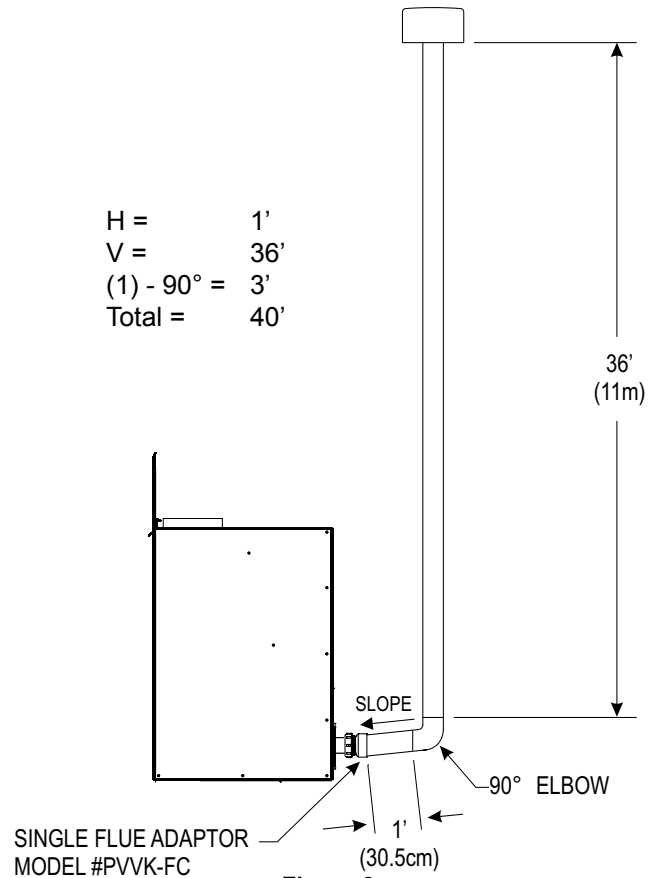

Figure 9
Single Flue - Vertical Vent Run

VENT EXAMPLES FOR SINGLE FLUE

Determining Minimum Vent Height Above the Roof

WARNING: Major U.S. building codes specify minimum chimney and/or vent height above the rooftop. These minimum heights are necessary in the interest of safety.

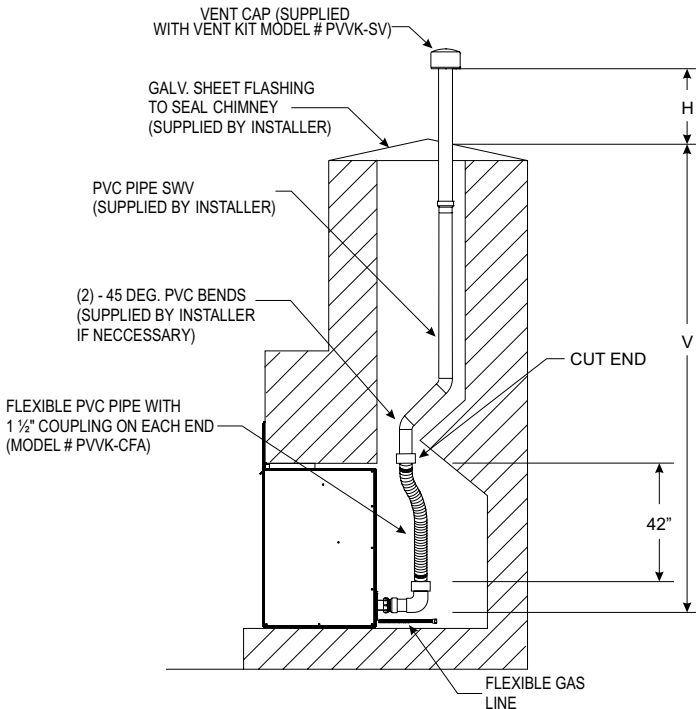
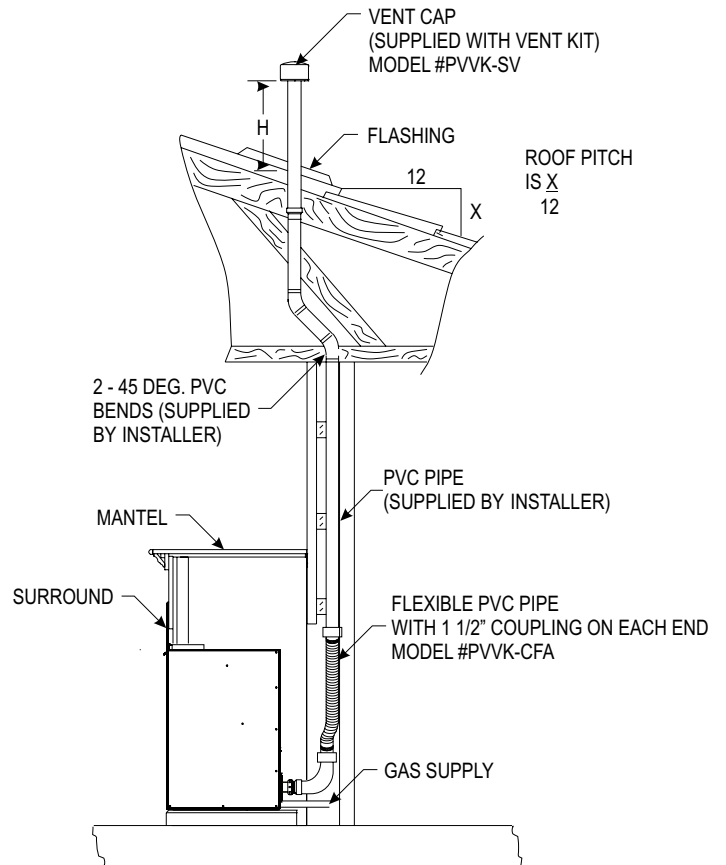

Figure 10 - Venting for Existing Fireplace Installation



Determining Minimum Vent Height Above the Roof

ROOF PITCH	H (Min.)
Flat to 6/12	12" (305 mm)
6/12 to 7/12	15" (381 mm)
Over 7/12 to 8/12	18" (457 mm)
Over 8/12 to 16/12	24" (610 mm)
Over 16/12 to 21/12	36" (914 mm)

Figure 11
Single Flue - Vertical Vent Run
with 45 degree elbows

WARNING: Major U.S. building codes specify minimum chimney and/or vent height above the rooftop. These minimum heights are necessary in the interest of safety. These specifications are summarized in Figure 11.

PVCA HORIZONTAL COLINEAR DIRECT VENT ADAPTOR

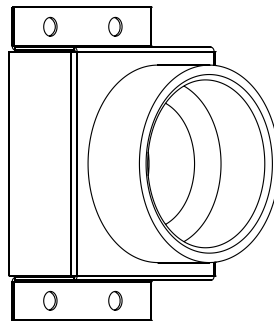

Colinear adaptor

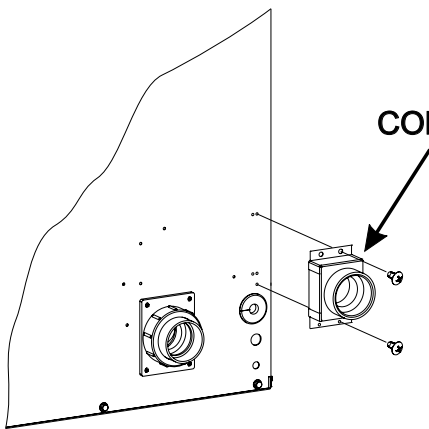

1. Attach colinear adaptor to back of fireplace with two screws.

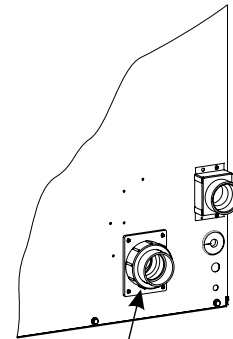

SINGLE FLUE HORIZONTAL ADAPTER MODEL PVVK-FC

2. When adapter is connected, continue with your vent run. Cementing PVC joint is recommended, but not required on colinear fresh air intake adaptor.

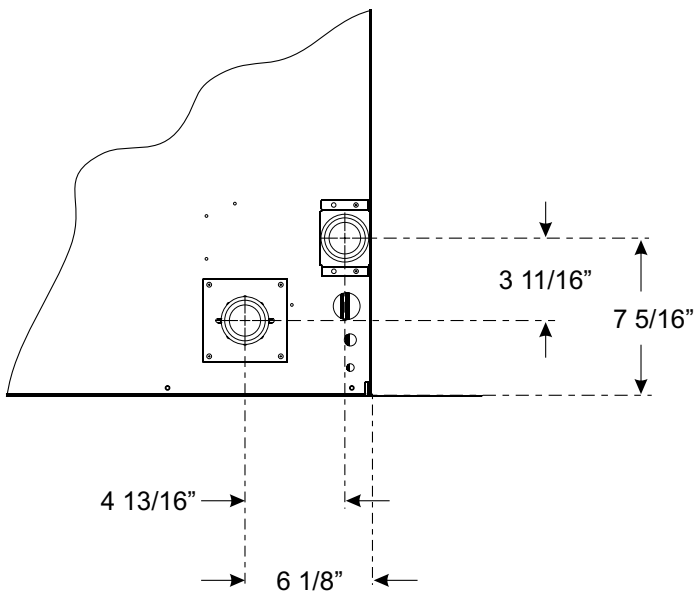

COLINEAR TRANSITION VENT KIT

Available from Empire Comfort Systems, Inc.

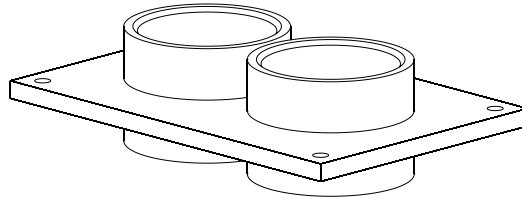

Colinear Transition Plate

The Colinear Transition Kit (Part number PVCT) is available and can be used to secure the flue and inlet pipes from the Mantis. When venting vertically, the exhaust pipe termination must be a minimum of 3 inches above the air inlet.

The flue can be terminated with a PTrap or two 90° elbows. The Vertical Termination Cap (Part number PVVTC) can also be used to terminate the flue pipe when using the Colinear Transition Kit.

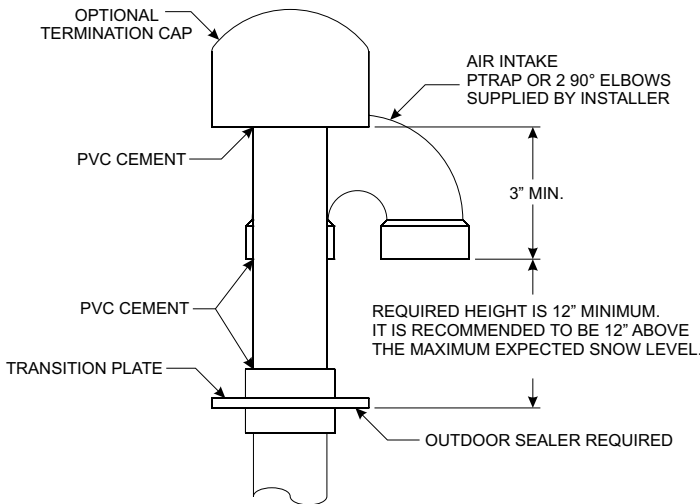

Figure 12

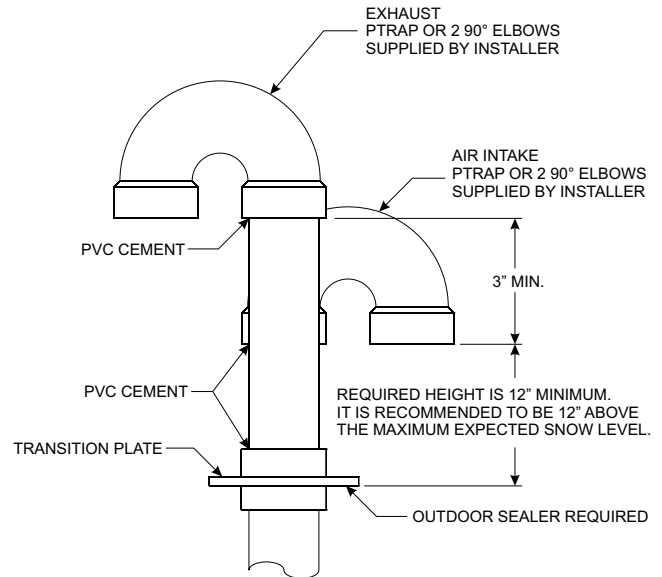
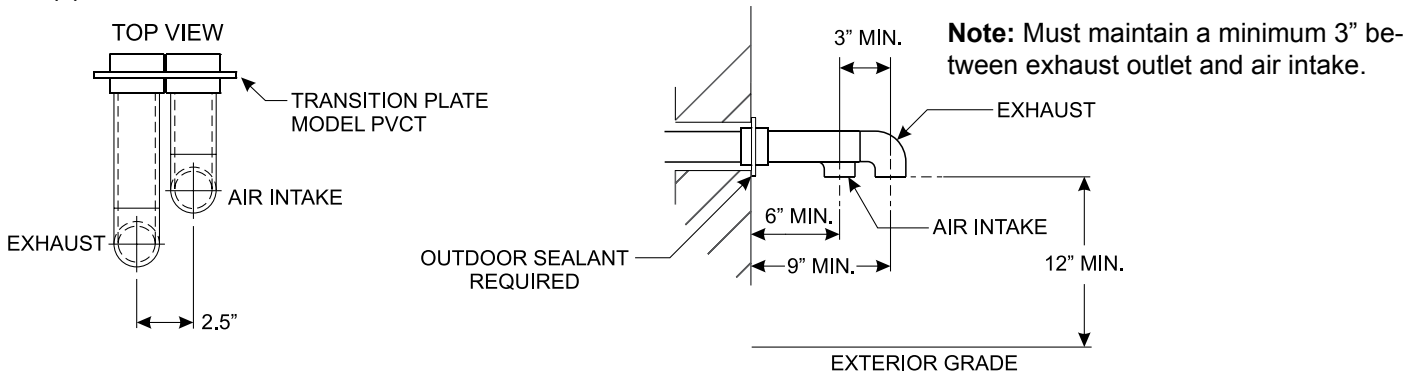

Figure 13

Installation of the Colinear Transition Plate

1. Attach the plate to chimney chase, flat roof, or outside wall with four screws. Use outdoor sealant to seal the transition plate to the surface.
2. Cut inlet air pipe and flue exhaust pipe to correct lengths. For vertical terminations through the roof or chimney, the air intake and exhaust pipe termination must be a minimum of twelve inches above the roof line. It is recommended that the air intake and exhaust pipe termination be twelve inches above the maximum expected snow level. See Figures 13 and 14. When venting vertically, the exhaust pipe termination must be a minimum of three inches above the air intake. Also refer to local codes. For horizontal termination through outside walls, the minimum pipe length is nine inches for exhaust pipe termination and six inches for the air intake.

3. Attach the flue and inlet air pipes to the transition plate. Use the appropriate primer and cement to permanently bond the joints and the pipes to the transition plate.



DIRECT VENT AND COLINEAR VENT EXAMPLES

Max Vent Run - 40 ft. Equivalent With Three 90° Elbows

Special Note: The vent terminal 90° elbow and first 90° elbow off back of the fireplace, when within six inches (15.2 cm), do not contribute to the overall vent length measurement. For each 45° elbow installed in the run, the length of the run MUST be reduced by 1.5 feet (45 cm). Reduce the length of the run three feet (91.4 cm) for every 90° elbow.

Note: Exhaust must be a minimum of 3 inches above air intake inlet.

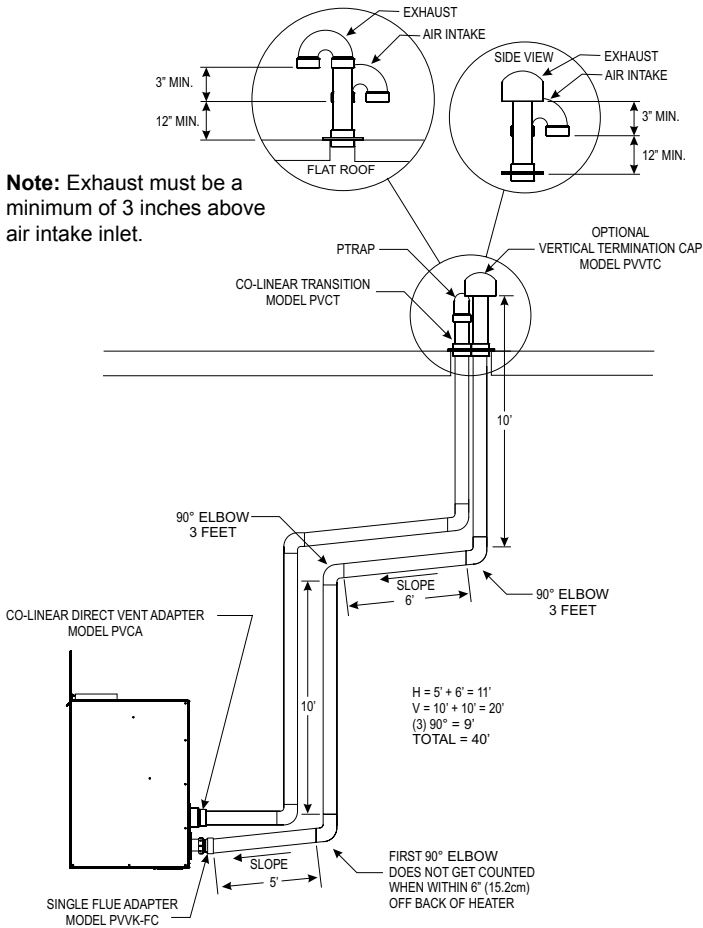

Figure 14

Calculation example of vent run maximum 40 feet

Figure 14 displays a two-pipe installation. Because the distance from the fireplace to the first elbow is more than six inches, the length allowance for the first 90° elbow must be added to the total vent length. The equivalent length of the second 90° elbow also needs to be added to the total length. The third elbow also needs to be included. The equivalent length of the PTrap does not need to be added since it is the termination. The total horizontal vent length of the flue system is eleven feet, and the total vertical length is 20 feet. The three 90° elbows are equivalent to nine feet, bringing the total to 40 feet.

Note: The exhaust must be a minimum of three inches above the inlet air pipe. The flue must be at least twelve inches from the roof line, and it is recommended to be at least twelve inches above the maximum expected snow level as indicated in Figures 13 through 20.

Note: On horizontal runs, a P.V.C. support clamp needs to be installed every three feet. No "sags" in horizontal vent runs; water will settle in the pipe.

When installing a colinear horizontal, the minimum vent length

protruding from the outside wall is six inches (15.2 cm) for air intake and nine inches for exhaust. See Figure 15.

Note: Horizontal discharge 90° elbow must be pointed downward. See Figure 15. All horizontal runs require either a 1/4" per foot rise to run condensation back to the fireplace, or a 1/4" per foot downward slope to run condensation away from the fireplace.

Note: All PVC vent run piping can be purchased at a local hardware store. Schedule 40 PVC pipe should be used and cemented. PVCA Horizontal Colinear Direct Vent Adaptor, PVVTC Cap, PVVK-CFA Flex Kit and PVVK-SH Horizontal Vent Adaptor Kit are available from Empire Comfort Systems, Inc.

In both vertical and horizontal colinear direct vent applications, a colinear transition plate model PVCT can be used to minimize clearances between intake and exhaust pipes.

For horizontal colinear direct venting, exhaust and intake air, cap pipes with 90° elbows, pointed downward.

Note: If transition plate (model PVCT) is used, the measurement for center to center of the pipes will be 2.5". If the transition plate (model PVCT) is not used, the measurement for center to center of the pipes can be 3" to 24" maximum.

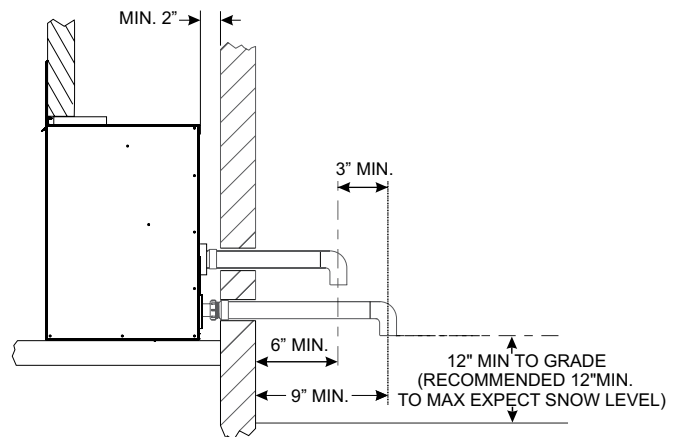

Figure 15

DIRECT VENT AND COLINEAR VENT EXAMPLES

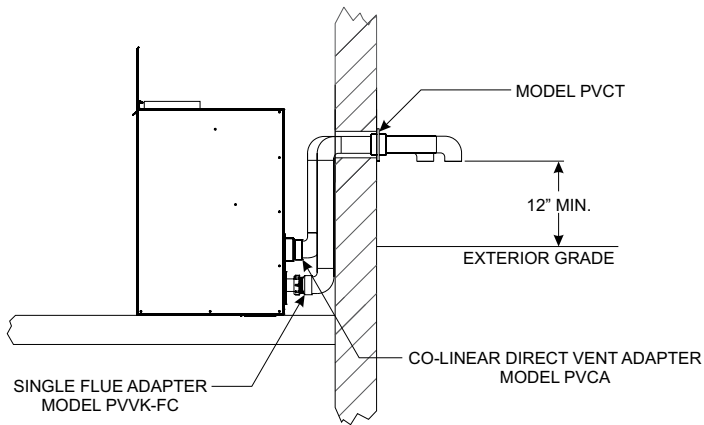

Figure 16

In direct vent applications, the minimum distance between the two pipes is three inches and the maximum distance is 24 inches. The flue exhaust and air inlet can be terminated with either a PTrap or two 90° elbows as shown in Figures 12, 13 and 14. The Vertical Termination Cap shown on page 13 (Part number PVVTC) can also be used.

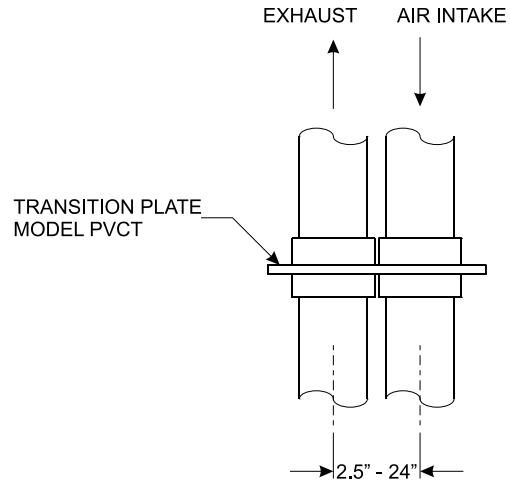

Figure 17

In both vertical and horizontal colinear direct vent applications, a colinear transition plate model PVCT can be used to minimize clearances between intake and exhaust pipes.

For exhaust and intake air, cap pipes with any of the following: Vertical termination cap (model #PVVTC), PTrap, or two 90° elbows. When transition plate (model PVCT) is used, two termination caps (model PVVTC) may NOT be used.

Note: If transition plate (model PVCT) is used, the measurement for center to center of the pipes will be 2.5". If the transition plate (model PVCT) is not used, the measurement for center to center of the pipes can be 3" to 24" maximum.

DIRECT VENT AND COLINEAR VENT EXAMPLES

Note: Exhaust must be a minimum of 3" above air intake inlet.

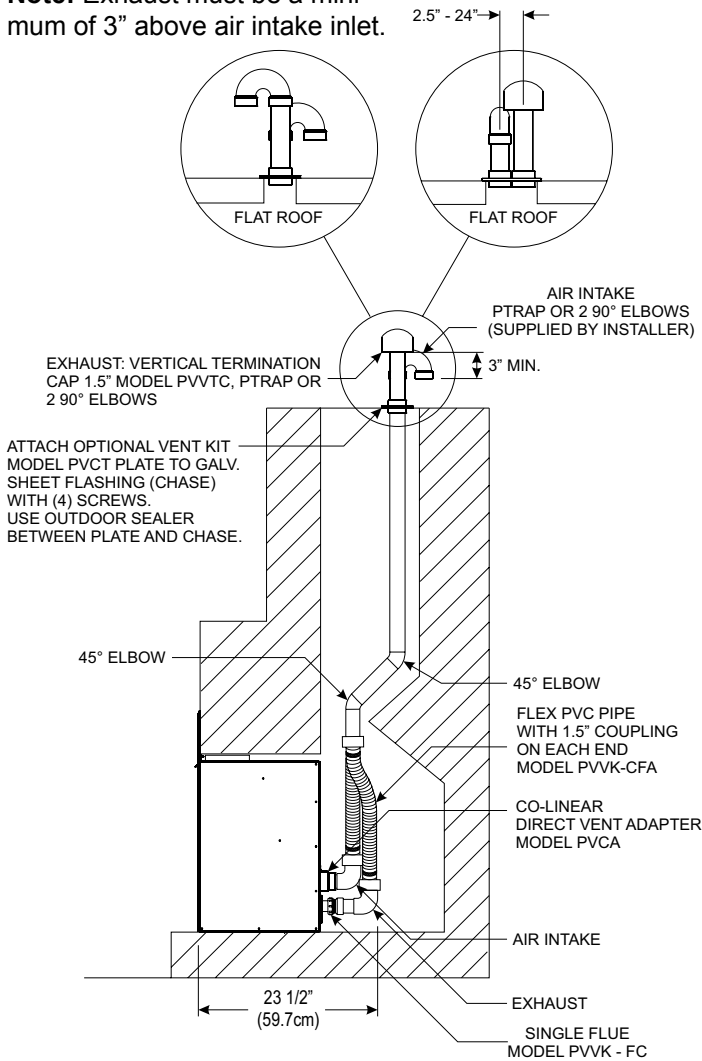

**Colinear Direct Vent - Insert Installation
Figure 18**

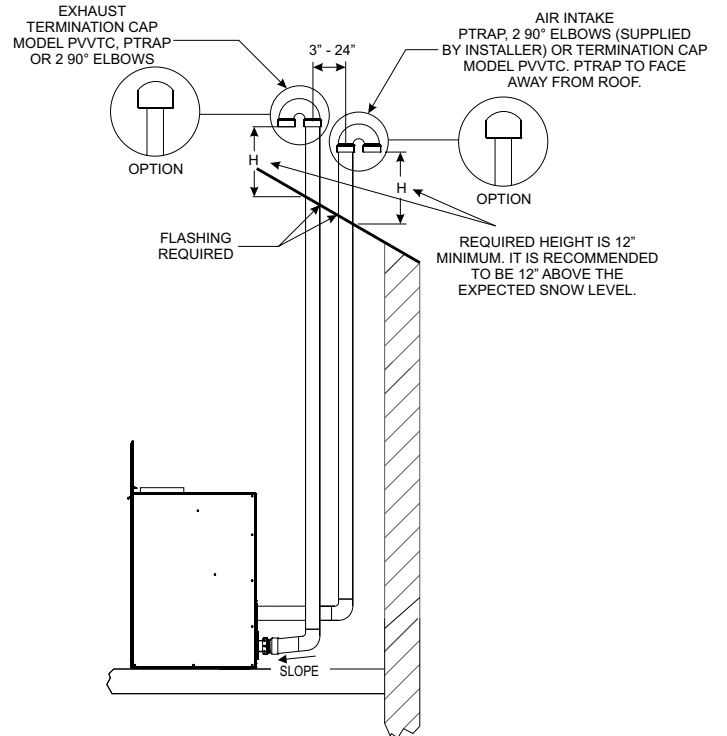

Determining Minimum Vent Height Above the Roof

ROOF PITCH	H (Min.)
Flat to 6/12	12" (305 mm)
6/12 to 7/12	15" (381 mm)
Over 7/12 to 8/12	18" (457 mm)
Over 8/12 to 16/12	24" (610 mm)
Over 16/12 to 21/12	36" (914 mm)

**Colinear Direct Vent - Pitched Roof Installation
Figure 19**

WARNING: Major U.S. building codes specify minimum chimney and/or vent height above the rooftop. These minimum heights are necessary in the interest of safety. These specifications are summarized in Figure 19.

PVK-24H AND PVK-48H CO-AXIAL VENT KIT

Available from Empire Comfort Systems, Inc.

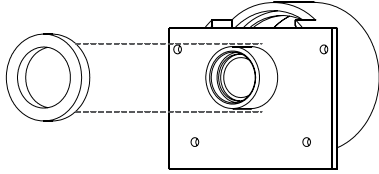

Step 1. Install foam gasket on back side of co-axial direct vent adaptor.

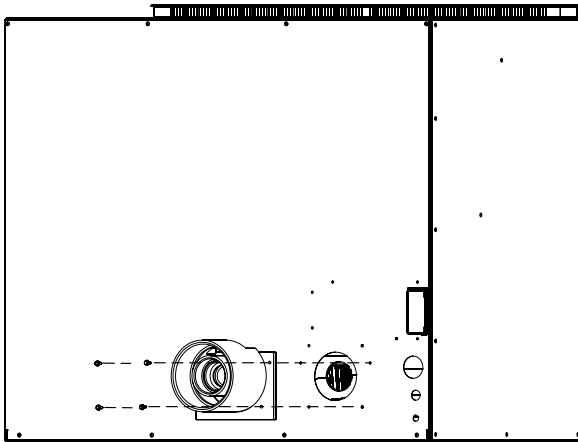

Step 2. Attach co-axial direct vent adaptor and gasket (4 screws) to the rear of fireplace.

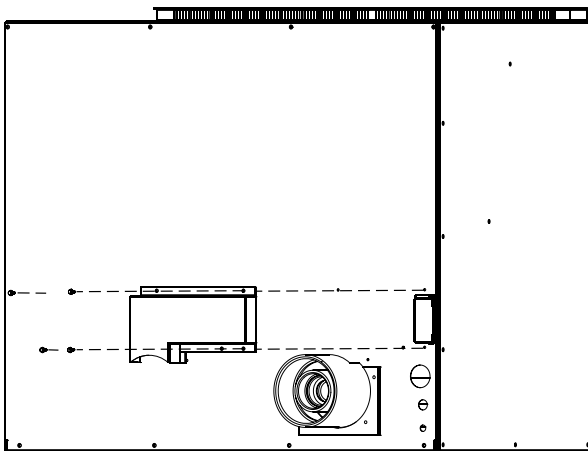

Step 3. Attach co-axial air-inlet duct to rear of fireplace (six screws).

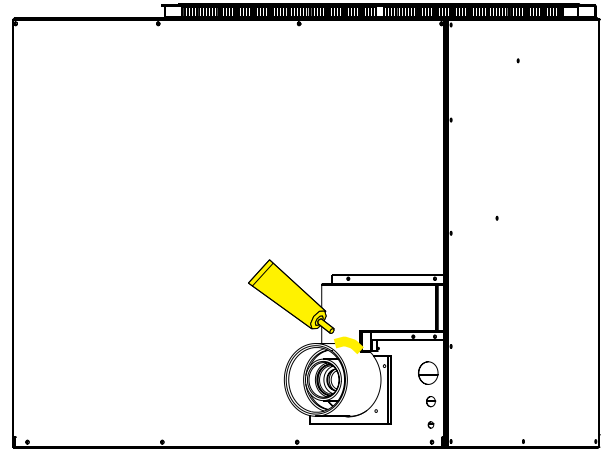

Step 4. Install silicone around connection between co-axial adaptor and co-axial air-inlet duct.

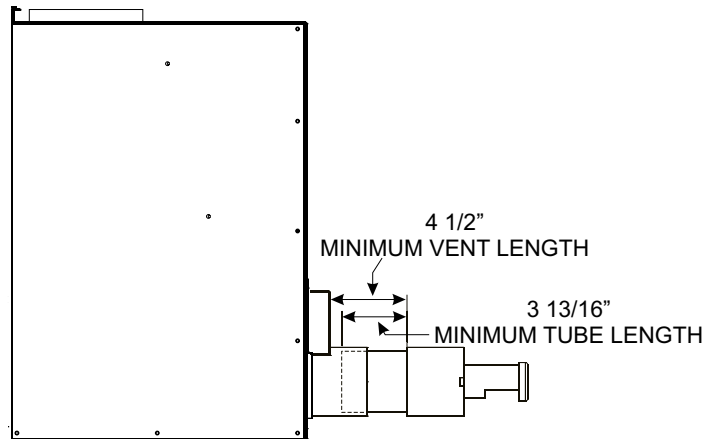

Step 5. Slide co-axial vent pipes into co-axial adaptor. Cut the PVC co-axial pipes at this time.
Minimum horizontal vent length 4 1/2" (11.4 cm)
Minimum tube length 3 13/16" (9.7 cm)

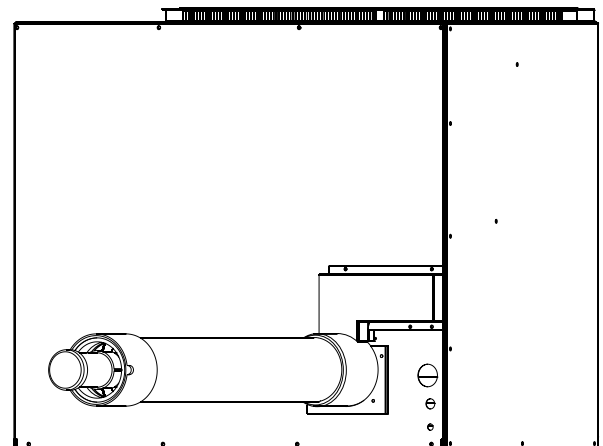

Step 6. Direct vent co-axial venting is completed.

PVK-24H AND PVK-48H CO-AXIAL VENT KIT (cont.)

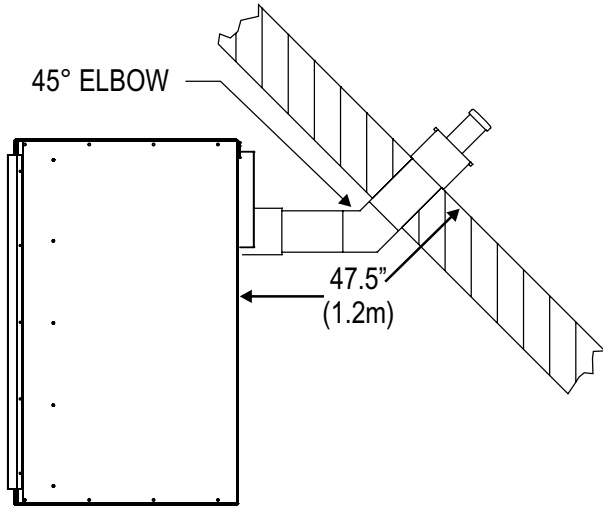

Horizontal Venting Maximum 47.5" (1.2 m) with 45° elbows. Inner 1-1/2 inch pipe and outer three inch pipe 45° elbows can be purchased from a local hardware store.

Figure 20

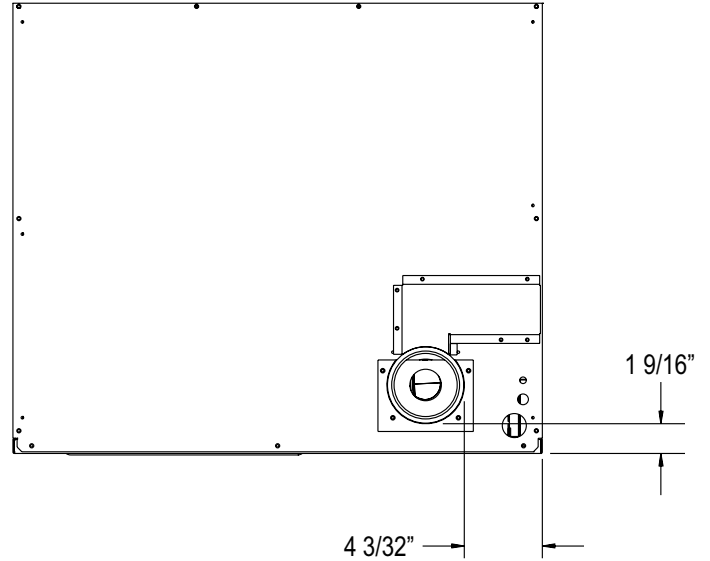
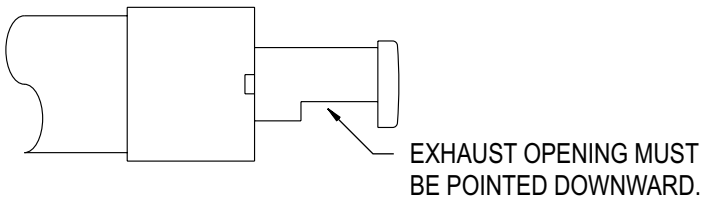
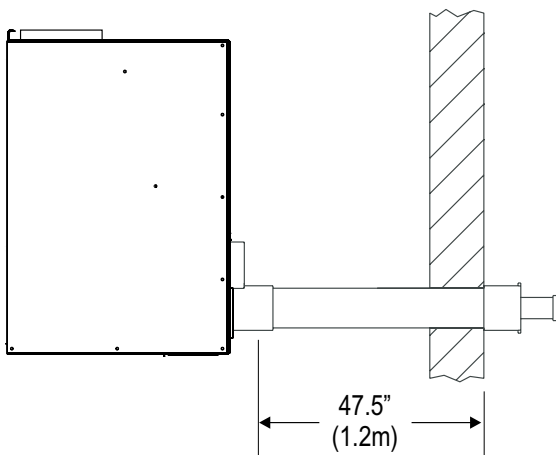

Figure 23



Direct Vent System Building Exterior View

Figure 21



Maximum Horizontal Venting - 47 1/2" (1.2 m)
Minimum Horizontal Venting - 4" (10.2 cm)

Figure 22

PVK-24H AND PVVK-48H CO-AXIAL VENT KIT (cont.)

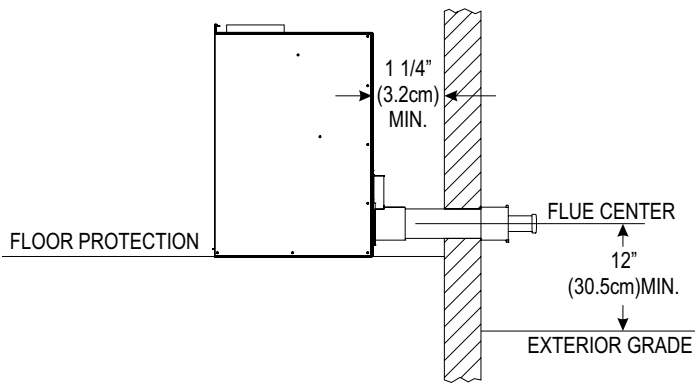

Figure 24
Minimum Exterior Grade Dimension

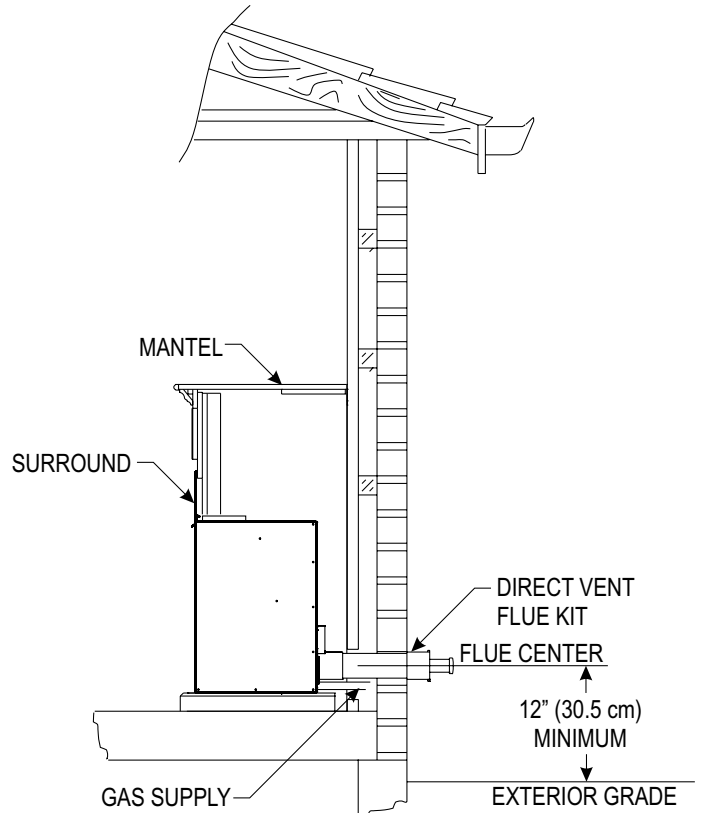

Figure 26
Horizontal Venting

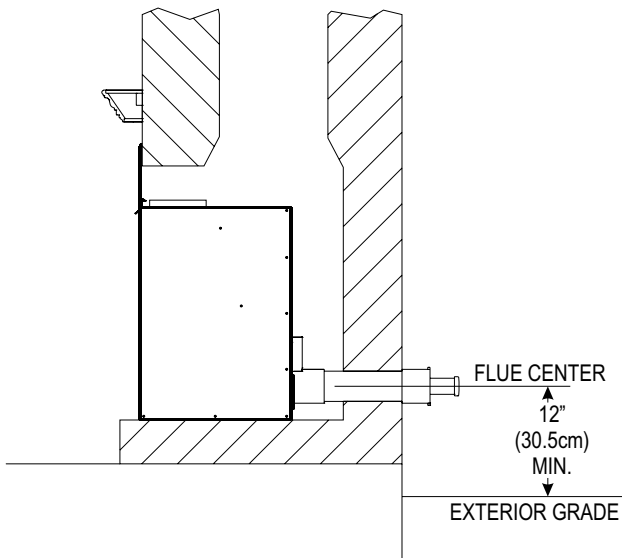

Figure 25
Minimum Exterior Grade Dimension - Existing Fireplace Installation

ROUGH FRAMING DIMENSIONS

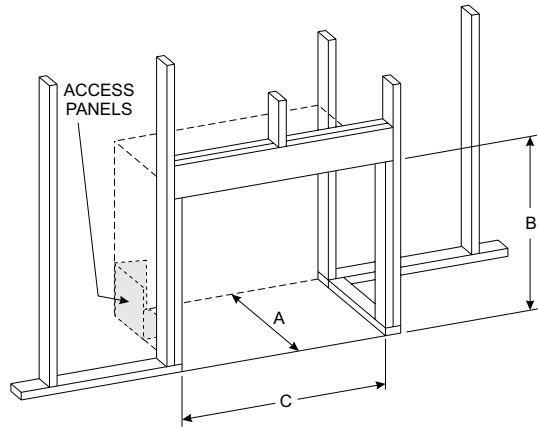

Figure 27

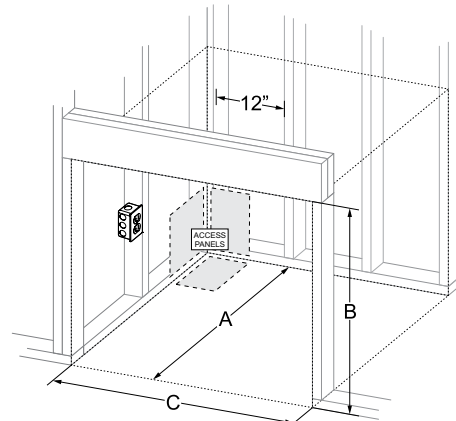

Figure 28

Index Letter	Single Vent	Direct Vent and Colinear Vent	Coaxial Vent	Flex Vent
A	19-1/2" minimum*	19-1/2" minimum*	18-1/2" minimum	23-3/4" minimum
B		25" minimum 27-3/4" maximum when using FHKQ28 Surround Kit 28-1/2" maximum when using FFKQ28 Surround Kit 29-1/2" maximum when using FIKQ28 Surround Kit 32" maximum when using FWKQ28 Surround Kit		
C		28-1/2" minimum, 31" recommended for service 33" maximum when using FHKQ28 Surround Kit 34" maximum when using FFKQ28 Surround Kit 37" maximum when using FIKQ28 Surround Kit 34" maximum when using FWKQ28 Surround Kit		

* When using a 2" radius 90° street ell on the flue exhaust, add 5-1/2".

INSERT INTO MASONRY FIREPLACE

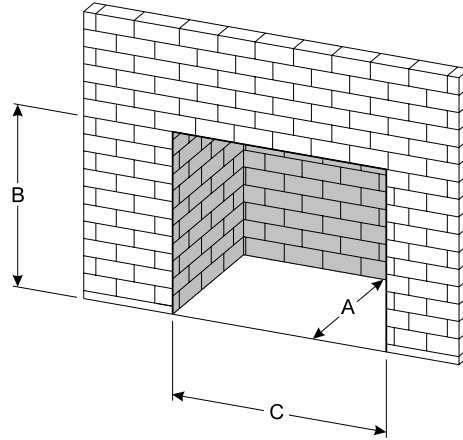

Figure 29

Index Letter	Single Vent	Direct Vent and Colinear Vent	Flex Vent
A	19-1/2" minimum*	19-1/2" minimum*	23-3/4" minimum
B	25" minimum 27-3/4" maximum when using FHKQ28 Surround Kit 28-1/2" maximum when using FFKQ28 Surround Kit 29-1/2" maximum when using FIKQ28 Surround Kit 32" maximum when using FWKQ28 Surround Kit		
C	28-1/2" minimum, 31" recommended for service 33" maximum when using FHKQ28 Surround Kit 34" maximum when using FFKQ28 Surround Kit 37" maximum when using FIKQ28 Surround Kit 34" maximum when using FWKQ28 Surround Kit		

* When using a 2" radius 90° street ell on the flue exhaust, add 5-1/2".

CLEARANCE TO COMBUSTIBLES

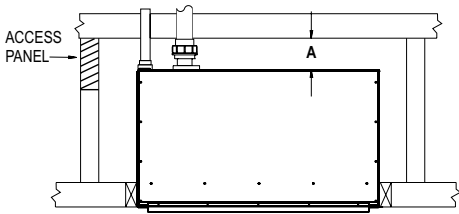

Figure 30

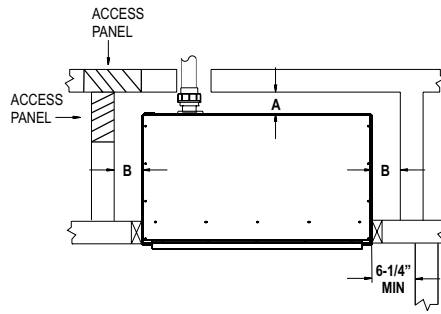

Figure 31

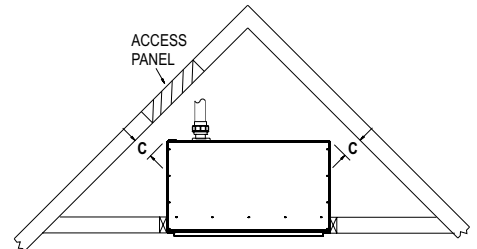
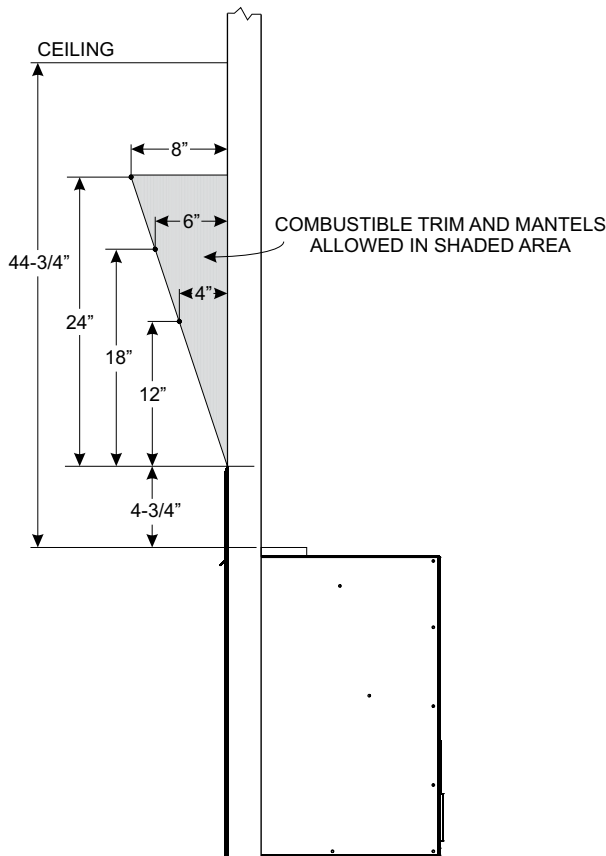

Figure 32

Insert Clearances		
A	Rear Wall to Fireplace	2" (1-1/4" for coaxial venting)
B	Side Wall to Fireplace	0"
C	Corner Installation	0"



Mantel and Ceiling Clearances
Figure 33

Note: The Mantis Power-Vent High-Efficiency Fireplace has been tested and approved for zero clearance to combustible materials. It is recommended that clearances as listed above should be maintained to allow for removal of the product for servicing.

SPECIFICATIONS

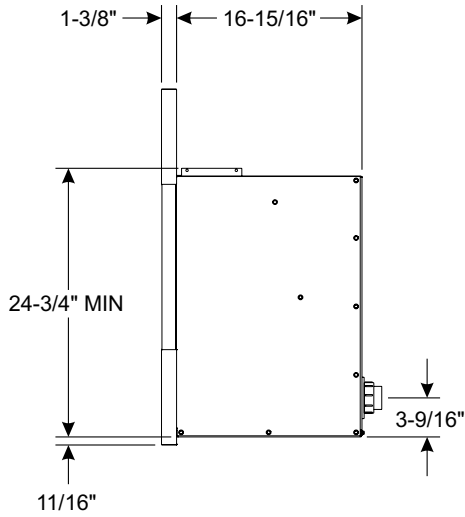

Figure 34

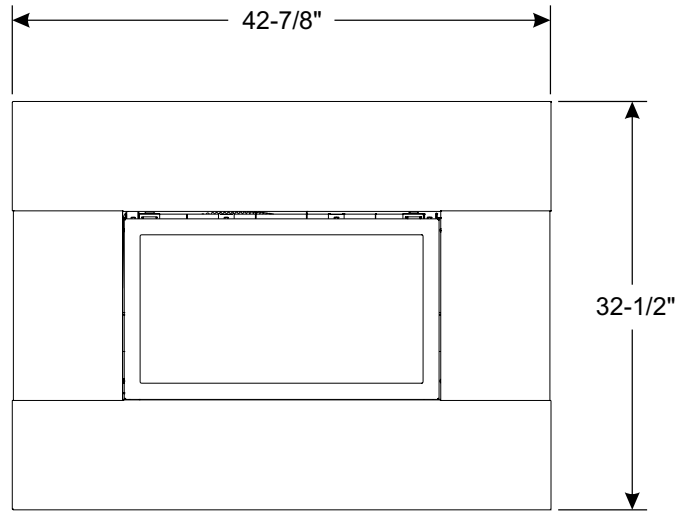

Figure 37

Fireplace - 42-7/8 inch Louverless Surround Kit
 FHKQ28(BL,SS) - Contains surround brackets and air deflector

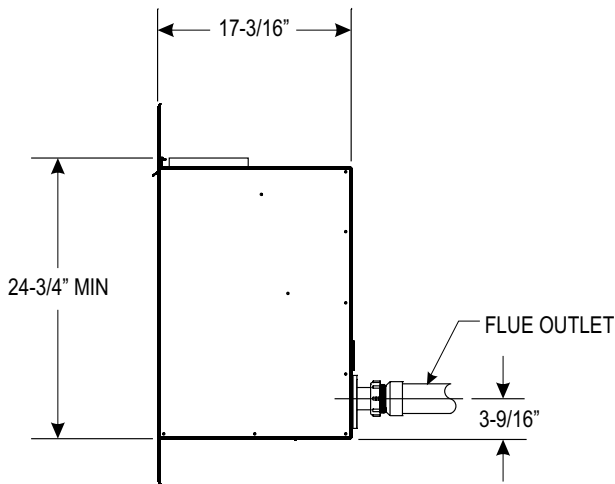

Figure 35

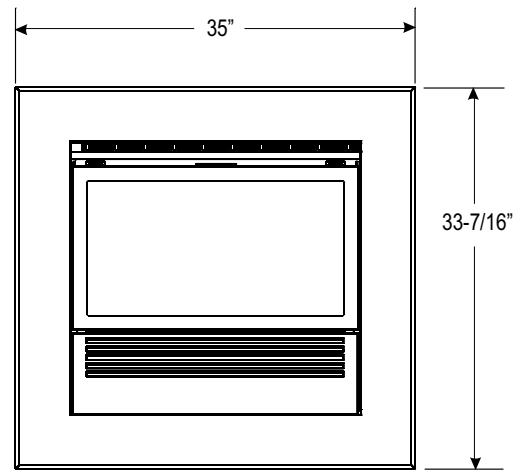

Figure 38

Fireplace In Wall - 35 Inch Picture Frame Surround
 FWKQ28(BL,CM,HP,SS) - Contains surround, hood, and lower front

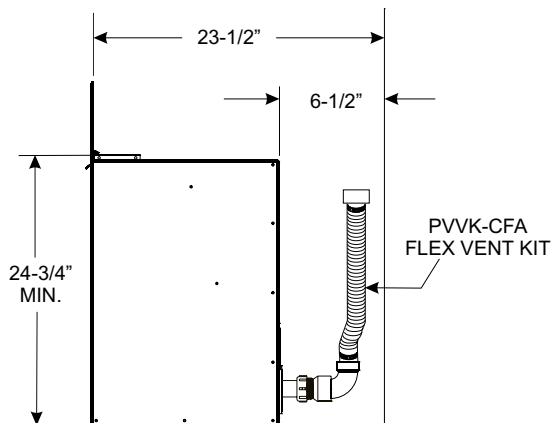

Figure 36

Fireplace with Flex Vent

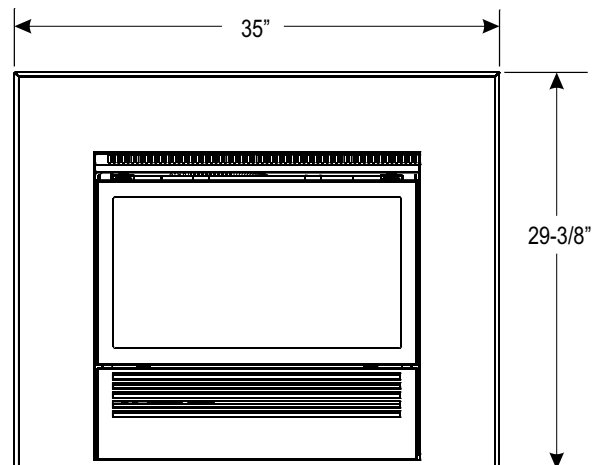

Figure 39

Fireplace - 35 Inch Surround Kit
 FFKQ28(BL,CM,HP,SS) - Contains surround, hood, & lower front

SPECIFICATIONS

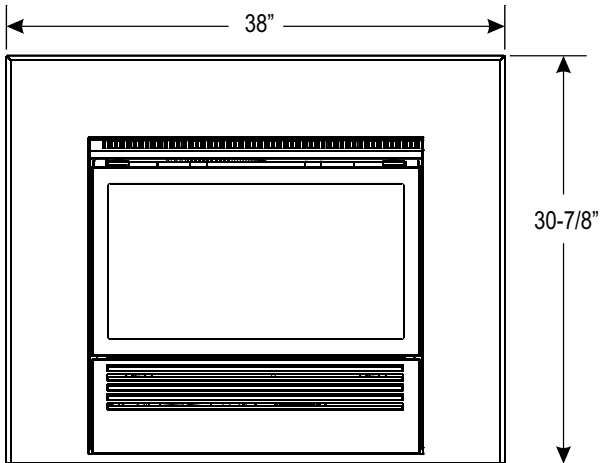

Figure 40
Fireplace - 38 Inch Surround
 FIKQ28(BL,CM,HP,SS) - Contains surround, hood, & lower front

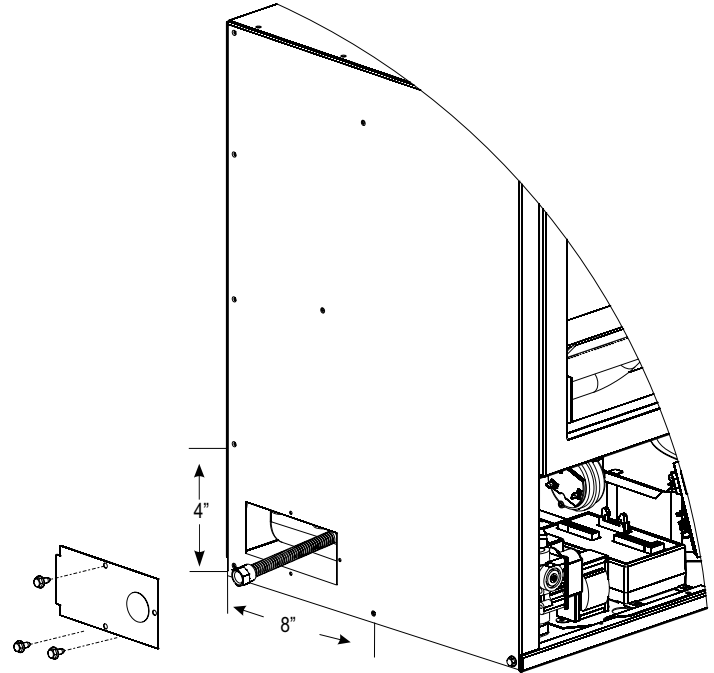

Figure 42
Clearance for Access Panel In-Wall Fireplace
 See Gas Connection Instructions.

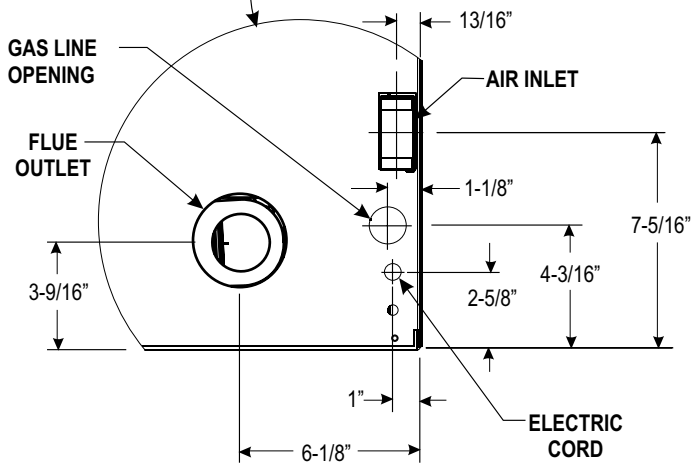
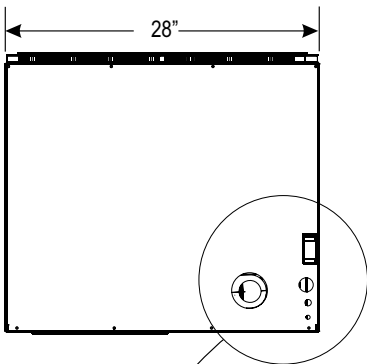

Figure 41

GAS CONNECTION INSTALLATION

⚠ CAUTION

The gas supply line to the heater must be installed under conditions which will allow for easy removal of the heater from its location for servicing of the heater. For fireplace insert installation, incorporate a loop into the flexible gas line.

Under no circumstances should the gas supply line to the appliance be installed in a way that would prevent the appliance from being serviced or inspected.

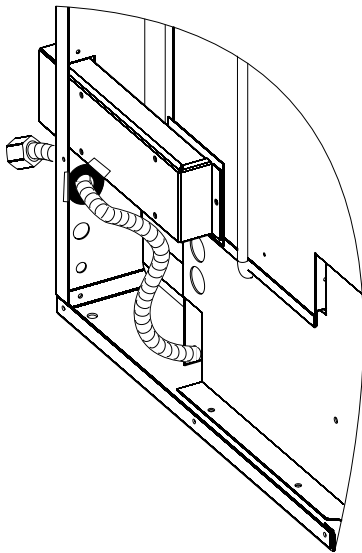

Figure 43- Fireplace Mantis

GAS SUPPLY LINE TO FIREPLACE

1. Pull the factory installed flexible gas line through the hole in the back panel. See Figures 43 and 44.
2. Connect the gas supply line to flexible gas hose. Ensure that flexible gas hose is not kinked after fitting gas supply line. Any excess flexible line can be pushed back into the fireplace.
3. Place rubber grommet that is supplied in hardware packet over the flexible gas line and secure in the hole in the back of the appliance.

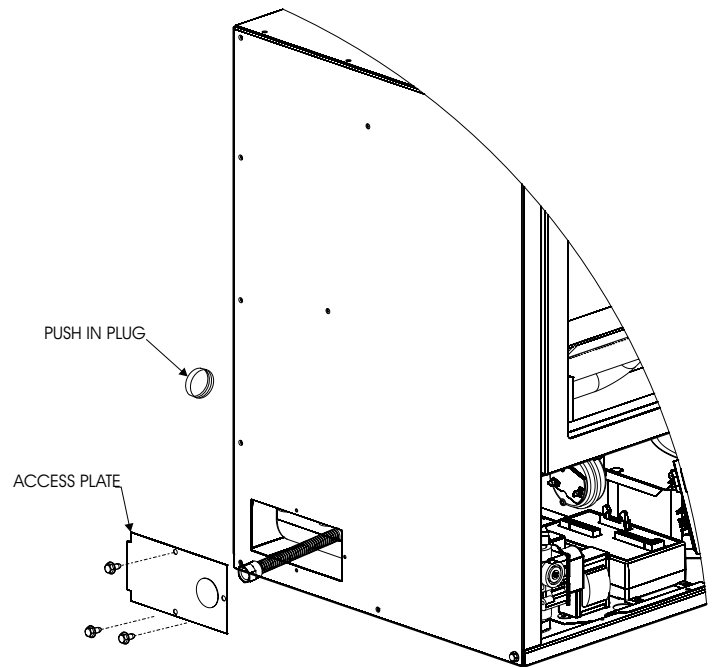

Figure 44
Gas Connection, Fireplace Mantis In-Wall Units

Gas Connection - In-Wall Units

1. Remove the access plate on the left side of the cabinet by removing three screws as shown in Figure 44. Put the screws aside.
2. Push the factory supplied flexible gas line through the access hole on the side.
3. Remove the knockout from the access plate and insert the flexible gas line through the hole.
4. Secure the access plate to the cabinet with three screws removed in Step 1.
5. A plastic push in plug is supplied in the hardware package, insert the plug into the 1-3/8 inch hole in the back of the fireplace.
6. Insert the rubber grommet into the hole in the access plate to protect the flexible gas line.

LIGHTING INSTRUCTIONS

FOR YOUR SAFETY READ BEFORE LIGHTING

WARNING: IF YOU DO NOT FOLLOW THESE INSTRUCTIONS EXACTLY, A FIRE OR EXPLOSION MAY RESULT CAUSING PROPERTY DAMAGE, PERSONAL INJURY, OR LOSS OF LIFE.

- A. BEFORE LIGHTING smell all around the appliance area for gas. Be sure to smell next to the floor because some gas is heavier than air and will settle on the floor.
- WHAT TO DO IF YOU SMELL GAS**
- Do not try to light any appliance
 - Do not touch any electrical switch
 - Do not use any phone in your building.
 - Immediately call your gas supplier from a neighbor's phone.
 - Follow the gas supplier's instructions.
 - If you can not reach your gas supplier, call the fire department.
- B. Use only the wall switch or remote control switch to turn the gas control on/off. Any attempted repairs or adjustments should be performed by a qualified service technician. Applying force or attempted repair may result in a fire or explosion.
- C. Do not use this appliance if any part has been under water. Immediately call a qualified service technician to inspect the appliance and to replace any part of the control system and any gas control which has been under water.

LIGHTING INSTRUCTIONS

1. STOP! Read the safety information above.
2. Turn off the remote thermostat if used.
3. Open bottom louver assembly, or open the service access panel..
4. Turn off all electric power to the appliance.
5. Turn gas line valve to "ON."
6. Wait five minutes to clear out any gas. Then smell for gas, including near the floor. If you smell gas, STOP! Follow "A" in the safety information above. If you do not smell gas, go to the next step.
7. Turn on all electric power to the appliance.
8. Turn on the remote thermostat if used, and set thermostat to desired setting. If remote is not used, activate the appliance using the display panel.

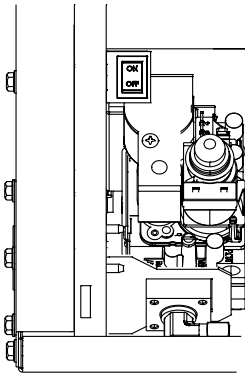

9. This appliance is equipped with an ignition device that automatically lights the burner. Do not try to light the burner by hand.
10. If the appliance will not operate, follow the instructions "TO TURN OFF GAS TO APPLIANCE," and call your service technician or gas supplier.
11. Close bottom louver assembly or close the service access panel.

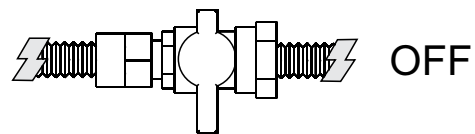

OFF

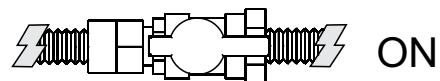

ON

TO TURN OFF GAS TO APPLIANCE

1. STOP! Read the safety information above.
2. Open bottom louver assembly, or open the service access panel.
3. Turn off all electric power to the appliance.
4. Turn gas line valve to "OFF."
5. Close bottom louver assembly, or close service access panel.

WIRING

⚠ WARNING

Potential risk of fire, electric shock, and personal injury. Take precautions to reduce such risks.

⚠ CAUTION

Label all wires prior to disconnection when servicing controls. Wiring errors can cause improper and dangerous operation. Verify proper operation after servicing.

This appliance is equipped with a three-prong [grounding] plug for your protection against shock hazard and should be plugged directly into a properly grounded three-prong receptacle. Do not cut or remove the grounding prong from this plug. For an ungrounded receptacle, an adapter, which has two prongs and a wire for grounding, can be purchased.

Proper line voltage polarity must be maintained in order for the control system to operate correctly. Verify the incoming neutral line is connected to the white wire and the incoming "hot" line is connected to the black wire. The fireplace will not operate properly unless the polarity and ground are correct.

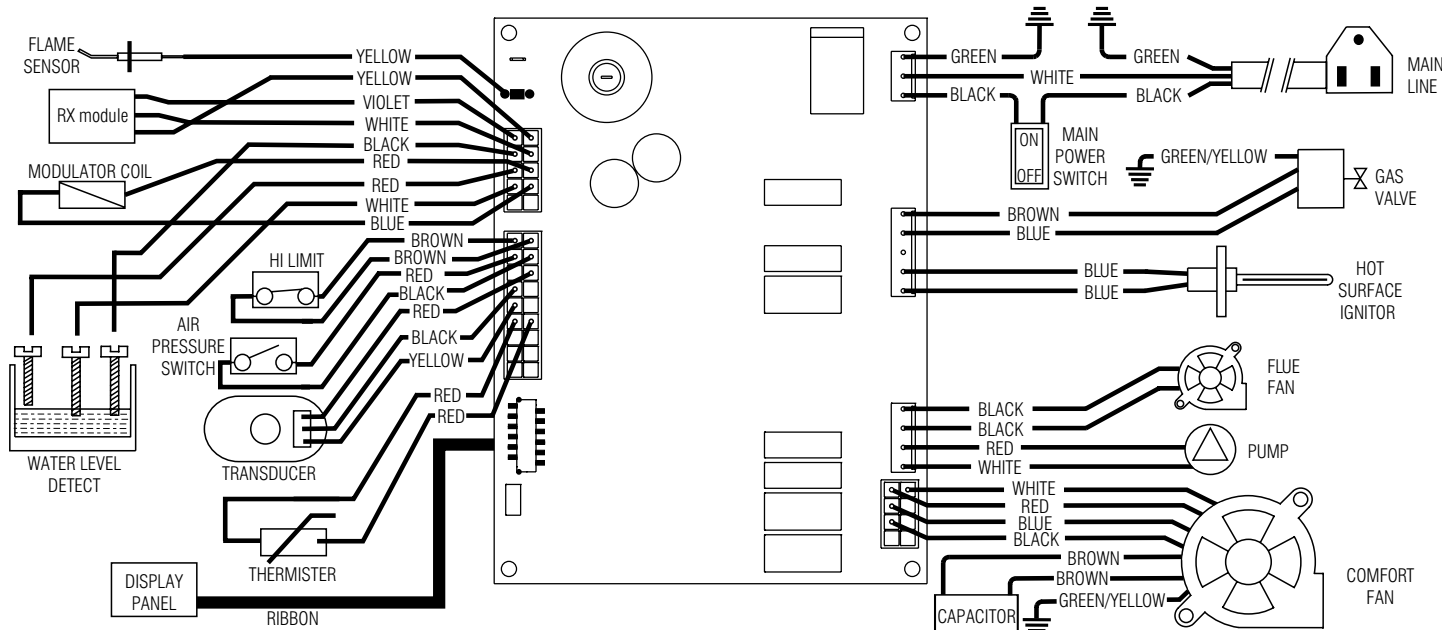

Figure 45

START UP CHECK LIST

⚠ WARNING

BEFORE OPERATING THIS APPLIANCE, CAREFULLY READ THE FOLLOWING.

1. Verify the gas line service does not exceed 10.5 in. w.c. and is not below 5.0 in. w.c. for natural gas, nor exceeds 13.0 in. w.c. or is below 11.0 in. w.c. for LP gas.
2. Check and inspect the appliance for gas leaks. In the event of gas leaks, cut off the gas supply to the fireplace immediately and call your gas supplier. Verify the gas line has been purged.
3. Verify that all exhaust and inlet air pipes are unobstructed and properly joined.
4. Visually verify the burner is free of dust and debris.
5. Verify that all panels are secured in place and that the glass assembly door has been locked in position.
6. Verify that the polarity of the connections are correct and the line voltage power leads are secure.
7. After verifying and checking all the above points, proceed to lighting instructions. Refer to Page 30.

Note: Verify the surround is installed per the instructions included with the kit.

START UP AND ADJUSTMENTS

- A. With main electrical power to the fireplace turned off, install three AAA sized 1.5V batteries into the remote. Set up remote per instructions on pages 34 - 40. After the remote is set up, ensure that the remote is turned on and active. The remote display must show "Auto," "Manual" or "Pilot."

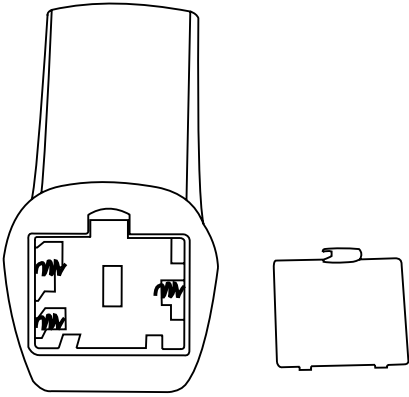

Figure 46

- B. Turn on the main electrical power to the fireplace. See Figure 47. The red and green control board LED lights will begin flashing alternately. Each light will flash four times. Then the fireplace will enter standby and the green LED light will begin to slowly flash. Verify power is on by checking if there is power to the control board. If the fireplace has power, the green LED light on the control board will be flash slowly.

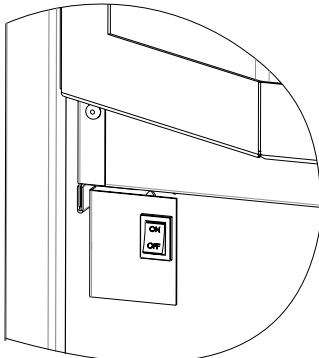

Figure 47

- C. The Display Panel board should be energized, and a "double dash symbol" (- -) the power light will be displayed. See Figure 48. The remote receiver automatically links to the remote transmitter's signal. If the fireplace does not respond to the remote when in remote mode as indicated by the double dash symbol, turn the main power off (Figure 45) and make sure the remote is on and active before turning main power back on.
- D. Turn on the main gas supply.

CAUTION: If the fireplace experiences an unexpected loss of power while the remote is operating in thermostatic mode, the remote's thermostatic function will need to be manually reset after power is restored in order for the fireplace to resume normal operation. Press the remote's power button to turn it off then back on to reset the thermostatic function.

Sequence of Operations

1. Start the fireplace with the remote, or press the display panel's "Mode Select" button (Figure 48) to start the fireplace manually. The Display Panel will energize, and the desired flame level will be displayed.
2. The inducer will activate and perform a safety test lasting 45 seconds. The ignition sequence will initiate after this test.
3. The igniter (HSI) will energize and start to glow red.
4. After 20 seconds, the gas valve will open and ignite the burner on high. The flame sensor will verify the flame is present within six seconds and the green LED light on the control board will illuminate.
5. The gas valve will adjust manifold pressure and inducer speed to match desired flame level.

Note: The fireplace will always ignite on Level 5 (High) prior to adjusting to the flame level on the display panel.

Note: The entire ignition sequence takes approximately one minute, 15 seconds to complete.

6. Use the "Manual Flame Level Adjustment" buttons on the display panel (Figure 48) or the remote control to change the flame level setting.

Note: When changing from a low flame level to a higher flame level, the fireplace will automatically increase to Level 5 (High) prior to proceeding to the desired flame level. This is to ensure consistent operation.

The table below outlines the BTU input rate of the burner for each flame level.

Flame Level	BTU Input
5	20,000
4	17,500
3	15,000
2	12,500
1	10,000

7. As the Mantis warms up, the circulating blower will activate, starting on Low speed (I). The Low Blower speed will display when the blower turns on.
8. As the Mantis continues to operate, the speed of the circulating blower will increase, and the symbols for Medium (2) and High (3) will appear.

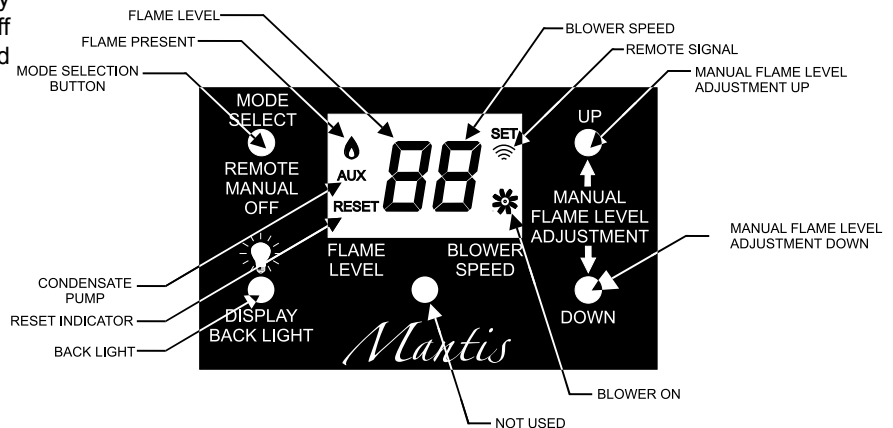

Figure 48

START UP AND ADJUSTMENTS

Display Backlight

The display panel back light will automatically turn off five seconds after an input (either manual or remote) is acknowledged. The back light will automatically turn on when a new input is acknowledged. To turn the back light on manually, press the "Display Backlight" button on the bottom left of the display panel (Figure 48).

Shut Down Instructions

To turn the fireplace off, simply push "OFF" on the remote or push the display panel's mode select button to "OFF". See Figure 49. DO NOT cut the main electrical power to the fireplace.

The circulating blower will continue to operate after the burner is turned off. The blower will stop automatically once the fireplace has cooled down.

Checking Manifold Pressure

Both Propane and Natural gas valves have a built-in pressure regulator in the gas valve. Natural gas models will have a manifold pressure of approximately 3.5 in. w.c. at the valve outlet, with the inlet pressure to the valve at 5.0 in. w.c. to 10.5 in. w.c. Propane gas models will have a manifold pressure approximately 7.0 in. w.c. at the valve outlet, with the inlet pressure to the valve from 11.0 in. w.c. to 13.0 in. w.c.

A pressure tap accessible for test gauge connection, is located on the outlet side of the gas control.

Blower Operation

The circulating air blower will automatically engage and increase in speed depending on the operation of the burner. In most circumstances, the circulating blower will start three to five minutes after ignition of the burner.

Once the fireplace is turned off or the call for heat has been satisfied, the circulating blower will continue to run. The blower will automatically adjust its speed and turn off as the fireplace cools down.

High Altitude

The Mantis can be installed to altitudes up to 10,000 feet in the U.S., and up to 4,500 feet in Canada. The installation must meet the requirements of the National Fuel Gas Code or local jurisdictions.

Humidifier Operation

When the fireplace has been running, the "AUX" symbol on the display panel (Figure 48) will turn on to signal that the pump has been activated. Refer to Page 42 - Automatic Humidifier Operation.

Paint Curing - First Firing

The Mantis Power-Vent High-Efficiency Fireplace has been painted with the high quality heat resistant silicon paint. To ensure that the paint is properly cured, allow the fireplace to operate with both burners on, for approximately one hour. During the initial firing of the appliance, it is common for smoke to appear.

CAUTION

DO NOT touch the surface of the fireplace. The paint will soften during the initial operation, and will harden over time. Once the paint is cured, it will not soften again.

- To prevent triggering of smoke alarms, supply proper ventilation to the room where the unit is installed.
- DO NOT clean the fireplace with any caustic or abrasive cleaning solutions. This will damage the surface.
- Any damage to the painted surfaces should be repaired only with authorized paint available from your Mantis Dealer.

REMOTE INSTRUCTIONS

The remote control and its LCD screen lets you make full use of your fireplace's potential. In particular it enables you to adjust the fireplace's operating parameters, program its timer, and continuously monitor room temperature to control operation.

A room temperature sensor is built into the remote control to ensure accurate measurement of temperature in the room to be heated, at whatever point the user wishes, and without having to install inconvenient thermostat cables.

When the remote is turned on the back-lighting of the remote control screen illuminates as soon as you press any button.

ATTENTION

If the remote control is switched off because there are no batteries in it, it cannot be used to control the fireplace and the fireplace's display panel must be used instead (see page 32). When using the fireplace's display panel for operation only key functions remain enabled: on, off and manual control of the flame levels.

CAUTION

Keep the remote control away from direct heat and water. Keep the remote control away from children. The remote control must always be kept near the fireplace (i.e. within a radius of about 16 feet of it) to ensure correct transmission of measured temperature values.

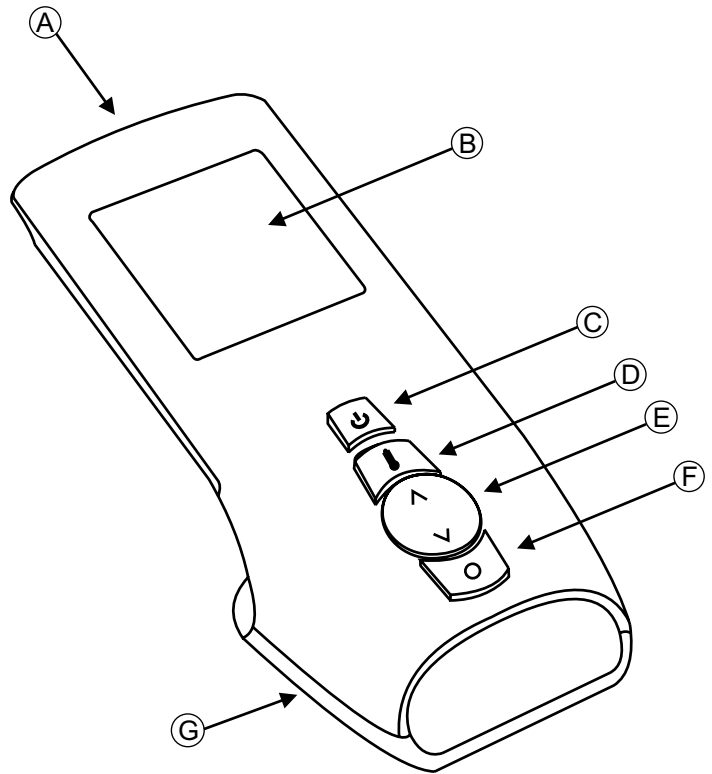

Index No.	Description
A	Temperature sensor location
B	Back-lit LCD display
C	Power button. Use this button to switch the remote On, Off or place the remote in Standby (PILOT) mode.
D	The Mode Select (Manual - Thermostatic) button switches the remote from Manual (MAN) mode to Thermostatic (AUTO) mode. When using this button in conjunction with other buttons you can also access menus like the clock setting menu.
E	Use the up and down button for adjusting the flame level and adjusting the sleep and timer settings.
F	MENU button for accessing sleep and program menus.
G	Base and battery compartment.

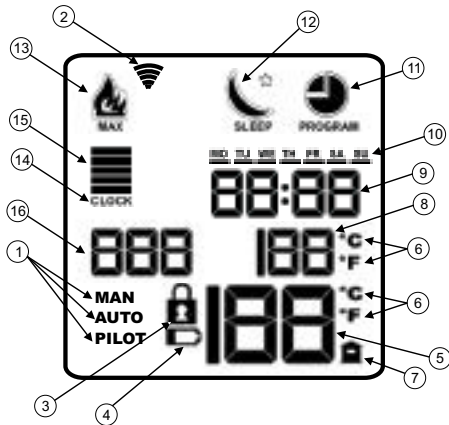

Figure 49 - LCD Remote Control

REMOTE INSTRUCTIONS



Index No.	Description
1	Remote function mode symbols (MANUAL - AUTOMATIC - PILOT)
2	Symbol for remote communication to fireplace
3	Keypad lock symbol. This symbol appears when keypad is locked.
4	Low battery symbol. When this symbol appears without flashing, the batteries must be replaced.
5	The temperature currently measured by the remote control's built-in sensor for the area around the remote control.
6	Temperature units of measurement (Celsius - Fahrenheit).
7	Symbol identifying room temperature measured by the built-in sensor.
8	The thermostatic mode set temperature. This symbol does not appear in MANUAL mode.
9	Clock. The clock functions as a countdown when the SLEEP function is in use.
10	Symbols indicating the current day.
11	TIMER symbol. If this symbol does not appear, the TIMER is not active. If only the outline of the symbol appears, the TIMER is active. A solid black symbol indicates that you are in the TIMER setting menu.
12	SLEEP function symbol. If this symbol does not appear, the SLEEP function is not active. If only the outline of the symbol appears, the SLEEP function is active, meaning that the stove will switch off at the end of the countdown period set by the user and shown by symbol 9. A solid black symbol indicates that you are in the SLEEP setting menu.
13	Flame symbol, indicating the current flame power. If flame power is at level 5, the MAX message also appears.
14	Clock setting symbol. When this symbol appears, you can adjust the clock setting displayed by the digits 9.
15	Flame power bars: one bar = low, five bars = high. These bars only appear when the stove is in MANUAL mode.
16	Digits identifying the weekly TIMER program currently selected.

Figure 50 - The Remote Control Display

NOTE: The program symbol  , sleep symbol  , and flame symbol  can appear in two ways: Solid black or Outline. Solid symbols indicate that you are currently in that function's setting menu.

For example, If the sleep symbol  appears in solid black, you are currently in the sleep timer setting menu and can use the up and down button (E in Figure 51) to change the sleep timer.

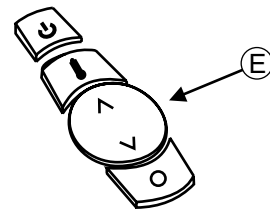



Figure 51

Outline symbols mean that the function is active but that settings cannot be changed unless you first enter the setting menu. When you enter the setting menu, the symbol turns solid black again.

For example, If the sleep symbol appears only in outline, the sleep timer is active and functioning.

Battery Type and Replacement

The batteries are housed in the base of the remote control. The device requires 3 AAA 1.5V batteries. The Low Battery Symbol  on the remote control display tells you when the batteries are running out. If the low batteries symbol  appears, the batteries are nearly discharged and the remote control is about to lose power.

ATTENTION

The batteries may need to be replaced frequently due to the remote control's multiple functions.

CAUTION

When replacing the batteries, take care to respect the polarity symbols inside the remote control's battery compartment.

REMOTE INSTRUCTIONS

SETTINGS REQUIRED PRIOR TO INITIAL START-UP

Setting the Time and Day

When batteries are inserted into the remote control, as during initial setup or when replacing the batteries, the remote will automatically enter the clock setting menu. To reset the clock without removing the batteries, simultaneously press the "O" and Mode buttons on the remote control for five seconds to enter the clock setting menu (Figure 52).

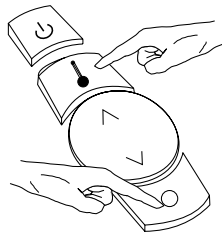

Figure 52

As soon as the first two digits of the clock begin flashing use the up and down button to set the current hour (24 hour clock) then press the "O" button to confirm the new setting (Figure 53). Repeat the procedure to set the minutes and then the day. When you have finished setting the time and the day, press the "O" button again to confirm you settings and exit the menu.

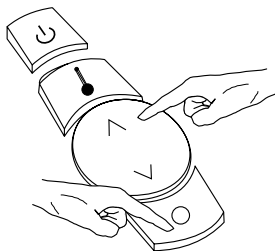
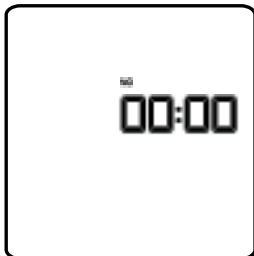

Figure 53

The days of the week are indicated by two-letter codes.

- MO** = Monday
- TU** = Tuesday
- WE** = Wednesday
- TH** = Thursday
- FR** = Friday
- SA** = Saturday
- SU** = Sunday

Note: If the keypad is not used for 7 seconds, the remote control automatically exits the clock setting menu and assumes the last settings entered.

Setting the Units of Temperature Measurement

You can choose to use either degrees Celsius or Fahrenheit as the temperature units of measure.

The remote must be turned off (no backlight) before you can change the temperature units of measure. Press and hold the power button until the screen backlight turns off. Press and hold the Mode button (Figure 54) for at least five seconds to switch fireplace measure between degrees Celsius (°C) and degrees Fahrenheit (°F).

The remote control's default setting is degrees Celsius (°C). Press and hold the power button until the screen lights to turn remote on.

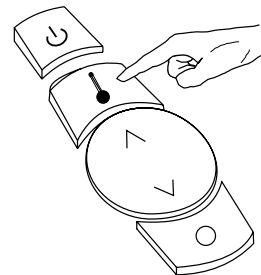
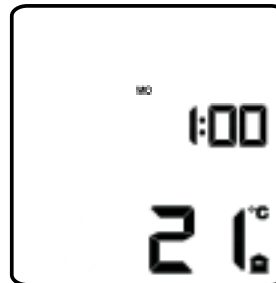



Figure 54

REMOTE INSTRUCTIONS

ACTIVATING THE KEYPAD LOCK

The remote control has a function for locking the keypad to prevent accidental modifications to fireplace settings as the result of buttons being pressed inadvertently or children playing with the remote control.

To activate the keypad lock, press and hold the “O” button, the

lock symbol  will appear on the screen to confirm that the keypad is locked (Figure 55). Repeat the procedure to deactivate the keypad lock.

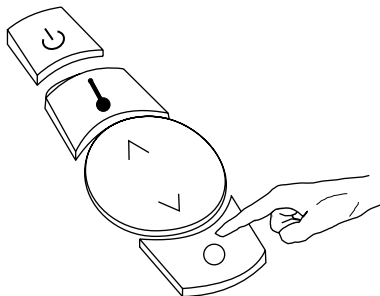
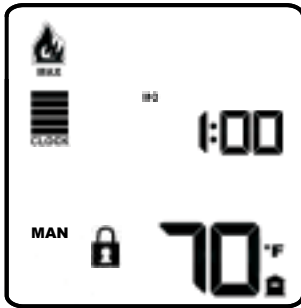

Figure 55

INITIAL START-UP

Starting Up / Shutting Down the Fireplace from the Remote Control

ATTENTION

BEFORE YOU CAN USE THE REMOTE CONTROL TO OPERATE THE FIREPLACE, THE FIREPLACE MODE MUST BE SET TO "REMOTE". THE FIREPLACE DISPLAY PANEL WILL SHOW A DOUBLE DASH "--" WHEN IN REMOTE MODE.

Use the remote control power button to start up the fireplace. If the remote is in standby (PILOT) mode, press and release the power button. If the remote is off, press and hold the power button for two seconds. See Figure 56.

After a start-up phase lasting about one minute, 15 seconds the fireplace enters normal functioning mode.

To shut down the fireplace, press and release the power button on the remote to place it in standby (PILOT) mode or hold the power button for two seconds to turn the remote off. When the fireplace is shut down, a post-purge procedure starts. This shuts down the gas valve, runs exhaust for ten seconds and keeps the fan running until the fireplace has cooled to a safe temperature. The post-purge phase lasts for several minutes depending on how long the fireplace has been running and the flame level setting in use.

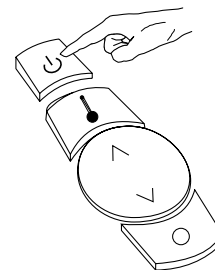
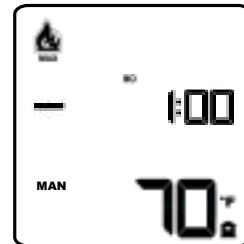

Figure 56

Starting Up / Shutting Down the Fireplace from the Display Panel

If the remote control develops a fault or its batteries run out, you can operate the fireplace from its display panel. See page 32 for further information.

REMOTE INSTRUCTIONS

REMOTE FUNCTIONING MODES

Manual Mode

In manual mode you can adjust the fireplace's heat output up or down by changing the flame level. See Figure 57. Press the mode button on the remote control to select MANUAL mode. The mes-

sage MAN and the flame symbol  appear on the display. Once in manual mode, use the up and down button to move through the five flame levels.

Press arrow up to increase flame level or press arrow down to decrease flame level. The current setting is shown by the number

of bars  appearing under the flame symbol. When all five bars are shown, the message MAX also appears under the flame symbol to show that the fireplace is set to maximum flame level. When you are in manual mode, the flame symbol appears in solid black.

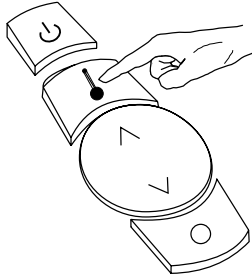
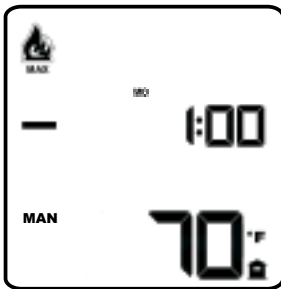

Figure 57

Switching from Manual to Thermostatic Mode

To switch from MANUAL to THERMOSTATIC mode, press the mode button. The message MAN disappears and the message AUTO appears instead. The flame level bars also disappear along with the flame symbol. In their place the digits for setting room temperature appear. See Figure 58.

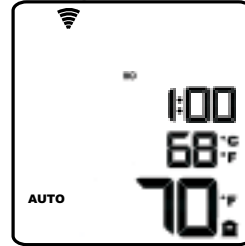

Figure 58

THERMOSTATIC Mode

Whereas MANUAL mode only lets you adjust the flame level and maintain that setting until you change it again, THERMOSTATIC (AUTO) mode lets you set the temperature you want to maintain in the room. **In thermostatic mode the fireplace automatically adjusts flame power level to reach the set room temperature.**

After you switch to THERMOSTATIC mode, use the up and down button to change the room temperature setting.

Press arrow up to increase the temperature setting or arrow down to decrease it. The current setting is shown below the clock (Figure 59).

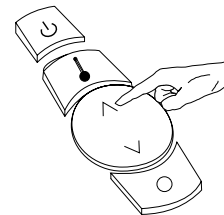
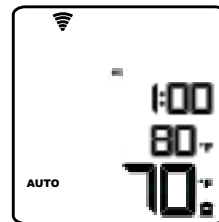



Figure 59

REMOTE INSTRUCTIONS

The remote control adjusts the functioning of the fireplace by continuously comparing measured room temperature (shown at the bottom right of the display by the large numbers just to the left of

the “home” symbol ) with the desired temperature set by the user.

When the required temperature is reached in the room, the fireplace gradually reduces its power until it shuts off. If room temperature then drops below a certain temperature, the fireplace will relight gradually increase flame level up to the maximum again.

Room temperature is measured by the remote control’s own built-in sensor. The fireplace will therefore attempt to achieve a temperature based on the measurements of the remote control. This means that the remote control acts as a genuine MOBILE THERMOSTAT, within a range of about 16 feet of the fireplace (with fully charged batteries).

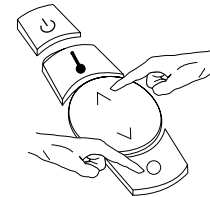
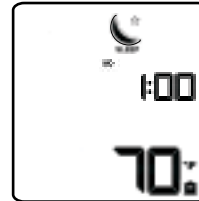

Figure 60

When you exit the SLEEP setting menu, the display shows the sleep symbol as an outline and the countdown time to fireplace shut-down instead of current time.

Note: If the keypad is not used for 7 seconds, the remote control automatically exits the sleep setting menu and assumes the last settings entered.

CAUTION: If the fireplace experiences an unexpected loss of power while the remote is operating thermostatic mode, the remote’s thermostatic function will need to be manually reset after power is restored in order for the fireplace to resume normal operation. Press the remote’s power button to turn it off then back on to reset the thermostatic function.

Note: Since the remote control acts as a room thermostat, the right conditions must be maintained for proper communications between the remote control and the stove. You should always keep the remote control in the area heated by the fireplace and always within a range of 16 feet from it. Avoid keeping the remote control too near the fireplace however, since the hot air in the immediate vicinity of the fireplace could affect the remote control’s room temperature.

Note: Keep the remote control in the room where the fireplace is installed, so that the fireplace and remote control can communicate with each other. If you take the remote control outside the range of communications with the fireplace, the fireplace will no longer receive any room temperature measurements and will therefore continue to function at the same power setting that was established before communications failed.

Deactivating SLEEP Mode

To deactivate sleep mode, enter the sleep setting menu. The sleep



symbol  will appear. Use the up and down button to set the countdown setting to 0. Wait seven seconds or press the “O” button twice to confirm the setting. Sleep mode is now deactivated, and the sleep symbol will be gone.

Selecting a program

SETTING A WEEKLY PROGRAM

To select a weekly program press the “O” button twice to enter



the program menu until the timer symbol  appears on the display (Figure 60).

You can now use the up and down button to select one of ten pre-set weekly programs in the remote control.

Refer to the Table (Figure 62) to choose the program that best suits your home’s heating requirements and select its number on the remote control.

Switching from Thermostatic to Manual Mode

To return to MANUAL mode from THERMOSTATIC mode, repeat the steps used to switch from Manual to Thermostatic Mode.

Sleep Function

This function is designed to shut down the fireplace after a certain time.

The SLEEP function allows you to set a countdown period of eight hours in 15 minute increments, at the end of which the fireplace will shut down.

To activate the SLEEP function, press the “O” button twice. The



sleep symbol  will appear on the screen indicating that you are in the sleep timer setting menu.

The figures 00:00 appear in place of the current time. Use the up and down button to set the countdown time. Press arrow up to increase the countdown setting, or press arrow down to decrease the countdown setting. To confirm the setting and exit the sleep setting menu, press the “O” button twice more (see Figure 60).

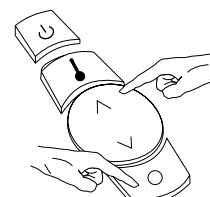
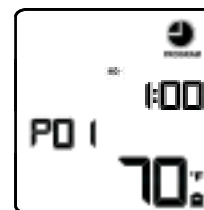



Figure 61

REMOTE INSTRUCTIONS

Note: If the keypad is not used for seven seconds, the remote control automatically exits the program menu and assumes the last settings entered in the program menu..

Press the “O” button again to confirm your choice and exit the program menu. The CLOCK symbol  remains displayed in outline on the remote control screen.

When the outlined clock symbol is displayed, a program is active and the fireplace will be started up and shut down at set times every day of the week.

IMPORTANT! When program mode is active, the clock symbol  is displayed on all screens of the remote control. PROGRAM mode can be activated/deactivated with the fireplace functioning or shut down.

You can start up or shut down the fireplace manually even if a program is active. Manual commands take precedence over program commands. The next program command will be ignored.

Example: if the timer is due to start the fireplace at 10:00, but you already feel cold at 9:00 and want to start the fireplace up early, press the up and down button. The command to start the fireplace at 10:00 will then be ignored because the fireplace will already be functioning.

Deactivating PROGRAM mode

To deactivate PROGRAM mode, enter the program setting menu.



The clock symbol **PROGRAM** will appear. Use the up and down button to select “OFF.”

Wait seven seconds or press the “O” button again to confirm the setting. Program mode is now deactivated, and the clock symbol will be gone.

The chart below outlines the timing of the 10 pre-set programs. The shaded areas show the time when the appliance would be ON.

Weekly Program		Timetable																										
No.	Days	12:00 AM	1:00 AM	2:00 AM	3:00 AM	4:00 AM	5:00 AM	6:00 AM	7:00 AM	8:00 AM	9:00 AM	10:00 AM	11:00 AM	12:00 PM	1:00 PM	2:00 PM	3:00 PM	4:00 PM	5:00 PM	6:00 PM	7:00 PM	8:00 PM	9:00 PM	10:00 PM	11:00 PM	12:00 AM		
P01	Mon - Fri																											
	Sat - Sun																											
P02	Mon - Fri																											
	Sat - Sun																											
P03	Mon - Fri																											
	Sat - Sun																											
P04	Mon - Sat																											
	Sun																											
P05	Mon - Sat																											
	Sun																											
P06	Mon - Fri																											
	Sat - Sun																											
P07	Mon - Fri																											
	Sat - Sun																											
P08	Mon - Fri																											
	Sat - Sun																											
P09	Mon - Fri																											
	Sat - Sun																											
P10	Fri																											
	Sat - Sun																											

Table, Figure 62

TROUBLESHOOTING

TROUBLESHOOTING LCD CODES - NORMAL OPERATION		
OPERATION	LCD DIGITS	CONTROL BOARD LED SEQUENCE
Power on sequence	Blank	Yellow LED permanently OFF
		Green and red LED blink four times alternately
Standby	" - "	Yellow LED permanently OFF
		Red LED permanently OFF
		Green LED blinking slowly and continuously
Operation Safety Check	Desired flame level is shown	Yellow LED on at pressure threshold check
		Green and red LED's blink rapidly and alternately
Heat Request	Desired flame level is shown	Yellow LED permanently OFF
		Red LED permanently OFF
		Green LED blinking fast and continuously
Run	Desired flame level is shown	Red LED permanently OFF
		Green LED permanently ON

TROUBLESHOOTING LCD FAULT CODES ON THE DISPLAY PANEL			
FAULT DESCRIPTION	LCD Digits	Description	ACTION
Anomaly as parasitic flame, APT failure or APS failure	Desired flame level is shown	Yellow LED permanently OFF	Turn off main electrical power to the fireplace for 30 minutes then retry ignition.
		Green and red LED blink slowly and simultaneously	
Ignition lock-out	"A1"	Yellow LED permanently OFF	Check gas presence Check flame detection probe Check ignition probe
		Red LED permanently ON	
		Green LED performs one blink followed by a one second pause	
High water level fault	"A2"	Yellow LED permanently OFF	Check pump functionality
		Red LED permanently ON	
		Green LED performs two blinks followed by a one second pause	
Transducer fault	"A3"	Yellow LED permanently OFF	Check Air pressure sensor connection. Check fan functionality. Check for flue blockage
		Red LED permanently ON	
		Green LED performs two blinks followed by a one second pause	
Pressure switch fault	"A4"	Yellow LED permanently OFF	Check APS device. Check fan functionality. Check for flue blockage
		Red LED permanently ON	
		Green LED performs 4 blinks followed by a one second pause	
Overheat lock-out	"A5"	Yellow LED permanently OFF	Check room fan functionality
		Red LED permanently ON	
		Green LED performs 5 blinks followed by a one second pause	
Thermister failure	"A6"	Yellow LED permanently OFF	Check firebox probe connection
		Red LED permanently ON	
		Green LED performs 6 blinks followed by a one second pause	
Inadequate Combustion Airflow	"A7"	Yellow LED permanently OFF	Check for flue restriction
		Red LED permanently ON	
		Green LED performs 7 blinks followed by a three second pause	
Thermister temp too high	"A0"	Yellow LED permanently OFF	Check room fan functionality
		Red LED permanently ON	
		Green LED performs one blink followed by a three second pause	

AUTOMATIC HUMIDIFIER OPERATION

The Mantis Power-Vent High-Efficiency Fireplace has an automatic humidifier designed into the fireplace. As the fireplace operates, condensate is created and is collected in a tank inside the fireplace. The condensate pump will take the collected condensate and pump it to a stainless steel tray where it evaporates into the airstream, adding humidity to the heated space.

Note: When the automatic humidifier is engaged and is transferring the condensate, there may be a noticeable hissing sound. This is normal, and the sound should persist for less than 30 seconds.

The amount of condensate created will vary based on several factors including but not limited to location of fireplace, air temperature, length of venting, and whether the vent pipe is horizontal or vertical. The humidifier will operate intermittently while the fireplace is operating.

While the condensate pump is transferring the condensate from the tank to the tray, the "AUX" symbol will display during pump operation. See Page 32, Figure 48. Once the condensate is transferred, the symbol will turn off.

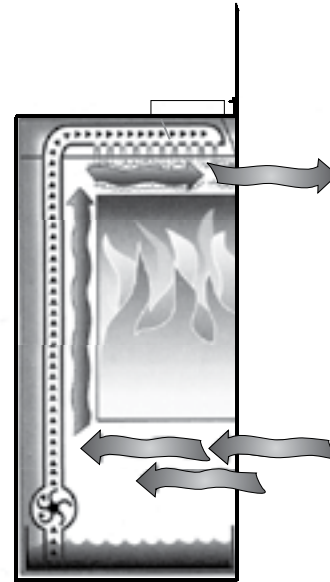

Figure 63

MAINTENANCE & SERVICE

The Mantis should be inspected and serviced annually by a qualified service person. This will ensure that the appliance is operating safely and efficiently. Should you suspect any abnormal operation, contact a service person that has been trained to service this product.

Cleaning the Glass Door

After the initial paint curing, a slight film may form on the glass. It is recommended to clean the glass with gas fireplace glass cleaner.

The glass will need to be cleaned periodically during the year. Use care when removing and cleaning the glass. In the event the glass needs replaced, contact a qualified service person. Only glass approved by Empire Comfort Systems Inc. may be used, any substitute glasses will void the warranty.

CAUTION

Do not attempt to clean the glass when it is hot. Do not strike or hit the glass.

WARNING

Do not operate this appliance without the glass door in place. Do not operate if the glass front is broken or damaged. Do not use the glass door if the gasket is missing or is damaged.

CAUTION

Be certain the glass is cool before handling.

Removing the Glass Door

1. Remove the lower louvered panel by lifting up then pulling out.
2. Release the two hinge clips on underside of firebox.
3. Angle the bottom of glass assembly approximately 60 degrees out from firebox. Gently pull glass assembly away from firebox. Do not damage or remove the gasket from the door.

Resetting the Fireplace

WARNING

Potential risk of fire, electric shock, and personal injury. Take precautions to reduce such risks

CAUTION

Label all wires prior to disconnection when servicing controls. Wiring errors can cause improper and dangerous operation. Verify proper operation after servicing.

To reset the fireplace, press the mode selection button on the display panel repeatedly until the fireplace cycles through the "OFF" setting once. If the error has been cleared, the fireplace will operate normally. If the error is still present, consult a qualified service technician.

Cleaning the Porcelain Liners

Over time a film may form on the porcelain liners. It is recommended to clean the liners with gas fireplace glass cleaner. The liners will need to be cleaned periodically during the year. The glass door will need to be removed to clean the liners. Use care when removing the glass. In the event the liners need to be replaced, contact a qualified service person. Only liners supplied by Empire Comfort Systems may be used. Any substitute will void the warranty.

MAINTENANCE & SERVICE

Circulating Air Blower

The circulating air blower should be checked and cleaned annually by a qualified service person to ensure that your appliance is operating efficiently. Any dirt or lint can affect the operation of the blower.

Heat Exchanger

The heat exchanger is located on the backside of the fireplace. The heat exchanger should be inspected and cleaned annually by a qualified service person.

Filter

The filter is located on the inside of the lower louver panel (on fireplaces equipped with FIKQ, FFKQ or FWKQ Surrounds) or on the inside bottom flange of the surround (FHKQ Surrounds).

To clean the filter on fireplaces equipped with the lower louver panel, remove the louvered panel and disengage the filter rod from its retaining holes (Figure 64).

For fireplaces equipped with louverless FHKQ surrounds, the entire surround must be removed from the fireplace. To remove the surround, lift and remove from the support bracket hooks. Remove the filter retainers and filters from the inside bottom flange by removing the screw holding the filter retainer in place (Figure 65).

The filters may be rinsed with water or blown clean with compressed air. Allow the filters to dry completely before reinstalling them.

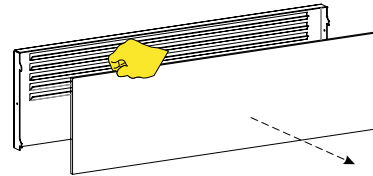
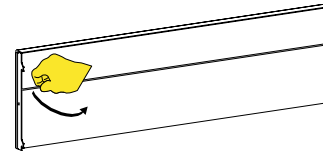

Figure 64

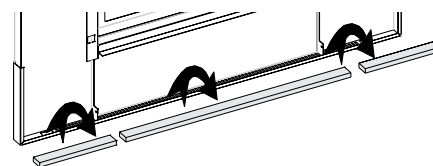
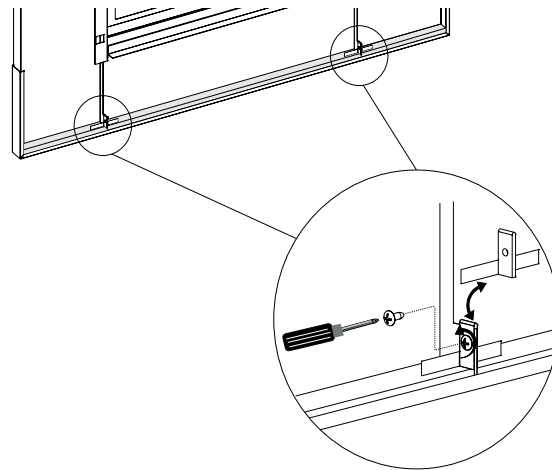

Figure 65

RECOMMENDED MAINTENANCE		
MAINTENANCE ITEM	FREQUENCY OF MAINTENANCE	
	MONTHLY BY HOMEOWNER	ANNUALLY BY SERVICE PERSON
Verify the area is free from combustible materials.	X	X
Verify the combustion and ventilation air is not restricted.		X
Verify the flue and inlet pipes do not have any cracks or holes.		X
Verify burner flame.		X
Clean the blower compartment		X
Clean the burner.		X
Verify the condensate system is clean and leak free.		X
Clean the Filter	X	X
Clean the Liners	X	X
Clean the Glass	X	X

If service is needed to the condensate pump, the wires must be attached in the same order they were removed (Figure 66). If the pump is replaced, follow the wire connection instruction label on the pump cover.

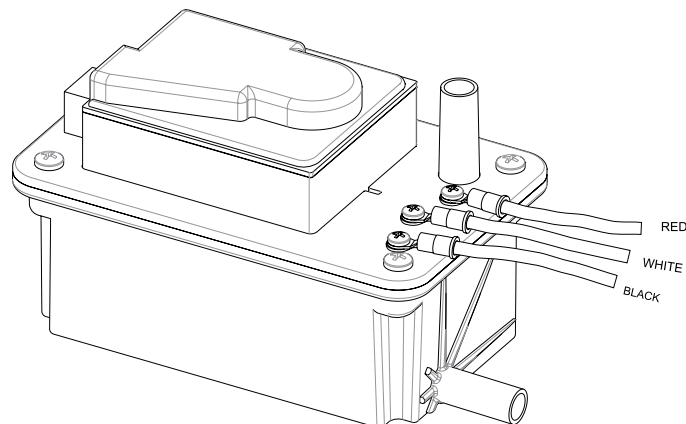

Figure 66

DECORATIVE GLASS ACCESSORY INSTALLATION

WARNING

Failure to position the parts in accordance with the diagrams and instructions below or failure to use only parts specifically approved for use with this heater may result in property damage or personal injury.

Notice: The G-Class series Mantis may be operated with or without the Decorative accessory options. Follow the directions below should you choose to enhance your fireplace with any one of the available decorative options.

DECORATIVE GLASS OR ROCK MEDIA ACCESSORY PLACEMENT

Note: The G-Class Series Mantis fireplace will accept two square feet of decorative media.

Empire Comfort Systems offers a selection of decorative media for the G-Class series Mantis fireplace. It is approved for use with glass media measuring as small as 1/4 inch and up to 1-1/4 inch in diameter. See page 7. Additional colors may be available from your Empire dealer. Empire Comfort Systems approved rock media may also be used. See page 7.

Use properly sized media - crushed, smooth, small, large, or a combination - to create the desired look. Follow the diagrams in this manual for placement of media and clearance to burner openings.

CAUTION

Use of gloves and eye protection is required while applying the decorative glass.

CAUTION

Use only decorative glass media approved for use in gas fireplaces.

CAUTION

Use only Empire Comfort Systems approved decorative rock media.

INSTALLATION

1. Application of the Decorative Media should only be performed after the fireplace has been fully installed, secured and tested for leaks.
2. To install the Decorative Media, cut off a corner of the plastic bag and proceed to apply the media to the rear of the porcelain liner bottom (area behind the burner). Apply only enough media to the porcelain liner bottom to cover the black metal surface. Do not allow the media to fall around the burner tube. See Figures 67 to 69. Apply the remaining decorative media to the front area of the porcelain liner bottom. Start by placing the media along the front of the porcelain liner bottom, then gradually place the media up the porcelain liner bottom until completely covered. Do not allow the media to fall around the burner tube. See Figures 61 to 69.

CAUTION

Never stack decorative media higher than the burner opening flanges when within two inches of the burner opening. See Figure 70

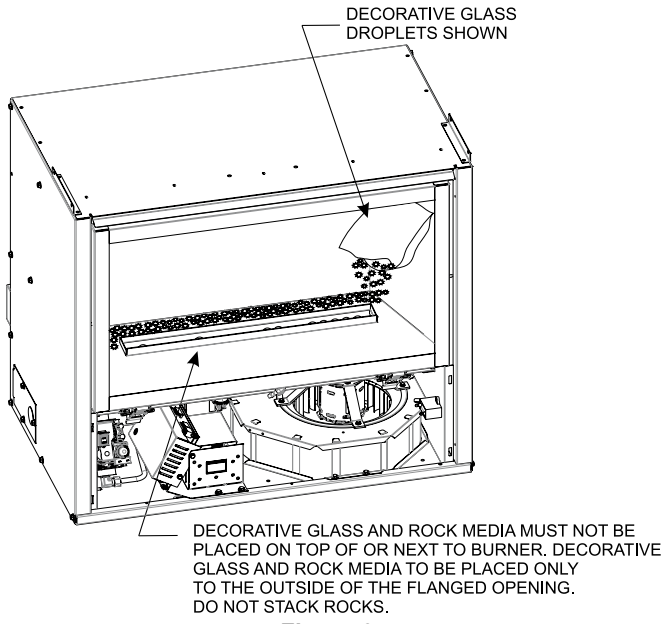

Figure 67

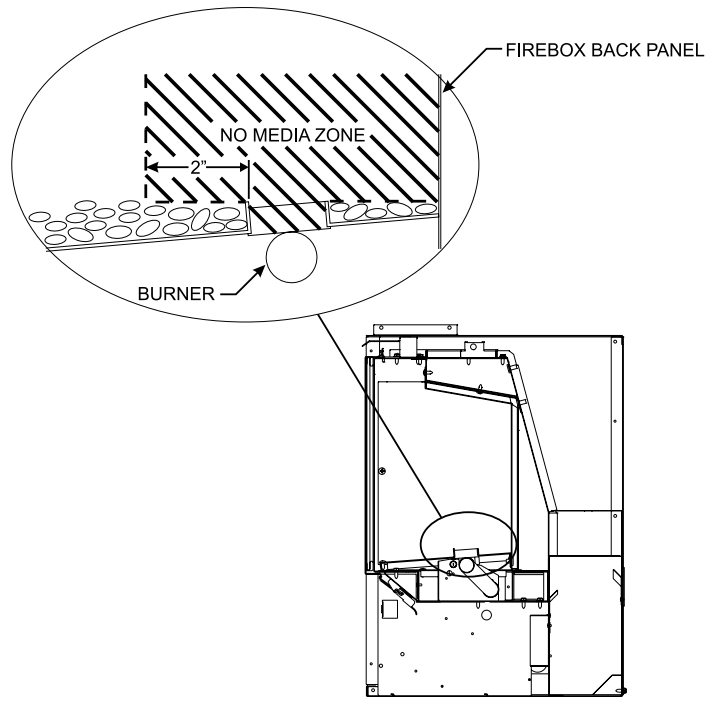

Figure 70

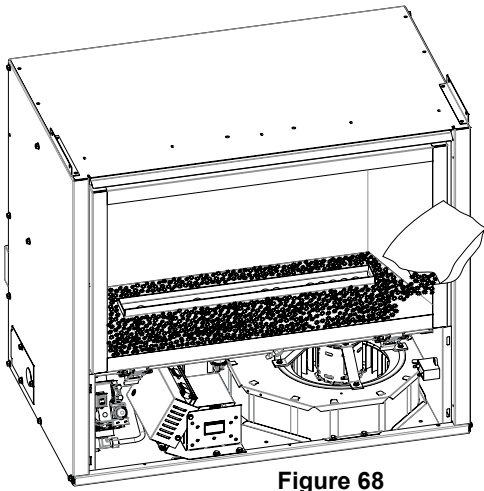

Figure 68

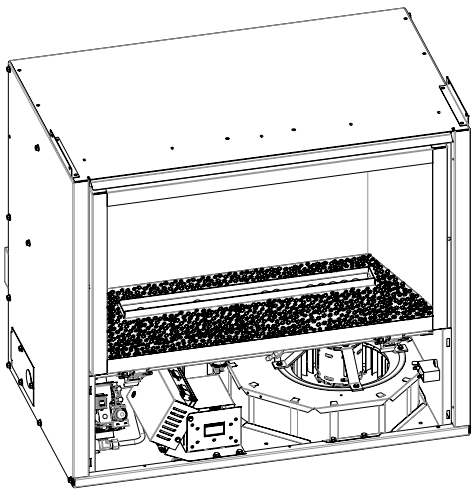

Figure 69

PARTS LIST

⚠ WARNING

Use only manufacturer's replacement parts. Use of any other parts could cause injury or death.

INDEX NO.	PART NO.	DESCRIPTION
1	25216	BRACKET, STANDOFF (TWO REQUIRED)
2	25207	PANEL - TOP
3	25223	LOUVER - TOP
4	21595	CONDENSATE TRAY
5	25222	DOOR BRACKET (TWO REQUIRED)
6	26121	BRACKET, INLET HEADER
7	25204	PANEL - BACK
8	24831	REAR HEAT SHIELD ASSEMBLY
9	26089	FLEX PIPE ASSEMBLY (REQUIRES TWO #10)
10	R10337	GASKET, CONNECTOR PLATE (TWO REQUIRED)
11	21654	BRACKET, PIPE ASSEMBLY
12	R10299	SWITCH, BIMETALIC
13	26119	HEADER COVER - OUTLET
14	29424	INDUCER ASSEMBLY (REQUIRES #16)
15	21627	SHIELD, REAR INNER
16	R8795	GASKET - SUMP
17	29721	HEAT EXCHANGER ASSEMBLY (INCLUDES # 6, 9, 10 & 16)
18	25205	PANEL - LEFT SIDE
19	25695	BRACKET, SHIELD (TWO REQUIRED)
20	26706	ACCESS PLATE
21	25214	PANEL - RIGHT SIDE
22	21605	INLET AIR DUCT COVER
23	22780	INLET AIR DUCT ASSEMBLY
24	R10491	INLET AIR DUCT GASKET
25	R9987	FLEX LINE
26	R10822	ELBOW, 90 DEGREE 3/8 NPT X 3/8 FLARE
27	29447	VALVE BRACKET (TWO REQUIRED)
28	29722	VALVE ASSEMBLY - NAT
28	29723	VALVE ASSEMBLY - LPG
29	R6207	ELBOW, 90 DEGREE 5/16 X 3/8 NPT
30	29425	SUPPLY TUBING
31	R11391	PRESSURE SWITCH
32	29450	CONTROL BOARD COVER
33	R11726-00	CONTROL BOARD

INDEX NO.	PART NO.	DESCRIPTION
34	29419	ELECTRICAL PARTS PLATE
35	R11189	DISPLAY BOARD
36	25325	CONDENSATE PUMP COVER
37	29752	PUMP ASSEMBLY
38	29448	TRANSDUCER BRACKET, UPPER
39	R12064	AIR PRESSURE TRANSDUCER
40	29449	TRANSDUCER BRACKET, LOWER
41	29421	CIRCULATING BLOWER ASSEMBLY
42	R8880	CAPACITOR 4uF
43	22773	THERMISTER
44	R11199	WIRE HARNESS, MAIN POWER
45	R11197	WIRE HARNESS, MAIN
46	29436BL	PORCELAIN LINER SIDE PANEL - LEFT
47	29438BL	PORCELAIN LINER SIDE PANEL - RIGHT
48	29434BL	PORCELAIN LINER BACK PANEL ASSEMBLY
49	29441BL	PORCELAIN LINER BOTTOM ASSEMBLY
50	29446	LINER SUPPORT PLATE
51	29445	AIR DUCT CHANNEL
52	R11196	BURNER
53	P200	ORIFICE HOLDER
54	22865	HOT SURFACE IGNITOR
55	29444	BURNER MOUNTING BRACKET
56	R8807	FLAME SENSOR
57	26071	GLASS ASSEMBLY
N/S	25225	LATCH BRACKET (TWO REQUIRED)
N/S	R10072	GAS SHUT OFF VALVE
N/S	R11190	REMOTE TRANSMITTER
N/S	R11191	REMOTE RECEIVER
N/S	R2522	MAIN POWER SWITCH
N/S	R4053	DOOR LATCH (TWO REQUIRED)
N/S	R7572	JAMB NUT
N/S	P314	ORIFICE 2.25mm - NAT
N/S	P214	ORIFICE #53 - LP
N/S	R11192	TUBING (SUMP TO PUMP)
N/S	R7624	AIR SHUTTER

N/S - NOT SHOWN

PARTS VIEW

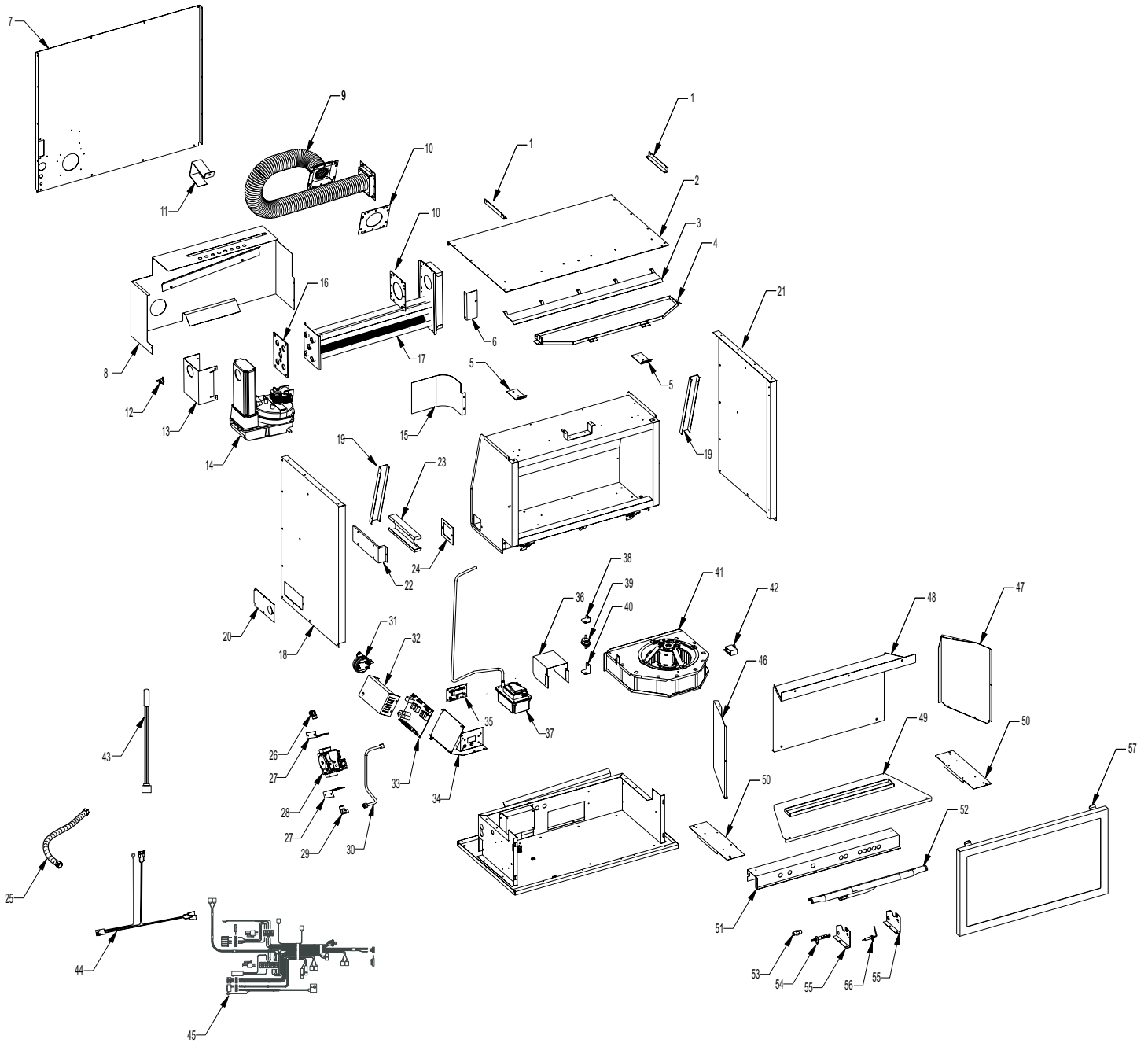

MASTER PARTS DISTRIBUTOR LIST

To Order Parts Under Warranty, please contact your local Empire dealer. See the dealer locator at www.empirecomfort.com. To provide warranty service, your dealer will need your name and address, purchase date and serial number, and the nature of the problem with the unit.

To Order Parts After the Warranty Period, please contact your dealer or one of the Master Parts Distributors listed below. This list changes from time to time. For the current list, please click on the Master Parts button at www.empirecomfort.com. Please note: Master Parts Distributors are independent businesses that stock the most commonly ordered Original Equipment repair parts for Heaters, Grills, and Fireplaces manufactured by Empire Comfort Systems Inc.

Dey Distributing

1401 Willow Lake Boulevard
Vadnais Heights, MN 55101

Phone: 651-490-9191

Toll Free: 800-397-1339

Website: www.deydistributing.com

Parts: Heater, Hearth and Grills

Victor Division of F. W. Webb Company

200 Locust Street
Hartford, CT 06114

Phone: 860-722-2433

Toll Free: 800-243-9360

Fax: 860-293-0479

Toll Free Fax: 800-274-2004

Websites: www.fwwebb.com & www.victormfg.com

Parts: Heater, Hearth and Grills

East Coast Energy Products

10 East Route 36
West Long Branch, NJ 07764

Phone: 732-870-8809

Toll Free: 800-755-8809

Fax: 732-870-8811

Website: www.eastcoastenergy.com

Parts: Heater, Hearth and Grills

HOW TO ORDER REPAIR PARTS

Parts Not Under Warranty

Parts can be ordered through your Service Person, Dealer, or a Master Parts Distributor. See this page for the Master Parts Distributors list. For best results, the **service person or dealer** should order parts through the distributor. Parts can be shipped directly to the **service person/dealer**.

Warranty Parts

Warranty parts will need a proof of purchase and can be ordered by your Service Person or Dealer. Proof of purchase is **required** for warranty parts.

All parts listed in the Parts List have a Part Number. When ordering parts, first obtain the Model Number and Serial Number from the name plate on your equipment. Then determine the Part Number (**not** the Index Number) and the Description of each part from the following illustration and part list. Be sure to give all this information . . .

Appliance Model Number _____ Part Description _____

Appliance Serial Number _____ Part Number _____

Type of Gas (Propane or Natural) _____

Do not order bolts, screws, washers or nuts. They are standard hardware items and can be purchased at any local hardware store.

Shipments contingent upon strikes, fires and all causes beyond our control.

WARRANTY

Empire Comfort Systems Inc. warrants this Mantis fireplace to be free from defects at the time of purchase and for the periods specified below. Mantis fireplaces must be installed by a qualified technician and must be maintained and operated safely, in accordance with the instructions in the owner's manual. This warranty applies to the original purchaser only and is not transferable. All warranty repairs must be accomplished by a qualified gas appliance technician.

Limited Lifetime Parts Warranty – Factory-Installed Glass

If the factory-installed glass fails because of defective workmanship or material, Empire will repair or replace at Empire's option.

Limited Ten-Year Parts Warranty – Combustion Chamber

Empire promises to the owner that if the combustion chamber (see parts list) fails because of defective workmanship or material within ten years from the date of purchase, Empire will repair or replace at Empire's option.

Limited Five-Year Parts Warranty – All Other Components (Except Thermostats)

Should any part fail because of defective workmanship or material within five years from the date of purchase, Empire will repair or replace at Empire's option.

Limited Two-Year Labor Warranty – All Components (Except Remote Controls, Thermostats)

Within two years from the date of purchase, Empire will pay reasonable labor to have defects repaired at Empire's option.

Limited One-Year Parts Warranty – Remote Controls, Thermostats

Should any remote control or thermostat fail because of defective workmanship within one year from the date of purchase, Empire will repair or replace at Empire's option.

Duties of the Owner

The appliance must be installed by the selling dealer or his designated installer and operated in accordance with the instructions furnished with the appliance.

A bill of sale, cancelled check, or payment record should be kept to verify purchase date and establish warranty period.

Ready access to the appliance for service.

What Is Not Covered

Damages that might result from the use, misuse, or improper installation of this appliance.

Travel, diagnostic costs and freight charges on warranted parts to and from the factory.

Claims that do not involve defective workmanship or materials.

Unauthorized service or parts replacements.

Removal and reinstallation cost.

Inoperable due to improper or lack of maintenance.

How To Get Service

To make a claim under this warranty, please have your receipt available and contact your installing dealer. Provide the dealer with the model number, serial number, type of gas, and purchase verification. The installing dealer is responsible for providing service and will contact the factory to initiate any warranted parts replacements. Empire will make replacement parts available at the factory. Shipping expenses are not covered.

If, after contacting your Empire dealer, service received has not been satisfactory, contact: Consumer Relations Department, Empire Comfort Systems Inc., PO Box 529, Belleville, Illinois 62222, or send an e-mail to info@empirecomfort.com with "Consumer Relations" in the subject line.

Your Rights Under State Law

This warranty gives your specific legal rights, and you may also have other rights, which vary from state to state.



Empire Comfort Systems Inc.
918 Freeburg Ave. Belleville, IL 62220

If you have a general question about our products, please e-mail us
at info@empirecomfort.com.

If you have a service or repair question, please contact your dealer.

www.empirecomfort.com