

This Owner's Manual is provided and hosted by Appliance Factory Parts.



Monessen Hearth GDVT36NV Owner's Manual

[Shop genuine replacement parts for Monessen Hearth
GDVT36NV](#)

PARTS LIST / ILLUSTRATION - Firebox

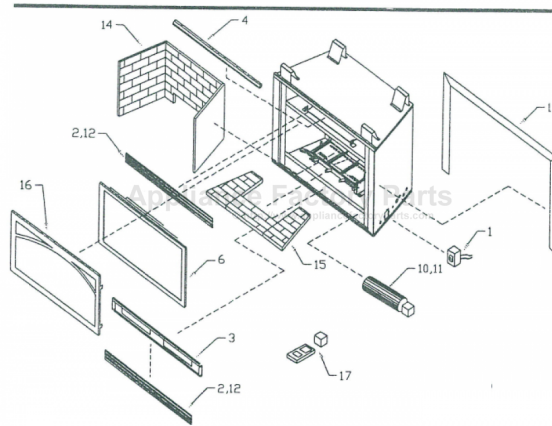

[Find Your Monessen Hearth Fireplace Parts - Select From 701 Models](#)

----- Manual continues below -----

DIRECT VENT GAS FIREPLACE

INSTALLATION AND OPERATING INSTRUCTIONS

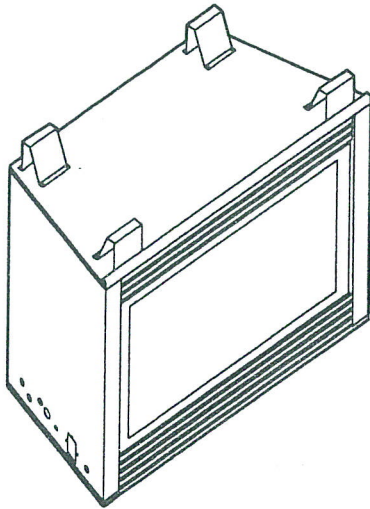

GDVR36 / GDVR42

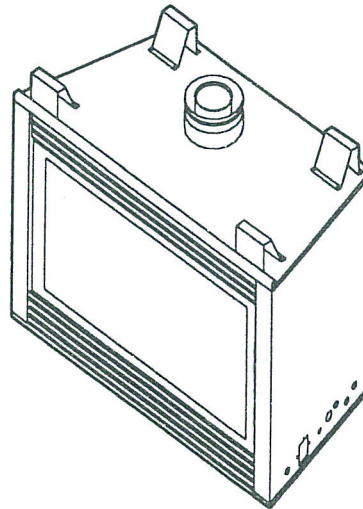

GDVT36 / GDVT42

FOR YOUR SAFETY

Do not store or use gasoline or other flammable vapors and liquids in the vicinity of this or any other appliance.

FOR YOUR SAFETY

WHAT TO DO IF YOU SMELL GAS

- Do not try to light any appliance.
- Do not touch any electrical switch.
- Do not use any phone in your building.
- Immediately call your gas supplier from a neighbor's phone. Follow the gas supplier's instructions.
- If you cannot reach your gas supplier, call the fire department.

WARNING: Improper installation, adjustment, alteration, service or maintenance can cause injury or property damage. Refer to this manual. For assistance or additional information consult a qualified installer, service agency or the gas supplier.

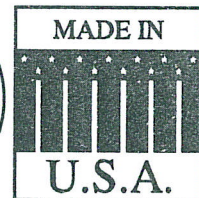
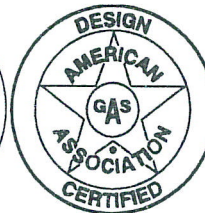

DUE TO HIGH TEMPERATURES, THE APPLIANCE SHOULD BE LOCATED OUT OF TRAFFIC AND AWAY FROM FURNITURE AND DRAPERIES.

CHILDREN AND ADULTS SHOULD BE ALERTED TO THE HAZARDS OF HIGH SURFACE TEMPERATURE AND SHOULD STAY AWAY TO AVOID BURNS OR CLOTHING IGNITION.

YOUNG CHILDREN SHOULD BE CAREFULLY SUPERVISED WHEN THEY ARE IN THE SAME ROOM AS THE APPLIANCE.

CLOTHING OR OTHER FLAMMABLE MATERIAL SHOULD NOT BE PLACED ON OR NEAR THE APPLIANCE.

• READ AND SAVE THESE INSTRUCTIONS •



TABLE OF CONTENTS

Important Safety Information	2
Product / Feature Specifications	3
Product Features	3
Listing & Code Approvals	3
Fireplace Dimensions	5
Pre-Installation Information	6
Before You Start	6
Items Required for Installation	6
Fireplace Locations	6
Clearance Requirements	7
Framing	9
Final Finishing	10
Step by Step Installation	11
Positioning the Fireplace	11
Venting	12
Installing Vent Components	18
Gas Line	21
Electrical Wiring	23
Finishing	25
Final Installation	26
Glass Removal	26
Rock Wool Placement	27
Log Placement	28
Lava Rock & Ember Chunk Placement	29
Operating Instructions	30
Maintenance Instructions	32
Parts List / Illustrations	34
Troubleshooting	38
Warranty Registration	39
Warranty	40

IMPORTANT SAFETY INFORMATION

INSTALLER: Please leave these instructions with the owner.

OWNER: Please read and retain these instructions for future reference.

IMPORTANT: Read these instructions carefully before installing or trying to operate this appliance.

1. **CARBON MONOXIDE POISONING:** Early signs of carbon monoxide poisoning are similar to the flu with headaches, dizziness and/or nausea. If you have these signs, obtain fresh air immediately. Have the appliance serviced as it may not be operating properly.
2. The installation must conform with local codes, or in the absence of local codes, with the National Fuel Gas Code, ANSI Z223.1 (in the United States) or with the current installation code CAN/CGA - B149 (in Canada).
3. This unit complies with ANSI Z21.50-97, CGA 2.22-97 for the Decorative Models (GDV).
4. Installation and repair should be done by a qualified service person.
5. To prevent malfunction and/or sooting, this appliance should be inspected before use and at least annually by a professional service person. It is imperative that control compartments, burners and circulating air passageways of the appliance be kept clean. Refer to MAINTENANCE section found in this manual.
6. Children and adults should be alerted to the hazard of high surface temperature and should stay away to avoid burns or clothing ignition.
7. Young children should be carefully supervised when they are in the same room with the appliance.
8. Do not place clothing or other flammable materials near the fireplace when it is in use.
9. Keep the room area clear and free from combustible materials, gasoline, and other flammable vapors and liquids.
10. During manufacturing, fabricating, and shipping, various components of this appliance are treated with certain oils, film, or bonding agents. These chemicals are not harmful but may produce annoying smoke and smells as they are burned off during the initial operation of the appliance; possibly causing headaches or eye and lung irritation. This is a normal and temporary occurrence. The initial break-in operation should last 2-3 hours with the burner at the highest setting. Provide maximum ventilation by opening windows and doors to allow odors to dissipate with continued use.
11. Input ratings are shown in BTU per hour and are for elevations up to 2000 feet. For elevations above 2000 feet, input ratings should be reduced 10 percent.
12. The appliance and its individual shutoff valve must be disconnected from the gas supply piping system during any pressure testing of that system at test pressures in excess of 1/2 psig (3.5 kPa).
13. The appliance must be isolated from the gas supply piping system by closing its individual manual shutoff valve during any pressure testing of the gas supply piping system at test pressures equal to or less than 1/2 psig (3.5 kPa).
14. Do not use this appliance if any part has been under water. Immediately call a qualified service technician to inspect the appliance and to replace any part of the control system and any gas control which has been under water.
15. Due to high temperatures, the appliance should be located out of traffic and away from furniture and draperies.
16. This appliance must not be connected to a chimney flue(s) servicing a separate solid fuel burning appliance or any other appliances.
17. This appliance is a vented gas appliance. Do NOT burn wood or other material in this appliance.
18. Provide adequate clearances around air openings and adequate accessibility clearance for servicing and operation. NEVER obstruct front opening of the appliance.
19. Any safety screen or guard (i.e. glass door) removed for servicing an appliance should be replaced prior to operating the appliance.
20. This appliance must be installed on a metal or wood plate extending the full width and depth of the unit if the unit is to be installed on carpet, vinyl tile or any combustible other than wood.
21. These units MUST use one of the vent systems described in the venting system of this manual. NO other vent systems or components may be used.
22. Do not operate the appliance with the glass door removed, cracked, or broken. Replacement of the glass door should be done by a licensed or qualified person. Do not strike or slam the door. The glass door assembly should only be replaced as a complete unit supplied by manufacturer. NO substitute materials should be used.
23. Do not use abrasive cleaners on the glass door assembly. Do not clean glass door when it is hot.
24. Venting terminals shall not be recessed into a wall or siding.

PRODUCT / FEATURE SPECIFICATIONS

PRODUCT FEATURES

Natural Gas

Gas Inlet Pressure:

Maximum: 10.5" w.c.

Minimum Gas Supply Pressure for the Purpose of Input Adjustment: 4.5" w.c.

Model Numbers, Control Type, and Gas Rate:

<u>DECORATIVE UNITS</u>		
Model No.	Type	Gas Rate Max BTU/Hr
GDVR36NV	Milli-Volt	27,000
GDVT36NV	Milli-Volt	27,000
GDVR42NV	Milli-Volt	28,000
GDVT42NV	Milli-Volt	28,000

Gas rate shown above is for altitudes up to 2000 ft. Rate should be reduced 10% above 2000 ft.

Propane / LPG

Gas Inlet Pressure:

Maximum: 13" w.c.

Minimum Gas Supply Pressure for the Purpose of Input Adjustment: 11" w.c.

Model Numbers, Control Type, and Gas Rate:

<u>DECORATIVE UNITS</u>		
Model No.	Type	Gas Rate Max BTU/Hr
GDVR36PV	Milli-Volt	27,000
GDVT36PV	Milli-Volt	27,000
GDVR42PV	Milli-Volt	28,000
GDVT42PV	Milli-Volt	28,000

Gas rate shown above is for altitudes up to 2000 ft. Rate should be reduced 10% above 2000 ft.

PRODUCT / FEATURE SPECIFICATIONS

Ignition: Piezo ignitor allows ignition of the pilot without the use of matches or batteries.

Controls: Milli-Volt has three (3) positions:

- OFF** All gas is shut off at valve.
- PILOT** Valve position to light / maintain a standing pilot.
- ON** Valve position for operation of unit via switch (RS-ON-OFF) on front of unit.

Switch: Switch has three (3) positions:

- RS** On position for a remote switch to turn appliance on (i.e. wall switch).
- OFF** Off position of switch to turn appliance off.
- ON** On position of switch to turn appliance on.

NOTE: Wall Switch should be pre-wired at installation to avoid costly reconstruction.

Logs: Set of five (5) ceramic fiber logs and grate. Consult "Log Placement" in FINAL ASSEMBLY section of this manual or decal on log box for proper positioning of logs.

Glass Front: One piece glass door assembly. The decorative model use tempered glass, and the AFUE models use ceramic glass.

Venting: Coaxial (5" flue & 8" inlet) Simpson Duravent interlocking Direct Vent System.

Fan / Blower: Optional installation. Junction box provided as standard.

NOTE: Blower Switch should be pre-wired at installation to avoid costly reconstruction.

Optional Accessories: See accessory list PARTS LIST / ILLUSTRATION section.

LISTING & CODE APPROVALS

These models have been tested and certified by the applicable laboratories to the standards listed below.

MODEL	LABORATORY	TYPE	STANDARD
GDVR36/42	A.G.A./CGA	Direct Vent Decorative	ANSI Z21.50-96 • CGA 2.22-96
GDVT36/42	A.G.A./CGA	Direct Vent Decorative	ANSI Z21.50-96 • CGA 2.22-96

NOTE

In addition, these models are tested and certified for use in aftermarket manufactured home and mobile home installation.

FIREPLACE DIMENSIONS

GDVR Series

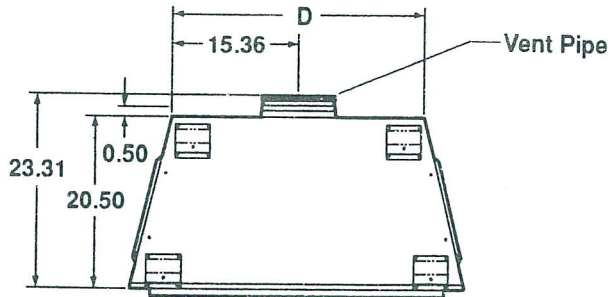

NOTE: Common dimensions between rear and top vent are shown on rear vent only.

	GDV36	GDV42
A	30.63	38.63
B	36.00	42.00
C	41.00	47.00
D	30.83	36.83

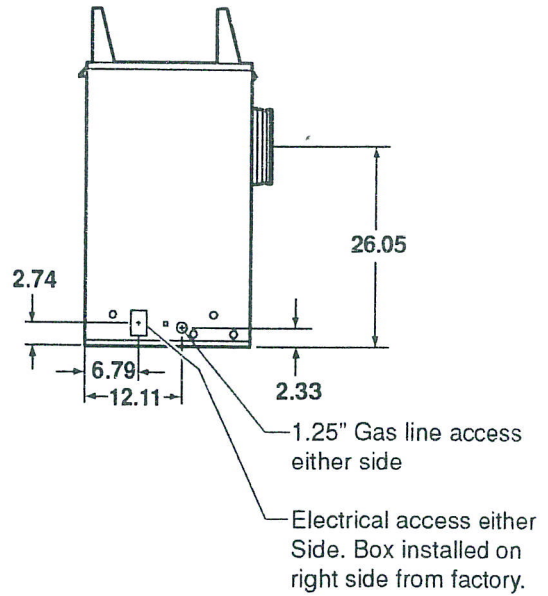
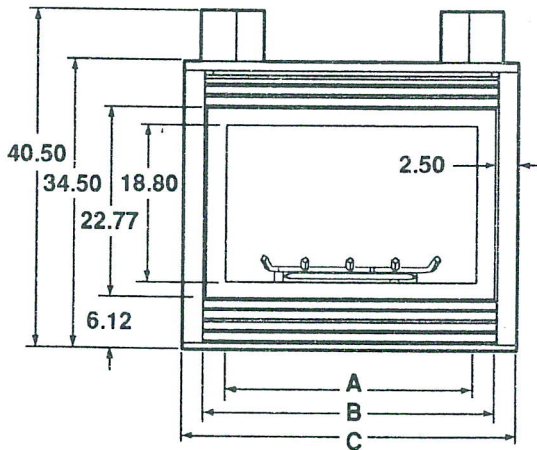

GDVT Series

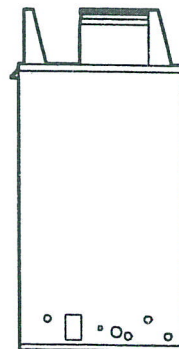
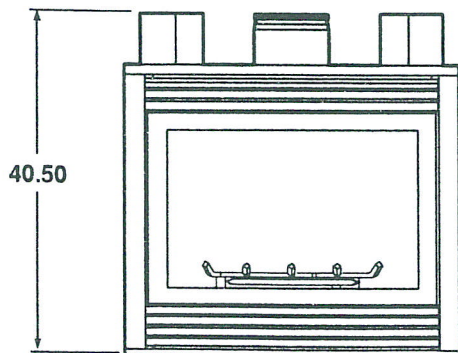
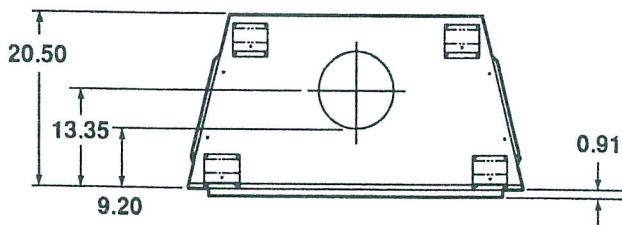

Figure 1: Fireplace Dimensions

PRE-INSTALLATION INFORMATION

BEFORE YOU START:

Read this manual thoroughly and follow all instructions carefully.

Check that all parts have been received. This Direct Vent Appliance consists of the following:

- Gas Appliance (including firebox, glass door, & logs)
- Venting System (including 5x8 pipe, firestops, wall hangers, & termination)

Inspect all contents for shipping damage and immediately inform your dealer if any damage is found. Plan for the installation of your appliance. This includes determining where the unit is to be installed, the vent configuration to be used, framing and finishing details, and whether any optional accessories (i.e. fan, wall switch, or remote control) are desired. Consult your local building code agency to ensure compliance with local codes, including permits and inspections.

NOTE

Illustrations shown in this manual reflect “typical” installations with nominal dimensions and are design and framing reference only. Actual installations may vary due to individual design preferences. However, always maintain at least minimum clearances to combustible materials and do not violate any specific installation requirements.

ITEMS REQUIRED FOR INSTALLATION:

TOOLS:

Phillips Screwdriver
Hammer
Saw and / or saber saw
Level
Measuring Tape
Electric Drill and Bits
Pliers
Square
Pipe Wrench

BUILDING SUPPLIES:

Framing Materials
Wall Finishing Materials
Caulking Material (Noncombustible)
Fireplace Surround Material (Noncombustible)
Piping Complying with Local Codes
Tee Joint
Pipe Sealant Approved for use with Propane/LPG
(Resistant to Sulfur Compounds)

FIREPLACE LOCATIONS:

Carefully select the best location for installation of your fireplace. The following factors should be taken into consideration:

- Clearance to side wall, ceiling, woodwork, and windows. Refer to CLEARANCE REQUIREMENTS section found in this manual. Minimum clearances to combustibles must be maintained.
- This fireplace may be installed along a wall, across a corner, or use an exterior chase. Refer to Figure 2 for suggested locations.
- Location should be out of high traffic areas and away from furniture and draperies due to heat from appliance.
- Never obstruct the front opening of the fireplace.
- Do not install in the vicinity where gasoline or other flammable liquids may be stored.
- Vent pipe routing. Refer to VENTING section found in this manual for allowable venting configurations.
- These units can be installed in a bedroom. Refer to National Fuel Gas Code ANSI Z223.1/NFPA 54 - (current edition), the Uniform Mechanical Code - (current edition), and Local Building Codes for specific installation requirements.

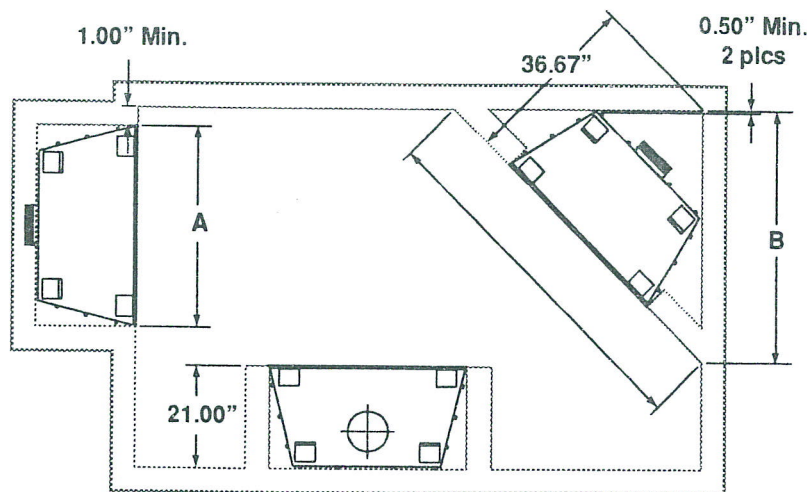

	GDV36	GDV42
A	42.00	48.00
B	51.88	57.88
C	73.38	79.38

Figure 2: Fireplace Locations and Clearance Requirements

CLEARANCE REQUIREMENTS

1. Ensure that minimum clearances shown in Figures 3 and 4 are maintained. Left and right clearances are determined when facing the front of the appliance.
2. Follow these instructions carefully to ensure safe installation. Failure to follow these requirements may create a fire hazard.

SIDEWALL CLEARANCES: The clearance from the front edge of the appliance to any combustible wall should not be less than 1" on the left side and 15" on the right side, or not less than 1" on the right side and 15" on the left side. Refer to Figure 3.

CEILING CLEARANCE: The ceiling must be at least 31" from the top of the front of the fireplace (65.5" from the bottom of the appliance). Refer to Figure 3

BACKWALL CLEARANCE: The appliance may be placed against a combustible back wall. *NOTE: There are 1/2" spacers on the outer shell of the unit to maintain minimum clearance of the outer shell to combustibles.*

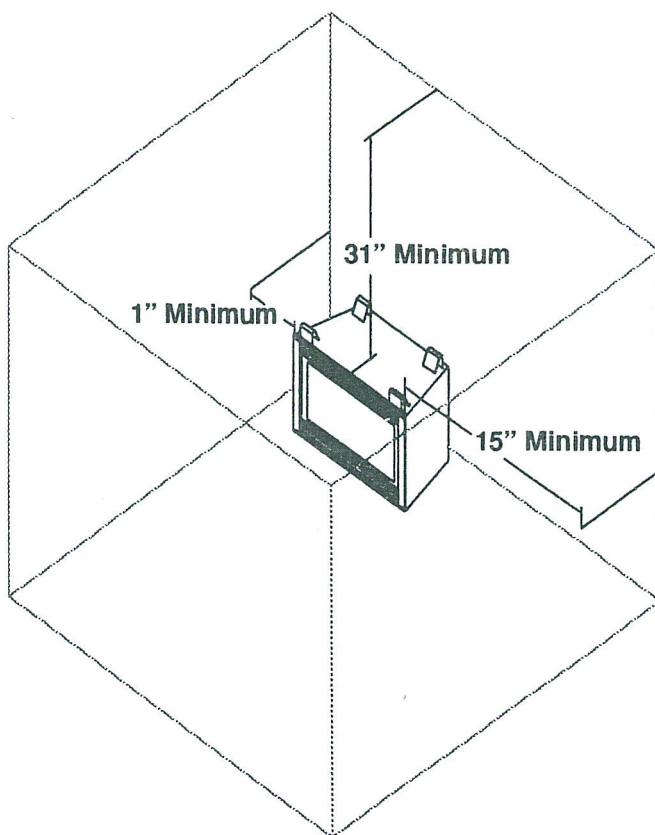

Figure 3: Wall & Ceiling Clearances

PRE-INSTALLATION INFORMATION

COMBUSTIBLE CLEARANCES: The appliance is a zero clearance fireplace with spacers defining the minimum space to the sheet metal outer shell. Combustibles may be placed up against these spacers. Do NOT place combustibles closer than allowed by the spacers or a fire hazard may exist. The spacers for the sides and rear of the appliance are 1/2" and the top spacers are 6 1/2". On the front top edge in front of the top framing spacers, a combustible wall (or drywall) may be brought up to the top edge of the unit (see Figure 4).

MANTEL CLEARANCES: A canopy comes with some units. It MUST be installed. If a combustible mantel is installed, it must meet the clearance requirements detailed in Figure 4.

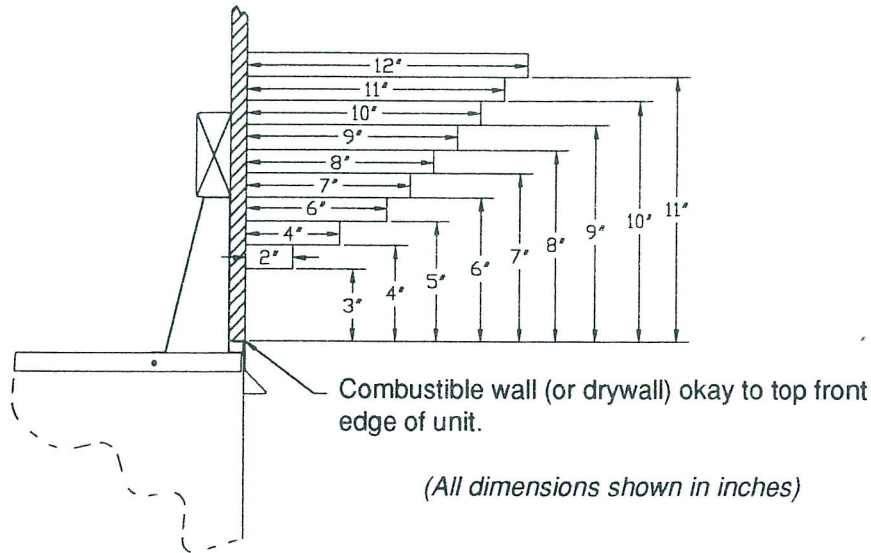

Figure 4: Mantel Clearances

FLOOR CLEARANCE: The fireplace may be installed on a flat, hard combustible surface (i.e. flat wood, plywood, or particle board). Be sure that the fireplace rests on a solid continuous floor of platform with appropriate framing support. Do NOT install appliance directly on carpeting, vinyl, or other soft floor covering.

MINIMUM VENT CLEARANCES: The minimum clearances to combustibles for vent pipe require 3 inches at the top and 1 inch at the sides and bottom for horizontal sections of the vent system (see Figure 5). For vertical sections of vent pipe a 1 inch minimum clearance all around the pipe must be maintained.

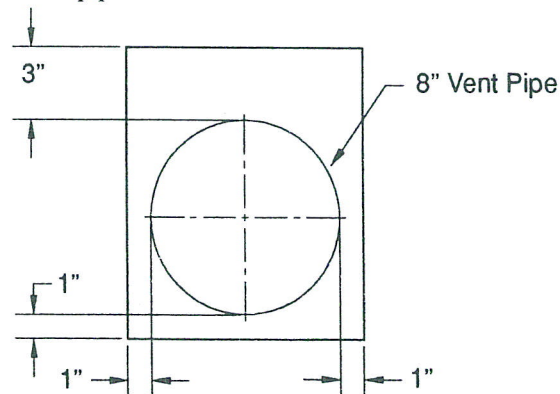

Figure 5: Combustible Clearance for Horizontal Venting

FRAMING

Firebox framing can be built before or after the appliance is set in place. Framing should be positioned to accommodate wall covering and fireplace facing mantel. Figure 6 shows a typical framing of this appliance. Refer to Figure 1 for firebox dimensions. All minimum clearances must be maintained in framing the appliance. The framing headers may rest on the top of the framing spacers.

CAUTION

Measure fireplace dimensions and verify framing methods & wall covering details BEFORE framing construction begins.

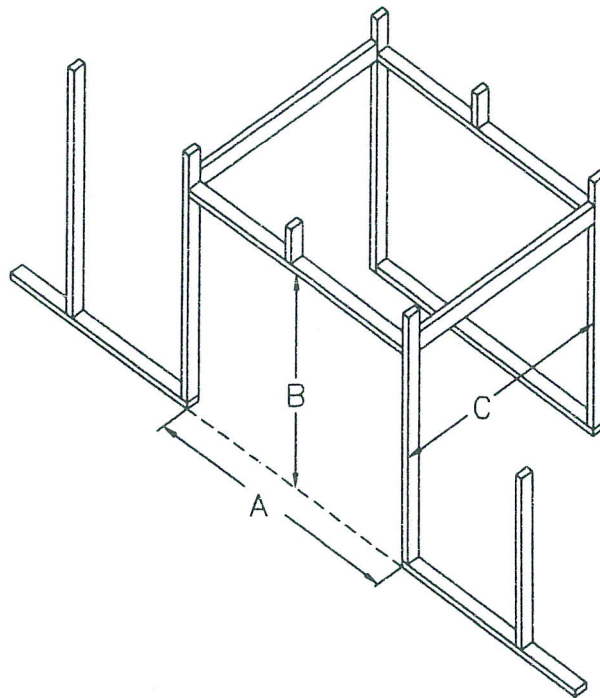

	A	B	C
GDV36	42.00"	40.50"	21.00"
GDV36	48.00"	40.50"	21.00"

Figure 6: Framing Dimensions

PRE-INSTALLATION INFORMATION

FINAL FINISHING

Note: Any remote wiring (i.e. remote control, wall switch, optional fan) must be done prior to final finishing to avoid costly reconstruction.

WARNING

Never obstruct or modify the air inlet/outlet grills in any manner, as it may create a fire hazard.

Only noncombustible materials (i.e. brick, tile, slate, steel, or other materials with a U.L. fire rating of Zero) may be used to cover the black surface of the appliance. A 300°F minimum adhesive may be used to attach facing materials to the black surface. If joints between the finished wall and the fireplace surround are sealed, a 300°F minimum sealant material (General Electric RTV103 or equivalent) must be used. Refer to Figure 7.

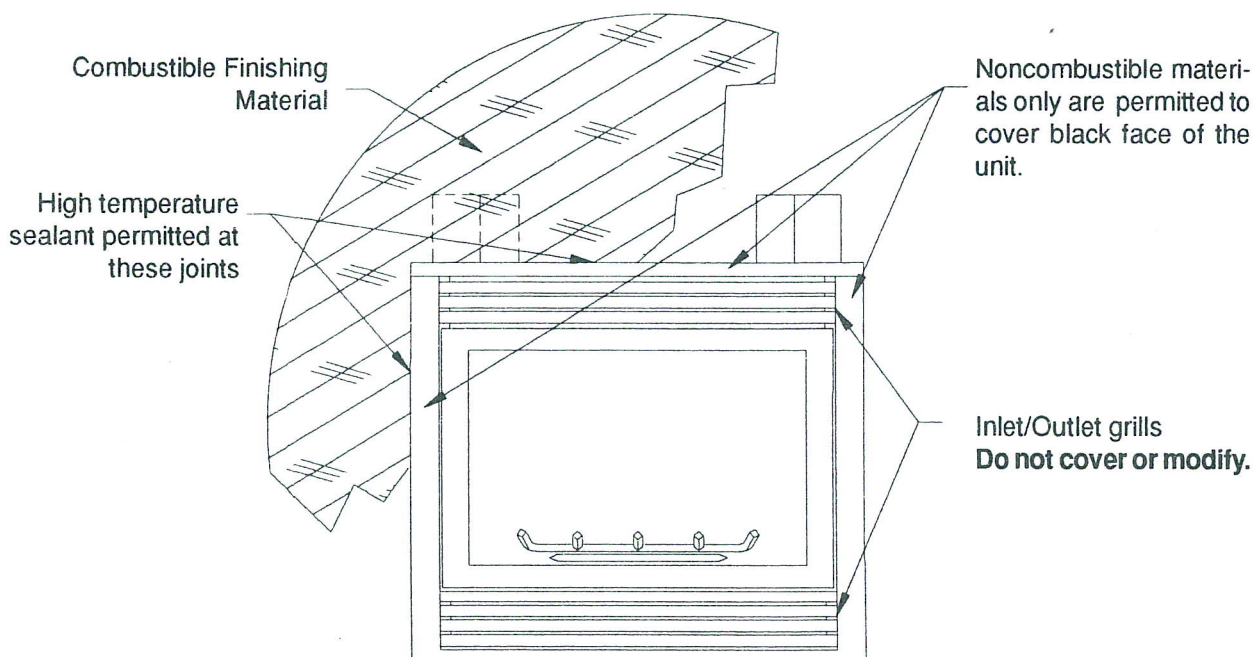

Figure 7: Finishing Materials

POSITIONING THE FIREPLACE

Note: The fireplace must be installed giving full consideration to the clearance and height requirements identified in this manual.

- Step 1.** Attach the nailing flanges provided to the sides of the appliance. The flanges are slotted to accommodate various wall thickness. Measure wall thickness and tighten nailing flange to the appropriate dimension.
- Step 2.** Slide the firebox into prepared framing or position firebox in its final position and frame later. Be sure appliance is on a flat surface.
- Step 3.** Level the firebox by checking the top of unit. Shim side-to-side and front-to-back as necessary.
- Step 4.** Anchor firebox to the side framing members using 8d nails or other suitable fasteners. Refer to Figure 8 below.

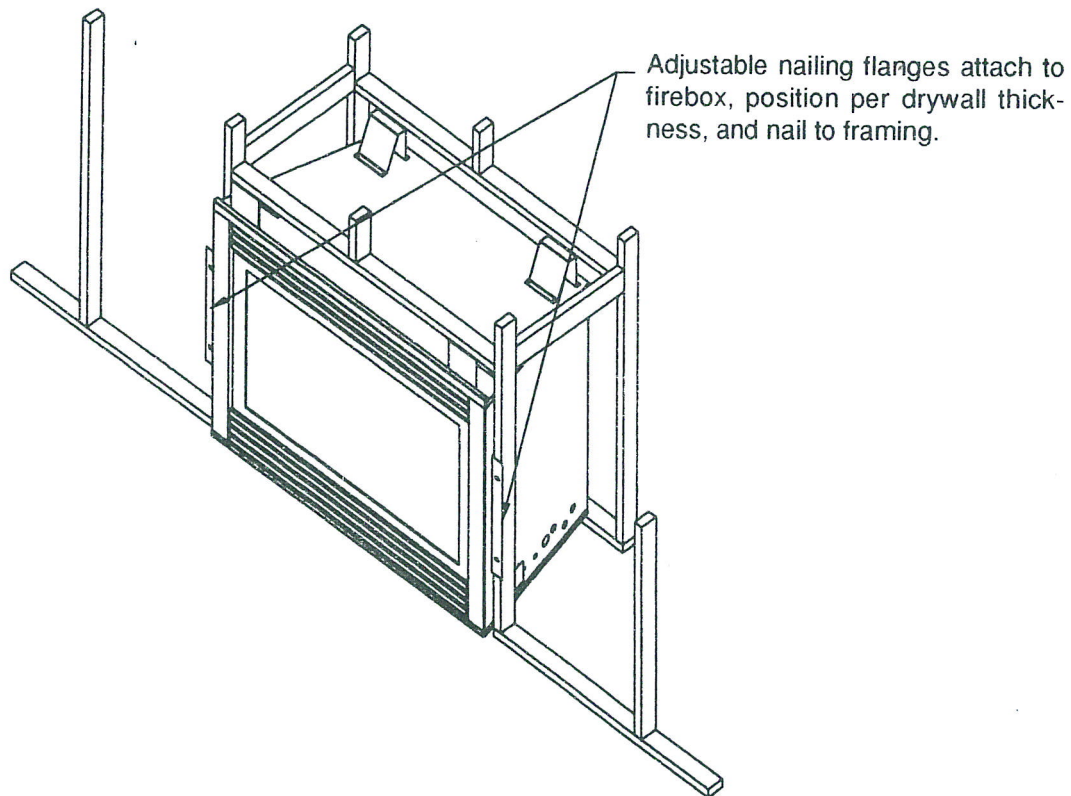

Figure 8: Positioning the Fireplace

STEP-BY-STEP INSTALLATION

VENTING

GENERAL RULES

1. These models are approved to use Simpson-Duravent 5X8 Direct Vent Pipe Components. **NO OTHER VENTING SYSTEMS OR COMPONENTS MAY BE USED.**
See PARTS LIST / ILLUSTRATIONS section for a list of approved vent components.
2. **ALWAYS MAINTAIN MINIMUM CLEARANCES AROUND VENT SYSTEM** as shown in this manual. **DO NOT** pack the open air spaces with insulation or other materials.
3. Common venting of this gas appliance with other gas appliances is not allowed.
4. This appliance must not be connected to a chimney flue servicing a separate solid fuel burning appliance.
5. Two 45° elbows (P/N 1245) may be used in place of one 90° elbow (P/N 1290).
6. Wall & Ceiling Firestops (P/N 1242 & 1263) must be used when going through walls & ceilings.
7. Detailed installation instructions are included with each vent termination and must be used in conjunction with this manual.

HORIZONTAL TERMINATION

1. Horizontal vent caps (terminations) can terminate as prescribed in Figure 9. **ALWAYS** maintain the minimum clearances shown in this figure.
2. Any horizontal run must have a 1/4" rise for every 1 foot of run towards the vent termination. Never allow the vent to run downward. This could cause high temperatures and may present a fire hazard.
3. Support vertical runs of pipe with wall strap (P/N 1288). Maximum unsupported vertical rise is 8 feet.
4. Horizontal runs require the use of one wall strap (P/N 1288) for every 3 feet of pipe.
5. A maximum of three 90° elbows may be used.
6. The maximum horizontal runs shown in this manual are for one or two 90° elbows. If other elbows are used the maximum horizontal run is reduced by 5 feet per additional elbow.
7. For buildings with vinyl sidings, a Vinyl Siding Standoff (P/N 1250) should be used for horizontal termination applications.
8. Horizontal Termination Conditions are shown in Figures 10-12

REAR VENT (GDVR36/42)

- Straight horizontal venting shown in Figure 10.
- Straight venting with 45° elbow shown in Figure 10.
(Note: for other case than what is shown, use two 90° elbows)
- Horizontal Venting with two elbow 90° shown in Figure 11

TOP VENT (GDVT36/42)

- 90° Elbow off the top of the unit can have a maximum 24" horizontal pipe section. (2 1/2' from centerline of vertical pipe to termination). Refer to Figure 12, V=4'.
- Horizontal Venting with one 90° elbow shown in Figure 12.

STEP-BY-STEP INSTALLATION

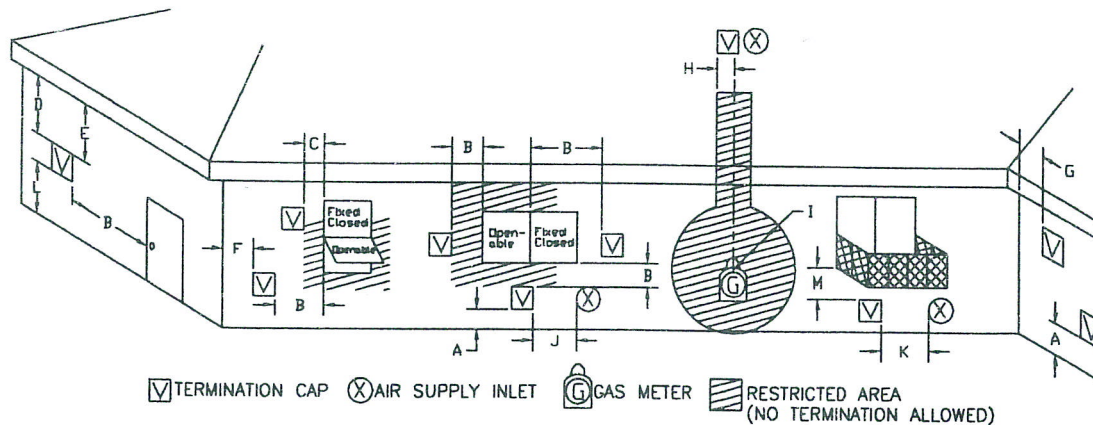

A=12 inches	Clearance above the ground, a veranda, porch, deck, or balcony	L+=7 feet	Clearance above a paved sidewalk paved driveway located on public property
B=12 inches	Clearance to window or door that may be opened.	M~=12 inches	Clearance under veranda, porch, deck, or balcony.
C=9 inches	Clearance to permanently closed window. 12 inches (Canada)	*	Distance required for vinyl soffit materials - 30 inches
D*=18 inches	Vertical clearance to ventilated soffit located above the terminal Note: Local codes or within a horizontal distance of 2 feet from the centerline of the terminal.	^	As specified in Installation Codes, regulations may require different clearances.
E*=18 inches	Clearance to a ventilated soffit.	#	As specified in CGA B149 Installation Codes. Note: Local codes or regulations may require different clearances
F=9 inches	Clearance to an outside corner.		
G=6 inches	Clearance to an inside corner.		
H^=3 feet	Not to be installed above a meter/regulator assembly within 3 ft horizontally from the centerline of the regulator.	+	A vent must not terminate directly above a sidewalk or paved driveway which is located between two single family dwellings and serves both dwellings.
I#=3 feet	Clearance to service regulator vent outlet. 6 feet (Canada)		
J=12 inches	Clearance to non-mechanical air supply inlet to building or the combustion air inlet to any other appliance.	~	Only permitted if veranda, porch, deck, or balcony is fully open on minimum of 2 sides beneath the floor.
K^=6 feet	Clearance to a mechanical air supply inlet may require different clearances.		

Figure 9: Vent Termination Minimum Clearances

STEP-BY-STEP INSTALLATION

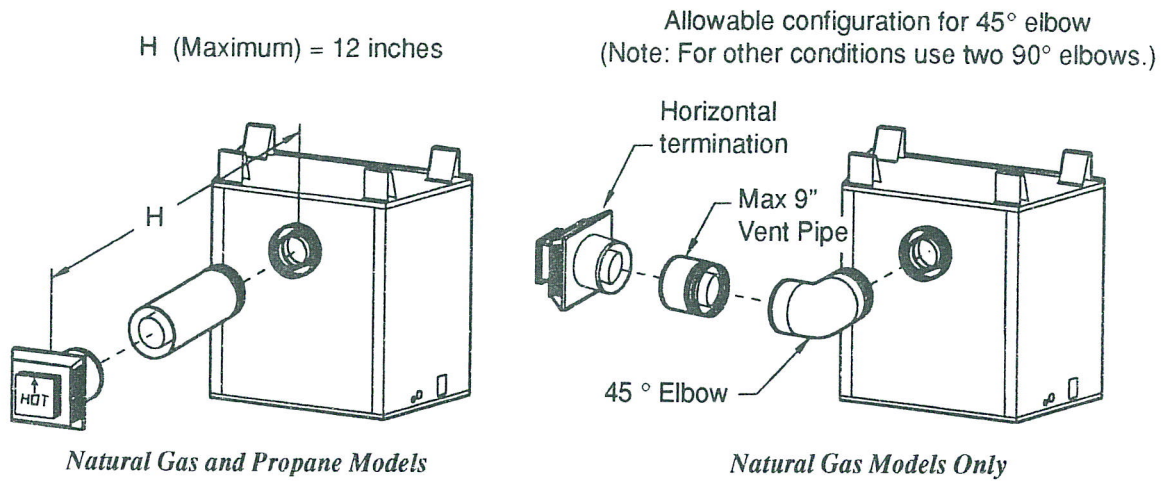

Figure 10: Maximum Allowable Horizontal Venting Straight Out the Back of the Unit

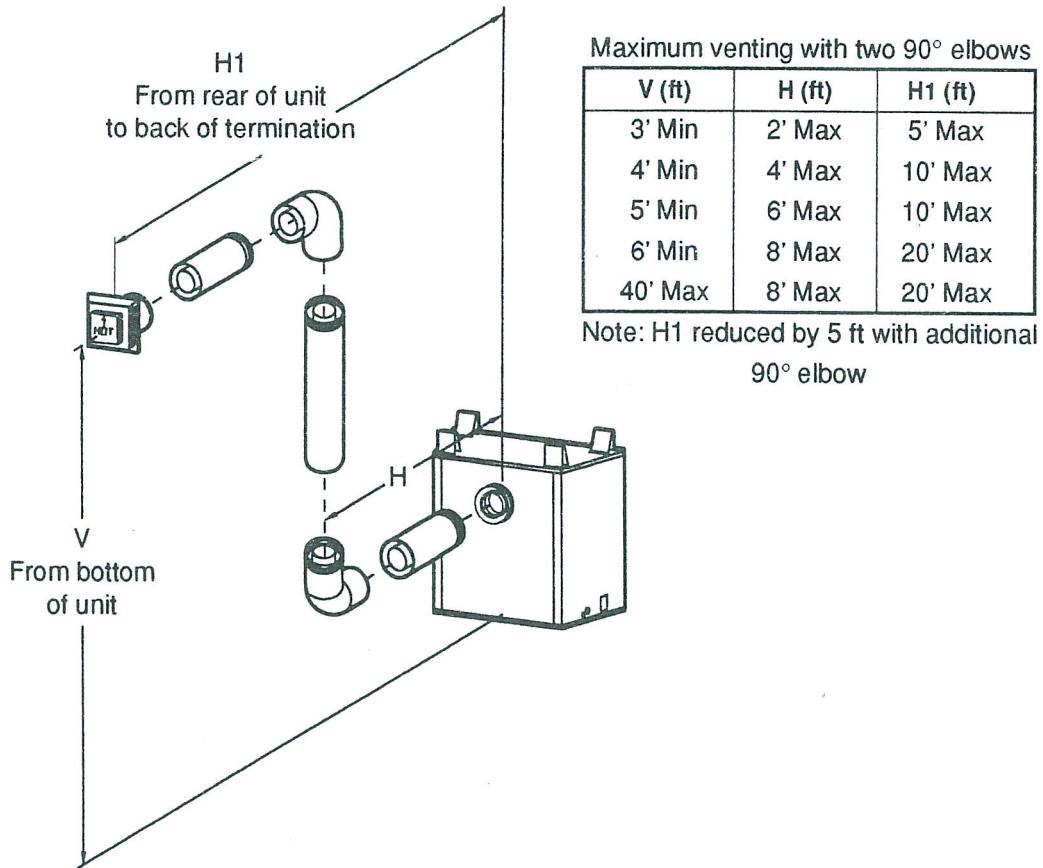
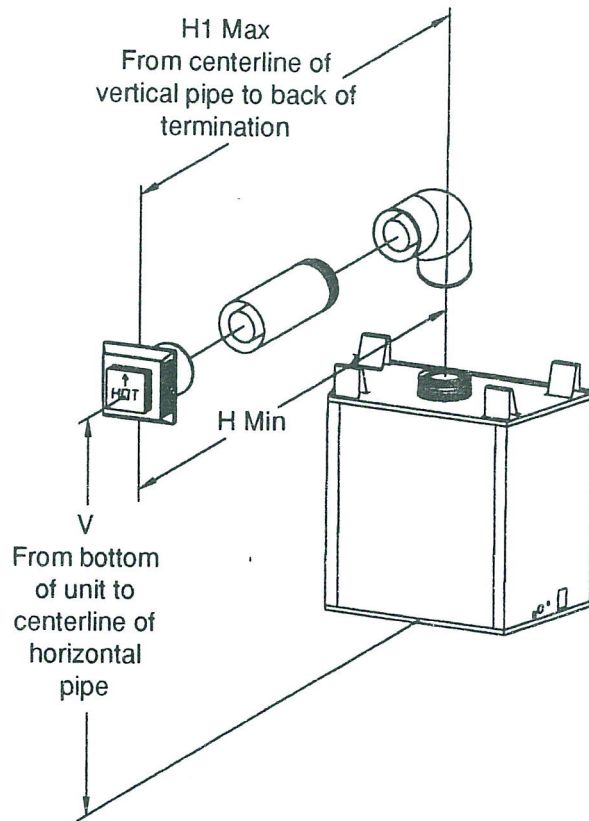

Figure 11: Rear Vent (GDVR) Maximum Allowable Horizontal Venting Using Two 90° Elbows

STEP-BY-STEP INSTALLATION



Maximum venting with one 90° elbow

Gas Type	V (ft)	H Min (ft)	H1 Max (ft)
Natural Gas Only	4' Min	1' Max	2.5' Max
Natural Gas and Propane Gas	5' Min	1' Max	2.5' Max
	6' Min	1' Max	20' Max
	30' Min	1' Max	20' Max

Note: H1 reduced by 5 ft per additional 90° elbow maximum of three allowed.

Figure 12: Top Vent (GDVT) Maximum Allowable Horizontal Venting Using One 90° Elbow

VERTICAL TERMINATION

1. Plan your vertical installation. Major building codes specify a minimum vent height above the roof top depending on the pitch of the roof. Refer to Figure 13 for minimum chimney heights. Trees, buildings, adjoining roof lines, & adverse wind conditions may require taller chimneys than what is shown in Figure 13.
2. ALWAYS maintain minimum clearance to combustibles. Do not pack air spaces with insulation or other material.
3. Support vertical runs of pipe with wall strap (P/N 1288). Maximum unsupported vertical rise is 8 feet.
4. Any horizontal run must have a 1/4" rise for every 1 foot of run towards the vent termination. Never allow the vent to run downward. This could cause high temperatures and may present a fire hazard.
5. Horizontal runs require the use of one wall strap (P/N 1288) for every 3 feet of pipe.
6. A maximum of three 90° elbows may be used.
7. The maximum horizontal runs shown in this manual are for one or two 90° elbows. If additional elbows are used the maximum horizontal run is reduced by 5 feet per additional elbow.
8. Vertical Termination Conditions are shown in Figures 14-15.

STEP-BY-STEP INSTALLATION

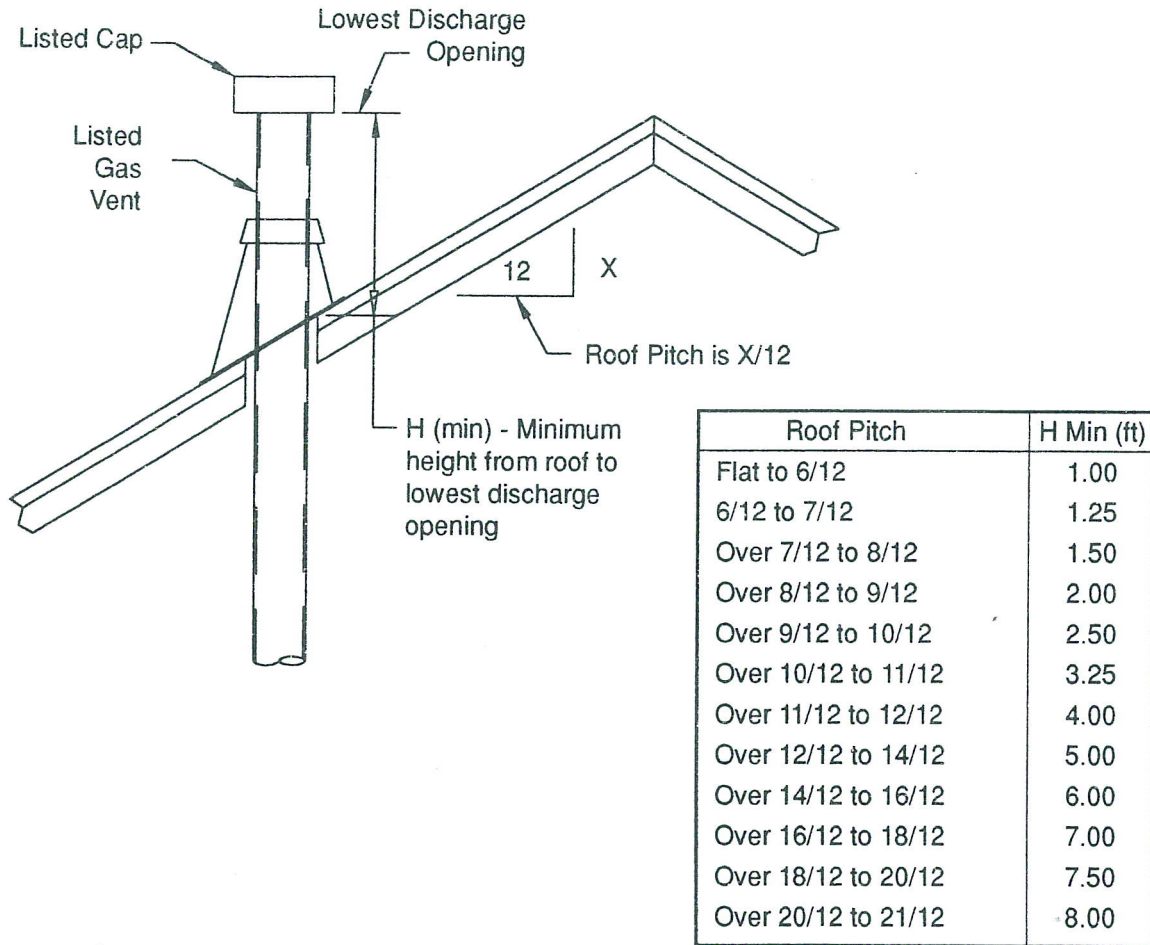

Figure 13: Minimum Vent Height for Various Roof Pitches

REAR VENT (GDVR36/42)

- Vertical Venting with 90° elbow shown in Figure 14.
- Vertical Venting with three 90° elbows is also shown in Figure 14.

TOP VENT (GDVT36/42)

- Straight Vertical Venting from the top of the unit is shown in Figure 15.
- NOTE: The maximum straight vertical vent is 40 feet.
- Vertical Venting with two 90° elbows is also shown in Figure 15.
- Although unit is tested to conditions shown in Figure 15, for better performance it is recommended to use 2 feet of vertical rise for every 1 foot of horizontal run in vertical termination conditions.

STEP-BY-STEP INSTALLATION

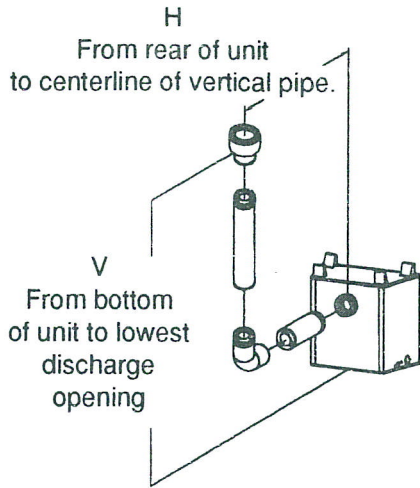

Maximum venting with one 90° elbow

V (ft)	H (ft)
3' Min	2' Max
4' Min	4' Max
5' Min	6' Max
6' Min	8' Max
40' Max	8' Max

Note: H reduced by 5 ft with additional 90° elbow (Maximum of three 90° elbows allowed)

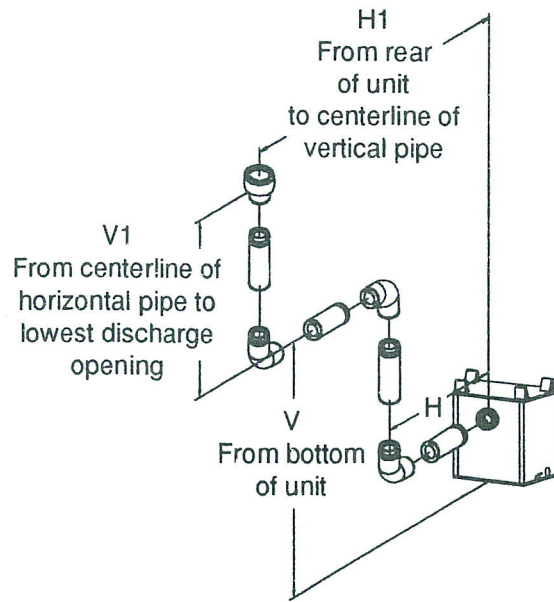

Maximum venting with two 90° elbow

V (ft)	V+V1 (ft)	H	H1 (ft)
3' Min	40' Max	2' Max	5' Max
4' Min	40' Max	4' Max	10' Max
5' Min	40' Max	6' Max	15' Max
6' Min	40' Max	8' Max	20' Max
40' Max	40' Max	8' Max	20' Max

Note: (V + V1) Maximum allowable is 40 ft

Figure 14: Rear Vent (GDVR) Maximum Allowable Vertical Venting

V (minimum) = 12 feet
V (maximum) = 40 feet

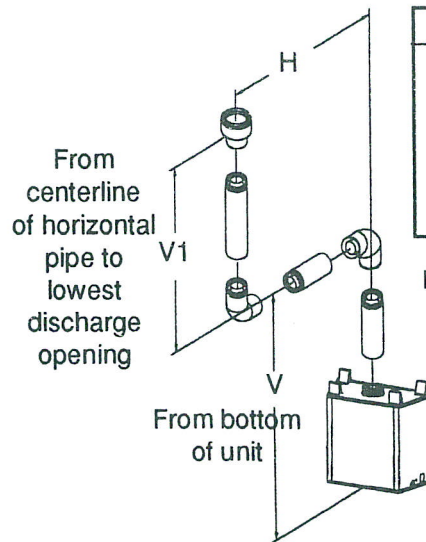
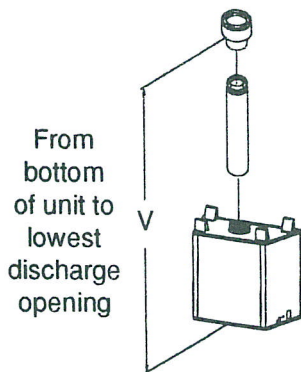

Maximum venting with two 90° elbow

V (ft)	V+V1 Min (ft)	H1 Max (ft)
4' Min	40' Max	2.5' Max
5' Min	40' Max	3' Max
6' Min	40' Max	3.5' Max
7' Min	40' Max	4' Max
8' Min	40' Max	20' Max
40' Min	40' Max	20' Max

Note: (V+V1) Maximum allowable is 40 ft
Note: H is reduced by 5 ft for an additional 90° elbow maximum of three allowed.

Figure 15: Top Vent (GDVT) Maximum Allowable Vertical Venting

STEP-BY-STEP INSTALLATION

INSTALLING VENT COMPONENTS

1. Plan your installation. Set unit in place and survey how best to vent the unit. Select the appropriate pipe for the installation.
2. Read this manual and the manual with the termination cap thoroughly before installing unit or vent system.
3. After vent configuration has been decided, begin attaching pipe to unit.
 - All vent pipe lock into place by sliding the pipe sections together. Nest the four indentations on the female end of one pipe into the slots of the other pipe and then twist the pipe together (See Manual that comes with termination for more detailed instructions).
 - All elbows install the same as the pipe. They may be rotated to any angle desirable.
4. Continue to add vent components. Be certain that each section is properly.
5. Where necessary add support brackets. Refer to Figure 16.
 - Horizontal runs must be supported every 3 feet using wall straps (P/N 1288).
 - Vertical runs must be supported every 8 feet using wall straps (P/N 1288).
 - Slip wall straps loosely on to pipe.
 - Attach straps to framing members using nails or screws.
 - Tighten nut/bolt on strap to secure pipe.

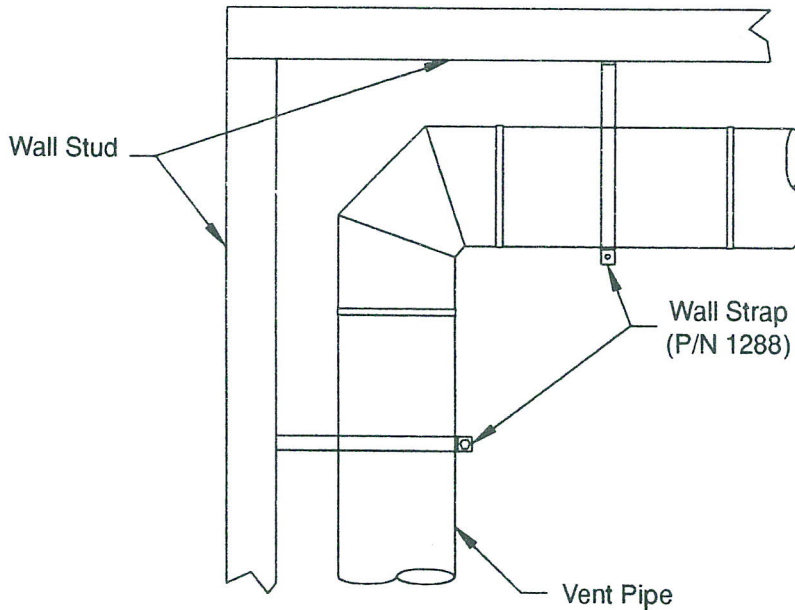

Figure 16: Installing Pipe Supports

WARNING

Any horizontal runs that pass through an exterior or interior wall require use of a wall firestop and any vertical runs that go through a ceiling require the use of a ceiling firestop.

6. A wall firestop (P/N 1242) must be installed if the vent passes through a wall.
 - Cut a 12 inch X 12 inch hole through the wall. The center of the hole is 1 inch above the centerline of the horizontal pipe. See Figure 17.
 - Position firestop in hole and secure with screws or nails.
 - Run vent through firestop.

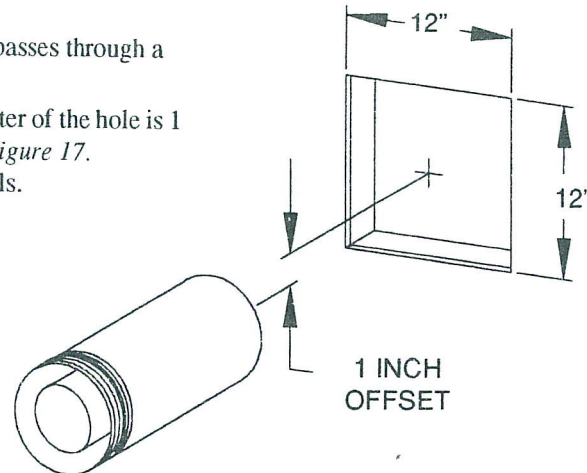

Figure 17: Wall Firestop Hole Location

7. A ceiling firestop (P/N 1263) **MUST BE** installed when the vent goes through ceiling.
 - Position a plumb bob over the center of the vertical pipe which will go through the ceiling.
 - Drill a hole through this centerpoint and check the floor for obstructions (i.e. wiring or plumbing).
 - Reposition the fireplace and vent system, if necessary, to accommodate ceiling joists or obstructions.
 - Cut an 11 inch X 11 inch hole through the ceiling, using the centerpoint.
 - Frame the hole with framing lumber the same size as the ceiling joists. See Figure 18.
 - Position firestop as shown. If attic is above, mount firestop on top of framing. If room is above, mount firestop on the bottom of framing. Secure with nails or screws.
 - Run vent through firestop.

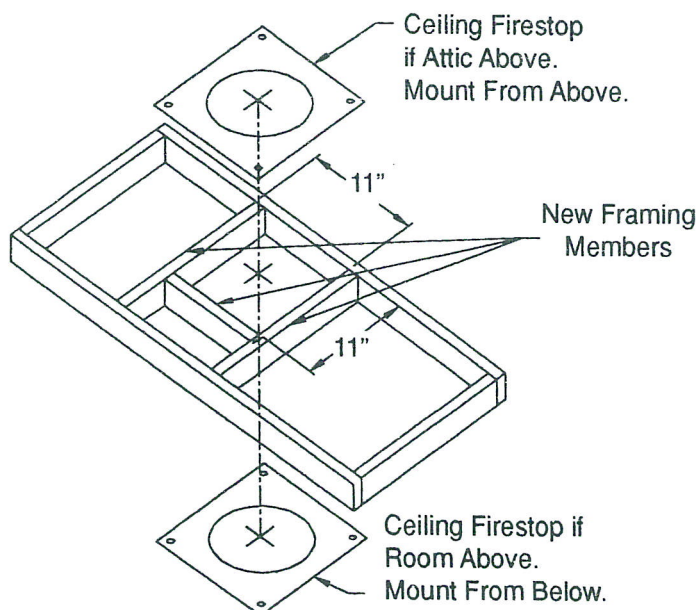

Figure 18: Ceiling Firestop Location

STEP-BY-STEP INSTALLATION

WARNING

Move all insulation around vertical vent pipe to provide a minimum clearance of 1 inch. Move all insulation around horizontal vent pipe to provide a minimum clearance of 3 inches above the pipe, and a minimum clearance of 1 inch below and to the sides of the pipe.

7. Finally attach the termination to the last section of pipe.
 - For horizontal terminations, attach and secure the termination to the last section of pipe. **AT LEAST 1 1/2" OF OVERLAP IS REQUIRED.** Screw the termination to the pipe with three screws.
 - Attach the termination to the exterior wall using the 4 screws provided in the termination box.
 - If the house has vinyl siding, a vinyl siding standoff (P/N 1250) must be used. After making the 12"x12" opening in the wall, cut the vinyl siding so that the standoff can be mounted flush with the siding. Secure the standoff with nails. Finish the edges of the siding with trim or "J channel" to prevent water from leaking into the building. Then attach the termination cap to the standoff.
 - A deflector shield (P/N 28D564) must be installed on all termination caps. Failure to comply may cause sooting or other damage to wall.

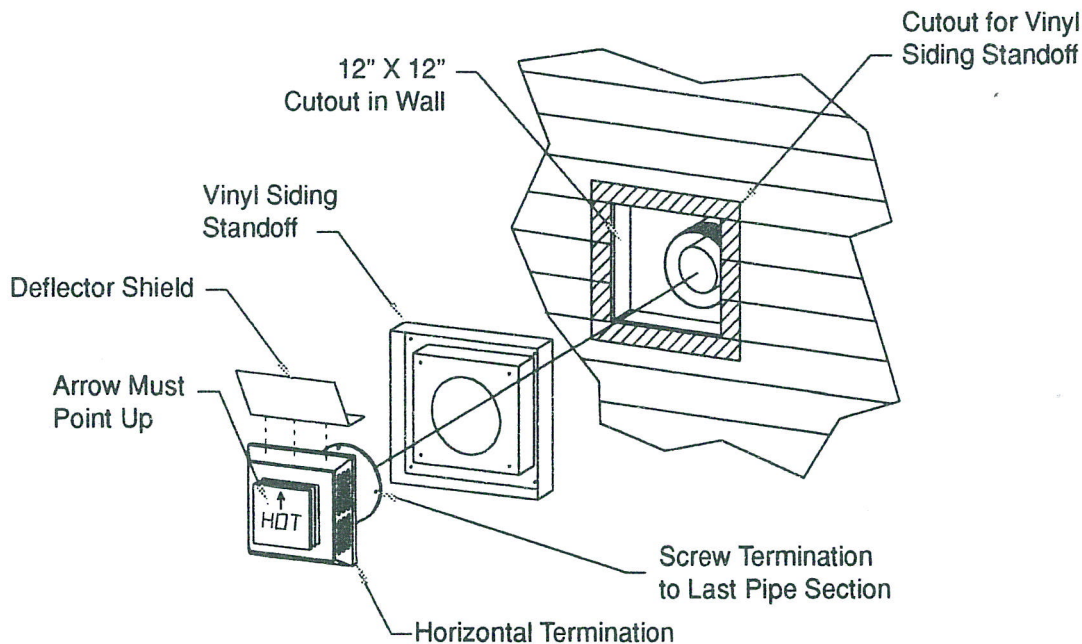

Figure 19: Horizontal Termination Installation on a Vinyl Siding Wall

WARNING

Termination cap must be positioned so that the arrow is pointed up.

- Refer back to Figure 9 for allowable horizontal vent locations.
- If installation requires snorkel termination, follow instructions in snorkel termination box.
- For vertical terminations, locate and mark the vent centerpoint on the underside of the roof and drive a nail through this centerpoint.
- Make an outline of the roof hole around the centerpoint nail. NOTE: The size of the roof hole is depend upon the pitch of the roof. There MUST be at least 1 inch clearance between the vertical vent pipe and any combustible materials.
- Frame the hole in the roof. Refer to the Uniform building Code for roof framing details.
- Install roof flashing and secure in place with nails.

- NOTE: Refer back to Figure 13 for appropriate chimney lengths.
 - Install termination cap on end of last pipe section. Vertical Termination will twist lock to last section of pipe.
8. After entire vent system has been installed, double check to make sure all vent pipes and termination caps are unobstructed. For horizontal terminations, be sure there are no possible future obstructions from trees, bushes, or snow.

NOTE: The flow of combustion and ventilation shall not be obstructed.

GAS LINE

NOTE

Plumbing connections should only be performed by a qualified, licensed plumber. Main gas supply must be off when plumbing gas line to fireplace or performing service.

- Step 1. Consult all codes. All gas piping must be installed to comply with local codes, or in the absence of local codes, with the latest edition of the National Fuel Gas Code ANSI Z223.1
- Step 2. This appliance and its individual shutoff valve must be disconnected from the gas supply piping system during any pressure testing of that system at test pressure in excess of 1/2 psi (3.5 kPa).
- Step 3. The appliance must be isolated from the gas supply piping system by closing its individual manual shutoff valve during any pressure testing of the gas supply piping system at test pressure equal to or less than 1/2 psi (3.5 kPa).
- Step 4. To ease installation, a flex line has been installed on the valve. Install 1/2" gas line onto flex line. Use new black iron or steel pipe. Internally tinned copper or copper tubing can be used per National Fuel Gas Code, section 2.6.3, providing gas meets sulfide limits, and where permitted by local codes.

WARNING

Support the flex line when attaching pipe. Use a wrench to hold flex connector stationary and DO NOT TWIST the flex line when tightening the 1/2" gas line.

- Step 5. Outside the fireplace, the gas line must be connected to a gas shut-off valve recessed flush into the wall or floor. The valve should be controlled by a removable valve key for safety.
- Step 6. An ANSI approved manual shut-off valve, union and 1/8" NPT pressure tapping point must be installed immediately upstream of the gas supply connection to the appliance, where permitted by local codes.
- Step 7. A sediment trap may be upstream of the appliance to prevent moisture and contaminants from passing through to the fireplace control and burner. Failure to do so could prevent appliance from operating reliably. Consult applicable codes.
- Step 8. An external regulator must be used on all propane / L.P.G. appliances to reduce the supply tank pressure to 13" w.c. (maximum).

WARNING

Connecting directly to an unregulated propane/L.P.G. tank can cause an explosion.

- Step 9. Check gas type. The gas supply must be the same as stated on the appliance's rating decal. If the supply is different, DO NOT INSTALL THE APPLIANCE. Contact your dealer for the correct model.
- Step 10. After completing gas line connection, purge air from gas line and test all gas joints from the gas meter to the appliance for leaks. Use a soap and water solution or a gas sniffer. DO NOT USE AN OPEN FLAME!

STEP-BY-STEP INSTALLATION

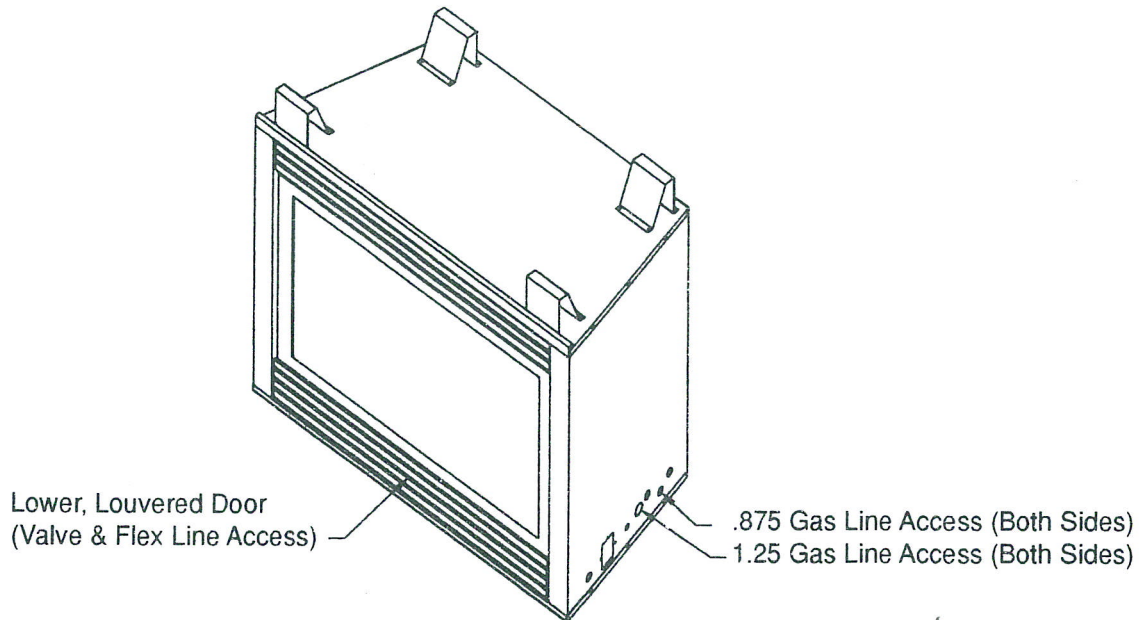

Figure 20: Gas Line Access

GAS PRESSURE CHECK

Milli-Volt Control

Turn captured screw counter clockwise 2 or 3 turns and then place tubing to pressure gauge over test point. After taking pressure reading, be sure and turn captured screw clockwise firmly to re-seal. Do not over torque. Check for gas leaks.

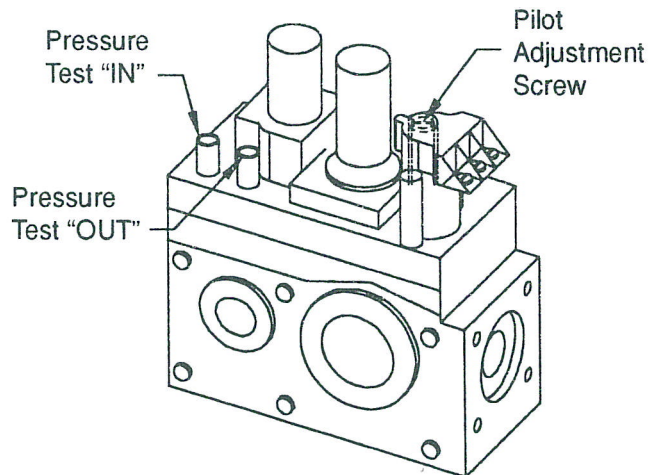

Figure 21: Millivolt Control

ELECTRICAL WIRING

CAUTION

Electrical connections should only be performed by a qualified, licensed electrician. Main power must be off when connecting to main electrical power supply or performing service. All wiring shall be in compliance with all local, city, and state codes. The appliance, when installed, must be electrically grounded in accordance with local codes, or in the absence of local codes, with the National Electrical Code ANSI / NFPA 70 (latest edition) or the Canadian Electrical Code CSA C22.1.

REMOTE WALL SWITCH

A remote wall switch and twelve feet of millivolt wire are provided as standard with this appliance. The millivolt wire has been pre-wired at the valve and routed through the right side, outer shell. (Access is also available on the left side through the square hole on that side). Position the wall switch inside of a junction box (not provided) at the desired location on the wall. Refer to Figure 22 for the wiring diagram. Do not extend beyond the wall switch wire length provided. NOTE: Extended lengths of wire will reduce millivolt output readings and may cause unit shutdowns.

MILLIVOLT CONTROL

The millivolt (thermopile) control is a self powered combustion gas control. It DOES NOT require 110 VAC to operate. **DO NOT CONNECT 110 VAC TO THE GAS CONTROL VALVE OR THE APPLIANCE WILL MALFUNCTION AND THE VALVE BE DESTROYED.** See Figure 22 for wiring diagram. The millivolt system and individual components may be checked with a millivolt meter having 1-1000 mV range. Conduct each check listed below by connecting the meter test leads to the terminals indicated.

A. Thermopile Output Check

Pilot must be lit and the valve control knob turned to the "PILOT" or "ON" position. RS-ON-OFF switch must be in the "OFF" position. Meter leads must be connected to the TP and the TH/TP terminals on the control valve. If the meter reading is not 325 millivolts minimum, then readjust pilot for maximum millivolt output. If millivolt reading is still below minimum specified, replace the thermopile.

B. Thermocouple Output Check

Disconnect thermocouple from valve. Place one lead from meter on the tip of the thermocouple and the other on the thermocouple copper lead. Turn valve control knob to "PILOT" and hold the valve knob in. Start the pilot and read the millivolt output. If the meter reading is not 15 millivolts minimum, then readjust pilot for maximum millivolt output. If millivolt reading is still below minimum specified, replace the thermocouple.

C. Complete Millivolt System Check

Pilot must be lit and the valve control knob turned to the "ON" position. Meter leads must be connected to the TP and the TH/TP terminals of the control valve.

- Turn RS-ON-OFF switch to the "ON" position.
 - A. If meter is reading more than 100 millivolts and the main burners do not come on, then replace control valve.
 - B. If meter is reading less than 100 millivolts, then refer to **TROUBLESHOOTING** section of this manual to determine the cause of the low reading.
- Turn RS-ON-OFF switch to the "RS" position and wall switch to "ON"
 - A. If meter is reading more than 100 millivolts and the main burners do not come on, then replace control valve.
 - B. If meter is reading less than 100 millivolts, then refer to **TROUBLESHOOTING** section of this manual to determine the cause of the low reading.

STEP-BY-STEP INSTALLATION

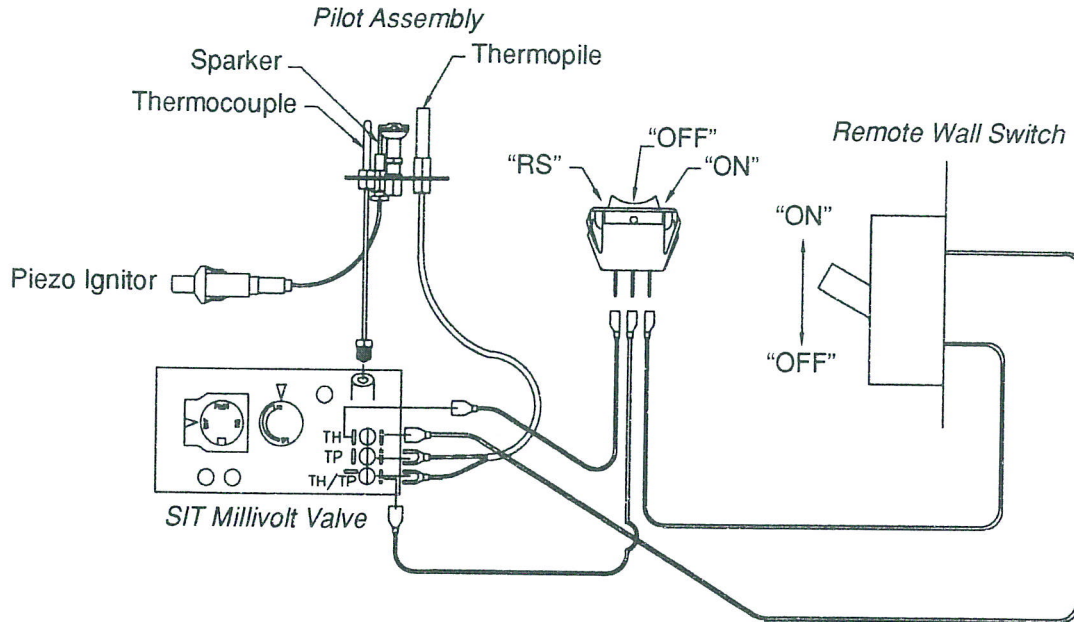

Figure 22: Standard Wiring Diagram

FAN / BLOWER

A fan / blower is optional on all units. The junction box for the blower has been factory installed, and the blower assembly can either be factory or field installed. If unit is added later (field installed) follow directions that come with the blower assembly.

NOTE

Remote blower switch should be pre-wired at installation to avoid costly reconstruction later, if a blower is added at a future date.

If unit is factory installed, the blower has been pre-wired with a rheostat adjustment knob. Figure 23 shows the wiring diagram for the blower.

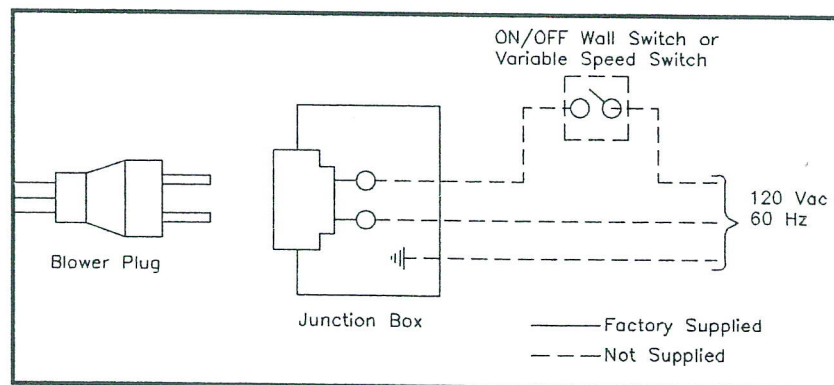

Figure 23: Blower Wiring Diagram

FINISHING

DEFINITIONS

Combustible Materials - Materials made of or surfaced with wood, compressed paper, plant fibers, or other materials that are capable of being ignited and burned. Such materials are considered combustible even though flame-proofed, fire retardant, treated, or plastered.

Non-Combustible Materials - Materials which will not ignite and burn. Such materials are those consisting entirely of steel, iron brick, tile, concrete, slate, glass, marble, or combination thereof, or have a UL Fire rating of Zero (0).

High Temperature Sealant Material - Sealant that will withstand high temperature; General Electric RTV103 or equivalent.

CAUTION

Do not cover any of the louvers (grills) on this appliance. Doing so can create a fire hazard.

FINISHING THE APPLIANCE FLUSH WITH A WALL

When finishing the face of the appliance, combustible material may be brought up to the sides of the appliance, but must never overlap onto the black metal. The black metal may be covered with non-combustible material only. However, the louvers must never be covered with finishing materials.

After applying the finishing material, a non-combustible sealant, 1/8" minimum, must be used to close off any gaps at the top and sides between the fireplace and the finishing to prevent cold air leaks.

Refer to Figure 7 in the **PRE-INSTALLATION** section in this manual for allowable locations for combustible materials.

FINAL INSTALLATION

FINAL INSTALLATION

The final installation consists of: 1) Glass Removal 2) Rock Wool Placement, 3) Log Placement, and 4) Lava Rock Placement. The logs, rock wool, and lava rock are located in a box inside the unit, behind the glass door. Place these items as shown, following the sequence below. These can be added at any time in the future.

1. GLASS REMOVAL

To remove the glass:

- Remove the lower two louvres on the top set of three louvres.
- Open the lower access door.
- There are four latches holding the glass door in place. Two are located on top of the inner combustion chamber, and two are located underneath the inner combustion chamber. These are spring loaded latches. Release latch with flat head screwdriver to avoid pinching your fingers.

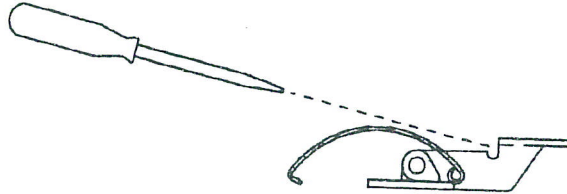

- Remove the glass by lifting up slightly to clear the window bracket on top.
- Put glass aside.

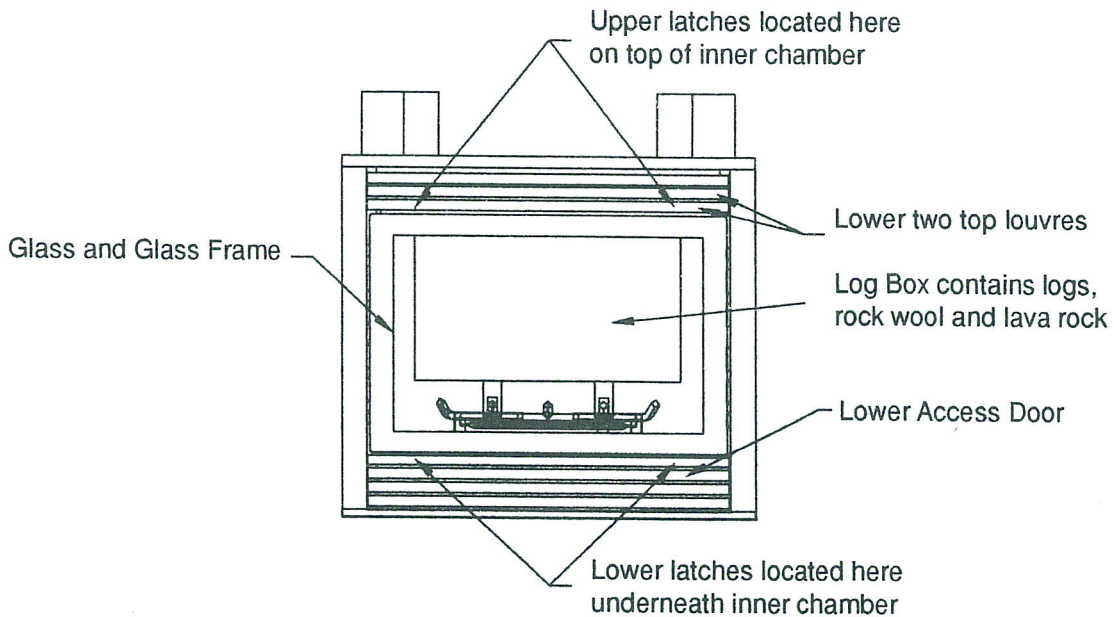

Figure 24: Glass Door Location

2. ROCK WOOL PLACEMENT

Rock wool needs to be placed on the burner covering the holes in order to give the “glowing ember” appearance. Figures 25 & 26 show where to put the rock wool. The rock wool material should be pulled apart into chunks roughly the size of a nickel. Cover the burner areas shown below. The bag of rock wool supplied has an excess of rock wool. The excess can be used to periodically replace the rock wool. **Do NOT use the entire bag of rock wool to cover the burner. This could result in poor performance and potential sooting.**

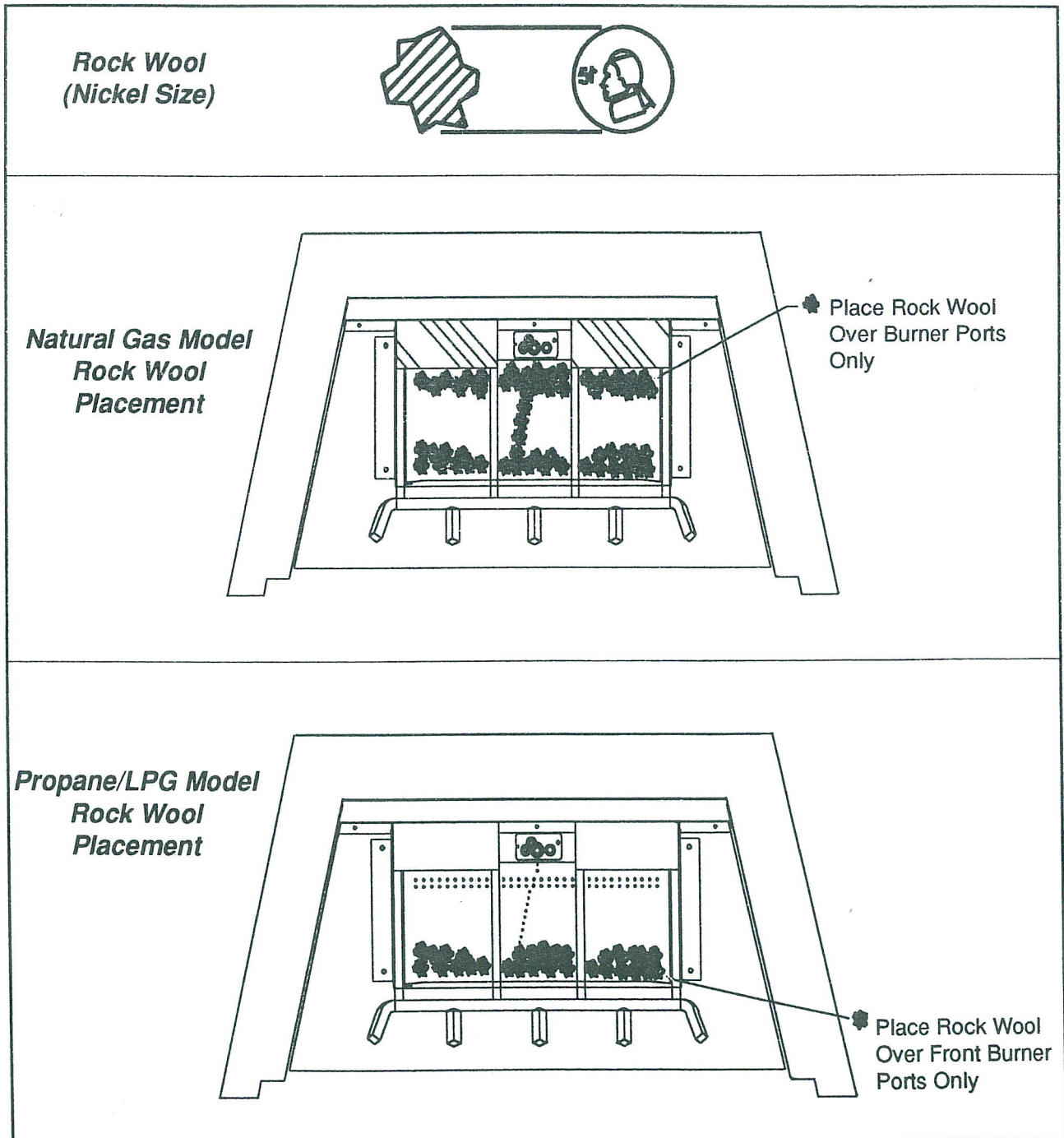
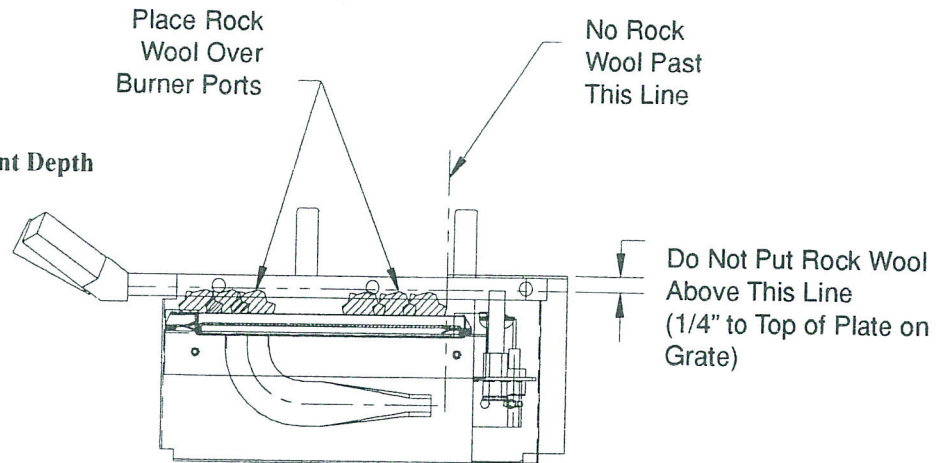

Figure 25: Rock Wool Placement Locations

FINAL INSTALLATION

Figure 26: Rock Wool Placement Depth



3. LOG PLACEMENT

This fireplace is supplied with a set of ceramic logs. Do not handle these logs with your bare hands! Always wear gloves to prevent skin irritation from ceramic fibers. After handling logs, wash your hands gently with soap and water to remove any traces of fibers. After putting rock wool on the burner, install logs as shown in Figure 27.

1. Install rear log #1, aligning the mounting holes in the log with the two pins on the rear two pins on the grate.
2. Install middle logs #2 & #3, aligning each log with the slots on the grate and the two forward pins on the grate (use one pin for each log).
3. Install "L" shaped top log #4, aligning the mounting holes in the log with the two pins on the top of the rear log #1. The front of the log will rest on one of the fingers of the front of the grate.
4. Install other top log #5, aligning back of the log with the cutout in top log #4. The front of log #5 will nest between two fingers of the front of the grate.

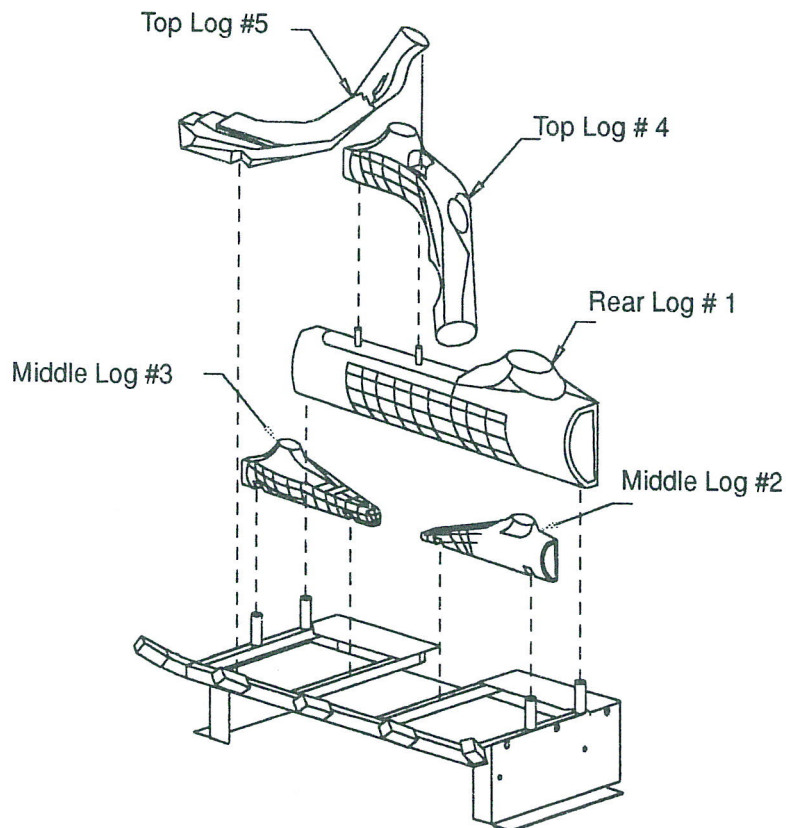

Figure 27: Log Placement

4. LAVA ROCK PLACEMENT, FOR INSTALLATION WITHOUT FIREBRICK FLOOR

Sprinkle lava rock on the floor of the inner chamber. The rock should not be piled up in any area that would permit any air flow under the grate. **DO NOT SPRINKLE THE ROCK ON BURNERS, PILOT, OR LOGS.** To ensure proper air flow, do not block the front of the grate with lava rock or embers chunks. Figure 28 shows the clearance requirements for the front of the unit.

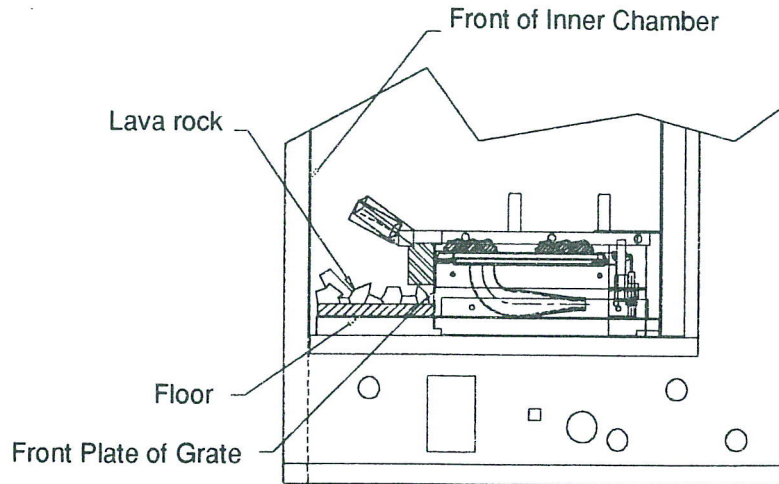

Figure 28: Lava Rock Placement

WARNING

After installing firebrick floors, **DO NOT** install cinder, lava rock, or ember chunk on the floor. This may block the air inlet hole located between the burner and center floor. Blocking the air inlet hole may elevate the temperature of the glass. The elevated temperature, over a period of time, could cause the glass to break.

OPERATING INSTRUCTIONS

OWNER: Please read these instructions and follow these operating instructions at all times. Please note the following.

1. Any safety screen or guard (i.e. glass door) removed for servicing an appliance should be replaced prior to operating the appliance.
2. During manufacturing, fabricating, and shipping, various components of this appliance are treated with certain oils, film, or bonding agents. These chemicals are not harmful but may produce annoying smoke and smells as they are burned off during the initial operation of the appliance; possibly causing headaches or eye and lung irritation. This is a normal and temporary occurrence.
3. For the first few minutes, after each lighting, vapor may condense and fog the glass. This condensation will disappear in a few minutes.

FOR YOUR SAFETY READ BEFORE LIGHTING

WARNING

If you do not follow these instructions exactly, a fire or explosion may result causing property damage, personal injury, or loss of life.

- A. This appliance is equipped with an ignition device (piezo) which automatically lights the pilot. When lighting the pilot, follow these instructions exactly.
- B. **BEFORE LIGHTING** smell all around the appliance area for gas. Be sure to smell next to the floor because some gas is heavier than air and will settle on the floor.

WHAT TO DO IF YOU SMELL GAS

- Do not try to light any appliance
 - Do not touch any electric switch; do not use any phone in your building.
 - Immediately call your gas supplier from a neighbor's phone. Follow the gas supplier's instructions.
 - If you cannot reach your gas supplier, call the fire department.
- C. Use only your hand to push in or turn the gas control knob. Never use tools. If the knob will not push in or turn by hand, don't try to repair it, call a qualified service technician. Force or attempted repair may result in a fire or explosion.
 - D. Do not use this appliance if any part has been underwater. Immediately call a qualified service technician to inspect the appliance and to replace any part of the control system and any gas control which has been under water.

LIGHTING INSTRUCTIONS

1. STOP! Read all the safety instructions found on previous page.
2. Open lower door to reveal RS-OFF-ON switch and gas valve.
3. Turn RS-OFF-ON switch to "OFF". Turn remote switch to "OFF".
4. Push in gas valve knob slightly and turn clockwise to "OFF".
5. Wait five (5) minutes to clear any gas. Then smell for gas, including near the floor. If you smell gas, STOP! Follow "B" in the safety instructions found on previous page. If you don't smell gas, go to the next step.
6. Find pilot - located behind one piece burner, in the center under the rear log.
7. Turn gas valve counterclockwise to "PILOT".
8. With the control knob pushed in, push in and release the piezo ignitor button to light the pilot.
9. Continue pushing the control knob in for a further 60 seconds to prevent the flame detector from shutting off the gas while the probe is warming up. Release the control knob.
10. • If the pilot will not stay lit after several tries, turn the gas control knob clockwise to "OFF" and call your service technician or gas supplier.
• If the knob does not pop out when released, stop and call your service technician or gas supplier.
11. Turn gas valve knob counterclockwise to "ON".
12. After the pilot has been lit for one minute, the burners can be turned on. Turn RS-OFF-ON switch to "ON" or turn RS-OFF-ON switch to "RS" and remote switch to "ON".

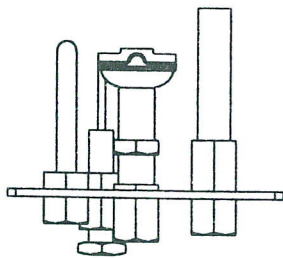

Pilot

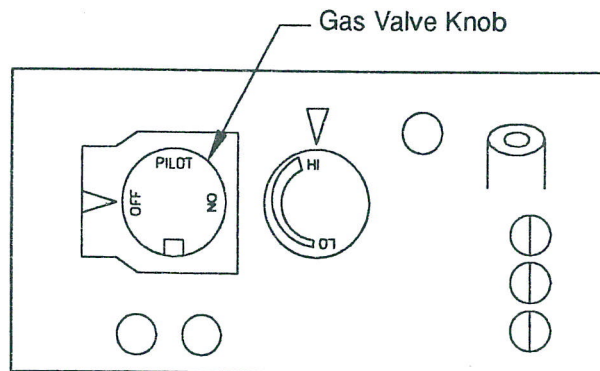

Gas Valve

TO TURN OFF GAS TO APPLIANCE

1. Open lower door to reveal RS-ON-OFF switch and gas valve.
2. Turn RS-OFF-ON switch to "OFF". Turn remote switch to "OFF".

WARNING

To turn off appliance and allow to cool before cleaning. Refer to the section entitled "TO TURN OFF GAS TO APPLIANCE" found in the OPERATING INSTRUCTIONS section of this manual.

MAINTENANCE INSTRUCTIONS

3. Push in gas valve knob slightly and turn clockwise  to "OFF".
4. Close lower door.

IMPORTANT: Turn off gas before servicing appliance. It is recommended that a competent service technician perform these check-ups at the beginning of each heating season.

BURNER & CONTROL COMPARTMENT

Keep the control compartment, logs, and burner areas surrounding the logs clean by vacuuming or brushing at least twice a year. Replace rock wool if necessary. See "Rock Wool Placement" in FINAL INSTALLATION section. Inspect and clean burner air intake holes. Failure to keep air intake holes clean will result in sooting and poor performance.

FLAME PATTERNS

The flames from the pilot and burner should be visually checked as soon as the heater is installed and periodically during normal operation.

The pilot flame must always be present when the appliance is in operation. Refer to Figure 30 for pilot flame appearance. The pilot flame has three distinct flames, one engulfing the thermopile, one engulfing the thermocouple, and the other reaching to the main burner.

In normal operation, at full rate, and after approximately 15-30 minutes, the flame appearance in Figure 31 should be observed. *NOTE: The type of installation, vent system configuration, and wind effects may cause the flame patterns to vary.*

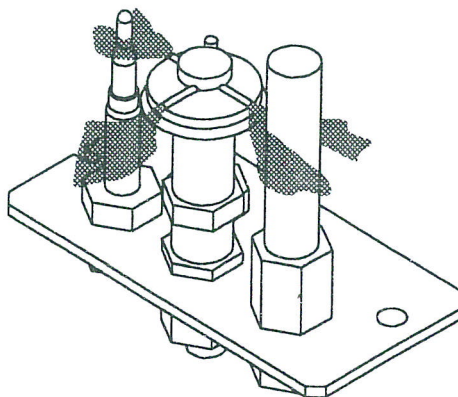

Figure 30: Pilot Flame Appearance

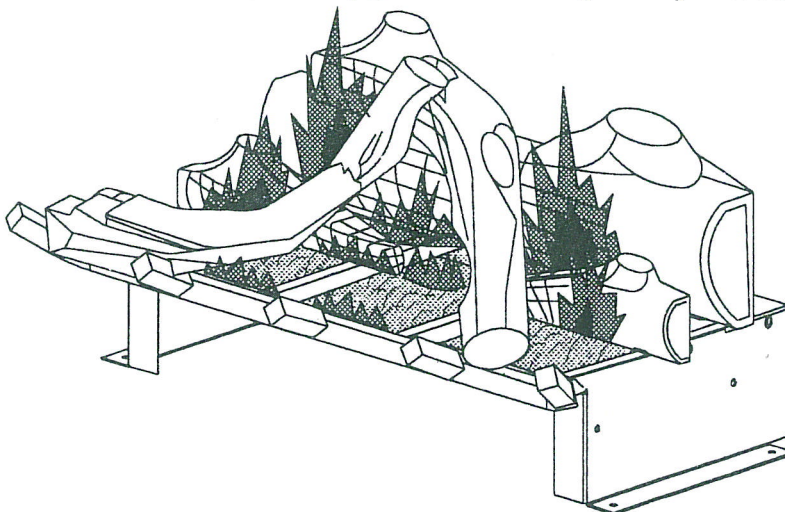

Figure 31: Flame Appearance

VENT SYSTEM

The appliance and venting system should be inspected before initial use and at least annually by a qualified field service person. Inspect the external vent cap on a regular basis to make sure that no debris is interfering with the air flow.

GLASS DOOR

Periodically clean the glass door as necessary. *NOTE: You should thoroughly clean the inside of the glass door after using the fireplace for the two or three times.*

When cleaning the glass, remember:

1. **DO NOT REMOVE THE GLASS WHEN HOT.** Allow glass to cool before removal.
2. **NEVER** use abrasive materials.
3. Keep children and pets a safe distance away.
4. Never operate the appliance without the glass door properly secured.
5. Never operate the appliance if the glass is broken.
6. Replace any glass that is chipped, cracked, or broken. Replacement glass door assemblies **MUST** be supplied by the appliance manufacturer - **NO SUBSTITUTE MATERIALS MAY BE USED.**
7. Handle glass door with care to avoid striking or scratching it on hard objects.

To clean glass door, follow "Glass Removal" procedure outlined in the **FINAL INSTALLATION** section. Clean the glass with a nontoxic, noncorrosive, non-abrasive, mild-cleaning solution. Simply apply an adequate amount to the glass and wipe off with a damp cloth. After all maintenance has been completed, re-install glass door.

LOGS

Leave logs installed in the appliance for cleaning. Vacuum surface of the logs with a brush attachment. If logs must be removed for cleaning. Handle carefully by holding gently at each end. Gloves are recommended to prevent skin irritation from ceramic fibers. If skin becomes irritated, wash gently with soap and water. Vacuum surface of logs with brush attachment or brush logs with a soft bristle brush (i.e. clean, dry paint brush). To place logs back in the appliance, refer to "Log Placement" found in the **FINAL INSTALLATION** section. **DO NOT USE CLEANING FLUID TO CLEAN LOGS.**

PARTS LIST / ILLUSTRATION - Firebox

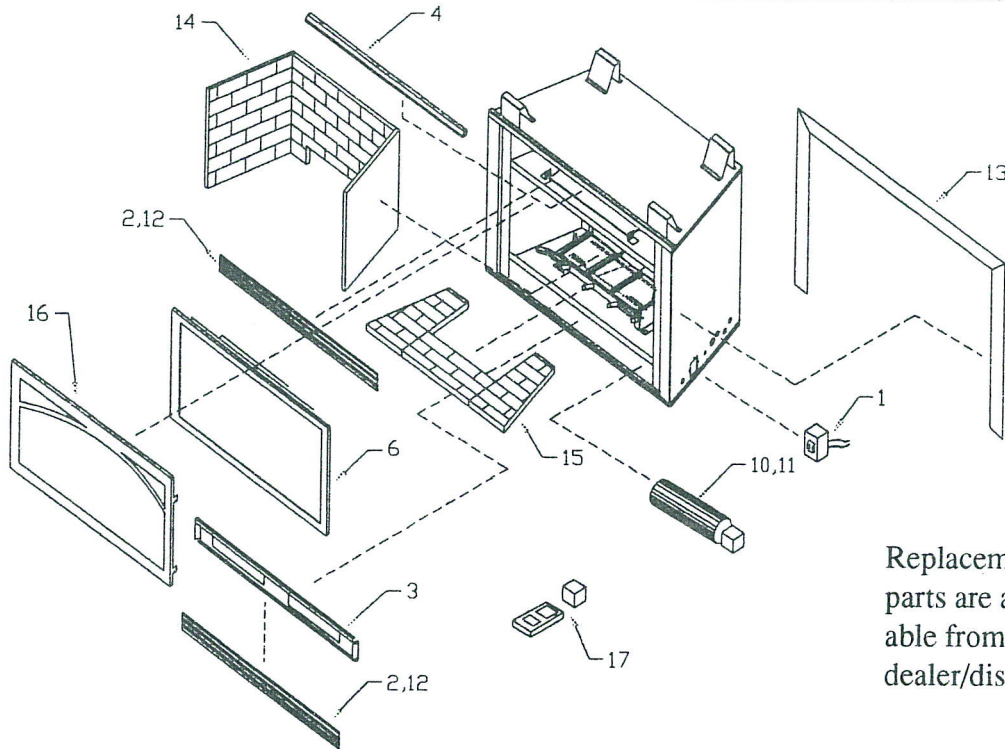

Replacement parts are available from your dealer/distributor.

ITEM	DESCRIPTION	QTY	GDVR36	GDVT36	GDVR42	GDVT42
------	-------------	-----	--------	--------	--------	--------

STANDARD FEATURES

1	Junction Box Assy	1	26D0200	26D0200	26D0200	26D0200
2	Louvres - Black	6	26D0697	26D0697	26D0699	26D0699
3	Door - Access	1	26D0570	26D0570	26D0572	26D0572
4	Hood	1	NA	NA	NA	NA
5	Glass Door Assembly	1	28D0595	28D0595	28D0596	28D0596

FACTORY INSTALLED OPTIONS

7	Standard Firebrick Left or Right	2	28D0800	28D0800	28D0800	28D0800
8	Standard Firebrick - Center	1	28D0802	28D0843	28D0801	28D0842
9	Brass Louvres	6	26D0703	26D0703	26D0705	26D0705
10	Blower	1	26D0748	26D0748	26D0748	26D0748

ACCESSORIES

11	Forced Air Blower Kit	1	BLO	BLO	BLO	BLO
12	Louvres					
	Brass	6	L36BR	L36BR	L42BR	L42BR
	Chrome	6	L36CH	L36CH	L42CH	L42CH
	Filigree	6	BRFK36	BRFK36	BRFK42	BRFK42
13	Trim Surround Sets					
	Curved Design - Brass	1	BRKT36C	BRKT36C	BRKT42C	BRKT42C
	Curved Design - Chrome	1	CHTK36C	CHTK36C	CHTK42C	CHTK42C
	Curved Design - Black	1	BLTK36C	BLTK36C	BLTK42C	BLTK42C
	4"-Wide Brass Wall Trim	1	BRTW36	BRTW36	BRTW42	BRTW42
14	Firebrick Walls					
	Standard	1	FB36T3	FB36T4	FB42T3	FB42T4
	Weathered	1	FB36W3	FB36W4	FB42W3	FB42W4
15	Firebrick Floor					
	Standard	1	FB36TF	FB36TF	FB42TF	FB42TF
	Weathered (Embered Floor)	1	FB36WFA	FB36WFA	FB42WFA	FB42WFA
16	Arch					
	Black	1	BAF36	BAF36	BAF42	BAF42
	Brass	1	BRAF36	BRAF36	BRAF42	BRAF42
17	Remote, Hand Held	1	MVHHR	MVHHR	MVHHR	MVHHR

PARTS LIST / ILLUSTRATION - Burner/Baseplate Assembly

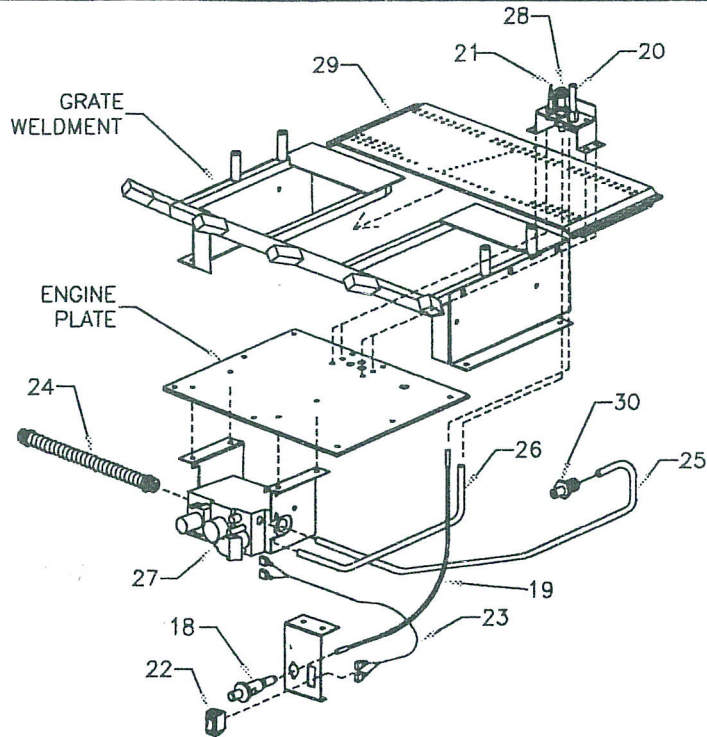

ITEM	DESCRIPTION	QTY	GDVR36	GDVT36	GDVR42	GDVT42
------	-------------	-----	--------	--------	--------	--------

COMMON COMPONENTS

18	Piezo Ignitor	1	14D0503	14D0503	14D0503	14D0503
19	Wire - Peizo *	1	24D0603	24D0603	24D0603	24D0603
20	Thermopile *	1	24D0809	24D0809	24D0809	24D0809
21	Thermocouple*	1	28D0400	28D0400	28D0400	28D0400
22	RS-ON-OFF Switch	1	26D0491	26D0491	26D0491	26D0491
23	Wire - Switch	1	17D0253	17D0253	17D0253	17D0253
24	Flex Line	1	26D0493	26D0493	26D0493	26D0493
25	Burner Tube	1	28D0300	28D0300	28D0300	28D0300

NATURAL GAS COMPONENTS

26	Pilot Tube	1	28D0301	28D0301	28D0301	28D0301
27	Valve - Control *	1	28D0401	28D0401	28D0401	28D0401
28	Pilot Assy *	1	26D0500	26D0500	26D0500	26D0500
29	Burner	1	28D0519	28D0519	28D0516	28D0516
30	Injector	1	28D0420	28D0423	28D0423	27D0426
31	Engine Assy	1	28D0428	28D0428	28D0428	28D0428

PROPANE / LP COMPONENTS

26	Pilot Tube	1	28D0594	28D0594	28D0594	28D0594
27	Valve - Control *	1	28D0402	28D0402	28D0402	28D0402
28	Pilot Assy *	1	26D0501	26D0501	26D0501	26D0501
29	Burner	1	28D0702	28D0702	28D0705	28D0705
30	Injector	1	28D0421	28D0425	28D0425	28D0431
31	Engine Assy	1	28D0429	28D0429	28D0429	28D0429

* Part of Engine Assy

PARTS LIST / ILLUSTRATION - Logs

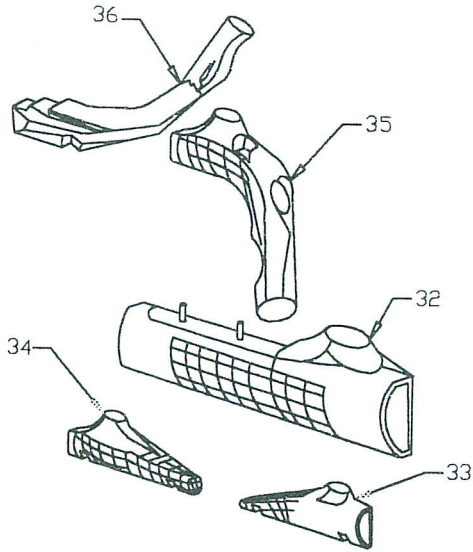

ITEM	DESCRIPTION	QTY	GDVR36	GDVT36	GDVR42	GDVT42
------	-------------	-----	--------	--------	--------	--------

LOGS

32	Rear Log	1	28D0555	28D0555	28D0818	28D0818
33	Middle Log - Right	1	28D0556	28D0556	28D0819	28D0819
34	Middle Log - Left	1	28D0557	28D0557	28D0820	28D0820
35	Top Log - "L with hole"	1	28D0558	28D0558	28D0573	28D0573
36	Top Log - Left	1	28D0559	28D0559	28D0574	28D0574

PARTS LIST / ILLUSTRATION - Pipe and Terminations

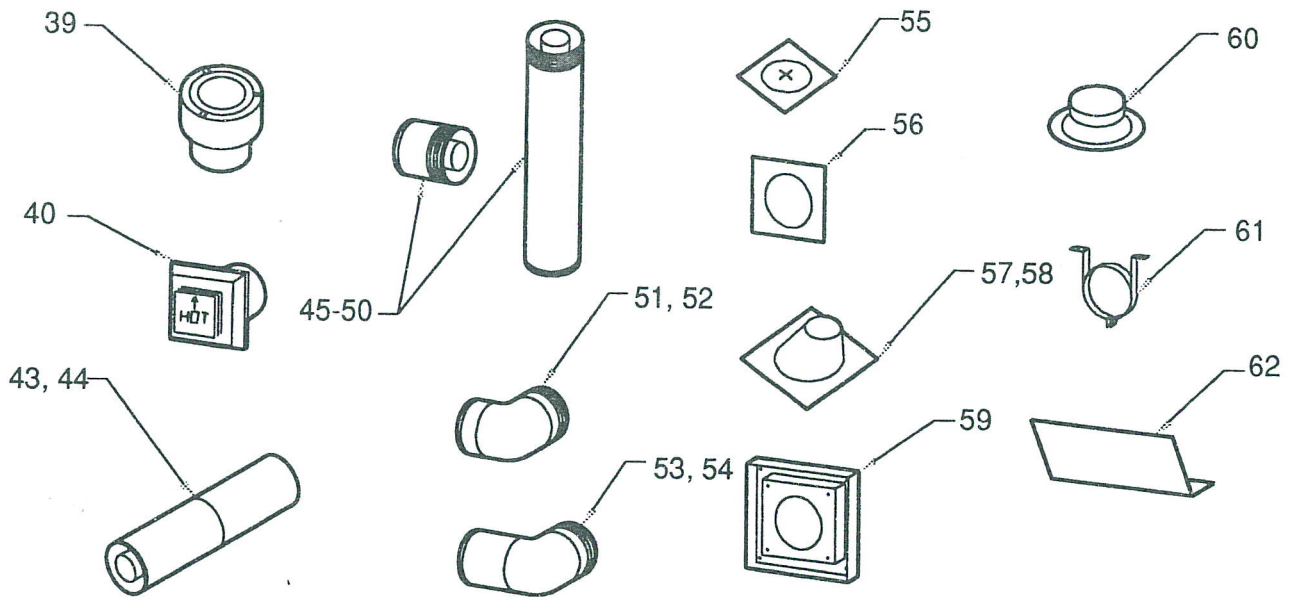

ITEM	DESCRIPTION	SIMPSON/DURAVENT OR MONESSEN PART NUMBER	QTY IN PKG
------	-------------	---	------------

PIPE COMPONENTS

39	Termination Cap - Vertical (low profile)	1280	1
40	Termination Cap - Horizontal (high wind)	1285	1
43	Pipe - 11"-14.63" extension	1211	1
44	Pipe - 17"-24" extension	1217	1
45	Pipe - 6" length	1208	4
46	Pipe - 9" length	1207	4
47	Pipe - 12" length	1206	4
48	Pipe - 24" length	1204	4
49	Pipe - 36" length	1203	4
50	Pipe - 48" length	1202	4
51	Elbow - 45 Degree	1245	4
52	Elbow - 45 Degree, swivel	1245G	4
53	Elbow - 90 Degree	1290	4
54	Elbow - 90 Degree, swivel	1290G	4
55	Ceiling Firestop	1263	4
56	Wall Firestop	1242	4
57	Adjustable Flashing	1243	6
58	Steep Pitch Flashing	1243s	6
59	Standoff - Vinyl Siding	1250	1
60	Collar - Storm	1253	4
61	Strap - Wall	1288	4
62	Deflector Shield	28D0564 (Monessen P/N)	1

TROUBLESHOOTING

WARNING

Turn appliance OFF and allow to cool before servicing. Only a qualified service person should service and repair the heater.

SYMPTOM	POSSIBLE CAUSE	ACTION
Spark Ignitor will not light pilot after repeated triggering of red button.	A. Wire Disconnected.	Open door and check to make sure wire is connector to ignitor.
	B. Defective Ignitor.	Check for spark at electrode and pilot; if no spark and electrode wire is properly connected, replace ignitor. Check remote shut off valves from fireplace.
	C. No gas or low gas pressure.	Low pressure can be caused by bent lines, restricted lines, or low line pressure. Consult with plumber or gas supplier.
	D. No LP in tank	Check LP (propane) tank. Refill tank.
Pilot will not stay lit after carefully following the instructions.	A. Defective thermocouple.	Check that thermocouple flame impinges on thermocouple. Clean and/or adjust pilot for maximum flame impingement. Ensure that the thermocouple connection at the gas valve is fully inserted and tight. Disconnect the thermocouple from the valve, place one millivolt meter lead wire on the tip of the thermocouple and the other meter lead wire on the thermocouple copper lead. Start the pilot and hold the valve knob in. If the millivolt reading is less than 15 mV, replace the thermocouple.
	B. Defective Valve.	If thermocouple is producing more than 15 millivolts, replace faulty valve.
Pilot burning, valve knob turned to "ON", RS-ON-OFF switch is to "RS" or "ON", but burner will not ignite	A. "RS-ON-OFF" switch, wall switch, remote, or wire defective.	Check switches and wires for proper connection. Place jumper wires across terminals of switch. If burner comes on, replace defective switch. If OK, place jumper wires across wires at gas valves (the two terminals marked TH). If burner comes on, wires are faulty or connections are bad. If the pilot flame is not close enough to the thermopile, adjust pilot flame.
	B. Defective or Malfunctioning Thermopile.	Check thermopile wire connections to make sure all are tight and that the thermopile is fully inserted into the pilot assembly. Check the thermopile with a millivolt meter. Connect leads to TP and TH/TP terminals on the control valve. If meter reading is below 325 mV, replace thermopile.
	C. Defective Valve	Turn valve knob to "ON" and switch to "ON". Take a reading at the thermopile leads (TP & TH/TP) on the valve. If the meter reads greater than 100mV and the burner does not light, replace defective valve.

Glass soots	A. Flame impingement on logs.	Adjust the log set per the directions in the manual so the logs do not impinge. Inspect the tube coming out of the bottom of the burner.
	B. Debris around burner tube opening.	Remove all obstructions.
Flame turns blue and lifts off burner.	A. Insufficient oxygen is being supplied.	Check to make sure vent cap is installed properly and free of obstructions. Inspect vent system to make sure there are no leaks. Check to make sure no obstructions have been placed at burner tube. Be sure glass door is tightly placed and the latches are secure, especially the top corners
Glass has white film on it	A. Normal result of first burning.	Clean glass with cleaner.

IMPORTANT - Please fill out the following information and return to:

Monessen Hearth Systems
149 Cleveland Road
Paris, Kentucky 40361

VENTED GAS FIREPLACE WARRANTY REGISTRATION

NAME _____

STREET ADDRESS _____

CITY, ADDRESS, ZIP _____

HOME BUILDER OR DEALER NAME _____

CITY, STATE _____

LIMITED LIFETIME WARRANTY POLICY

Lifetime Warranty

The following components are warranted for life to the original owner, subject to proof of purchase: Firebox, Combustion Chamber, Heat Exchanger, Grate and Stainless Steel Burners.

Five Year Warranty

The following components are warranted for 5 years to the original owner, subject of proof of purchase: Ceramic Fiber Logs, Catalytic Filter and Aluminized Burners.

Basic Warranty

Monessen Hearth Systems (MHS) warrants the components and materials in your gas appliance to be free from manufacturing and material defects for a period of one year from date of installation. After installation, if any of the components manufactured by MHS in the appliance are found to be defective in materials or workmanship, MHS will, at its option, replace or repair the defective components at no charge to the original owner. MHS will also pay for reasonable labor costs incurred in replacing or repairing such components for a period of one year from the date of installation. Any products presented for warranty repair must be accompanied by a dated proof of purchase.

This Limited Lifetime Warranty will be void if the appliance is not installed by a qualified installer in accordance with the installation instructions. The Limited Lifetime Warranty will also be void if the appliance is not operated and maintained according to the operating instructions supplied with the appliance, and does not extend to (1) firebox/burner assembly damage by accident, neglect, misuse, abuse, alteration, negligence of others, including the installation thereof by unqualified installers, (2) the costs of removal, reinstallation or transportation of defective parts on the appliance, or (3) incidental or consequential damage. All service work must be performed by an authorized service representative.

This warranty is expressly in lieu of other warranties, express or implied, including the warranty of merchantability of fitness for purpose and of all other obligations or liabilities. Monessen Hearth Systems, Inc. does not assume for it any other obligations or liability in connection with the sale or use of the appliance. In states that do not allow limitations on how long an implied warranty lasts, or do not allow exclusion of indirect damage, those limitations of exclusions may not apply to you. You may also have additional rights not covered in this Limited Lifetime Warranty.

MHS reserves the right to investigate any and all claims against the Limited Lifetime Warranty and decide upon method of settlement.

For information about this warranty, contact:

**Technical Services
Monessen Hearth Systems
149 Cleveland Drive
Paris, Kentucky 40361**