

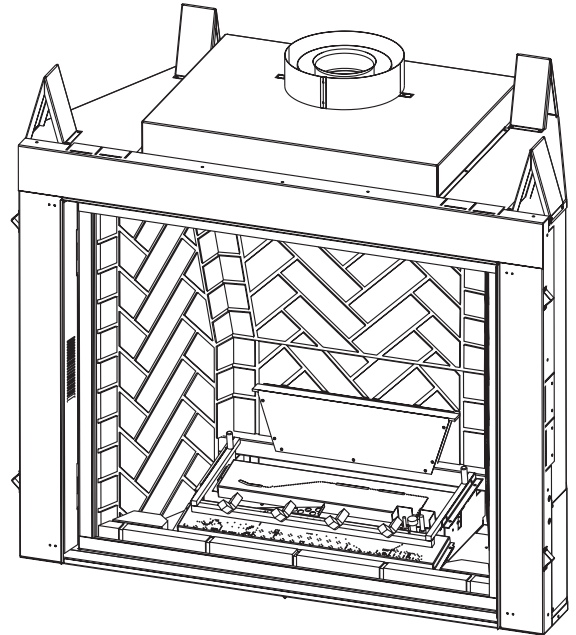

KHLDV Series Direct Vent Gas Fireplace Installation and Operating Instructions

Models: KHLDV400 & KHLDV500



WARNING

IF THE INFORMATION IN THESE INSTRUCTIONS IS NOT FOLLOWED EXACTLY, A FIRE OR EXPLOSION MAY RESULT CAUSING PROPERTY DAMAGE, PERSONAL INJURY OR LOSS OF LIFE.

- Do not store or use gasoline or other flammable vapors and liquids in the vicinity of this or any other appliance.
- **WHAT TO DO IF YOU SMELL GAS**
 - Do not try to light any appliance.
 - Do not touch any electrical switch; do not use any phone in your building.
 - Immediately call your gas supplier from a neighbor's phone. Follow the gas supplier's instructions.
 - If you cannot reach your gas supplier, call the fire department.
- Installation and service must be performed by a qualified installer, service agency or the gas supplier.

WARNING: Improper installation, adjustment, alteration, services or maintenance can cause injury or property damage. Refer to this manual. For assistance or additional information consult a qualified installer, service agency or the gas supplier.

This appliance may be installed in an aftermarket*, permanently located, manufactured home (USA only) or mobile home, where not prohibited by local codes. This appliance is only for use with the type of gas indicated on the rating plate. This appliance is not convertible for use with other gases, unless a certified kit is used.

* Aftermarket: Completion of sale, not for purpose of resale, from the manufacturer.



DUE TO HIGH TEMPERATURES, THE APPLIANCE SHOULD BE LOCATED OUT OF TRAFFIC AND AWAY FROM FURNITURE AND DRAPERIES.

CHILDREN AND ADULTS SHOULD BE ALERTED TO THE HAZARDS OF HIGH SURFACE TEMPERATURE AND SHOULD STAY AWAY TO AVOID BURNS OR CLOTHING IGNITION.

YOUNG CHILDREN SHOULD BE SUPERVISED WHEN THEY ARE IN THE SAME ROOM AS THE APPLIANCE.

CLOTHING OR OTHER FLAMMABLE MATERIAL SHOULD NOT BE PLACED ON OR NEAR THE APPLIANCE.

KEEP THE ROOM AREA CLEAR AND FREE FROM COMBUSTIBLE MATERIALS, GASOLINE, AND OTHER FLAMMABLE VAPORS AND LIQUIDS.

INSTALLER: Leave this manual with the appliance.

CONSUMER: Retain this manual for future reference.

**Thank you and congratulations on your purchase of a
Monessen Fireplace.**

PLEASE READ THE INSTALLATION AND OPERATION INSTRUCTIONS BEFORE USING THE APPLIANCE!

IMPORTANT: Read all instructions and warnings carefully before starting installation.

Failure to follow these instructions may result in a possible fire hazard and will void the warranty.

Important Safety Information	3	Check Gas Pressure - Signature Command	30
Code Approval	4	Electrical Installation - Signature Command	30
Product Features	5	Optional Wall Command Center - Signature Command	31
High Elevations	5	Optional Fan/Blower Systems - Signature Command	32
Gas Pressures	5	Operating Instructions - Signature Command	35
Gas Specifications & Orifice Size	5	Operating Instructions	36
Fireplace & Framing Dimensions.....	6	To Turn Off Gas	36
Pre-Installation Information.....	7	Signature Command System	
Before You Start	7	Operation Instructions	37
Fireplace Framing	7	Remote Control Operation	40
Fireplace Location.....	8	Glass Removal.....	43
Clearances	9	Final Installation	44
Secure Fireplace.....	10	Hearth Brick Placement	44
Finishing Material	10	Rockwool Placement	44
Venting Installation.....	11	Log Placement	45
Installation Precautions	11	Cleaning and Maintenance	48
Installation Clearances.....	11	Burner, Pilot and Control Compartment	48
Installation Planning	12	Pilot Flame	48
Vertical Termination.....	12	Burner Flame	48
Horizontal Termination	12	Venting System	49
How to Use a Vent Graph	14	Glass Door	49
Vertical/Horizontal Termination Configurations	15	Logs	49
Below Grade Installation	17	Rock Wool	49
Vertical Through-the-Roof Applications.....	18	Troubleshooting	50
Installation for Vertical Termination	19	Illustrated Parts Lists	53
Fireplace Installation.....	21	Firebox Components.....	53
Check Gas Type.....	21	Standing Pilot Millivolt Control	54
Install Gas Piping	21	Signature Command System	56
Check Gas Pressure - Millivolt.....	23	Venting Components.....	58
Electrical Installation - Millivolt.....	23	Logs	60
Electrical Wiring	23	Mass Residents Only	62
Remote Wall Switch Installation - Millivolt.....	24	Warranty	63
Optional Fan/Blower Systems - Millivolt	24	Efficiencies.....	64
Operating Instructions - Millivolt	27		
Lighting Pilot for the First Time	27		
Lighting Pilot	28		
Lighting Burner.....	29		
To Turn Off Gas.....	29		

INSTALLER

Please leave these instructions with the appliance.

OWNER

Please retain these instructions for future reference.

WARNING

- **Read this owner’s manual carefully and completely before trying to assemble, operate, or service this fireplace.**
- **Any change to this fireplace or its controls can be dangerous.**
- **Improper installation or use of this fireplace can cause serious injury or death from fire, burns, explosions, electrical shock and carbon monoxide poisoning.**

This fireplace is a vented product. This fireplace must be properly installed by a qualified service person. The glass door must be properly seated and sealed. If this unit is not properly installed by a qualified service person with glass door properly seated and sealed, combustion leakage can occur.

CARBON MONOXIDE POISONING: Early signs of carbon monoxide poisoning are similar to the flu with headaches, dizziness and/or nausea. If you have these signs, the fireplace may not have been installed properly. Get fresh air at once! Have the fireplace inspected and serviced by a qualified service person. Some people are more affected by carbon monoxide than others. These include pregnant women, people with heart or lung disease or anemia, those under the influence of alcohol, and those at high altitudes.

Propane/LP gas and natural gas are both odorless. An odor-making agent is added to each of these gases. The odor helps you detect a gas leak. However, the odor added to these gases can fade. Gas may be present even though no odor exists.

Make certain you read and understand all warnings. Keep this manual for reference. It is your guide to safe and proper operation of this fireplace.

1. This appliance is only for use with the type of gas indicated on the rating plate. This appliance is not convertible for use with other gases unless a certified kit is used.
2. For propane/LP fireplace, do not place propane/LP supply tank(s) inside any structure. Locate propane/LP supply tank(s) outdoors. To prevent performance problems, do not use propane/LP fuel tank of less than 100 lbs. capacity.
3. If you smell gas
 - shut off gas supply.
 - do not try to light any appliance.
 - do not touch any electrical switch; do not use any phone in your building .
 - immediately call your gas supplier from a neighbor’s phone. Follow the gas supplier’s instructions.

4. Never install the fireplace
 - in a recreational vehicle
 - where curtains, furniture, clothing, or other flammable objects are less than 42" from the front, top, or sides of the fireplace
 - in high traffic areas
 - in windy or drafty areas
5. This fireplace reaches high temperatures. Keep children and adults away from hot surfaces to avoid burns or clothing ignition. Fireplace will remain hot for a time after shutdown. Allow surfaces to cool before touching.
6. Carefully supervise young children when they are in the room with fireplace.
7. Do not modify fireplace under any circumstances. Any parts removed for servicing must be replaced prior to operating fireplace.
8. Turn fireplace off and let cool before servicing, installing, or repairing. Only a qualified service person should install, service, or repair the fireplace. Have burner system inspected annually by a qualified service person.
9. You must keep control compartments, burners, and circulating air passages clean. More frequent cleaning may be needed due to excessive lint and dust. Turn off the gas valve and pilot light before cleaning fireplace.
10. Have venting system inspected annually by a qualified service person. If needed, have venting system cleaned or repaired. Refer to *Cleaning and Maintenance, Page 48*.
11. Keep the area around your fireplace clear of combustible materials, gasoline, and other flammable vapor and liquids. Do not run fireplace where these are used or stored. Do not place items such as clothing or decorations on or around fireplace.
12. Do not use this fireplace to cook food or burn paper or other objects.
13. Never place anything on top of fireplace.
14. Do not use any solid fuels (wood, coal, paper, cardboard, etc.) in this fireplace. Use only the gas type indicated on rating plate.

Continued on page 4

Continued from page 3

15. This appliance, when installed, must be electrically grounded in accordance with local codes or in the absence of local codes, with the *National Electrical Code, ANSI/NFPA 70*, or the *Canadian Electrical Code, CSA C22.1*.
16. Do not obstruct the flow of combustion and ventilation air in any way. Provide adequate clearances around air openings into the combustion chamber along with adequate accessibility clearance for servicing and proper operation.
17. When the appliance is installed directly on carpeting, tile or other combustible material other than wood flooring, you must set appliance on a metal or wood panel or hearth pad extending the full width and depth of the appliance.
18. Do not use fireplace if any part has been exposed to or has been under water. Immediately call a qualified service technician to inspect the appliance and replace any part of the control system and any gas control which as been submerged in water.
19. Do not operate fireplace if any log is broken.
20. Do not use a blower insert, heat exchanger insert, or any other accessory not approved for use with this fireplace.
21. Do not operate the fireplace with glass door removed, cracked, or broken.

**IMPORTANT:
PLEASE READ THE FOLLOWING
CAREFULLY**

It is normal for fireplaces fabricated of steel to give off some expansion and/or contraction noises during the start up or cool down cycle. Similar noises are found with your furnace heat exchanger or car engine.

**IMPORTANT:
PLEASE READ THE FOLLOWING
CAREFULLY**

It is not unusual for gas fireplaces to give off some odor the first time it is burned. This is due to the manufacturing process.

Please ensure that your room is well ventilated during burn off — open all windows.

It is recommended that you burn your fireplace for at least ten (10) hours the first time you use it. Place the fan switch in the “OFF” position during this time.

WARNING

Never connect unit to private (non-utility) gas wells. This gas is commonly known as wellhead gas.



CODE APPROVAL

Direct Vent type appliances draw all combustion air from outside of the dwelling through the vent pipe. These appliances have been tested by CSA and found to comply with the established standards for DIRECT VENT GAS FIREPLACE HEATERS in the USA and Canada as follows:

LISTED VENTED GAS FIREPLACE HEATER
TESTED TO: ANSI Z21.88b-2008/CSA 2.33b-2008 STANDARDS

A manufactured home (USA only) or mobile home OEM installation must conform with the **Manufactured Home Construction and Safety Standard, Title 24 CFR, Part 3280**, or when such a standard is not applicable, the **Standard for Manufactured Home Installations, ANSI/NCSBCS A225.1**, or **Standard for Gas Equipped Recreational Vehicles and Mobile Housing, CSA Z240.4**.

- This appliance has been certified for use with either natural or propane gas. See appropriate data plates.
- This appliance is not for use with solid fuels.
- The appliance is approved for bedroom or bedsitting room installations.
- The appliance must be installed in accordance with local codes if any. If none exist use the current installation code. ANSI Z223.1/NFPA 54 in the USA, CSA B149 in Canada.
- This appliance is mobile home approved.
- The appliance must be properly connected to a venting system.
- The appliance is not approved for closet or recessed installations.

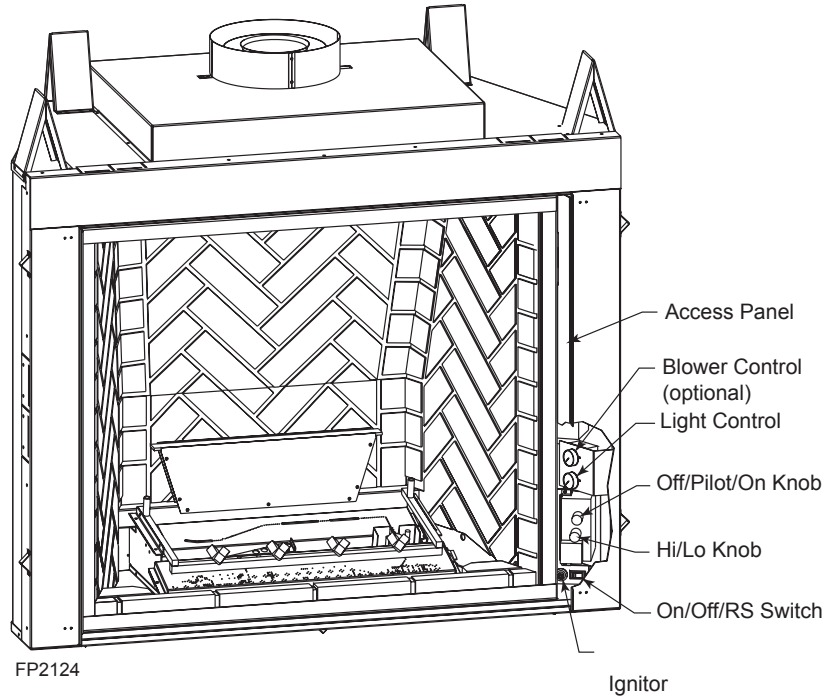

Figure 1 -
KHLDV Series Fireplace
(shown with Millivolt)

HIGH ELEVATIONS

Input ratings are shown in BTU per hour and are certified without deration for elevations up to 4,500 feet (1,370 m) above sea level.

For elevations above 4,500 feet (1,370 m) in USA, installations must be in accordance with the current ANSI Z223.1/NFPA 54 and/or local codes having jurisdiction.

In Canada, please consult provincial and/or local authorities having jurisdiction for installations at elevations above 4,500 feet (1,370 m).

GAS PRESSURES

	Natural	Propane (LP)
Inlet Minimum	4.5" w.c.	11.0" w.c.
Inlet Maximum	10.5" w.c.	13.0" w.c.
Manifold Pressure	3.5" w.c.	10.0" w.c.

GAS SPECIFICATIONS & ORIFICE SIZE

Model	Fuel	Max. Input Btu/h	Min. Input Btu/h
KHLDV500NV	Nat.	50,000	35,500
KHLDV500PV	LP	50,000	38,500
KHLDV500NSC	Nat.	50,000	35,500
KHLDV500PSC	LP	50,000	38,500

Model	Fuel	Orifice Size	
		Front	Rear
KHLDV500	Nat.	2.3 mm	#30 (.1285)
KHLDV500	LP	#50 (.070")	#55 (.052")

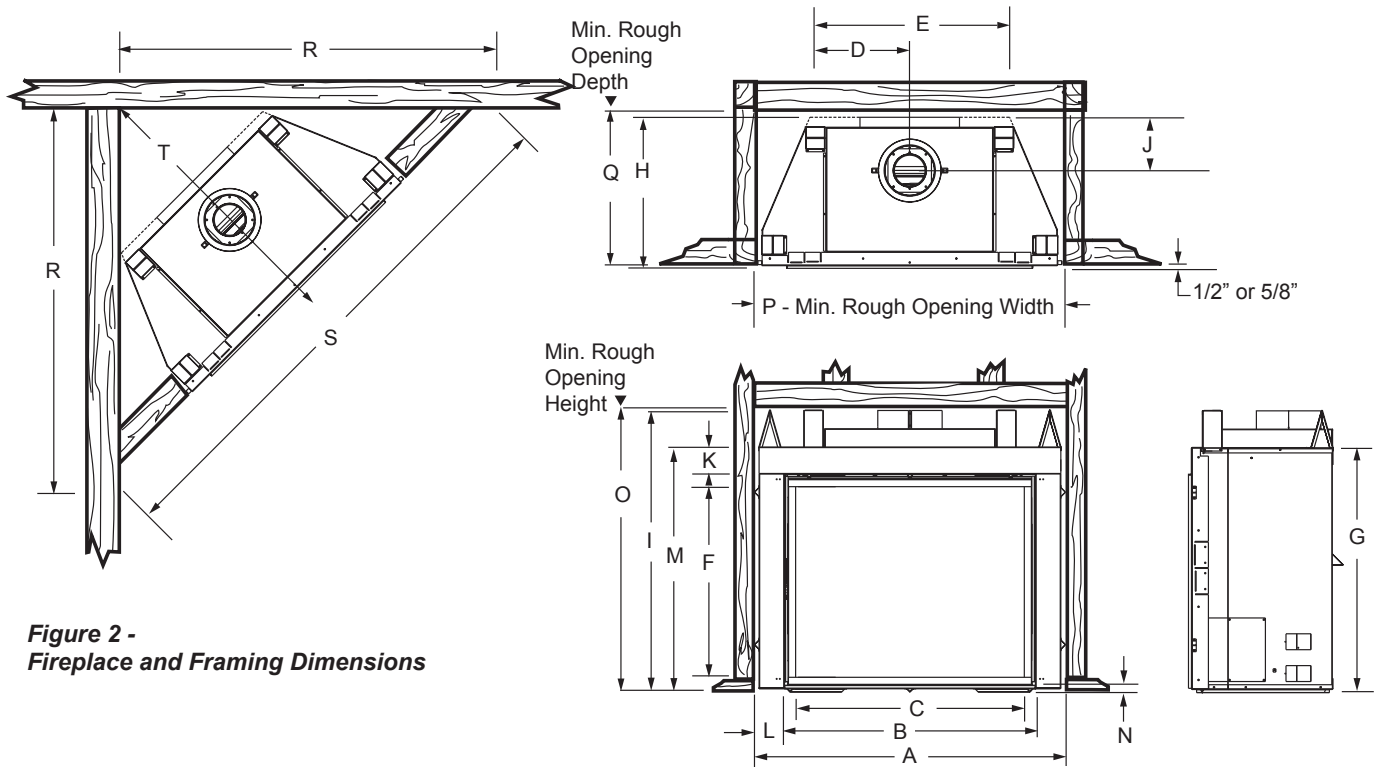

**Figure 2 -
Fireplace and Framing Dimensions**

Ref.	KHLDV400	KHLDV500
A	44 ¹⁵ / ₁₆ " (1141 mm)	48 ¹⁵ / ₁₆ " (1243 mm)
B	35 ¹ / ₂ " (902 mm)	39 ¹ / ₂ " (1003 mm)
C	32" (813 mm)	36" (914 mm)
D	22 ¹ / ₂ " (572 mm)	24 ¹ / ₂ " (622 mm)
E	28 ¹ / ₈ " (714 mm)	32 ¹ / ₈ " (816 mm)
F	30" (762 mm)	30" (762 mm)
G	38 ⁷ / ₁₆ " (976 mm)	38 ⁷ / ₁₆ " (976 mm)
H	23 ⁷ / ₈ " (606 mm)	23 ⁷ / ₈ " (606 mm)
I	44 ³ / ₈ " (1127 mm)	44 ³ / ₈ " (1127 mm)
J	8 ⁹ / ₁₆ " (218 mm)	8 ⁹ / ₁₆ " (218 mm)
K	4 ¹ / ₄ " (108 mm)	4 ¹ / ₄ " (108 mm)
L	4" (102 mm)	4" (102 mm)
M	38 ¹ / ₁₆ " (967 mm)	38 ¹ / ₁₆ " (967 mm)
N	1" (25 mm)	1" (25 mm)
Framing Dimensions		
O	44 ³ / ₄ " (1137 mm)	44 ³ / ₄ " (1137 mm)
P	45 ⁵ / ₁₆ " (1153 mm)	49 ⁵ / ₁₆ " (1253 mm)
Q	23 ⁷ / ₈ " (606 mm)	23 ⁷ / ₈ " (606 mm)
R	53 ⁵ / ₈ " (1362 mm)	56 ⁷ / ₁₆ " (1434 mm)
S	75 ⁷ / ₈ " (1927 mm)	49 ⁷ / ₈ " (2029 mm)
T	37 ¹⁵ / ₁₆ " (964 mm)	39 ¹⁵ / ₁₆ " (1014 mm)

BEFORE YOU START

Read this homeowner manual thoroughly and follow all instructions carefully. Inspect all contents for shipping damage and immediately inform your dealer if any damage is found. Do not install any unit with damaged, incomplete, or substitute parts. Check your packing list to verify that all listed parts have been received. You should have the following:

- Fireplace (Firebox and Burner System)
- Log Set
- Rock Wool
- Noncombustible Panel

ITEMS REQUIRED FOR INSTALLATION

- Phillips Screwdriver
- Hammer
- Saw and/or saber saw
- Measuring Tape
- Electric Drill and Bits
- Pipe Wrench
- Noncombustible finishing material or dura-rock*
- Caulking Material (noncombustible)
- Fireplace Surround Material (noncombustible)
- Piping Complying with Local Codes
- Pipe Sealant Approved for use with Propane/LPG (Resistant to sulfur compounds)
- Framing Materials
- Wall Finishing Materials
- Level
- Pliers
- Square
- Tee Joint

* Only used if desired to cover painted face other than using tiles or marble. If tiles or marble are used around the face then the non-combustible material is not needed.

FIREBOX FRAMING

Firebox framing can be built before or after the appliance is set in place. Refer to Figure 2 for firebox dimensions and framing. Construct firebox framing following *Figure 2* for your specific installation requirements. The framing headers may rest on the top of the firebox standoffs. Do not bring headers below top of standoffs. **NOTE:** When planning your framing and installation, keep in mind that your gas line will come in on the right side of the box (as you are facing it) and your electricity will come in on the left side.

The firebox may be installed directly on a combustible floor or raised on a platform of an appropriate height. When the firebox is installed directly on carpeting, tile, or other combustible material, other than wood flooring, the firebox shall be installed on a metal or wood panel extending the full width and depth of the enclosure.

WARNING	Unit framing is to be rectangular front to back. Failure to do so will cause fire and damage to property.
----------------	--

WARNING	Do not fill spaces around firebox with insulation or other materials. This could cause a fire.
----------------	---

NOTE	COLD CLIMATE INSULATION If you live in a cold climate, seal all cracks around your appliance, and wherever cold air could enter the room, with noncombustible material. It is especially important to insulate the outside chase cavity between the studs and under the floor on which the appliance rests, if the floor is above ground level.
-------------	---

FIREPLACE LOCATION

Plan for the installation of your appliance. This includes determining where the unit is to be installed, the vent configuration to be used, framing and finishing details, and whether any optional accessories (i.e. blower, wall switch, or remote control) are desired. Consult your local building code agency to ensure compliance with local codes, including permits and inspections.

The following factors should be taken into consideration:

- Clearance to side-wall, ceiling, woodwork, and windows. Minimum clearances to combustibles **must be maintained**.
- This fireplace may be installed along a wall, across a corner, or use an exterior chase. Refer to *Figure 3* for suggested locations.
- Location should be out of high traffic areas and away from furniture and draperies due to heat from appliance.
- Never obstruct the front opening of the fireplace.
- Do **not** install in the vicinity where gasoline or other flammable liquids may be stored.
- Vent pipe routing. Refer to the *Venting* section found in this manual for allowable venting configurations.
- These units can be installed in a bedroom. See National Fuel Gas Code ANSI Z233.1/NFPA 54 — (current edition), the Uniform Mechanical Code — (current edition), and Local Building Codes for specific installation requirements.
- These units can be installed in a bathroom.

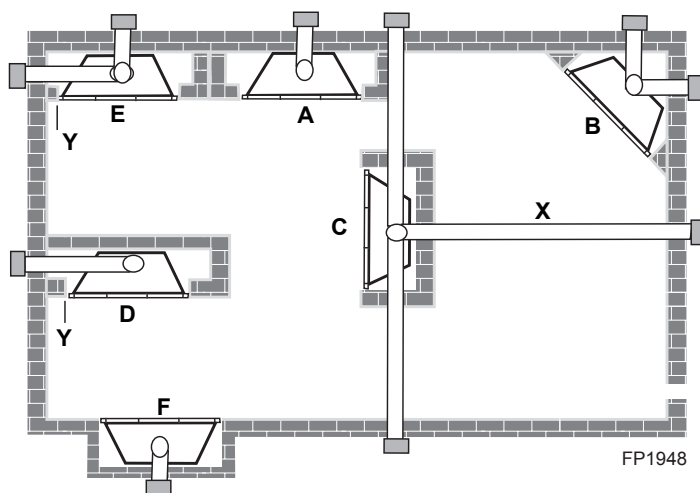

- A Flat on Wall
- B Cross Corner
- C Island**
- D Room Divider*
- E Flat on Wall Corner*
- F Chase Installation
- Y 6" Minimum

** Island (C) and room divider (D) installation is possible as long as the horizontal portion of vent system (X) does not exceed 20'. Refer to *Installing Horizontal Termination Configuration* on Page 15.

* When you install your fireplace in (D) room divider or (E) flat on wall corner positions (Y), a minimum of 6" clearance must be maintained from perpendicular wall and front of fireplace.

**Figure 3 -
Locating Gas Fireplace**

CLEARANCES TO COMBUSTIBLES

WARNING Follow these instructions carefully to ensure safe installation. Failure to follow instructions exactly can create a fire hazard.

The appliance cannot be installed on a carpet, tile or other combustible material other than wood flooring. If installed on carpet or vinyl flooring, the appliance shall be installed on a metal, wood or noncombustible material panel extending full width and depth of the appliance.

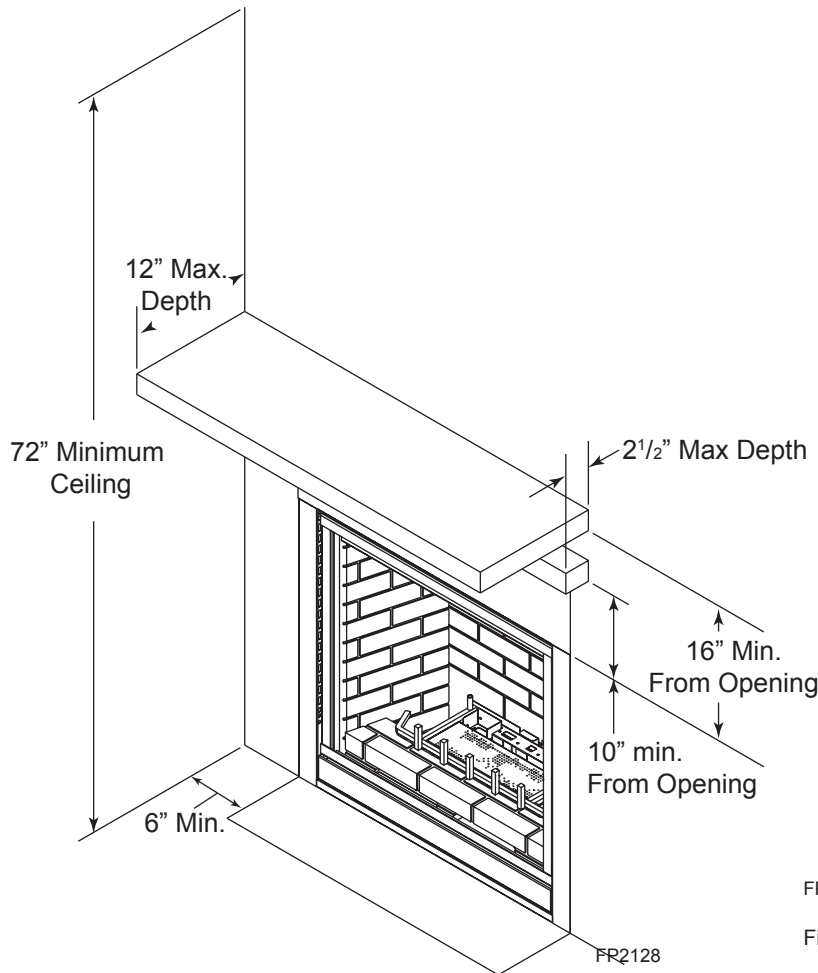
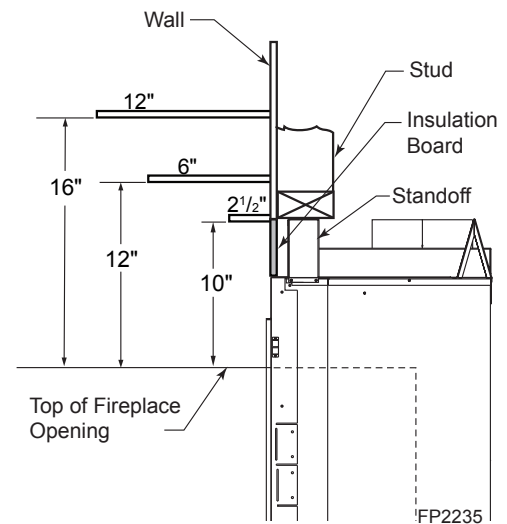
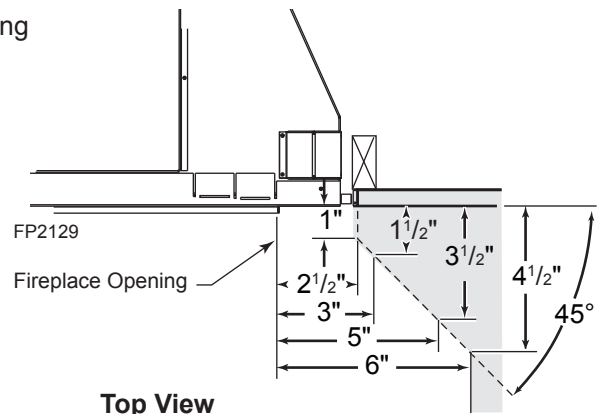

Figure 4 -
Clearances from the mantel, ceiling, and side wall.



Side View



Top View

Figure 5 -
Mantel clearances

MANTEL CLEARANCES

NOTE: The combustible area above the facing must not protrude more than 3/4" from the facing. If it does, it is considered a mantel and must meet the mantel requirements listed in this manual.

The fireplace must be secured to the floor and/or to framing studs as shown in *Figure 6*. Use two (2) wood screws or masonry/ concrete screws to secure fireplace to the floor. Use four (4) screws to attach fireplace to framing. The side nailing flanges are 1/2" or 5/8" to accommodate different wall thickness.

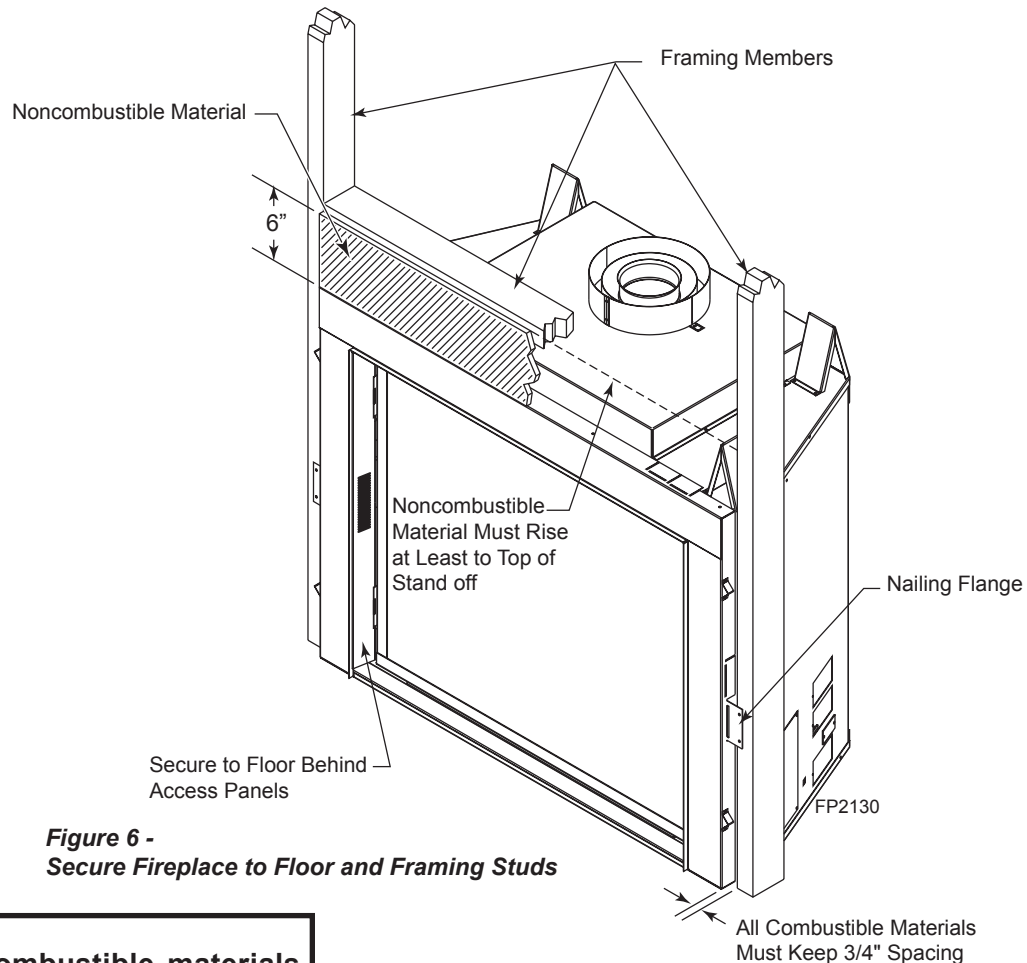

**Figure 6 -
Secure Fireplace to Floor and Framing Studs**

NOTE Never install combustible materials over front face of fireplace.

FINISHING MATERIAL

NOTE: Any remote wiring (i.e. remote control, wall switch, and optional fan) must be done prior to final finishing to avoid costly reconstruction.

Only noncombustible materials (i.e. brick, tile, slate, steel, or other materials with a UL fire rating of Zero) may be used to cover the black painted face of the appliance. It is permissible to bring combustible wall board to the top of the stand-offs on the top and the sides of the unit. A 300°F minimum adhesive may be used to attach facing materials to the black surface. If joints between the finished wall and the fireplace surround are sealed, a 300°F minimum sealant material (General Electric RTV103 or equivalent) must be used.

WARNING

Read all instructions completely and thoroughly before attempting installation. Failure to do so could result in serious injury, property damage or loss of life. Operation of improperly installed and maintained venting system could result in serious injury, property damage or loss of life.

INSTALLATION PRECAUTIONS

Consult local building codes before beginning the installation. The installer must make sure to select the proper vent system for installation. Before installing vent kit, the installer must read this fireplace manual and vent kit instructions.

Only a qualified installer/service person should install venting system. The installer must follow these safety rules:

- Wear gloves and safety glasses for protection.
- Use extreme caution when using ladders or when on rooftops.
- Be aware of electrical wiring locations in walls and ceilings.

The following actions will void the warranty on your venting system:

- Installation of any damaged venting component.
- Unauthorized modification of the venting system.
- Installation of any component part not manufactured or approved by MHS.
- Installation other than permitted by these instructions.

NOTICE

Failure to follow these instructions will void the warranty.

WARNING

Horizontal sections of this vent system require a minimum of 3" clearances to combustibles at the top of the flue and 1" clearance at the sides and bottom *until the flue penetrates the outside wall*. A minimum 1" clearance all around the flue is acceptable at this point of penetration.

Vertical sections of this vent system require a minimum of 2" clearance to combustibles at the top of the unit directly above the stand-off. A minimum of 1" clearance all around the flue is acceptable thereafter.

WARNING

This fireplace must be vented to the outside. The venting system must NEVER be attached to a chimney serving a separate solid fuel burning appliance. Each gas appliance must use a separate vent system. Do not use common vent systems.

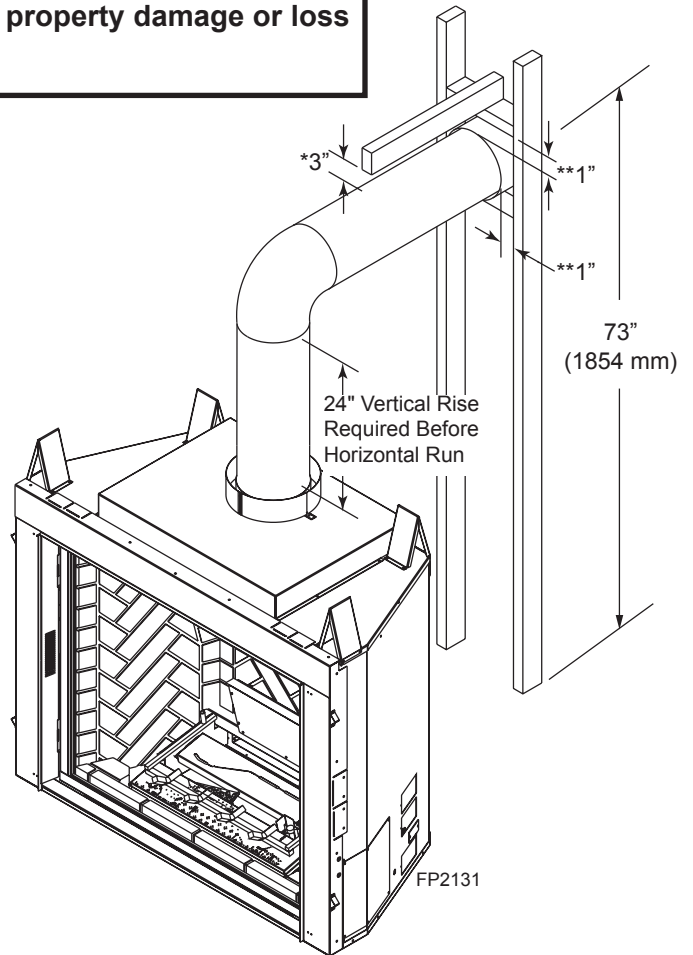

Figure 7 - Combustible Clearances for Vent Pipe

* A minimum of 3" clearance to the top is required along horizontal length until flue pipe penetrates outside wall.

** A minimum 1" clearance to combustibles permitted all around flue at outside wall

INSTALLATION PLANNING

There are two basic types of direct-vent installation:

- Horizontal Termination
- Vertical Termination

It is important to select the proper length of vent pipe for the type of termination you choose. It is also important to note the wall thickness.

WARNING

Never run the vent pipe level or downward. This may cause excessive temperatures which could cause a fire.

FOR HORIZONTAL TERMINATION

Select the amount of vertical rise desired. All horizontal run of venting must have 1/4" rise for every 12" of run towards the termination.

You may use up to three 90° elbows in this vent configuration. Refer to Vertical/Horizontal Termination Configurations on Pages 17 and 18.

FOR VERTICAL TERMINATION

Measure the distance from the fireplace floor to the ceiling. Add the ceiling thickness, the vertical rise in an attic or second story, and allow for sufficient vent height above the roof line.

NOTE: You may use two 45° elbows in place of a 90° elbow. You must follow rise to run ratios when using 45° elbows. The appliance is approved for use with three 90° elbows maximum or a combination of 90° and 45° elbows up to a maximum of 270°.

For two-story applications, firestops are required at each floor level. If an offset is needed in the attic, additional pipe and elbows will be required.

You may use a chase with a vent termination with exposed pipe on the exterior of the house. See *Installing A Vent System in an Outside Chase* below. If pipe is enclosed in chase, it is not exposed.

It is very important that the venting system maintain its balance between the combustion air intake and the flue gas exhaust. Certain limitations apply to vent configurations and must be strictly followed.

INSTALLING A VENT SYSTEM IN AN OUTSIDE CHASE

A chase is a vertical boxlike structure built to enclose venting that runs along the outside of a building. A chase is required for such venting.

NOTICE

Treatment of firestops and construction of the chase may vary from building type to building type. These instructions are not substitutes for the requirements of local building codes. You must follow all local building codes.

NOTICE

When installing in a chase, you should insulate the chase as you would the outside walls of your home. This is especially important in cold climates. Insulation should be considered a combustible material. Maintain proper clearances to all combustible materials.

WARNING

Always maintain minimum clearances around vent systems. The minimum clearances to combustibles for horizontal vent pipe are 3" at the top and 1" at the sides and bottom of the vent system until the pipe penetrates the nearest vertical wall (1" required). A 1" minimum clearance all around the pipe must be maintained at outside wall and on vertical runs. Do not pack the open air spaces with insulation or other materials. This could cause high temperatures and may present a fire hazard.

GENERAL VENTING INFORMATION - TERMINATION LOCATION

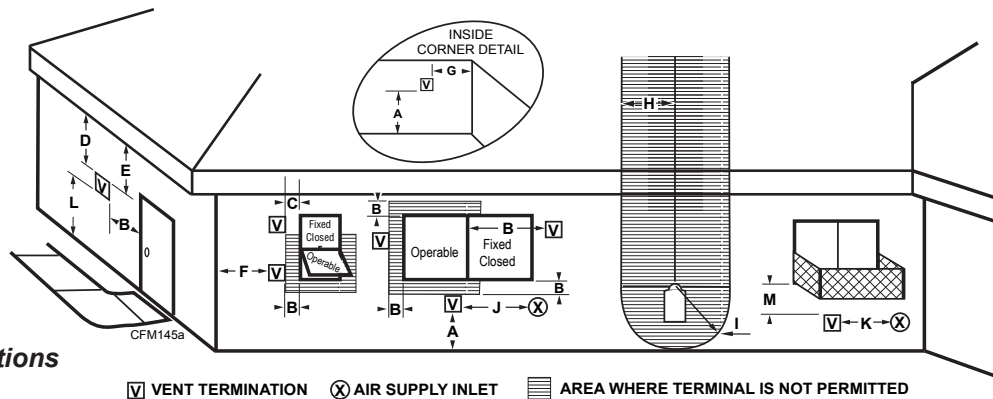

Figure 8 - Termination Locations

	Canadian Installations ¹	US Installations ²
A = Clearance above grade, veranda, porch, deck, or balcony	12" (30 cm)	12" (30 cm)
B = Clearance to window or door that may be opened	6" (15 cm) for appliances < 10,000BTU/h (3kW), 12" (30 cm) for appliances > 10,000 Btuh (3kW) and < 100,000 BTU/h (30kW), 36" (91 cm) for appliances > 100,000 BTU/h (30kW)	6" (15 cm) for appliances < 10,000 BTU/h (3kW), 9" (23 cm) for appliances > 10,000 Btuh (3kW) and < 50,000 BTU/h (15kW), 12" (30 cm) for appliances > 50,000 BTU/h(15kW)
C = Clearance to permanently closed window	12" (305 mm) recommended to prevent window condensation	12" (305 mm) recommended to prevent window condensation
D = Vertical clearance to ventilated soffit located above the terminal within a horizontal distance of 2' (610mm) from the center line of the terminal	18" (458 mm)	18" (458 mm)
E = Clearance to unventilated soffit	12" (305 mm)	12" (305 mm)
F = Clearance to outside corner	see next page	see next page
G = Clearance to inside corner (see next page)	see next page	see next page
H = Clearance to each inside of center line extended above meter/regulator assembly	3' (91 cm) within a height of 15' (5 m) above the meter/regulator assembly	3' (91 cm) within a height of 15' (5 m) above the meter/regulator assy
I = Clearance to service regulator vent outlet	3' (91 cm)	3' (91 cm)
J = Clearance to nonmechanical air supply inlet to building or the combustion air inlet to any other appliances	6" (15 cm) for appliances < 10,000 BTU/h (3kW), 12" (30 cm) for appliances > 10,000 BTU/h (3kW) and < 100,000 Btuh (30kW), 36" (91 cm) for appliances > 100,000 BTU/h (30kW)	6" (15 cm) for appliances < 10,000 BTU/h (3kW), 9" (23 cm) for appliances > 10,000 BTU/h (3kW) and < 50,000 BTU/h (15kW), 12" (30 cm) for appliances > 50,000 BTU/h(15kW)
K = Clearance to a mechanical air supply inlet	6' (1.83 m)	3' (91 cm) above if within 10' (3 m) horizontally
L = Clearance above paved sidewalk or paved driveway located on public property	7' (2.13 m)†	7' (2.13 m)†
M = Clearance under veranda, porch, deck or balcony	12" (30 cm)‡	12" (30cm)‡

1 In accordance with the current CSA-B149 Installation Codes
 2 In accordance with the current ANSI Z223.1/NFPA 54 National Fuel Gas Codes
 † A vent shall not terminate directly above a sidewalk or paved driveway which is located between two single family dwellings and serves both dwellings
 ‡ only permitted if veranda, porch, deck or balcony is fully open on a minimum 2 sides beneath the floor:

NOTE: 1. Local codes or regulations may require different clearances.
 2. The special venting system used on Direct Vent Fireplaces are certified as part of the appliance, with clearances tested and approved by the listing agency.
 3. MHSC assumes no responsibility for the improper performance of the appliance when the venting system does not meet these requirements.

TERMINATION CLEARANCES FOR BUILDINGS WITH COMBUSTIBLE AND NONCOMBUSTIBLE EXTERIORS

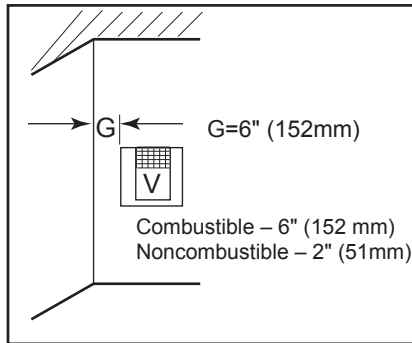

Inside Corner

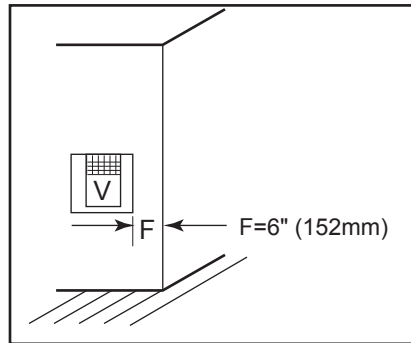

Outside Corner

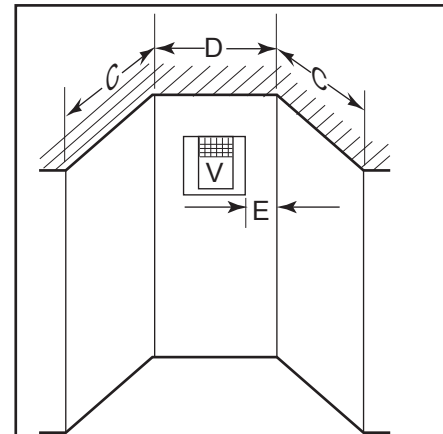

C = Maximum depth of 48" (1219mm) for alcove location
 D = Minimum width for back wall of alcove location
 Combustible - 38" (965mm)
 Noncombustible - 24" (610mm)
 E = Clearance from corner in alcove location
 Combustible - 6" (152mm)
 Noncombustible - 2" (51mm)

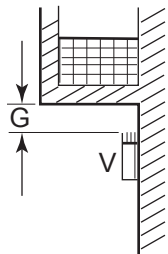

G = Combustible 24" (610mm)
 Noncombustible 18" (457mm)

Balcony with No Side Wall

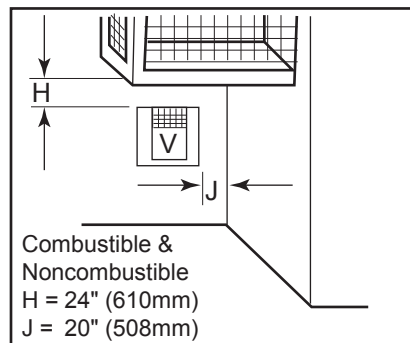

Combustible & Noncombustible
 H = 24" (610mm)
 J = 20" (508mm)

Balcony with Perpendicular Side Wall

**Alcove Location
 Dimensions in Feet**

**Figure 9 -
 Allowable Venting Chart**

HOW TO USE THE VENT GRAPH

The Vent Graph should be read in conjunction with the following vent installation instructions to determine the relationship between the vertical and horizontal dimensions of the vent system.

1. Determine the height of the center of the horizontal vent pipe exiting through the outer wall. Using this dimension on the Sidewall Vent Graph below, locate the point intersecting with the slanted graph line.
2. From the point of this intersection, draw a vertical line to the bottom of the graph.
3. Select the indicated dimension, and position the fireplace in accordance with same.

Example: If the vertical dimension from the floor of the fireplace is 11' (3.4 m) the horizontal run to the face of the outer wall must not exceed 16' (4.9 m).

Sidewall Vent Graph showing the relationship between vertical and horizontal dimensions for a Direct Vent flue system.

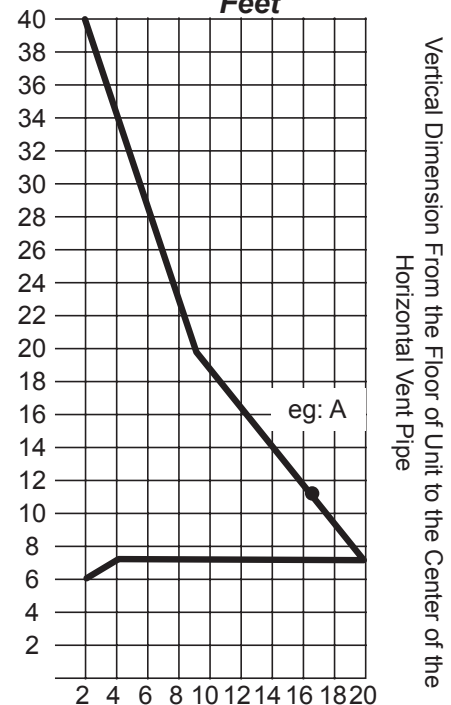

**Figure 10 -
 Rear Wall Venting Graph**

VERTICAL/HORIZONTAL TERMINATION CONFIGURATIONS

Since it is very important that the venting system maintain its balance between the combustion air intake and the flue gas exhaust, certain limitations as to vent configurations apply and must be strictly adhered to.

The Vent Graph, showing the relationship between vertical and horizontal side wall venting, will help to determine the various dimensions allowable. *Figure 10*

NOTE: Horizontal sections of this vent system require a minimum of 3" clearances to combustibles at the top of the flue and 1" clearance at the sides and bottom until the flue penetrates the outside wall. A minimum 1" clearance all around the flue is acceptable at this point of penetration.

Vertical sections of this vent system require a minimum of 1" clearance to combustibles on all sides of the pipe.

When vent exits through foundations less than 20" below outcrop, the termination must be flush up with outcropped wall above.

It is best to locate the fireplace in such a way that minimizes the number of offsets and horizontal vent length.

The horizontal vent run refers to the total length of vent pipe from the flue collar of the fireplace (or the top of the Transition Elbow) to the face of the finished outside wall.

- The maximum number of 90° elbows per side wall installation is three (3). *Figure 11*
- A minimum of 24" is required before a 90° elbow. If a 90° elbow is fitted directly after 24" vertical section mounted to the top of the fireplace, the maximum horizontal vent run before the termination or a vertical rise is 36" (914 mm). *Figure 12*

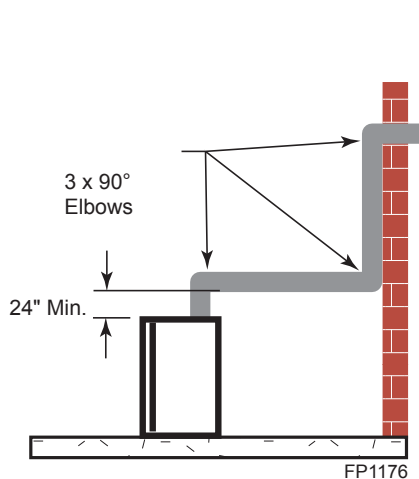

Figure 11 - Maximum Three (3) 90° Elbows Per Installation

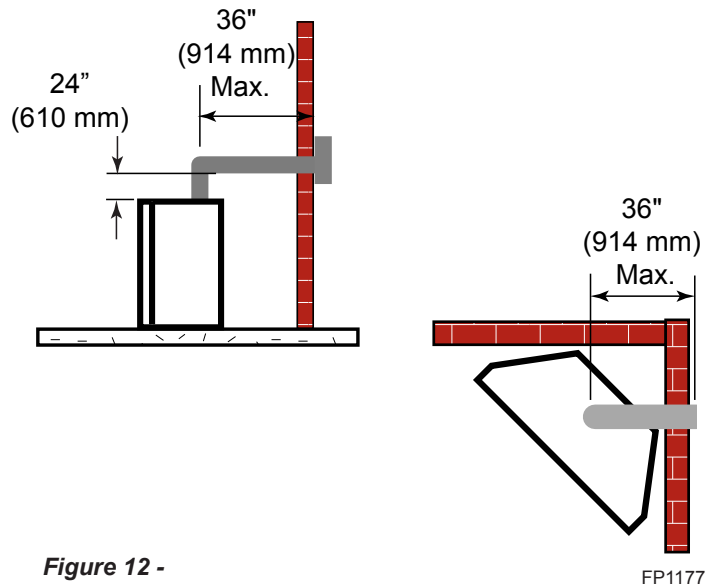

Figure 12 - Maximum Horizontal Run with No Rise

VERTICAL/HORIZONTAL TERMINATION CONFIGURATIONS (continued)

- If a 90° elbow is used in the horizontal vent run (level height maintained) the horizontal vent length is reduced by 36". Refer to Page 17, *Figures 11 and 12*. This does not apply if the 90° elbows are used to increase or redirect a vertical rise. *Figure 14*

Example: According to the vent graph (Page 16) the maximum horizontal vent length in a system with a 10' vertical rise is 20' (6 m) and if a 90° elbow is required in the horizontal vent it must be reduced to 17' (5.2 m).

In *Figures 13 and 14* dimension A plus B must not be greater than 17' (5.2 m).

- The maximum number of 45° elbows permitted per side wall installation is two (2). These elbows can be installed in either the vertical or horizontal run.
- For each 45° elbow installed in the horizontal run, the length of the horizontal run **MUST** be reduced by 18" (45 cm). This does not apply if the 45° elbows are installed on the vertical part of the vent system.
- The maximum number of elbow degrees in a system is 270°. *Figure 15*

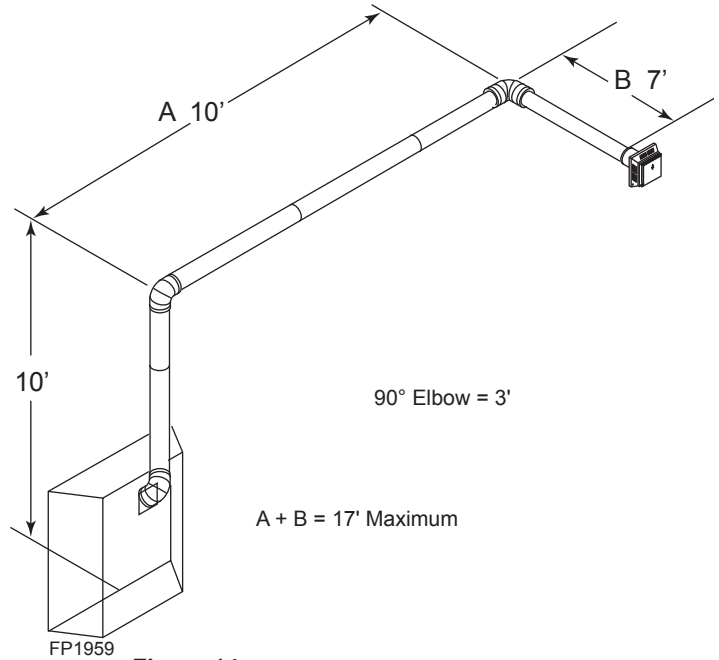

Figure 14 - Maximum Vent Run with Elbows

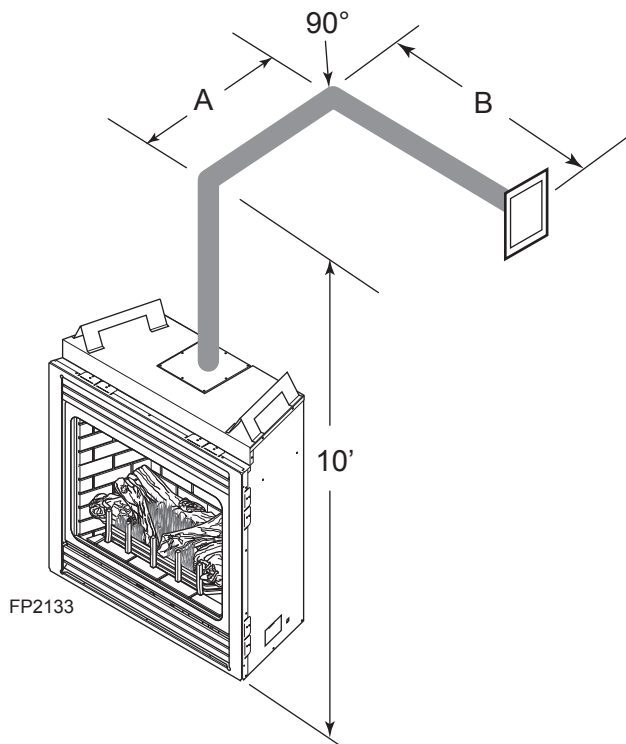
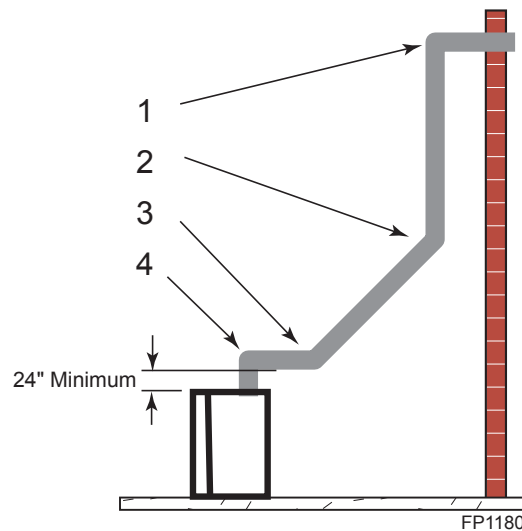

Figure 13 - Horizontal Run Reduction



Example:

Elbow 1 =	90°
Elbow 2 =	45°
Elbow 3 =	45°
Elbow 4 =	90°
Total Angular Variation =	270°

Figure 15 - Maximum Elbow Usage

BELOW GRADE INSTALLATIONS

When it is not possible to meet the required vent terminal clearances of 12" above grade level, a snorkel kit is recommended. It allows installation depth down to 7" (178mm) below grade level. The 7" (178mm) is measured from the center of the horizontal vent pipe as it penetrates through the wall.

Ensure that sidewall venting clearances are observed. If venting system is installed below ground, we recommend a window well with adequate and proper drainage to be installed around the termination area.

If installing a snorkel, a minimum 24" vertical rise is necessary. The maximum horizontal run with the 24" vertical pipe is 36". This measurement is taken from the collar of the fireplace (or transition elbow) to the face of the exterior wall. See the Sidewall Venting Graph for extended horizontal run if the vertical exceeds 24".

1. Establish vent hole through the wall.
2. Remove soil to a depth of approximately 16" below base of snorkel. Install drain pipe. Install window well (not supplied). Refill hole with 12" of coarse gravel leaving a clearance of approximately 4" below snorkel. *Figure 16*
3. Install vent system.
4. Ensure a watertight seal is made around the vent pipe coming through the wall.
5. Apply high temperature sealant caulking (supplied) around the 5" and 8" snorkel collars.
6. Slide the snorkel into the vent pipes and secure to the wall.
7. Level the soil so as to maintain a 4" clearance below snorkel. *Figure 16*

If the foundation is recessed, use recess brackets (not supplied) for securing lower portion of the snorkel. Fasten brackets to wall first, then secure to snorkel with self drilling #8 x 1/2 sheet metal screws. It will be necessary to extend vent pipes out as far as the protruding wall face. *Figure 17*

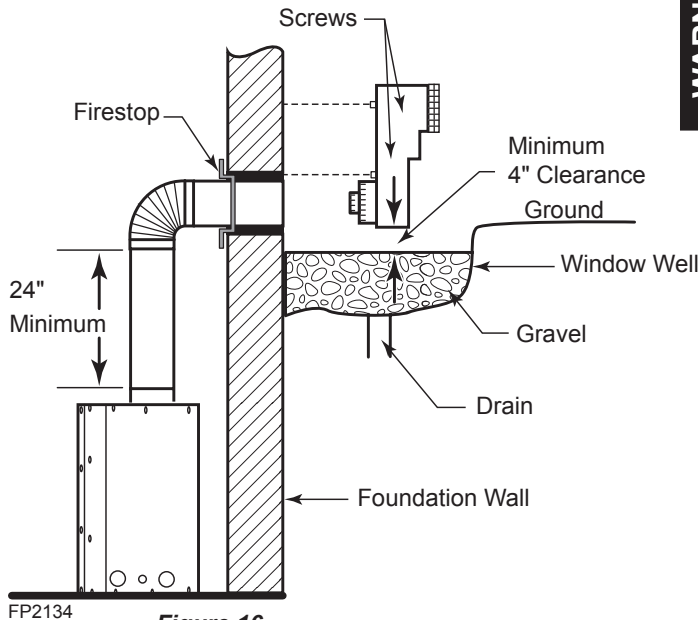

**Figure 16 -
Below Grade Installation**

WARNING

- Do not back fill around snorkel.
- A clearance of at least 4" must be maintained between the snorkel and the soil.

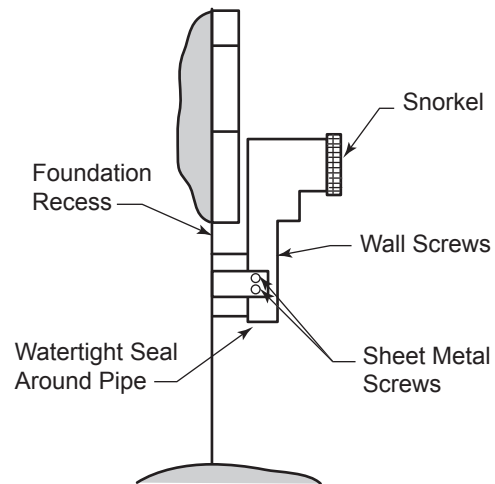

**Figure 17 -
Snorkel Installation, Recessed Foundation**

VERTICAL (THROUGH-THE-ROOF) APPLICATIONS

This gas fireplace has been approved for,

- Vertical installations up to 40' (12 m) in height. Up to a 10' (3 m) horizontal vent run can be installed within the vent system using a maximum of two 90° elbows. *Figure 18*

NOTE: Horizontal sections of this vent system require a minimum of 3" clearances to combustibles at the top of the flue and 1" clearance at the sides and bottom until the flue penetrates the outside wall. A minimum 1" clearance all around the flue is acceptable at this point of penetration.

Vertical sections of this vent system require a minimum of 1" clearance to combustibles on all sides of the pipe.

- Up to two 45° elbows may be used within the horizontal run. For each 45° elbow used on the horizontal plane, the maximum horizontal length must be reduced by 18" (450 mm).

Example: Maximum horizontal length

No elbows	=	10' (3 m)
1x45° elbows	=	8.5' (2.6 m)
2x45° elbows	=	7' (2.1 m)

- A minimum of an 8' (2.5 m) vertical rise is required.
- Two sets of 45°elbows offsets may be used within the vertical sections. From 0 to a maximum of 8' (2.5 m) of vent pipe can be used between elbows. *Figure 19*
- The maximum angular variation allowed in the system is 270°. *Figure 19*
- The minimum height of the vent above the highest point of penetration through the roof is 2' (610 mm).

Example:	Elbow 1	=	90°
	Elbow 2	=	45°
	Elbow 3	=	45°
	Elbow 4	=	90°
<hr/>		Total Angular Variation	= 270°

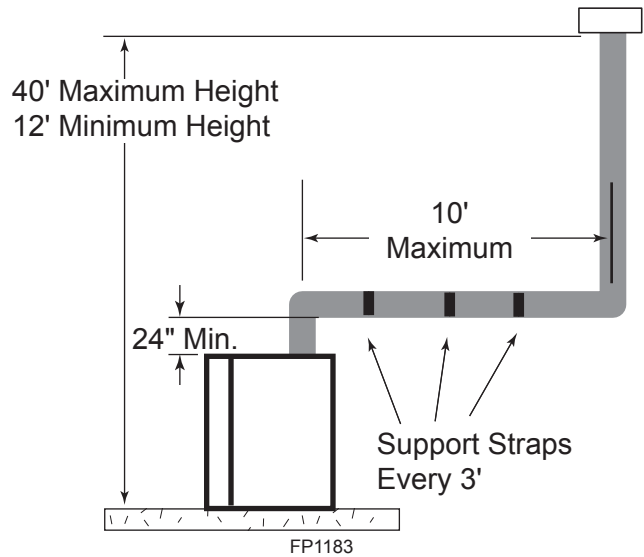

Figure 18 - Support Straps for Horizontal Runs

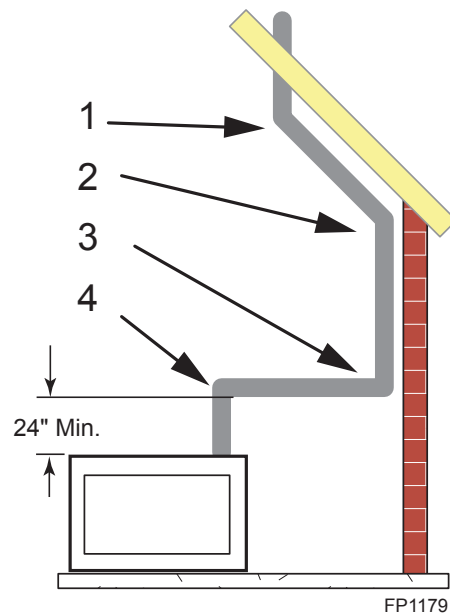

Figure 19 - Maximum Elbow Usage

INSTALLATION FOR VERTICAL TERMINATION

1. Determine the route your vertical venting will take. If ceiling joist, roof rafters or other framing will obstruct the venting system, consider an offset. Refer to Figure 20 to avoid cutting load bearing members.

For optimal flame appearance, a restrictor disk is necessary on straight vertical runs of 10' or more.

- Runs may not incorporate elbows.
- The disk is part number 56D3027 and is included in installation manual packet.
- Drop the disk into a 5" inner collar before installing the first section of flue or install at the last section before installing the termination.
- An additional disk may be installed on runs of 35' or more. Rotate disks perpendicular to each other.

NOTE: Pay special attention to these installation instructions for required clearances (air space) to combustibles when passing through ceilings, walls, roofs, enclosures, attic rafters, etc. Do not pack air spaces with insulation. Also note maximum vertical rise of the venting system and any maximum horizontal offset limitations. Offsets must fall within the parameters shown in Figures 19 and 20.

2. Set fireplace in desired location. Drop a line plumb down from the ceiling to the position of the flue exit. Mark the center point where the vent will penetrate the ceiling. Drill a small locating hole at this point.

Drop a plumb line from the inside of the roof to the ceiling locating hole in the ceiling. Mark the center point where the vent will penetrate the roof. Drill a small locating hole at this point.

FLAT CEILING INSTALLATION

1. Cut a 10 1/2" (241 mm) square hole in the ceiling using the locating hole as a center point. The opening should be framed to 10 1/2"x10 1/2" (241 x 241 mm) inside dimensions as shown in Figure 22 using framing lumber the same size as the ceiling joist. If the area above the ceiling is an insulated ceiling or a room, nail firestop from the top side. This prevents loose insulation from falling into the required clearance space. Figure 21. Otherwise, install firestop below the framed hole. Figure 22

2. Assemble the desired lengths of pipe and elbows necessary to reach from the burner system flue up through the firestop. Be sure pipe and elbow connections are fully twist-locked.

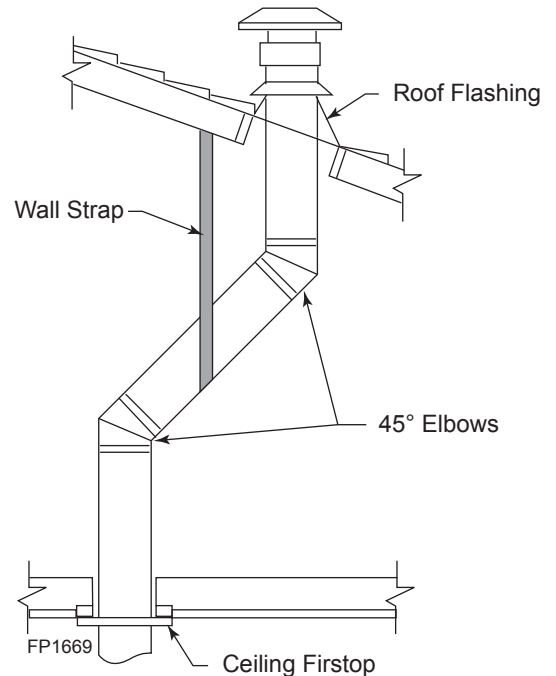

Figure 20 - Offset with Wall Strap and 45° Elbows

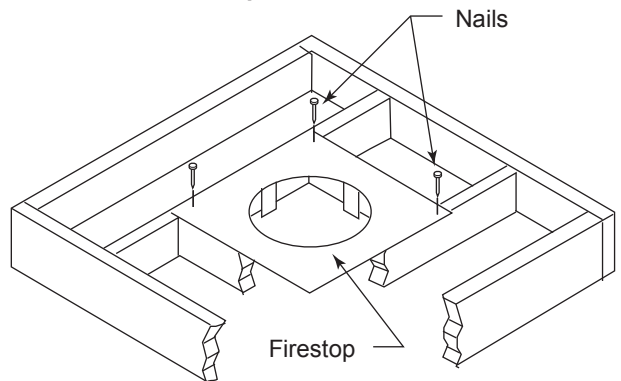

Figure 21 - If Area Above is a Room, Install Firestop above Framed Hole as Shown

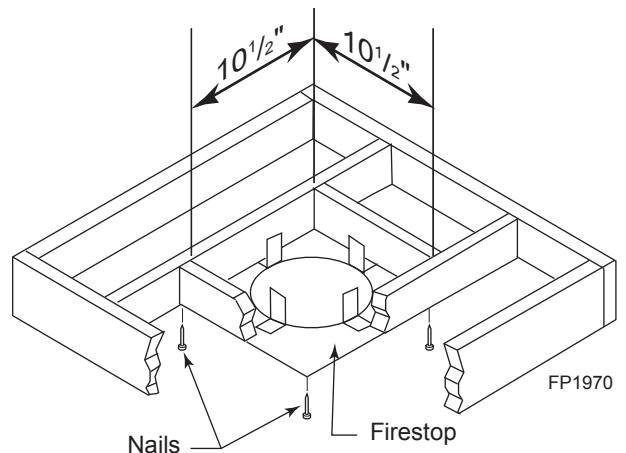

Figure 22 - If Area Above is Not a Room, Install Firestop above Framed Hole as Shown

3. Cut a hole in the roof using the locating hole as a center point. (Cover any exposed open vent pipes before cutting hole in roof). The 10¹/₂"x10¹/₂" (241mm x 241mm) hole must be measured on the horizontal. Actual length may be larger depending on the pitch of the roof. There must be a 1" minimum clearance from the vent pipe to combustible materials. (Insulation should be considered a combustible material).

4. Connect a section of pipe and extend up through the hole.

NOTE: If an offset is needed to avoid obstructions, you must support the vent pipe every three (3) feet. Use wall straps for this purpose. See Figure 18, page 19. Whenever possible, use 45° elbows instead of 90° elbows. The 45° elbow offers less restriction to the flow of the flue gases and intake air.

5. Place the flashing over the pipe section(s) extending through the roof. Secure the base of the flashing to the roof and framing with roofing nails. Be sure roofing material overlaps the top edge of the flashing. There must be a 1" clearance from the vent pipe to combustible materials.

6. Continue to add pipe sections until the height of the vent cap meets the minimum building code requirements.

NOTE: You must increase vent height for steep roof pitches. Nearby trees, adjoining roof lines, steep pitched roofs, and other similar factors may cause poor draft or down-drafting in high winds. Increasing the vent height may solve this problem.

NOTE: If the vent pipe passes through any occupied areas above the first floor, including storage spaces and closets, you must enclose pipe. You may frame and sheetrock the enclosure with standard construction material. Make sure to meet the minimum allowable clearances to combustibles. Do not fill any of the required clearance spaces with insulation.

TERMINATION HEIGHTS FOR VENTS ABOVE FLAT OR SLOPED ROOFS

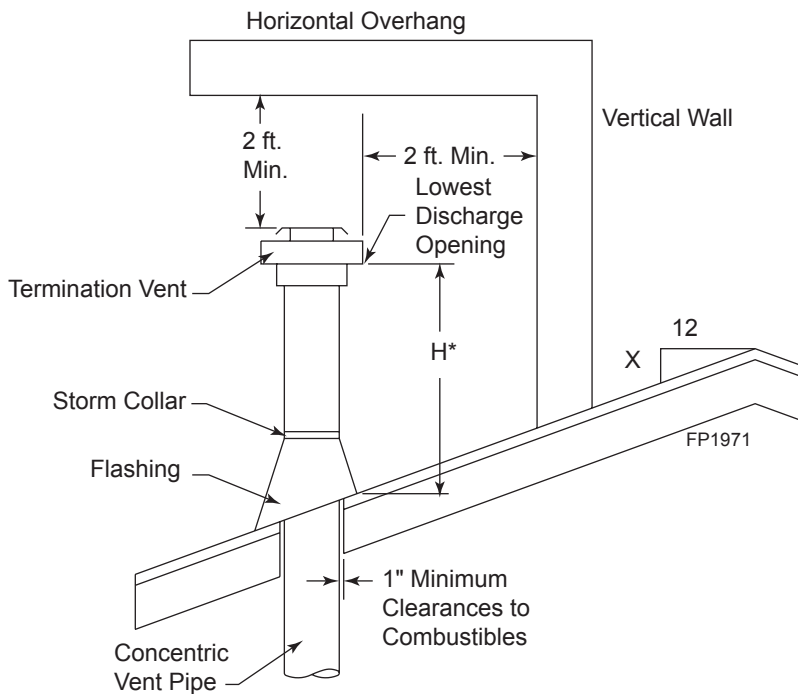

Roof Pitch	H (feet)
Flat to 6/12	1.0
Over 6/12 to 7/12	1.25
Over 7/12 to 8/12	1.5
Over 8/12 to 9/12	2.0
Over 9/12 to 10/12	2.5
Over 10/12 to 11/12	3.25
Over 11/12 to 12/12	4.0

*H - Minimum height from roof to lowest discharge opening of vent

Figure 23 - Minimum Chimney Clearance

CHECK GAS TYPE

Use proper gas type for the fireplace you are installing. If you have conflicting gas type, do not install fireplace. See dealer where you purchased the fireplace for proper fireplace for your gas type or conversion kit.

INSTALLING GAS PIPING TO FIREPLACE / BURNER SYSTEM LOCATION

WARNING
A qualified installer or service person must connect appliance to gas supply. Follow all local codes.

CAUTION
For propane/LP units, never connect fireplace directly to the propane/LP supply. This burner system requires an external regulator (not supplied). Install the external regulator between the burner system and propane/LP supply.

INSTALLATION ITEMS NEEDED

Before installing fireplace and burner system, make sure you have the items listed below.

- External regulator (supplied by installer)
- Sealant (resistant to propane/LP gas)
- Sediment trap (recommended)
- Tee joint
- Approved flexible gas line with gas connector (if allowed by local codes — not provided)
- Piping (check local codes)
- Test gauge connection*
- Pipe wrench
- Equipment shutoff valve*

* A CSA design-certified equipment shutoff valve with 1/8" NPT tap is an acceptable alternative to test gauge connection. Purchase the CSA design-certified equipment shutoff valve from your dealer.

For propane/LP connections only, the installer must supply an external regulator. The external regulator will reduce incoming gas pressure. You must reduce incoming gas pressure to between 11 and 13 inches of water. If you do not reduce incoming gas pressure, burner system regulator damage could occur. Install external regulator with the vent pointing down as shown in *Figure 24*. Pointing the vent down protects it from freezing rain or sleet.

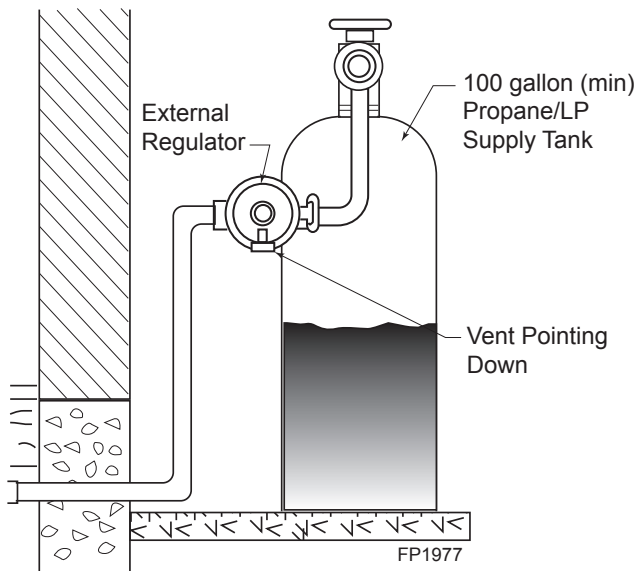

Figure 24 - External Regulator with Vent Pointing Down (Propane/LP Only)

CAUTION
Use only new black iron or steel pipe. Internally tinned copper or copper tubing can be used per National Fuel Code, section 2.6.3, providing gas meets hydrogen sulfide limits, and where permitted by local codes. Gas piping system must be sized to provide minimum inlet pressure (listed on data plate) at the maximum flow rate (BTU/hr). Undue pressure loss will occur if the pipe is too small.

When using copper or flex connectors use only fittings approved for gas connections. The gas control inlet is 3/8" NPT.

WARNING Only persons licensed to work with gas piping may make the necessary gas connections to this appliance.

CAUTION A manual shutoff valve must be installed upstream of the appliance. Union tee and plugged 1/8" NPT pressure tapping point should be installed upstream of the appliance. *Figure 24*

NOTE: The gas line connection may be made using 1/2" rigid tubing or an approved flex connector. Since some municipalities have additional local codes it is always best to consult your local authorities and the current edition of the National Fuel Gas Code ANSI.Z223.1, NFPA54. In Canada CSA-B149 (1 or 2) Installation Code.

A listed manual shutoff valve must be installed upstream of the appliance. Union tee and plugged 1/8" NPT pressure tapping point should be installed upstream of the appliance. *Figure 25*

CAUTION Use pipe joint sealant that is resistant to liquid petroleum (LP) gas.

IMPORTANT: Install main gas valve (equipment shutoff valve) in an accessible location. The main gas valve is for turning on or shutting off the gas to the fireplace.

Check your building codes for any special requirements for locating equipment shutoff valve to fireplaces.

Apply pipe joint sealant lightly to male threads. This will prevent excess sealant from going into pipe. Excess sealant in pipe could result in clogged burner system valves.

We recommend that you install a sediment trap/drip leg in supply line as shown in *Figure 25*. Locate sediment trap/drip leg where it is within reach for cleaning. Install in piping system between fuel supply and burner system. Locate sediment trap/drip leg where trapped matter is not likely to freeze. A sediment trap collects moisture and contaminants and keeps them from going into the burner system gas controls. If sediment trap/drip leg is not installed or is installed wrong, burner system may not run properly.

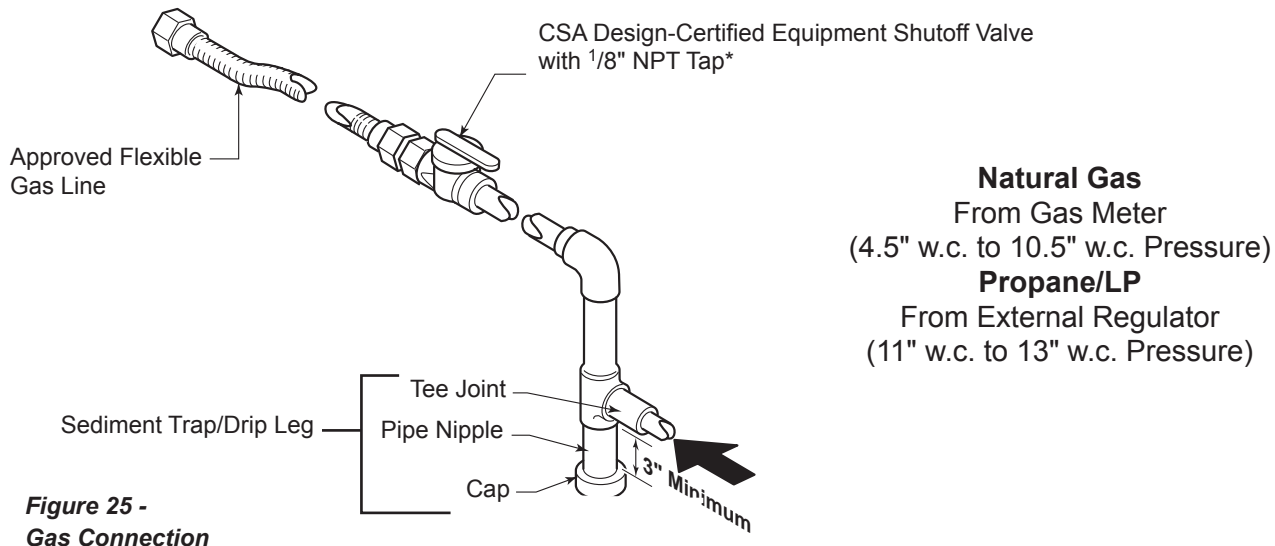
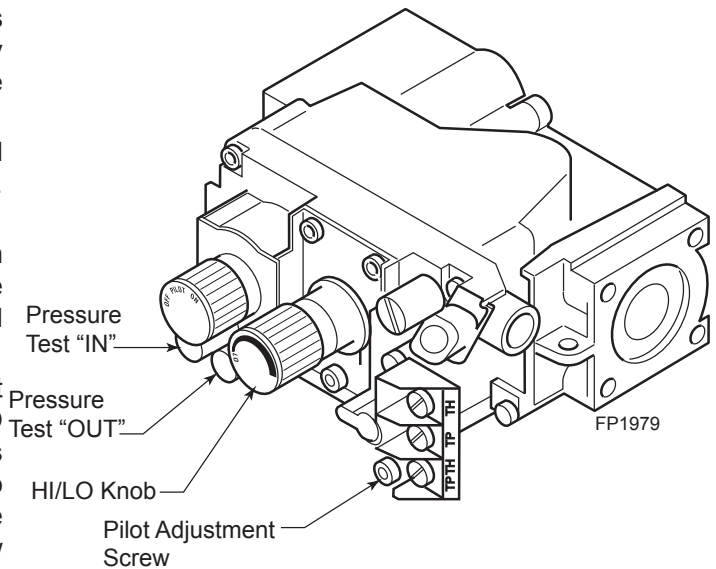

Figure 25 - Gas Connection

MILLIVOLT - CHECKING GAS PRESSURE and ELECTRICAL INSTALLATION

1. Check gas type. The gas supply must be the same as stated on the appliance's rating decal. If the gas supply is different from the fireplace, **STOP!** Do not install the appliance. Contact your dealer immediately.
2. To ease installation, a 24" (610 mm) flex line with manual shut-off valve has been provided with on this appliance. Install and attach $\frac{3}{8}$ " gas line onto shut-off valve.
3. After completing gas line connection, purge air from gas line and test all gas joints from the gas meter to the fireplace for leaks. Use a solution of 50/50 water and soap solution or a gas sniffer.
4. To adjust flame height, turn HI/LO knob to HI to get maximum pressure to burner. Turn HI/LO knob to LO to get minimum pressure. **NOTE:** To make the process of checking the gas pressure easier, unfasten the two screws which secure the gas valve to the side of the firebox and bring forward. [Remove the glass to allow the valve to come forward. (Refer to Page 45 for glass removal.)] When done, you must refasten the gas valve into place.
5. To check gas pressures at valve, turn captured screw counter clockwise 2 or 3 turns and then place tubing to pressure gauge over test point. Turn unit to high. *Figure 26.* After taking pressure reading, be sure and turn captured screw clockwise firmly to reseal. Do not over torque. Check test points for gas leaks.



**Figure 26 -
Gas Pressure Check at Gas Valve**

WARNING

Do not use open flame to check for gas leaks.

ELECTRICAL WIRING

This fireplace will work without any electrical supply. Electricity is only needed to operate the blower and the light located behind the logs inside the firebox.

NOTE: If installed in mobile home, fireplace must be bolted securely to floor.

Verify proper operation after servicing.

WARNING

Electrical connections should only be performed by a qualified, licensed electrician. Main power must be off when connecting to main electrical power supply or performing service. All wiring shall be in compliance with all local, city, and state codes. The appliance, when installed, must be electrically grounded in accordance with local codes, or in the absence of local codes, with the *National Electrical Code ANSI/NFPA 70 (latest edition)* and *Canadian Electrical Code, CSA C22.1*.

CAUTION

Label all wires before disconnecting when servicing controls. Wiring errors can cause improper and dangerous operation.

REMOTE WALL MOUNTED SWITCH

A remote wall switch and up to fifteen (15) feet of 18 Ga. wire may be used with this appliance. Attach the wall switch in a junction box at the desired location on the wall. *Figure 27*. Do not extend beyond the wall switch wire length provided.

NOTE: Extended lengths of wire may cause the fireplace not to function properly. Longer length of wire is permitted if the wire is made out of larger gauge (diameter) wire. Always check with local code.

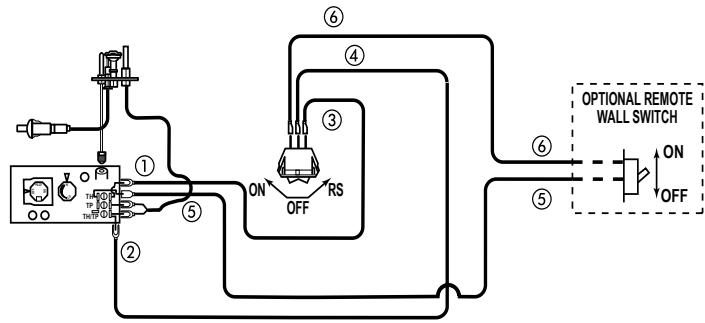

Figure 27 -
Wiring Diagram for Wall Switch

WARNING

Do not connect wall switch to a 110V circuit.

CAUTION

Electrical connections should only be performed by a qualified, licensed electrician. Main power supply must be turned off before connecting fans to the main electrical power supply or performing service.

OPTIONAL FAN/BLOWER SYSTEM (BLOTKHL)

IMPORTANT: Always check local building codes. This installation must comply with local regulations as well as the National Electric Code.

WIRING

1. Before installing the blower, wire the receptacle into an electrical circuit. This should be done before framing the fireplace. Wire with minimum 60°C wire in accordance with prevailing codes.
2. Remove the external junction box cover by removing the screw from the right side of the outside firebox wall. Junction box was installed at the factory.
3. The junction box cover has a factory installed "romex" style strain relief connector. After connecting the wires, route the wire leads through this connector. Refer to the wiring diagram in *Figure 29*.

BEFORE INSTALLING BLOWER

1. **Always turn off the gas supply and allow the unit to cool before proceeding.**
2. Clean the inside of the firebox (wall and floor), where the blower and wires will be installed. Make sure the firebox wall and floor are clean and dry before mounting the blower.

NOTE: It is very important to arrange the blower wires and wire assembly so that wires do not come in contact with blower blades or firebox.

WARNING

Before installing the blower, turn off the fireplace and allow to cool. Only a qualified service person should service and repair the fireplace. A qualified service person should connect and disconnect the fireplace to gas supply. Follow all local codes.

INSTALLING BLOWERS

1. Remove screen rod assemblies by lifting rod and pushing back and down to release rod from the three hooks located behind the face of the fireplace on the right, left, and middle.
2. Remove the plate located in front of the glass at the bottom.
3. Rotate the access doors on the right and left side of the glass toward the glass.
4. Remove glass frame by releasing the three latches located at the top of the firebox. Tilt glass away from the unit, lift glass frame up and away from the unit. *Page 45*
5. Remove logs.
6. Remove hearth brick, wall brick and rear brick. **NOTE: Remove brackets that secure wall brick.**

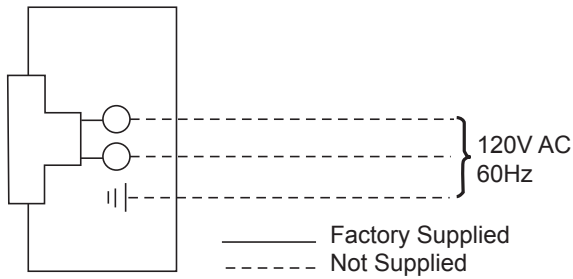

Junction Box
Figure 28 -
Junction Box Wiring Diagram

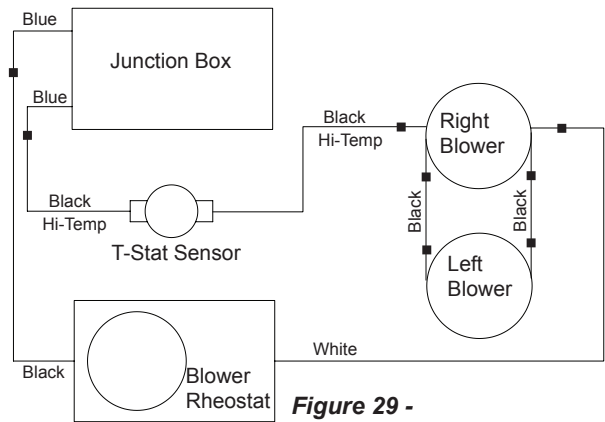

Figure 29 -
Blower Wiring Diagram

7. Remove the access covers on the right and left side walls of the firebox toward the front by unfastening the screws. **NOTE: The access covers are not identical.** *Figure 31*
8. Two screws are already mounted to each cover which would be utilized to mount the blower to the cover. Unfasten the two screws and mount the blower bracket assemblies. *Figure 33*
9. Consult blower wiring diagram and start the assembly. *Figures 28 & 29* It is helpful to wire the right blower, the speed control, the fan limit switch, and the power cord first. Then plug in the power cord to the junction box and secure the right cover plate/blower assembly to the side of the firebox.
10. Assemble the wire clips provided with the blower kit to the right and left sides of the fireplace through existing holes on right and left.
11. Run the wire harness down the right and snap wires into the clips assembled in #10. Run the two wires along the glass track, on the floor of the unit, in front of the firebox
12. Snap the fan limit switch behind the clip already assembled to the side of the firebox on the front right hand side. *Figure 32*
13. Secure the left access plate/blower assembly to the left side of the firebox. Run the two wires mentioned earlier up the left firebox wall and snap wires into clip assembled in #10 on the outer shell wall. Make the connection to the left blower. Replace the refractory and hearth refractory (pull away from burner toward the front).
14. Replace side panels attached to the glass frame assembly with the louvered side panels provided with the blower kit by unfastening the four nuts for each cover door. (Do not overtighten or stud may break off.) Use three metal clip screws provided with kit to secure the wire assembly in the front beneath the access cover. *Page 13, Figure 7*
15. Install the speed control (rheostat switch) on the side above the existing one used for the light (discard the plate sent with the switch as it will not be needed).
16. Replace logs.
17. Replace the glass.
18. Replace the front plate below the glass frame. **NOTE: The front plate hides the wire harness in the front.**

WARNING Failure to replace the access cover with the one provided with the blower kit, and then running the blower, will cause excessive temperatures and could cause a fire, property damage and/or loss of life.

WARNING Electrical Grounding Instructions: This appliance is equipped with a three-prong (grounding) plug for your protection against shock hazard and should be plugged directly into a properly grounded three prong receptacle.

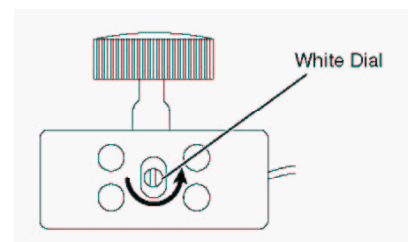
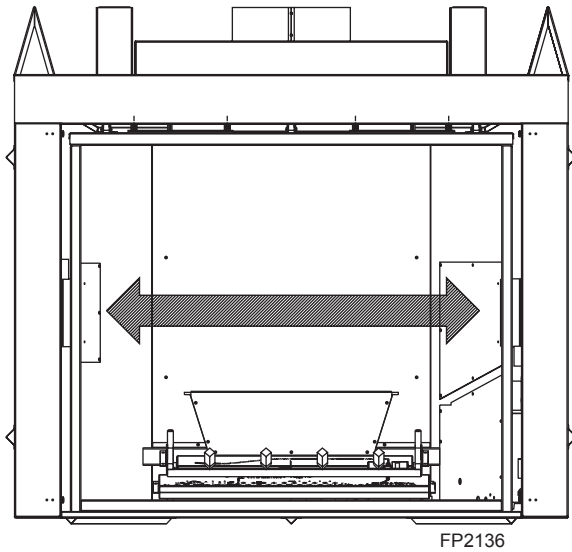
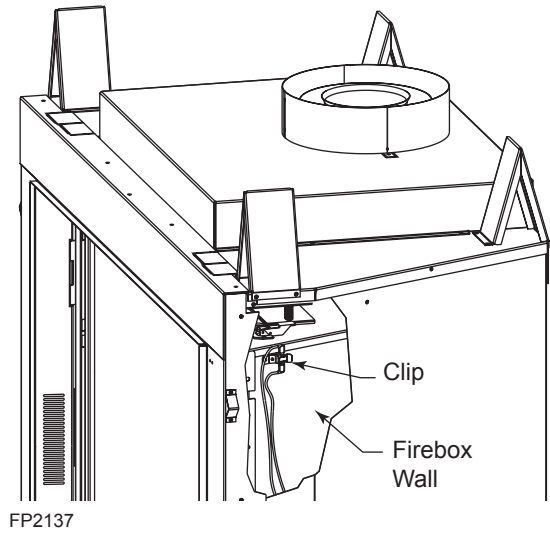

Figure 30 -
Location of White Dial on
Speed Control



**Figure 31 -
Blower Access Covers**



**Figure 32 -
Blower Access Covers**

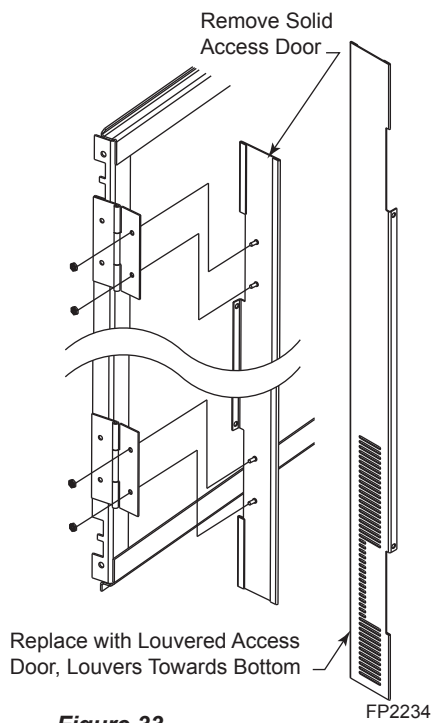

**Figure 33 -
Install New Louvers**

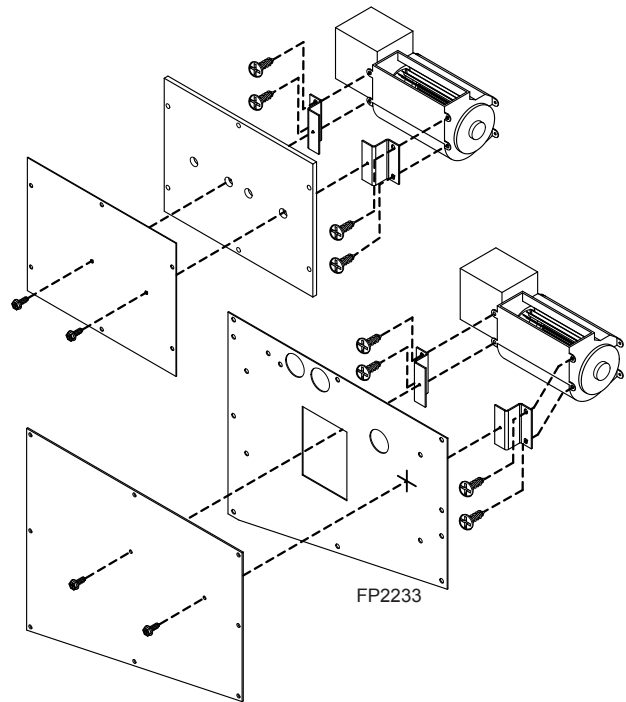

**Figure 34 -
Attach Blowers to Brackets**

FOR YOUR SAFETY READ BEFORE LIGHTING**WARNING**

If you do not follow these instructions exactly, a fire or explosion may result causing property damage, personal injury or loss of life.

- A. This appliance is equipped with a pilot which must be lit with built-in piezo ignitor while following these instructions exactly.
- B. BEFORE OPERATING smell all around the appliance area for gas. Be sure to smell next to the floor because some gas is heavier than air and will settle on the floor.

WHAT TO DO IF YOU SMELL GAS:

- Turn off all gas to the appliance.
 - Open windows.
 - Do not attempt to light any appliance.
 - Do not touch any electric switch; do not use any phone in your building.
 - Immediately call your gas supplier from a neighbor's phone. Follow the gas supplier's instructions.
 - If you cannot reach your gas supplier, call the fire department.
- C. Use only your hand to push in, or turn the gas control knob. Never use tools. If the knob will not push in or turn by hand, don't try to repair it. Call a qualified service technician. Force or attempted repair may result in a fire or explosion.
 - D. Do not use this appliance if any part of it has been under water. Immediately call a qualified service technician to inspect the appliance and to replace any part of the control system and any gas control that has been under water.

LIGHTING PILOT FOR THE FIRST TIME**INITIAL LIGHTING**

Purge air from the supply line as follows:

- Open main shutoff valve.
- Unscrew main pressure test point.
- Leave inlet test screw open until gas comes in.
- When gas is flowing, tighten inlet screw immediately.

WARNING

Never use an open flame to check for gas leak.

LEAK TESTING

1. Follow the pipe from the gas supply line connection to the gas valve. Check connection for leaks with soap and water mixture.
2. Next check for gas leaks at the burner with soap and water mixture.
3. Check the pilot for gas leaks with soap and water mixture.

LIGHTING PILOT FOR THE FIRST TIME

APPROVED LEAK TESTING METHOD

You may check for gas leaks with the following methods only:

- Soap and water solution
- An approved leak testing spray
- Electronic sniffer

DANGER

Never check for gas leak with open flame!

WARNING

If using a soap and water solution to test for leaks, **DO NOT** spray solution onto control body.

NOTE: Remove any excessive pipe compound from the connections. Excessive pipe compound can set off electronic sniffers.

Check for gas leaks in each of the following locations:

- Pipe from the gas supply line connection to the gas valve
- Burner connections
- Pilot
- Each joint or connection
- Field made joints / gas shutoff valve
- Factory made joints
- All joints on valve and control body

LIGHTING PILOT

WARNING

The control has an interlock device that does not allow the lighting of the fireplace up to the moment the safety device of the flame has not interrupted the gas flow. After that period of time (when the magnet is closed), it is possible to start the lighting operation.

The gas control knob is designed to be operated by hand. **DO NOT** use any tools during this operation. Damaged knobs may result in serious injury.

1. Depress and turn knob counterclockwise  to pilot position.
2. Depress fully and hold pilot gas knob. Depress piezo igniter as many times as needed to ignite pilot. Keep knob fully depressed for a few seconds. Release and check that pilot continues to burn.

If the pilot does not stay lit, repeat steps 1 and 2.

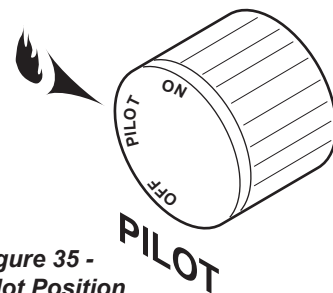

Figure 35 -
Pilot Position

Continued on next page

LIGHTING BURNER

MAIN BURNER SWITCH

The "ON/OFF/RS" switch for the main burner can be found behind door of the fireplace. This switch allows you to turn on and to turn off the main burner without using the gas valve knob. Make sure the button is in the "ON" position to light the main burner. *Figure 36*

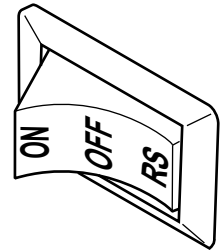



Figure 36 - On/Off/RS Switch

LIGHTING THE BURNER

Depress and turn the knob counterclockwise  to the "ON" position. *Figure 37*. It will take less than four (4) seconds for the burner to ignite.

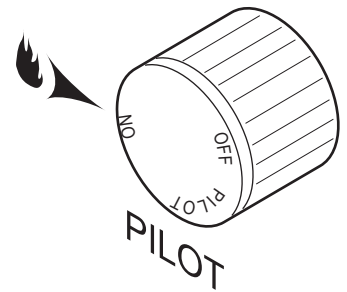

Figure 37- On Position

PILOT POSITION

Depress and turn knob to pilot position to keep burner off while maintaining the pilot light. *Figure 38*

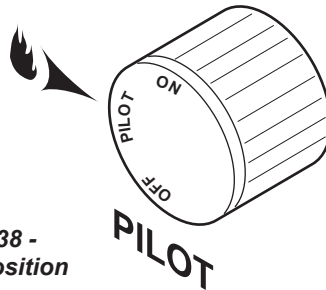

Figure 38 - Pilot Position

TO TURN OFF GAS

Depress and turn knob clockwise  to "OFF" position. *Figure 39*

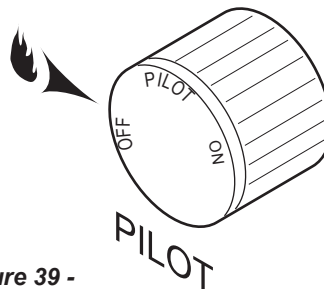
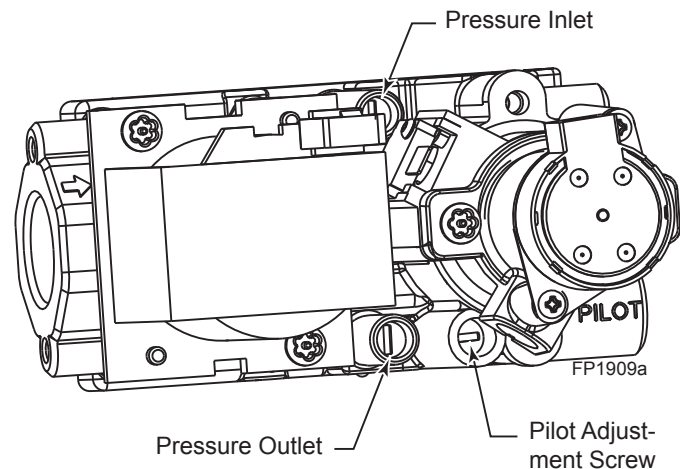

Figure 39 - Off Position

SIGNATURE COMMAND - CHECK GAS PRESSURE and ELECTRICAL INSTALLATION

1. Check gas type. The gas supply must be the same as stated on the appliance's rating decal. If the gas supply is different from the fireplace, **STOP!** Do not install the appliance. Contact your dealer immediately.
2. To ease installation, a 24" (610 mm) flex line with manual shut-off valve has been provided with on this appliance. Install and attach 1/2" gas line onto shut-off valve.
3. After completing gas line connection, purge air from gas line and test all gas joints from the gas meter to the fireplace for leaks. Use a solution of 50/50 water and soap solution or a gas sniffer.
4. To check gas pressures at valve, turn captured screw counter clockwise 2 or 3 turns and then place tubing to pressure gauge over test point. Turn unit to high. *Figure 40* After taking pressure reading, be sure and turn captured screw clockwise firmly to reseal. Do not over torque. Check test points for gas leaks.



**Figure 40 -
Signature Command Valve**

WARNING

Do not use open flame to check for gas leaks.

ELECTRICAL WIRING

This fireplace will work without any electrical supply. Electricity is only needed to operate blower.

NOTE: If installed in mobile home, fireplace must be bolted securely to floor.

Verify proper operation after servicing.

WARNING

Electrical connections should only be performed by a qualified, licensed electrician. Main power must be off when connecting to main electrical power supply or performing service. All wiring shall be in compliance with all local, city, and state codes. The appliance, when installed, must be electrically grounded in accordance with local codes, or in the absence of local codes, with the *National Electrical Code ANSI/ NFPA 70 (latest edition)* and *Canadian Electrical Code, CSA C22.1*.

CAUTION

Label all wires before disconnecting when servicing controls. Wiring errors can cause improper and dangerous operation.

SIGNATURE COMMAND OPTIONAL WALL COMMAND CENTER and BLOWER SYSTEM

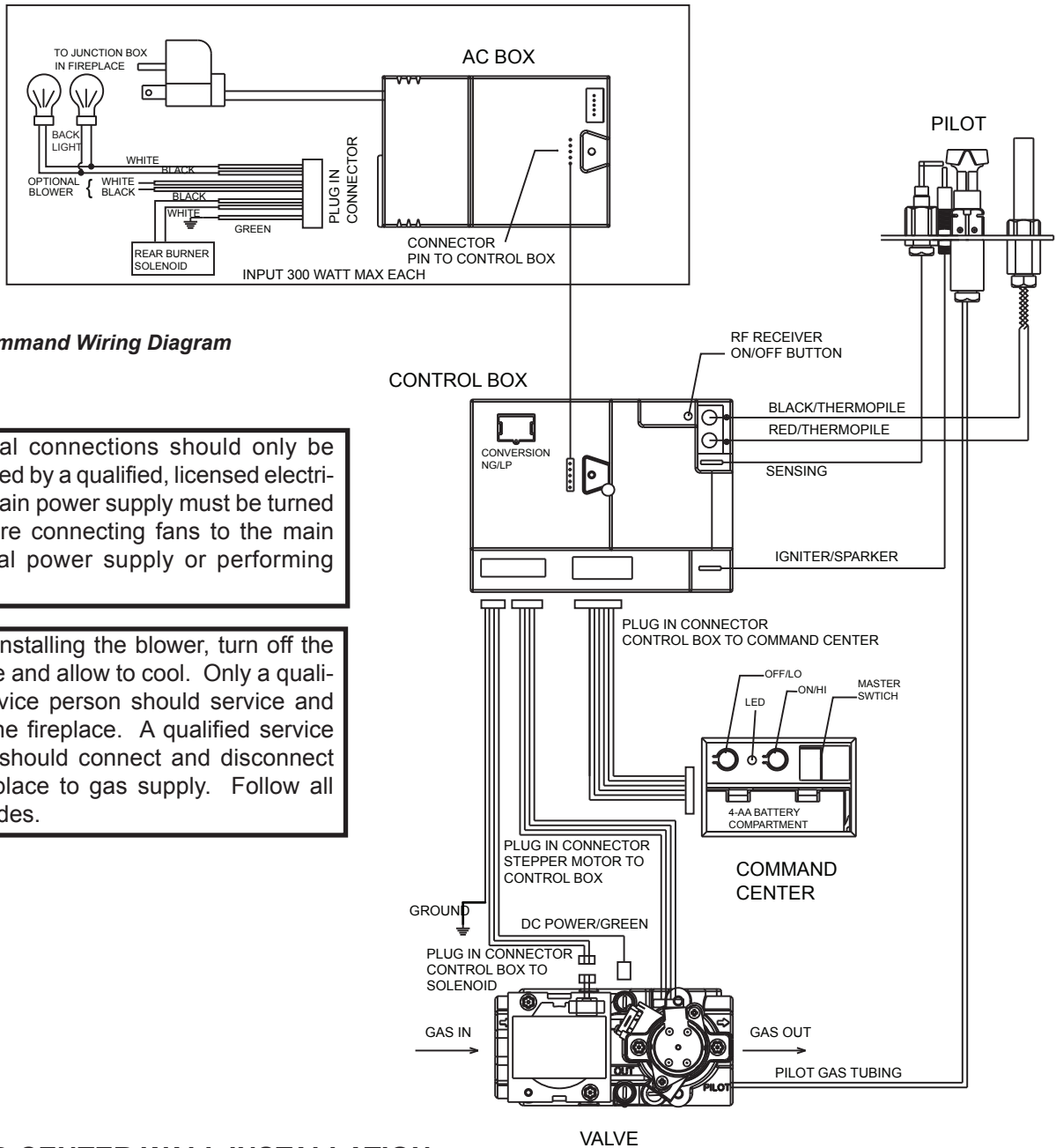

**Figure 41 -
Signature Command Wiring Diagram**

CAUTION

Electrical connections should only be performed by a qualified, licensed electrician. Main power supply must be turned off before connecting fans to the main electrical power supply or performing service.

WARNING

Before installing the blower, turn off the fireplace and allow to cool. Only a qualified service person should service and repair the fireplace. A qualified service person should connect and disconnect the fireplace to gas supply. Follow all local codes.

COMMAND CENTER WALL INSTALLATION

The Command Center may be mounted on the wall with the use of the SCSWEK Kit. (15' cable, junction box and wall cover).

Mount the junction box provided at the desired location on the wall. Do not extend beyond the 15' wire cable provided.

Route wire from junction box to lower control area at bottom of fireplace. Unplug the 12' cable from control box and command center. Plug the 15' extension cable into the control box. Remove command center from the fireplace and plug the other end of the extension cable into the command center. Snap on wall cover provided and screw to junction box.

OPTIONAL FAN/BLOWER SYSTEM (BLOTKHLSC)

IMPORTANT: Always check local building codes. This installation must comply with local regulations as well as the National Electric Code.

WIRING

1. Before installing the blower, wire the receptacle into an electrical circuit. This should be done before framing the fireplace. Wire with minimum 60° C wire in accordance with prevailing codes.
2. Remove the external junction box cover by removing the screw from the right side of the outside firebox wall. Junction box was installed at the factory.
3. The junction box cover has a factory installed “romex” style strain relief connector. After connecting the wires, route the wire leads through this connector. Refer to the wiring diagram in *Figure 43*.

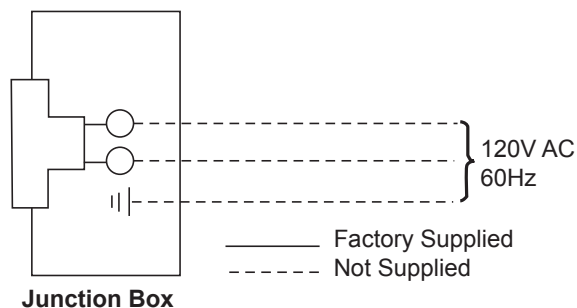

Junction Box

Figure 42 -
Junction Box Wiring Diagram

BEFORE INSTALLING BLOWER

Always turn off the gas supply and allow the unit to cool down before proceeding.

NOTE: It is very important to arrange the blower wires and wire assembly so that wires do not come in contact with blower blades or firebox.

INSTALLING BLOWERS

1. Remove screen rod assemblies by lifting rod and pushing back and down to release rod from the three hooks located behind the face of the fireplace on the right, left, and middle.
2. Remove the plate located in front of the glass at the bottom.
3. Rotate the access doors on the right and left side of the glass toward the glass.
4. Remove glass frame by releasing the three latches located at the top of the firebox. Tilt glass away from the unit, lift glass frame up and away from the unit. *Page 44*
5. Remove logs.
6. Remove hearth brick, wall brick and rear brick. **NOTE: Remove brackets that secure wall brick.**
7. Remove the access covers on the right and left side walls of the firebox toward the front by unfastening the screws. **NOTE: The access covers are not identical.** *Figure 45*
8. Two screws are already mounted to each cover which would be utilized to mount the blower to the plate. Unfasten the two screws and mount the blower bracket assemblies. *Figure 45*
9. Assemble the wire clips provided with the blower kit to the right and left sides of the fireplace through existing holes on right and left.
10. Run the wire harness down the right and snap wires into the clips assembled in #9. Run the two wires in front of the glass track, on the floor of the unit, in front of the firebox and secure with clips provided.
11. Secure the left access plate/blower assembly to the left side of the firebox. Run the two wires mentioned earlier up the left firebox wall and snap wires into clip assembled in #9 on the outer shell wall. Make the connection to the left blower. Replace the refractory and hearth refractory (pull away from burner toward the front).
12. Replace side panels attached to the glass frame assembly with the louvered side panels provided with the blower kit by unfastening the four nuts for each cover door. (Do not overtighten or stud may break off.) Use three metal clip screws provided with kit to secure the wire assembly in the front beneath the access cover. *Page 13, Figure 7*

WARNING

Before installing the blower, turn off the fireplace and allow to cool. Only a qualified service person should service and repair the fireplace. A qualified service person should connect and disconnect the fireplace to gas supply. Follow all local codes.

13. Connect the two (2) wiring harness wires to the wires marked (blower) from the AC Module and snap wires into clips from Step 9.
14. Replace logs.
15. Replace the glass.
16. Replace the front plate below the glass frame. **NOTE: The front plate hides the wire harness in the front.**

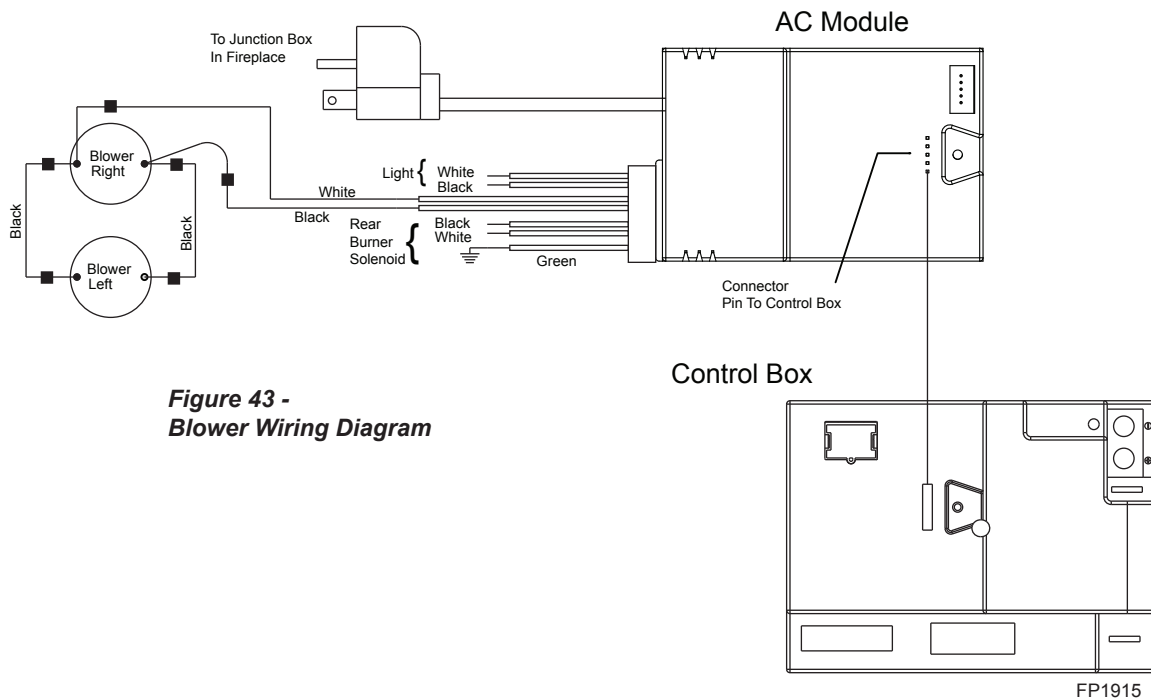

**Figure 43 -
Blower Wiring Diagram**

WARNING

Electrical Grounding Instructions: This appliance is equipped with a three-prong (grounding) plug for your protection against shock hazard and should be plugged directly into a properly grounded three prong receptacle.

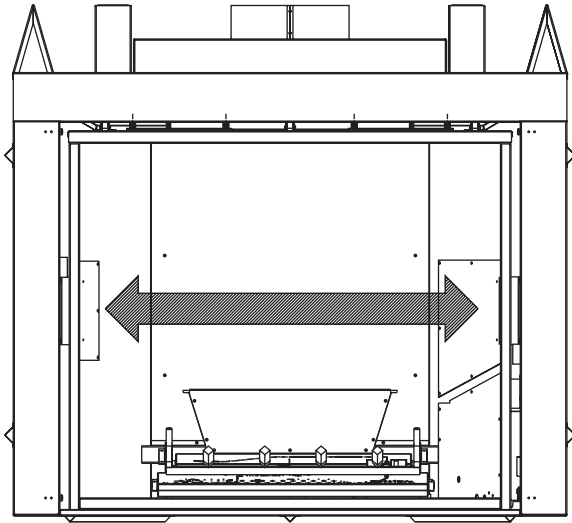

FP2136

**Figure 44 -
Blower Access Plates**

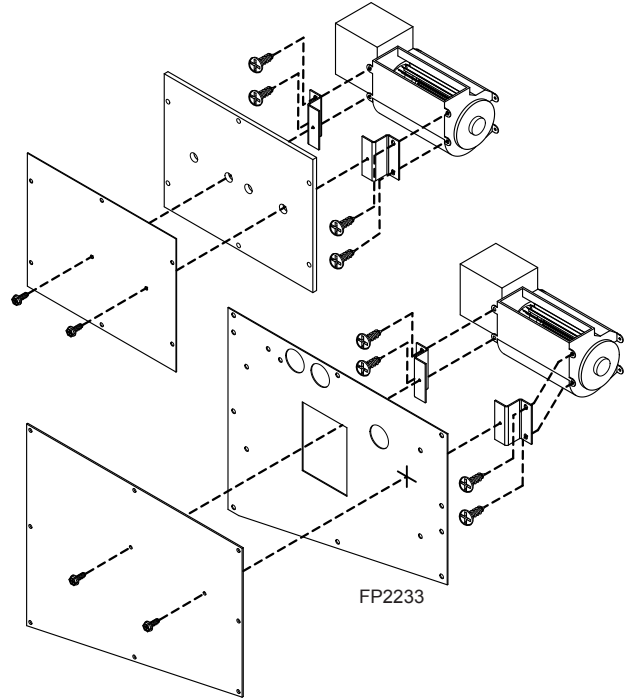

FP2233

**Figure 45 -
Attach Blowers to Brackets**

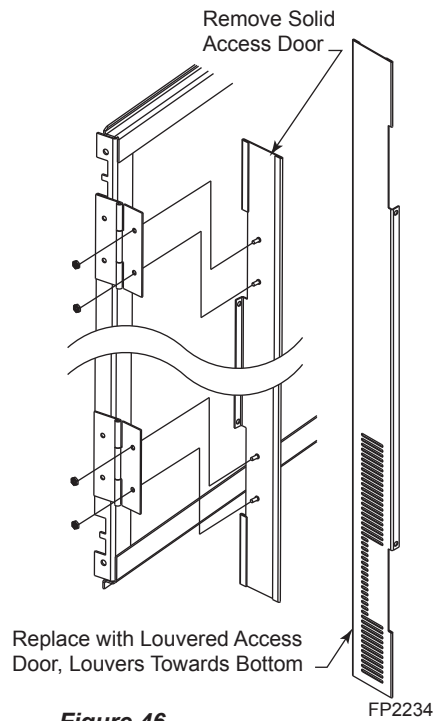

FP2234

**Figure 46 -
Install New Louvers**

FOR YOUR SAFETY READ BEFORE LIGHTING**WARNING**

If you do not follow these instructions exactly, a fire or explosion may result causing property damage, personal injury or loss of life.

- A.** This appliance is equipped with an ignition device which automatically lights the pilot. Refer to the instructions for match lighting.
- B.** BEFORE OPERATING smell all around the appliance area for gas. Be sure to smell next to the floor because some gas is heavier than air and will settle on the floor.

WHAT TO DO IF YOU SMELL GAS:

- Do not attempt to light any appliance.
 - Do not touch any electric switch; do not use any phone in your building.
 - Immediately call your gas supplier from a neighbor's phone. Follow the gas supplier's instructions.
 - If you cannot reach your gas supplier, call the fire department.
- C.** Use only your finger to push in the master switch. Never use tools. If the switch will not function by hand, do not try to repair it. Call a qualified service technician. Force or attempted repair may result in a fire or explosion.
- D.** Do not use this appliance if any part of it has been under water. Immediately call a qualified service technician to inspect the appliance and to replace any part of the control system and any gas control that has been under water.

continued on next page

OPERATING INSTRUCTIONS

1. **STOP!** Read the safety information above.
2. This appliance is equipped with an ignition device which automatically lights the burner. Do not try to light the burner by hand.
3. With five (5) minutes to clear out any gas. Then smell for gas, including near the floor. If you smell gas, **STOP!** Follow "B" in the safety information on Page 35. If you do not smell gas, go to next step.
4. Install four (4) "AA" batteries (provided in your Homeowner's Manual bag) into the command center box. Make sure the batteries orientation match.
5. Press the master switch to the "ON" (-) position. Within eight (8) seconds it will beep once. This indicates the system is ready.
6. Press "ON " button. Sparker will spark and pilot flame will light.
7. Once pilot flame is established, the main burner flame will light automatically.
8. If the pilot will not stay lit after several tries, turn the master switch to "OFF" and call your service technician or gas supplier.

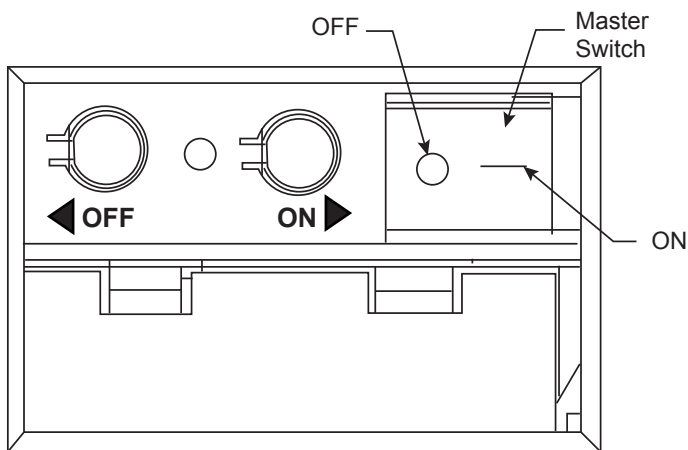

Switch Box

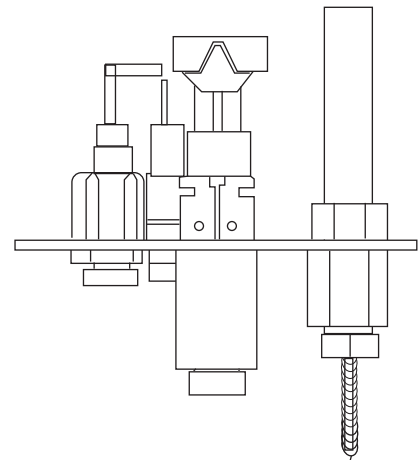

TO TURN OFF GAS TO APPLIANCE

1. Turn master switch to "OFF".
2. Turn off all electrical power to the appliance if service is to be performed.

FEATURES

Command Center

- Easy Access Function Operation and System Configuration
- Operation Confirmation/Fault Diagnostic Indications (LED/ Buzzer)
- ON/OFF/Hi/Low Operation

Control Board

- Electronic Ignition
- Pilot Lockout safety feature
- Electric Power Regeneration from Thermopile to save battery
- 6-hour Automatic Shut Down Option
- Convenient NG/LP Gas Type Conversion
- Standing Pilot/Intermittent pilot Conversion
- Previous settings Restoration Ability
- Uninterrupted Operation During Power Outage (Automatic Battery Backup)
- ON/OFF RF Remote Receiver
- Optional Transmitter Learn Capability

AC Module

- Easy Snap-on Design
- Embedded Compact 120 V AC Adapter with Auto Battery Back up Feature
- Remote Controlled Blower, Lighting, and Auxiliary AC Outputs

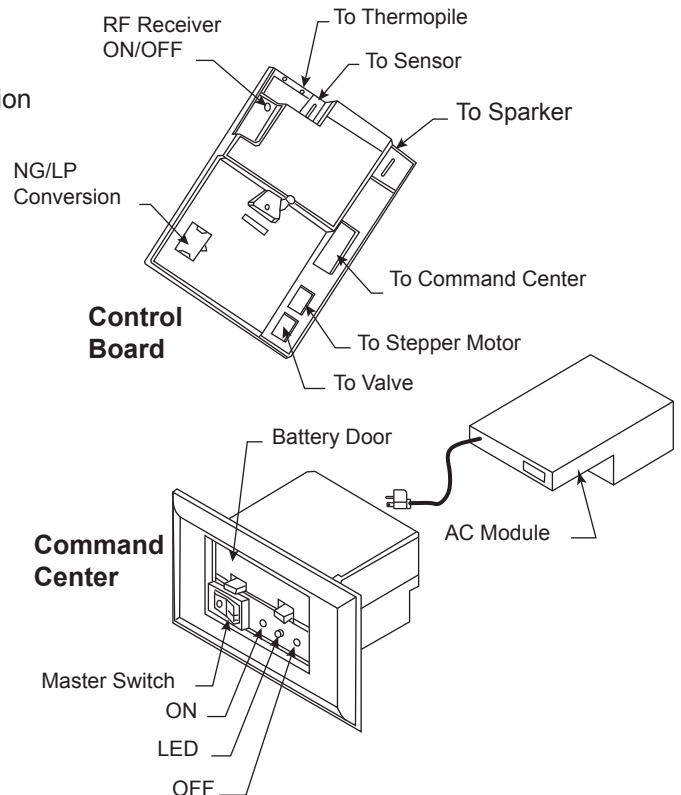

Figure 47 - Signature Command System Components

Transmitter

RFSC

Three Flame Height Settings	X
Low battery Indication for Transmitter	X
Child Proof Lock-out	X
LCD Backlight	X
Security Codes	X
Thermostatic Control Mode	X
Three Brightness Settings for Lights	X
Three Speed Control for Blower	X
On/Off Rear Burner Control	X
Programmable Timer to turn blower on and off	X

BATTERY INSTALLATION

The Command Center uses four (4) "AA" batteries.

To Install Batteries:

1. Press down the battery door tabs and pull out to remove battery door.
2. Install the batteries as indicated on Command Center.
3. Close battery door by snapping in place.
4. When the four (4) batteries are installed the system is ready for use.
5. The batteries should be replaced when the LED indicates low battery.

SYSTEM CONFIGURATION/SETUP

System configuration/setup is done on the Command Center.

Intermittent/Standing Pilot Setup (Default intermittent)

1. Holding the ON button on the Command Center while turning on the master switch will toggle between standing pilot and intermittent pilot.
2. After the above operation, one beep (for standing pilot) or two beeps (for intermittent pilot) will be given as confirmation.

Six-hour Safety Shutdown Option (Default ON)

1. The system comes preset from the factory with a six (6) hour shutdown from its last command of operation. This is done to prevent the fireplace from continuing to operate if unattended. You may disable this feature if you wish.

NOTE: By disabling this feature, your fireplace may continue to operate unattended.

2. When the master switch is in the ON position ("–"), pressing the ON button and the OFF button on the Command Center simultaneously will toggle between enabling and disabling the six-hour shutdown option.
3. After the above operation, one beep (for enabling the six-hour shutdown option) or two beeps (for disabling the six-hour shutdown option) will be given as confirmation.

Remote Transmitter Learn Function (Default ON)

1. The RF receiver button located on the control board must be in the on position before the learn function can begin. Use paper clip to depress button. One beep for RF receiver ON or two beeps for RF receiver OFF will be given as confirmation.
2. After the RF receiver is ON, holding the OFF button on the Command Center while turning on the master switch will activate the learn function for the transmitter.
3. After the above operation, two beeps will be given and the green LED on the Command Center will flash for 10 seconds.
4. During the 10 seconds, press the OFF button on a transmitter to learn. Another two beeps will be given to confirm a successful learning.

Shutting Off the Standing Pilot

To shut off the standing pilot for service or summer shut down, press and hold the ON button on the Command Center for 3 seconds when the master switch is in the ON position ("–") and the main burner is off.

Note: Pilot will resume the next time system is turned on.

Key Combinations for System Settings

Function	Operation	Default Setting
Intermittent/Standing Pilot Setup	Hold the ON ▲ button while turning on the master switch (Beep once for standing pilot, twice for intermittent pilot)	Intermittent Pilot
Standing Pilot Temp. Shutoff	Hold the ON ▲ button 3 seconds (when the master switch on the main burner is off)	
RF Remote Receiver On/Off	Push the RF receiver On/Off button on the control board Beep once for ON and beep twice for OFF	RF ON
Learn Remote Transmitter	Hold the OFF ▼ button while turning on the master switch (Beep twice then press any handheld remote button)	
6-hour safety shutdown setup	Press the ON ▲ button and OFF ▼ button simultaneously (Beep once for ON, twice for OFF)	ON

COMMAND CENTER FUNCTIONS/OPERATION**Turning on the fireplace**

1. Turn on the master switch and wait for a beep.
2. Press the ON button on the Command Center. Pilot will light and burner will come on High setting.

Pilot Safety Lockout Function

1. If the pilot doesn't light after sparking for 30 seconds, pilot trial lockout happens. The LED on the Command Center flashes Green once every 2 seconds, until reset.
2. If the pilot flame is lost during normal operation, flame loss lockout happens. The LED on the Command Center flashes Red-Green once every 2 seconds, until reset.
3. Turning the master switch OFF, then ON again will reset the system.

Flame Height Control

1. Press the ON button (on the Command Center) once to turn on the main burner with maximum flame height.
2. Press the OFF button to decrease flame height. The first two presses will decrease the flame height to medium and low.
3. The third press on OFF will turn off the main burner. In standing pilot configuration, the pilot will stay; in intermittent pilot configuration, the pilot will be shut off.

Turning the Fireplace Off

There are three ways to turn the fireplace off. (This will turn the entire system OFF.)

1. Flip the master switch to the off ("O") position
2. Press the OFF button to Medium, Low, then Off.
3. Hold the OFF button anytime for three seconds. This command of OFF will remember all last settings before turning off. The next time the fireplace is turned on, all settings will resume.

Command Center Operations:

The following functions are available on the Command Center.

Function	Operation
Power Up	Flip the master switch to the ON (" ") position to power up the system
Fireplace ON	Press the ON ▲ button on the Command Center to turn the fireplace on
Fireplace OFF	Flip the master switch to the OFF ("o") position OR press the OFF ▼ button 3 times OR hold the OFF ▼ button 3 seconds
Flame Height Up	Press the ON ▲ button once to turn on the fireplace with maximum flame height
Flame Height Down	Press the OFF ▼ button to lower the flame height to Medium and Low

Self Diagnostics Chart:

The Command Center has a self-diagnostic LED enabling you to troubleshoot problems and potentially avoid a service call. Please refer to the charts below for indicator reference.

Fault	LED Indication
Conversion Cover Missing	One RED (1 time)
Spark Fail	Two RED (1 time)
No Sensor Signal	Three RED (1 time)
Pilot Lockout - trial	One GREEN, every 2 sec. (until manual reset)
Pilot Lockout - flame loss	One RED-GREEN, every 2 sec. (until manual reset)
Low Battery	One RED, every 10s (continuously)
No or Low Thermopile Power	Two RED, every 10s (continuously)
Learning	GREEN Flashes, every 1 sec. (for 10 sec.)
AC Power On	GREEN solid

REMOTE TRANSMITTER OPERATIONS

General

Figure 48

The RFSC Remote Control has two (2) operating modes: Manual and Thermostatic. The control system can be set to a temperature range between 45° F and 90° F. The blower speed, light, rear burner shut down and flame height can be adjusted in either the manual and thermostatic mode.

The transmitter will operate the remote receiver from 12" to a maximum of 30'. **NOTE:** The distance decreases when the batteries are low.

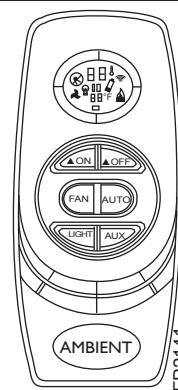

Figure 48 - Remote Transmitter

Initial Startup

Figure 49

1. After initial power up or when RESET button is pressed, the transmitter is reset. The reset button is located behind the battery door of transmitter.
2. During system reset, all features of the LCD DISPLAY will be visible. After one second, the LCD will be initialized. A typical reset display is shown in Figure 49. Note that the temperature scale is degree F.
3. Press ON button to select between °C and °F display. It will exit setting mode automatically after 10 seconds if no key is pressed. The transmitter will send an OFF signal after reset.
4. After reset, the transmitter is operating in manual mode. The room temperature is shown.

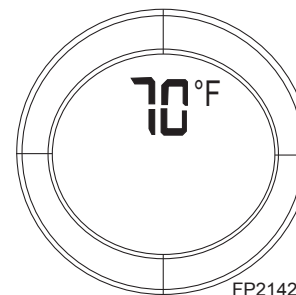

Figure 49 - Typical Reset Display

Manual Mode

Figure 50

1. Press the ON button once to turn on the appliance with max flame height.
2. Press the OFF button to decrease flame height. The first two (2) presses will decrease flame height to lower level. The third press will turn off the fireplace.
3. If OFF button is held for more than three (3) seconds, the fireplace will be shut off and remembers the last flame height setting. It will also remember light and auxiliary settings. To reset, change setting and hold OFF button for 3 seconds. New setting is now remembered.

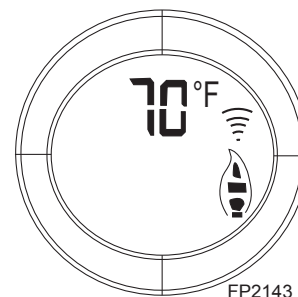

Figure 50 - Manual Mode

Thermostatic Mode

Figure 51

1. Press the AUTO button to enter the thermostatic mode. Figure 51
2. In thermostatic mode, press the ON / ▲ button or OFF / ▼ button to set the desired set temperature.
3. Once the setting is completed, the transmitter will automatically turn on the fireplace when the room temperature is below the set temperature and turn off the fireplace when the room temperature is above the set temperature within 1 degree.
4. There will be a slight delay in the response of the unit (on/off) to a temperature. Room temperature is monitored every three (3) minutes.
5. Press AUTO button to exit the thermostatic mode. The transmitter will be in the manual off mode and the fireplace will be shut off.

NOTE: When thermostat mode is used, the command center ON/OFF buttons will not function, only the master switch will function.

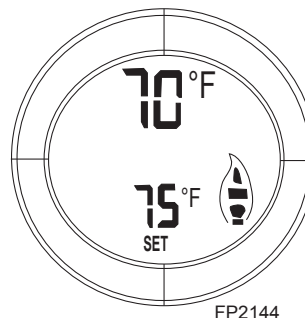
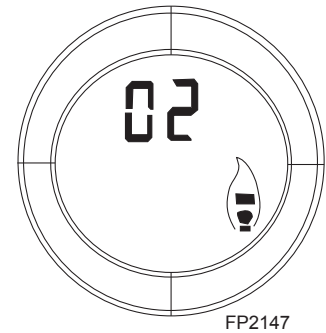

Figure 51 - Thermostatic Mode

Flame Height Setting for Thermostatic Mode

Figure 52

1. Hold AUTO button for five (5) seconds and one number and flame icon will appear in LCD screen.
2. Use the ON / ▲ or OFF / ▼ button to set the desired flame height to 1 (min.) 2 (medium) or 3 (max.).
3. If there is no input within three (3) seconds, the new setting will be transmitted to the receiver. This setting only affects auto mode operation.
4. The default setting for transmitter is 2 (medium).



**Figure 52 -
Flame Height Setting Display**

3-Speed Blower Control

Figure 53

NOTE: Blower works automatically with flame.

1. Press FAN button once to enter blower speed setup mode at low speed initially and one of the three blade icons will display darken on LCD display. *Figure 53*
2. Continue to press FAN button to set up the blower speed you desire.
3. If there is no input within three (3) seconds, the new setting will be transmitted to receiver. If the fireplace is on, the blower speed will take effect right away; if the fireplace is off, the receiver will remember this setting and blower is still off.
4. If you continue to press FAN button to the position that all blades are gone, the FAN icon will disappear and turn the blower off.

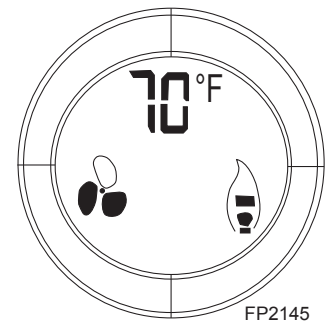
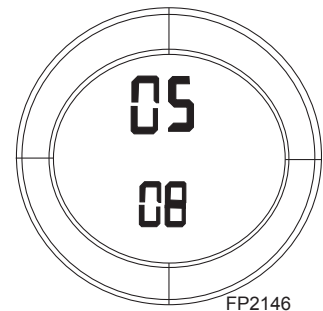

**Figure 53 -
3 Speed Blower Control**

Blower On Delay Time and OFF Delay Time Setting (Default 5 ON / 8 OFF)

Figure 54

1. Hold FAN button for three (3) seconds and two (2) numbers will appear in the LCD screen. The upper one is ON Delay Time and the bottom is OFF Delay Time in minutes.
2. Use the ON / ▲ button to set the desired On Delay Time from 0 to 15 minutes.
3. Use the OFF / ▼ button to set the desired Off Delay Time from 0 to 15 minutes.

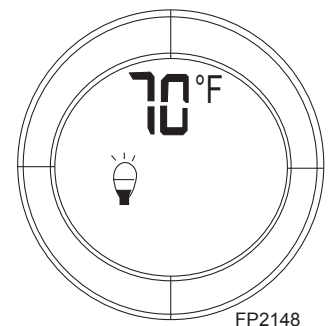

**Figure 54 -
Blower Delay Timer Display**

3-Level Light Brightness Control

Figure 55

1. Press LIGHT button once to change light brightness to low and one of the three levels will display dark on LCD.
2. Continue to press LIGHT button to set up the light brightness you desire.
3. If there is no input within three (3) seconds, the new setting will be transmitted to the receiver.
4. If you continue to press LIGHT button, the LIGHT icon will disappear and turn the light off.



**Figure 55 -
Light Brightness Display**

AUX Control (Rear Burner Shut Down)

Figure 56

1. Press AUX button once to turn rear burner off. AUX shows on the LCD.
2. Press AUX button again to turn on rear burner. AUX icon disappears.

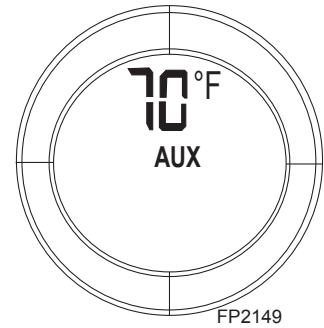

Figure 56 -
AUX Display

Low Battery Detection

Figure 57

1. Battery voltage is checked once a minute. When the battery voltage drops to a certain level, the low-battery icon will display on LCD, and the transmitter will turn off the fireplace. The transmitter will not function anymore until fresh batteries are installed.
2. When the batteries are low, the LCD displays a low battery indicator. The low battery indicator will be displayed in any mode.
3. The transmitter will not operate with low batteries. Change the batteries before the batteries are too weak for normal operation. Turn the unit OFF before replacing batteries.

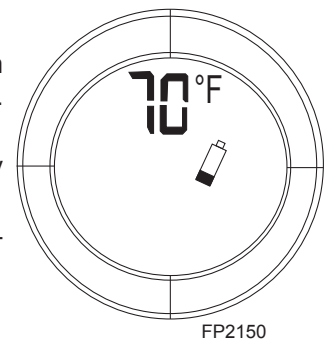

Figure 57 -
Low Battery Display

Child-Proof Protection

Figure 58

1. Press and hold the ON and OFF buttons simultaneously for three (3) seconds to enter child proof mode. Figure K
2. The transmitter will not send a signal again until the childproof mode is deactivated by pressing the ON and OFF buttons simultaneously for three (3) seconds to exit child proof mode and the Childproof indicator disappears from LCD.

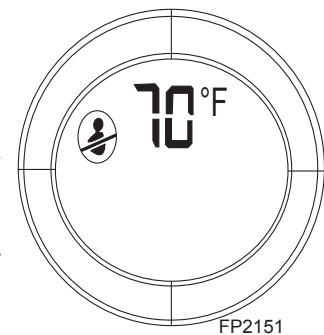

Figure 58 -
Child Protection Display

Transmitter Thermal Shutdown

Figure 59

1. If transmitter measures a room temperature exceeding 99° F, the LCD will display "HI" and the transmitter will turn off the fireplace.
2. Transmitter will not function until the room temperature has dropped below 99° F. If transmitter measures a room temperature less than 40° F, the LCD will display "LO" and NO SIGNAL will be sent to turn on the fireplace.

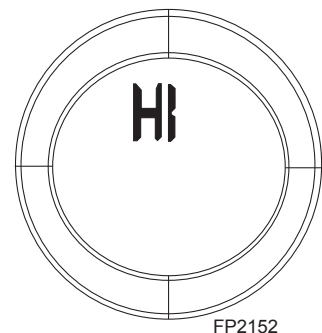
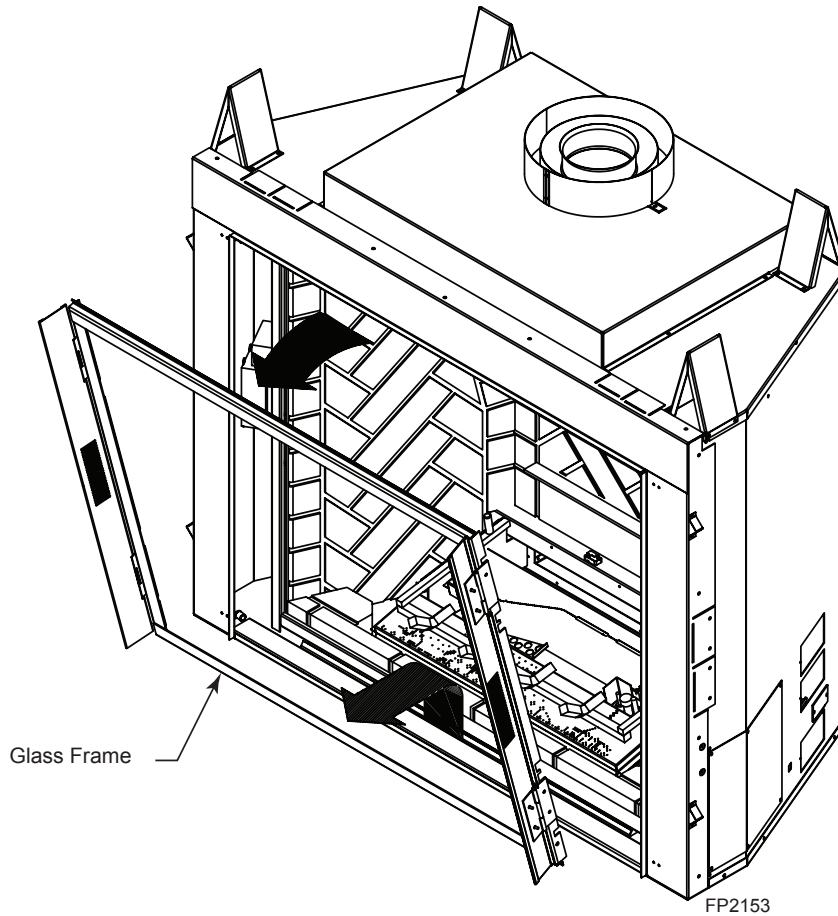

Figure 59 -
Thermal Shutdown Display

GLASS FRAME REMOVAL

1. Remove the plate located in front of the glass at the bottom.
2. Remove rod provided for screen assembly located beneath the cover plate.
3. Rotate the access doors on the right and left side of the glass toward the glass.
4. Remove glass frame by releasing the three latches located at the top of the firebox. Tilt glass away from the unit, lift glass frame up and away from the unit. *Figure 60*



**Figure 60 -
Remove Glass Frame**

CAUTION Each clamp has a quick spring force. When reinstalling clamps, keep fingers clear.

! WARNING



HOT GLASS WILL CAUSE BURNS.
DO NOT TOUCH GLASS UNTIL COOLED.
NEVER ALLOW CHILDREN TO TOUCH GLASS.

BRICK, LIGHT BULB, AND LENS PLACEMENT

1. Remove the trapezoidal light shroud located at the back of the firebox by unfastening the three screws.
2. Disassemble the trapezoidal light shroud by unfastening the four screws which secure the front to the back. Set lens with the orange painted surface toward the bottom. Center the lens right to left. Reassemble the front to the back and set the side.
3. Place the right side panel by sliding it at an angle to clear the grate. Set the panel straight up and bring forward until it comes in contact with the reverse bend located at the front of the firebox. Use one of the brackets and screws provided to secure the panel in place.
4. Place the rear lower panel by setting it over the channel behind the light socket. Make sure the grout line lines up with the one on the side.
5. **NOTE: Have the left panel bracket and screw handy before installing the rear upper panel in place.** Place the rear upper panel in place by resting it over the rear lower panel and sliding it behind the right side panel. While holding the rear upper panel in place, slide the left panel at an angle to clear the grate. Set the left side panel straight up and release the rear upper panel. Secure the left side panel in place using the second bracket and screw provided in the kit.
6. Place the front hearth brick simultaneously and pull toward the front away from the burner. This is critical for balancing air flow around the front burner.
7. Install the halogen light bulb provided with the unit (inside the log set). Do not touch light bulb directly with fingers.
8. Replace the trapezoidal light shroud removed in step #1 by sliding it over the light bulb and sockets. Be careful not to damage the light bulb. Align the holes on the deflector with the hole on the rear channel and secure in place.

WARNING

Do not use the entire bag of rock wool to cover the burner. This could cause the flame to burn poorly and may lead to sooting.

ROCK WOOL PLACEMENT

1. Place rock wool on the front burner to provide glowing embers. For best results, pull the rock wool apart into dime size pieces and place on top of burner. Also place the same size ember over the carry over parts on the rear burner. **Do NOT place embers over open slots on the rear burner.**
2. Distribute one layer of rock wool to cover the burner. *Figure 62*
3. Place the logs on the burner. See *Log Placement* below. Light unit and after 15 minutes, check burner flame and glow. Refer to *Burner Flame*, Page 50.

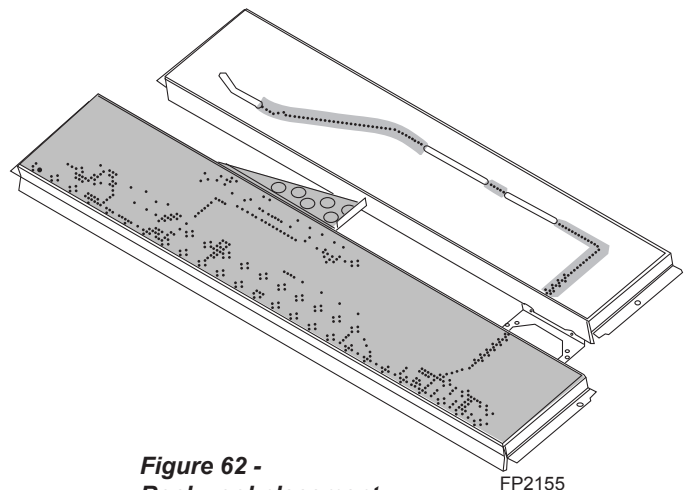

Figure 62 - Rockwool placement

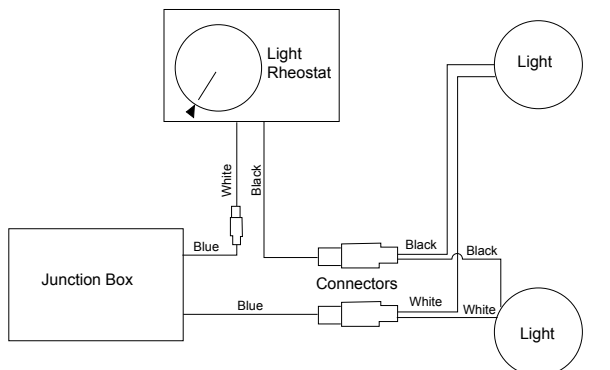

Figure 61 - Light Wiring Diagram for Millivolt Unit

LOG PLACEMENT



Burner Grate Assembly

LG593



Step 1

LG594

1. Place the rear log over the grate toward the back by positioning the holes over the large pins located at the right and left. When the log is in place, the back surface of the log will come in contact with the light trapezoid deflector.



Step 2

LG595

2. Place the log over the pilot by holding the log with the wide end toward the back and the branch toward the front and left. Set the log by having the protrusion on the bottom of the log rest to the left side of the grate bar and behind the pilot shield. Also set the notch located at the bottom of the left branch over the second right tong on the grate. Make sure that the log is positioned properly so it is not rocking. **NOTE: When the log is in place, it should not touch the pilot but will be resting over the pilot shield.**

3. Place the left front log in place by setting it over the left side of the rear log (match protrusion to indentation), the hearth brick and over the left tong on the grate. Match the notch at the bottom of the branch with the tong on the grate.



Step 3

LG596

- Place the middle log over the two burners by setting the flat surface over the burner and matching the indentation located underneath the branch over the protrusion located at V-branch on the left front log placed in step #3. Rotate the right end of the log clockwise until it comes in contact with the reverse bend on the bracket located between the front and rear burner.

**Step 5**

LG598

**Step 4**

LG597

- Place the upper left log at angle over the rear and the middle logs by matching the indentation on the bottom of the log with protrusion on the rear log. Set the pointed end of the log over the flat surface of the middle log. When this log is in place the pointed end will come in contact with the back of the pilot log placed in step #2.

**Step 6**

LG599

- Place the right upper log over the pilot log and the hearth brick by matching the indentation on the bottom of the log with the protrusion on the pilot log.

**Step 7**

LG600

- Place the upper right rear log over the rear log and the right upper log by matching the indentations located at the bottom with the protrusions on the rear log and the right upper log.

8. Replace glass in reverse order of instructions on Page 45.
9. Slide the rings of the screen provided inside the unit above the grate over the rod. Make sure the screen handles are toward the center.
10. Hook the rod screen assemblies over the three hooks located behind the face in front of the glass. **NOTE:** The opening of the hooks are toward the back.

WARNING

Turn off gas before servicing fireplace. It is recommended that a qualified service technician perform these check-ups at the beginning of each heating season

BURNER, PILOT AND CONTROL COMPARTMENT

Keep the control compartment, logs, and burner areas surrounding the logs clean by vacuuming or brushing at least twice a year. Make sure the burner porting, pilot air opening and burner air opening are free of obstructions at all times.

PILOT FLAME

The flames from the pilot should be visually checked as soon as the heater is installed and periodically during normal operation. **The pilot flame must always be present when the fireplace is in operation.** *Figure 63.* The pilot flame has three distinct flames, one engulfing the thermopile, one engulfing the thermocouple, and the other reaching to the main burner.

BURNER

Inspect area around the injector. Remove any lint or foreign material with a brush or vacuum.

BURNER FLAME

The flames from the burner should be visually checked as soon as the heater is installed and periodically during normal operation. In normal operation, at full rate, and after operating for about 15 to 30 minutes, the flame should be yellow and slightly taller than the rear log. *Figure 64*

If the flame is blue and only in the center, turn off unit and let cool. After unit is cool, remove logs and check to make sure the back holes in the burner are not covered with rock wool. If the back holes are clear, add more rock wool to the center of the burner. Replace logs.

NOTE: The type of installation, vent system configuration, and wind effects may cause the flame patterns to vary.

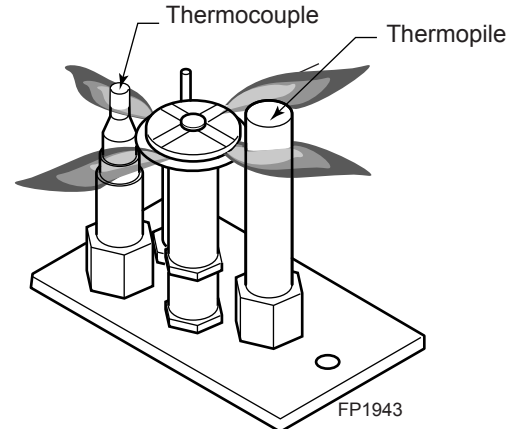

**Figure 63 -
Pilot Flame**

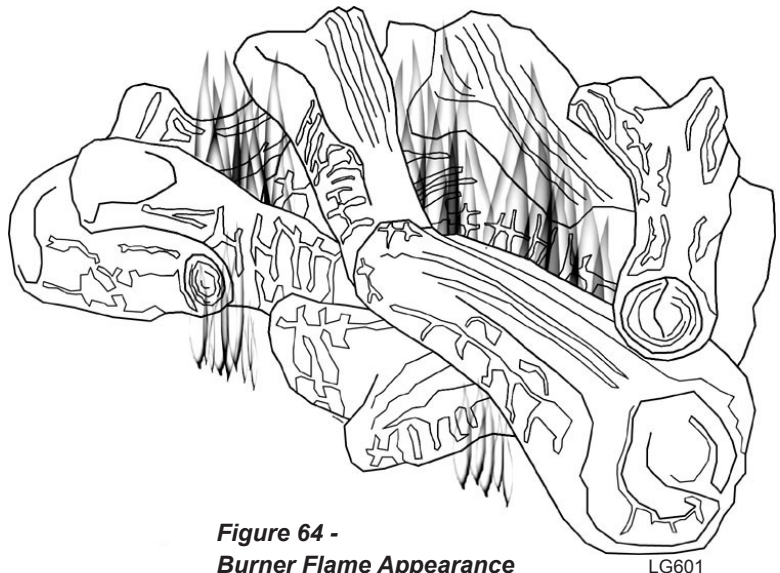

**Figure 64 -
Burner Flame Appearance**

VENT SYSTEM

The fireplace and venting system should be inspected before initial use and at least annually by a qualified field service person. Inspect the external vent cap on a regular basis to make sure that no debris is interfering with the airflow. Inspect entire venting system to ensure proper function.

GLASS DOOR

Thoroughly clean the inside of the glass door after using the fireplace for ten hours. Periodically clean the glass door as necessary.

When cleaning the glass, remember:

- **Do not remove the glass when hot.** Allow glass to cool before removal.
- NEVER use abrasive materials.
- Keep children and pets a safe distance away.
- Never operate the fireplace without the glass door properly secured.
- Never operate the fireplace if the glass is broken.
- Replace any glass that is chipped, cracked, or broken. Replacement glass door assemblies **MUST** be supplied by the fireplace manufacturer – **No substitute materials may be used.**
- Handle glass door with care to avoid striking or scratching it on hard objects.

To clean glass door, follow “Glass Removal” procedure outlined in the *Final Installation* section. Film deposit on the inside of the glass should be cleaned off using a nontoxic, non-corrosive, non-abrasive, mild-cleaning solution. Simply apply an adequate amount to the glass and wipe off with a damp cloth. After all maintenance has been completed, re-install glass door.

LOGS

Leave logs installed in the fireplace for cleaning. Vacuum surface of the logs with a brush attachment. If logs must be removed for cleaning, handle carefully by holding gently at each end. Gloves are recommended to prevent skin irritation from ceramic fibers. If skin becomes irritated, wash gently with soap and water. Vacuum surface of logs with brush attachment or brush logs with a soft bristle brush (i.e. clean, dry paintbrush). To place logs back in the fireplace, see “Log Placement” found in the *Final Installation* section.

NOTE: Do not use fluids to clean ceramic fiber logs.

ROCK WOOL

Replace or add rock wool as required following installation instructions in the *Final Installation* section of this manual.

STANDING PILOT IGNITION

SYMPTOM	POSSIBLE CAUSE	ACTION
1. Spark ignitor will not light pilot after repeated triggering of piezo.	A. Wire disconnected.	A. Open door and check to make sure wire is connected to ignitor.
	B. Defective ignitor.	B. Check for spark at electrode and pilot. If no spark and electrode wire is properly connected, replace pilot assembly.
	C. No gas or low gas pressure.	C. Check remote/manual shut off valve from fireplace. Low pressure can be caused by bent lines, restricted lines, low pressure line pressure. Consult with plumber or gas supplier.
	D. No Propane/LPG in tank	D. Check Propane/LPG tank. Refill tank.
2. Pilot will not stay lit after carefully following lighting instructions.	A. Defective thermocouple	A. Check that thermocouple flame impinges on thermocouple. Clean and/or adjust pilot for maximum flame impingement. Ensure that the thermocouple connection at the gas valve is fully inserted and tight. Disconnect the thermocouple from the valve, place one millivolt lead wire on the tip of the thermocouple and the other meter lead wire on the thermocouple copper lead. Start the pilot and hold the valve knob in. If the millivolt reading is less than 15 mV, replace pilot assembly.
	B. Defective valve	B. If thermocouple is producing more than 15 mV, replace faulty valve.
3. Pilot burning, valve knob turned to "ON," switch is turned to "ON" or "RS," but burner will not ignite.	A. Defective switch, wall switch, remote control or wire	A. Check switch and wire for proper connection. Place jumper wires across terminals of switch. If burner comes on, replace defective switch. If the switch is OK, repeat the same procedure on remote control. If burner comes on, replace remote control. Place jumper wire across wire at gas valves (terminals marked TH and TP/TH). If burner comes on, wires are faulty or connections are bad. Replace wire.
	B. Pilot flame too small	B. If pilot flame is not close enough to the thermopile, adjust pilot flame.
	C. Defective or malfunctioning thermopile	C. Check thermopile wire connections to make sure all are tight and that the thermopile is fully inserted into pilot assembly. Check thermopile with a millivolt meter. Connect leads to TP and TP/TH terminals on the control valve. If meter reading is below 325 mV, replace pilot assembly.
	D. Defective valve	D. Turn valve knob to "On" and switch to "ON." Take a reading at the thermopile leads (TP & TP/TH) on the valve. If the meter reads greater than 175 mV and the burner does not light, replace defective valve.

STANDING PILOT IGNITION

SYMPTOM	POSSIBLE CAUSE	ACTION
4. Frequent pilot outage problem.	A. Pilot flame may be too high or too low, causing pilot safety to drop out	A. Clean and adjust the pilot flame for maximum flame impingement on thermocouple.
5. The pilot and main burner extinguish while in operation	A. Inner vent pipe leaking exhaust gases back into system B. Horizontal vent improperly pitched C. Improper vent cap installation	A. Check for flue product leak. Replace defective pipe section. B. Check horizontal-venting piping is running upward 1/4" per foot. Do not run the pipe level or downward. C. Check for proper installation and freedom from debris or blockage.
6. Glass Soots	A. Flame impingement on logs	A. Install log set per the instructions Inspect the injector and air intake area. Make sure this area does not have any blockage from debris and clean. Check gas supply.
7. Flame burn blue and lifts off burner (ghosting)	A. Insufficient oxygen being supplied	A. Ensure that the vent cap is installed properly and free of debris. Ensure that the vent system joints are tight and have no leaks. Ensure that no debris has been blocking the inner air intake at the bottom back of the combustion chamber. Ensure that the glass is properly secure and latch.

SIGNATURE COMMAND SYSTEM

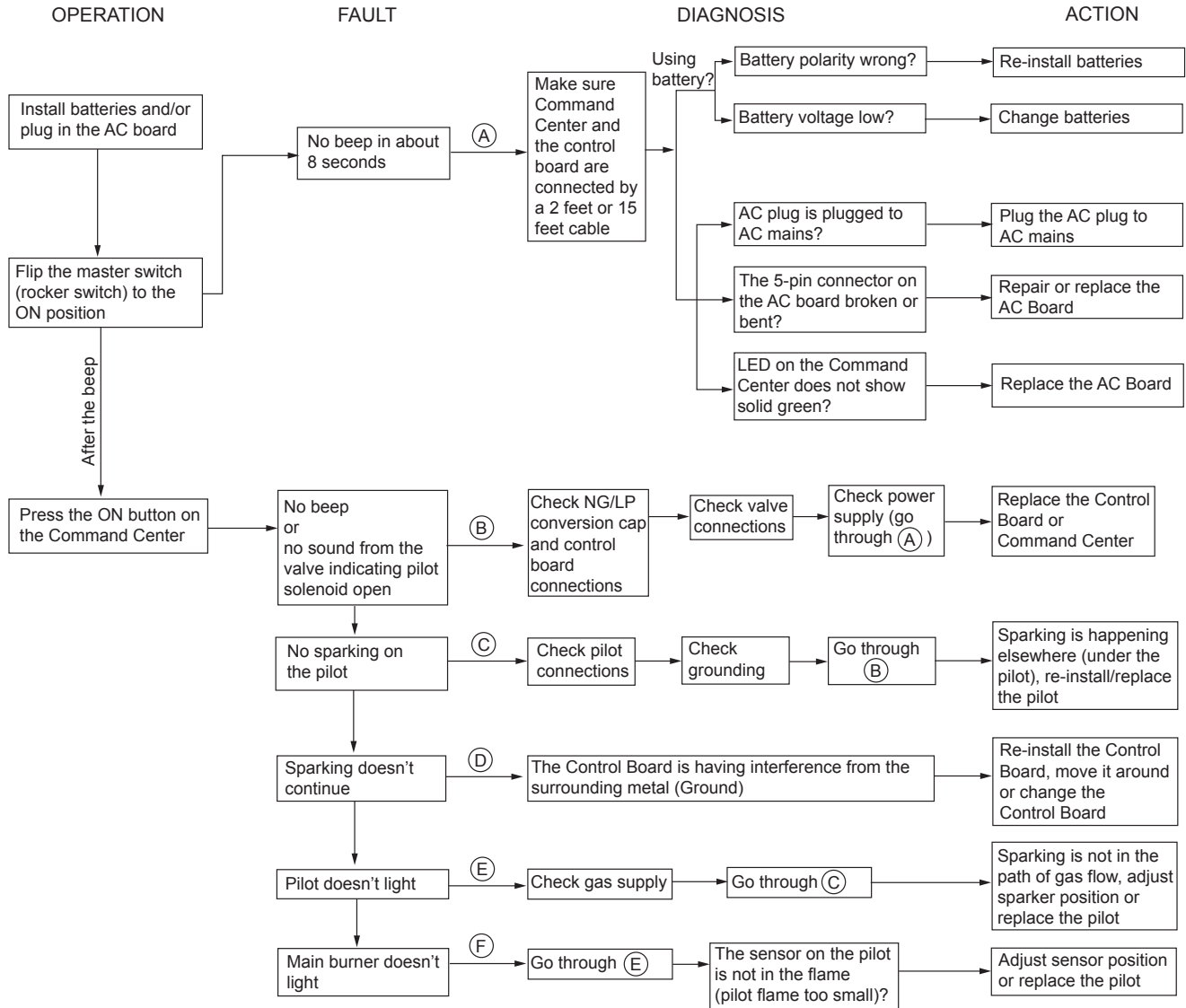

FIREBOX COMPONENTS AND ACCESSORIES

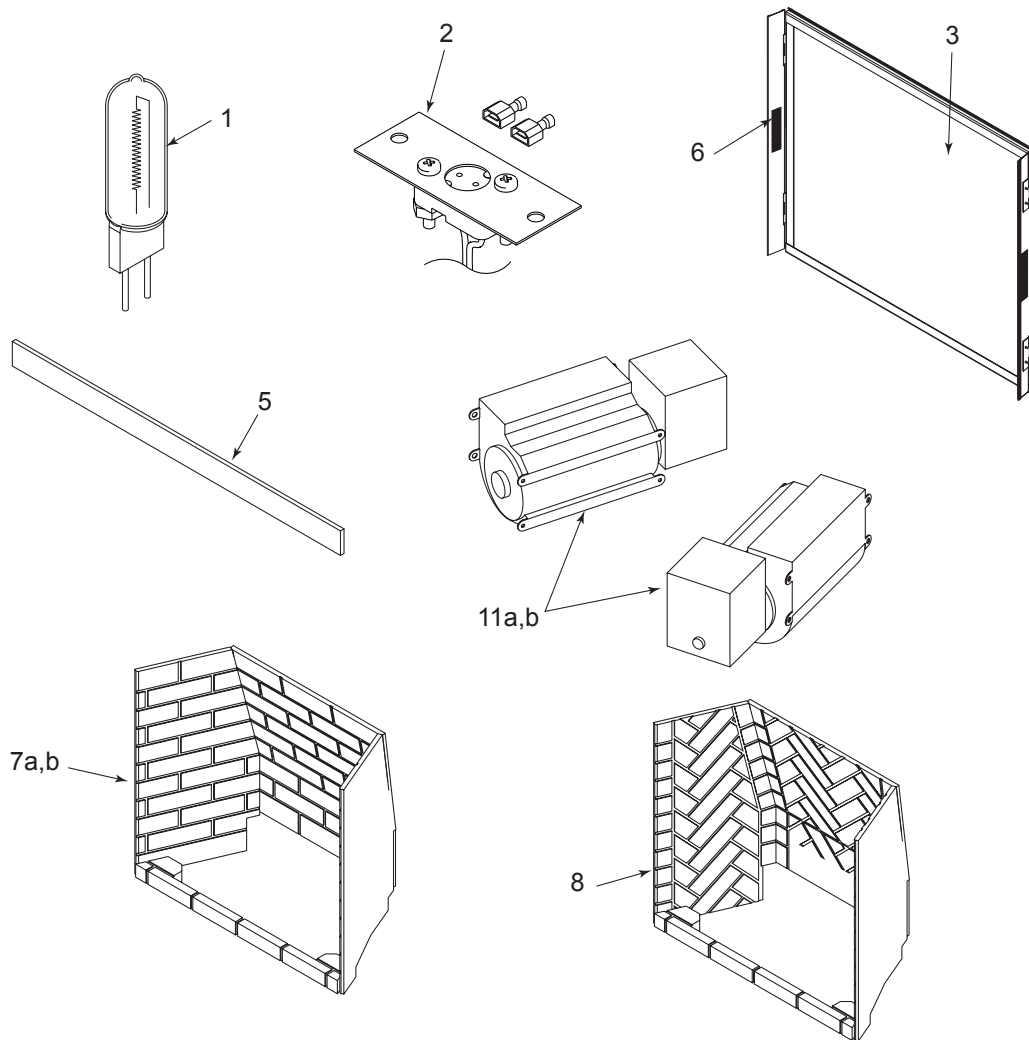

Item	Description	Qty.	KHLDV400	KHLDV500
1.	Bulb	2	73D0020	73D0020
2.	Bulb Socket	2	73D4521K	73D4521K
3.	Glass Frame Assembly	1	73D1015K	73D0159K
4.	Junction Box Assembly (not shown)	1	26D2128K	26D2128K
5.	Light Lens	1	73D0022	73D0022
6.	Panel, Access, Door	2	73D0029K	73D0029K
7a.	Cottage Clay Firebrick Set	1	FBKHLDV400CC	FBKHLDV500CC
7b.	Cottage Red Firebrick Set	1	FBKHLDV400CR	FBKHLDV500CR
8.	Vintage Brown Herringbone Firebrick Set	1	FBKHLDV400VB	FBKHLDV500VB
Accessories / Field Installed Options				
9.	Right Access Panel, w/Louvers (used with blower)	1	73D4511K	73D4511K
10.	Left Access Panel, w/Louvers (used with blower)	1	73D4512K	73D4512K
11a.	T-Stat Blower with Speed Control (Millivolt system)	1	BLOTKHLTD	BLOTKHLTD
11b.	Blower Kit (Signature Command System)	1	BLOTKHLSC	BLOTKHLSC

STANDING PILOT — MILLIVOLT CONTROL

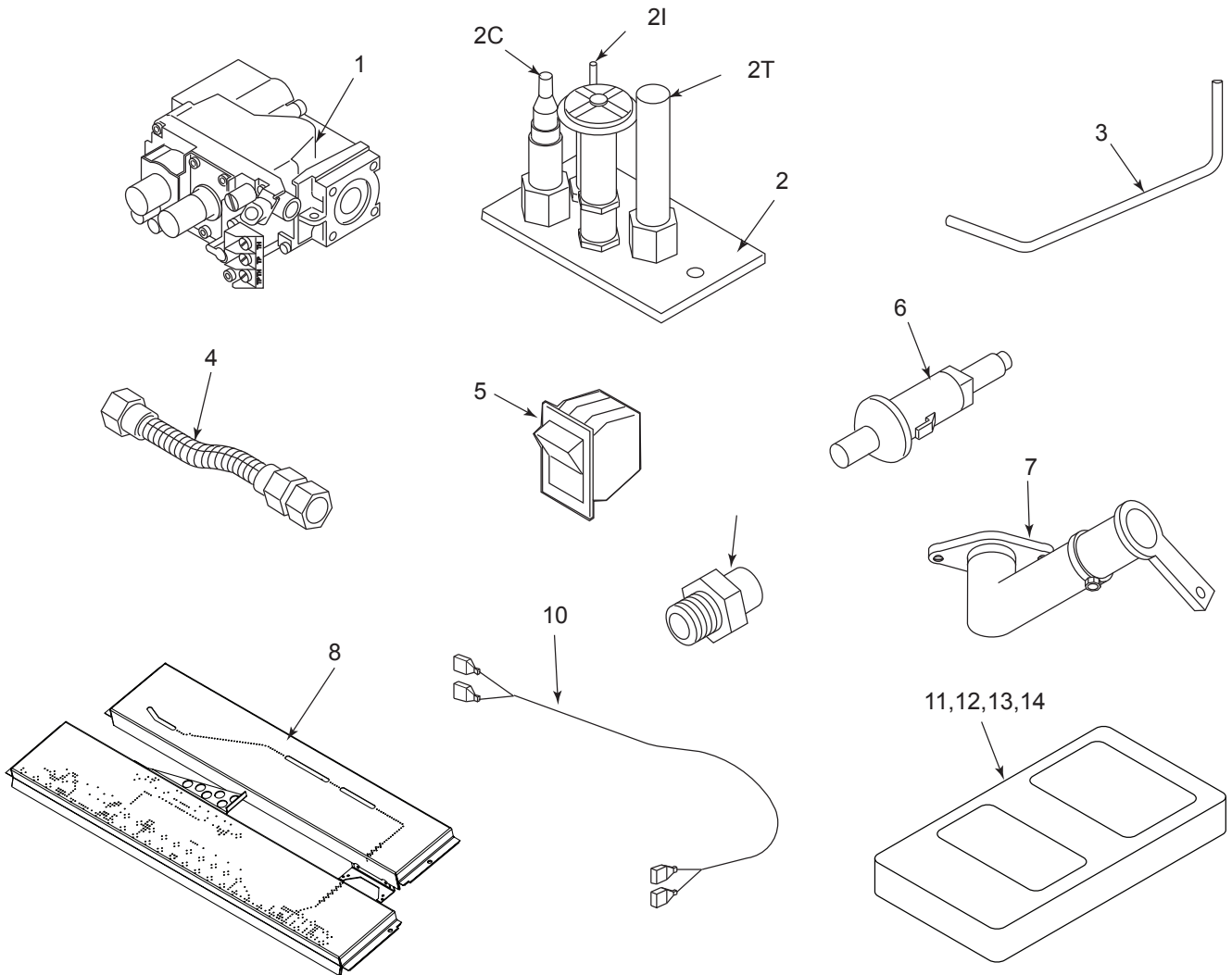

STANDING PILOT – MILLIVOLT CONTROL

Item	Description	Qty.	KHLDV400NV	KHLDV400PV	KHLDV500NV	KHLDV500PV
1.	Gas Valve Assembly	1	37D0117	37D0118	37D0117	37D0118
2.	Pilot Assembly	1	20H2048	20H2049	20H2048	20H2049
2C.	Replacement Thermocouple	1	37D1067	37D1067	37D1067	37D1067
2I.	Replacement Igniter w/wire	1	37D1069	37D1069	37D1069	37D1069
2T.	Replacement Thermopile	1	37D1068	37D1068	37D1068	37D1068
3.	Tube, Rear, Venturi	1	73D0050	74D0050	54D0564	54D0564
3.	Tube, Front, Venturi	1	73D0562	73D0562	43D0185	43D1085
3.	Tube, Rear, Through-wall	1	73D0145	73D0145	73D0145	73D0145
3.	Tube, Front, Through-wall	1	73D0146	73D0146	73D0146	73D0146
4.	Flexhose w/Shutoff Valve	1	69D0030	69D0030	69D0030	69D0030
5.	Rocker Switch	1	41D0048	41D0048	41D0048	41D0048
6.	Piezo Igniter	1	14D0503	14D0503	14D0503	14D0503
7.	Rear Injector	1	58D0102	58D0052	57D0679	57D0680
7.	Front Injector	1	57D0612	58D0056	56D3059	62D3005
8.	Rear Burner Assembly	1	73D3270	73D3270	73D2368	73D3268
8.	Front Burner Assembly	1	73D3269	73D3269	73D3267	73D3267
9.	Venturi	1	45D0600	45D0600	45D0600	45D0600
10.	Wire Assembly	1	44D0500	44D0500	44D0500	44D0500
10.	Wire Assembly	1	44D0501	44D0501	44D0501	44D0501
Accessories						
11.	On/Off Remote Control	1	RCB / RCBE / RCMT / WMTD			
12.	Thermostatic Remote Control	1	RCST/RCT / RCSTE / RCSTEB / RCSITE / WWTD			
13.	Wall Switch Kit	1	MVWS			
14.	Wall Thermostat Kit	1	WT			
15.	Forged Andiron 13"	1	FA113			
15.	Cast Iron 12 ¹ / ₂ "	1	CAI121/2			

Fuel Conversion Kits - Millivolt Control

Natural Gas to LP

KHLDV400 Kit #KHL400CKP

KHLDV500 Kit #KHL500CKP

LP to Natural Gas

KHLDV400 Kit #KHL400CKN

KHLDV500 Kit #KHL500CKN

SIGNATURE COMMAND SYSTEM

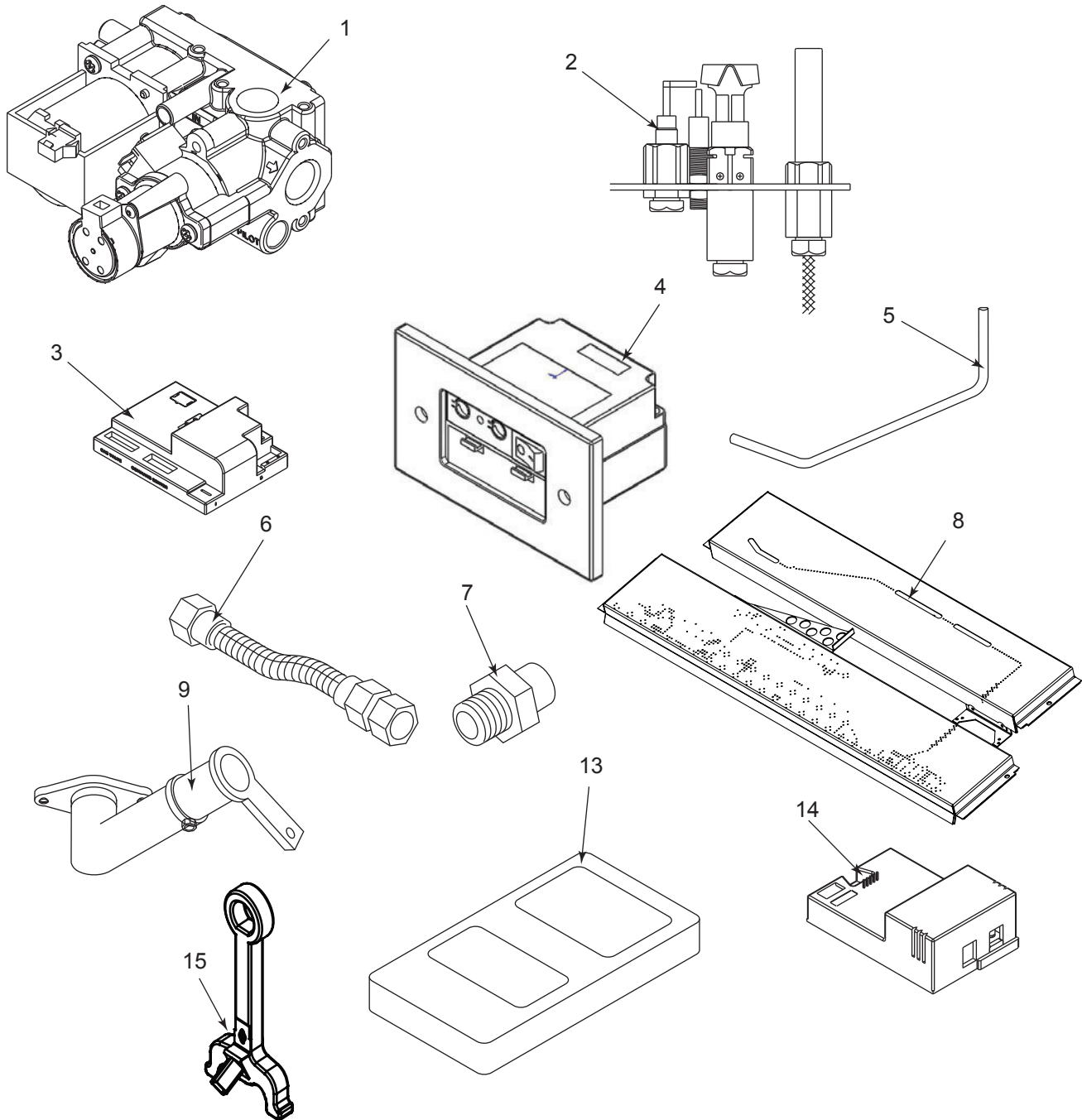

SIGNATURE COMMAND SYSTEM

Item	Description	Qty.	KHLDV400NTSC	KHLDV400PTSC	KHLDV500NTSC	KHLDV500PTSC
1.	Gas Valve Assembly	1	80D0001	80D0002	80D0001	80D0002
2.	Pilot Assembly	1	80D0039	80D0040	80D0039	80D0040
3.	Control Box	1	80D0037	80D0038	80D0037	80D0038
4.	Command Center	1	80D0005	80D0005	80D0005	80D0005
5.	Tube, Rear, Venturi	1	73D349K	73D3549K	54D0564	54D0564
5.	Tube, Front, Venturi	1	73D0562K	73D0562K	43D0185	43D1085
5.	Rear Tube, Tee to Solenoid	1	73D3529K	73D3529K	73D3529K	73D3529K
5.	Rear Tube, Solenoid to Venturi	1	73D3528K	73D3528K	73D3528K	73D3528K
5.	Tube, Front, Through-wall	1	73D0146K	73D0146K	73D0146	73D0146
6.	Flexhose w/Shutoff Valve	1	69D0030	69D0030	69D0030	69D0030
7.	Rear Injector	1	38D0102	38D0102	57D0679	57D0680
7.	Front Injector	1	57D0612	57D0612	56D3059	62D3005
8.	Rear Burner Assembly	1	73D3270	73D3270	73D3268	73D3268
8.	Front Burner Assembly	1	73D3269	73D3269	73D3267	73D3267
9.	Venturi	1	45D0600	45D0600	45D0600	45D0600
10.	Wire Valve/Control (not shown)	1	80D0010	80D0010	80D0010	80D0010
11.	Wire AC Module (not shown)	1	80D0009	80D0009	80D0009	80D0009
12.	Wire Command Ctr. (not shown)	1	80D0008	80D0008	80D0008	80D0008
13.	Remote Transmitter (full function)	1	RFSC	RFSC	RFSC	RFSC
14.	AC Module	1	SCSACM	SCSACM	SCSACM	SCSACM
15.	Solenoid (not shown)	1	73D3007	73D3007	73D3007	73D3007
Accessories						
16.	Forged Andiron 13"	1	FA113	FA113	FA113	FA113
17.	Cast Iron 12 ¹ / ₂ "	1	CAI121/2	CAI121/2	CAI121/2	CAI121/2

Fuel Conversion Kits - Signature Command System

Natural Gas to LP

- KHLDV400 Kit #KHL400CKPS
- KHLDV500 Kit #KHL500CKPS

LP to Natural Gas

- KHLDV400 Kit #KHL400CKNS
- KHLDV500 Kit #KHL500CKNS

VENT COMPONENTS

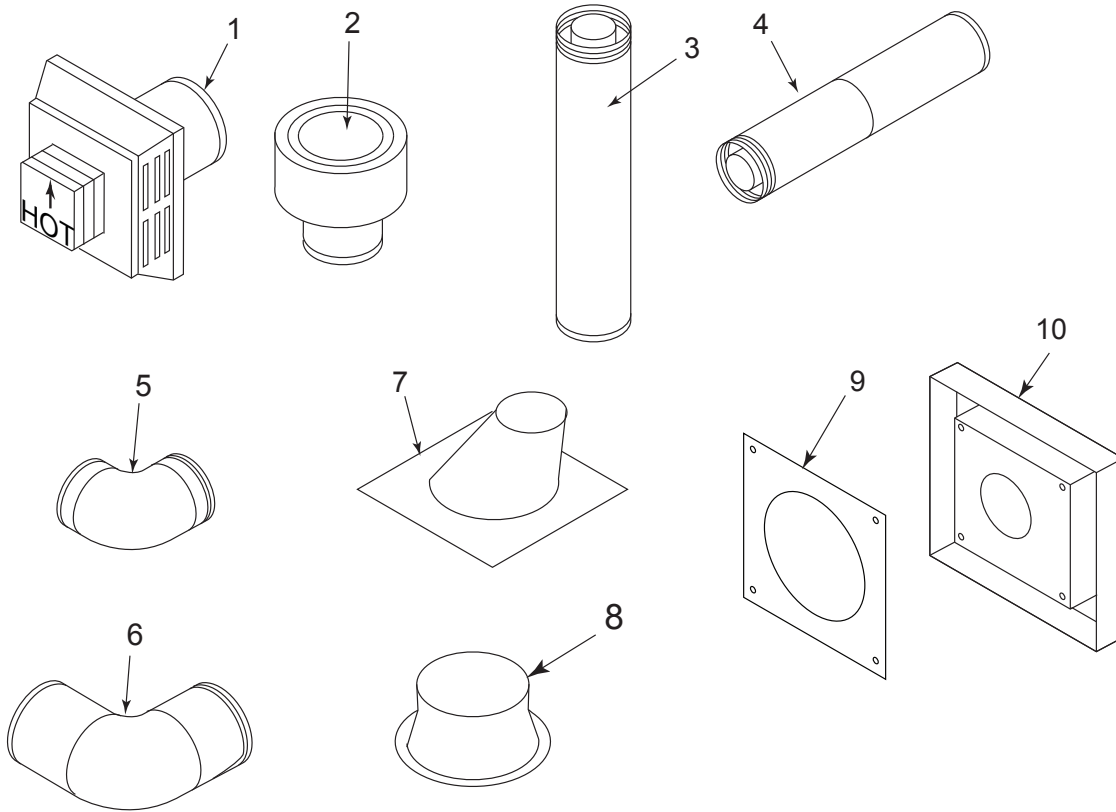

VENT COMPONENTS FOR 5"x 8"

Item	Qty./ Box	Description	Current Simpson DuraVent or MHSC Part no.	Old Simpson DuraVent or MHSC Part no.	Selkirk Part no.
1	1	Horizontal High Wind Termination Cap	58DVA-HC	1285	5DT-HC
1	1	Horizontal Termination Cap w/Built-In Vinyl Siding Standoff, Heat Deflector, Firestop and Adjustable Pipe 7" to 11"		BHR8TK	
1	1	Horizontal Termination Cap Built-In Vinyl Siding Standoff, Heat Deflector, Firestop, 90° Elbow and Adjustable Pipe 11" to 14" 24" Section of Pipe		KHLBHS8TK	
2	1	Vertical Termination	*see below	*see below	5DT-VC
2	1	Extended Vertical Termination	58DVA-VCE	1283	--
2	1	High Wind Vertical Termination	58DVA-VCH	1291	--
3	4	6" Pipe Length	58DVA-06	1208	5DT-06
3	4	9" Pipe Length	58DVA-09	1207	5DT-09
3	4	12" Pipe Length	58DVA-12	1206	5DT-12
3	4	24" Pipe Length	58DVA-24	1204	5DT-24
3	4	36" Pipe Length	58DVA-36	1203	5DT-36
3	4	48" Pipe Length	58DVA-48	1202	5DT-48
4	4	8½" Pipe Extension	58DVA-08A	--	5DT-AJ
4	4	16" Pipe Extension	58DVA-16A	--	--
5	4	45° Elbow	58DVA-E45	1245	5DT-EL45
5	4	45° Swivel Elbow	--	--	5DT-EL45
6	4	90° Elbow	58DVA-E90	1290	5DT-EL90S
6	4	90° Swivel Elbow	--	1290G	5DT-EL90S
7	6	Flashing, 0/12 to 6/12 Roof Pitch	58DVA-F6	1243	5DT-AF6
7		Steep Roof Flashing	58DVA-F12	1243S	--
8	6	Storm Collar	58DVA-SC	1253	5DT-SC
9	4	Firestop	58DVA-FS	1263	5DT-FS
9		3" Firestop	FS38	FS38	--
10	1	Vinyl Siding Standoff	58DVA-VSS	1250	5DT-VS
11		Attic Insulation Shield (not shown)	58DVA-IS	--	--

***SIMPSON DURAVENT 58DVA-VC/1280 VERTICAL CAP CANNOT BE USED WITH THIS FIREPLACE.**

For more information about, or instructions for, the venting components referenced above, please contact the component manufacturer:

Selkirk Corporation: www.selkirkcorp.com or 800-992-8368

Simpson DuraVent: www.duraVent.com or 800-835-4429

LOGS

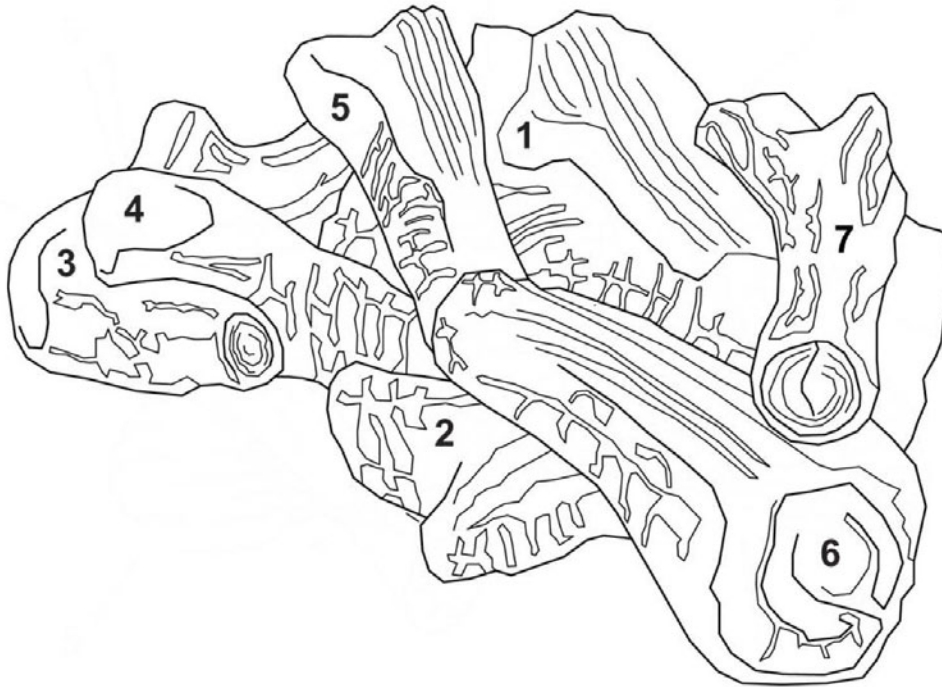

Item	Description	Qty.	KHLDV400	KHLDV500
1.	Log #1	1	73D0532	73D0134
2.	Log #2	1	73D0533	73D0135
3.	Log #3	1	73D0534	73D0136
4.	Log #4	1	73D0535	73D0137
5.	Log #5	1	73D0536	73D0138
6.	Log #6	1	73D0537	73D0139
7.	Log #7	1	73D0538	73D0140

Requirements for the Commonwealth of Massachusetts

This product must be installed by a licensed plumber or gas fitter when installed within the Commonwealth of Massachusetts.

Note Regarding Vented Products

Flex line installation must not exceed 36 inches and must have a T shutoff valve.

Any residence with a direct vent product must have a CO detector installed in the residence.

Installation of the fireplace or vented gas log in the State of Massachusetts requires the damper to be permanently removed or welded in the fully open position.

In addition, neither a naturally vented gas log nor a vent-free product may be installed in a bedroom or bathroom in the State of Massachusetts.

All gas fitting and installation of this heater shall only be done by a licensed gas fitter or licensed plumber.

For all side wall horizontally vented gas fueled equipment installed in every dwelling, building or structure used in whole or in part for residential purposes, including those owned or operated by the Commonwealth and where the side wall exhaust vent termination is less than seven (7) feet above finished grade in the area of the venting, including but not limited to decks and porches, the following requirements shall be satisfied:

Installation of Carbon Monoxide Detectors

At the time of installation of the side wall horizontal vented gas fueled equipment, the installing plumber or gas fitter shall observe that a hard wired carbon monoxide detector with an alarm is installed on each additional level of the dwelling, building or structure served by the side wall horizontal vented gas fueled equipment. It shall be the responsibility of the property owner to secure the services of qualified licensed professionals for the installation of hard wired carbon monoxide detectors.

In the event that the side wall horizontally vented gas fueled equipment is installed in a crawl space or an attic, the hard wired carbon monoxide detector with alarm and battery back-up may be installed on the next adjacent floor level.

In the event that the requirements of this subdivision can not be met at the time of completion of installation, the owner shall have a period of thirty (30) days to comply with the above requirements; provided, however, that during said thirty (30) day period, a battery operated carbon monoxide detector with an alarm shall be installed.

Approved Carbon Monoxide Detectors

Each carbon monoxide detector as required in accordance with the above provisions shall comply with NFPA 720 and ANSI/UL 2034 listed and IAS certified.

Signage

A metal or plastic identification plate shall be permanently mounted to the exterior of the building at a minimum height

of eight (8) feet above grade directly in line with the exhaust vent terminal for the horizontally vented gas fueled heating appliance or equipment. The sign shall read, in print size no less than one-half (1/2) inch in size, **“GAS VENT DIRECTLY BELOW, KEEP CLEAR OF ALL OBSTRUCTIONS”**.

Inspection

The state or local gas inspector of the side wall horizontally vented gas fueled equipment shall not approve the installation unless, upon inspection, the inspector observes carbon monoxide detectors and signage installed in accordance with the provisions of 248 CMR 5.08(2)(a)1 through 4.

Exemptions

The following equipment is exempt from 248 CMR 5.08(2)(a)1 through 4:

- The equipment listed in Chapter 10 entitled “Equipment Not Required To Be Vented” in the most current edition of NFPA 54 as adopted by the Board; and
- Product Approved side wall horizontally vented gas fueled equipment installed in a room or structure separate from the dwelling, building or structure used in whole or in part for residential purposes.

MANUFACTURER REQUIREMENTS

Gas Equipment Venting System Provided

When the manufacturer of Product Approved side wall horizontally vented gas equipment provides a venting system design or venting system components with the equipment, the instructions provided by the manufacturer for installation of the equipment and the venting system shall include:

- Detailed instructions for the installation of the venting system design or the venting system components; and
- A complete parts list for the venting system design or venting system.

Gas Equipment Venting System NOT Provided

When the manufacturer of a Product Approved side wall horizontally vented gas fueled equipment does not provide the parts for venting the flue gases, but identifies “special venting systems”, the following requirements shall be satisfied by the manufacturer:

- The referenced “special venting system” instructions shall be included with the appliance or equipment installation instructions; and
- The “special venting systems” shall be Product Approved by the Board, and the instructions for that system shall include a parts list and detailed installation instructions.

A copy of all installation instructions for all Product Approved side wall horizontally vented gas fueled equipment, all venting instructions, all parts lists for venting instructions, and/or all venting design instructions shall remain with the appliance or equipment at the completion of the installation.

LIMITED LIFETIME WARRANTY POLICY

LIFETIME WARRANTY

The following components are warranted for life to the original owner, subject to proof of purchase: Firebox, Combustion Chamber, Heat Exchanger, Grate and Stainless Steel Burners.

FIVE YEAR WARRANTY

The following components are warranted five (5) years to the original owner, subject of proof of purchase: Ceramic Fiber Logs.

BASIC WARRANTY

MHSC warrants the components and materials in your gas appliance to be free from manufacturing and material defects for a period of two years from date of installation. After installation, if any of the components manufactured by MHSC in the appliance are found to be defective in materials or workmanship, MHSC will, at its option, replace or repair the defective components at no charge to the original owner. MHSC will also pay for reasonable labor costs incurred in replacing or repairing such components for a period of two years from date of installation. Any products presented for warranty repair must be accompanied by a dated proof of purchase.

This Limited Lifetime Warranty will be void if the appliance is not installed by a qualified installer in accordance with the installation instructions. The Limited Lifetime Warranty will also be void if the appliance is not operated and maintained according to the operating instructions supplied with the appliance, and does not extend to (1) firebox/burner assembly damage by accident, neglect, misuse, abuse, alterations, negligence of others, including the installation thereof by unqualified installers, (2) the costs of removal, reinstallation or transportation of defective parts on the appliance, or (3) incidental or consequential damage. All service work must be performed by an authorized service representative.

This warranty is expressly in lieu of other warranties, express or implied, including the warranty of merchantability of fitness for purpose and of all other obligations or liabilities. MHSC does not assume for it any other obligations or liabilities in connection with sale or use of the appliance. It states that do not allow limitations on how long an implied warranty lasts, or do not allow exclusion of indirect damage, those limitations of exclusions may not apply to you. You may also have additional rights not covered in the Limited Lifetime Warranty.

MHSC reserves the right to investigate any and all the claims against the Limited Lifetime Warranty and decide upon method of settlement.

IF WARRANTY SERVICE IS NEEDED...

1. Contact your supplier. Make sure you have your warranty, your sales receipt and the model/serial number of your MHSC product.
2. DO NOT ATTEMPT TO DO ANY SERVICE WORK YOURSELF.

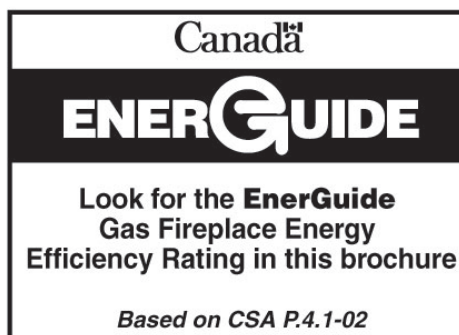

Efficiency Ratings	
Model	EnerGuide Ratings Fireplace Efficiency (%)
KHLDV400NV	69.6
KHLDV400PV	78.2
KHLDV400NSC	n/a
KHLDV400PSC	n/a
KHLDV500NV	75.2
KHLDV500PV	69.8
KHLDV500NSC	n/a
KHLDV500PSC	n/a

MHSC

149 Cleveland Drive • Paris, Kentucky 40361
www.mhsc.com