

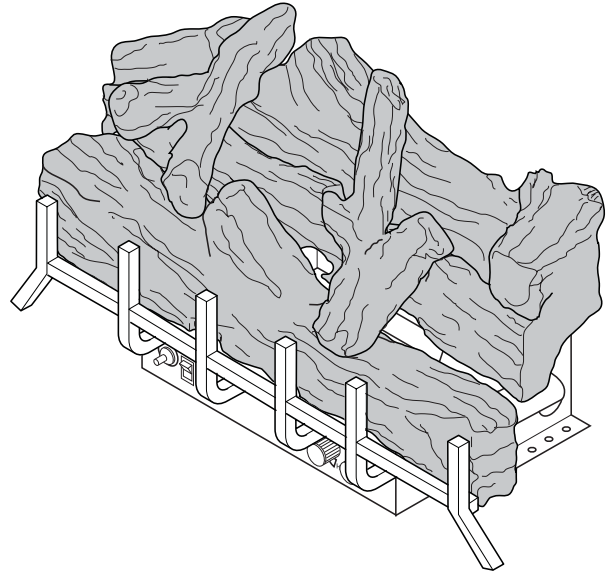

UNVENTED GAS LOG HEATER OR VENTED DECORATIVE APPLIANCE INSTALLATION AND OPERATING INSTRUCTIONS

MODELS EYF18 AND EYF24
Natural Gas or Propane/LPG
Control Type: Manual or Millivolt



This is an unvented gas-fired heater. It uses air (oxygen) from the room in which it is installed. Provisions for adequate combustion and ventilation air must be provided. *See page 7.*

WARNINGS

If the information in this manual is not followed exactly, a fire or explosion may result causing property damage, personal injury or loss of life.

- Do not store or use gasoline or other flammable vapors and liquids in the vicinity of this or any other appliance.
- **WHAT TO DO IF YOU SMELL GAS**
 - Do not try to light any appliance.
 - Do not touch any electrical switch; do not use any phone in your building.
 - Immediately call your gas supplier from a neighbor's phone. Follow the gas supplier's instructions.
 - If you cannot reach your gas supplier, call the fire department.
- Installation and service must be performed by a qualified installer, service agency or the gas supplier.

READ BEFORE INSTALLING. SAVE THESE INSTRUCTIONS

CONTENTS

Important Safety Information	3	Log Placement	21
Getting Started	5	EYF24-F.....	21
Product Features and Specifications	6	EYF18-R	22
General Installation Information	7	EYF24-R	23
Codes.....	7	Flame Appearance	24
Adequate Combustion and		Checking Burner Flame	25
Ventilation Air	7	Operating Instructions	25
Fireplace and Hearth Dimensions	9	For Your Safety Read Before Lighting	26
Placement in a Fireplace with a Restrictive		Manual Control Lighting Instructions.....	27
Barrier	10	Millivolt Control Lighting Instructions.....	28
Clearances and Height Requirements	11	Match Lighting Instructions	29
Floor Clearance	14	Cleaning and Servicing	29
Fireplace Preparation	15	Troubleshooting	30
Installing Vented Appliance	16	Illustrated Parts Breakdown	32
Connecting the Gas	17	Replacement Parts List	33
Checking Gas Pressure	18	Massachusetts Requirements	35
Electrical Wiring (Millivolt)	19	Warranty	Back Cover

IMPORTANT SAFETY INFORMATION

INSTALLER

Please leave these instructions with the appliance.

OWNER

Please retain these instructions for future reference.

IMPORTANT

Read these instructions carefully before installing or trying to operate this vent-free gas heater.

WARNING

- **Any change to this heater or its controls can be dangerous.**
- **Improper installation or use of the heater can cause serious injury or death from fire, burns, explosion or carbon monoxide poisoning.**
- **Do not allow fans to blow directly into the stove. Avoid any drafts that alter burner flame patterns.**
- **Do not use a blower insert, heat exchanger insert or other accessory, not approved for use with this heater where applicable.**

1. Due to high temperatures, the appliance should be located out of traffic and away from furniture and draperies.
2. Children and adults should be alerted to the hazard of high surface temperature and should stay away to avoid burns or clothing ignition.
3. Young children should be carefully supervised when they are in the same room with the appliance.
4. Do not place clothing or other flammable material on or near the appliance.
5. Any safety screen or guard removed for servicing an appliance, must be replaced prior to operating the heater.
6. Installation and repair should be done by a qualified service person.
7. To prevent malfunction and/or sooting, an unvented gas heater should be cleaned before use and at least annually by a professional service person. More frequent cleaning may be required due to excessive lint from carpeting, bedding materials, etc. It is imperative that control compartments, burners and circulating air passageways be kept clean.
8. For propane/LP insert, do not place propane/LP supply tank(s) inside any structure. Locate propane/LP supply tank(s) outdoors. To prevent performance problems, do not use propane/LP fuel tank of less than 100 lbs. capacity.
9. The installation must conform with local codes or, in the absence of local codes, with the **National Fuel Gas Code, ANSI Z223.1/NFPA54**.
10. This unit complies with ANSI Z21.11 Unvented Heaters and also complies with ANSI Z21.60 Decorative Vented Appliances for Solid Fuel Burning Fireplaces. State and local codes may only allow operation of this appliance in a vented configuration. Check your state or local codes. For vented operation, see *Vented Instructions* in this manual.
11. Do not install the heaters in a bathroom or bedroom.
12. Correct installation of the ceramic fiber logs, proper location of the heater, and annual cleaning are necessary to avoid potential problems with sooting. Sooting, resulting from improper installation or operation, can settle on surfaces outside the fireplace. See log placement instructions for proper installation.

Continued on page 4

CARBON MONOXIDE POISONING: Early signs of carbon monoxide poisoning are similar to the flu with headaches, dizziness and/or nausea. If you have these signs, the insert may not have been installed properly. Get fresh air at once! Have the insert inspected and serviced by a qualified service person. Some people are more affected by carbon monoxide than others. These include pregnant women, people with heart or lung disease or anemia, those under the influence of alcohol, and those at high altitudes.

Propane/LP gas and natural gas are both odorless. An odor-making agent is added to each of these gases. The odor helps you detect a gas leak. However, the odor added to these gases can fade. Gas may be present even though no odor exists.

IMPORTANT SAFETY INFORMATION

Continued from page 3

13. Avoid any drafts that alter burner flame patterns. Do not allow fans to blow directly into fireplace. Do not place a blower inside burn area of firebox. Ceiling fans may create drafts that alter burner flame patterns. Sooting and improper burning will occur.
14. **Caution:** Candles, incense, oil lamps, etc. produce combustion by-products including soot. Vent-free appliances will not filter or clean soot produced by these types of products. In addition, the smoke and/or aromatics (scents) may be reburnt in the vent-free appliance which can produce odors. It is recommended to minimize the use of candles, incense, etc. while the vent-free appliance is in operation.
15. This is an unvented gas-fired heater. It uses air (oxygen) from the room in which it is installed. Provisions for adequate combustion and ventilation air must be provided. *See page 7.*
16. Keep room area clear and free from combustible materials, gasoline and other flammable vapors and liquids.
17. Unvented gas heaters are a supplemental zone heater. They are not intended to be a primary heating appliance. Water vapor produced by an unvented heater can create moisture problems in a home when operated for extended periods of time.
18. During manufacturing, fabricating and shipping, various components of this appliance are treated with certain oils, films or bonding agents. These chemicals are not harmful but may produce annoying smoke and smells as they are burned off during the initial operation of the appliance; possibly causing headaches or eye or lung irritation. This is a normal and temporary occurrence.

The initial break-in operation should last two to three hours with the burner at the highest setting. Provide maximum ventilation by opening windows or doors to allow odors to dissipate. Any odors remaining after this initial break-in period will be slight and will disappear with continued use.
19. Input ratings are shown in BTU per hour and are for elevations up to 2,000 feet. For elevations above 2,000 feet, input ratings should be reduced 4 percent for each 1,000 feet above sea level. See the National Fuel Gas Code.
20. The heater and its individual shutoff valve must be disconnected from the gas supply piping system during any pressure testing of that system at test pressures in excess of 1/2 psig (3.5 kPa).

21. The heater must be isolated from the gas supply piping system by closing its individual manual shutoff valve during any pressure testing of the gas supply piping system at test pressures equal to or less than 1/2 psig (3.5 kPa).
22. Do not use this room heater if any part has been under water. Immediately call a qualified service technician to inspect the room heater and to replace any part of the control system and any gas control which has been under water.
23. This appliance must not be used with glass doors in the closed position. This can lead to pilot outages and severe sooting outside the fireplace.
24. Never burn solid fuels in a fireplace where a unvented room heater is installed.
25. Always have a fireplace screen in place when the appliance is in operation and, unless other provisions for combustion air are provided, the screen shall have an opening(s) for induction of combustion air.

This appliance may be installed in an aftermarket, permanently located, manufactured (mobile) home, where not prohibited by local codes.

This appliance is only for use with the type of gas indicated on the rating plate. This appliance is not convertible for use with other gases.

WARNING

Never connect unit to private (non-utility) gas wells. This gas is commonly known as wellhead gas.



We suggest that our gas hearth products be installed and serviced by professionals who are certified in the U.S. by the National Fireplace Institute® (NFI) as Gas Specialists.

**Attention Massachusetts Residents:
This product must be installed by a licensed gas fitter.**

MAKE SURE YOU HAVE RECEIVED ALL PARTS:

Check your packing list to verify that all listed parts have been received. You should have the following:

- Unvented gas log burner assembly
- Installation/operating instructions
- Ceramic Fiber or Refractory Cement Logs
- Plastic bag containing crushed volcanic rock
- Two (2) anchoring screws
- Grate

The millivolt controlled version of this heater is the only style designed to be operated with optional devices for ON/OFF functions. The following options may be used with the millivolt controlled heater. These options are not packaged with the log set.

- Hand held Remote with receiver
- Wall thermostat with 15' wire
- Wall switch with 15' wire
- Hand held Thermostat Remote with receiver

CAUTION

- **Handle the gas log burner assembly by the frame only. Do not pick the unit up by the burners or grate (not attached to frame).**
- **Gloves are recommended when handling ceramic fiber logs to prevent skin irritation from loose fibers. Logs are fragile — handle with care.**

Carefully inspect the contents for shipping damage. If any parts are missing or damaged, immediately inform the dealer from whom you purchased the appliance. **Do not attempt to install any part of the appliance unless you have all parts in good condition.**

WHAT YOU WILL NEED FOR INSTALLATION:

You must have the following items available before proceeding with installation:

- External regulator (for propane/LPG and 1/2 lb. natural gas systems only)
- Piping which complies with local codes
- Screwdriver
- Drill with 5/32 bit
- Manual shutoff valve
- Pipe sealant approved for use with propane/LPG (Resistant to sulfur compounds)
- Pipe wrench or appropriate size crescent wrench set
- Tee joint.
- Sediment trap

PRODUCT FEATURES AND SPECIFICATIONS

NATURAL GAS

Manual Pressure

Regulator Pressure Setting: 4.0" w.c.

Gas Inlet Pressure: Max. 10 1/2" w. c.
Min. 5" w.c.

Millivolt Pressure

Regulator Pressure Setting: 3.5" w.c.

Pilot Regulator: 3.5" w.c.
Gas Inlet Pressure: Max. 10 1/2" w. c.
Min. 5" w.c.

Model Number	Control	Gas Rate	
		Max BTU/Hr	Min BTU/Hr
EYF24NM	Manual	36,000	19,000
EYF24NV	Millivolt	36,000	24,000
EYF18NM	Manual	30,000	18,000
EYF18NV	Millivolt	30,000	26,000

PROPANE/LPG

Note: An external regulator is required to reduce supply pressure to a maximum of 13" w.c.

Manual Pressure

Regulator Pressure Setting: 10" w.c.

Gas Inlet Pressure: Maximum 13" w.c.
Minimum 11" w.c.

Millivolt Pressure

Regulator Pressure Setting: 10" w.c.

Gas Inlet Pressure: Maximum 13" w.c.
Minimum 11" w.c.

Model Number	Control	Gas Rate	
		Max BTU/Hr	Min BTU/Hr
EYF24PM	Manual	36,000	25,000
EYF24PV	Millivolt	36,000	29,000
EYF18PM	Manual	30,000	22,500
EYF18PV	Millivolt	30,000	24,500

IGNITION CONTROLS

Piezo ignitor allows ignition of the pilot without the use of matches or batteries.

Manual control has three (3) positions:

- OFF** - All gas to the gas logs is shut off at the valve.
- IGN** - Valve position to light/maintain a standing pilot.
- HI/LOW** - Variable position corresponding to desired flame height (heat input)

Millivolt control has four (4) positions:

- OFF** - All gas to the gas logs is shut off at the valve.
- IGN** - Valve position to light/maintain a standing pilot.
- ON** - Valve position to turn ON/OFF log set with remote switch/thermostat.
- HI/LOW** - Variable position to control flame height (heat output).

PILOT

The gas log heater is fitted with a specially designed safety pilot light (ODS assembly) which senses the amount of oxygen available in the room and shuts the gas log heater off if the oxygen level begins to drop below a satisfactory level. The pilot can only be relit when adequate fresh air is available.

THERMAL GENERATOR

The millivolt gas log pilot is fitted with a millivolt generator to provide power for remote activation.

CODES

Adhere to all local codes or, in their absence, the latest edition of THE NATIONAL FUEL GAS CODE ANSI Z223.1 or NFPA54 which can be obtained from...

American National Standards Institute, Inc.

1430 Broadway
New York, NY 10018

or

National Fire Protection Association, Inc.

Batterymarch Park
Quincy, MA 02269

ADEQUATE COMBUSTION AND VENTILATION AIR

This heater shall not be installed in a confined space or unusually tight construction unless provisions are provided for adequate combustion and ventilation air.

The National Fuel Gas Code, (ANSI Z223.1), defines a confined space as a space whose volume is less than 50 cubic feet per 1,000 BTU per hour (4.8 m³ per kw) of the aggregate input rating of all appliances installed in that space. An unconfined space is defined as a space whose volume is not less than 50 cubic feet per 1,000 BTU per hour (4.8 m³ per kw) of the aggregate input rating of all appliances installed in that space. Rooms communicating directly with the space in which the appliances are installed, through openings not furnished with doors, are considered a part of the unconfined space.

UNUSUALLY TIGHT CONSTRUCTION IS DEFINED AS CONSTRUCTION WHERE...

- a) walls and ceilings exposed to the outside atmosphere have a continuous water vapor retarder with a rating of 1 perm (6 x 10¹¹ kg per-pa-sec-m²) or less with openings gasketed or sealed, and
- b) weather striping has been added on openable windows and doors, and
- c) caulking or sealant are applied to areas such as joints around windows and door frames; between sole plates and doors; between wall-ceiling joints; between wall panels; at penetrations for plumbing, electrical, and gas lines; and at other openings.

GENERAL INSTALLATION INFORMATION

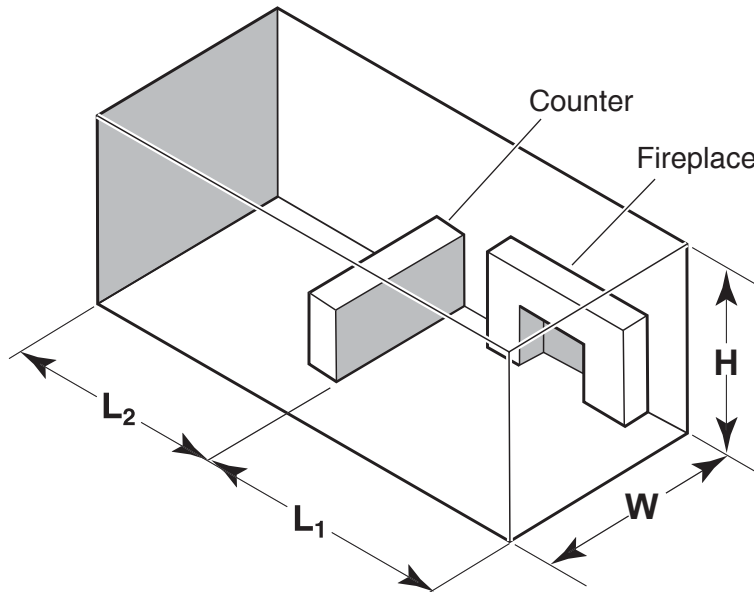

Figure 1 - Example of a Large Room with 1/2 Wall Divider

The following formula can be used to determine the maximum heater rating per the definition of unconfined space:

$$\frac{\text{BTU/Hr} = (L_1 + L_2) \text{ Ft} \times (W) \text{ Ft} \times (H) \text{ Ft}}{50} \times 1000$$

Consider two connecting rooms with an open area between, with the following dimensions:

$$L_1 = 15\frac{1}{2} \text{ Ft.}, L_2 = 12 \text{ Ft.}, W = 12 \text{ Ft.}, H = 8 \text{ Ft.}$$

$$\frac{\text{BTU/Hr} = (15\frac{1}{2} + 12) \times (12) \times (8)}{50} \times 1000 = 52800 \text{ BTU/Hr}$$

If there were a door between the two rooms the calculation would be based only on the room with the heater.

$$\frac{\text{BTU/Hr} = (15\frac{1}{2}) \times (12) \times (8)}{50} \times 1000 = 29760 \text{ BTU/Hr}$$

WARNING If the area in which the heater may be operated is smaller than that defined as an unconfined space or if the building is of unusually tight construction, provide adequate combustion and ventilation air by one of the methods described in the National Fuel Gas Code, ANSI Z223.1, Section 5.3 or applicable local codes.

FIREPLACE AND HEARTH DIMENSIONS

WARNING

This appliance has been specifically tested and design certified for installation only in a solid-fuel burning fireplace including factory-built UL127 fireplaces and masonry fireplaces, or in a listed ventless firebox (see below).

Exception: DO NOT install this appliance in a factory-built fireplace that includes instructions stating that it has not been tested or should not be used with unvented gas logs.

Use manufacturer's installation and clearance requirements as defined in their manual.

The EYF Series unvented room heater is approved for installation into the following unvented fireplaces:

GCUF(32,36,42) and VFR(32,36,42) Series Fireboxes

The EYF Series unvented room heater may also be installed into a Ventless Firebox Enclosure for Gas Fired Decorative Type Unvented Room Heaters per ANSI Z21.91b.2004, as long as firebox hearth dimensions meet the minimum hearth dimensions shown below.

Model	A	B	C	D
EYF18	25"	13"	17 ¹ / ₂ "	17"
EYF24 w/EYF24-(R,F)	29"	13"	19 ¹ / ₂ "	17"
EYF24 w/EYF30-R	33"	13"	25 ¹ / ₄ "	17"

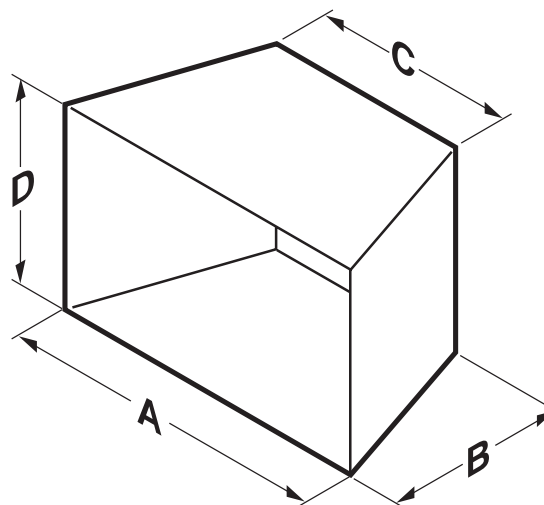

Figure 2 - Hearth Minimum Dimension for Solid Fuel Burning Fireplaces and UL127 Factory Built Fireplaces

PLACEMENT IN A FIREPLACE WITH A RESTRICTIVE BARRIER

IMPORTANT INFORMATION FOR THE INSTALLATION OF THIS GAS LOG SET

The following are guidelines for placing a gas log set in a fireplace that has a restrictive barrier along the bottom front opening of the fireplace. Some examples of barriers are glass/screen door frames and sunken/recessed fireplaces.

Height of Restriction (X)	Minimum Depth of Fireplace/Firebox
No restriction	13"
0 to 1.5"	16"
Greater than 1 1/2" to 3"	16"
Greater than 3"	Any barrier greater than three inches (3") placed in front of the gas log set is not recommended by the manufacturer.

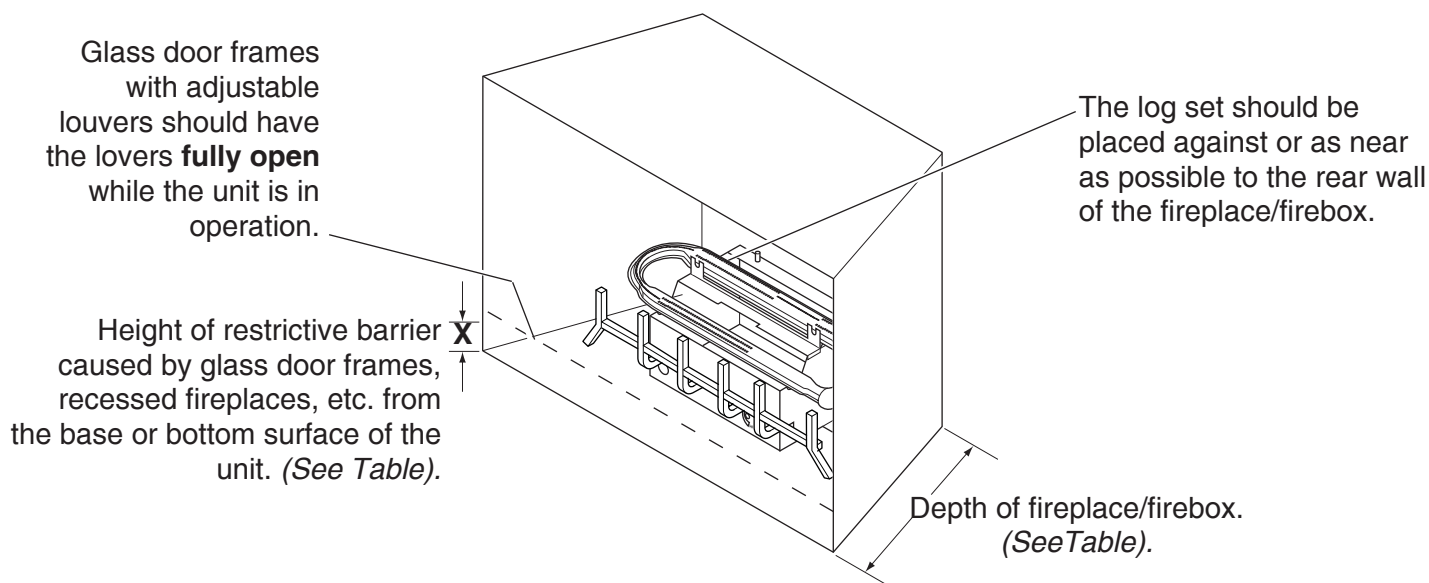

Figure 3 - Reference Drawing of a Natural Flame Log Set in an Enclosure

WARNING

Barriers such as the bottom of a glass door frame placed in front of a gas log set can change the air flow characteristics of the fireplace which in turn can cause the unit to overheat and malfunction.

NOTE: Non combustible material such as refractory brick may be used to line the floor of the fireplace in order to raise the height of the gas log set in relation to a restrictive barrier. If the unit is raised, the minimum height dimension listed in the homeowner's manual must not be exceeded.

NOTE: If the log set is equipped with a remote receiver, a restrictive barrier may reduce the battery life by increasing the ambient temperature inside the fireplace. Placement of the receiver outside of the fireplace will extend the battery life.

CLEARANCES AND HEIGHT REQUIREMENTS

WARNING

The dimensions shown in *Figures 4 through 10* and defined in the fireplace manufacturer's instructions are minimum clearances to maintain when installing this heater. Left and right clearances are determined when facing the front of the heater. When heater is installed into a ventless firebox, minimum clearances, as specified by the ventless firebox manufacturer, must be met.

Follow these instructions carefully to ensure safe installation. Failure to follow instructions exactly can create a fire hazard.

Sidewall and ceiling clearances: The *sides* of the fireplace opening must be *at least 16"* from any combustible wall. The *ceiling* must be *at least 42"* from the top of the fireplace opening.

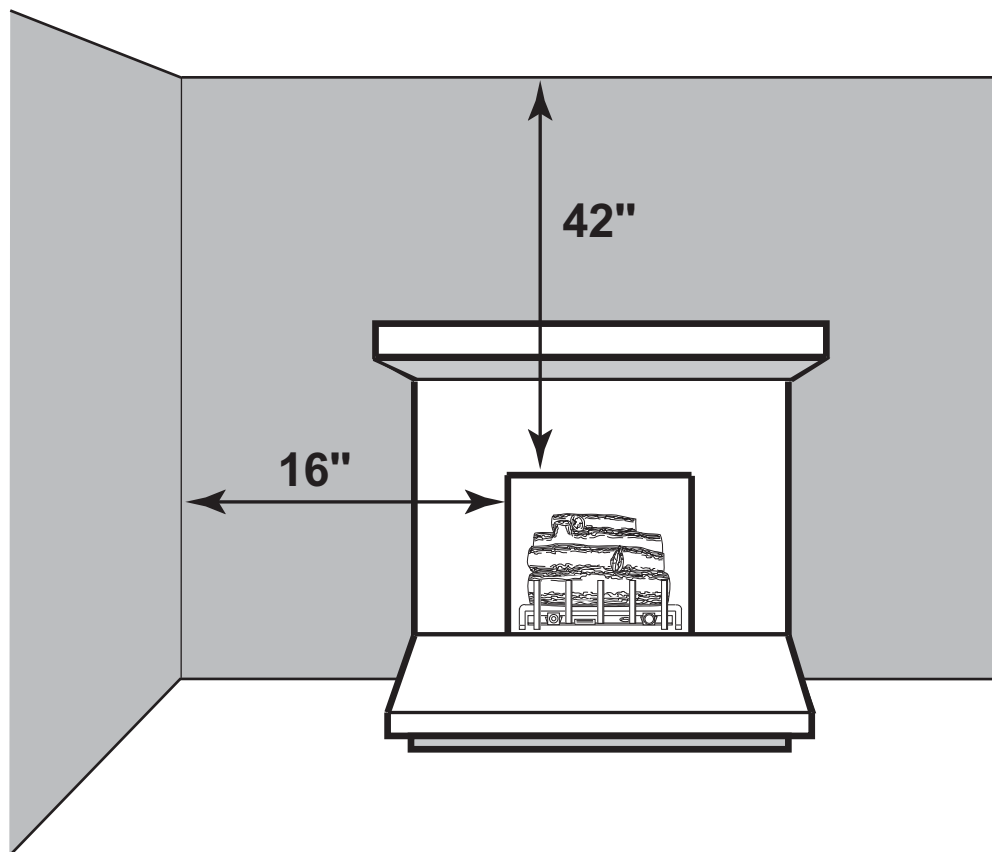

Figure 4 - Sidewall and Ceiling Clearances

CLEARANCES and HEIGHT REQUIREMENTS

Heat resistant material (minimum requirements) with no wooden mantel or other combustible projection:

To install the gas logs into a fireplace with no wooden mantel, shelf or other combustible projection above the fireplace opening, measure the heat resistant material height, per Figure 5, then see TABLE A.

Heat resistant materials such as slate and marble must be at least 1/2" thick. Sheet metal should not be installed onto combustible material.

IMPORTANT: If you cannot meet these minimum clearances you must operate the heater with chimney flue damper open. See *Installing Vented Applications* found on page 16.

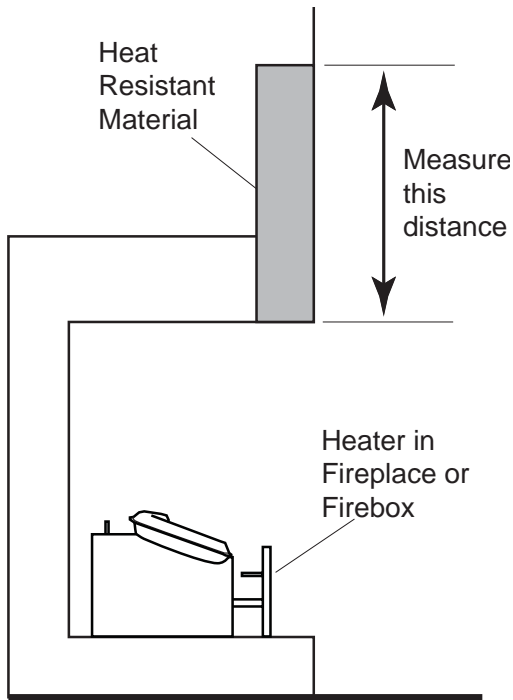

Figure 5 - Measuring Heat Resistant Material

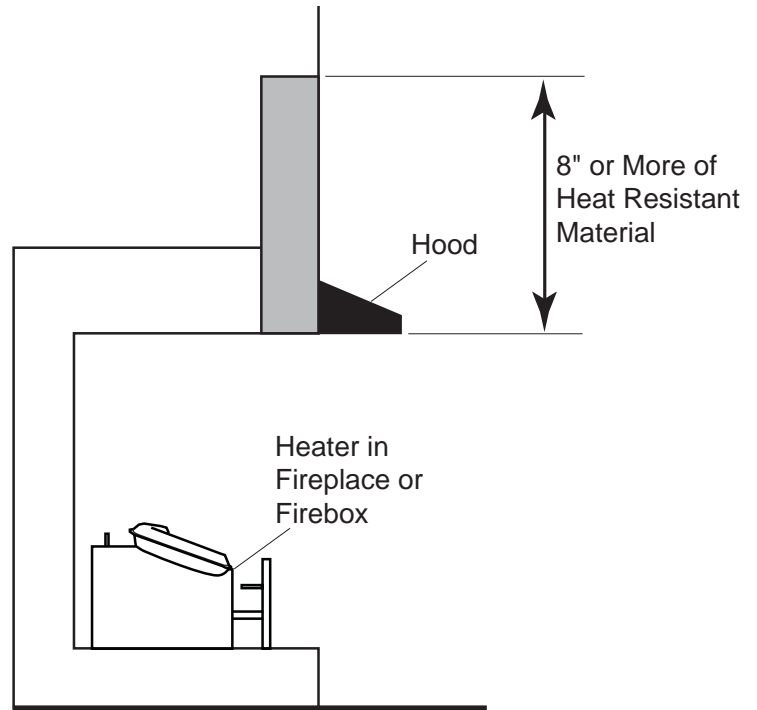

Figure 6 - Measuring Heat Resistant Material for Mantel

Heat resistant material (minimum requirements) with wooden mantel or other combustible projection:

To install the heater with a wooden mantel, shelf or other combustible projection above, first measure the heat resistant material shown in Figure 6, then see TABLE B, page 13

HEAT RESISTANT MATERIAL MEASUREMENT	EYF24/18 REQUIREMENTS FOR SAFE INSTALLATION
20" or more	Hood not required.
8" to less than 20"	Extend heat resistant material to 20" or install Hood. See Figure 6.
Less than 8"	Extend heat resistant material to at least 8" and install hood. See Figure 6. OR , extend heat resistant material to a height of at least 20".

TABLE A - Heat Resistant Material Requirements with No Mantel or Combustible Projection

CLEARANCES AND HEIGHT REQUIREMENTS

HEAT RESISTANT MATERIAL MEASUREMENT	REQUIREMENTS FOR SAFE INSTALLATION WITH WOODEN MANTEL, SHELF OR OTHER COMBUSTIBLE PROJECTION
20" or more	Hood not required. Observe profiles (side elevations) shown in <i>Figure 8</i> .
8" to less than 20"	Install hood (CABR/CABL) and observe profiles shown in <i>Figure 7</i> ; OR extend heat resistant material to at least 12" and observe profiles shown in <i>Figure 8</i> .
Less than 8"	Extend heat resistant material to at least 8", install hood (CABR/CABL) and observe profiles shown in <i>Figure 7</i> ; OR extend heat resistant material to at least 12" and observe profiles shown in <i>Figure 8</i> .

TABLE B - Heat Resistant Material Heights and Mantel Location

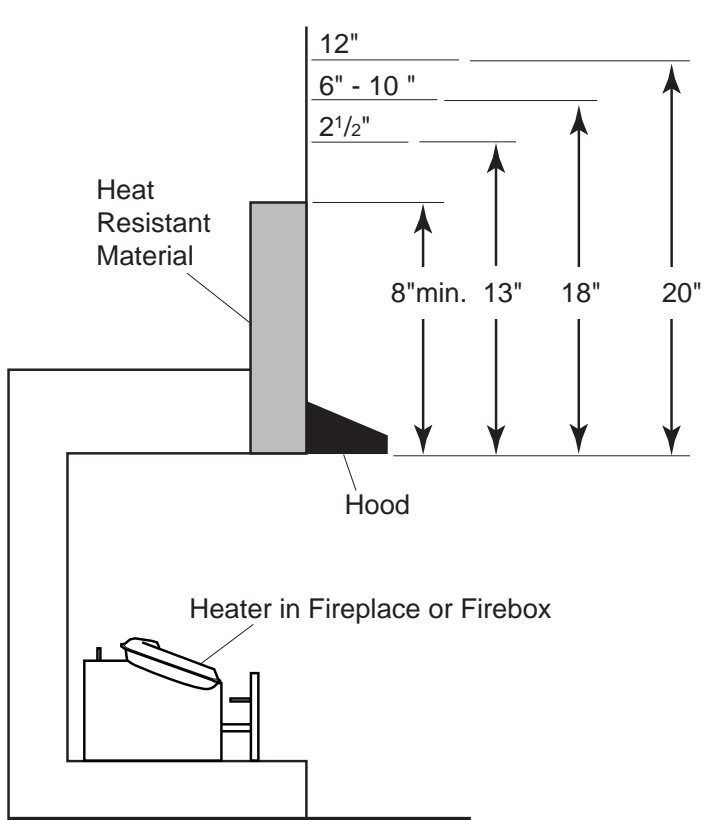

Figure 7 - Minimum Mantel Clearance with Hood

Example: A mantel may project from the wall a **maximum** of 2 1/2" at a **minimum** of 13" above the opening and a **maximum** of 10" at a **minimum** of 18" above the opening.

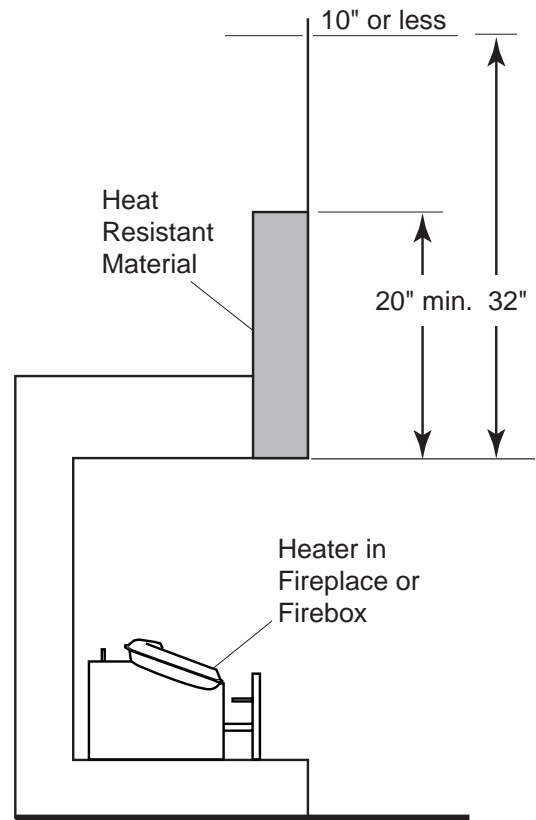

Figure 8 - Minimum Mantel Clearance with No Hood

Example: The bottom of the mantel may project from the wall a **maximum** of 10" at a **minimum** of 32" above the opening.

FLOOR CLEARANCE

The gas log heater must be installed at least 5" above any combustible flooring material, such as carpeting or tile, which is closer than 14" to the base of the fireplace. The minimum distance must be maintained from the top surface of carpeting, tile, etc. See *Figure 9*.

OR,

The gas log heater may be installed nearer to the floor if a minimum of 14" of noncombustible material such as slate or marble is installed between the base of the fireplace and the combustible flooring. See *Figure 10*.

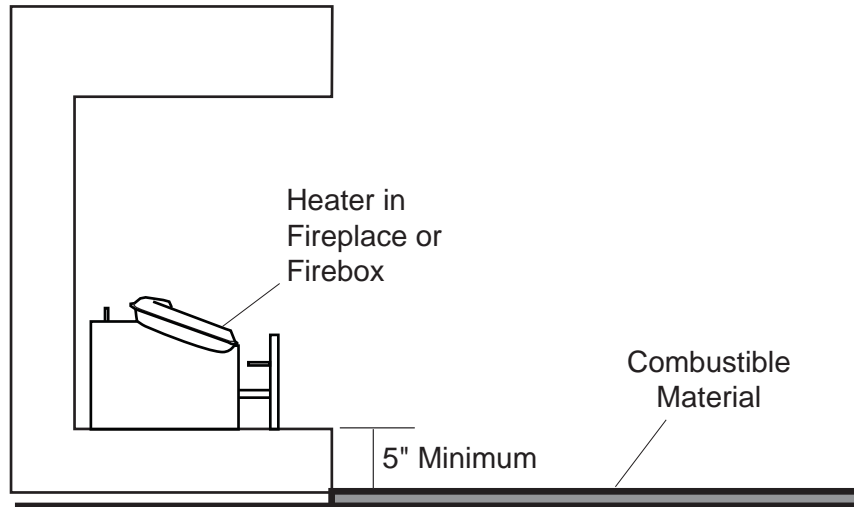

Figure 9 - Minimum Clearance above Combustible Flooring

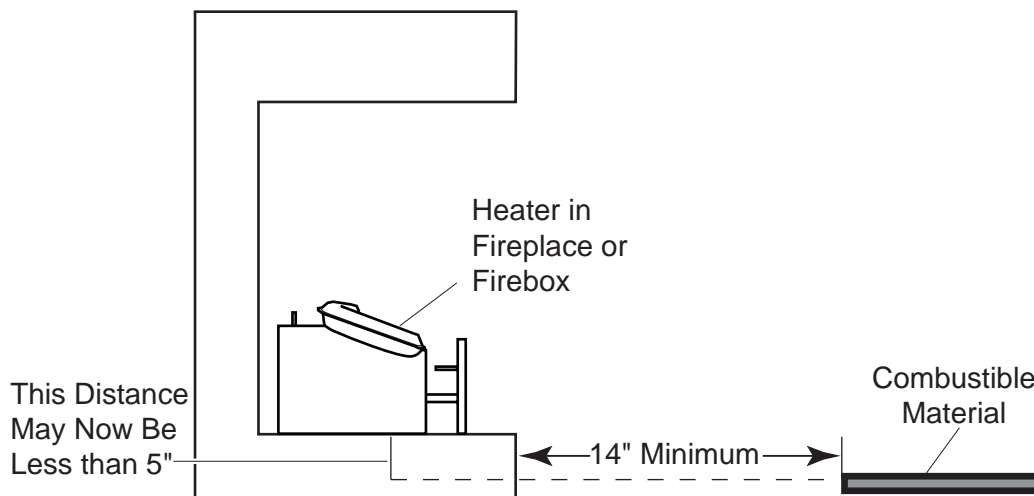

Figure 10 - Minimum Clearance above Combustible Flooring with Noncombustible Material Installed at Base of Fireplace

BEFORE FULLY INSTALLING THE UNIT:

- Turn **OFF** the gas supply to the fireplace or firebox.
- Seal any fresh air vents and/or ash clean-out doors located on the floor or wall of the fireplace. If left unsealed, drafting may cause pilot outage or sooting. Use a heat resistant sealant. **Do not seal the chimney flue damper.**

WARNING

Before installing in a solid fuel burning fireplace, The chimney flue and firebox must be cleaned of soot, creosote, ashes and loose paint by a qualified chimney cleaner.

INSTALLING VENTED APPLICATIONS

Manual and millivolt controlled gas logs may be installed as a vented decorative log set in compliance with ANSI Z21.60 and National Fuel Gas Code, Section 6.6 Since, the gas logs are operated with the damper open, non-combustible material and minimum mantel requirements do not apply.

WARNING

This appliance is for installation only in a solid fuel burning fireplace (masonry fireplace or manufactured fireplace) with a working flue and constructed of noncombustible material.

Exception: DO NOT install this appliance in a factory-built fireplace that includes instructions stating that it has not been tested or should not be used with unvented gas logs.

BEFORE INSTALLING THE APPLIANCE:

- Turn off gas supply to fireplace or firebox.
- Have the fireplace floor and chimney professionally cleaned to remove ashes, soot, creosote or other obstructions. Have this cleaning performed annually after installation.
- Seal any fresh air vents or ash clean-out doors located on floor or wall of fireplace. If not, drafting may cause pilot outage or sooting. Use a heat-resistant sealant. Do not seal chimney flue damper.

Install and operate the appliance as directed in this manual.

DAMPER STOP INSTALLATION:

A damper stop must be provided with the unit. Contact your dealer to obtain one. The damper stop must be installed as shown in *Figure 11* to prevent full closure of the fireplace damper blade and provide a minimum 29 square inch flue opening.

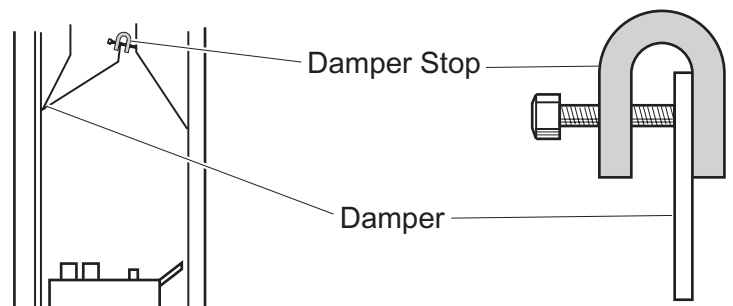

Figure 11 - Damper Stop Installation.
(See **WARNING** at top of next page.)

INSTALLING VENTED APPLICATION

WARNING

The fireplace and gas logs function as a system. If the fireplace is spilling into the room (check with a match or a smoke stick), reposition the damper clamp until a positive draft is obtained by opening the damper. If negative pressure in home prevents having a positive draft, contact your dealer for assistance.

PLACING AND SECURING APPLIANCE

WARNING

You must secure the gas log heater to the fireplace floor. If not, the entire unit may move when you adjust the controls. Movement of unit may cause shifting of the gas logs which leads to sooting and improper burning.

Special care is required if you are installing the unit into a sunken fireplace. You must raise the fireplace floor to allow access to gas log controls. This will insure adequate air flow and guard against sooting. Raise the fireplace floor using noncombustible materials, as described in *Placement in a Fireplace with Restrictive Barrier* on page 10.

ASSEMBLY PROCEDURE:

1. Center the gas log unit in the fireplace or firebox.
2. **Installing Grate:** Insert longest middle grate bar in one of the two square holes in control panel. See Figure 12. Be sure grate is centered. Sit horizontal bar inside two hooks on front of control panel. See Figure 12. Make certain front feet of grate are located inside front edge of fireplace or firebox.
3. Anchor holes are located on the flange of the unit. See Figure 12. After centering the burner correctly, mark the hole positions on the fireplace/firebox floor. Drill two (2) $\frac{5}{32}$ " diameter holes approximately $1\frac{1}{2}$ " deep.
4. Anchor the unit to the fireplace/firebox floor using the screws provided. See Figure 12.

NOTE: Proper installation of the burner is essential to prevent any movement of the gas logs and controls during operation.

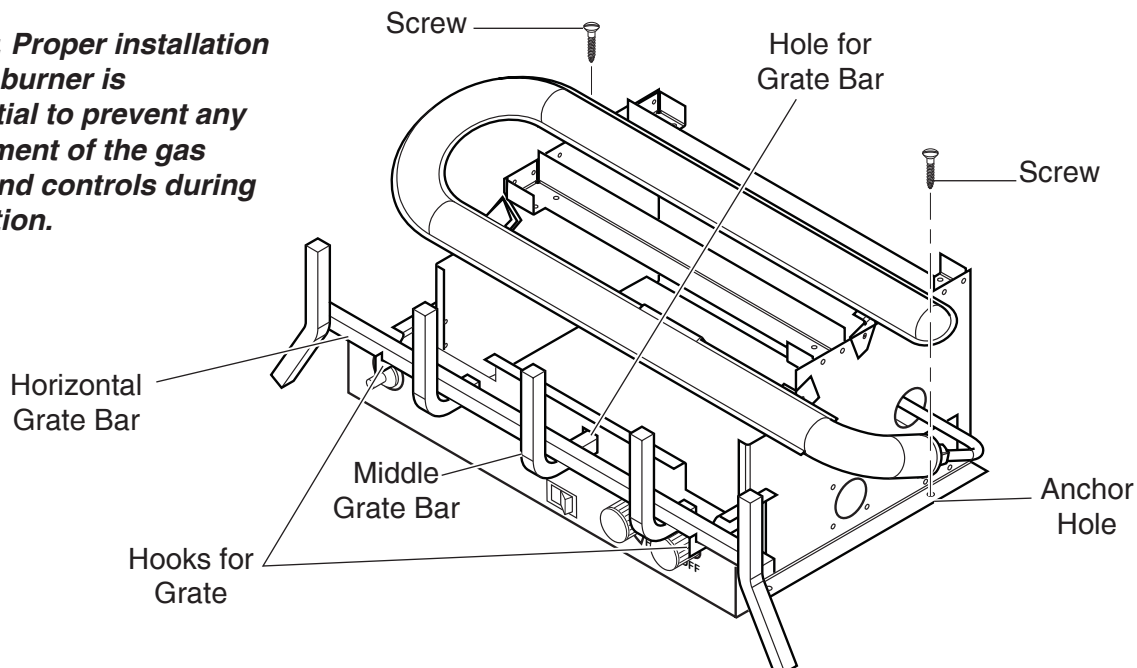

Figure 12 - Installing Grate and Securing Heater to Floor of Fireplace/Firebox

NOTICE: A qualified gas appliance installer must connect the heater to the gas supply. Consult all local codes.

CAUTION

Use new black iron or steel pipe. Internally tinned copper or copper tubing can be used per National Fuel Code, section 2.6.3, providing gas meets hydrogen sulfide limits, and where permitted by local codes. Gas piping system must be sized to provide minimum inlet pressure (Listed on Data Plate) at the maximum flow rate (BTU/Hr). Undue pressure loss will occur if the pipe is too small.

A manual shutoff valve must be installed upstream of the appliance. Union tee and plugged 1/8" NPT pressure tapping point should be installed upstream of the appliance. See Figure 13.

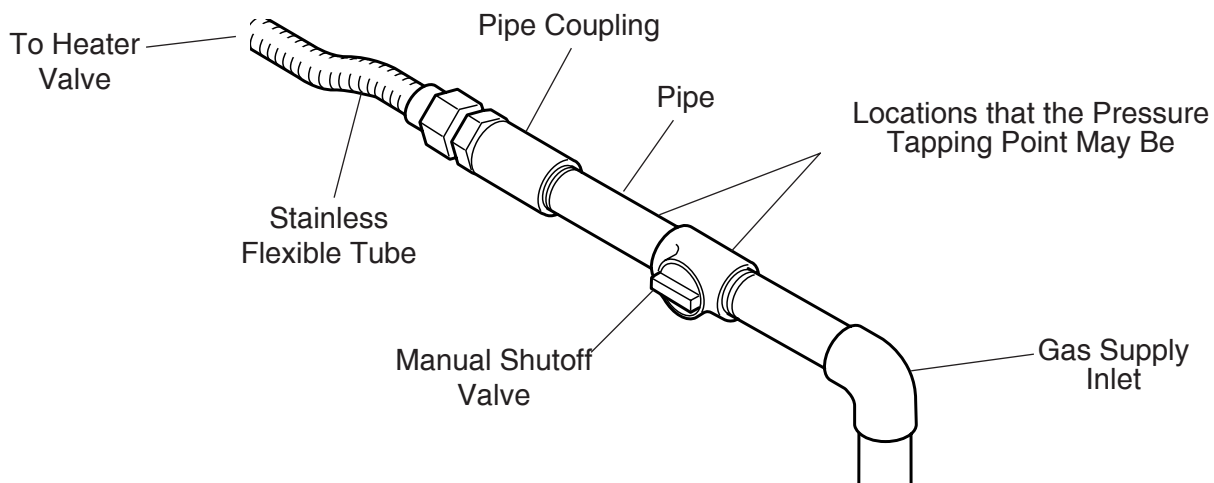

Figure 13 - Gas Connection

IMPORTANT: Hold heater valve firmly with a wrench to prevent movement when connecting to inlet pipe.

CAUTION

CHECK GAS TYPE: The gas supply must be the same as stated on the heater's rating plate. If the gas supply is different, **DO NOT INSTALL THE HEATER.** Contact your dealer for the correct model.

Always use an external regulator for all propane/LPG heaters and high pressure one to two-pound systems only, to reduce the supply tank pressure to a maximum of 13" w.c. This is in addition to the internal regulator in the heater valve.

CHECKING GAS PRESSURE

WARNING

Connecting directly to an unregulated propane/LPG tank can cause an explosion.

The heater gas inlet connection is a $\frac{3}{8}$ " NPT at the valve. All units have the inlet connection on the right side, when you face the unit. To connect from the opposite side, route the pipe under the rear portion of the unit.

When tightening up the joint to the valve, hold the valve securely to prevent movement.

Test all gas joints from the gas meter to the heater valve for leaks using a gas analyzer or soap and water solution after completing connection. **DO NOT USE AN OPEN FLAME.**

Check the gas pressure with the appliance burning and the control set to **HIGH**.

MANUAL CONTROL *(Figure 14)*

The pressure regulator is preset and locked to discourage tampering. If the pressure is not as specified, replace the regulator with the correct part from the parts list in this manual.

Remove $\frac{1}{8}$ " NPT plug, located on side of regulator body. Install fitting and tubing to pressure gauge. After taking pressure reading, reinstall test plug. Check for gas leaks.

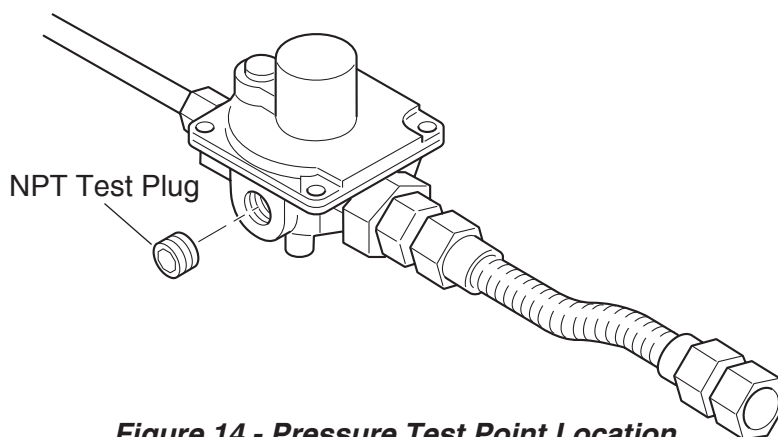
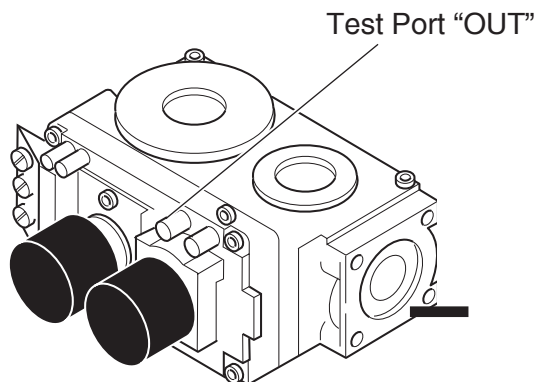

**Figure 14 - Pressure Test Point Location
Manual Control**

MILLIVOLT CONTROL *(Figure 15)*

The valve regulator controls the burner pressure which should be checked at the pressure test point.

Turn captured screw counter clockwise two or three turns and then place tubing to pressure gauge over test point (Use test point "OUT" closest to control knob). After taking pressure reading, be sure and turn captured screw clockwise firmly to re-seal. Do not over torque. Check for gas leaks.



**Figure 15 - Pressure Test Point Location
Millivolt Control**

CAUTION

Label all wires prior to disconnection when servicing controls. Wiring errors can cause improper and dangerous operation. Verify proper operation after servicing.

The millivolt valve is a self-powered combination gas control **THAT DOES NOT REQUIRE 110 VAC TO OPERATE.**

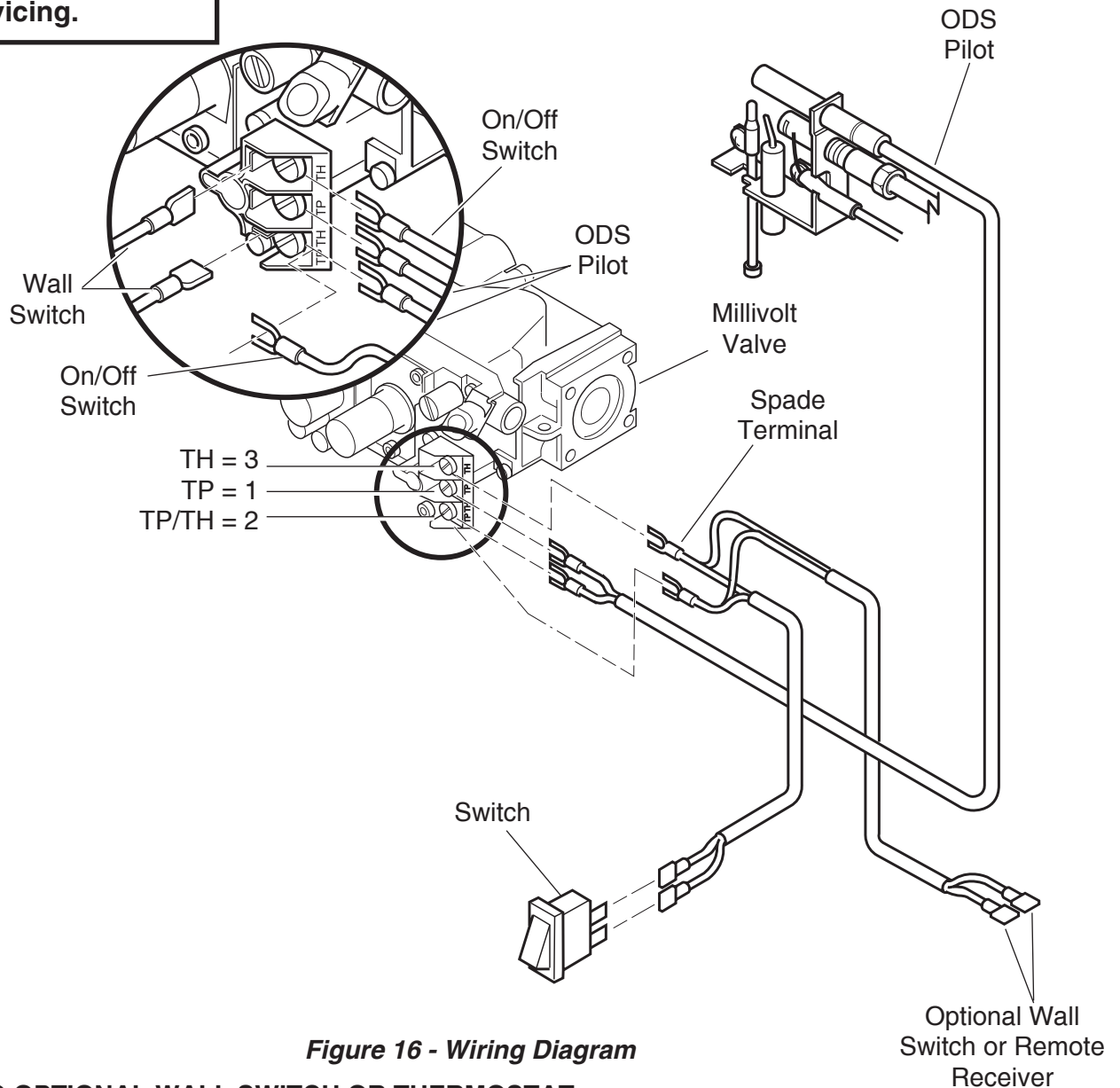

Figure 16 - Wiring Diagram

CONNECTING OPTIONAL WALL SWITCH OR THERMOSTAT

1. Use 18 AWG, two-wire cable, 20 feet maximum length.
2. At one end of the cable, connect both wires to the wall switch or thermostat. At the other end, connect one wire to TP/TH and one wire to TH. The color of the wires does not matter. Or you can hook the wall switch or thermostat to wires on the unit.

ELECTRICAL WIRING (MILLIVOLT)

CONNECTING OPTIONAL REMOTE RECEIVER

FOLLOW INSTRUCTIONS SUPPLIED WITH THE REMOTE.

1. Connect the wires to the two .25" male connectors located on the left side of the valve when facing the unit (See Figure 16, page 19). Do not let wire touch grate or burner.
2. Stick velcro pads with self-adhesive backing to the right side of remote receiver and to the left side of the unit. See Figure 17.
3. Attach remote receiver with velcro pads. Control switch must face forward.

NOTE: Heat reduces battery life. You can protect the receiver and extend battery life by mounting the receiver in a wall or other location outside the fireplace.

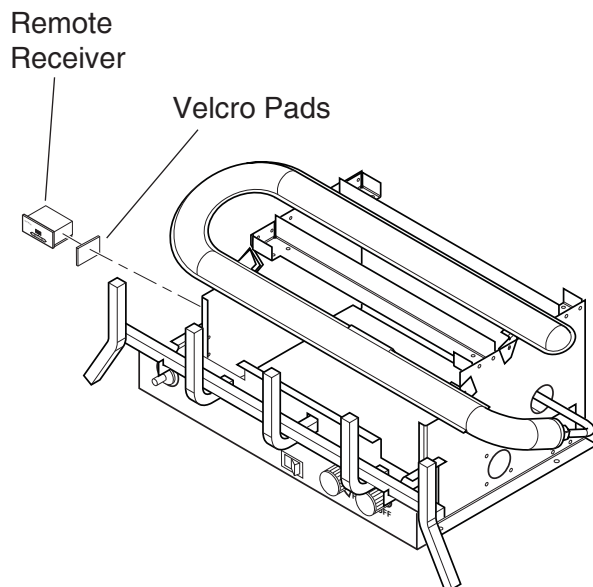

Figure 17 - Installing Remote Receiver

CHECKING SYSTEM OPERATION

The millivolt system and individual components may be checked with a millivolt meter having a 0-1000 mV range. Conduct each check shown in chart below by connecting meter test leads to terminals as indicated.

CHECK TEST	TO TEST	CONNECT METER LEADS TO TERMINALS	ON/OFF CONTACTS	METER READING SHOULD BE
A	COMPLETE SYSTEM	2 & 3	CLOSED	MINIMUM 175mV
B	THERMOPILE OUTPUT	1 & 2	OPEN	MINIMUM 500mV

A. COMPLETE MILLIVOLT SYSTEM CHECK

("A" Reading - On/Off Switch contacts CLOSED - Control Knob "ON" - Main burner should come ON)

- a. If the reading is more than 175 millivolts and the automatic valve still does not come on, replace the control.
- b. If the closed circuit reading ("A" reading) is less than 175 millivolts, determine cause for low reading, proceed to Section B below.

B. Thermopile Output Reading Check

("B" Reading - On/Off Switch contacts OPEN - Main burner OFF)

1. Check gas pressure to the unit. If gas pressure is within minimum and maximum on data plate, then check pilot voltage, 500 millivolts minimum. If the minimum millivolt reading is not obtainable, replace pilot.

Before you begin — This unit is supplied with a four ceramic fiber log units. Do not handle the log unit with your bare hands. **Always wear gloves to prevent skin irritation from ceramic fibers.** After handling the log unit, wash your hands gently with soap and water to remove any traces of fibers.

WARNING

The positioning of the log unit is critical to the safe and clean operation of this heater. Sooting and other problems may result if the logs are not properly and firmly positioned in the appliance. **Never add additional logs or embellishments such as pine cones, vermiculite or rock wool to the heater. Only use the log unit supplied with the unit.**

Failure to position the parts in accordance with diagrams below or to use only parts specifically approved for this heater may result in property damage or personal injury.

INSTALLING EYF24-F LOG UNIT ON BURNER

1. Install Main Log (#1) on middle and rear supports of base. Tabs should fit inside log center opening. Check log position and stability. *See Figure 18.*
2. Install Front Log (#2) in front of burner and behind grate. *See Figure 18.*
3. Rest rear end Top Left Log (#3) in the indentation on the main log. Line up hole in bottom of Top Left Log (#3) with slot on Front Log. *See Figure 18.*
4. Position rear end of Top Right Log (#4) on indentation of main log. Rest front end of Top Right Log (#4) on front lot. *See Figure 18.*

PLACING THE DECORATIVE ROCK

CAUTION

DO NOT sprinkle volcanic rock on the logs or around the pilot or the main burner. This may cause sooting. Only place volcanic rock on the floor of the fireplace.

During initial operation of the new heater, burning logs will give off a paper burning smell and orange flames will be present. Simply open the windows for a few hours to vent the odor.

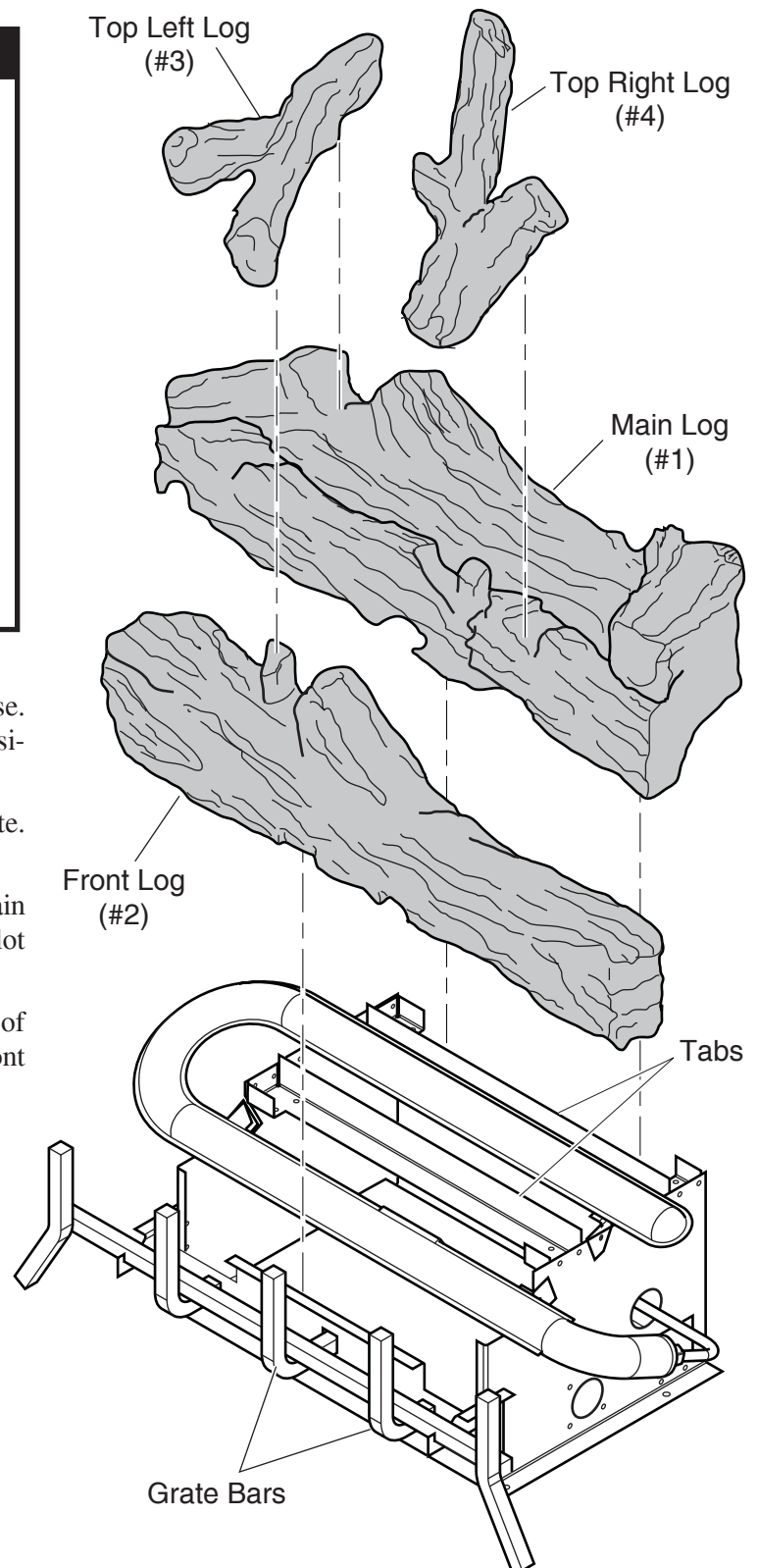

Figure 18 - Installing EYF24-F Logs on Burner

LOG PLACEMENT

INSTALLING EYF18-R LOG SET ON UNIT



Figure 19 - Installing Rear Log (#1)

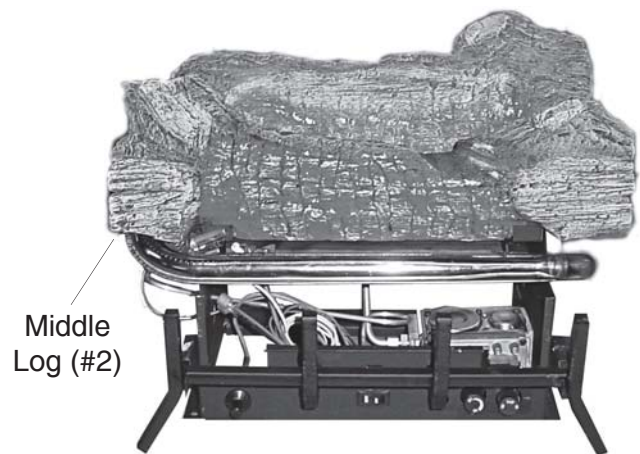

Figure 20 - Installing Middle Log (#2)

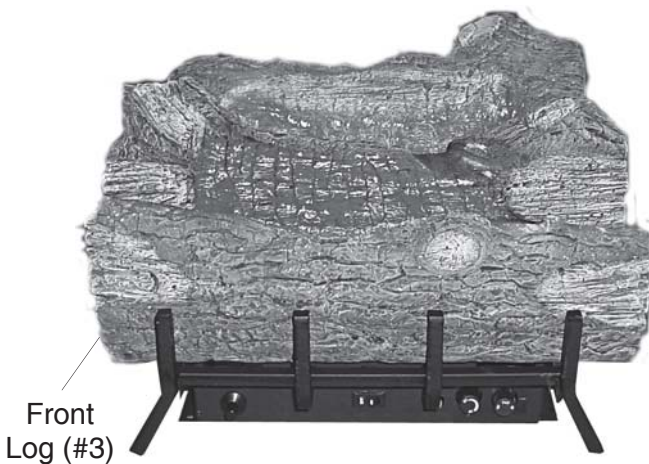

Figure 21 - Installing Front Log (#3)



Figure 22 - Installing Top Log (#4)

1. Place Rear Log (#1) on rear support. *See Figure 19.*
2. Place Middle Log (#2) on middle support. *See Figure 20.*
3. Place Front Log (#3) in between burner and grate. *See Figure 21.*
4. Rest Top Log (#4) in front and middle log cutouts. *See Figure 22.*

NOTE: Logs #1, #2 and #3 have ridges on the bottom which secure the logs to burner frame. After installing each log, check to be sure it is stable.



Figure 23 - EYF18-R Logs on Base

INSTALLING EYF24-R OR EYF30-R LOG SET ON UNIT

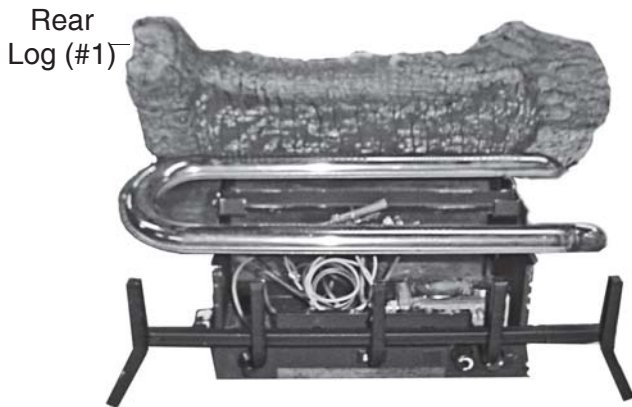

Figure 24 - Installing Rear Log (#1)



Figure 25 - Installing Middle Log (#2)



Figure 26 - Installing Front Log (#3)

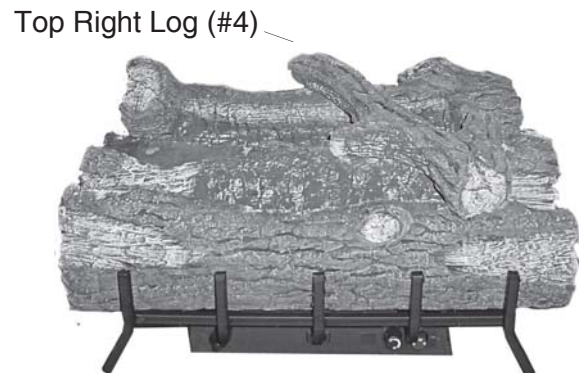

Figure 27 - Installing Top Right Log (#4)



Figure 28 - Installing Top Left Log (#5)



Figure 23 - EYF24-R Logs on Base

1. Place Rear Log (#1) on rear support. *See Figure 24.*
2. Place Middle Log (#2) on middle support. *See Figure 25.*
3. Place Front Log (#3) in between burner and grate. *See Figure 26.*
4. Place Top Right Log (#4) in bottom log cutouts. *See Figure 27.*
5. Rest Top Left Log (#5) in front and middle log cutouts. *See Figure 28.*

NOTE: Installation instructions are the same for 24" and 30" log sets. Pictures used in this manual illustrate the 24" set. Some variation may exist between the images and the set included with this manual.

NOTE: Logs #1, #2 and #3 have ridges on the bottom which secure the logs to burner frame. After installing each log, check to be sure it is stable.

FLAME APPEARANCE

Flames from the pilot, front and rear burner should be visually checked as soon as the heater is installed. In addition, periodically check the flames visually during operation.

CHECKING THE PILOT FLAME

The pilot flame must always be present when the heater is in operation. It should just touch the top of the thermocouple tip for natural. See Figures 30 and 32 for correct pilot flame.

If the pilot flame does not touch the thermocouple, then the main burner cannot function reliably. See Figures 31 and 33 for incorrect shape of pilot flame.

MILLIVOLT CONTROL

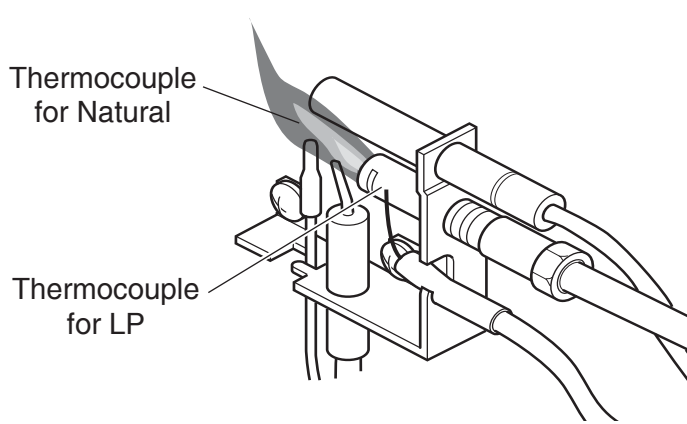

Figure 30 - Correct Appearance of Pilot Flame

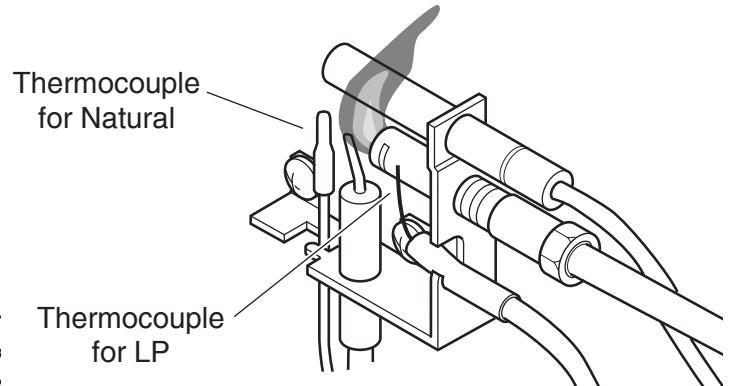

Figure 31 - Incorrect Appearance of Pilot Flame

MANUAL CONTROL

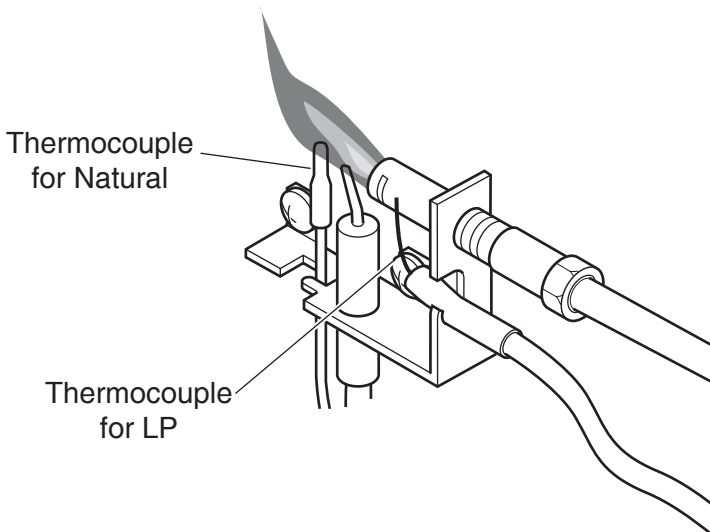

Figure 32 - Correct Appearance of Pilot Flame

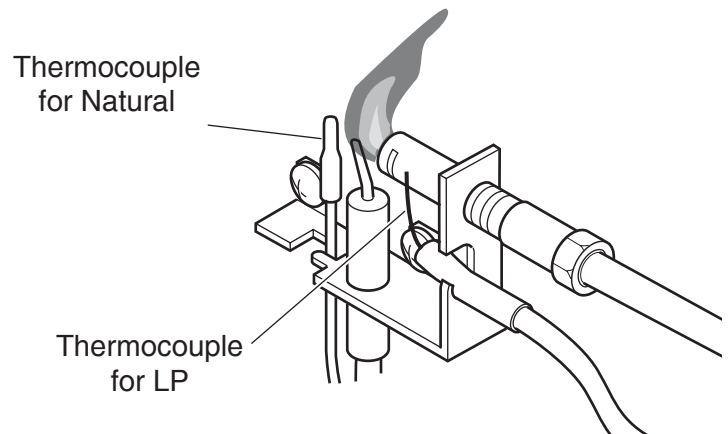

Figure 33 - Incorrect Appearance of Pilot Flame

CHECKING THE BURNER FLAME

In normal operation at full rate after 15 minutes, the following flame appearances should be observed:

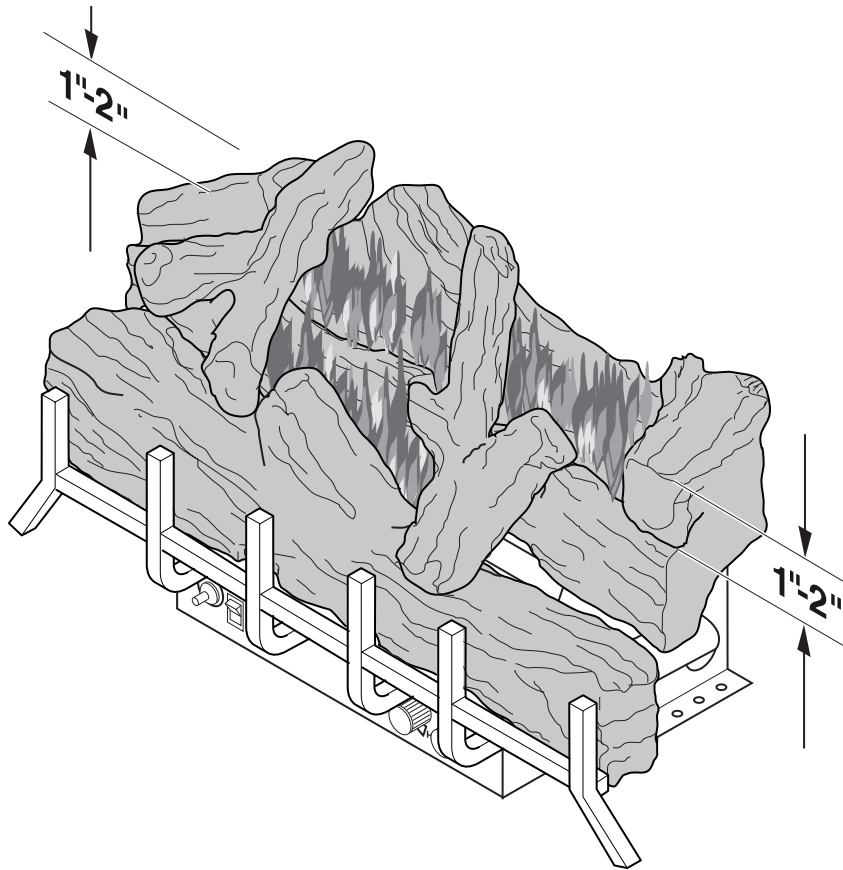

Figure 34 - Correct Appearance of Rear Flames

The left and right flames should be yellow and extend 1" to 2" above the log top surfaces. The yellow flames should **not** contact the logs.

OPERATING INSTRUCTIONS

Avoid any drafts that alter burner flame patterns. Do not allow fans to blow directly into the fireplace. Do not place a blower inside the burn area of the firebox. Ceiling fans may create drafts that alter flame patterns. Sooting and improper burning will result.

During manufacturing, fabricating and shipping, various components of this appliance are treated with certain oils, films or bonding agents. These chemicals are not harmful, but may produce annoying smoke and smells as they are burned off during the initial operation of the appliance, possibly causing headaches or eye or lung irritation. *This is a normal and temporary occurrence.*

The initial break-in operation should last two to three hours with the burner at the highest setting. Provide maximum ventilation by opening windows or doors to allow odors to dissipate. Any odors remaining after this initial break-in will be slight and will disappear with continued use.

This appliance must not be used with glass doors in the closed position. This can lead to pilot outages and severe sooting outside the fireplace.

OPERATING INSTRUCTIONS

FOR YOUR SAFETY READ BEFORE LIGHTING

WARNING

If you do not follow these instructions exactly, a fire or explosion may result causing property damage, personal injury or loss of life.

- A.** This appliance is equipped with an ignition device which automatically lights the pilot. Do not try to light the unit by hand.
- B.** BEFORE OPERATING smell all around the appliance area for gas. Be sure to smell next to the floor because some gas is heavier than air and will settle on the floor.

WHAT TO DO IF YOU SMELL GAS:

- Do not attempt to light any appliance.
 - Do not touch any electric switch; do not use any phone in your building.
 - Immediately call your gas supplier from a neighbor's phone. Follow the gas supplier's instructions.
 - If you cannot reach your gas supplier, call the fire department.
- C.** Use only your hand to push in, or turn the gas control knob. Never use tools. If the knob will not push in or turn by hand, don't try to repair it. Call a qualified service technician. Force or attempted repair may result in a fire or explosion.
- D.** Do not use this appliance if any part of it has been under water. Immediately call a qualified service technician to inspect the appliance and to replace any part of the control system and any gas control that has been under water.

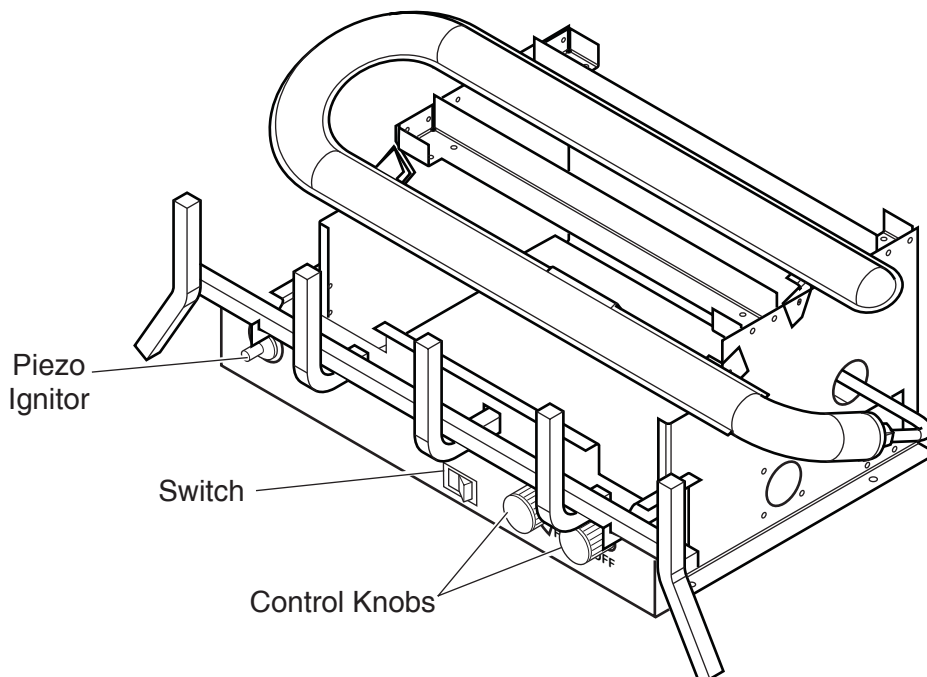





Figure 35 - Location of Piezo Ignitor, Control Knobs and Switch on Millivolt Unit

MANUAL CONTROL LIGHTING INSTRUCTIONS

1. STOP! Read the safety information.
2. Make sure the manual shutoff valve is fully open.
3. This heater is equipped with an ignition device (piezo) which automatically lights the pilot.
4. See *Figure 35, page 26* for the location of the piezo ignitor and control knob. Push in gas control knob slightly and turn control knob clockwise  to the OFF position.
NOTE: Knob cannot be turned to OFF unless knob is pushed in slightly. Do not force.
5. Wait 5 minutes to clear out any gas. Then smell for gas, including near the floor. If you smell gas STOP! Follow the instructions under *What to Do if You Smell Gas, page 26*. If you do not smell gas, go to the next step.
6. From OFF position, push in gas control knob slightly and turn counterclockwise  to the IGN position. *Figure 36*. Push in and hold control knob for 5 seconds.
NOTE: If you are running the heater for the first time, it will be necessary to press in the control knob for 30 seconds to allow air to bleed out of the gas piping.
7. With the control knob pushed in, push and release the piezo ignitor button to light the ODS pilot. The pilot is located behind the front log and front burner. If piezo ignitor does not light the pilot, see *Match Lighting Instructions, page 29*.
8. Hold the control knob in for an additional 10 seconds to prevent the ODS pilot from shutting off the gas while the thermocouple is warming up.
9. Release the control knob.
 - If the knob does not pop out when released, stop and immediately call your service technician or gas supplier.
 - If the ODS pilot will not stay lit after several tries, push and turn the gas control knob clockwise  to OFF and wait 15 seconds. Repeat steps 6 through 9.
10. Push in control knob and turn counterclockwise  to the HIGH setting. At this location the control knob will pop out when positioned correctly. The knob can now be positioned at any position between HIGH and LOW. See *Figures 37 and 38*.

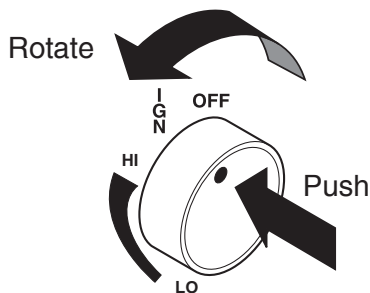

Figure 36 - IGN Position

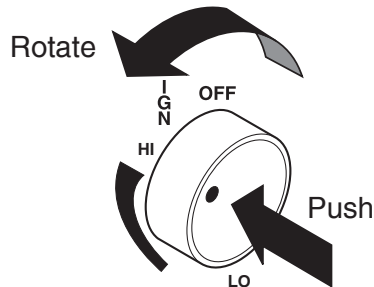

Figure 37 - HIGH Position

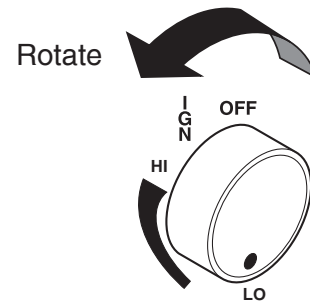

Figure 38 - LOW Position

WARNING



Wait 30 seconds before readjusting the heater when the control knob has been turned down to a lower setting.

TO TURN OFF HEATER

1. Turn control knob clockwise  to OFF position to completely shut off the heater.
2. If applicable: Turn off all electric power to the heater.

OPERATING INSTRUCTIONS

MILLIVOLT CONTROL LIGHTING INSTRUCTIONS

1. STOP! Read the safety information label.
2. Make sure the manual shutoff valve is fully open.
3. This gas log set is equipped with an ignition device (piezo) which automatically lights the pilot. If piezo ignitor does not light the pilot, see instructions for *Match Lighting Instructions*, page 29.
4. Turn gas control knob clockwise  to the OFF position. Turn ON/OFF switch to OFF position.
5. Wait (5) minutes to clear out any gas. Then smell for gas, including near the floor. If you smell gas, STOP! Follow "B" in the safety information label. If you don't smell gas, go to next step.
6. From OFF position, turn the gas control knob counterclockwise  to IGN position. Push in control knob for 5 seconds.
7. With the control knob pushed in, push in and release the piezo ignitor button to light the pilot.
8. Continue pushing the control knob in for a further 60 seconds to prevent the flame detector from shutting off the gas while the probe is warming up. Release the control knob.
9. Turn gas control knob counterclockwise  to the ON position.
10. After the pilot has been lit for one minute, the burners can be turned on. Turn the ON/OFF switch to ON position.
11. If the gas logs will not operate, follow the instructions *To Turn Off Gas To Appliance* below and call your service technician or gas supplier.

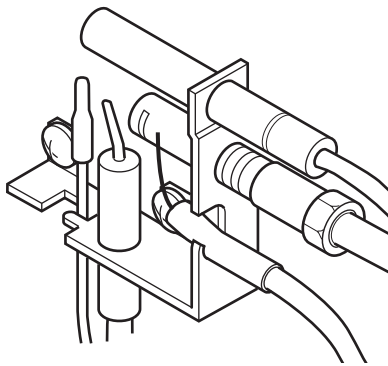

Figure 39 - Pilot

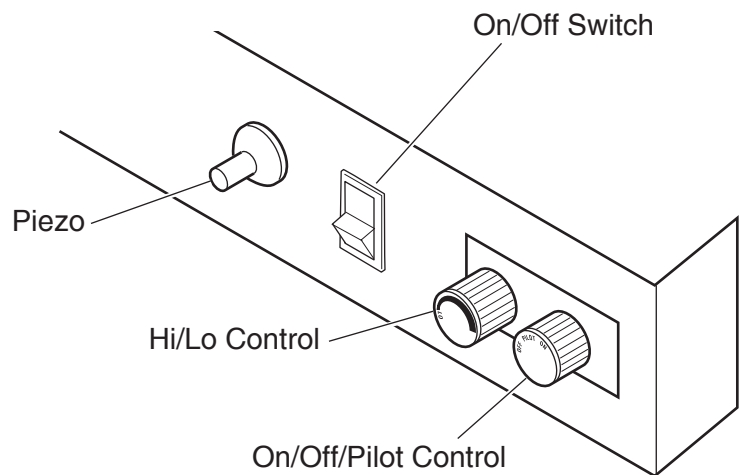



Figure 40 - Control Cover Plate for Millivolt

TO TURN OFF HEATER

1. Turn control knob clockwise  to **OFF** position to completely shut off the heater.
2. If applicable: Turn ON/OFF switch to OFF position and/or set thermostat (if present) to lowest setting.
3. If applicable: Turn off all electric power to the heater.

OPERATING INSTRUCTIONS AND CLEANING AND SERVICING

MATCH LIGHTING INSTRUCTIONS

1. Remove any items necessary for easy access to the pilot (for example: logs, screens, etc.).
2. Follow appropriate lighting instructions found previously. Instead of pushing and releasing the piezo button, light a match and hold the flame to the end of the pilot and ignite the pilot.
3. After control knob has been released and pilot stays lit, reinstall any items that were removed for pilot access.
4. Call a qualified service technician for repair or replacement of the piezo ignitor.

CLEANING AND SERVICING

Annual inspection and cleaning by your dealer or qualified service technician is recommended to prevent malfunction and/or sooting.

WARNING

Turn off heater and allow to cool before cleaning.

Disconnect electrical power (optional blower) before cleaning or servicing.

Remove logs, handling carefully by holding gently at each end. Gloves are recommended to prevent skin irritation from ceramic fibers. If skin becomes irritated, wash gently with soap and water. See *Log Placement, pages 21-23* for correct log placement.

PERIODIC CLEANING - See parts diagram for location of items discussed below.

- Do not use cleaning fluid to clean logs or any part of heater.
- Brush logs with soft bristle brush or vacuum with brush attachment.
- Vacuum loose particles and dust from the front and rear burner, control and piezo covers and grate weldment.
- Inspect and clean burner air intake holes. Remove lint or particles with vacuum, brush, or pipe cleaners. Failure to keep air intake holes clean will result in sooting and poor combustion.
- External case should be dusted and wiped with a wet soapy cloth.

ANNUAL CLEANING/INSPECTION - See parts diagram for location of items discussed below.

- Inspect and clean burner air intake holes. Remove lint or particles with vacuum, brush or pipe cleaners. Failure to keep air intake holes clean will result in sooting and poor combustion.
- Inspect and clean all burner ports.
- Inspect ODS pilot for operation and accumulation of lint at air intake holes.
- Verify flame pattern and log placement for proper operation.
- Verify smooth and responsive ignition of main burner and rear burner.

TROUBLESHOOTING

WARNING

Turn appliance OFF and allow to cool before servicing. Only a qualified service person should service and repair the heater.

Note: All troubleshooting items are listed in order of operation.

OBSERVED PROB-	POSSIBLE CAUSE	REMEDY
When ignitor button is pressed, there is no spark at ODS/pilot.	<ol style="list-style-type: none"> 1. Ignitor electrode positioned wrong. 2. Ignitor electrode is broken. 3. Ignitor electrode not connected to ignitor cable. 4. Ignitor cable pinched or wet. Keep ignitor cable dry. 5. Broken ignitor cable. 6. Bad piezo ignitor. 	<ol style="list-style-type: none"> 1. Replace ignitor. 2. Replace ignitor. 3. Reconnect ignitor cable. 4. Free ignitor cable if pinched by any metal or tubing. 5. Replace ignitor cable. 6. Replace piezo ignitor.
Appliance produces unwanted odors.	<ol style="list-style-type: none"> 1. Appliance burning vapors from paint, hair spray, glues, etc. 2. Gas leak. 3. Initial burn off. 	<ol style="list-style-type: none"> 1. Ventilate room. Stop using odor causing products while heater is running. 2. Locate and correct all leaks. 3. Ventilate room and turn unit on high until odor is gone. Odor should be gone after 2 to 3 hours of continuous use.
Appliance shuts off during use.	<ol style="list-style-type: none"> 1. Not enough fresh air is available for ODS/ pilot to operate. 2. Low line pressure. 3. ODS/pilot is partially clogged. 4. Defective Thermopile. 5. Restrictions in incoming air flow. 	<ol style="list-style-type: none"> 1. Open window and/or door for ventilation. 2. Contact local gas company. 3. Clean ODS/pilot. 4. Check pilot flame, check wire connections, check output, should be 325 millivolts across TH/TP and TP Terminals with ON/OFF switches off. 5. Check for bottom riser on glass door, sunken fireplace, excessive lava rock/cinders densely packed against grate.
Gas odor even when control knob is in OFF position.	<ol style="list-style-type: none"> 1. Gas leak. 2. Control valve defective. 	<ol style="list-style-type: none"> 1. Locate and correct all leaks. 2. Replace control valve.
When ignitor button is pressed, there is spark at ODS pilot, but no ignition.	<ol style="list-style-type: none"> 1. Gas supply turned off or manual shutoff valve closed. 2. Control knob not in PILOT position. 3. Control knob not pressed in while in PILOT position. 4. Air in gas lines when installed. 5. ODS/pilot is clogged. 6. Gas regulator setting is not correct. 	<ol style="list-style-type: none"> 1. Turn on gas supply or open manual shutoff valve. 2. Turn control knob to PILOT position. 3. Press in control knob while in PILOT position. 4. Continue holding down control knob. Repeat igniting operation until air is removed. 5. Replace ODS/pilot assembly or get it serviced. 6. Replace gas regulator

WARNING

If the gas quality is bad, your pilot may not stay lit, the burners may produce soot and the heater may backfire when lit. If the gas quality or pressure is low, contact your local gas supplier immediately.

OBSERVED PROB-	POSSIBLE CAUSE	REMEDY
ODS/pilot lights, but flame goes out when control knob is released.	<ol style="list-style-type: none"> Control knob not fully pressed in. Control knob not pressed in long enough. Manual shutoff valve not fully open. Thermocouple connection loose at control valve. Pilot flame not touching thermocouple, which allows thermocouple to cool, causing pilot flame to go out. This problem could be caused by either low gas pressure, or a dirty or partially clogged ODS/pilot. Thermocouple damaged. Control valve damaged. 	<ol style="list-style-type: none"> Press in control knob fully. After ODS/pilot lights, keep control knob pressed in for 30 seconds. Fully open manual shutoff valve. Hand tighten until snug, then tighten 1/4 turn more. Contact local gas company. Replace thermocouple. Replace control valve
Burner does not light after ODS/pilot is lit.	<ol style="list-style-type: none"> Burner orifice is clogged. Burner orifice diameter is too small. Inlet gas pressure is too low. 	<ol style="list-style-type: none"> Clean burner or replace burner orifice. Replace burner orifice. Contact qualified service person.
Burner backfires during combustion.	<ol style="list-style-type: none"> Manifold pressure is too low. Burner orifice is clogged. 	<ol style="list-style-type: none"> Contact local gas company. Clean burner or replace burner orifice.
Slight smoke or odor during initial operation.	<ol style="list-style-type: none"> Burner orifice is clogged or damaged. Burner is damaged. Gas regulator defective. 	<ol style="list-style-type: none"> Clean burner or replace burner orifice. Replace burner. Replace gas regulator.
Logs appear to smoke after initial operation.	<ol style="list-style-type: none"> Vapors from paint or curing process of logs. 	<ol style="list-style-type: none"> Problem will stop after a few hours of operation. Run the heater with the damper open if you have one, or open a window for the first few hours. Log heater is intended to be smokeless. Turn OFF heater and call qualified service person.
Heater produces a whistling noise when burner is lit.	<ol style="list-style-type: none"> Turning control knob to HIGH position when burner is cold. Air in gas line. Dirty or partially clogged burners orifice. 	<ol style="list-style-type: none"> Turn control knob to LOW position and let warm up for a minute. Operate burner until air is removed from line. Have gas line checked by local gas company. Clean burner or replace burner orifice.
No gas to pilot.	<ol style="list-style-type: none"> LP-regulator shut down due to inlet pressure too high. 	<ol style="list-style-type: none"> Verify LP tank regulator is installed and set at 11" to 13" w.c. Replace regulator on heater.

ILLUSTRATED PARTS BREAKDOWN

WARNING

Failure to position the parts in accordance with these diagrams or failure to use only parts specifically approved with this appliance may result in property damage or personal injury.

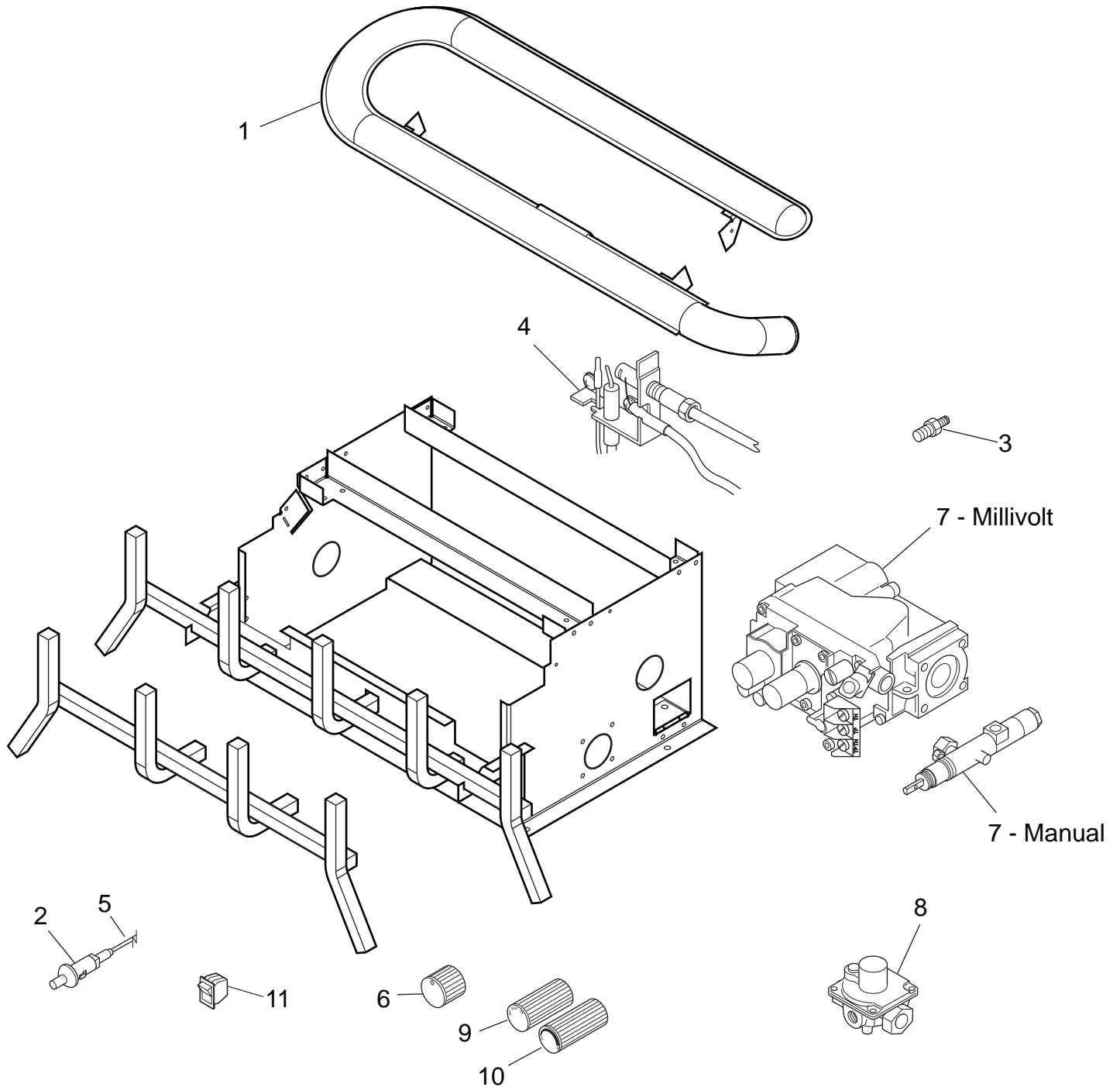

REPLACEMENT PARTS LIST

REPLACEMENT PARTS ARE AVAILABLE THROUGH YOUR RETAILER.

Item	Description	Qty	EYF18		EYF24	
			Natural	Propane	Natural	Propane
Common Parts						
1	Burner	1	65D1053	65D1054	65D1055	65D1056
2	Piezo Ignitor	1	14D0503	14D0503	14D0503	14D0503
Manual Control						
3	Injector	1	58D0051	20H3144	70D0064	57D0612
4	ODS Pilot Assembly	1	26D2529	14D0476	26D2529	14D0476
5	Piezo Wire	1	00K0632	00K0632	00K0632	00K0632
6	Knob Control	1	18D0603	18D0603	18D0603	18D0603
7	Control Valve	1	30D0201	30D0202	30D0201	30D0202
8	Regulator	1	24D0305	24D0306	24D0305	24D0306
Manual Control Parts Not Shown						
	Regulator to Valve Tube	1	65D1004	65D1004	65D1004	65D1004
	Valve to Burner Tube	1	65D1005	65D1005	65D1006	65D1006
	Pilot Tube	1	49D0050	49D0050	49D0050	49D0050
	Pilot Regulator	1	14D0469	—	14D0469	—
Millivolt Control						
3	Injector	1	58D0051	20H3144	57D0209	57D0612
4	ODS Pilot Assembly	1	14D0473	14D0477	14D0473	14D0477
5	Piezo Wire	1	00K0632	00K0632	00K0632	00K0632
7	Control Valve	1	14D0467	14D0468	14D0467	14D0468
9	Knob Extension - On/Off	1	37D0010	37D0010	37D0010	37D0010
10	Knob Extension - Hi/Lo	1	37D0011	37D0011	37D0011	37D0011
11	On/Off Switch	1	32D0232	32D0232	32D0232	32D0232
Millivolt Control Parts Not Shown						
	Valve to Burner Tube	1	65D1007	65D1007	65D1008	65D1008
	Pilot Tube	1	49D0050	49D0050	49D0050	49D0050
	Pilot Regulator	1	14D0469	—	14D0469	—

Accessories			
	Flex Connector	Flexcon 30	All Models
	Wall Switch Kit	MVWS	Millivolt only
	Wall Thermostat Kit	MVWTS	Millivolt only
	Hand Held Remote	RCMT, RCB	Millivolt only
	Hand Held Thermostat Remote	RCT	Millivolt only

ILLUSTRATED PARTS BREAKDOWN

EYF24-F

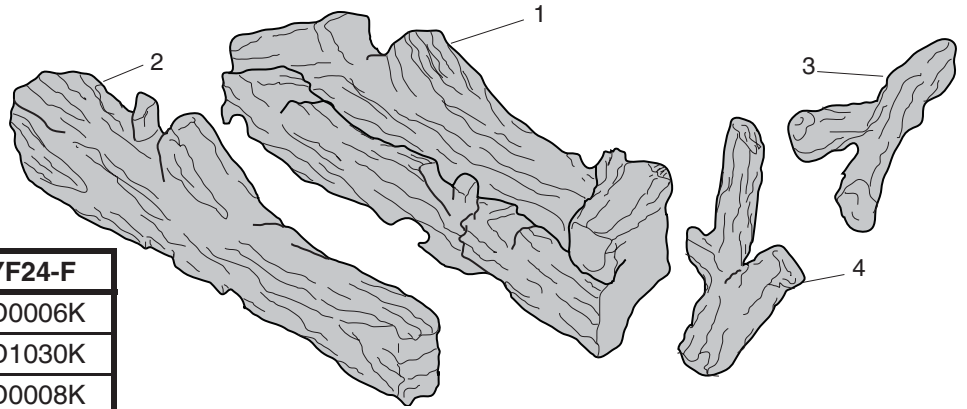

Item	Description	Qty.	EYF24-F
1	Main Log	1	65D0006K
2	Front Log	1	65D1030K
3	Top Left Log	1	65D0008K
4	Top Right Log	1	65D0009K

EYF18-R

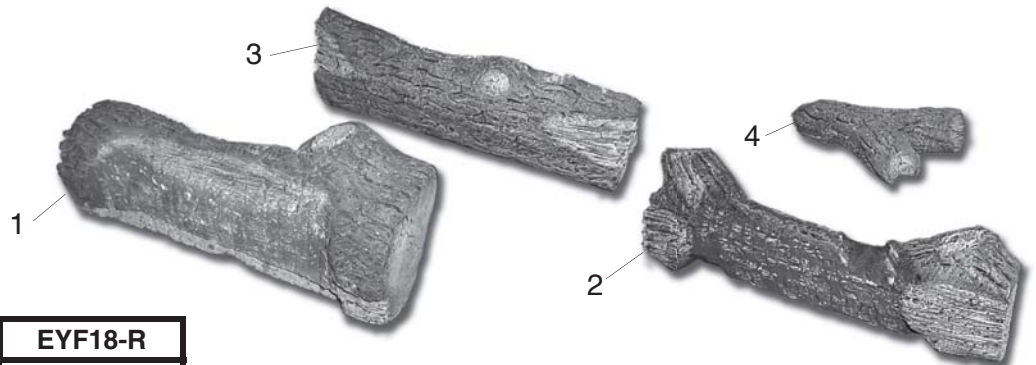

Item	Description	Qty.	EYF18-R
1	Rear Log	1	65D1036K
2	Middle Log	1	65D1037K
3	Front Log	1	65D1038K
4	Top Log	1	65D1039K

EYF24-R & EYF30-R

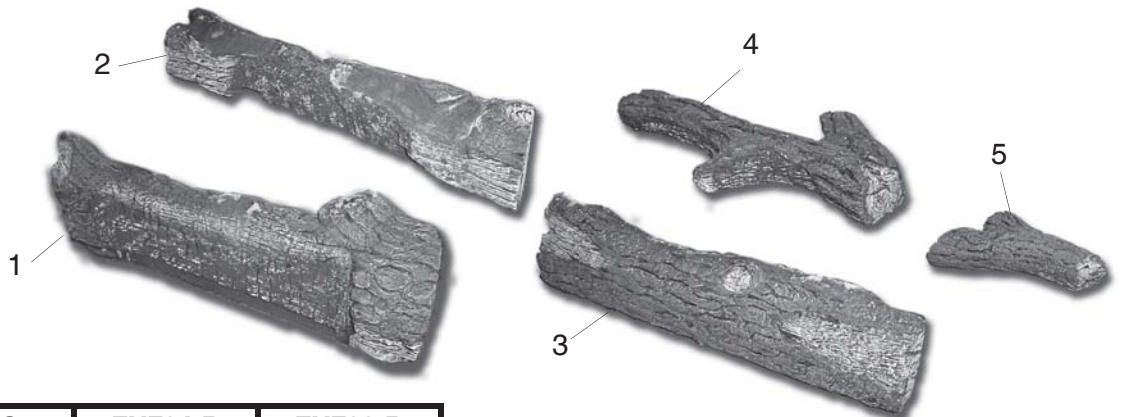

Item	Description	Qty.	EYF24-R	EYF30-R
1	Rear Log	1	65D1031K	65D1031K
2	Middle Log	1	65D1032K	65D1500K
3	Front Log	1	65D1033K	65D1501K
4	Top Right Log	1	65D1034K	65D1034K
5	Top Left Log	1	65D1035K	65D1035K

Massachusetts Residents Only — Please read and follow these special requirements

NOTE REGARDING VENTED PRODUCTS

This product must be installed by a licensed plumber or gas fitter when installed within the Commonwealth of Massachusetts.

Any residence with a direct vent product must have a CO detector installed in the residence.

Installation of the fireplace or vented gas log in the State of Massachusetts requires the damper to be permanently removed or welded in the fully open position.

In addition, a naturally vented gas log may not be installed in a bedroom or bathroom in the State of Massachusetts.

Flex line installation must not exceed 36 inches and must have a T shutoff valve.

NOTE REGARDING VENT FREE PRODUCTS

This product must be installed by a licensed plumber or gas fitter when installed within the Commonwealth of Massachusetts.

In addition, vent free products may not be installed in a bedroom or bathroom regardless of size or type in the State of Massachusetts.

Flex line installation must not exceed 36 inches and must have a T shutoff valve.

CARBON MONOXIDE DETECTOR REQUIREMENTS

(2) Revise 10.8.3 by adding the following additional requirements:

(a) For all side wall horizontally vented gas fueled equipment installed in every dwelling, building or structure used in whole or in part for residential purposes, including those owned or operated by the Commonwealth and where the side wall exhaust vent termination is less than seven (7) feet above finished grade in the area of the venting, including but not limited to decks and porches, the following requirements shall be satisfied:

1. **Installation of carbon monoxide detectors.** At the time of installation of the side wall horizontal vented gas fueled equipment, the installing plumber or gas fitter shall observe that a hard wired carbon monoxide detector with an alarm and battery back-up is installed on the floor level where the gas equipment is to be installed. In addition, the installing plumber or gas fitter shall observe that a battery operated or hard wired carbon monoxide detector with an alarm is installed on each additional level of the dwelling, building or structure served by the side wall horizontal vented gas fueled equipment. It shall be the responsibility of the property owner to secure the services of qualified licensed professionals for the installation of hard wired carbon monoxide detectors

a. In the event that the side wall horizontally vented gas fueled equipment is installed in a crawl space or an attic, the hard wired carbon monoxide detector with alarm and battery back-up may be installed on the next adjacent floor level.

b. In the event that the requirements of this subdivision can not be met at the time of completion of installation, the owner shall have a period of thirty (30) days to comply with the above requirements; provided, however, that during said thirty (30) day period, a battery operated carbon monoxide detector with an alarm shall be installed.

2. **Approved Carbon Monoxide Detectors.** Each carbon monoxide detector as required in accordance with the above provisions shall comply with NFPA 720 and be ANSI/UL 2034 listed and IAS certified.

3. **Signage.** A metal or plastic identification plate shall be permanently mounted to the exterior of the building at a minimum height of eight (8) feet above grade directly in line with the exhaust vent terminal for the horizontally vented gas fueled heating appliance or equipment. The sign shall read, in print size no less than one-half (1/2) inch in size, "GAS VENT DIRECTLY BELOW. KEEP CLEAR OF ALL OBSTRUCTIONS."

4. **Inspection.** The state or local gas inspector of the side wall horizontally vented gas fueled equipment shall not approve the installation unless, upon inspection, the inspector observes carbon monoxide detectors and signage installed in accordance with the provisions of 248 CMR 5.08(2)(a)1 through 4.

(b) **Exemptions:** The following equipment is exempt from 248 CMR 5.08(2)(a)1 through 4:

1. The equipment listed in Chapter 10 entitled "Equipment Not Required To Be Vented" in the most current edition of NFPA 54 as adopted by the Board; and

2. Product Approved side wall horizontally vented gas fueled equipment installed in a room or structure separate from the dwelling, building or structure used in whole or in part for residential purposes.

(c) **Manufacturer requirements — Gas Equipment Venting System Provided.** When the manufacturer of Product Approved side wall horizontally vented gas equipment provides a venting system design or venting system components with the equipment, the instructions provided by the manufacturer for installation of the equipment and the venting system shall include:

1. Detailed instructions for the installation of the venting system design or the venting system components; and

2. A complete parts list for the venting system design or venting system.

(d) **Manufacturer requirements — Gas Equipment Venting System Not Provided.** When the manufacturer of a Product Approved side wall horizontally vented gas fueled equipment does not provide the parts for venting the flue gases, but identifies "special venting systems," the following requirements shall be satisfied by the manufacturer:

1. The referenced "special venting system" instructions shall be included with the appliance or equipment installation instructions; and

2. The "special venting systems" shall be Product Approved by the Board, and the instructions for that system shall include a parts list and detailed installation instructions.

(e) A copy of all installation instructions for all Product Approved side wall horizontally vented gas fueled equipment, all venting instructions, all parts lists for venting instructions, and/or all venting design

MONESSEN HEARTH SYSTEMS CO.

LIMITED LIFETIME WARRANTY POLICY

LIFETIME WARRANTY

The following components are warranted for life to the original owner, subject of proof of purchase: Chassis, Grate and Stainless Steel Burners.

FIVE YEAR WARRANTY

The following components are warranted for 5 years to the original owner, subject of proof of purchase: Refractory Cement and Ceramic Fiber Logs.

BASIC WARRANTY

MHS warrants the components and materials in your gas appliance to be free from manufacturing and material defects for a period of two years from date of installation. After installation, if any of the components manufactured by MHS in the appliance are found to be defective in materials or workmanship, MHS will, at its option, replace or repair the defective components at no charge to the original owner. MHS will also pay for reasonable labor costs incurred in replacing or repairing such components for a period of two years from the date of installation. Any products presented for warranty repair must be accompanied by a dated proof of purchase.

This Limited Lifetime Warranty will be void if the appliance is not installed by a qualified installer in accordance with the installation instructions. The Limited Lifetime Warranty will also be void if the appliance is not operated and maintained according to the operating instructions supplied with the appliance, and does not extend to (1) firebox/burner assembly damage by accident, neglect, misuse, abuse, alteration, negligence of others, including the installation thereof by unqualified installers, (2) the costs of removal, reinstallation or transportation of defective parts on the appliance, or (3) incidental or consequential damage. All service work must be performed by an authorized service representative.

This warranty is expressly in lieu of other warranties, express or implied, including the warranty of merchantability of fitness for purpose and of all other obligations or liabilities. MHS, Inc. does not assume for it any other obligations or liability in connection with the sale or use of the appliance. In states that do not allow limitations on how long an implied warranty lasts, or do not allow exclusion of indirect damage, those limitations of exclusions may not apply to you. You may also have additional rights not covered in this Limited Lifetime Warranty.

MHS reserves the right to investigate any and all claims against the Limited Lifetime Warranty and decide upon method of settlement.

For information about this warranty, contact:

Technical Services
MHSC
149 Cleveland Drive
Paris, Kentucky 40361