

SDV SERIES

DIRECT VENT GAS FIREPLACE

INSTALLATION AND OPERATING INSTRUCTIONS



MODELS:
SDV500 and SDV600

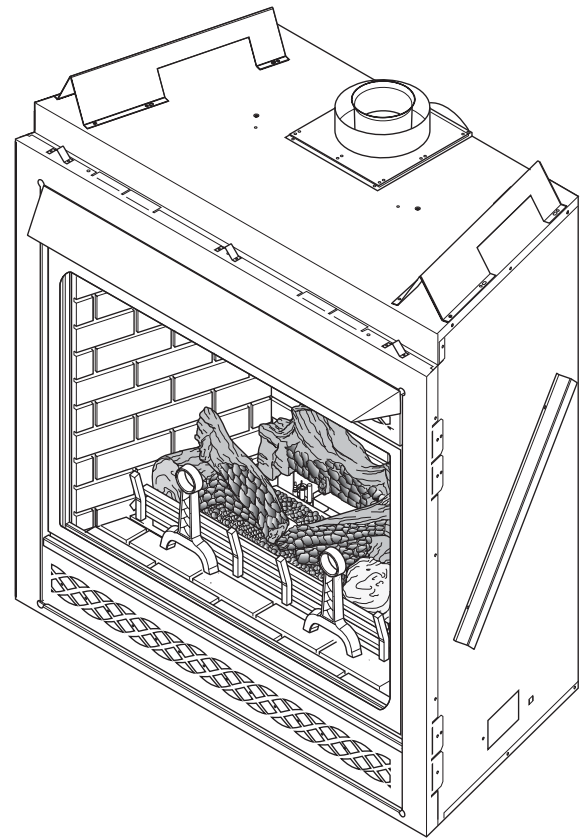

WARNINGS

IF THE INFORMATION IN THESE INSTRUCTIONS ARE NOT FOLLOWED EXACTLY, A FIRE OR EXPLOSION MAY RESULT CAUSING PROPERTY DAMAGE, PERSONAL INJURY OR LOSS OF LIFE.

- Do not store or use gasoline or other flammable vapors and liquids in the vicinity of this or any other appliance.
- **WHAT TO DO IF YOU SMELL GAS**
 - Do not try to light any appliance.
 - Do not touch any electrical switch; do not use any phone in your building.
 - Immediately call your gas supplier from a neighbor's phone. Follow the gas supplier's instructions.
 - If you cannot reach your gas supplier, call the fire department.
- Installation and service must be performed by a qualified installer, service agency or the gas supplier.

WARNING: Improper installation, adjustment, alteration, services or maintenance can cause injury or property damage. Refer to this manual. For assistance or additional information consult a qualified installer, service agency or the gas supplier.

This appliance may be installed in an aftermarket*, permanently located, manufactured home (USA only) or mobile home, where not prohibited by local codes.

This appliance is only for use with the type of gas indicated on the rating plate. This appliance is not convertible for use with other gases, unless a certified kit is used.

* Aftermarket: Completion of sale, not for purpose of resale, from the manufacturer.

DUE TO HIGH TEMPERATURES, THE APPLIANCE SHOULD BE LOCATED OUT OF TRAFFIC AND AWAY FROM FURNITURE AND DRAPERIES.

CHILDREN AND ADULTS SHOULD BE ALERTED TO THE HAZARDS OF HIGH SURFACE TEMPERATURE AND SHOULD STAY AWAY TO AVOID BURNS OR CLOTHING IGNITION.

YOUNG CHILDREN SHOULD BE SUPERVISED WHEN THEY ARE IN THE SAME ROOM AS THE APPLIANCE.

CLOTHING OR OTHER FLAMMABLE MATERIAL SHOULD NOT BE PLACED ON OR NEAR THE APPLIANCE.

KEEP THE ROOM AREA CLEAR AND FREE FROM COMBUSTIBLE MATERIALS, GASOLINE, AND OTHER FLAMMABLE VAPORS AND LIQUIDS.

CONTENTS

Thank you and congratulations on your purchase of a Monessen Hearth Systems Fireplace.

PLEASE READ THE INSTALLATION AND OPERATION INSTRUCTIONS BEFORE USING THE APPLIANCE!

IMPORTANT: Read all instructions and warnings carefully before starting installation.

Failure to follow these instructions may result in a possible fire hazard and will void the warranty.

Important Safety Information	3	Electrical Installation	31
Product Features	5	Electrical Wiring	31
Code Approval	5	Remote Wall Mounted Switch	31
Pre-Installation Information		Electronic Pilot Ignition Wiring	32
Installing Above 2000 Feet.....	6	Canopy Installation	33
Orifice Sizes, Pressures and BTUs.....	6	Glass Removal.....	35
Before You Install	6	Rockwool Placement	35
Fireplace Framing	7	Lava Rock and Embers Placement.....	35
Fireplace Dimensions	8	Andiron Installation	36
Fireplace Location.....	10	Log Placement.....	37
Clearances	11	Operating Instructions	39
Securing Fireplace to Floor or Framing	12	What To Do If You Smell Gas.....	39
Installation Information.....	13	Lighting Pilot for the First Time	39
Vent Installation	13	Lighting Pilot	40
Installation Precautions	13	Lighting Burner.....	40
Optional Top Vent Application	15	Lighting electronic IGN.....	41
Installation Planning.....	16	To Turn Off Gas.....	41
Installation for Vertical Termination	16	Cleaning and Maintenance	42
Rear Wall Vent Installation	19	Burner, Pilot and Control Compartment	42
Horizontal (Through the Wall) Termination Configurations.....	21	Burner Flame	42
Below Grade Installation	23	Vent System.....	43
Vertical Through-the-Roof Installation.....	24	Glass Door	43
Installation for Vertical Termination	26	Logs	43
Flat Ceiling Installation	26	Rock Wool	43
Fireplace Installation.....	28	Replacement Parts	45
Check Gas Type.....	28	Vent Components	45
Installing Gas Piping to Fireplace/Burner		Firebox Components.....	46
System Location	28	Logs	47
Checking Gas Pressure	30	Additional Accessories	48
		Standing Pilot - Millivolt Control	50
		Electronic Ignition.....	52
		Troubleshooting	54
		Warranty	Back Cover

IMPORTANT SAFETY INFORMATION

INSTALLER

Please leave these instructions with the owner.

OWNER

Please retain these instructions for future reference.

WARNING

- **Read this owner's manual carefully and completely before trying to assemble, operate, or service this fireplace.**
- **Any change to this fireplace or its controls can be dangerous.**
- **Improper installation or use of this fireplace can cause serious injury or death from fire, burns, explosions, electrical shock and carbon monoxide poisoning.**

This fireplace is a vented product. This fireplace must be properly installed by a qualified service person. The glass door must be properly seated and sealed. If this unit is not properly installed by a qualified service person with glass door properly seated and sealed, combustion leakage can occur.

CARBON MONOXIDE POISONING: Early signs of carbon monoxide poisoning are similar to the flu with headaches, dizziness and/or nausea. If you have these signs, the fireplace may not have been installed properly. Get fresh air at once! Have the fireplace inspected and serviced by a qualified service person. Some people are more affected by carbon monoxide than others. These include pregnant women, people with heart or lung disease or anemia, those under the influence of alcohol, and those at high altitudes.

Propane/LP gas and natural gas are both odorless. An odor-making agent is added to each of these gases. The odor helps you detect a gas leak. However, the odor added to these gases can fade. Gas may be present even though no odor exists.

Make certain you read and understand all warnings. Keep this manual for reference. It is your guide to safe and proper operation of this fireplace.

1. This appliance is only for use with the type of gas indicated on the rating plate. This appliance is not convertible for use with other gases unless a certified kit is used.
2. For propane/LP fireplace, do not place propane/LP supply tank(s) inside any structure. Locate propane/LP supply tank(s) outdoors. To prevent performance problems, do not use propane/LP fuel tank of less than 100 lbs. capacity.
3. If you smell gas
 - shut off gas supply.
 - do not try to light any appliance.
 - do not touch any electrical switch; do not use any phone in your building .
 - immediately call your gas supplier from a neighbor's phone. Follow the gas supplier's instructions.
4. Never install the fireplace
 - in a recreational vehicle
 - where curtains, furniture, clothing, or other flammable objects are less than 42" from the front, top, or sides of the fireplace
 - in high traffic areas
 - in windy or drafty areas
5. This fireplace reaches high temperatures. Keep children and adults away from hot surfaces to avoid burns or clothing ignition. Fireplace will remain hot for a time after shutdown. Allow surfaces to cool before touching.
6. Carefully supervise young children when they are in the room with fireplace.
7. Do not modify fireplace under any circumstances. Any parts removed for servicing must be replaced prior to operating fireplace.
8. Turn fireplace off and let cool before servicing, installing, or repairing. Only a qualified service person should install, service, or repair the fireplace. Have burner system inspected annually by a qualified service person.
9. You must keep control compartments, burners, and circulating air passages clean. More frequent cleaning may be needed due to excessive lint and dust from carpeting, bedding material, pet hair, etc. Turn off the gas valve and pilot light before cleaning fireplace.
10. Have venting system inspected annually by a qualified service person. If needed, have venting system cleaned or repaired. See *Cleaning and Maintenance*, page 32.
11. Keep the area around your fireplace clear of combustible materials, gasoline, and other flammable vapor and liquids. Do not run fireplace where these are used or stored. Do not place items such as clothing or decorations on or around fireplace.

Continued on page 4

IMPORTANT SAFETY INFORMATION

Continued from page 3

12. Do not use this fireplace to cook food or burn paper or other objects.
13. Never place anything on top of fireplace.
14. Do not use any solid fuels (wood, coal, paper, cardboard, etc.) in this fireplace. Use only the gas type indicated on rating plate.
15. This appliance, when installed, must be electrically grounded in accordance with local codes or in the absence of local codes, with the *National Electrical Code, ANSI/NFPA 70*, or the *Canadian Electrical Code, CSA C22.1*.
16. Do not obstruct the flow of combustion and ventilation air in any way. Provide adequate clearances around air openings into the combustion chamber along with adequate accessibility clearance for servicing and proper operation.
17. When the appliance is installed directly on carpeting, tile or other combustible material other than wood flooring, you must set appliance on a metal or wood panel or hearth pad extending the full width and depth of the appliance.
18. Do not use fireplace if any part has been exposed to or has been under water. Immediately call a qualified service person to arrange for replacement of the unit.
19. Do not operate fireplace if any log is broken.
20. Do not use a blower insert, heat exchanger insert, or any other accessory not approved for use with this fireplace.
21. Do not operate the fireplace with glass door removed, cracked, or broken.
22. **For Massachusetts Residents Only:** This product must be installed by a licensed plumber or gas fitter when installed within the Commonwealth of Massachusetts. Flexline installation must not exceed 36".

IMPORTANT:

PLEASE READ THE FOLLOWING CAREFULLY

It is normal for fireplaces fabricated of steel to give off some expansion and/or contraction noises during the start up or cool down cycle. Similar noises are found with your furnace heat exchanger or car engine.

IMPORTANT:

PLEASE READ THE FOLLOWING CAREFULLY

It is not unusual for gas fireplace to give off some odor the first time it is burned. This is due to the manufacturing process.

Please ensure that your room is well ventilated during burn off — open all windows.

It is recommended that you burn your fireplace for at least ten (10) hours the first time you use it. Place the fan switch in the "OFF" position during this time.



We suggest that our gas hearth products be installed and serviced by professionals who are certified in the U.S. by the National Fireplace Institute® (NFI) as Gas Specialists.

WARNING

Never connect unit to private (non-utility) gas wells. This gas is commonly known as wellhead gas.

PRODUCT FEATURES AND CODE APPROVAL

PRODUCT SPECIFICATIONS

- This appliance has been certified for use with either natural or propane gas. See appropriate data plates.
- This appliance is not for use with solid fuels.
- The appliance is approved for bedroom or bedsitting room installations.
- The appliance must be installed in accordance with local codes if any. If none exist use the current installation code. ANSI Z223.1/NFPA 54 in the USA, CAN/CGA B149 in Canada.
- This appliance is mobile home approved.
- The appliance must be properly connected to a venting system.
- The appliance is not approved for closet or recessed installations.

The efficiency rating of this appliance is a product thermal efficiency rating determined under continuous operating conditions and was determined independently of any installed system.

Thermal Efficiency = up to 80%

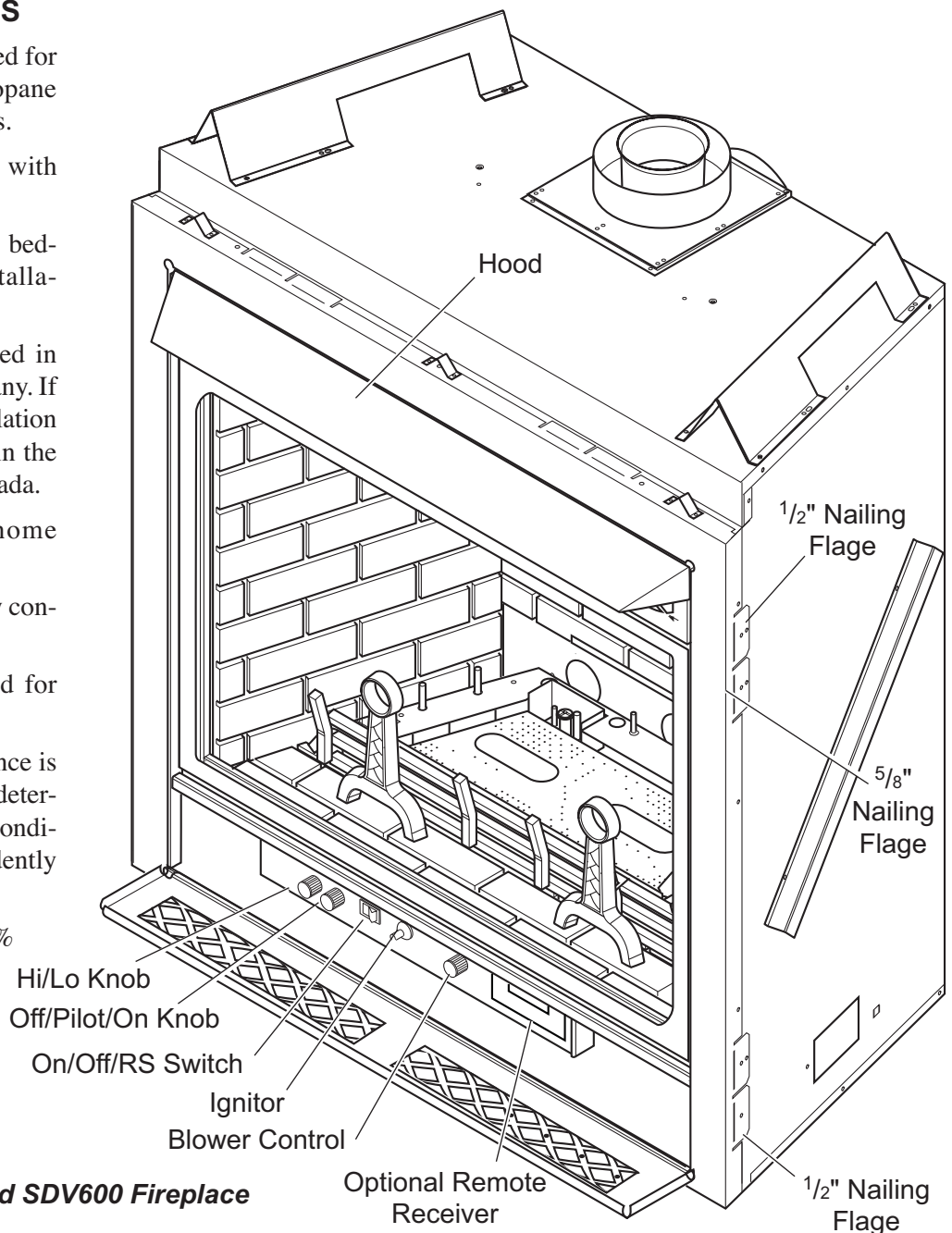

Figure 1 - SDV500 and SDV600 Fireplace

CODE APPROVAL

Direct Vent type appliances draw all combustion air from outside of the dwelling through the vent pipe.

These appliances have been tested by CSA and found to comply with the established standards for DIRECT VENT GAS FIREPLACE HEATERS in the USA and Canada as follows:

LISTED VENTED GAS FIREPLACE HEATER
TESTED TO: ANSI Z21.88-2002/CSA 2.33-2002 STANDARDS

A manufactured home (USA only) or mobile home OEM installation must conform with the *Manufactured Home Construction and Safety Standard, Title 24 CFR, Part 3280*, or when such a standard is not applicable, the *Standard for Manufactured Home Installations, ANSI/NCSBCS A225.1*, or *Standard for Gas Equipped Recreational Vehicles and Mobile Housing, CSA Z240.4*.

PRE-INSTALLATION INFORMATION

INSTALLING ABOVE 2000 FEET

- In the USA, the appliance must be derated 4% for every 1,000 ft above 2,000 ft elevations.
- In Canada, these appliances are certified for altitudes of 0 – 2000 ft, and must be de-rated by 10 percent for installations between 2000 and 4,500 ft. (derate an additional 4% for every 1,000 ft. above 4,500 ft. elevations).

ORIFICE SIZES, PRESSURES AND BTUs

NATURAL GAS

Manifold Press: (W.C.) 3.5"
Maximum Supply Pressure 10.5"
Minimum Supply Pressure 4.5"

PROPANE GAS

Manifold Press: (W.C.) 10"
Maximum Supply Pressure 13"
Minimum Supply Pressure 11"

Model Number	SDV500		SDV600	
	Natural	Propane	Natural	Propane
Max. Btu/hr Input	30,000	30,000	32,000	32,000
Min. Btu/hr Input	22,000	22,000	25,000	25,000
Burner Orifice size (as shipped)	#37	#52	#34	#51

BEFORE YOU START

Read this homeowner manual thoroughly and follow all instructions carefully. Inspect all contents for shipping damage and immediately inform your dealer if any damage is found. Do not install any unit with damaged, incomplete, or substitute parts. Check your packing list to verify that all listed parts have been received. You should have the following:

- Fireplace (Firebox and Burner System)
- White Toggle Switch (1)
- Log Set
- Canopy
- Plastic Bag (1)
- Volcanic Rock
- Switch Cover Plate (1)
- Andirons (2)
- Ziplock Bag 2"x3"x3"
- Rock Wool
- Restrictor Plate/Disc

ITEMS REQUIRED FOR INSTALLATION

Tools:

- Phillips Screwdriver
- Hammer
- Saw and/or saber saw
- Level
- Measuring Tape
- Electric Drill and Bits
- Pliers
- Square
- Pipe Wrench

Building Supplies:

- Framing Materials
- Wall Finishing Materials
- Caulking Material (Noncombustible)
- Fireplace Surround Material (Noncombustible)
- Piping Complying with Local Codes
- Tee Joint
- Pipe Sealant Approved for use with Propane/LPG (Resistant to Sulfur Compounds)

FIREPLACE FRAMING

Firebox framing can be built before or after the appliance is set in place. Construct firebox framing following *Figure 2* and the chart below for your specific installation requirements. See *Figures 3 and 4 on Pages 8 and 9* for firebox dimensions. The framing headers may rest on the top of the firebox standoffs.

The firebox may be installed directly on a combustible floor or raised on a platform of an appropriate height. When the firebox is installed directly on carpeting, tile, or other combustible material, other than wood flooring, the firebox shall be installed on a metal or wood panel extending the full width and depth of the enclosure.

WARNING
Do not fill spaces around firebox with insulation or other materials. This could cause a fire.

	SDV500	SDV600
A	41 ⁹ / ₁₆ "	47 ⁹ / ₁₆ "
B	47 ¹ / ₄ "	47 ¹ / ₄ "
C	30 ⁵ / ₈ "	36 ⁵ / ₈ "
D	21 ¹ / ₂ "	25"
E	64 ¹ / ₂ "	73 ¹ / ₂ "
F	42 ⁵ / ₆₄ "	45 ³ / ₄ "
G	21 ¹³ / ₁₆ "	21 ¹³ / ₁₆ "
H	53"	57 ³ / ₄ "

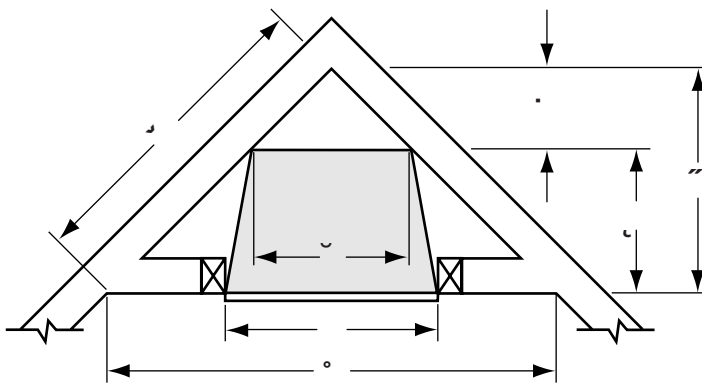

Corner Installation

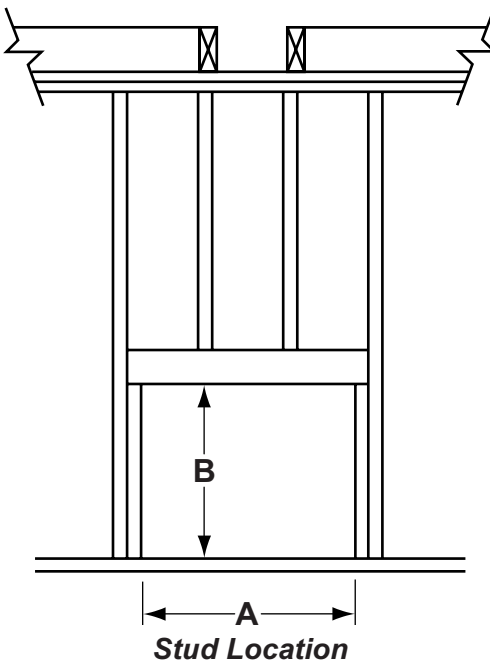

Stud Location

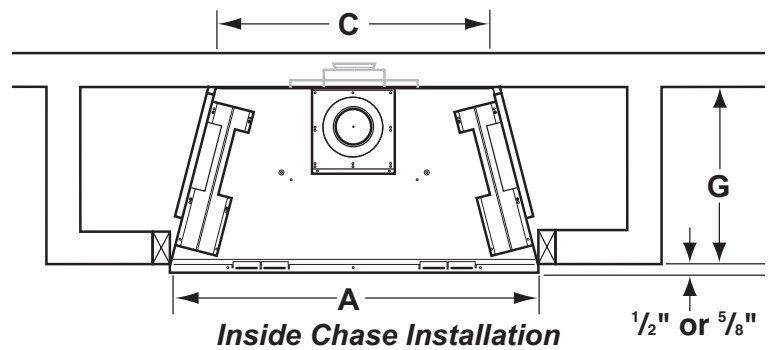

Inside Chase Installation

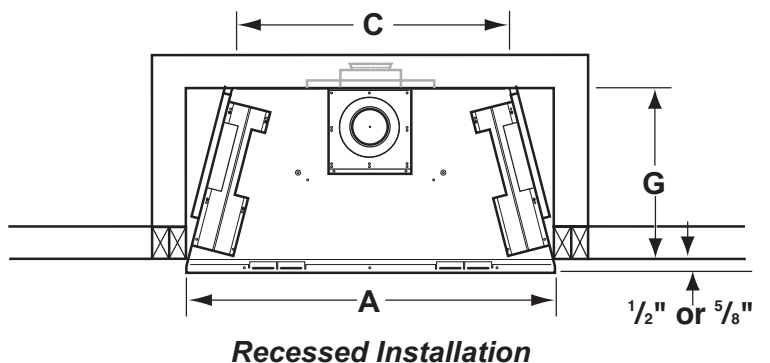

Recessed Installation

Figure 2 - Framing Dimensions

PRE-INSTALLATION INFORMATION

SDV500

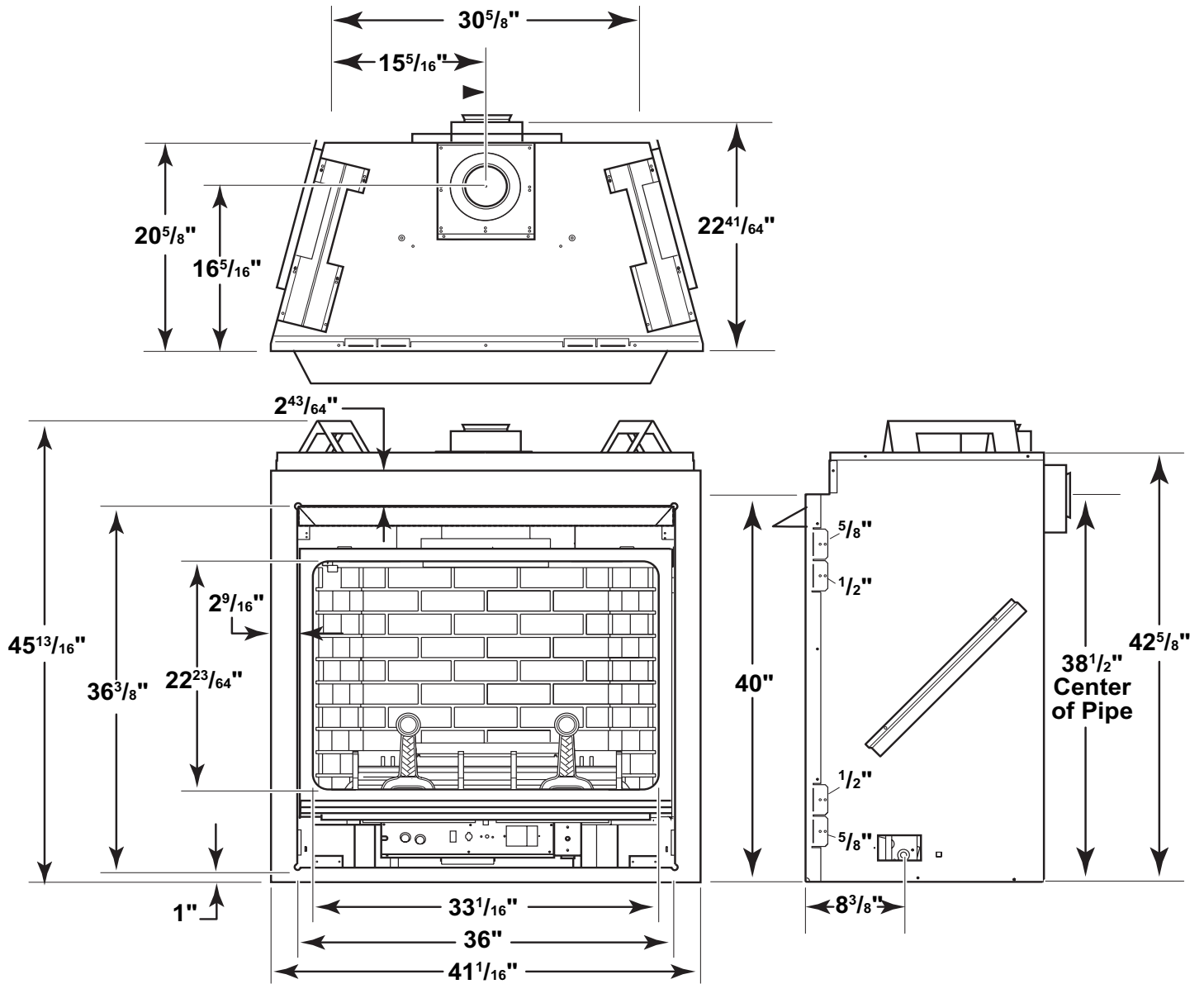

Figure 3 - SDV500 Fireplace Dimensions

SDV600

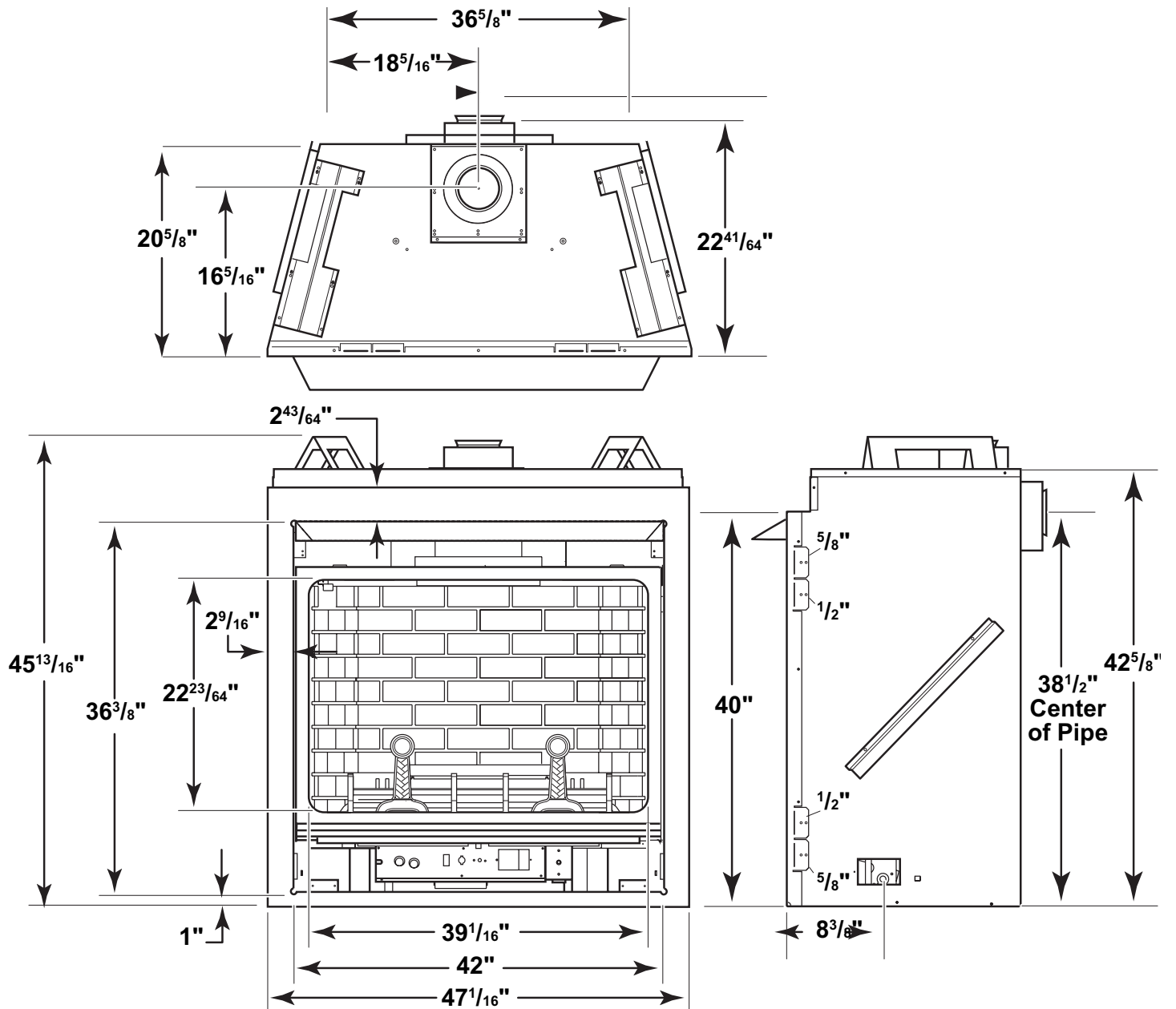

Figure 4 - SDV600 Fireplace Dimensions

PRE-INSTALLATION INFORMATION

FIREPLACE LOCATION

Plan for the installation of your appliance. This includes determining where the unit is to be installed, the vent configuration to be used, framing and finishing details, and whether any optional accessories (i.e. blower, wall switch, or remote control) are desired. Consult your local building code agency to ensure compliance with local codes, including permits and inspections.

The following factors should be taken into consideration:

- Clearance to side-wall, ceiling, woodwork, and windows. Minimum clearances to combustibles **must be maintained**.
- This fireplace may be installed along a wall, across a corner, or use an exterior chase. See *Figure 5* for suggested locations.
- Location should be out of high traffic areas and away from furniture and draperies due to heat from appliance.
- Never obstruct the front opening of the fireplace.
- Do **not** install in the vicinity where gasoline or other flammable liquids may be stored.
- Vent pipe routing. See *Venting* section found in this manual for allowable venting configurations.
- These units can be installed in a bedroom. See National Fuel Gas Code ANSI Z233.1/NFPA 54 — (current edition), the Uniform Mechanical Code — (current edition), and Local Building Codes for specific installation requirements.

A	Flat on Wall
B	Cross Corner
C	Island**
D	Room Divider*
E	Flat on Wall Corner*
F	Chase Installation
Y	4" Minimum

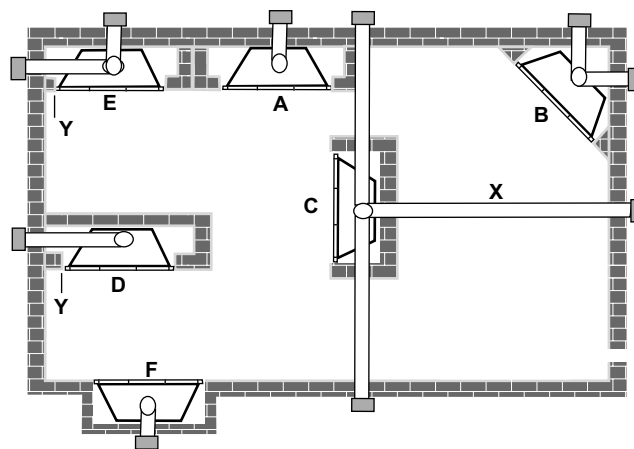

Figure 5 - Locating Gas Fireplace

** Island (C) and room divider (D) installation is possible as long as the horizontal portion of vent system (X) does not exceed 20'. See *Installing Horizontal Termination Configuration* on pages 18 and 19.

* When you install your fireplace in (D) room divider or (E) flat on wall corner positions (Y), a minimum of 4" clearance must be maintained from perpendicular wall and front of fireplace.

SECURING FIREPLACE TO FLOOR OR FRAMING

The fireplace must be secured to the floor and/or to framing studs as shown in *Figure 6*. Use two (2) wood screws or masonry/concrete screws to secure fireplace to the floor. Use four (4) screws to attach fireplace to framing. The side brackets are adjustable from 1/2" to 5/8" to accommodate different thickness of material.

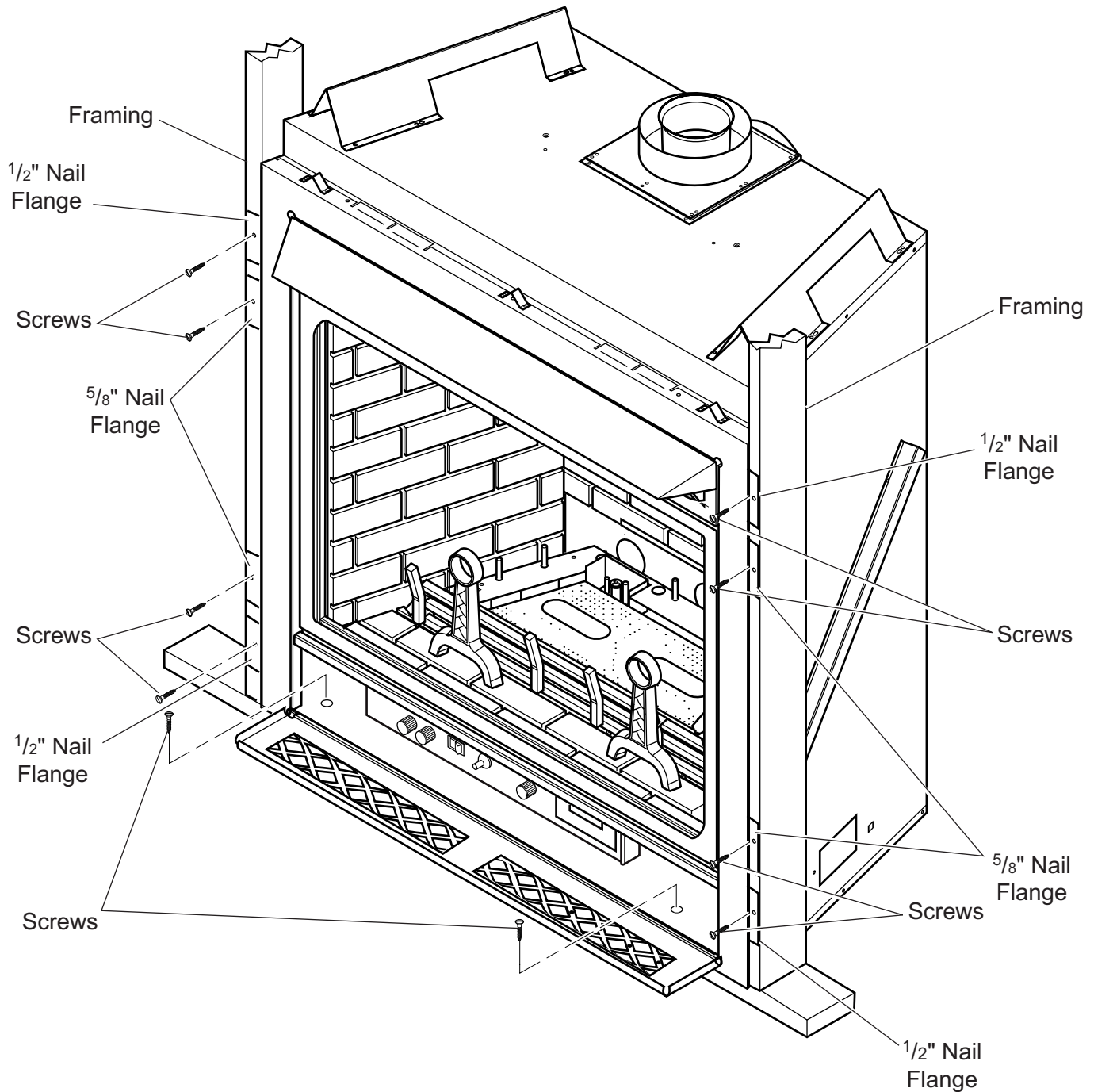

Figure 6 - Securing Fireplace to Floor and Framing Studs

CLEARANCES

CLEARANCES TO COMBUSTIBLES

WARNING

Follow these instructions carefully to ensure safe installation. Failure to follow instructions exactly can create a fire hazard.

The appliance cannot be installed on a carpet, tile or other combustible material other than wood flooring. If installed on carpet or vinyl flooring, the appliance shall be installed on a metal, wood or noncombustible material panel extending full width and depth of the appliance.

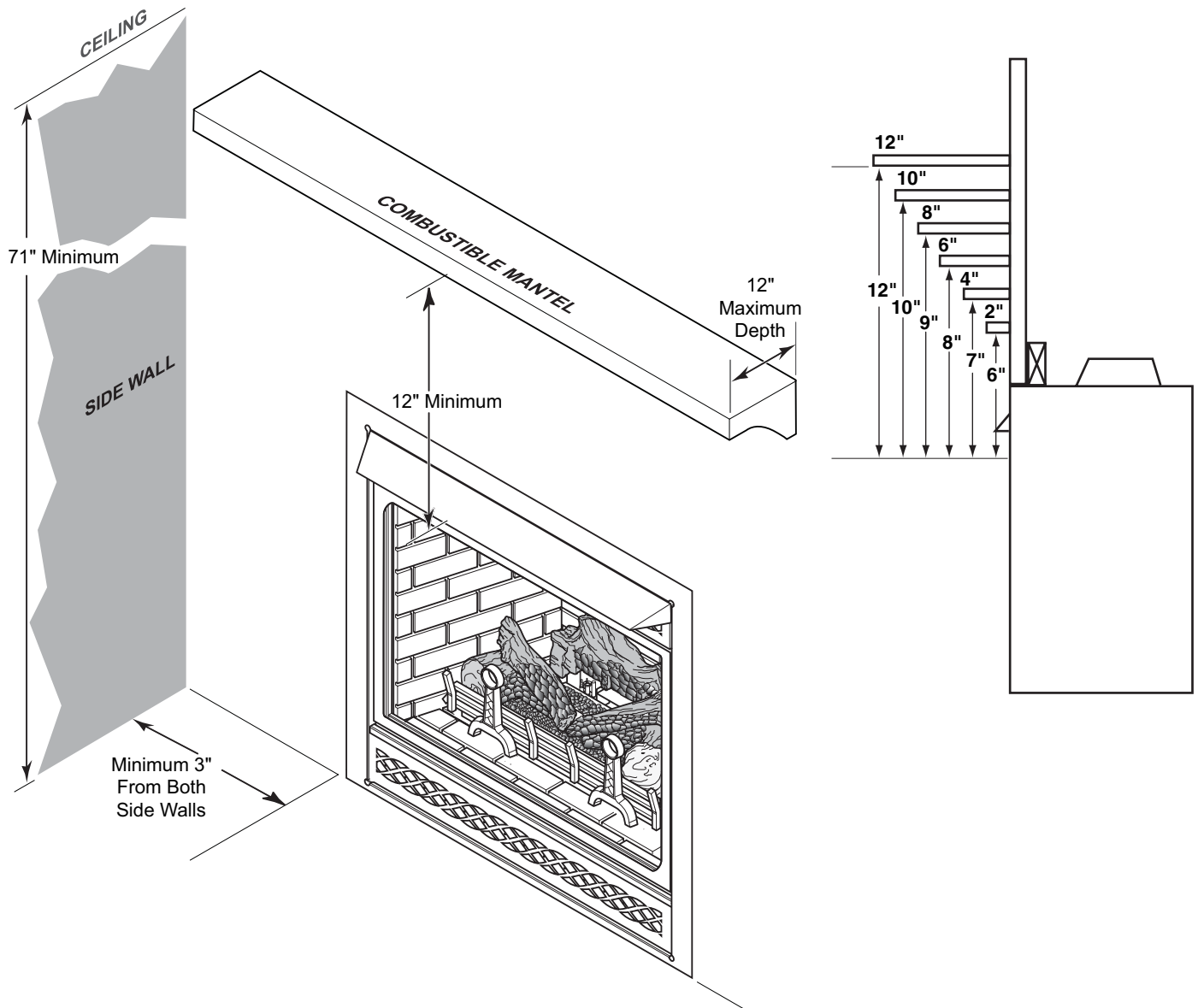

Figure 7 - Clearances

MANTEL CLEARANCES

NOTE: The combustible area around the fireplace must not protrude more than $\frac{1}{2}$ " from the facing. If it does, it is considered a mantel and must meet the mantel requirements listed in this manual.

INSTALLATION INFORMATION

FINISHING MATERIAL

NOTE: Any remote wiring (i.e. remote control, wall switch, and optional fan) must be done prior to final finishing to avoid costly reconstruction.

WARNING Never obstruct or modify the air inlet or outlet grills (louvers). This may create a fire hazard.

Only noncombustible materials (i.e. brick, tile, slate, steel, or other materials with a UL fire rating of Zero) may be used to cover the black surface of the appliance. A 300°F minimum adhesive may be used to attach facing materials to the black surface. If joints between the finished wall and the fireplace surround are sealed, a 300°F minimum sealant material (General Electric RTV103 or equivalent) must be used.

VENT INSTALLATION

WARNING Read all instructions completely and thoroughly before attempting installation. Failure to do so could result in serious injury, property damage or loss of life. Operation of improperly installed and maintained venting system could result in serious injury, property damage or loss of life.

NOTICE Failure to follow these instructions will void the warranty.

INSTALLATION PRECAUTIONS

Consult local building codes before beginning the installation. The installer must make sure to select the proper vent system for installation. Before installing vent kit, the installer must read this fireplace manual and vent kit instructions.

Only a qualified installer/service person should install venting system. The installer must follow these safety rules:

- Wear gloves and safety glasses for protection.
- Use extreme caution when using ladders or when on rooftops.
- Be aware of electrical wiring locations in walls and ceilings.

The following actions will void the warranty on your venting system:

- Installation of any damaged venting component.
 - Unauthorized modification of the venting system.
 - Installation of any component part not manufactured or approved by Monessen Hearth Systems
 - Installation other than permitted by these instructions.
-

VENT INSTALLATION

WARNING

This fireplace must be vented to the outside. The venting system must **NEVER** be attached to a chimney serving a separate solid fuel burning appliance. Each gas appliance must use a separate vent system. Do not use common vent systems.

WARNING

Horizontal sections of this vent system require a minimum of 3" clearances to combustibles at the top of the flue and 1" clearance at the sides and bottom *until the flue penetrates the outside wall*. A minimum 1" clearance all around the flue is acceptable at this point of penetration.

Vertical sections of this vent system require a minimum of 1" clearance to combustibles on all sides of the pipe.

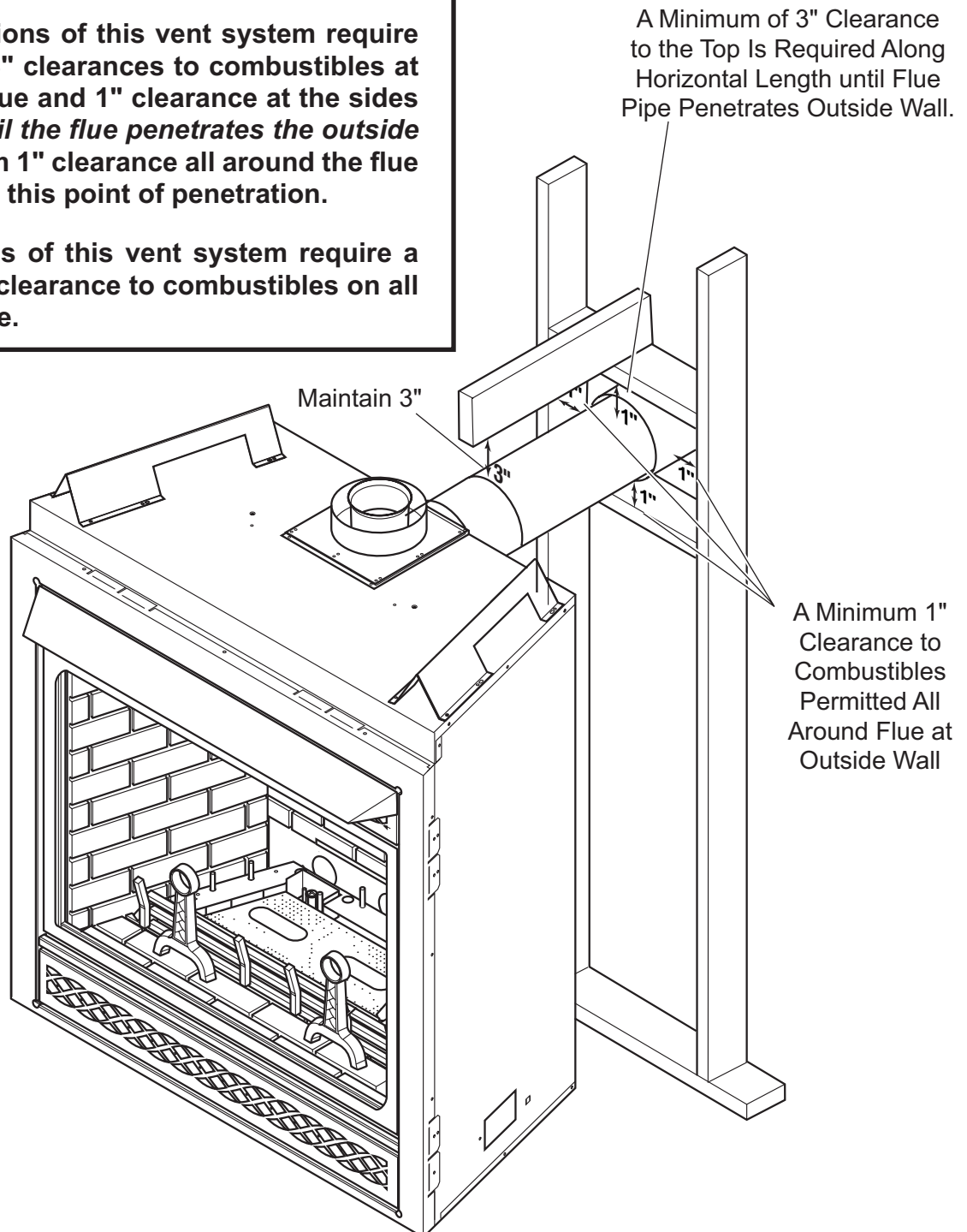

Figure 8 - Combustible Clearances for Vent Pipe

OPTIONAL TOP VENT APPLICATION

The appliance is shipped as a rear vent unit. If the installation layout requires the unit to be a top vent configuration the appliance can be converted by following the steps below.

When removing and refitting the plates and adapter be sure the associated gaskets are undamaged and refitted as required.

1. Remove the eight (8) screws securing the flue pipe adapter to the fireplace body. *See Figure 9.*
2. Set the flue pipe adapter aside, complete with the gasket. Do not damage the gaskets as the adapter and gasket must be refitted.
3. Remove the six (6) screws securing the flue pipe cover to the top of the intake box and remove the cover and gasket. *See Figure 9.*
4. Remove six (6) screws securing the flue pipe to the back of the intake box and remove the pipe and gasket. *See Figure 10.*
5. Replace flue pipe to top of firebox. Ensure the gasket is in place and undamaged. Secure with six (6) screws. *See Figure 10.*
6. Place the flue pipe cover and gasket removed in step 3 over the flue opening in bottom of the intake box.
7. Refit the flue pipe adapter and gasket to the top of fireplace. Secure the adapter with six (6) screws removed in step 1.

WARNING

After conversion to top vent configuration the 4" (100mm) flue pipe should be concentric with the 6⁵/₈" (175mm) outer collar within 1/4".

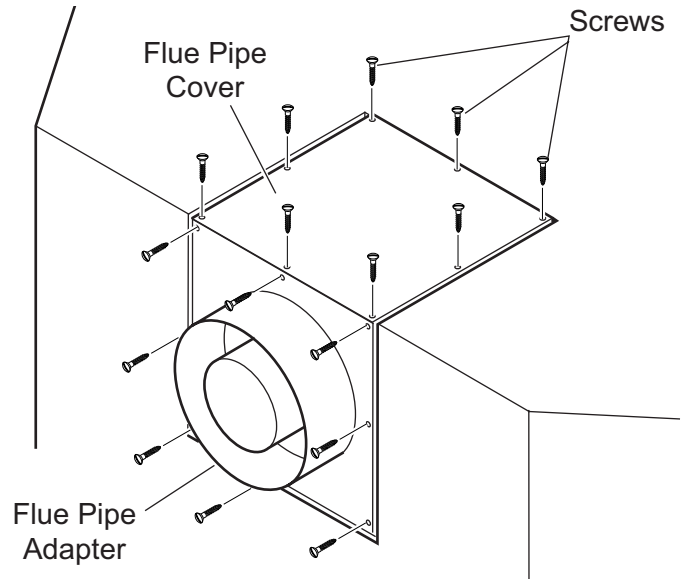

Figure 9 - Removing sixteen (16) Screws from Flue Pipe Adapter and Flue Pipe Cover

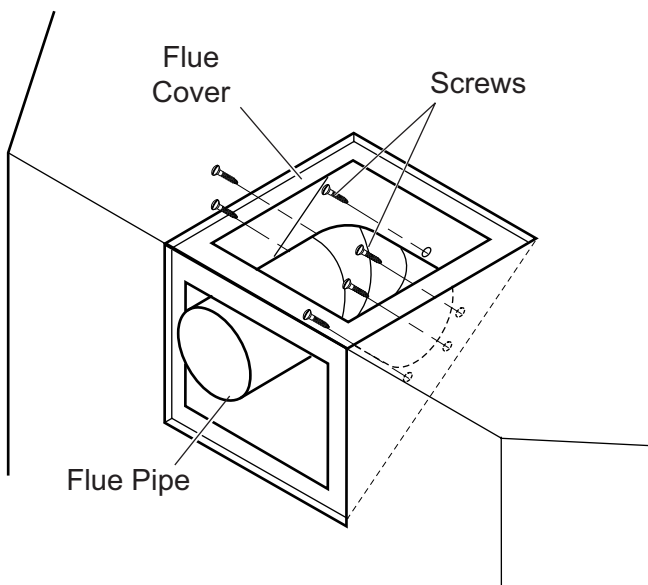

Figure 10 - Removing Flue Pipe

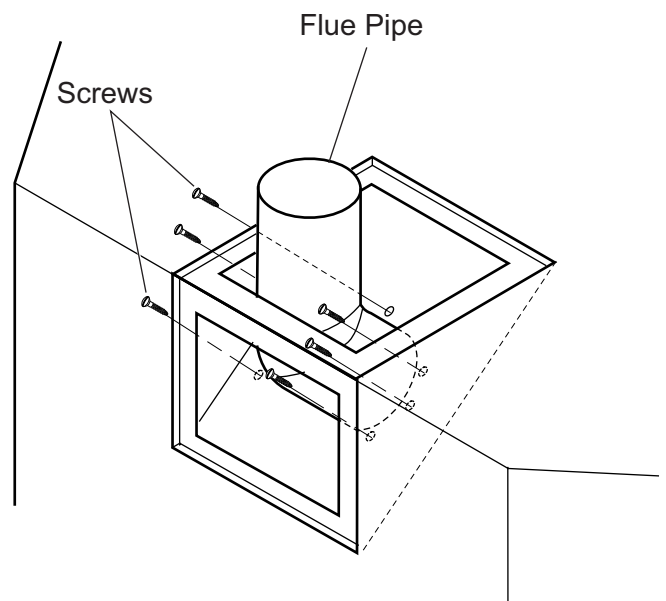

Figure 11 - Attaching Flue Pipe to Top Vent Configurations

VENT INSTALLATION

INSTALLATION PLANNING

There are two basic types of direct-vent installation:

- Horizontal Termination
- Vertical Termination

It is important to select the proper length of vent pipe for the type of termination you choose. It is also important to note the wall thickness.

FOR HORIZONTAL TERMINATION

Select the amount of vertical rise desired. All horizontal run of venting must have $\frac{1}{4}$ " rise for every 12" of run towards the termination.

You may use up to three 90° elbows in this vent configuration. See *Horizontal Termination Configurations* on pages 20 and 21.

WARNING

Never run the vent pipe level or downward. This may cause excessive temperatures which could cause a fire.

FOR VERTICAL TERMINATION

Measure the distance from the fireplace floor to the ceiling. Add the ceiling thickness, the vertical rise in an attic or second story, and allow for sufficient vent height above the roof line.

NOTE: You may use two 45° elbows in place of a 90° elbow. You must follow rise to run ratios when using 45° elbows. The appliance is approved for use with three 90° elbows maximum or a combination of 90° and 45° elbows up to a maximum of 270°.

For two-story applications, firestops are required at each floor level. If an offset is needed in the attic, additional pipe and elbows will be required.

You may use a chase with a vent termination with exposed pipe on the exterior of the house. See *Installing Vent System in a Chase* below. If pipe is enclosed in chase, it is not exposed.

It is very important that the venting system maintain its balance between the combustion air intake and the flue gas exhaust. Certain limitations apply to vent configurations and must be strictly followed.

INSTALLING A VENT SYSTEM IN AN OUTSIDE CHASE

A chase is a vertical boxlike structure built to enclose venting that runs along the outside of a building. A chase is required for such venting.

NOTICE

Treatment of firestops and construction of the chase may vary from building type to building type. These instructions are not substitutes for the requirements of local building codes. You must follow all local building codes.

NOTICE

When installing in a chase, you should insulate the chase as you would the outside walls of your home. This is especially important in cold climates. Insulation should be considered a combustible material. Maintain proper clearances to all combustible materials.

FOR HORIZONTAL TERMINATION

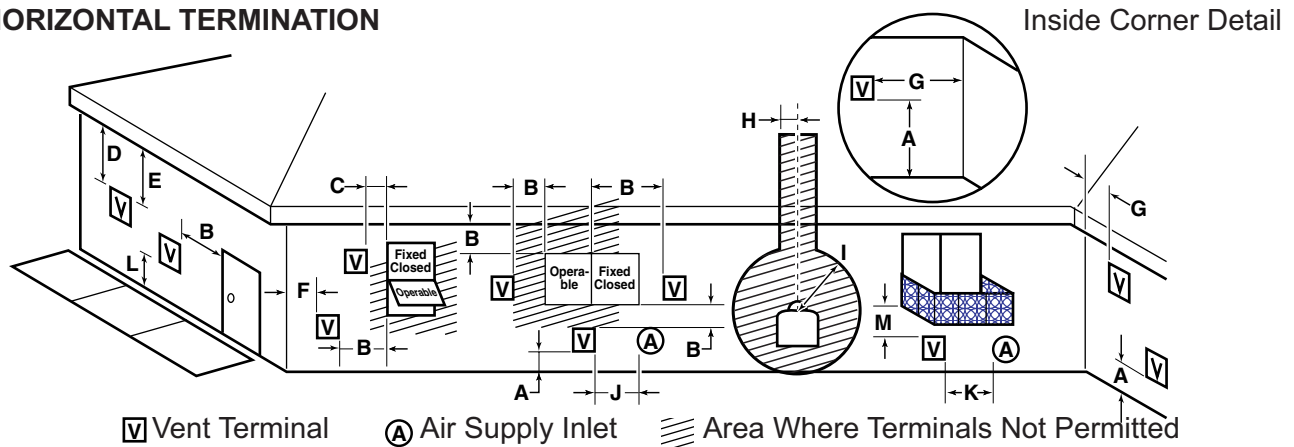

Figure 12 - Horizontal Vent Termination Location

MINIMUM DISTANCES

- A = Clearance above the grade, a veranda, porch, deck, or balcony [*12" (305mm) minimum].
 - B = Clearance to window or door that may be opened [*12" (305mm) minimum].
 - C = Clearance to permanently closed window [*minimum 12" (305mm) recommended to prevent condensation on window]
 - D = Vertical clearance to ventilated soffit located above the terminal within a horizontal distance of two (2) feet (610mm) from the centerline of the terminal [18" (457mm) minimum].
 - E = Clearance to unventilated soffits [12" (305mm) minimum]. **Clearance to vinyl soffit [30" (762mm)].**
 - F = Clearance to an outside corner. See page 12.
 - G = Clearance to an inside corner. See page 12.
 - H = *Not to be installed above a gas meter/regulator assembly within three (3) feet (914mm) horizontally from the centerline of the regulator.
 - I = Clearance to service regulator vent outlet [*3' (914mm) minimum].
 - J = Clearance to non-mechanical air supply inlet to building or the combustion air inlet to any other appliance [*12" (305mm) minimum].
 - K = Clearance to a mechanical air supply inlet [*6' (1829mm) minimum].
 - L = Clearance above a paved sidewalk or paved driveway located on public property [**7' (2133mm) minimum].
 - M = Clearance under veranda, porch, deck, or balcony [*12" (305mm) minimum ***].
 - N = Clearance above a roof shall extend a minimum of 24" (610mm) above the highest point when it passes through the roof surface and any other obstruction within a horizontal distance of 18" (457mm).
- * As specified in CAN/CGA B149 Installation Codes. Note: Local codes or regulations may require different clearances.
- ** A vent must not terminate directly above a sidewalk or paved driveway, which is located between two single-family dwellings and serves both dwellings.
- *** Only permitted if veranda, porch, deck, or balcony is fully open on a minimum of two sides beneath the floor.

WARNING

Always maintain minimum clearances around vent systems. The minimum clearances to combustibles for horizontal vent pipe are 3" at the top and 1" at the sides and bottom of the vent system until the pipe penetrates the outside vertical wall (1" required). A 1" minimum clearance all around the pipe must be maintained. Do not pack the open air spaces with insulation or other materials. This could cause high temperatures and may present a fire hazard.

VENT INSTALLATION

TERMINATION CLEARANCES FOR BUILDINGS WITH COMBUSTIBLE AND NONCOMBUSTIBLE EXTERIORS

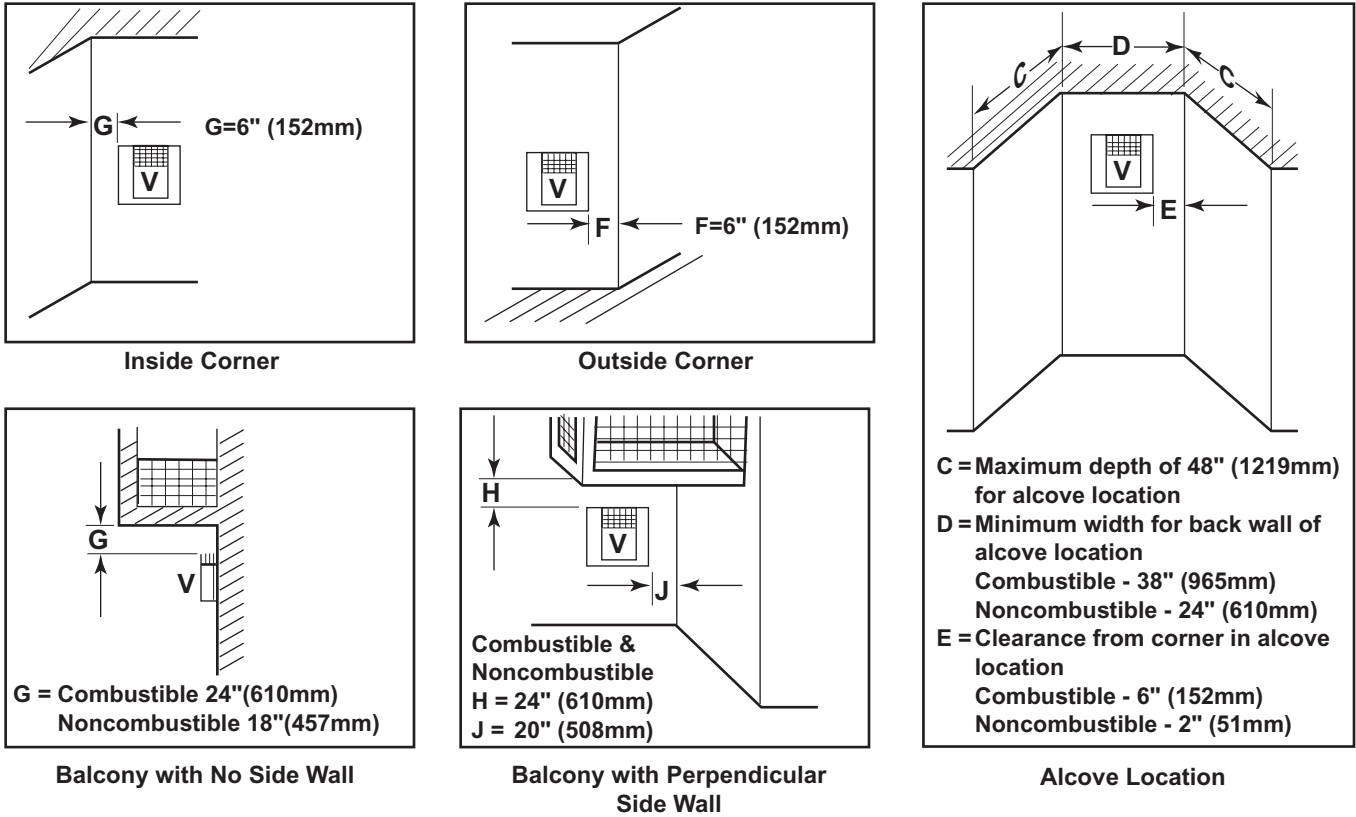

Figure 13 - Allowable Venting Chart

HOW TO USE THE VENT GRAPH

The Vent Graph should be read in conjunction with the following vent installation instructions to determine the relationship between the vertical and horizontal dimensions of the vent system.

1. Determine the height of the center of the horizontal vent pipe exiting through the outer wall. Using this dimension on the Sidewall Vent Graph below, locate the point intersecting with the slanted graph line.
2. From the point of this intersection, draw a vertical line to the bottom of the graph.
3. Select the indicated dimension, and position the fireplace in accordance with same.

Example A: If the vertical dimension from the floor of the fireplace is 11' (3.4m) the horizontal run to the face of the outer wall must not exceed 14' (4.3m).

Example B: If the vertical dimension from the floor of the unit is 7' (2.14m), the horizontal run to the face of the outer wall must not exceed 8 1/2' (2.6m).

Sidewall Vent Graph showing the relationship between vertical and horizontal dimensions for a Direct Vent flue system.

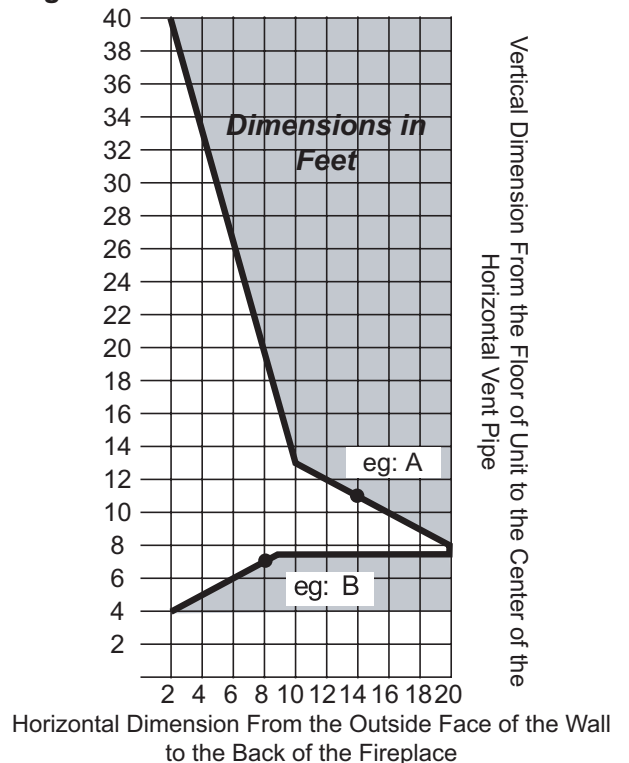
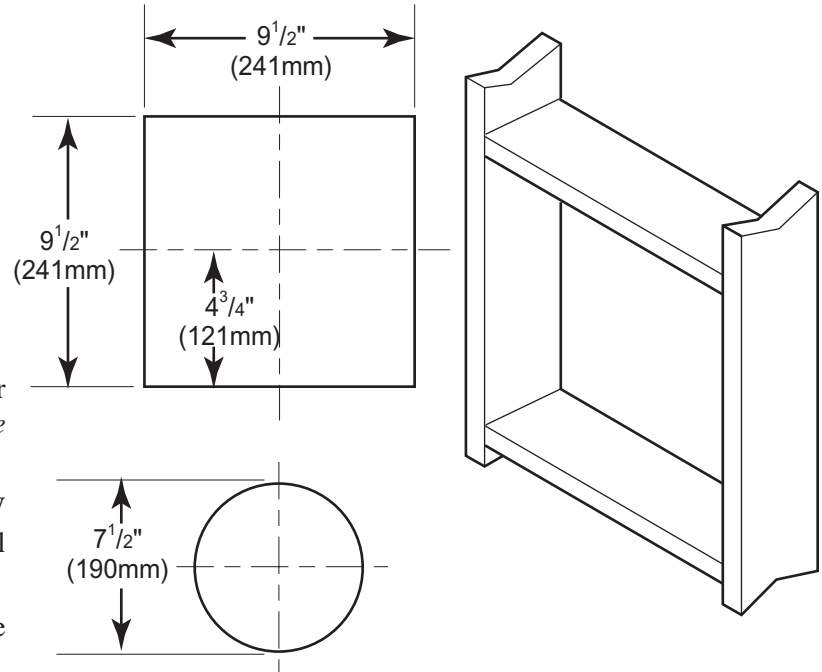
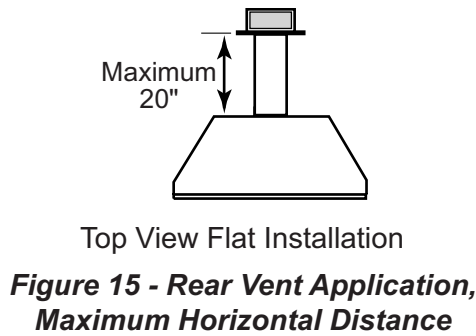

Figure 14 - Rear Wall Venting Graph

REAR WALL VENT INSTALLATION

When installed as a rear vent unit this appliance may be vented directly to a termination located on the rear wall behind the appliance

- The maximum horizontal distance between the rear of the appliance and the outside of termination is 20" (508 m). See *Figure 15*.
- Only one 45° elbow is allowed in these installations.



1. Locate and cut the vent opening in the wall. For combustible walls first frame in opening. See *Figure 16*.

Combustible Walls: Cut a 9¹/₂"H x 9¹/₂" W (241 mm x 241 mm) hole through the exterior wall and frame as shown. See *Figure 16*.

Noncombustible Walls: Hole opening should be 7¹/₂" (190 mm) in diameter.

2. Rigid vent pipes and fittings have special twist-lock connections. Assemble the desired combination of pipe and elbows to the appliance adaptor with pipe seams oriented towards the wall or floor.

Twist-lock Procedure: The female ends of the pipes and fittings have three locking lugs (indentations). These lugs will slide straight into matching slots on the male end of adjacent pipes and fittings. Push the pipe sections together and twist one section clockwise approximately one-quarter turn until the sections are fully locked. See *Figure 17*.

3. Attach vent pipe assembly to the fireplace. Set fireplace in front of its permanent location to insure minimum clearances. Mark the wall for a 9¹/₂"H x 9¹/₂"W (241 mm x 241 mm) rectangle hole (for noncombustible material such as masonry block or concrete, a 7¹/₂" [190 mm] diameter hole is acceptable). See *Figure 16*. The center of the hole should line up with the center line of the horizontal rigid vent pipe end. Be sure to allow for minimum rise.

Cut a 9¹/₂"x9¹/₂" (241 mm X 241 mm) rectangle hole through combustible exterior wall (7¹/₂" [190 mm] diameter hole if noncombustible). Frame as necessary. Allow 1/4" minimum rise per foot. See *Figure 16*.

Figure 16 - Vent Opening Requirements

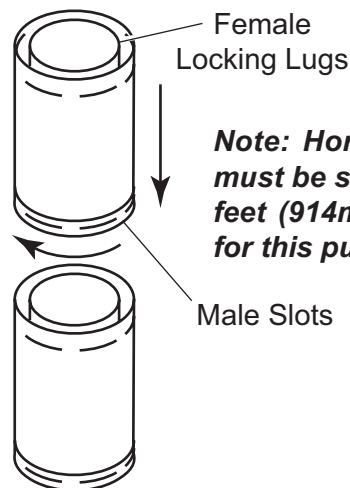

Note: Horizontal runs of vent must be supported every three feet (914 mm). Use wall straps for this purpose.

Figure 17 - Rigid Vent Pipe Connections

VENT INSTALLATION

REAR WALL VENT INSTALLATION (*continued*)

4. Apply a bead of non-hardening mastic around the outside edge of vent cap. Position the vent cap in the center of hole on the exterior wall with the word "UP" on the vent cap facing up. Insure proper clearance of 1" to combustibles is maintained. Attach the vent cap with four wood screws supplied. See Figure 18.

WARNING

Do not recess vent termination into any wall. This will cause a fire hazard.

NOTE: Replace the wood screws with appropriate fasteners for stucco, brick, concrete, or other types of siding.

For vinyl siding, stucco, or wood exterior use vinyl siding standoffs between vent cap and exterior wall. The vinyl siding standoff prevents excessive heat from melting the vinyl siding material. Bolt the vent cap to the standoff. Apply non-hardening mastic around outside edge of the standoff instead of the vent cap assembly. Use wood screws provided to attach the standoff. See Figure 19.

5. Slide the wall thimble over the vent pipe before connecting the horizontal run to the vent cap. See Figure 20.
6. Carefully move the fireplace with vent assembly attached toward the wall and insert the vent pipe into the horizontal termination. The pipe overlap should be a minimum of 1¹/₄". Apply silicone to the outer pipe connection. Fasten all vent connections with screws provided.
7. Slide the wall thimble against the interior wall surface and attach with screws. See Figure 20.

NOTICE

For more information, follow instructions that comes with terminations.

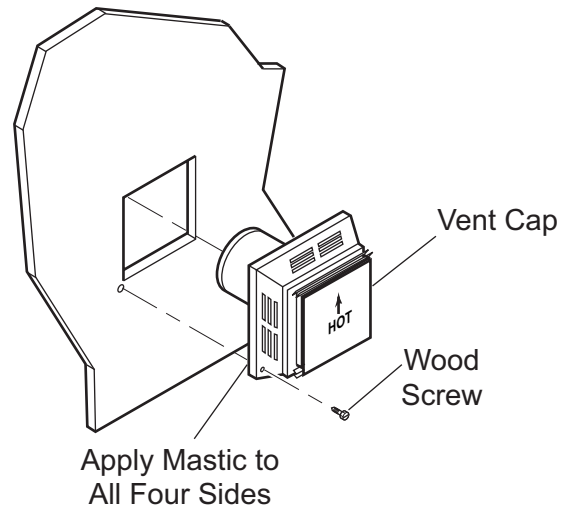

Figure 18 - Installing Horizontal Vent Cap

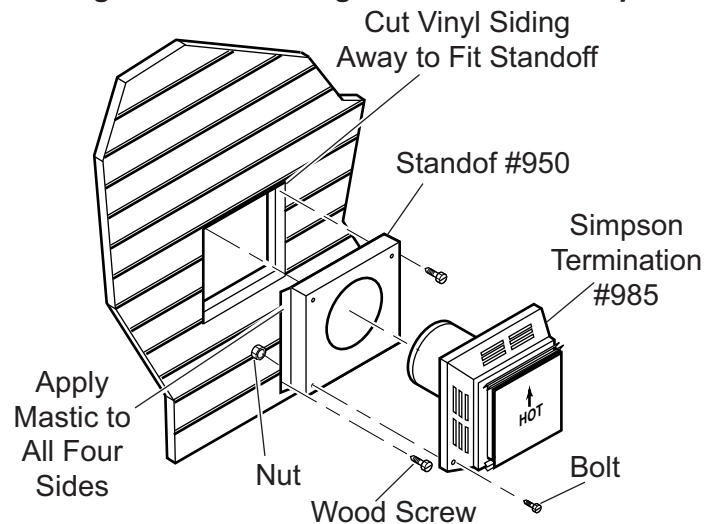

Figure 19 - Installing Simpson Vinyl Siding Standoff and Termination

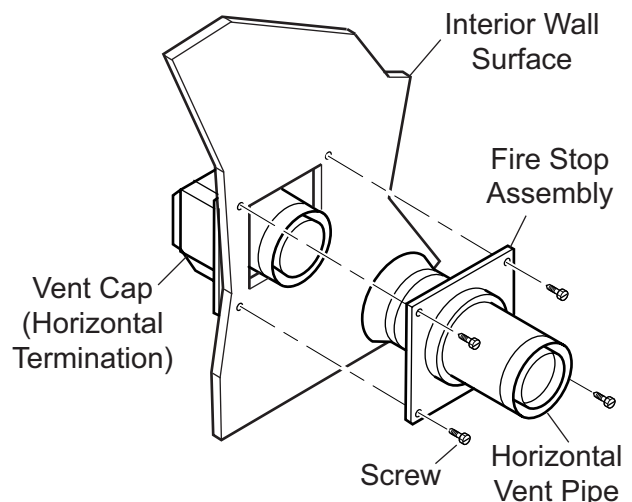

Figure 20 - Connecting Vent Cap with Horizontal Vent Pipe

HORIZONTAL (THROUGH THE WALL) TERMINATION CONFIGURATIONS

Since it is very important that the venting system maintain its balance between the combustion air intake and the flue gas exhaust, certain limitations as to vent configurations apply and must be strictly adhered to.

The Vent Graph, showing the relationship between vertical and horizontal side wall venting, will help to determine the various dimensions allowable. *See page 18.*

Minimum clearance between vent pipes and combustible materials is 3" on top and 1" from bottom and sides unless otherwise noted (Exception: Outside wall with firestop: 1" all around pipes are allowed).

When vent termination exits through foundations less than 20" below siding outcrop, the vent pipe must flush up with the siding.

It is best to locate the fireplace in such a way that minimizes the number of offsets and horizontal vent length.

The horizontal vent run refers to the total length of vent pipe from the flue collar of the fireplace (or the top of the transition elbow) to the face of the outer wall or the mounting flange of the termination.

WARNING When installing the appliance as a rear vent unit, the 90° 45° transition elbow attached directly to the rear of the unit is NOT INCLUDED in the following criteria and calculations, and unless specifically mentioned should be ignored when calculating venting layouts.

- The maximum number of 90° elbows per side wall installation is three (3). *See Figure 21.*
- If a 90° elbow is fitted directly on top of the fireplace flange, the maximum horizontal vent run before the termination or a vertical rise is 20" (508mm). *See Figure 22.*

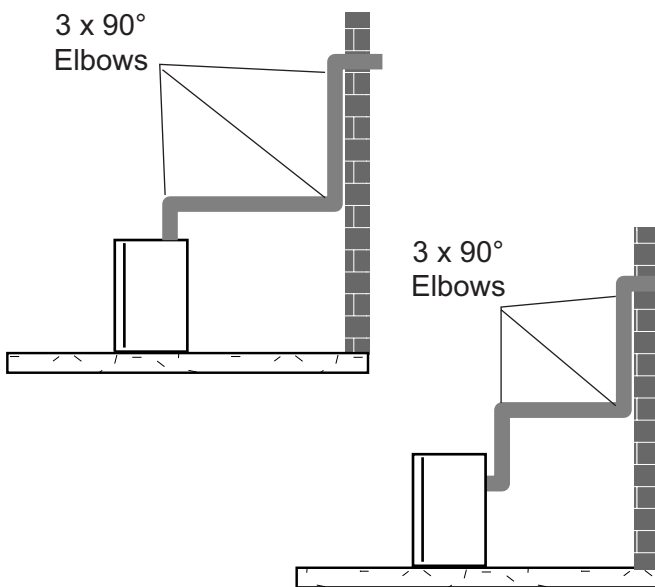

Figure 21 - Maximum Three (3) 90° Elbows Per Installation

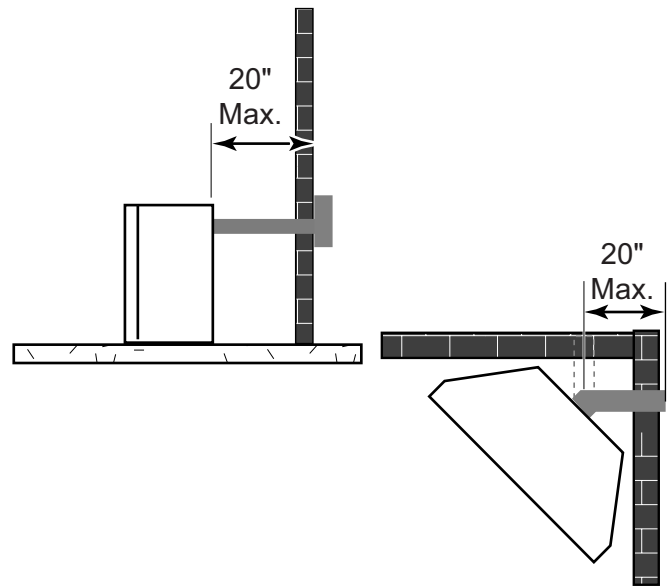

Figure 22 - Maximum Horizontal Run with No Rise

VENT INSTALLATION

HORIZONTAL (THROUGH THE WALL) TERMINATION CONFIGURATION *(Continued)*

- If a 90° elbow is used in the horizontal vent run (level height maintained) the horizontal vent length is reduced by 36" (914 mm) (Fig. 21 A and B) This does not apply if the 90° elbows are used to increase or redirect a vertical rise. See Figure 24.

Example: According to the vent graph (page 17) the maximum horizontal vent length in a system with a 7.5' vertical rise is 20' (6m) and if a 90° elbow is required in the horizontal vent it must be reduced to 17' (5.2 m).

In Figures 23 and 24, Dimension A plus B must not be greater than 17' (5.2m).

- The maximum number of 45° elbows permitted per side wall installation is two (2). These elbows can be installed in either the vertical or horizontal run.
- For each 45° elbow installed in the horizontal run, the length of the horizontal run MUST be reduced by 18" (45cm). This does not apply if the 45° elbows are installed on the vertical part of the vent system.
- The maximum number of elbow degrees in a system is 270°. See Figure 25.

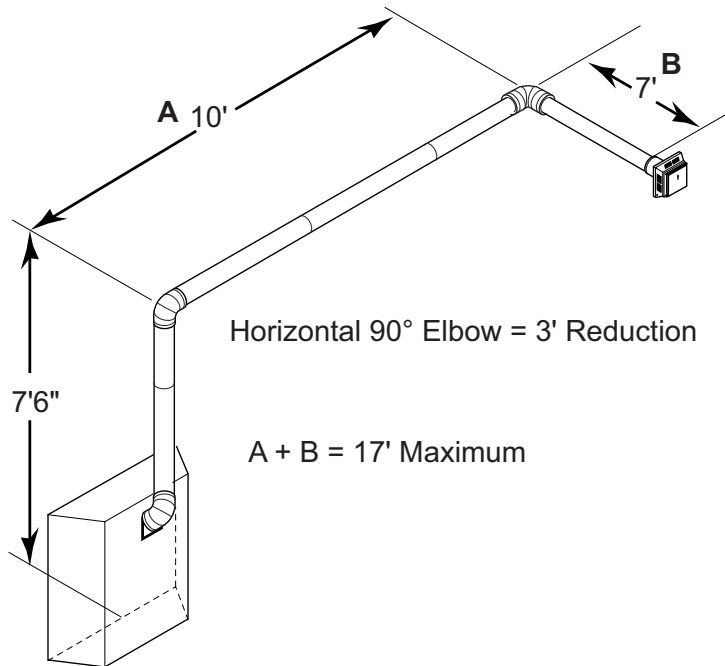

Figure 24 - Maximum Vent Run with Elbows

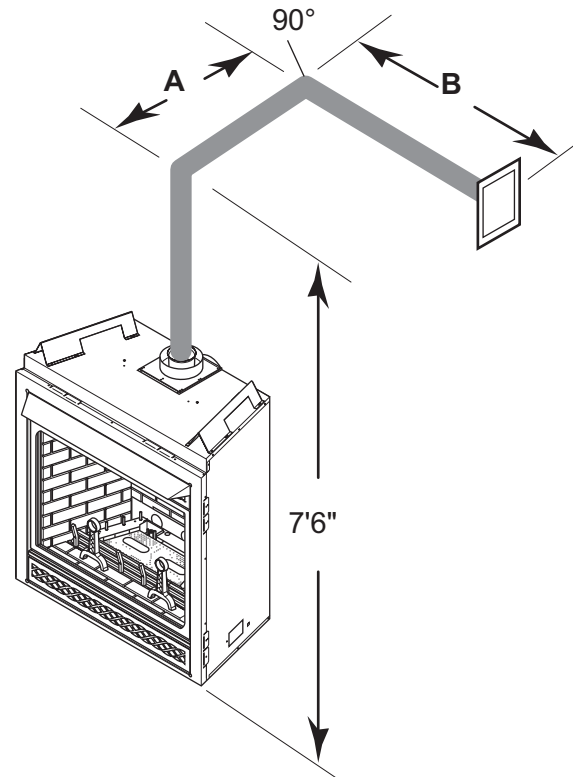

Figure 23 - Horizontal Run Reduction

Example:

Elbow 1 =	90°
Elbow 2 =	45°
Elbow 3 =	45°
Elbow 4 =	90°
<hr/>	
Total Angular Variation =	270°

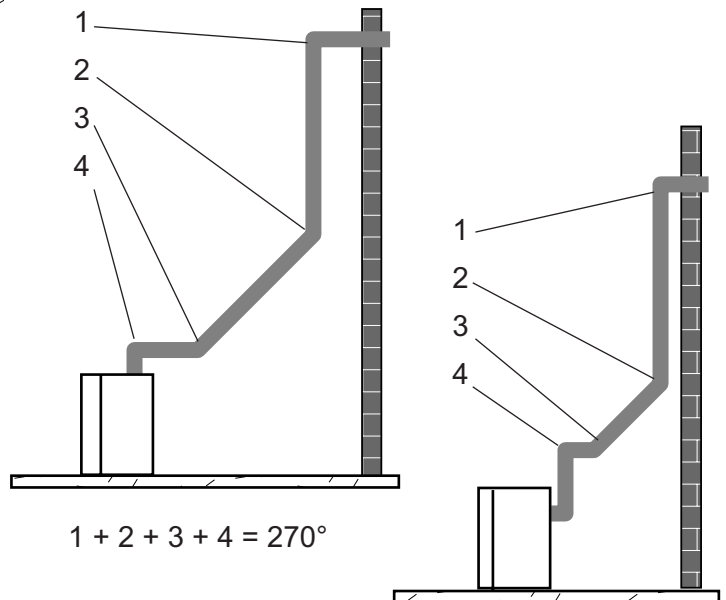

Figure 25 - Maximum Elbow Usage

BELOW GRADE INSTALLATIONS

When it is not possible to meet the required vent terminal clearances of 12" above grade level, a snorkel kit is recommended. It allows installation depth down to 7" (178mm) below grade level. The 7" (178mm) is measured from the center of the horizontal vent pipe as it penetrates through the wall.

Ensure that sidewall venting clearances are observed. If venting system is installed below ground, we recommend a window well with adequate and proper drainage to be installed around the termination area.

If installing a snorkel, a minimum 24" vertical rise is necessary. The maximum horizontal run with the 24" vertical pipe is 36". This measurement is taken from the collar of the fireplace (or transition elbow) to the face of the exterior wall. See the Sidewall Venting Graph for extended horizontal run if the vertical exceeds 24".

1. Establish vent hole through the wall. *See Figure 17, page 19.*
2. Remove soil to a depth of approximately 16" below base of snorkel. Install drain pipe. Install window well (not supplied). Refill hole with 12" of coarse gravel leaving a clearance of approximately 4" below snorkel. *See Figure 26.*
3. Install vent system.
4. Ensure a watertight seal is made around the vent pipe coming through the wall.
5. Apply high temperature sealant caulking (supplied) around the 4" and 7" snorkel collars.
6. Slide the snorkel into the vent pipes and secure to the wall.
7. Level the soil so as to maintain a 4" clearance below snorkel. *See Figure 26.*

WARNING

- Do not back fill around snorkel.
- A clearance of at least 4" must be maintained between the snorkel and the soil.

If the foundation is recessed, use recess brackets (not supplied) for securing lower portion of the snorkel. Fasten brackets to wall first, then secure to snorkel with self drilling #8x¹/₂ sheet metal screws. It will be necessary to extend vent pipes out as far as the protruding wall face. *See Figure 27.*

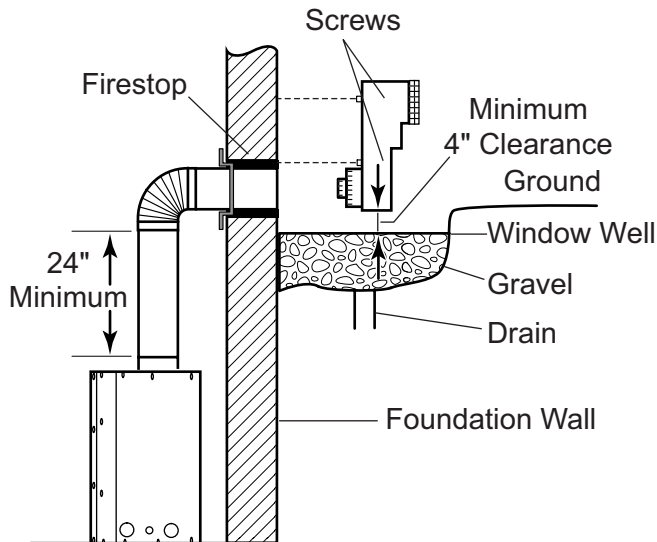

Figure 26 - Below Grade Installation

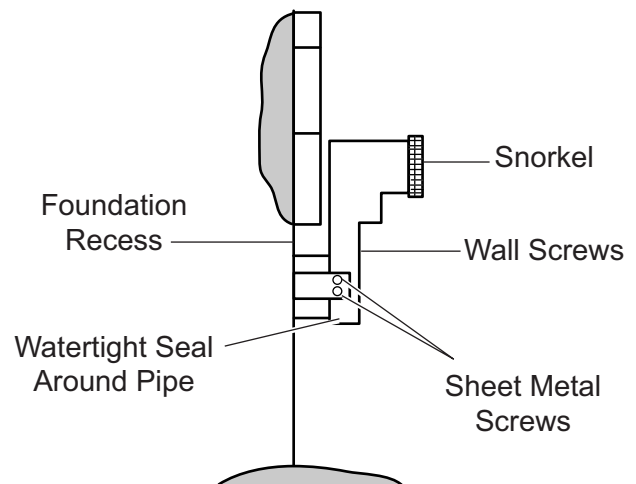

Figure 27 - Snorkel Installation, Recessed Foundation

VENT INSTALLATION

VERTICAL THROUGH-THE-ROOF APPLICATIONS

NOTICE

A restrictor disc must be installed on any vertical termination that is higher than 12'.

Install restrictor disc into 4" fireplace collar or first vent sections. See Figure 28.

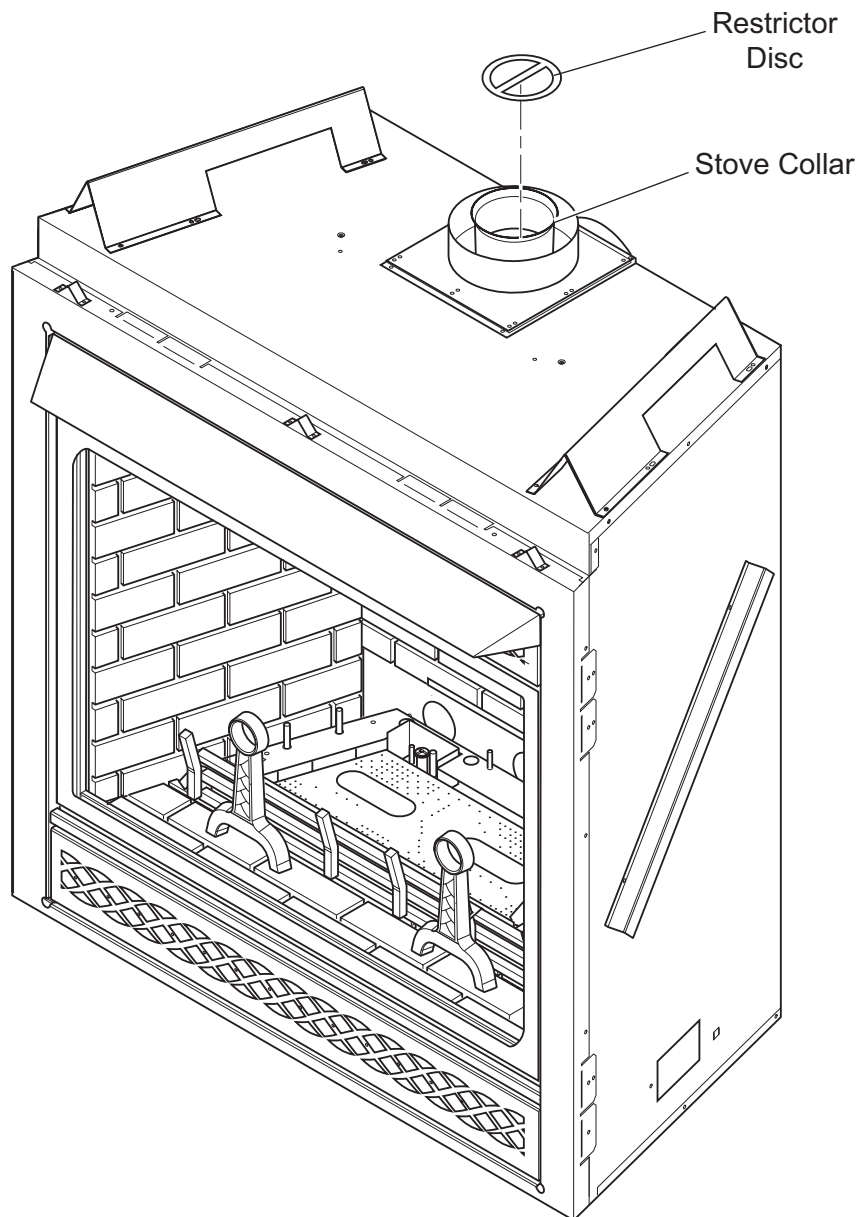

Figure 28 - Installing Restrictor Disc into Stove Collar

VERTICAL THROUGH-THE-ROOF APPLICATIONS *(continued)*

This Gas Fireplace has been approved for,

- Vertical installations up to 40' (12m) in height. Up to a 10' (3m) horizontal vent run can be installed within the vent system using a maximum of two 90° elbows. See Figure 29.

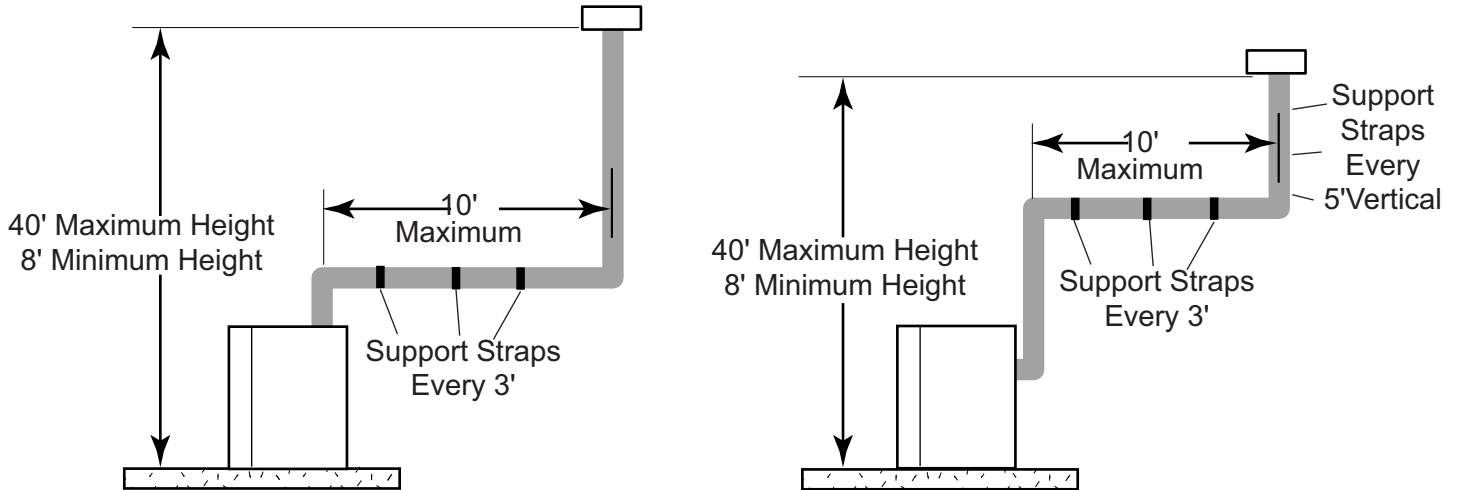

Figure 29 - Support Straps for Horizontal Runs

- Up to two 45° elbows may be used within the horizontal run. For each 45° elbow used on the horizontal plane, the maximum horizontal length must be reduced by 18" (450mm).

Example: Maximum horizontal length

No elbows = 10' (3m)

1x45° elbows = 8.5' (2.6m)

2x45° elbows = 7' (2.1m)

- A minimum of an 8' (2.5m) vertical rise is required.
- Two sets of 45°elbows offsets may be used within the vertical sections. From 0 to a maximum of 8' (2.5 m) of vent pipe can be used between elbows. See Figure 30.
- Determine the roof pitch and use the appropriate starter kit for offset installation.
- The maximum angular variation allowed in the system is 270°. See Figure 30.
- The minimum height of the vent above the highest point of penetration through the roof is 2' (610mm).

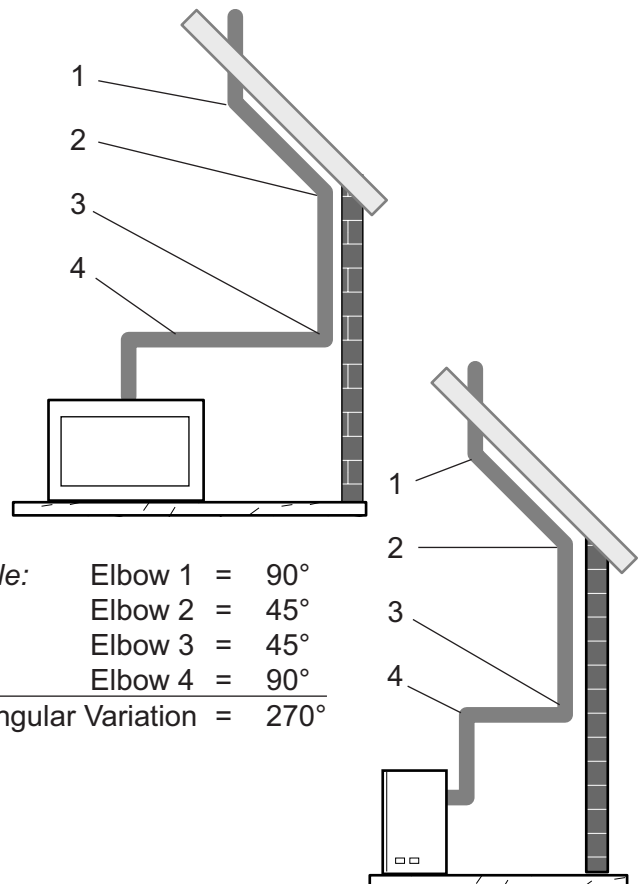

Example:

Elbow 1	=	90°
Elbow 2	=	45°
Elbow 3	=	45°
Elbow 4	=	90°
Total Angular Variation		= 270°

Figure 30 - Maximum elbow Usage

VENT INSTALLATION

INSTALLATION FOR VERTICAL TERMINATION

1. Determine the route your vertical venting will take. If ceiling joist, roof rafters or other framing will obstruct the venting system, consider an offset. See *Figure 31* to avoid cutting load bearing members.

NOTE: Pay special attention to these installation instructions for required clearances (air space) to combustibles when passing through ceilings, walls, roofs, enclosures, attic rafters, etc. Do not pack air spaces with insulation. Also note maximum vertical rise of the venting system and any maximum horizontal offset limitations. Offsets must fall within the parameters shows in *Figure 14*, page 18.

2. Set fireplace in desired location. Drop a line plumb down from the ceiling to the position of the flue exit. Mark the center point where the vent will penetrate the ceiling. Drill a small locating hole at this point.

Drop a plumb line from the inside of the roof to the ceiling locating hole in the ceiling. Mark the center point where the vent will penetrate the roof. Drill a small locating hole at this point.

FLAT CEILING INSTALLATION

1. Cut a 9 $\frac{1}{2}$ " (241mm) square hole in the ceiling using the locating hole as a center point. The opening should be framed to 9 $\frac{1}{2}$ "x9 $\frac{1}{2}$ " (241mm x 241mm) inside dimensions as shown in *Figure 32* using framing lumber the same size as the ceiling joist. If the area above the ceiling is an insulated ceiling or a room, nail firestop from the top side. This prevents loose insulation from falling into the required clearance space. See *Figure 32*. Otherwise, install firestop below the framed hole. The firestop should be installed with no less than three nails per side. See *Figure 33*.
2. Assemble the desired lengths of pipe and elbows necessary to reach from the burner system flue up through the firestop. Be sure pipe and elbow connections are fully twist-locked. See *Figure 17*, page 19.
3. Cut a hole in the roof using the locating hole as a center point. (Cover any exposed open vent pipes before cutting hole in roof). The 9 $\frac{1}{2}$ "x9 $\frac{1}{2}$ " (241mm x 241mm) hole must be measured on the horizontal. Actual length may be larger depending on the pitch of the roof. There must be a 1" minimum clearance from the vent pipe to combustible materials. (Insulation should be considered a combustible material) Frame the opening as shown in *Figure 16* on page 19.

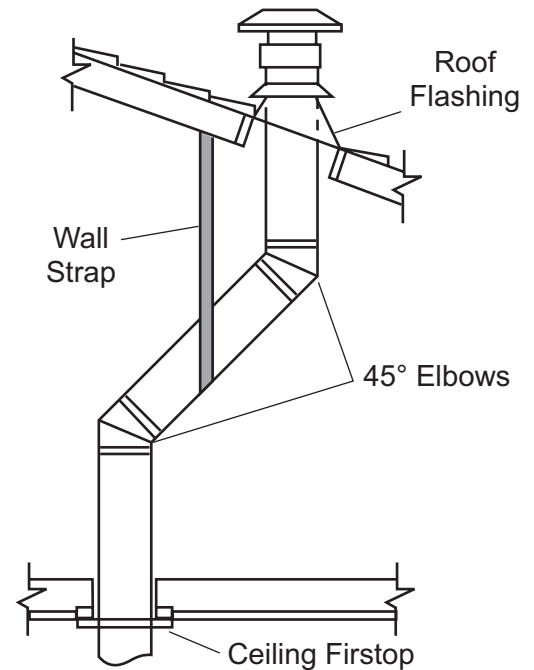

Figure 31 - Offset with Wall Strap and 45° Elbows

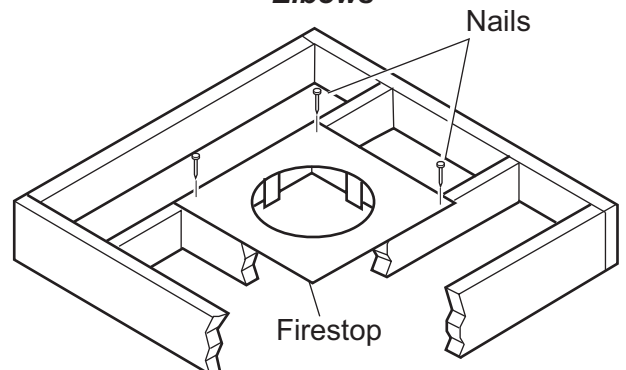

Figure 32 - If area above is a room, install firestop above framed hole as shown

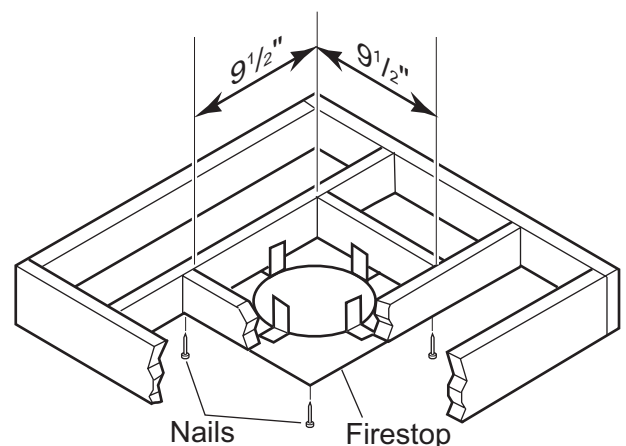

Figure 33 - If area above is not a room, install firestop below framed hole as shown

Continued on next page

INSTALLATION FOR VERTICAL TERMINATION (CONTINUED)

4. Connect a section of pipe and extend up through the hole.

NOTE: If an offset is needed to avoid obstructions, you must support the vent pipe every three (3) feet. Use wall straps for this purpose. See Figure 31, page 26. Whenever possible, use 45° elbows instead of 90° elbows. The 45° elbow offers less restriction to the flow of the flue gases and intake air.

5. Place the flashing over the pipe section(s) extending through the roof. Secure the base of the flashing to the roof and framing with roofing nails. Be sure roofing material overlaps the top edge of the flashing. There must be a 1" clearance from the vent pipe to combustible materials.

6. Continue to add pipe sections until the height of the vent cap meets the minimum requirements below.

NOTE: You must increase vent height for steep roof pitches. Nearby trees, adjoining roof lines, steep pitched roofs, and other similar factors may cause poor draft or down-drafting in high winds. Increasing the vent height may solve this problem.

NOTE: If the vent pipe passes through any occupied areas above the first floor, including storage spaces and closets, you must enclose pipe. You may frame and sheetrock the enclosure with standard construction material. Make sure to meet the minimum allowable clearances to combustibles. Do not fill any of the required clearance spaces with insulation.

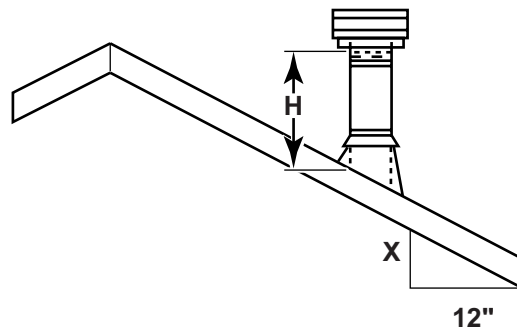

Figure 34 - Minimum Chimney Clearance

TERMINATION HEIGHT TABLE		
Use this table to determine the minimum height above the roof.		
	Minimum Height	
Roof Pitch	Feet	Meters
Flat to 7/12	1	0.3
Over 7/12 to 8/12	1.5	0.46
Over 8/12 to 9/12	2	0.61
Over 9/12 to 10/12	2.5	0.76
Over 10/12 to 11/12	3.25	0.99
Over 11/12 to 12/12	4	1.22
Over 12/12 to 14/12	5	1.52

FIREPLACE INSTALLATION

CHECK GAS TYPE

Use proper gas type for the fireplace you are installing. If you have conflicting gas type, do not install fireplace. See dealer where you purchased the fireplace for proper fireplace according to your gas type.

INSTALLING GAS PIPING TO FIREPLACE LOCATION

INSTALLATION ITEMS NEEDED

Before installing fireplace and burner system, make sure you have the items listed below.

- External regulator (supplied by installer)
- Tee joint
- Piping (check local codes)
- Pipe wrench
- Sealant (resistant to propane/LP gas)
- Test gauge connection*
- Sediment trap (optional but recommended)
- approved flexible gas line with gas connector (if allowed by local codes — not provided)

* A CSA design-certified equipment shutoff valve with 1/8" NPT tap is an acceptable alternative to test gauge connection. Purchase the CSA design-certified equipment shutoff valve from your dealer.

For propane/LP connections only, the installer must supply an external regulator. The external regulator will reduce incoming gas pressure. You must reduce incoming gas pressure to between 11 and 13 inches of water. If you do not reduce incoming gas pressure, burner system regulator damage could occur. Install external regulator with the vent pointing down as shown in *Figure 35*. Pointing the vent down protects it from freezing rain or sleet.

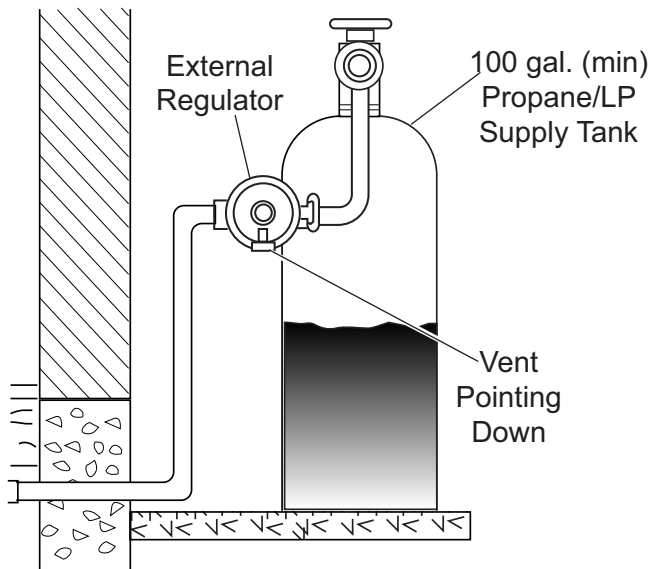

Figure 35 - External Regulator with Vent Pointing Down (Propane/LP Only)

When using copper or flex connectors use only fittings approved for gas connections. The gas control inlet is 3/8" NPT.

WARNING

A qualified installer or service person must connect appliance to gas supply. Follow all local codes.

CAUTION

For propane/LP units, never connect fireplace directly to the propane/LP supply. This burner system requires an external regulator (not supplied). Install the external regulator between the burner system and propane/LP supply.

CAUTION

Use only new black iron or steel pipe. Internally tinned copper or copper tubing can be used per National Fuel Code, section 2.6.3, providing gas meets hydrogen sulfide limits, and where permitted by local codes. Gas piping system must be sized to provide minimum inlet pressure (listed on data plate) at the maximum flow rate (BTU/hr). Undue pressure loss will occur if the pipe is too small.

WARNING

External regulators may be necessary for natural gas. One- or two-pound systems will damage this appliance and may cause fire hazard.

FIREPLACE INSTALLATION

WARNING

Only persons licensed to work with gas piping may make the necessary gas connections to this appliance.

CAUTION

A manual shutoff valve must be installed upstream of the appliance. Union tee and plugged $\frac{1}{8}$ " NPT pressure tapping point should be installed upstream of the appliance. See *Figure 35*.

NOTE : The gas line connection may be made using $\frac{1}{2}$ " rigid tubing or an approved flex connector. Since some municipalities have additional local codes it is always best to consult your local authorities and the current edition of the National Fuel Gas Code ANSI.Z223.1, NFPA54. In Canada CAN/CGA-B149 (1 or 2) Installation Code.

A listed manual shutoff valve must be installed upstream of the appliance. Union tee and plugged $\frac{1}{8}$ " NPT pressure tapping point should be installed upstream of the appliance. See *Figure 36*.

IMPORTANT: Install main gas valve (equipment shutoff valve) in an accessible location. The main gas valve is for turning on or shutting off the gas to the fireplace.

Check your building codes for any special requirements for locating equipment shutoff valve to fireplaces.

Apply pipe joint sealant lightly to male threads. This will prevent excess sealant from going into pipe. Excess sealant in pipe could result in clogged burner system valves.

CAUTION

Use pipe joint sealant that is resistant to liquid petroleum (LP) gas.

We recommend that you install a sediment trap/drip leg in supply line as shown in *Figure 36*. Locate sediment trap/drip leg where it is within reach for cleaning. Install in piping system between fuel supply and burner system. Locate sediment trap/drip leg where trapped matter is not likely to freeze. A sediment trap traps moisture and contaminants. This keeps them from going into the burner system gas controls. If sediment trap/drip leg is not installed or is installed wrong, burner system may not run properly.

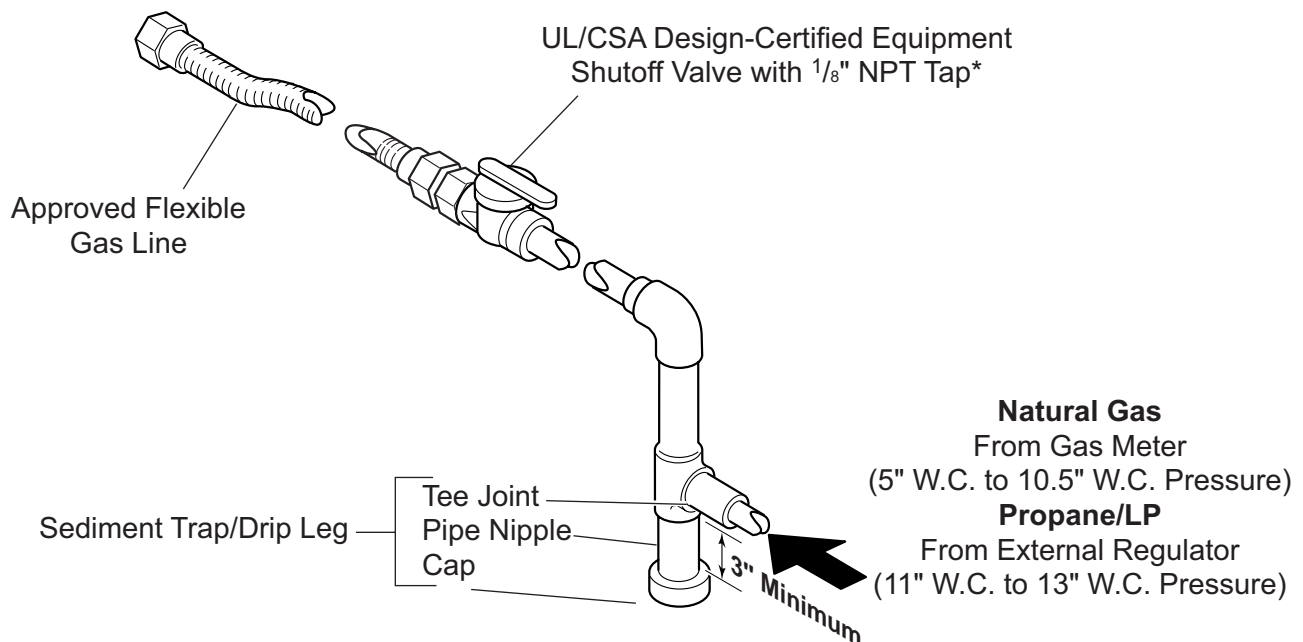

Figure 36 - Gas Connection

CHECKING GAS PRESSURE

1. Check gas type. The gas supply must be the same as stated on the appliance's rating decal. If the gas supply is different from the fireplace, STOP! Do not install the appliance. Contact your dealer immediately.
2. To ease installation, a 30" (mm) flex line with manual shut-off valve has been provided with on this appliance. Install and attach 1/2" gas line onto shut-off valve.
3. After completing gas line connection, purge air from gas line and test all gas joints from the gas meter to the fireplace for leaks. Use a solution of 50/40 water and soap or a gas sniffer.
4. To adjust flame height, turn HI/LO knob to HI to get maximum pressure to burner. Turn HI/LO knob to LO to get minimum pressure.
5. To check gas pressures at valve, turn captured screw counter clockwise 2 or 3 turns and then place tubing to pressure gauge over test point. Turn unit to high. See *Figure 37*. After taking pressure reading, be sure and turn captured screw clockwise firmly to reseal. Do not over torque. Check test points for gas leaks.

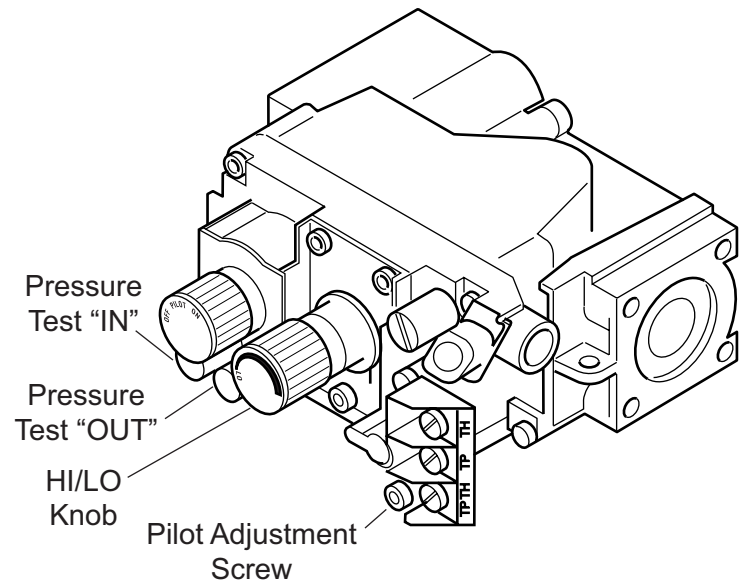

Figure 37 - Gas Pressure Check at Gas Valve

WARNING

Do not use open flame to check for gas leaks.

ELECTRICAL WIRING

This fireplace will work without any electrical supply. Electricity is only needed to operate blower.

NOTE: *If installed in mobile home, fireplace must be bolted securely to floor.*

WARNING

Electrical connections should only be performed by a qualified, licensed electrician. Main power must be off when connecting to main electrical power supply or performing service. All wiring shall be in compliance with all local, city, and state codes. The appliance, when installed, must be electrically grounded in accordance with local codes, or in the absence of local codes, with the *National Electrical Code ANSI/ NFPA 70 (latest edition)* and *Canadian Electrical Code, CSA C22.1*.

CAUTION

Label all wires before disconnecting when servicing controls. Wiring errors can cause improper and dangerous operation.

Verify proper operation after servicing.

REMOTE WALL MOUNTED SWITCH

A remote wall switch and up to fifteen (15) feet of 18 Ga. wire may be used with this appliance. Attach the wall switch in a junction box at the desired location on the wall. *See Figure 38.* Do not extend beyond the wall switch wire length provided.

NOTE: *Extended lengths of wire may cause the fireplace not to function properly. Longer length of wire is permitted if the wire is made out of larger gauge (diameter) wire. Always check with local code.*

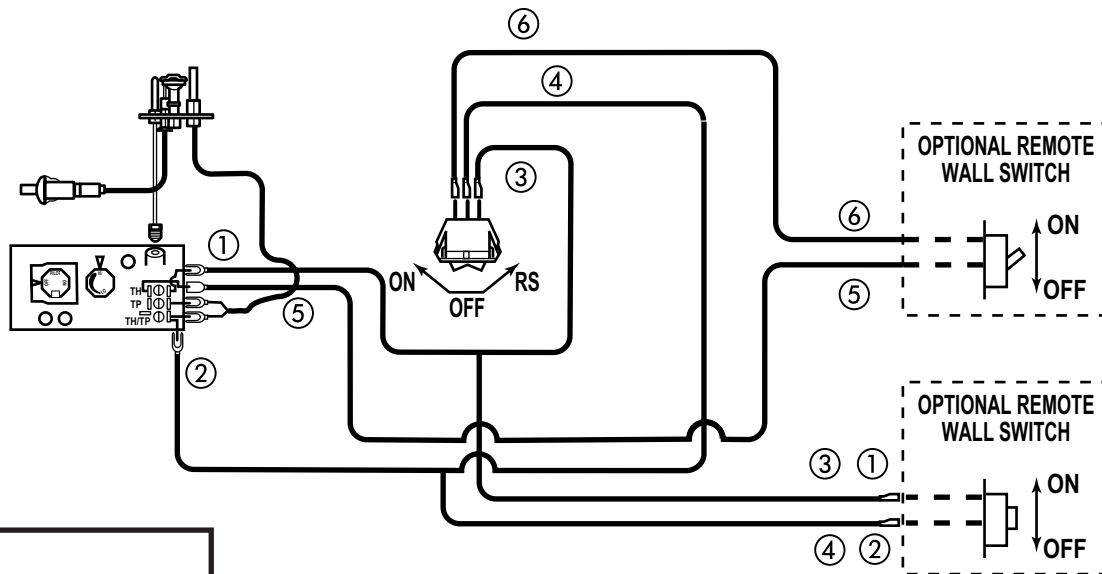

Figure 38 - Wiring Diagram for Wall Switch

WARNING

Do not connect wall switch to AC (110V) circuit.

ELECTRICAL INSTALLATION

ELECTRONIC PILOT IGNITION WIRING

WARNING

Do not connect 110-120 VAC to the Remote Wall Switch. The appliance will malfunction or destroyed.

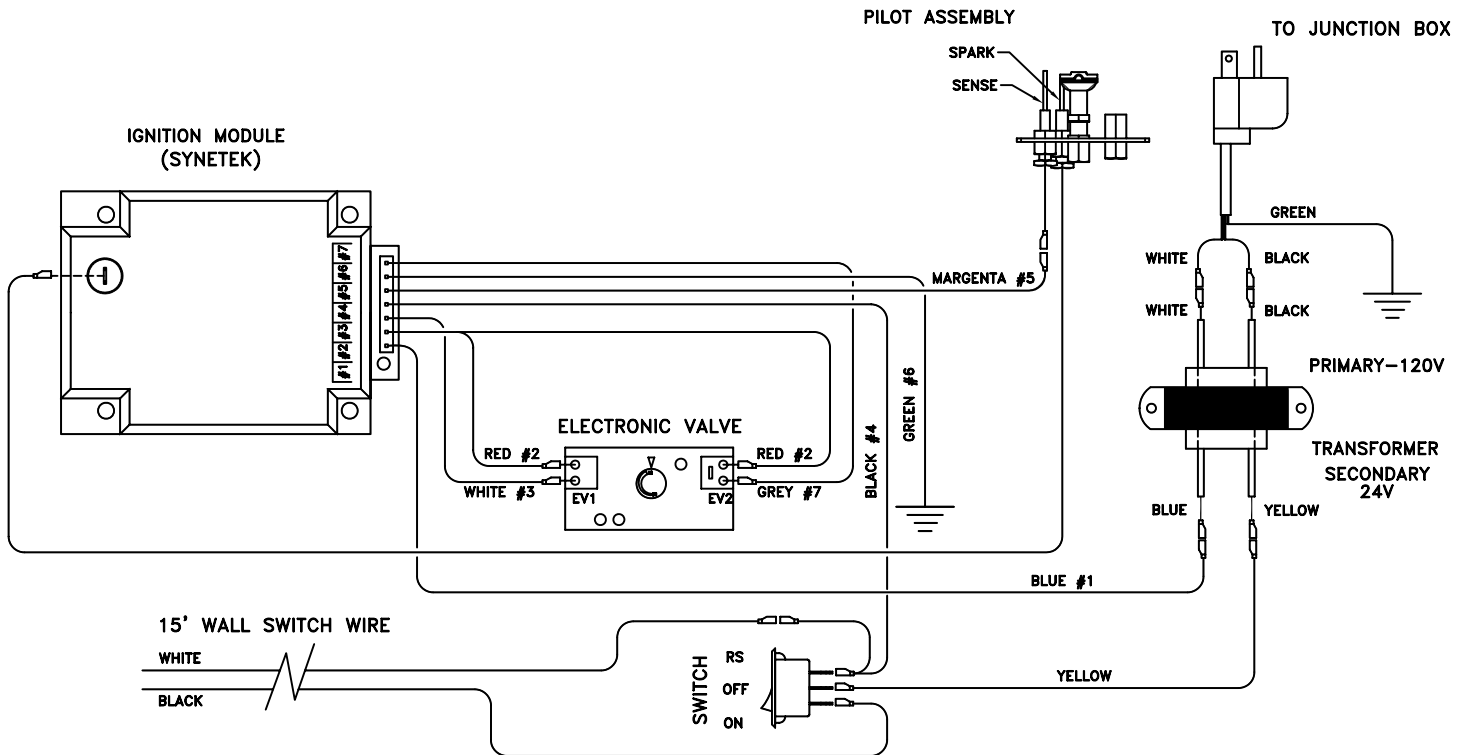

Figure 39 - Electronic Ignition System Wiring Diagram

REMOTE WALL SWITCH

Position the wall switch. Do not extend beyond the 15 feet of wire.

OPTIONAL DC REMOTE SYSTEMS

These instructions replace the section entitled *Hearth Mount* in the Millivolt hand held remote instructions supplied with the remote.

1. Plug in remote connector wire to remote receiver.
2. Connect the wire terminal from the remote receiver. This replaces the 15' wall switch connection to the switch. See *Figure 39*.
3. Mount remote control receiver at junction box (for your wall switch).

CANOPY INSTALLATION

1. Unhook top filigree. Set aside. *See Figure 40.*
2. Remove canopy from top of unit.
3. Attach canopy to underside of top outer shell with three (3) screws provided. *See Figure 41.*
3. Reinstall filigree.

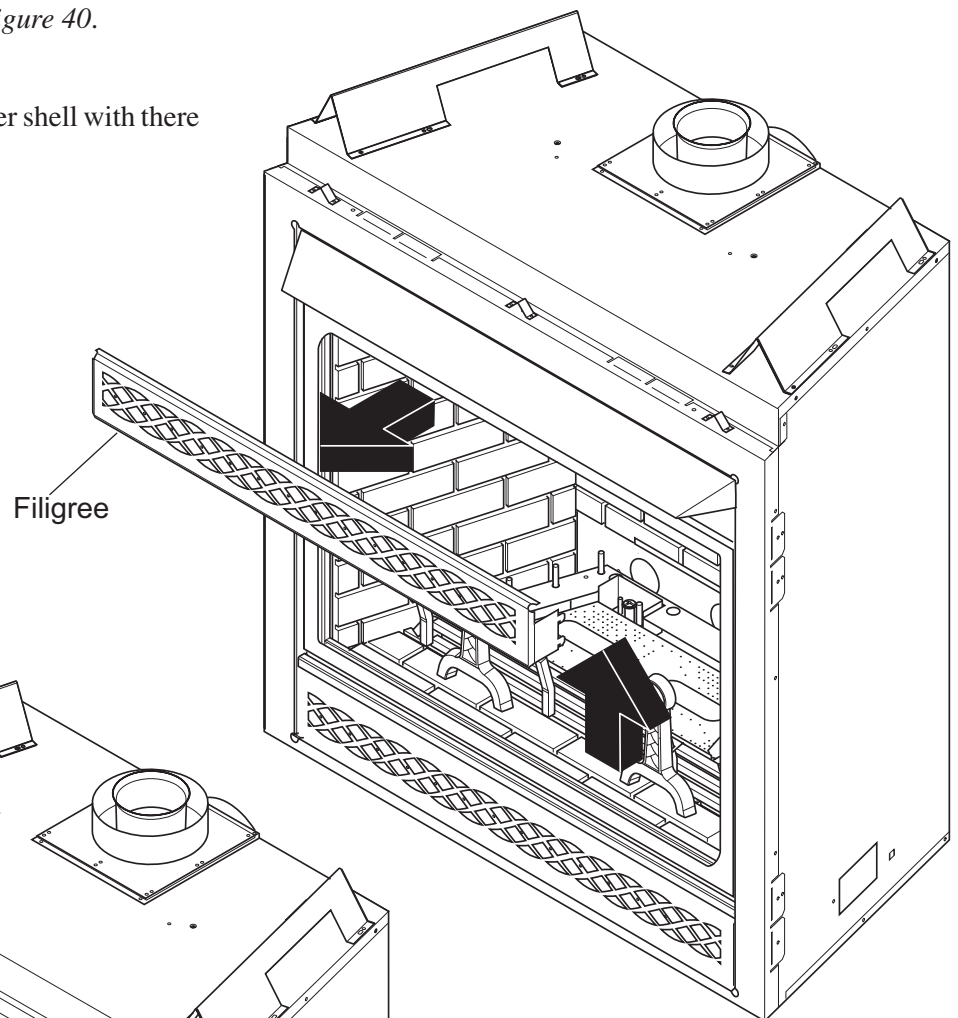

Figure 40 - Removing Filigree

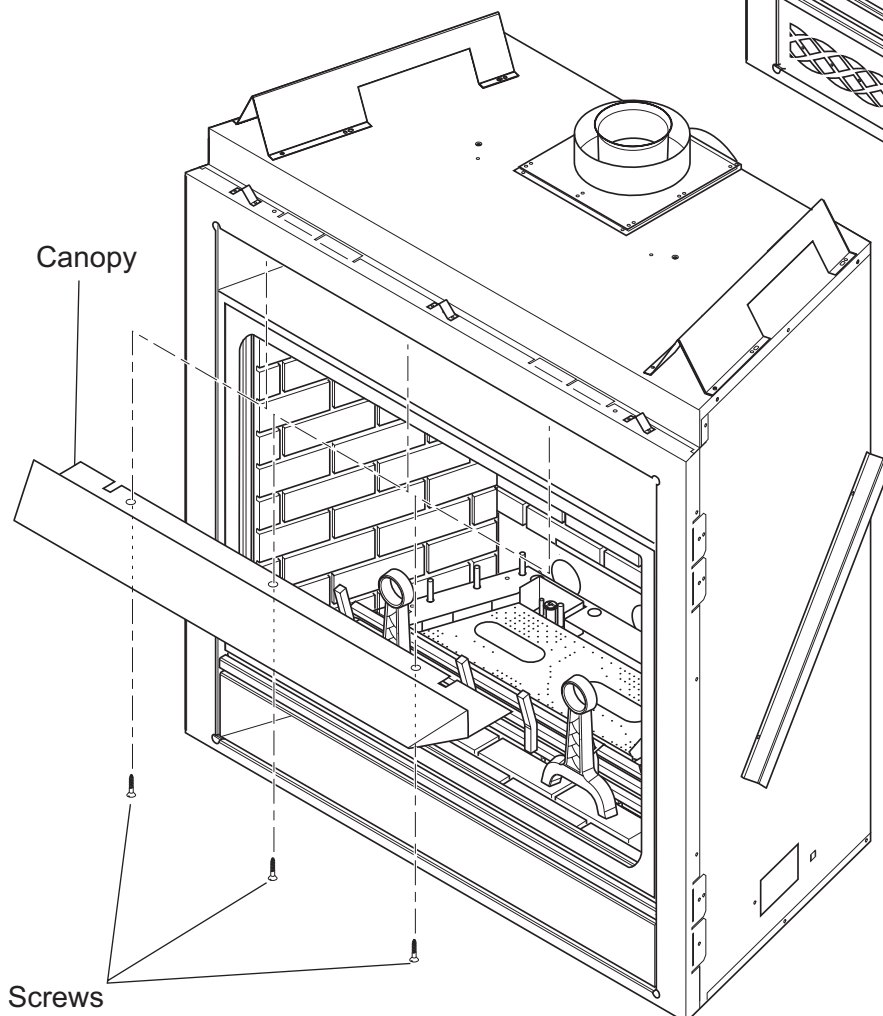

Figure 41 - Installing Canopy

GLASS REMOVAL

GLASS FRAME REMOVAL

1. Remove filigree from the top.
2. Release two clamps on bottom of fireplace. *See Figure 42.*
3. Tilt glass frame out and lift glass frame up until it clears three tabs on top of fireplace.
4. Set glass frame aside.

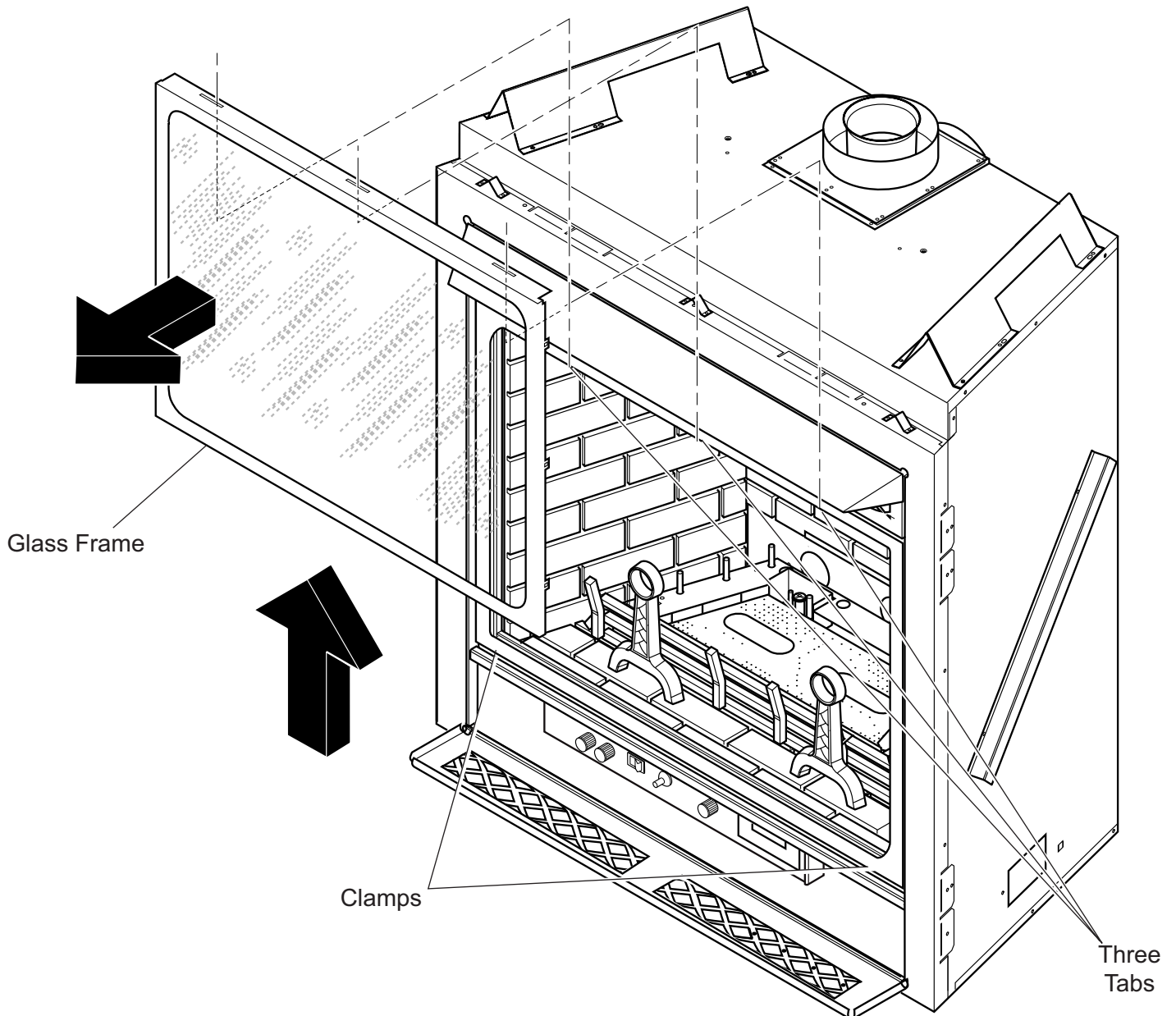

Figure 42 - Removing Glass Frame

CAUTION

Each clamp has a quick spring force. When reinstalling clamps, keep fingers clear.

ROCK WOOL PLACEMENT

1. Place rock wool on burner to provide glowing embers. For best results, pull the rock wool apart into pieces the size of a nickel or smaller.
2. Place the logs on the burner. See *Log Placement* page 37.
3. Distribute one layer of rock wool to cover all burner ports. Fill front gap between grate and burner. See *Figure 43*.
4. Light unit and after 15 minutes, check burner flame and glow. See *Burner Flame*, page 36.

If the flame is blue and only in the center, turn off unit and let cool. After unit cools, remove logs. If the back holes are clear, add more rock wool to the center of the burner. Replace logs and check flame again. Save left over rock wool to refresh when cleaning later. Too much rock wool can disturb the flame and cause sooting on the glass or logs.

WARNING

Do not use the entire bag of rock wool to cover the burner. This could cause the flame to burn poorly and may lead to sooting.

WARNING

Do not sprinkle the lava rock or ember chunks on top of the burner. This may cause potential sooting, glass breakage and a fire hazard.

LAVA ROCK AND EMBERS PLACEMENT

Sprinkle lava rock on the floor of the inner combustion chamber. Evenly distribute the rock. Do not pile the lava rock up in front of grate. Do not place lava rock on the burner. If desired, purchase optional embers to decorate the floor of the fireplace.

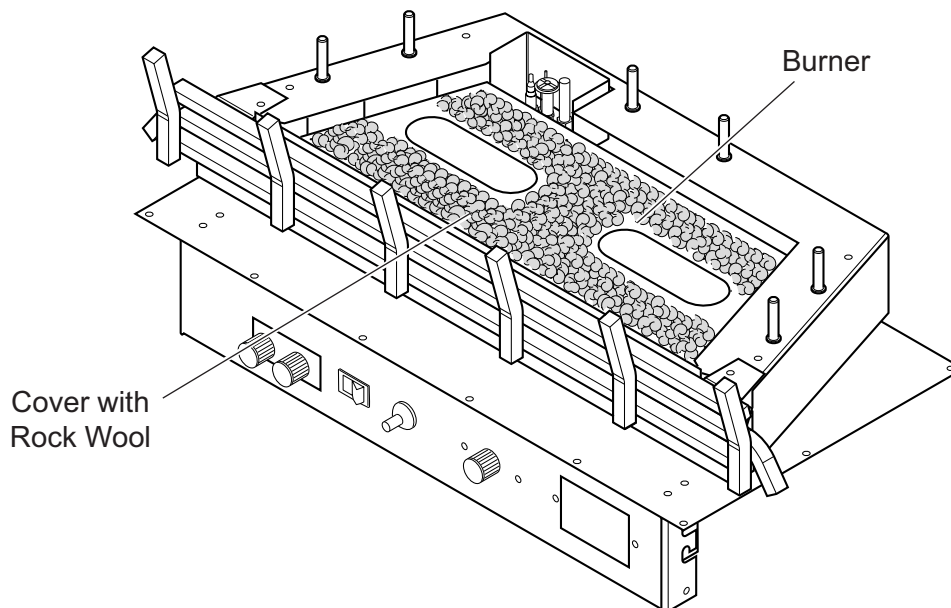

Figure 43 - Placement of Rock Wool on Burner

ANDIRON INSTALLATION

1. Remove two (2) brackets and two (2) bolts from package.
2. Attach bracket to back of each andiron with bolts provided. *See Figure 44.*
3. Line up the rectangle hold on bracket with grate bar. *See Figure 45.*
4. Push bracket down until it snaps into place.

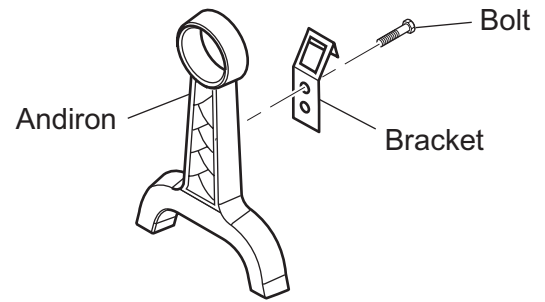

Figure 44 - Installing Andiron

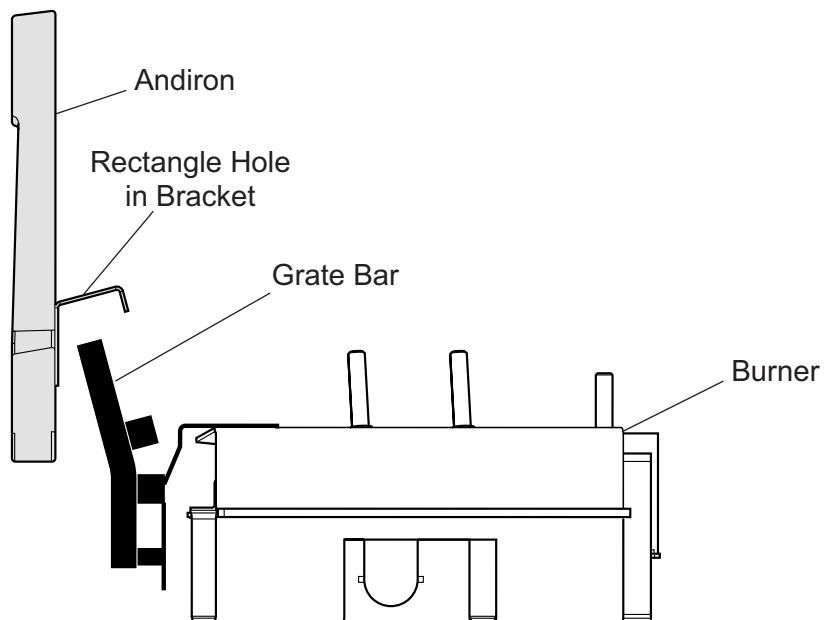

Figure 45 - Installing Andiron

LOG PLACEMENT

1. Place rear log (#1) on grate assembly. Log should rest firmly on the two log mounting pins at the back of the plate. *See Figure 46.*
2. Place bottom right log (#2) on grate. Log should rest firmly on two right mounting pins of plate. *See Figure 47.*
3. Place bottom left log (#3) on grate. Log should rest firmly on two left mounting pins of plate. *See Figure 48.*

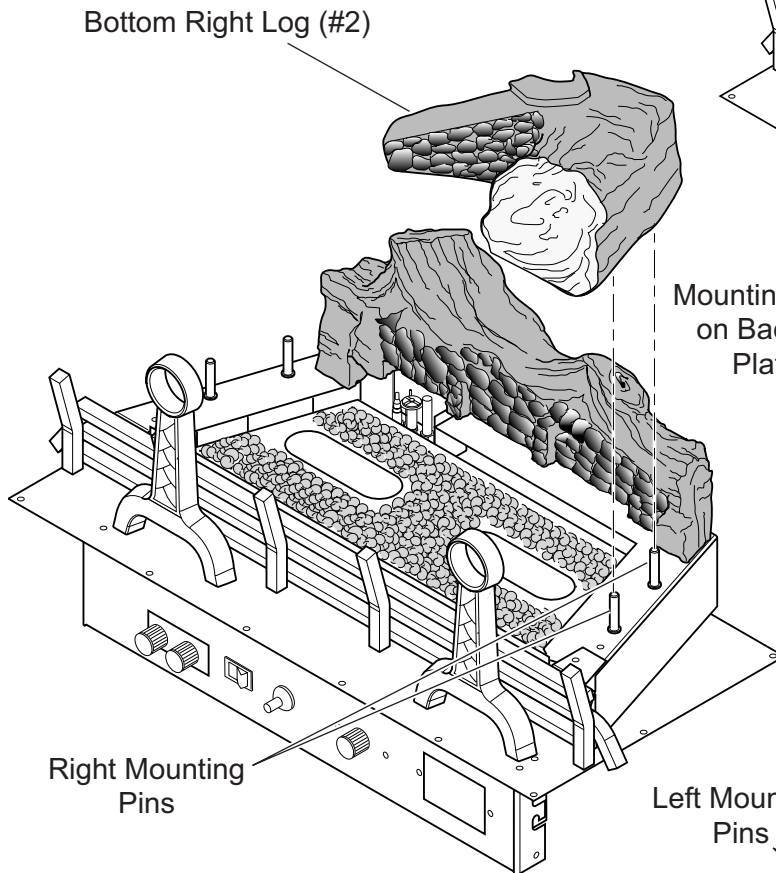

Figure 47 - Installing Bottom Right Log (#2)

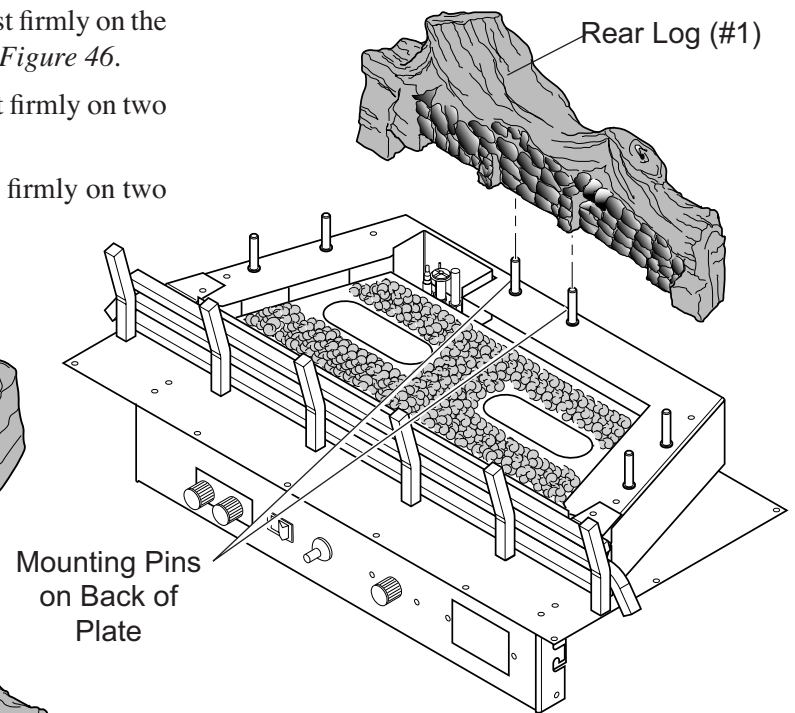

Figure 46 - Installing Rear Log (#1)

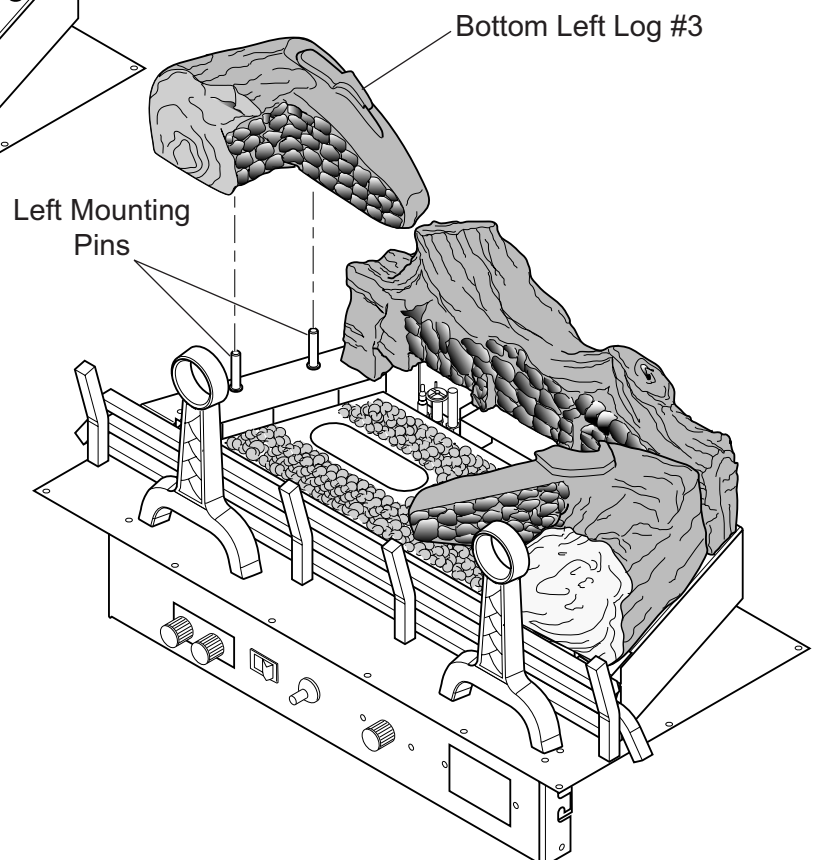

Figure 48 - Installing Bottom Left Log (#3)

LOG PLACEMENT

4. Line up the indentation on bottom of right top log (#4) with protrusion on top of right bottom log. See *Figure 49*.
5. Line up the indentation on bottom of top left log (#5) with the protrusion on top of bottom left log. See *Figure 50*.
6. Logs should all be properly installed as in *Figure 51*.

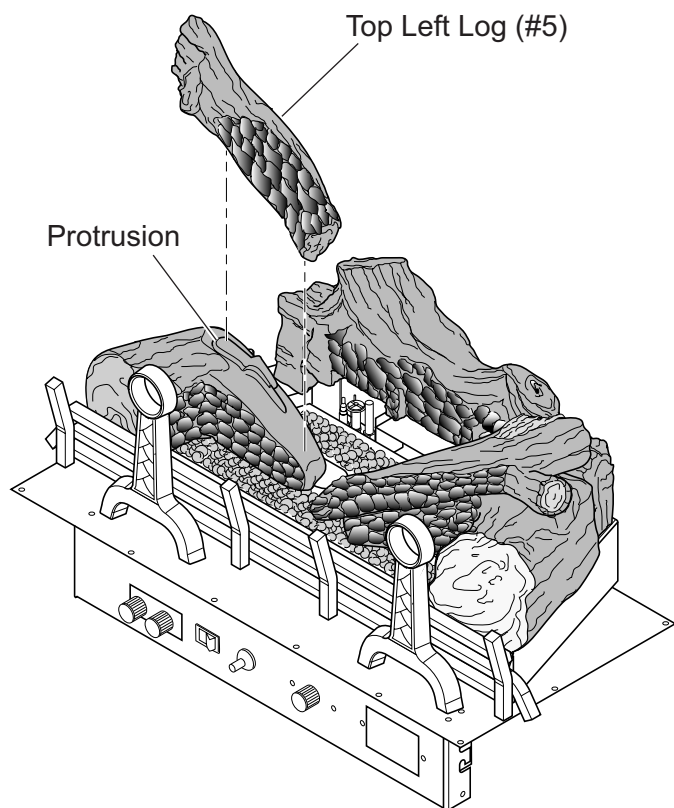

Figure 50 - Installing Right Top Log (#5)

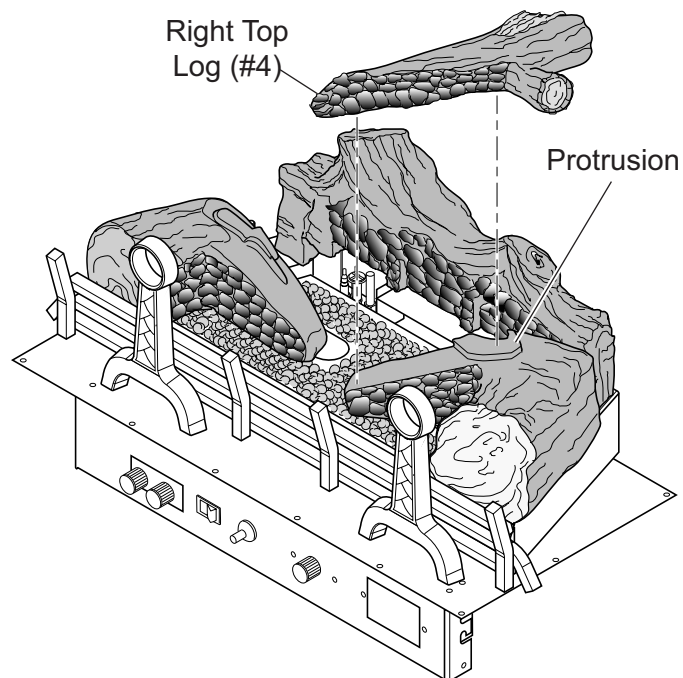

Figure 49 - Installing Right Top Log (#4)

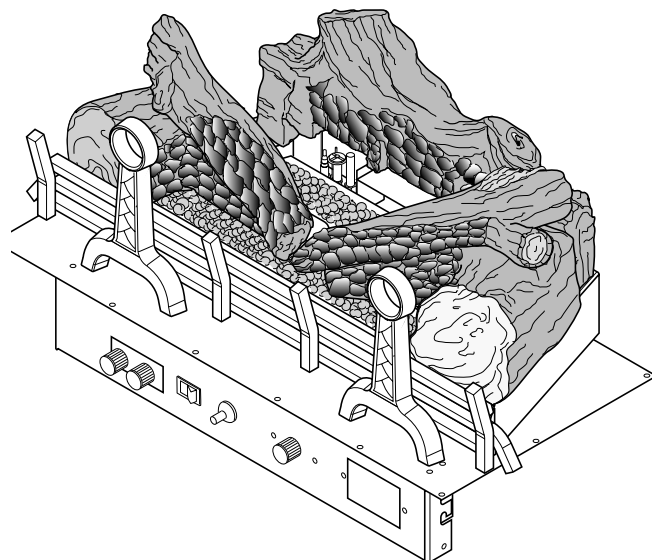

Figure 51 - View of All Logs Properly Installed

FOR YOUR SAFETY READ BEFORE LIGHTING**WARNING**

If you do not follow these instructions exactly, a fire or explosion may result causing property damage, personal injury or loss of life.

- A.** This appliance is equipped with a pilot which must be lit with built-in battery ignitor while following these instructions exactly.
- B.** BEFORE OPERATING smell all around the appliance area for gas. Be sure to smell next to the floor because some gas is heavier than air and will settle on the floor.

WHAT TO DO IF YOU SMELL GAS:

- Turn off all gas to the appliance.
 - Open windows.
 - Do not attempt to light any appliance.
 - Do not touch any electric switch; do not use any phone in your building.
 - Immediately call your gas supplier from a neighbor's phone. Follow the gas supplier's instructions.
 - If you cannot reach your gas supplier, call the fire department.
- C.** Use only your hand to push in, or turn the gas control knob. Never use tools. If the knob will not push in or turn by hand, don't try to repair it. Call a qualified service technician. Force or attempted repair may result in a fire or explosion.
 - D.** Do not use this appliance if any part of it has been under water. Immediately call a qualified service technician to inspect the appliance and to replace any part of the control system and any gas control that has been under water.

LIGHTING PILOT FOR THE FIRST TIME**INITIAL LIGHTING**

Purge air from the supply line as follows:

- Open main shutoff valve.
- Unscrew main pressure test point.
- Leave inlet test screw open until gas comes in.
- When gas is flowing, tighten inlet screw immediately.

WARNING

Never use an open flame to check for gas leak.

LEAK TESTING

1. Follow the pipe from the gas supply line connection to the gas valve. Check connection for leaks with soap and water mixture.
2. Next check for gas leaks at the burner with soap and water mixture.
3. Check the pilot for gas leaks with soap and water mixture.

OPERATING INSTRUCTIONS

LIGHTING PILOT FOR THE FIRST TIME

APPROVED LEAK TESTING METHOD

You may check for gas leaks with the following methods only:

- Soap and water solution
- An approved leak testing spray
- Electronic sniffer

DANGER

Never check for gas leak with open flame!

WARNING

If using a soap and water solution to test for leaks, **DO NOT** spray solution onto control body.

NOTE: Remove any excessive pipe compound from the connections. Excessive pipe compound can set off electronic sniffers.

Check for gas leaks in each of the following locations:

- Pipe from the gas supply line connection to the gas valve
- Burner connections
- Pilot
- Each joint or connection
- Field made joints / gas shutoff valve
- Factory made joints
- All joints on valve and control body

LIGHTING PILOT

WARNING

The control has an interlock device that does not allow the lighting of the fireplace up to the moment the safety device of the flame has not interrupted the gas flow. After that period of time (when the magnet is closed), it is possible to start the lighting operation.

The gas control knob is designed to be operated by hand. **DO NOT** use any tools during this operation. Damaged knobs may result in serious injury.

1. Depress and turn knob counterclockwise  to pilot position.
2. Depress fully and hold pilot gas knob. The electronic ignitor will automatically ignite the pilot. Keep knob fully depressed for a few seconds. Release and check that pilot continues to burn.

If the pilot does not stay lit, repeat steps 1 and 2.

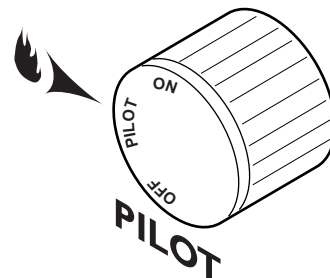

Figure 52 - Pilot Position

Continued on next page

LIGHTING BURNER

MAIN BURNER SWITCH

The “ON/OFF” switch for the main burner can be found behind door of the fireplace. This switch allows you to turn on and to turn off the main burner without using the gas valve knob. Make sure the button is in the “ON” position to light the main burner. *See Figure 53.*



Figure 53 - On/Off/RS Switch

LIGHTING THE BURNER

Depress and turn the knob counterclockwise  to the “ON” position. *See Figure 54.* It will take less than four (4) seconds for the burner to ignite.

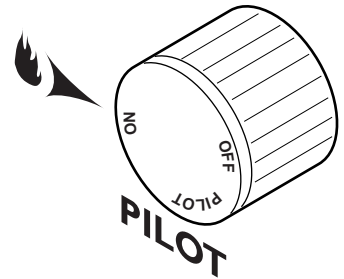

Figure 54 - On Position

PILOT POSITION

Depress and turn knob to pilot position to keep burner off while maintaining the pilot light. *See Figure 55.*

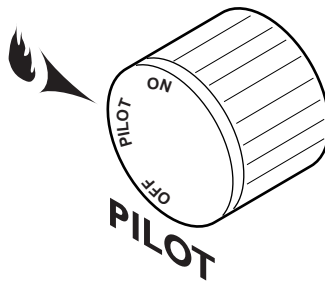

Figure 55 - Pilot Position

TO TURN OFF GAS

Depress and turn knob clockwise  to “OFF” position. *See Figure 56.*

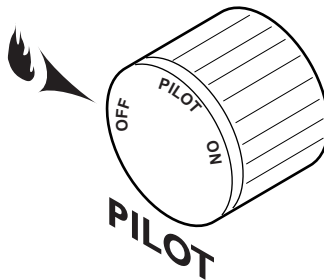

Figure 67 - Off Position

OPERATING INSTRUCTIONS

FOR YOUR SAFETY READ BEFORE LIGHTING

- A. This appliance is equipped with an ignition device (Piezo) which automatically lights the pilot. Do **NOT** try to light the burner by hand.
- B. **BEFORE OPERATING** smell all around the appliance area for gas. Be sure to smell next to the floor because some gas is heavier than air and will settle on the floor.

WHAT TO DO IF YOU SMELL GAS:

- Turn off all gas to the appliance.
 - Open windows.
 - Do not attempt to light any appliance.
 - Do not touch any electric switch; do not use any phone in your building.
 - Immediately call your gas supplier from a neighbor's phone. Follow the gas supplier's instructions.
 - If you cannot reach your gas supplier, call the fire department.
- C. Turn off all electric power to appliance.
 - D. Do not use this appliance if any part of it has been under water. Immediately call a qualified service technician to inspect the appliance and to replace any part of the control system and any gas control that has been under water.

WARNING

If you do not follow these instructions exactly, a fire or explosion may result causing property damage, personal injury or loss of life.

WARNING

Never use an open flame to check for gas leak.

LIGHTING ELECTRONIC IGN

1. STOP! Read the safety information above.
2. Set thermostat to lowest setting.
3. Turn off all electric power to the appliance.
4. This appliance is equipped with an ignition device which automatically lights the burner. Do not try to light the burner by hand.
5. Wait 5 minutes to clear out any gas. Then smell for gas, including near the floor. If you smell gas STOP! Follow "B" — *What to Do if You Smell Gas* above. If you do not smell gas, go to the next step.
6. Turn on all electric power to appliance.
7. Set thermostat to desired setting.
8. Turn RS-OFF-ON rocker switch to "ON".
9. If the appliance will not operate, follow the instruction *To Turn Off Gas* below and call your service technician or gas supplier.

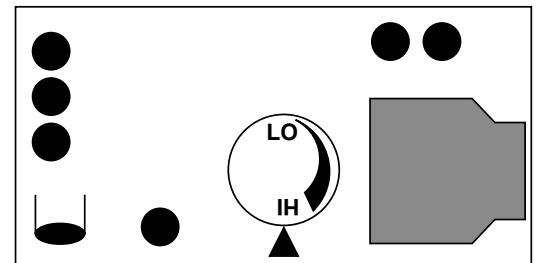

Figure 57 - Electronic Gas Valve

TO TURN OFF GAS

1. Open lower door.
2. Turn RS-OFF_ON rocker switch to "OFF".
3. Turn off all electric power to the appliance if service is to be performed.
4. Close lower door.

WARNING

Turn off gas before servicing fireplace. It is recommended that a qualified service technician perform these check-ups at the beginning of each heating season

BURNER, PILOT AND CONTROL COMPARTMENT

Keep the control compartment, logs, and burner areas surrounding the logs clean by vacuuming or brushing at least twice a year. Make sure the burner porting, pilot air opening and burner air opening are free of obstructions at all times.

PILOT FLAME

The flames from the pilot should be visually checked as soon as the heater is installed and periodically during normal operation. **The pilot flame must always be present when the fireplace is in operation.** See Figure 58. The pilot flame has three distinct flames, one engulfing the thermopile, one engulfing the thermocouple, and the other reaching to the main burner.

Thermocouple

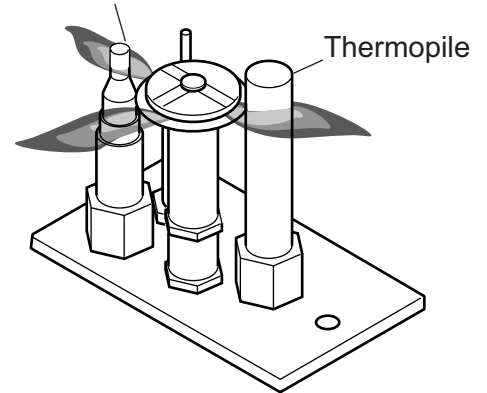

Figure 58 - Pilot Flame

BURNER

Inspect area around the injector. Remove any lint or foreign material with a brush or vacuum.

BURNER FLAME

The flames from the burner should be visually checked as soon as the heater is installed and periodically during normal operation. In normal operation, at full rate, and after operating for about 15 to 30 minutes, the flame should be yellow and slightly taller than the rear log. See Figure 59.

If the flame is blue and only in the center, turn off unit and let cool. After unit is cool, remove logs and check to make sure the back holes in the burner are not covered with rock wool. If the back holes are clear, add more rock wool to the center of the burner. Replace logs.

NOTE: The type of installation, vent system configuration, and wind effects may cause the flame patterns to vary.

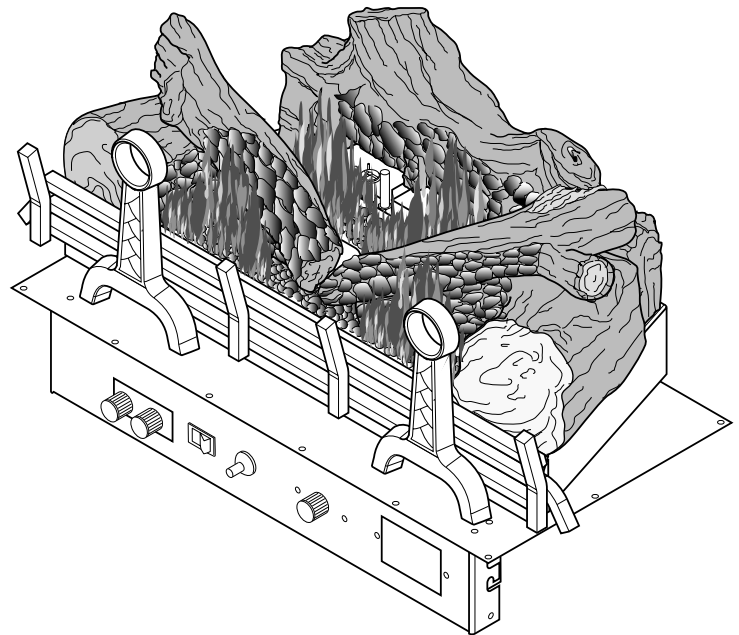

Figure 59 - Burner Flame Appearance

CLEANING AND MAINTENANCE

VENT SYSTEM

The fireplace and venting system should be inspected before initial use and at least annually by a qualified field service person. Inspect the external vent cap on a regular basis to make sure that no debris is interfering with the airflow. Inspect entire venting system to ensure proper function.

GLASS DOOR

Thoroughly clean the inside of the glass door after using the fireplace for ten hours. Periodically clean the glass door as necessary.

When cleaning the glass, remember:

- **Do not remove the glass when hot.** Allow glass to cool before removal.
- NEVER use abrasive materials.
- Keep children and pets a safe distance away.
- Never operate the fireplace without the glass door properly secured.
- Never operate the fireplace if the glass is broken.
- Replace any glass that is chipped, cracked, or broken. Replacement glass door assemblies **MUST** be supplied by the fireplace manufacturer – **No substitute materials may be used.**
- Handle glass door with care to avoid striking or scratching it on hard objects.

To clean glass door, follow “Glass Removal” procedure outlined in the *Final Installation* section. Film deposit on the inside of the glass should be cleaned off using a nontoxic, non-corrosive, non-abrasive, mild-cleaning solution. Simply apply an adequate amount to the glass and wipe off with a damp cloth. After all maintenance has been completed, re-install glass door.

LOGS

Leave logs installed in the fireplace for cleaning. Vacuum surface of the logs with a brush attachment. If logs must be removed for cleaning, handle carefully by holding gently at each end. Gloves are recommended to prevent skin irritation from ceramic fibers. If skin becomes irritated, wash gently with soap and water. Vacuum surface of logs with brush attachment or brush logs with a soft bristle brush (i.e. clean, dry paintbrush). To place logs back in the fireplace, see “Log Placement” found in the *Final Installation* section.

NOTE: Do not use cleaning fluid to clean logs.

ROCK WOOL

Replace or add rock wool as required following installation instructions in the *Final Installation* section of this manual.

ILLUSTRATED PARTS LIST

VENT COMPONENTS

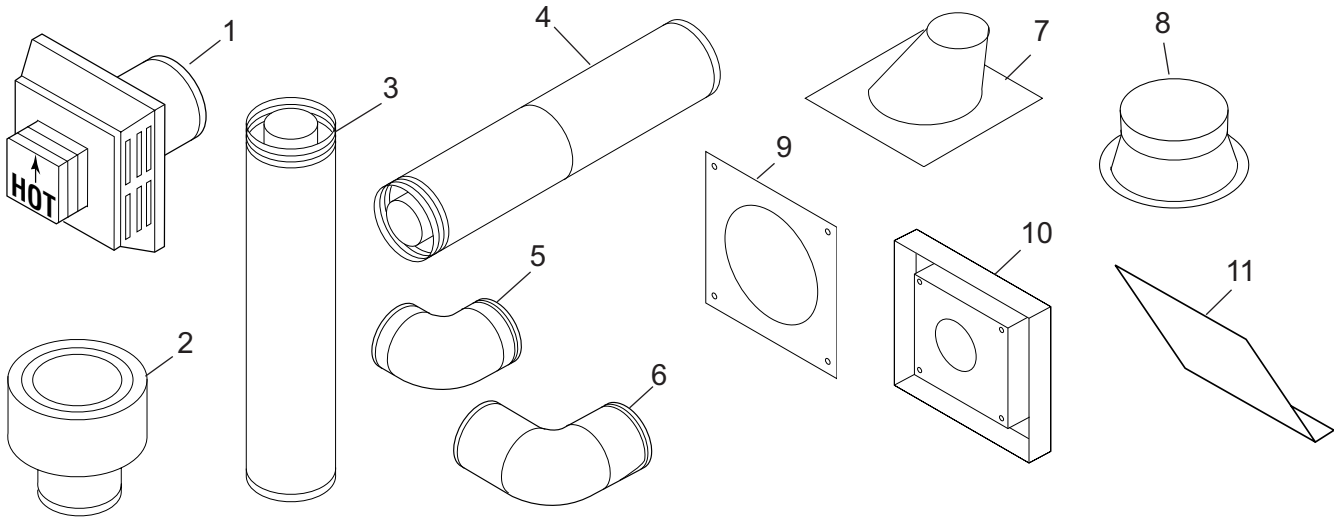

Item	Qty/ Box	Description	Simpson DuraVent or Other Approved Venting Components P/N
1	1	Simpson Horizontal High Wind Termination Cap	985
1	1	Horizontal Termination Cap with Built-In Vinyl Siding Standoff, Heat Deflector, Firestop and Adjustable Pipe 7" to 11"	BHRTK
1	1	Horizontal Termination Cap Built-In Vinyl Siding Standoff, Heat Deflector, Firestop, 90° Elbow and Adjustable Pipe 7" to 11"	BHSTK
1	1	Horizontal Termination Cap with Built-In Vinyl Siding Standoff, Heat Deflector, Firestop and Flexible Pipe 24" to 48"	BHSFTK
2	1	Vertical Termination Cap with Flashing, Storm Collar and Firestop	BVTK
2	1	Vertical Termination	980
3	6	6" Pipe Length	908
3	6	9" Pipe Length	907
3	6	12" Pipe Length	906
3	6	24" Pipe Length	904
3	6	36" Pipe Length	903
3	6	48" Pipe Length	902
4	6	11" To 14 5/8" Pipe, Adjustable	911
4	6	17" To 24" Pipe, Adjustable	917
5	6	45° Elbow	945
5	6	45° Swivel Elbow	945G
6	6	90° Elbow	990
6	6	90° Swivel Elbow	990G
7	6	Flashing, 0/12 To 6/12 Roof Pitch	943
8	6	Storm Collar	953
9	6	Firestop	963
10	1	Vinyl Siding Standoff	950
11	1	Deflector Shield	37D0115 (Monessen)

ILLUSTRATED PARTS LISTS

FIREBOX COMPONENTS

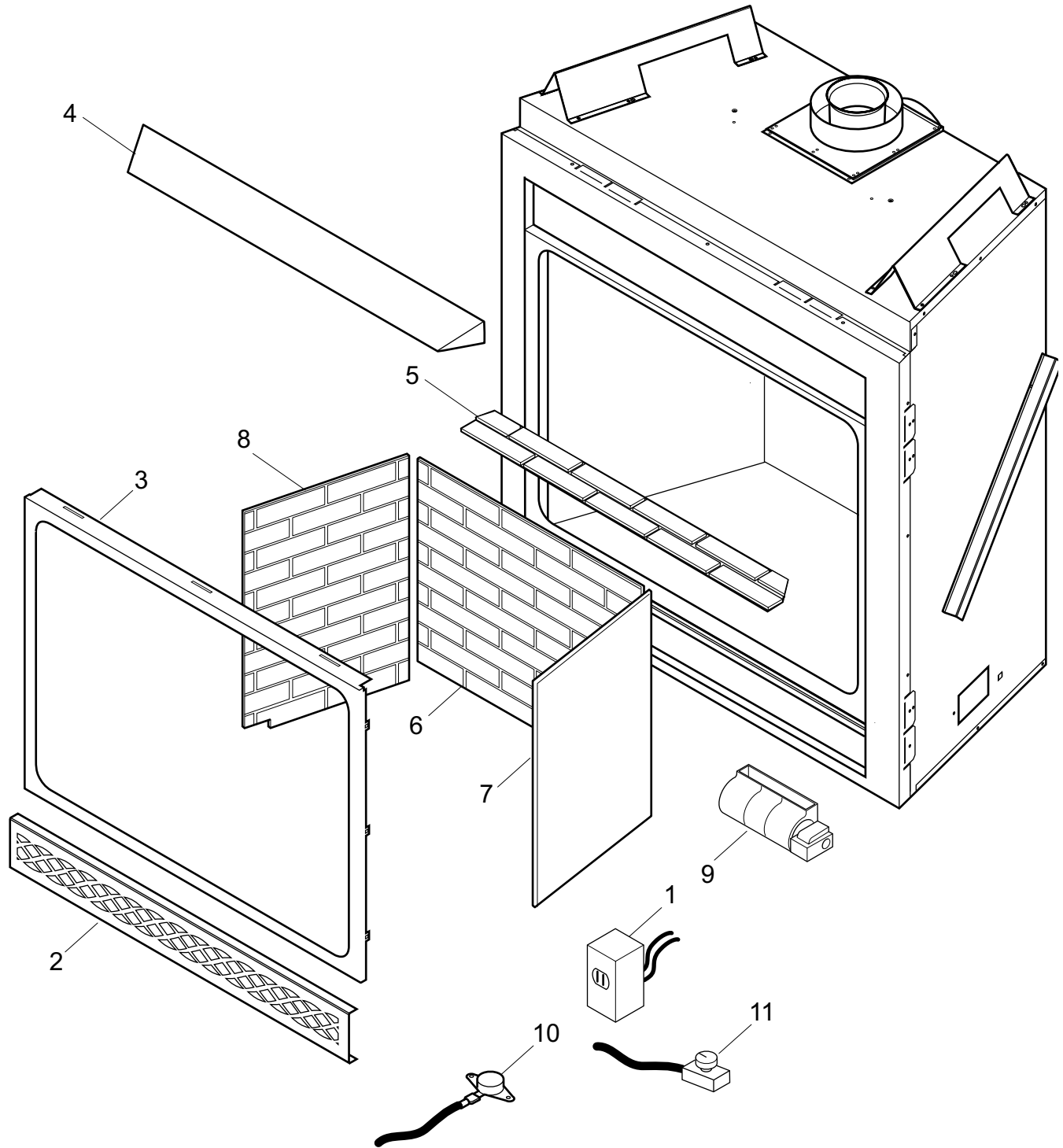

ILLUSTRATED PARTS LISTS

FIREBOX COMPONENTS

Item	Description	Qty	SDV500	SDV600
Standard Features				
1	Junction Box Assembly	1	26D2128K	26D2128K
2	Filigree Black	2	56D0192	56D0672
3	Glass Frame Assembly	1	56D0108	56D0608
4	Canopy	1	56D0277	56D0697
Factory Installed Options				
5	Firebox Floor	1	56D0014	56D0014
6	Standard Firebrick Center	1	56D0013	56D0013
7	Standard Firebrick Right	1	56D0012	56D0012
8	Standard Firebrick Left	1	56D0011	56D0011
9	Blower Motor	1	26D0748	26D0748
10	Thermostat Sensor	1	26D2870	26D2870
Accessories/Field Installed Options				
6,7,8	Weathered Firebrick Walls	1	FBS500W8B	FBS600W8B
11	T-stat Blower with Speed Control	1	BLOT	BLOT

LOGS

Item	Description	Qty	SDV500	SDV600
1	Rear Log	1	56D0002	56D0002
2	Bottom Right Log	1	56D0004	56D0004
3	Bottom Left Log	1	56D0003	56D0003
4	Top Right Log	1	56D0006	56D0006
5	Top Left Log	1	56D0005	

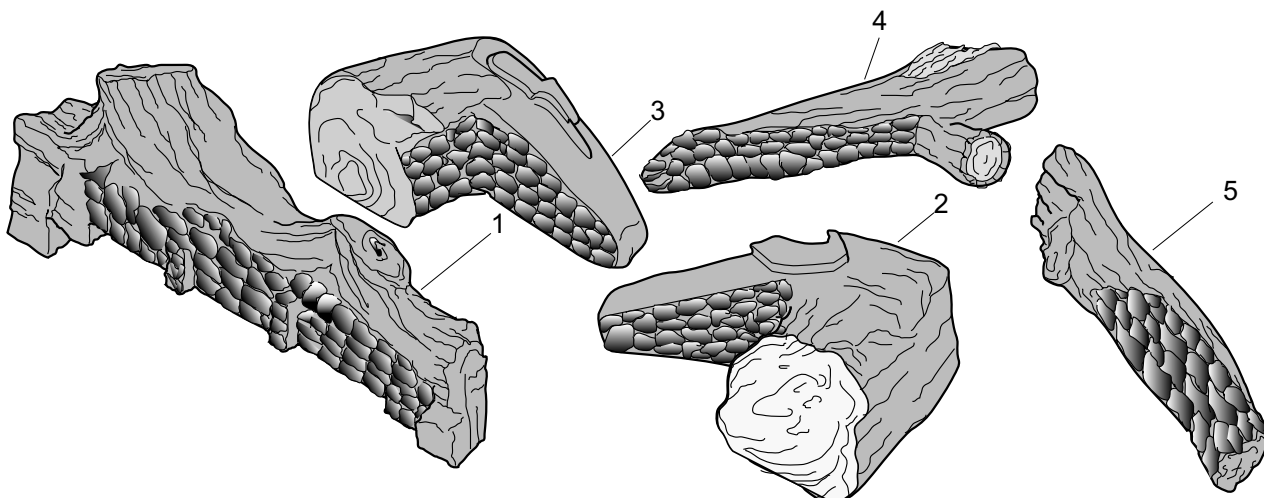

ILLUSTRATED PARTS LISTS

ADDITIONAL ACCESSORIES

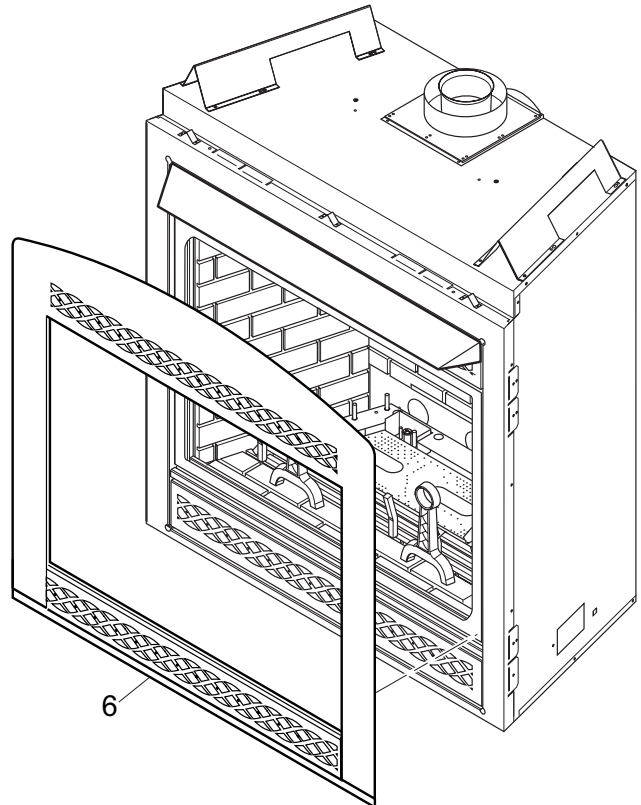
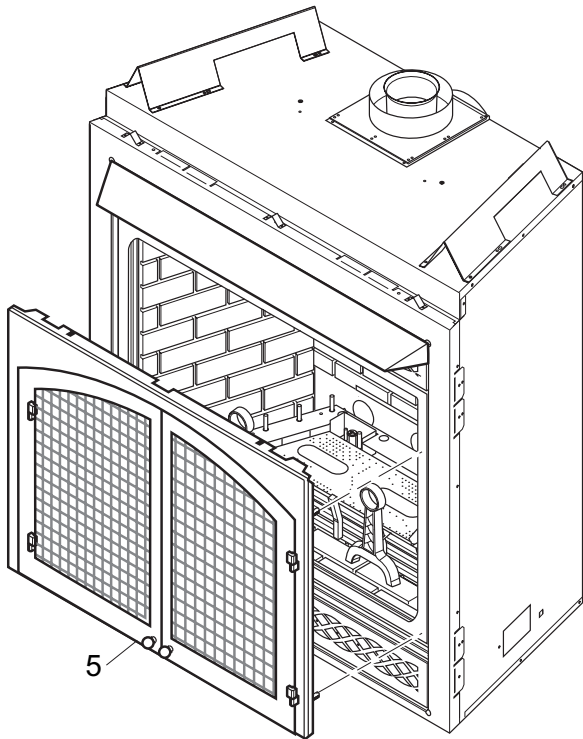
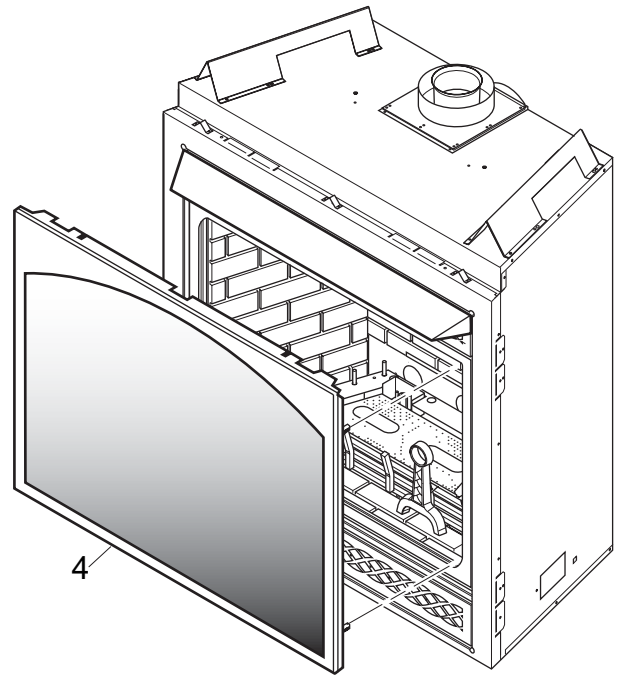
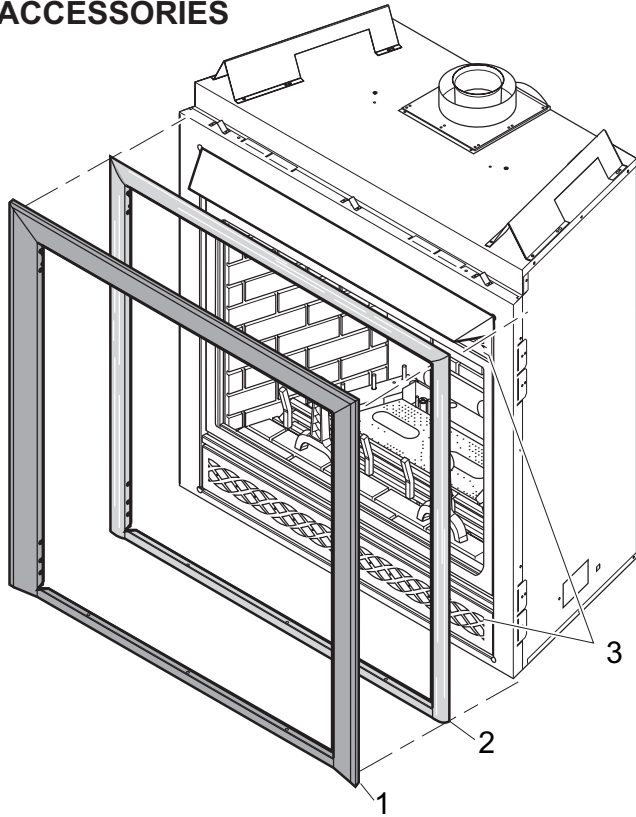

ILLUSTRATED PARTS LISTS

ADDITIONAL ACCESSORIES/FIELD INSTALLED OPTIONS AVAILABLE

Item	Description	Qty	SDV500	SDV600
1	Metal Trim - Brass	1	BRMTK36	BRMTK42
1	Metal Trim - Pewter	1	BLMTK36	PWMTK42
1	Metal Trim - Black	1	PWMTK36	BLMTK42
2	Curved Design - Black	1	BLMTK36	BLMTK42
2	Curved Design - Brass	1	BRMTK36	BRMTK42
2	Curved Design - Pewter	1	PWMTK36	PWMTK42
3	Filigree - Gold	1	D36FPG	D42FPG
3	Filigree - Pewter	1	D36FPP	D42FPP
4	Arched Screen Frame - Black	1	SDV500ASFB	SDV600ASFB
4	Arched Screen Frame - Gold	1	SDV500ASFG	SDV600ASFG
4	Arched Screen Frame - Brushed Pewter	1	SDV500ASFP	SDV600ASFP
5	Cabinet Door Frame - Black	1	SDV500CDFB	SDV600CDFB
5	Cabinet Door Frame - Gold	1	SDV500CDFG	SDV600CDFG
5	Cabinet Door Frame - Brushed Pewter	1	SDV500CDFP	SDV600CDFP
5	Cabinet Door with Screen - Black	1	SDV500CDB	SDV600CDB
5	Cabinet Door with Screen - Gold	1	SDV500CDG	SDV600CDG
5	Cabinet door with Screen - Brushed Pewter	1	SDV500CDP	SDV600CDP
6	Arched Front with Lower Control Door - Black	1	SDV500AFB	SDV600AFB
6	Arched Front with Lower Control Door - Gold	1	SDV500AFG	SDV600AFG
6	Arched Front with Lower Control Door - Brushed Pewter	1	SDV500AFP	SDV500AFP
Accessories/Field Installed Options Available but Not Shown				
	Oak Wall Surround with Honey Oak Finish	1	WS500F-O	
	Birch Surround with Dark Cherry Finish	1	WS500F-C	
	Oak Hearth with Honey Oak Finish	1	WH500F-O	
	Birch Hearth with Dark Cherry Finish	1	WH500F-C	

ILLUSTRATED PARTS LISTS

STANDING PILOT — MILLIVOLT CONTROL

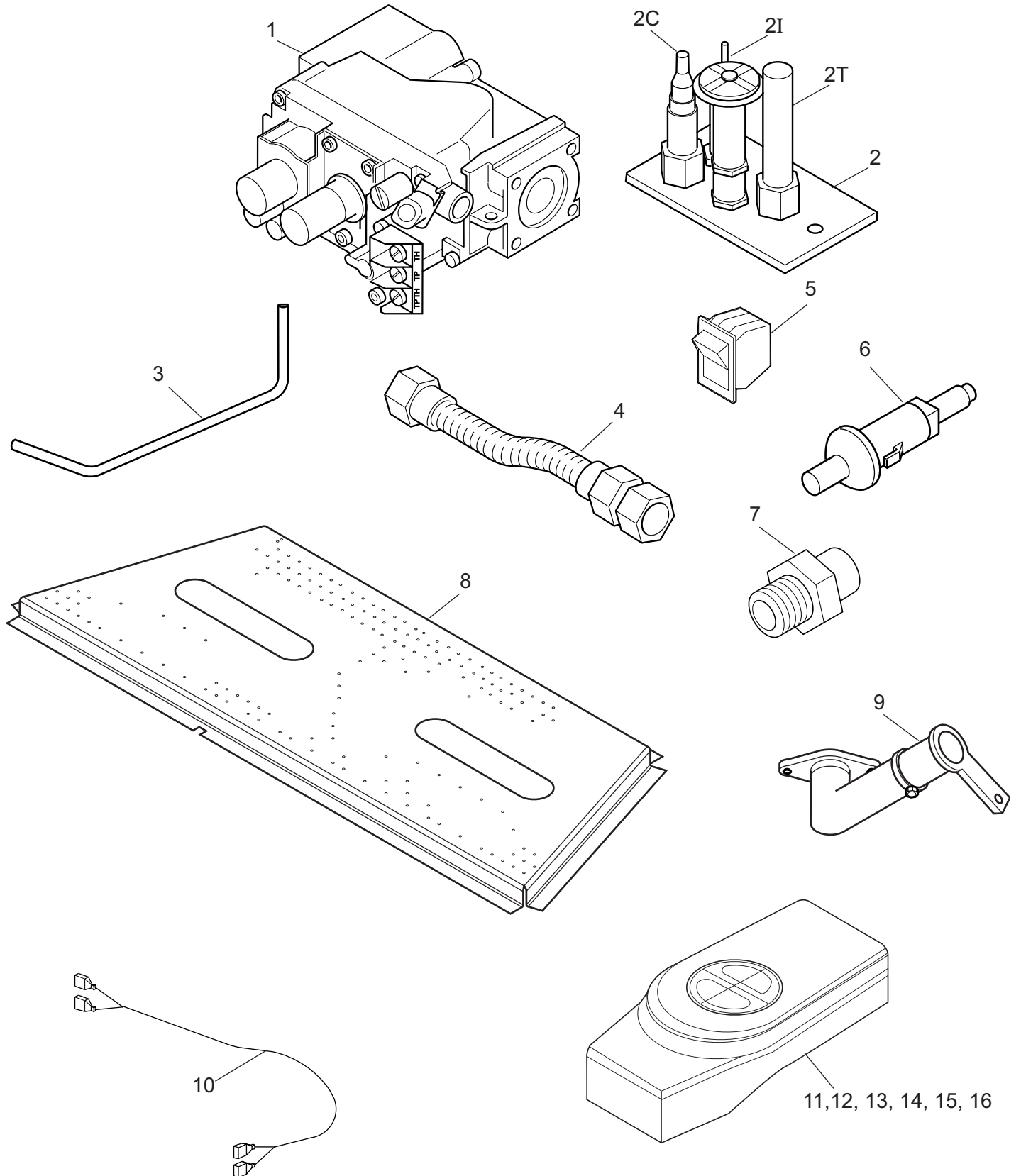

ILLUSTRATED PARTS LISTS

STANDING PILOT – MILLIVOLT CONTROL

Item	Description	Qty	SDV500NV	SDV500PV	SDV600NV	SDV600PV
1	Gas Valve Assembly	1	37D0117	37D0118	37D0117	37D0118
2	Pilot Assembly	1	37D0018	37D0019	37D0018	37D0019
2C	Replacement Thermocouple	1	37D1067	37D1067	37D1067	37D1067
2I	Replacement Igniter and Wire	1	37D1069	37D1069	37D1069	37D1069
2T	Replacement Thermopile	1	37D1068	37D1068	37D1068	37D1068
3	Burner Tube	1	54D0194	54D0194	54D0194	54D0194
4	Flexhose with Shutoff Valve	1	23D6046	23D6046	23D6046	23D6046
5	Rocker Switch	1	41D0048	41D0048	41D0048	41D0048
6	Piezo Igniter	1	14D0503	14D0503	14D0503	14D0503
7	Injector	1	56D0114	56D0113	56D0614	62D3003
8	Burner Assembly	1	54D0378	54D0378	54D0378	54D0378
9	Venturi	1	45D0600	45D0600	45D0600	45D0600
10	Wire Assembly	1	44D0500	44D0500	44D0500	44D0500
10	Wire Assembly	1	44D0501	44D0501	44D0501	44D0501
Accessories						
11	Thermostatic Remote Control	1	RCT/TRC	RCT/TRC	RCT/TRC	RCT/TRC
12	Remote Control On/Off	1	RCM/MRC	RCM/MRC	RCM/MRC	RCM/MRC
13	Remote Control Basic	1	RCB/RCBE	RCB/RCBE	RCB/RCBE	RCB/RCBE
14	Wireless Wall Thermostat	1	WWTD/WWTA	WWTD/WWTA	WWTD/WWTA	WWTD/WWTA
15	Wall Switch Kit	1	MVWS	MVWS	MVWS	MVWS
16	Wall Thermostat Kit	1	MVWTS	MVWTS	MVWTS	MVWTS
Conversion Kit (Not Shown)						
	500 Conversion NG to LPG	1	SCK500CKP	—	—	—
	500 Conversion LPG to NG	1	—	SCK500CKN	—	—
	600 Conversion NG to LP	1	—	—	SCK500CKP	—
	600 Conversion LP to NG	1	—	—	—	SCK500CKN

ILLUSTRATED PARTS LISTS

ELECTRONIC IGNITION

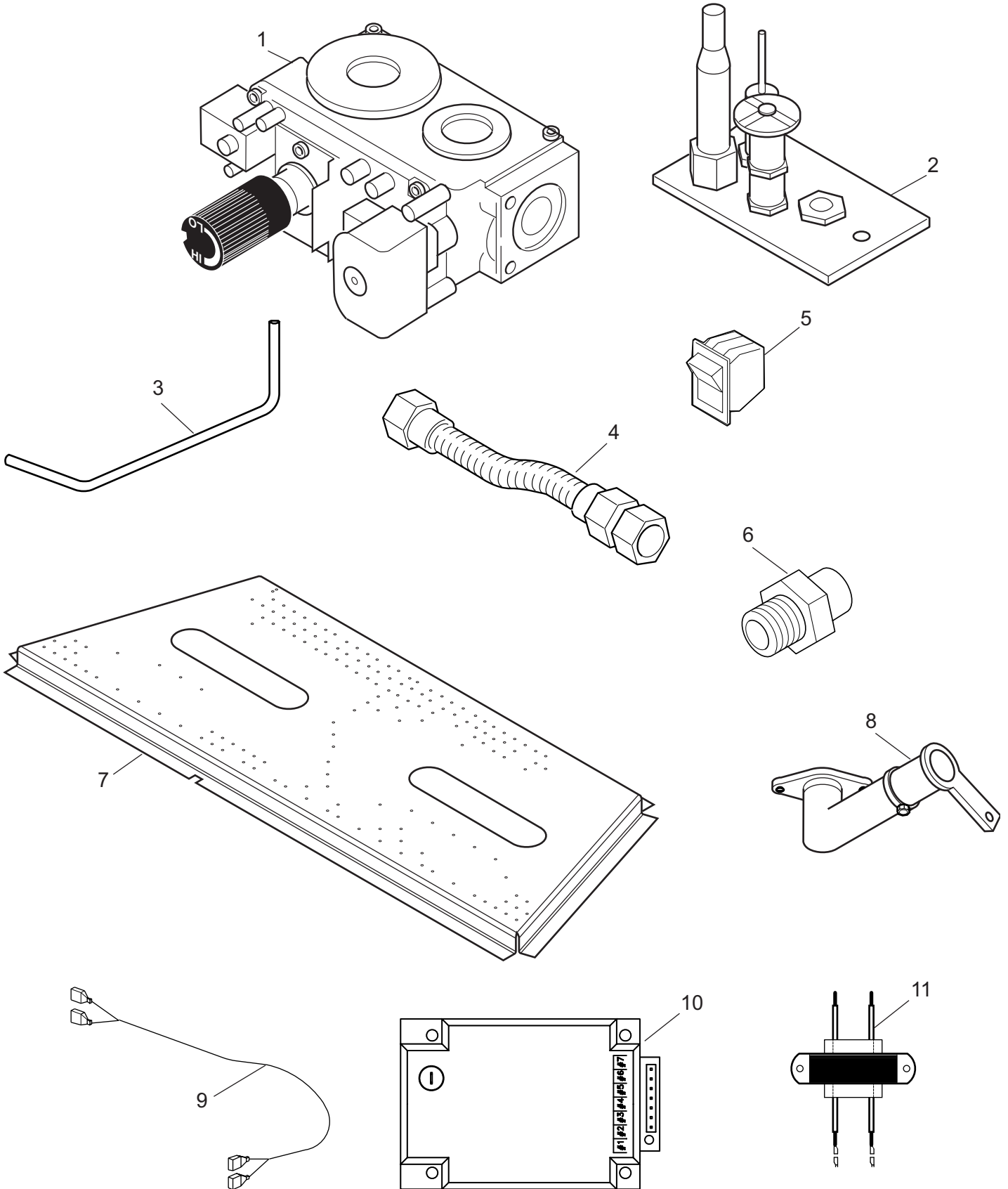

ILLUSTRATED PARTS LISTS

ELECTRONIC IGNITION

Item	Description	Qty	SDV500	SDV600
1	Gas Valve Assembly	1	37D0016	37D0017
2	Pilot Assembly	1	37D0020	37D0021
3	Burner Tube	1	54D0288	54D0288
4	Flexhose with Shutoff Valve	1	23D6046	23D6046
5	Rocker Switch	1	41D0048	41D0048
6	Injector	1	56D0113/114	56D0614/62D3003
7	Burner Assembly	1	56D0136	56D0136
8	Venturi	1	45D0059	45D0059
9	Wire Assembly	1	54D2007	54D2007
10	Ignition Module	1	37D0325	37D0325
11	Transformer	1	37D0027	37D0027

TROUBLESHOOTING

STANDING PILOT IGNITION

SYMPTOM	POSSIBLE CAUSE	ACTION
1. Spark ignitor will not light pilot after repeated triggering of piezo.	A. Wire disconnected. B. Defective ignitor. C. No gas or low gas pressure. D. No Propane/LPG in tank	A. Open door and check to make sure wire is connected to ignitor. B. Check for spark at electrode and pilot. If no spark and electrode wire is properly connected, replace pilot assembly. C. Check remote/manual shut off valve from fireplace. Low pressure can be caused by bent lines, restricted lines, low pressure line pressure. Consult with plumber or gas supplier. D. Check Propane/LPG tank. Refill tank.
2. Pilot will not stay lit after carefully following lighting instructions.	A. Defective thermocouple B. Defective valve	A. Check that thermocouple flame impinges on thermocouple. Clean and/or adjust pilot for maximum flame impingement. Ensure that the thermocouple connection at the gas valve is fully inserted and tight. Disconnect the thermocouple from the valve, place one millivolt lead wire on the tip of the thermocouple and the other meter lead wire on the thermocouple copper lead. Start the pilot and hold the valve knob in. If the millivolt reading is less than 15 mV, replace pilot assembly. B. If thermocouple is producing more than 15 mV, replace faulty valve.
3. Pilot burning, valve knob turned to "ON", switch is turned to "ON" or "RS", but burner will not ignite.	A. Defective switch, wall switch, remote control or wire B. Pilot flame too small C. Defective or malfunctioning thermopile D. Defective valve	A. Check switch and wire for proper connection. Place jumper wires across terminals of switch. If burner comes on, replace defective switch. If the switch is OK, repeat the same procedure on remote control. If burner comes on, replace remote control. Place jumper wire across wire at gas valves (terminals marked TH and TP/TH). If burner comes on, wires are faulty or connections are bad. Replace wire. B. If pilot flame is not close enough to the thermopile, adjust pilot flame. C. Check thermopile wire connections to make sure all are tight and that the thermopile is fully inserted into pilot assembly. Check thermopile with a millivolt meter. Connect leads to TP and TP/TH terminals on the control valve. If meter reading is below 325 mV, replace pilot assembly. D. Turn valve knob to "On" and switch to "ON." Take a reading at the thermopile leads (TP & TP/TH) on the valve. If the meter reads greater than 175 mV and the burner does not light, replace defective valve.
4. Frequent pilot outage problem.	A. Pilot flame may be too high or too low, causing pilot safety to drop out	A. Clean and adjust the pilot flame for maximum flame impingement on thermocouple.
5. The pilot and main burner extinguish while in operation	A. Inner vent pipe leaking exhaust gases back into system B. Horizontal vent improperly pitched C. Improper vent cap installation	A. Check for flue product leak. Replace defective pipe section. B. Check horizontal-venting piping is running upward 1/4" per foot. Do not run the pipe level or downward. C. Check for proper installation and freedom from debris or blockage

ELECTRONIC IGNITION START

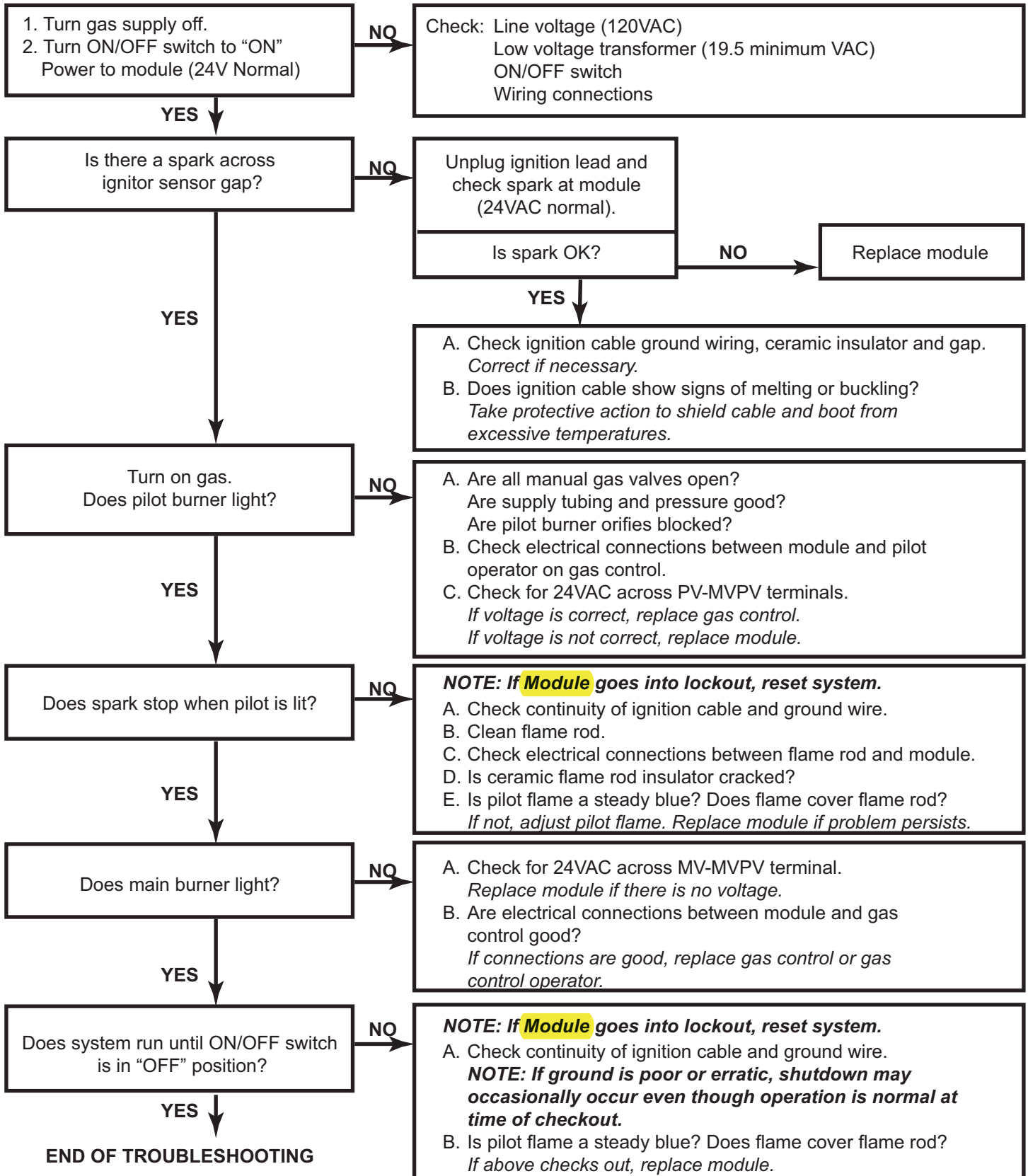

TROUBLESHOOTING

GENERAL TROUBLESHOOTING

SYMPTOM	POSSIBLE CAUSE	ACTION
1. Glass Soots	A. Flame impingement on logs	A. Install log set per the instructions Inspect the injector and air intake area. Make sure this area does not have any blockage from debris and clean. Check gas supply.
2. Flame burn blue and lifts off burner (ghosting)	A. Insufficient oxygen being supplied	A. Ensure that the vent cap is installed properly and free of debris. Ensure that the vent system joints are tight and have no leaks. Ensure that no debris has been blocking the inner air intake at the bottom back of the combustion chamber. Ensure that the glass is properly secure and latch.

MASSACHUSETTS RESIDENTS ONLY: PLEASE READ AND FOLLOW THESE SPECIAL REQUIREMENTS

NOTE REGARDING VENTED PRODUCTS

This product must be installed by a licensed plumber or gas fitter when installed within the Commonwealth of Massachusetts.

Any residence with a direct vent product must have a CO detector installed in the residence.

Installation of the fireplace or vented gas log in the State of Massachusetts requires the damper to be permanently removed or welded in the fully open position.

In addition, a naturally vented gas log may not be installed in a bedroom or bathroom in the State of Massachusetts.

Flex line installation must not exceed 36 inches and must have a T shutoff valve.

NOTE REGARDING VENT FREE PRODUCTS

This product must be installed by a licensed plumber or gas fitter when installed within the Commonwealth of Massachusetts.

In addition, vent free products may not be installed in a bedroom or bathroom regardless of size or type in the State of Massachusetts.

Flex line installation must not exceed 36 inches and must have a T shutoff valve.

CARBON MONOXIDE DETECTOR REQUIREMENTS

(2) Revise 10.8.3 by adding the following additional requirements:

- (a) For all side wall horizontally vented gas fueled equipment installed in every dwelling, building or structure used in whole or in part for residential purposes, including those owned or operated by the Commonwealth and where the side wall exhaust vent termination is less than seven (7) feet above finished grade in the area of the venting, including but not limited to decks and porches, the following requirements shall be satisfied:
1. **INSTALLATION OF CARBON MONOXIDE DETECTORS.** At the time of installation of the side wall horizontal vented gas fueled equipment, the installing plumber or gasfitter shall observe that a hard wired carbon monoxide detector with an alarm and battery back-up is installed on the floor level where the gas equipment is to be installed. In addition, the installing plumber or gasfitter shall observe that a battery operated or hard wired carbon monoxide detector with an alarm is installed on each additional level of the dwelling, building or structure served by the side wall horizontal vented gas fueled equipment. It shall be the responsibility of the property owner to secure the services of qualified licensed professionals for the installation of hard wired carbon monoxide detectors
 - a. In the event that the side wall horizontally vented gas fueled equipment is installed in a crawl space or an attic, the hard wired carbon monoxide detector with alarm and battery back-up may be installed on the next adjacent floor level.
 - b. In the event that the requirements of this subdivision can not be met at the time of completion of installation, the owner shall have a period of thirty (30) days to comply with the above requirements; provided, however, that during said thirty (30) day period, a battery operated carbon monoxide detector with an alarm shall be installed.
-

SPECIAL REQUIREMENTS CONTINUED

2. APPROVED CARBON MONOXIDE DETECTORS. Each carbon monoxide detector as required in accordance with the above provisions shall comply with NFPA 720 and be ANSI/UL 2034 listed and IAS certified.
 3. SIGNAGE. A metal or plastic identification plate shall be permanently mounted to the exterior of the building at a minimum height of eight (8) feet above grade directly in line with the exhaust vent terminal for the horizontally vented gas fueled heating appliance or equipment. The sign shall read, in print size no less than one-half (1/2) inch in size, **“GAS VENT DIRECTLY BELOW. KEEP CLEAR OF ALL OBSTRUCTIONS.”**
 4. INSPECTION. The state or local gas inspector of the side wall horizontally vented gas fueled equipment shall not approve the installation unless, upon inspection, the inspector observes carbon monoxide detectors and signage installed in accordance with the provisions of 248 CMR 5.08(2)(a)1 through 4.
- (b) EXEMPTIONS: The following equipment is exempt from 248 CMR 5.08(2)(a)1 through 4:
1. The equipment listed in Chapter 10 entitled “Equipment Not Required To Be Vented” in the most current edition of NFPA 54 as adopted by the Board; and
 2. Product Approved side wall horizontally vented gas fueled equipment installed in a room or structure separate from the dwelling, building or structure used in whole or in part for residential purposes.
- (c) MANUFACTURER REQUIREMENTS - GAS EQUIPMENT VENTING SYSTEM PROVIDED. When the manufacturer of Product Approved side wall horizontally vented gas equipment provides a venting system design or venting system components with the equipment, the instructions provided by the manufacturer for installation of the equipment and the venting system shall include:
1. Detailed instructions for the installation of the venting system design or the venting system components; and
 2. A complete parts list for the venting system design or venting system.
- (d) MANUFACTURER REQUIREMENTS - GAS EQUIPMENT VENTING SYSTEM NOT PROVIDED. When the manufacturer of a Product Approved side wall horizontally vented gas fueled equipment does not provide the parts for venting the flue gases, but identifies “special venting systems,” the following requirements shall be satisfied by the manufacturer:
1. The referenced “special venting system” instructions shall be included with the appliance or equipment installation instructions; and
 2. The “special venting systems” shall be Product Approved by the Board, and the instructions for that system shall include a parts list and detailed installation instructions.
- (e) A copy of all installation instructions for all Product Approved side wall horizontally vented gas fueled equipment, all venting instructions, all parts lists for venting instructions, and/or all venting design instructions shall remain with the appliance or equipment at the completion of the installation.
-

LIMITED LIFETIME WARRANTY POLICY

LIFETIME WARRANTY

The following components are warranted for life to the original owner, subject to proof of purchase: Firebox, Combustion Chamber, Heat Exchanger, Grate and Stainless Steel Burners.

FIVE YEAR WARRANTY

The following components are warranted five (5) years to the original owner, subject of proof of purchase: Ceramic Fiber Logs.

BASIC WARRANTY

Monessen Hearth Systems (MHS) warrants the components and materials in your gas appliance to be free from manufacturing and material defects for a period of two years from date of installation. After installation, if any of the components manufactured by MHS in the appliance are found to be defective in materials or workmanship, (MHS) will, at its option, replace or repair the defective components at no charge to the original owner. MHS will also pay for reasonable labor costs incurred in replacing or repairing such components for a period of two years from date of installation. Any products presented for warranty repair must be accompanied by a dated proof of purchase.

This Limited Lifetime Warranty will be void if the appliance is not installed by a qualified installer in accordance with the installation instructions. The Limited Lifetime Warranty will also be void if the appliance is not operated and maintained according to the operating instructions supplied with the appliance, and does not extend to (1) firebox/burner assembly damage by accident, neglect, misuse, abuse, alterations, negligence of others, including the installation thereof by unqualified installers, (2) the costs of removal, reinstallation or transportation of defective parts on the appliance, or (3) incidental or consequential damage. All service work must be performed by an authorized service representative.

This warranty is expressly in lieu of other warranties, express or implied, including the warranty of merchantability of fitness for purpose and of all other obligations or liabilities. MHS does not assume for it any other obligations or liabilities in connection with sale or use of the appliance. It states that do not allow limitations on how long an implied warranty lasts, or do not allow exclusion of indirect damage, those limitations of exclusions may not apply to you. You may also have additional rights not covered in the Limited Lifetime Warranty.

MHS reserves the right to investigate any and all the claims against the Limited Lifetime Warranty and decide upon method of settlement.

For information about this warranty, contact:

**Technical Services
Monessen Hearth Systems
149 Cleveland Drive
Paris, Kentucky 40361**