



Spare Parts Catalogue

Dishwashers \ ASKO 5000 XL ADA Compliant Series
Type: DW70.1

Model: D5122 XL US Sense Black

Prod. No: 107512282

October 29th 2009

ASKO Appliances Inc.

4001 E Plano Parkway #1004001 E Plano Parkway #100
Plano, Texas 75074

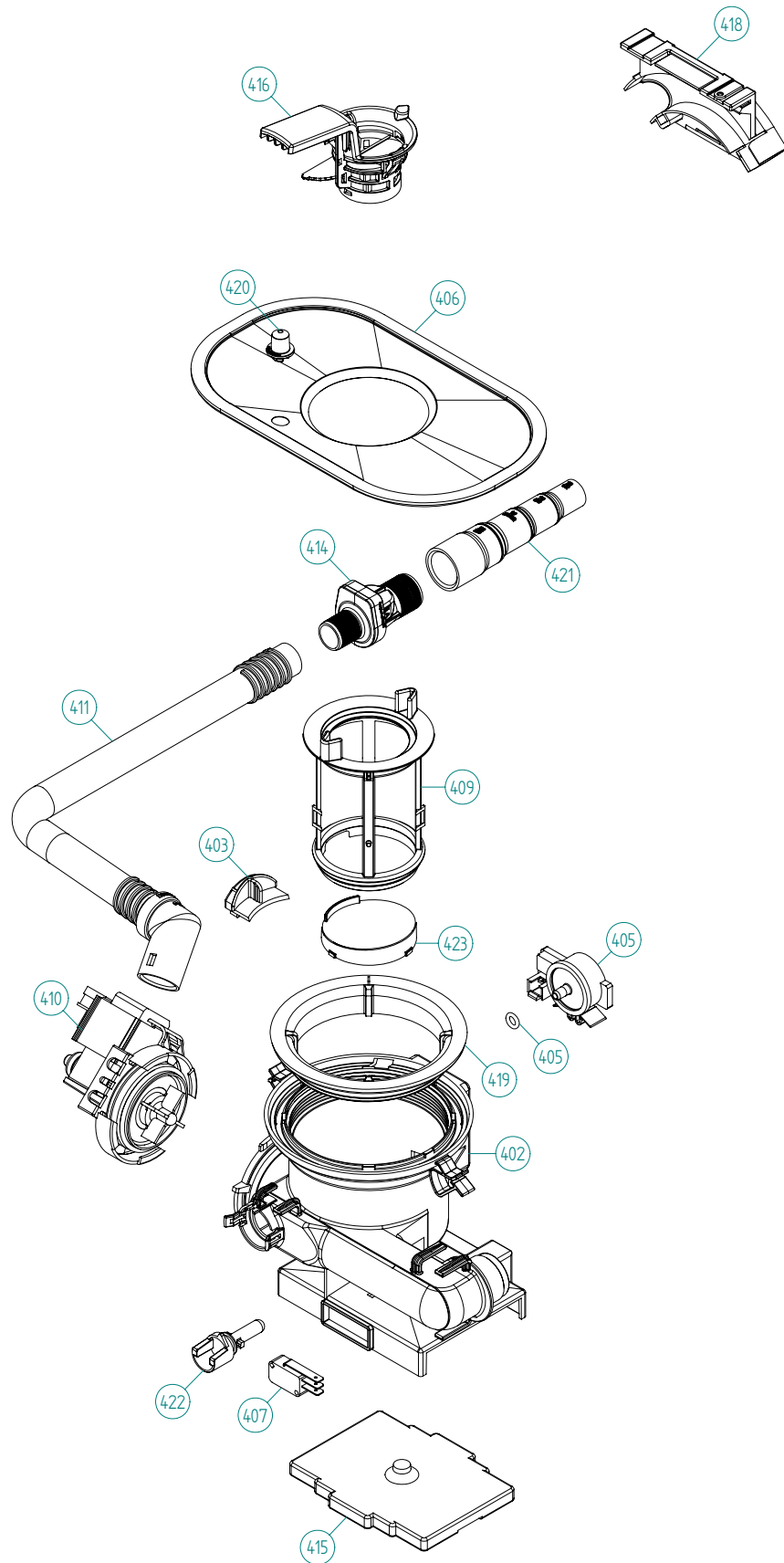

Bottom well and related parts

ASKO, D5122 XL US - Sense Black (DW70.1)

Pos	Spare part No.	Description	Qty	Comment
402	8801403	KIT BOTTOM WELL PRES.SENS.DW70	1 Pc's	
402-a	8073002	ORing	1 Pc's	
403	8078033	Rinse Cap Bottom Well - Yellow	1 Pc's	
405	8073839	Pressure Sensor	1 Pc's	
405-a	8074040	O-Ring	1 Pc's	
406	8074364	Strainer DW20	1 Pc's	
407	8073835	Microswitch Float	1 Pc's	
409	8078038-77	Pipe Filter DW70	1 Pc's	
410	8078089	Drain Pump 120V 60Hz	1 Pc's	
411	8079693	Outlet Hose w/o Return Valve	1 Pc's	
414	8801248	Check Valve Kit	1 Pc's	
414-a	8052239	Hose Clamp	1 Pc's	
414-b	8053642	Hose Clamp	1 Pc's	
415	8078025	Float	1 Pc's	
416	8078039-77	Strainer Basket Grey	1 Pc's	
418	8072528-77	Holder Outlet Hose	1 Pc's	
418-a	8053642	Hose Clamp	1 Pc's	
418-b	8052239	Hose Clamp	1 Pc's	
418-c	33700450	Cable Strip	1 Pc's	
418-d	8902072	Screw	1 Pc's	
419	8072848	Lockring Bottom Well	1 Pc's	
420	8074760-77	Ventilator	1 Pc's	
421	8075321	End Cuff	1 Pc's	
422	8078096	Thermistor	1 Pc's	
423	8080827	BOTTOM LID TUBE FILTER	1 Pc's	
426	8078024	SEALING NON RETURN VALVE	1 Pc's	

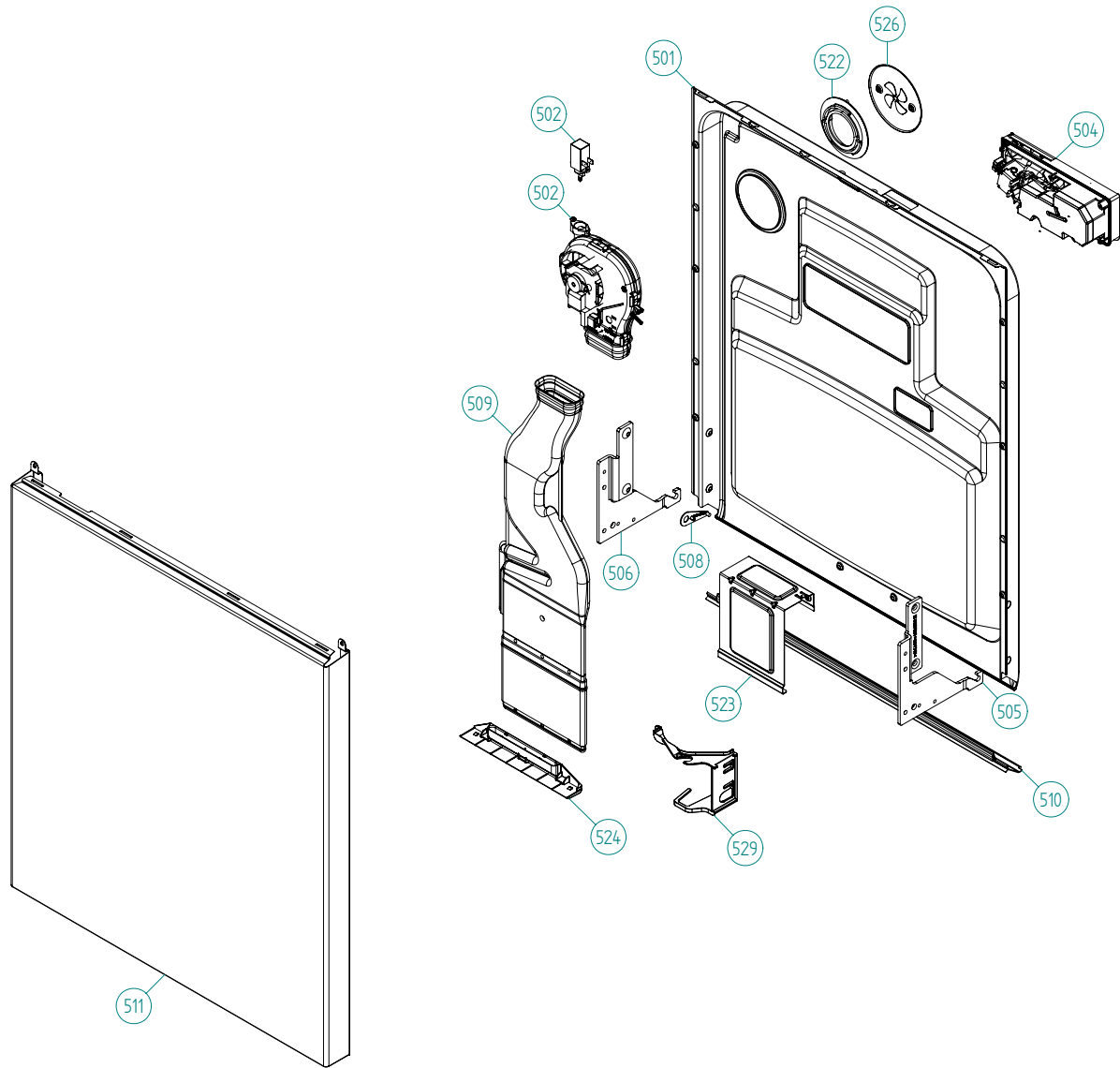

Inner door, panel and related parts

ASKO, D5122 XL US - Sense Black (DW70.1)

Pos	Spare part No.	Description	Qty	Comment
501	8083212-M	INNERDOOR FAN	1 Pc's	
502	8084419	FAN COMPL. 120V 60HZ	1 Pc's	
502-a	8058501	ORing Turbo Fan Dry 05/06 DW	1 Pc's	
502-b	8052778	WAX MOTOR DW 05/06	1 Pc's	
504	8801343-77	KIT Combi Dispenser 120V	1 Pc's	
504-a	8071916	SEAL,DET.COMPLID repl by 8071918	1 Pc's	
504-b	8071917	CAP RINSE AGENT	1 Pc's	
504-c	8071918	Detergent Lid Complete	1 Pc's	
504-d	8072288	Sealing Strip Combi Disp.	1 Pc's	
504-f	8902087	Screw Plastic Housing 20 Torx	6 Pc's	
505	8078004	Hinge Right DW70	1 Pc's	
506	8078005	Hinge Left DW70	1 Pc's	
507	8057530	Screw hinge 05	2 Pc's	
507-a	33500262	Nut Term Block	2 Pc's	
508	8057948	Slide washer hinge bearing 05	2 Pc's	
509	8078040	Air Channel DW70	1 Pc's	
510	8060254	Lower SealInner Door 05/06 DW	1 Pc's	
511	8076933-29	DOOR OUTER PART XL REINFOR. BL	1 Pc's	
511-a	8900646	Screw 20 Torx SS	6 Pc's	
522	8057964	Locking ring turbo fan 05	1 Pc's	
522-a	8902085	Screw 20T for Plastic	2 Pc's	
523	8057984	Push Button Grey 1706/1716 DW	1 Pc's	
523-a	8900646	Screw 20 Torx SS	2 Pc's	
523-b	8902357	Screw	2 Pc's	
524	8078041-33	NOZZLE AIR DUCT	1 Pc's	
526	8058484	SS Coverplate Turbo Fan DW	1 Pc's	
526-a	8902085	Screw 20T for Plastic	2 Pc's	
529	8074278	Bracket for harness	1 Pc's	

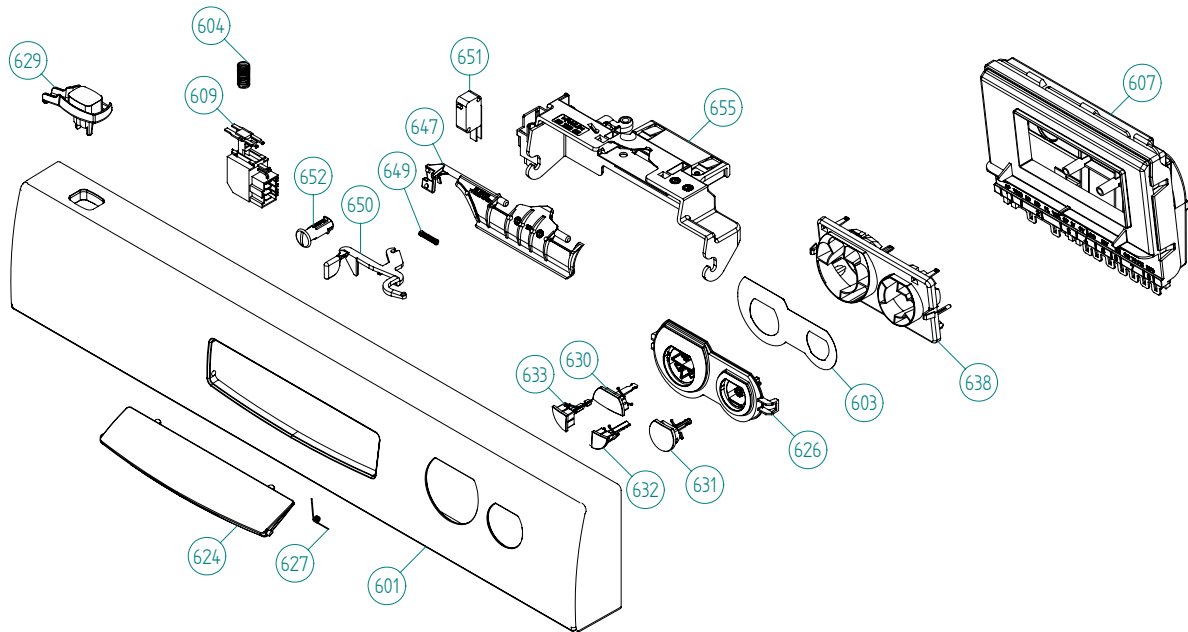

Control panel and related parts

ASKO, D5122 XL US - Sense Black (DW70.1)

Pos	Spare part No.	Description	Qty	Comment
601	8082701-69-UL	Control Panel D5122XXL	1 Pc's	
602	8078191	program info label 3122	1 Pc's	
602	8078206	program info lable FR	1 Pc's	
603	8074957	Decor Plate Graphic	1 Pc's	
604	8074277	SPRING MAIN SWITCH	1 Pc's	
607	8801362	Control Unit DW70.1	1 Pc's	
609	8073782	MAIN PUSH SWITCH	1 Pc's	
611	8075742	CABLE SET DOOR WITH FAN	1 Pc's	
614	8078068	CABLE SET CIRC.PUMP INL.VALVE	1 Pc's	
616	8078067	CABLE SET FLOW & PRESSURE	1 Pc's	
618	8078070	CABLE SET POWER	1 Pc's	
619	8078066	CABLE SET THERMIST DW70.1 .C	1 Pc's	
622	8078063	CABLE SET DRAIN	1 Pc's	
624	8073470-69	COVER FOR HANDLE BLACK	1 Pc's	
626	8074000	Lens DW320	1 Pc's	
627	8074464	SPRING FOR LID HANDLE	1 Pc's	
629	8075078-69	Push Button Main Switch Graphi	1 Pc's	
630	8075082-69	Push Button Prog	1 Pc's	
631	8075081-69	Push Button Start/Stop	1 Pc's	
632	8075084-69	Push Button Start/Stop	1 Pc's	
633	8075083-69	Push Button Left Opt	1 Pc's	
638	8074008	Light Guide	1 Pc's	
647	8072906	Catch Handle	1 Pc's	
649	8075790	Spring Door Lock Handle	1 Pc's	
649	8072908	SPRING LOCK	1 Pc's	
650	8072907	Control Arm Safety Catch	1 Pc's	
651	8073836	MICROSWITCH DOOR	1 Pc's	
652	8057545	Rotary catch child safety 05	1 Pc's	
655	8072905	Protection Catch	1 Pc's	
655-a	8902085	Screw 20T for Plastic	2 Pc's	
690	8084452	INSTRUCTIONS D5122 USA XL ENG	1 Pc's	
690	8084453	INSTRUCTIONS D5122 USA XL FR	1 Pc's	

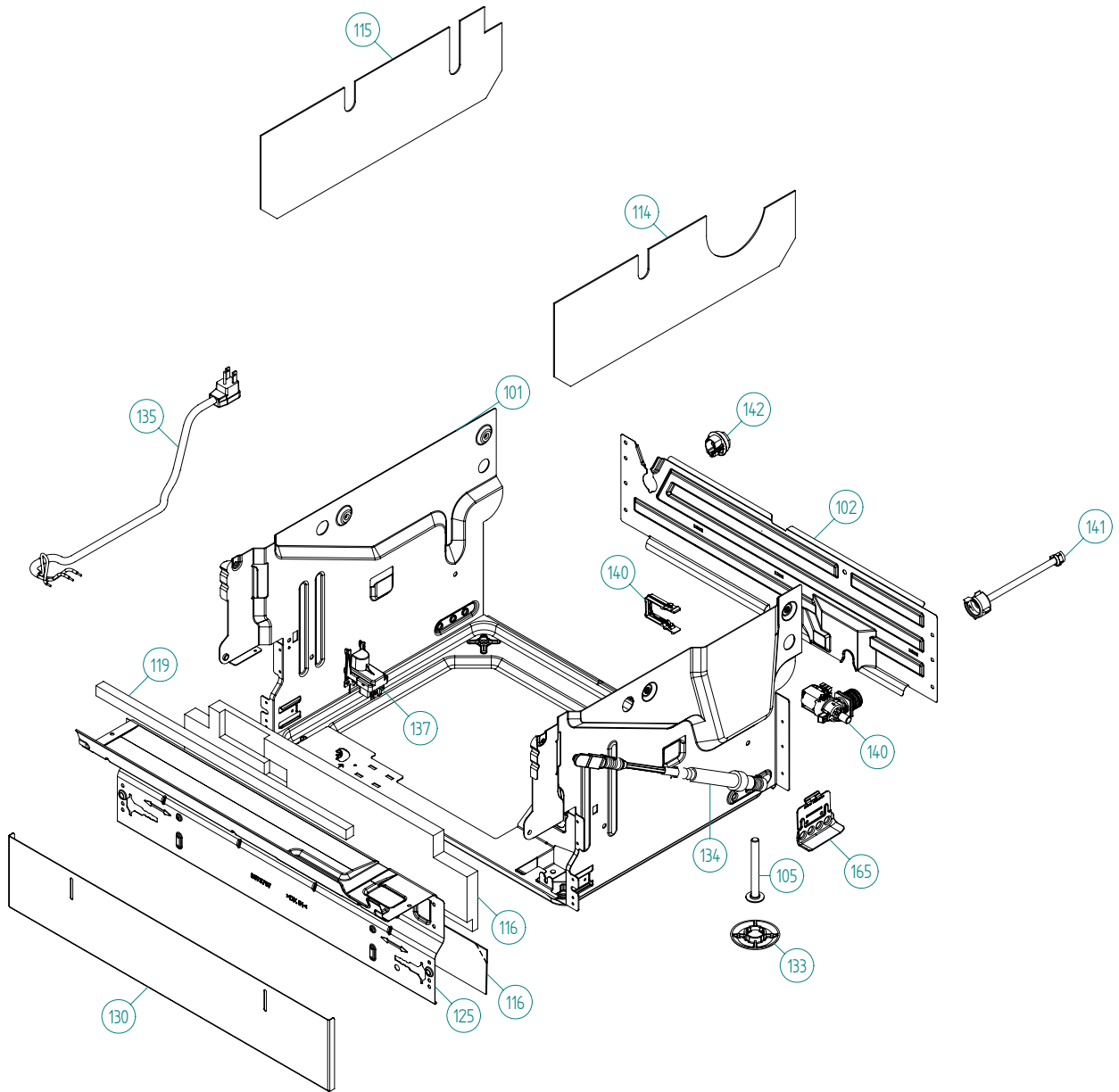

Base and related parts

ASKO, D5122 XL US - Sense Black (DW70.1)

Pos	Spare part No.	Description	Qty	Comment
101	8801387	BOTTOM OUTER COMPL.	1 Pc's	
102	8078006	REAR PANEL	1 Pc's	
105	8074877	Foot	4 Pc's	
114	8078109	SOUND ABSORP. SELF AD. RIGHT	1 Pc's	
115	8078108	SOUND ABSORP. SELF AD. LEFT	1 Pc's	
116	8082272	SOUND ABSORPT PROTECTIVE PLATE	1 Pc's	
116	8078114	SOUND ABSORBENT GUARD PLATE	1 Pc's	
119	8078122	SOUND ABSORPTION PROFILE	1 Pc's	
125	8078007-29	GUARD PLATE FLANGED BLACK	1 Pc's	
130	8079572-29	KICK-PLATE FIXED DEPTH BLACK	1 Pc's	
133	8051957	Glide Foot	2 Pc's	
134	8079528	Door Spring-DW70-Yellow	2 Pc's	
135	8083262	CORD SET 15A AMERICA	1 Pc's	
136-a	8902131	Screw	1 Pc's	
137	8083041	FILTER WITH SCREWPLINT	1 Pc's	
137-a	8901097	Screw Terminal	1 Pc's	
140	8801376	KIT INL.VALVE/LOCKARM SING120V	1 Pc's	
140-a	8079597	LOCK ARM INLET VALVE	1 Pc's	
141	8079522	PEX Inlet hose DW	1 Pc's	
142	8006948	Grommet	1 Pc's	
164	8079597	LOCK ARM INLET VALVE	1 Pc's	
165	8078013	DOOR SPRING HOLDER	1 Pc's	
165-a	8902362	SCREW RTK ST 4,2X9,5 FZB WAX.	1 Pc's	

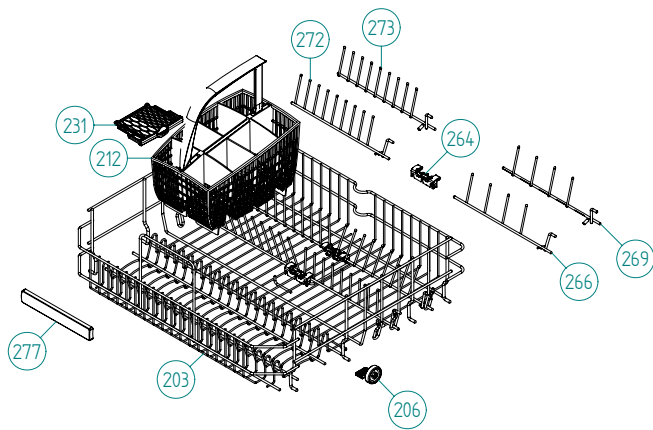
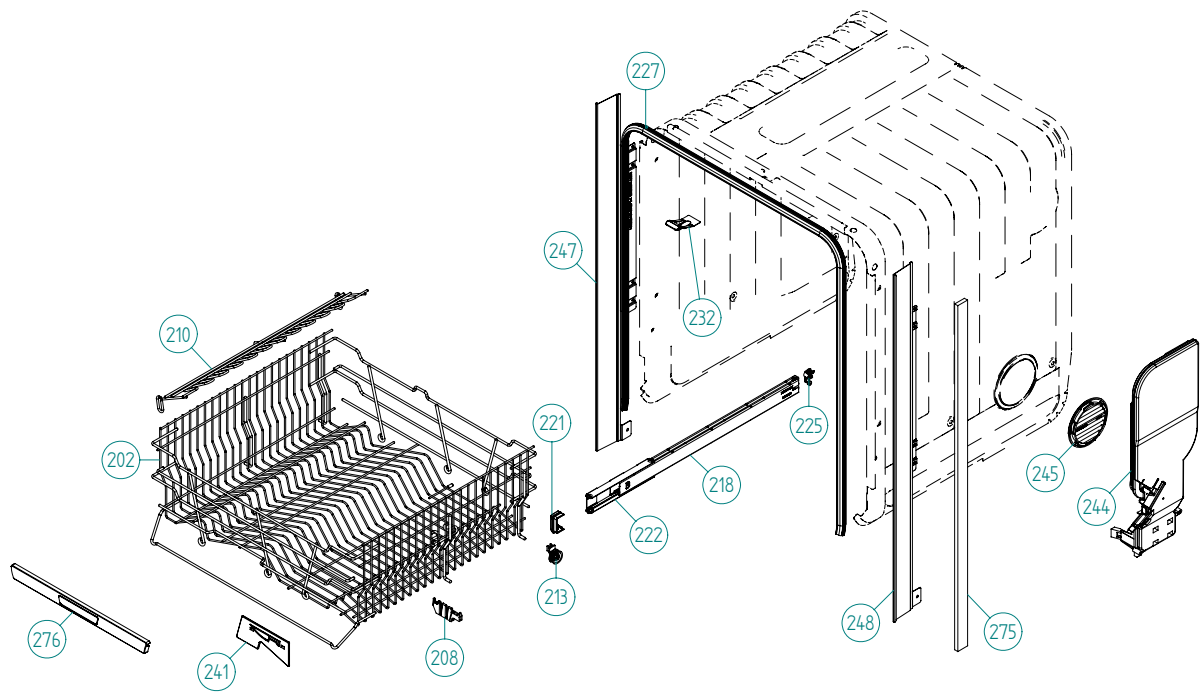

Baskets and related parts

ASKO, D5122 XL US - Sense Black (DW70.1)

Pos	Spare part No.	Description	Qty	Comment
201	8057056	-	1 Pc's	Not a spare part
202	8801315-36	UPPER BASKET EXCL. CPL D.GREY	1 Pc's	
203	8801316-36	LOWER BASKET EXCL D.GREY 07	1 Pc's	New design
206	8079257-77	WHEEL FOR LOW DISHW BASKET CPL	8 Pc's	New design
208	8071214-77	Knife Holder 05/06 DW	2 Pc's	
210	8071337-36	Cup Shelf Wine Glass 05/06 DW	2 Pc's	
212	8801317-77	CUTLERY BASKET COMPL. 07	1 Pc's	New design
213	8058498-77	Upper Basket Wheel	4 Pc's	
218	8057052	DW Upper Basket Guide Rail	2 Pc's	
220	8057978-77	DW Rail Stop - Back Grey	2 Pc's	
221	8057979-77	Rack Stop Grey 05/06 DW	2 Pc's	
222	8801349-77	KIT BALL HOLDER INCL. BALLS	1 Pc's	
225	8057978-77	DW Rail Stop - Back Grey	2 Pc's	
227	8057489-E	Door strip 3000xl	1 Pc's	
231	8079251-77	DOOR CUTLERYBASKET UL4	1 Pc's	New design
232	8801240	Lock Catch incl Screw&Nut	1 Pc's	
241	8057506-77	Knife Stop	1 Pc's	
244	8078300	AIRBREAK STD. DW70 UL4	1 Pc's	
245	8057536-77	Lockring Airbreak Gray	1 Pc's	
247	8074342-E-29	TRIM STRIP LEFT USA 86CM BLACK	1 Pc's	
247-a	8900646	Screw 20 Torx SS	2 Pc's	
248	8074343-E-29	TRIM STRIP RIGHT USA 86CM BL.	1 Pc's	
248-a	8900646	Screw 20 Torx SS	2 Pc's	
264	8076632-77	Holder	3 Pc's	
266	8079130-36	PLATERACK SHORT&THIN LEFT	1 Pc's	
269	8079131-36	PLATERACK SHORT&THIN RIGHT	1 Pc's	
272	8079123-36	PLATERACK SHORT LEFT D-GREY	1 Pc's	
273	8079124-36	PLATERACK SHORT RIGHT D-GREY	1 Pc's	
275	8070614	SEALING STRIPE TRIM STRIPE USA	2 Pc's	
276	8801330-77	HANDLE U-BASKET COMPL. ASKO	1 Pc's	
277	8801332-77	HANDLE LOWER BASKET COMPL.	1 Pc's	

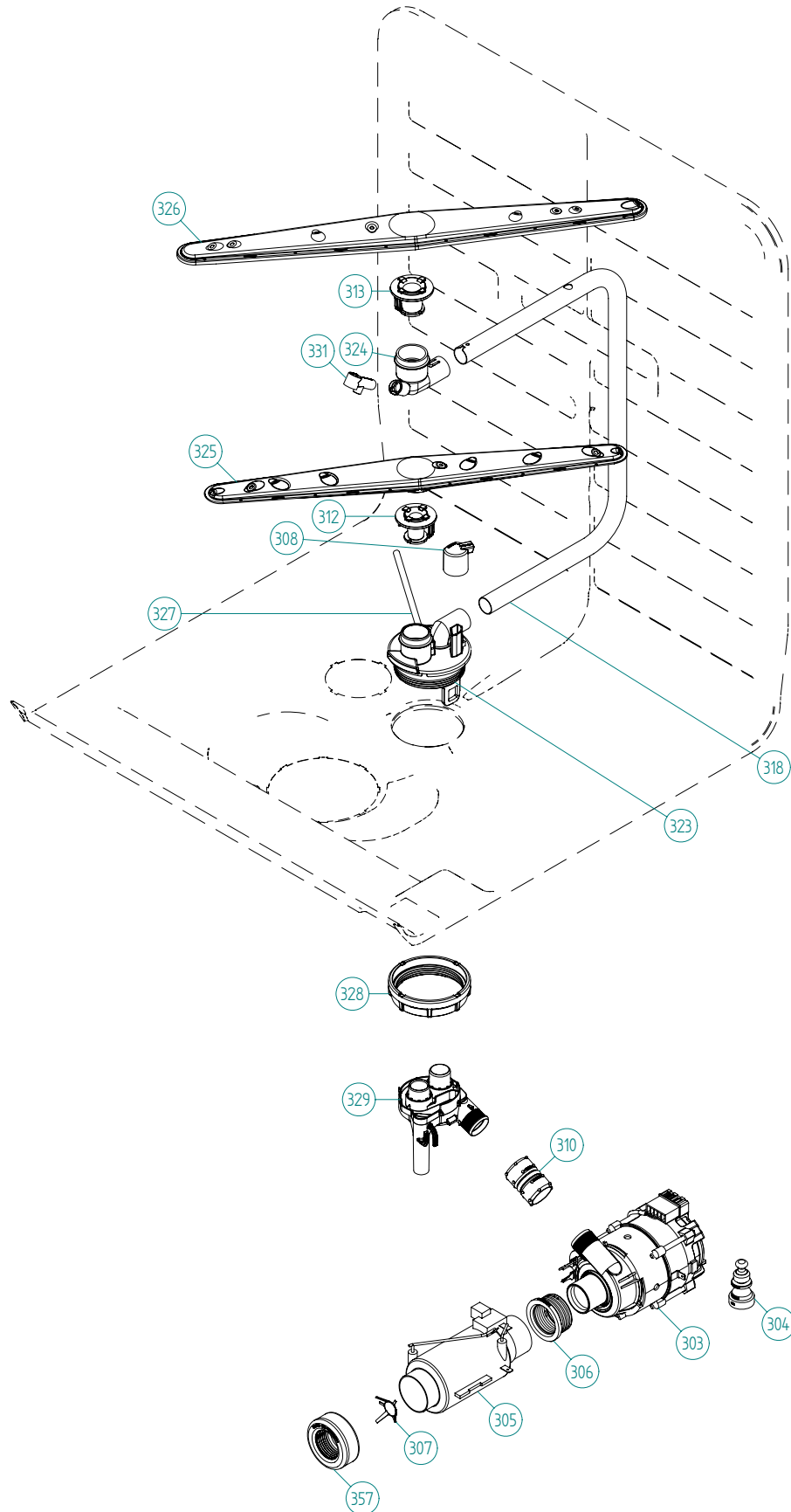

Wash System

ASKO, D5122 XL US - Sense Black (DW70.1)

Pos	Spare part No.	Description	Qty	Comment
301	8077998	-	1 Pc's	Not to be ordered
303	8078082	CIRC.PUMP 120V 60HZ	1 Pc's	
303-a	8083804	Capacitor 7,0UF 400V P2 CLASS	1 Pc's	
304	8079683	RUBBER DAMPER HI CIRC.PUMP UL4	1 Pc's	
305	8079505-1	HEATINGELEMENT 1200W 120V	1 Pc's	
305	8079505	HEATING ELEMENT 1200W DW70	1 Pc's	
306	8079531	SEALING HEATER DW70 UL4	1 Pc's	
307	8079575	INSERT FOR HEATER	1 Pc's	
308	8073385-77	Cup Drainage Gray	1 Pc's	
310	8072888	Hose Circ Pump	1 Pc's	
310-a	8056491	HOSE CLIP 30.1-708	2 Pc's	
312	8076901-77	Spray arm bearing	1 Pc's	
313	8076903-77	Repl by kit 8801268 (Pos 324)	1 Pc's	
318	8073387	Spray Pipe	1 Pc's	
323	8801270	KIT SPRAYARM BEAR. LOW NOZZLE	1 Pc's	
323-a	8901765	ORing det Comp 03/04 DW	1 Pc's	
324	8801268	KIT SPRAYARM BEAR. UPPER DW20	1 Pc's	
325	8072891	Spray Arm Lower Complete	1 Pc's	
326	8072894	Spray Arm Upper Complete	1 Pc's	
327	8073381	Tube Pot Rinse	1 Pc's	
327-a	8902085	Screw 20T for Plastic	2 Pc's	
328	8071607	Locking Spray Pipe Bearing	1 Pc's	
329	8078086	INTERMEDIATE	1 Pc's	
331	8072543-77	Spray Nozzle	1 Pc's	For part no 8073381 and 8072730-L-77
357	8083603	SEALING HEATER BOTTOM SUMP	1 Pc's	

- CD: COMBI DISPENSER
 - CP: CIRCULATION PUMP
 - DIV: WATER DIVERTER VALVE
 - DP: DRAIN PUMP
 - DR: DOOR
 - DS: DOOR SWITCH
 - F: FILTER
 - FM: FLOW METER
 - FN 1: FAN DOOR
 - FN 2: FAN BOTTOM
 - FS: FLOAT SWITCH
 - HE: HEATING ELEMENT
 - HE (PTC): HEATING ELEMENT PTC
 - HL: HALOGEN LAMP
 - HS: HUMIDITY SENSOR
 - IS: ILLUM. SWITCH
 - IV: INLET VALVE
 - I2C: I2C
 - MS: MAIN SWITCH
 - MV: MIX VALVE
 - PS: PRESSURE SENSOR
 - RAS: RINSE AID SENSOR
 - SL: STATUS LIGHT
 - SS: SALT SENSOR
 - SV: SALT VALVE
 - TH: THERMISTOR
 - TS: TURBIDITY SENSOR
 - UART: UART
 - VAX: VAX ACTUATOR
- WIRES IN ALL MACHINES
 - - - INTERNAL CONNECTION
 - · - WIRES IN SOME MACHINES

RESISTANCES AT ROOM TEMPERATURE (CA. 20°C/68°F)
VALUES WITH +/-10% ARE REGARDED AS NORMAL

COMPONENT	RESISTANCE
RADIO INTERFERENCE SUPPRESSION FILTER	1 MOHM
HEATING ELEMENT 1200W 120V	12 OHM
HEATING ELEMENT 1600W 230V	32 OHM
HEATING ELEMENT 2040W 230V	25 OHM
THERMISTOR	25 KOHM
COMBINED DISPENSER 120V	0.3 KOHM
COMBINED DISPENSER 230V	1,6 KOHM
CIRCULATION PUMP 120V 60HZ	32 OHM
CIRCULATION PUMP 230V 50HZ	110 OHM
CIRCULATION PUMP 220V 60HZ	56 OHM
DRAIN PUMP 120V 60HZ	25 OHM
DRAIN PUMP 230V 50HZ	150 OHM
DRAIN PUMP 230V 60HZ	85 OHM
SPRAY ARM DIVIDER 120V 60HZ	2.6 KOHM
SPRAY ARM DIVIDER 230V 50/60HZ	8,5 KOHM
INLET VALVE SINGLE INCL. 120V	0.95 KOHM
INLET VALVE SAFETY INCL. 120V	0.5 KOHM
INLET VALVE SINGLE INCL. 230V	3,9 KOHM
INLET VALVE SAFETY INCL. 230V	2 KOHM
SALT VALVE 120V	0,65 KOHM
MIX VALVE 120V	0,65 KOHM
SALT VALVE 230V	3 KOHM
MIX VALVE 230V	2,3 KOHM
HALOGEN LAMP 5W 12V	<10 KOHM
WAX MOTOR	1.1 KOHM
FAN MOTOR 120V	0.18 KOHM
FAN MOTOR 230V	0,85 KOHM

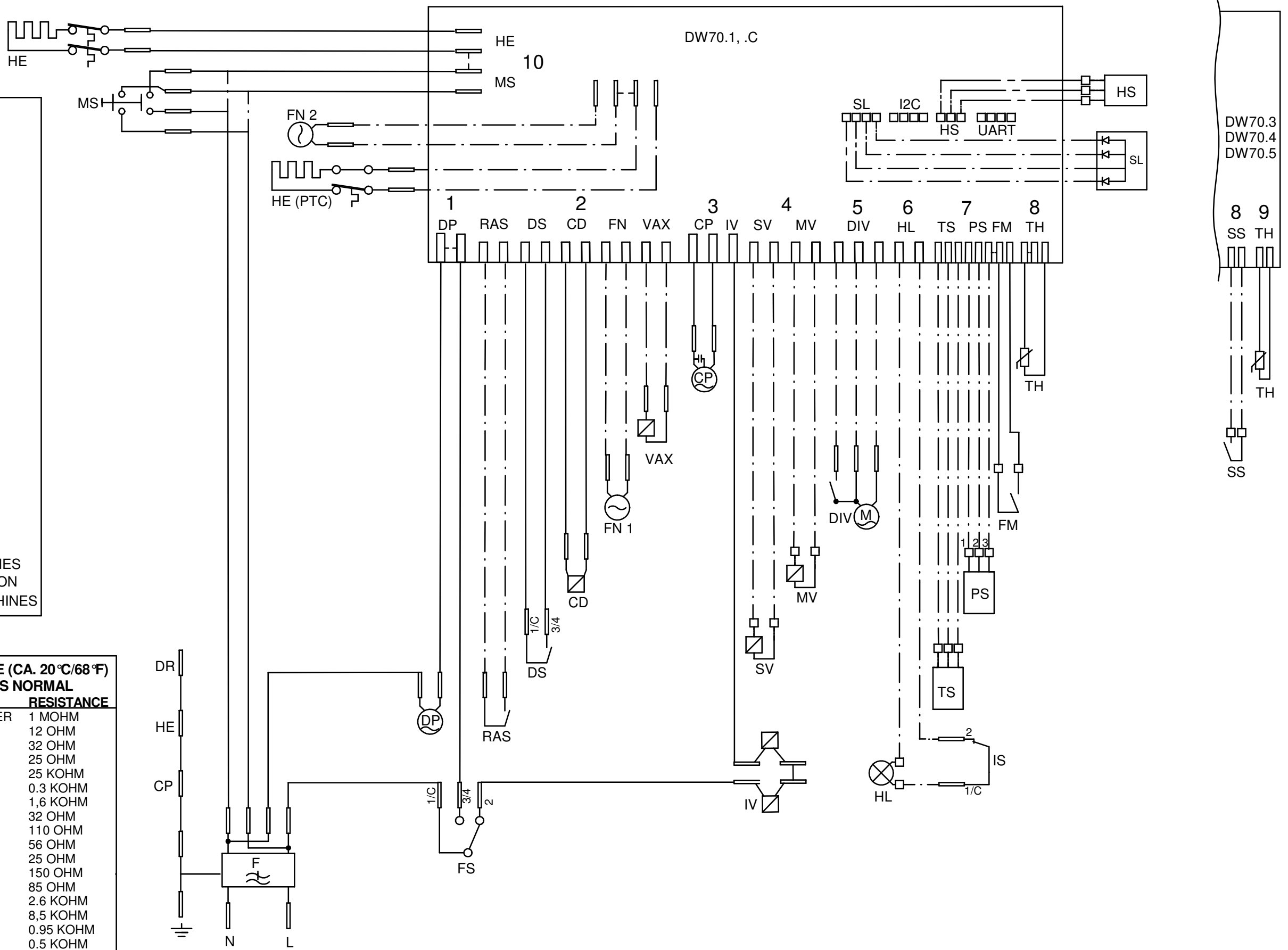

CIRCUIT DIAGRAM DW70.1, .3, .4, .5, .C
80 796 55 - 01

This document must not be copied without our written permission, and the contents thereof must not be imparted to a third party nor be used for any unauthorized purpose. Contravention will be prosecuted. Asko Appliances AB

Displays

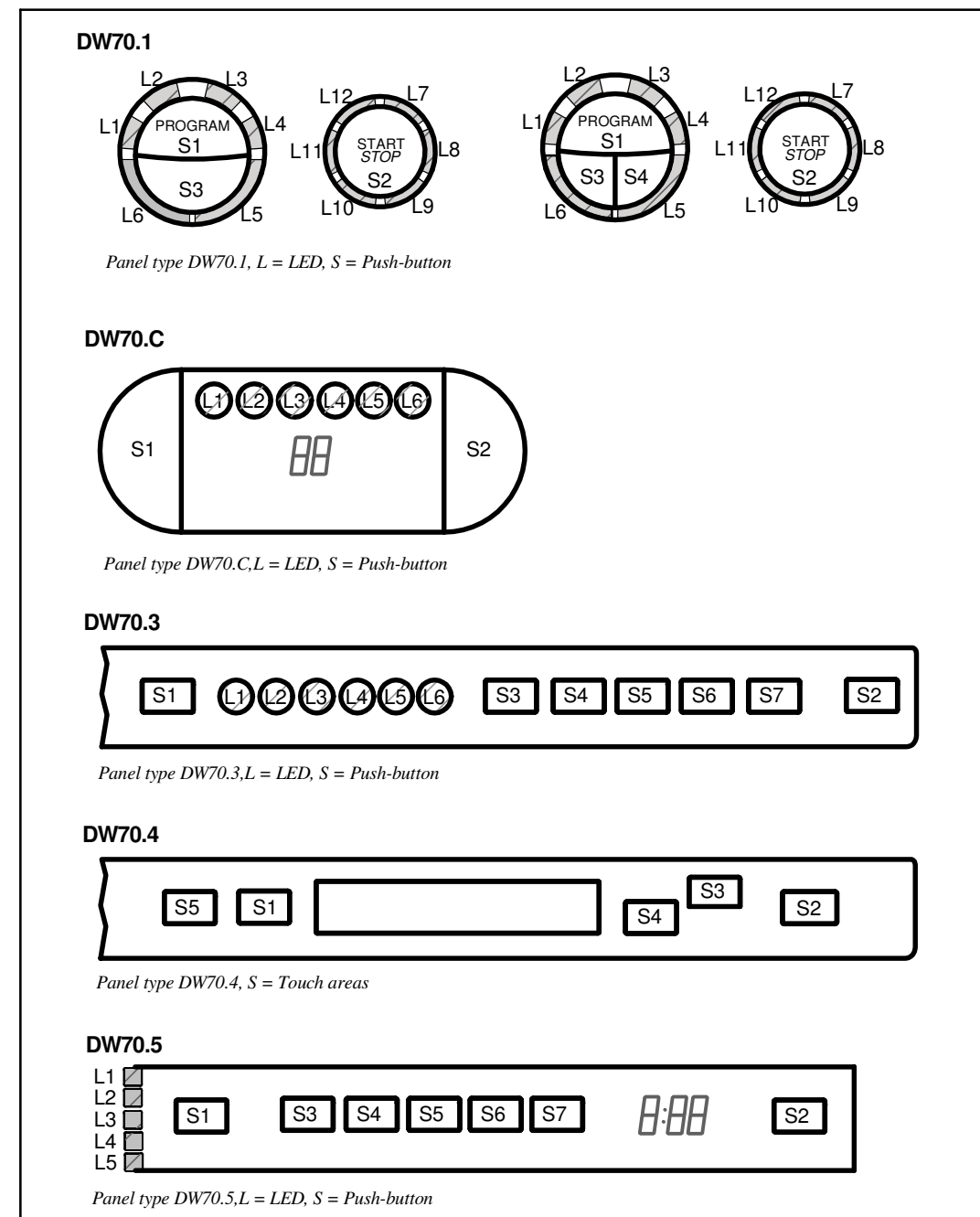

TOTAL RESET

TURN OFF MAIN SWITCH
 WAIT FOR AT LEAST 5 SECS
 HOLD PROGRAM BUTTON (S1), FOR DW70.4 HOLD PROGRAM BUTTON (S1)
 AND NAVIGATION BUTTON (S4).
 TURN ON MAIN SWITCH
 RELEASE PROGRAM BUTTON (S1), FOR DW70.4 RELEASE PROGRAM BUTTON (S1)
 AND NAVIGATION BUTTON (S4).

SERVICE MENU

TURN OFF MAIN SWITCH
 WAIT FOR AT LEAST 5 SECS
 HOLD PROGRAM AND START BUTTONS (S1 & S2)
 TURN ON MAIN SWITCH
 RELEASE PROGRAM AND START BUTTONS (S1 & S2)

VARIANT SETTING (NOT DW70.4)

HOLD PROGRAM AND START BUTTONS (S1 & S2)
 TURN ON MAIN SWITCH
 RELEASE PROGRAM AND START BUTTONS
 PRESS START (S2) 3 TIMES WITHIN 5 SECS
 SELECT VARIANT BY START BUTTON (S1) AND
 CONFIRM BY START BUTTON (S2)

COMPONENT TEST:

First enter Service menu.

DW70.1, DW70.3, DW70.5 and DW70.C

Component test:

Press the Program button (S1) and index through the following components:

1. Inlet valve and mix valve (only machines with water softener)
2. Inlet valve
3. Salt valve (only machines with water softener)
4. Detergent and surfactant dispenser
5. Circulation pump
6. Heating element and circulation pump (Max 75°C)
7. Fans
8. Drain pump

DW70.4

First enter service menu.

Go to service menu step 2, Diagnostics, by pressing S4

Press (S3) to activate the following components:

1. Valve (Inlet valve and mix valve (only machines with water softener), display flowsensor value)
2. Valve (Inlet valve, display flowsensor value)
3. Salt (Salt valve, only machines with water softener)
4. Disp (Detergent and surfactant dispenser)
5. Circ (Circulation pump, display shows turbidity in Volts)
6. Heat (Heating element and circulation pump (Max 75°C))
7. Fans (display shows humidity sensor value)
8. Drain (Drain pump, display shows pressure sensor reading; 0.5-3.5 VDC)

CIRCUIT DIAGRAM DW70.1, .3, .4, .5, .C

80 796 55 - 01

This document must not be copied without our written permission, and the contents thereof must not be imparted to a third party nor be used for any unauthorized purpose. Contravention will be prosecuted.
 Askö Appliances AB