

This Owner's Manual is provided and hosted by [Appliance Factory Parts](#).

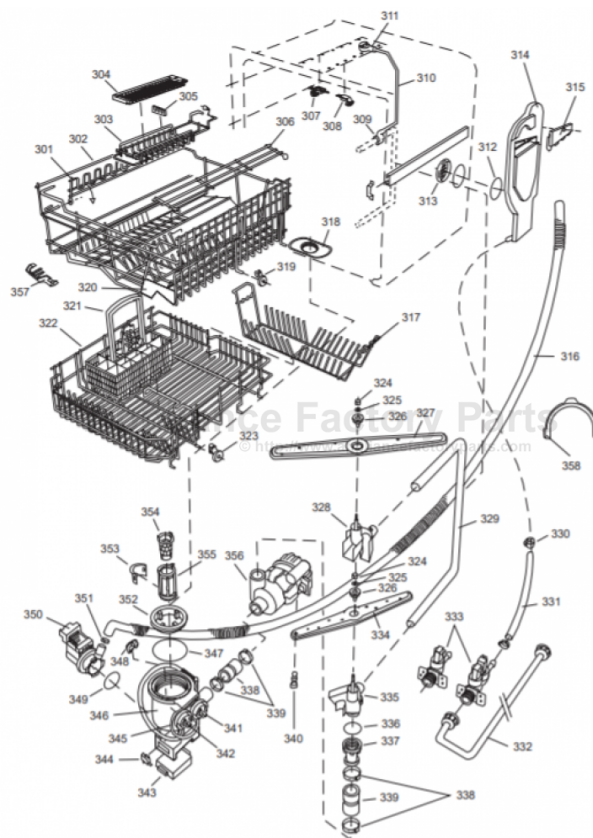

ASKO 1485SS Owner's Manual

[Shop genuine replacement parts for ASKO 1485SS](#)



[Find Your ASKO Dishwasher Parts - Select From 210 Models](#)

----- Manual continues below -----

Fault Tracing

A high-speed photograph of a single water droplet falling into a pool of water. The droplet is captured mid-fall, just above the surface, with a small splash of water below it. The impact has created a series of concentric, circular ripples that spread outwards from the center. The water is a deep blue color, and the lighting is soft, highlighting the texture of the ripples and the clarity of the droplet.

1475, 1485, 1776 & 1796FI

Dishwashers

ASKO

Fault Tracing

- Use this program to test components
- To start fault tracing program
 - Press rinse and hold button 5 times within 15 seconds

Program Buttons

- **Press Normal Wash button**
 - Tests detergent dispenser
- **Press Normal Wash button again**
 - Tests rinse agent dispenser
- **Press Pots and Pans button**
 - Tests the inlet valve

Program Buttons

- **Press Quick Wash button**
 - Tests the heater
- **Press Rinse and Hold button**
 - Tests the circulation pump
- **Press Heated Dry button**
 - Tests the drain pump and fan motor

To Exit

- When finished with the test
 - Hold down any program button and the program will be cancelled

Inlet Time Adjustments

A high-speed photograph of a water droplet falling into a pool of water. The droplet is captured mid-fall, just above the surface, with a small splash of water below it. The impact has created a series of concentric ripples that spread outwards from the center. The background is a solid, deep blue color.

1475, 1485, 1776 & 1796FI

Dishwashers

ASKO

To Enter Program

- Press the **Quick Wash** button five times within 15 sec.

Program Buttons

- **Pots and Pans button**
 - Press once to reset to normal 60 sec. fill
- **Normal Wash button**
 - Press once to increase inlet time by 15 sec.
- **Quick Wash button**
 - Press once to increase inlet time by 30 sec.

Program Buttons

➤ Rinse and Hold button

- Press once to increase inlet time by 60 sec.

➤ Heated Dry button

- Press once to increase inlet time by 120 sec.

Drain Time Adjustments

A high-speed photograph of a single water droplet falling into a pool of water. The droplet is captured mid-fall, just above the surface, with a small splash of water below it. The impact has created a series of concentric, circular ripples that spread outwards from the center. The background is a solid, deep blue color.

1475, 1485, 1776 & 1796FI

Dishwashers

ASKO

To Enter Program

- Press the **Pots and Pans** button 5 times within 15 sec.

Program Buttons

➤ Normal Wash button

- Press once to reset to normal drain time

➤ Quick Wash button

- Press once to increase drain time by 10 sec.

Program Buttons

- **Rinse and Hold** button
 - Press once to increase drain time by 20 sec.
- **Heated Dry** button
 - Press once to increase drain time by 60 sec.
- **Pots and Pans** button
 - Press once to decrease drain time by 5 sec.