

Spare Parts Catalogue

Dishwashers \ 3000XL Series
Type: DW20.3
Model: D3232 XL US SSHDNL

Prod. No: 107323241
February 24th 2007

AM Appliances Group

P.O. Box 851805 • Richardson • TX 75085-1805
789 N. Grove Road • Suite 103 • Richardson • TX 75081

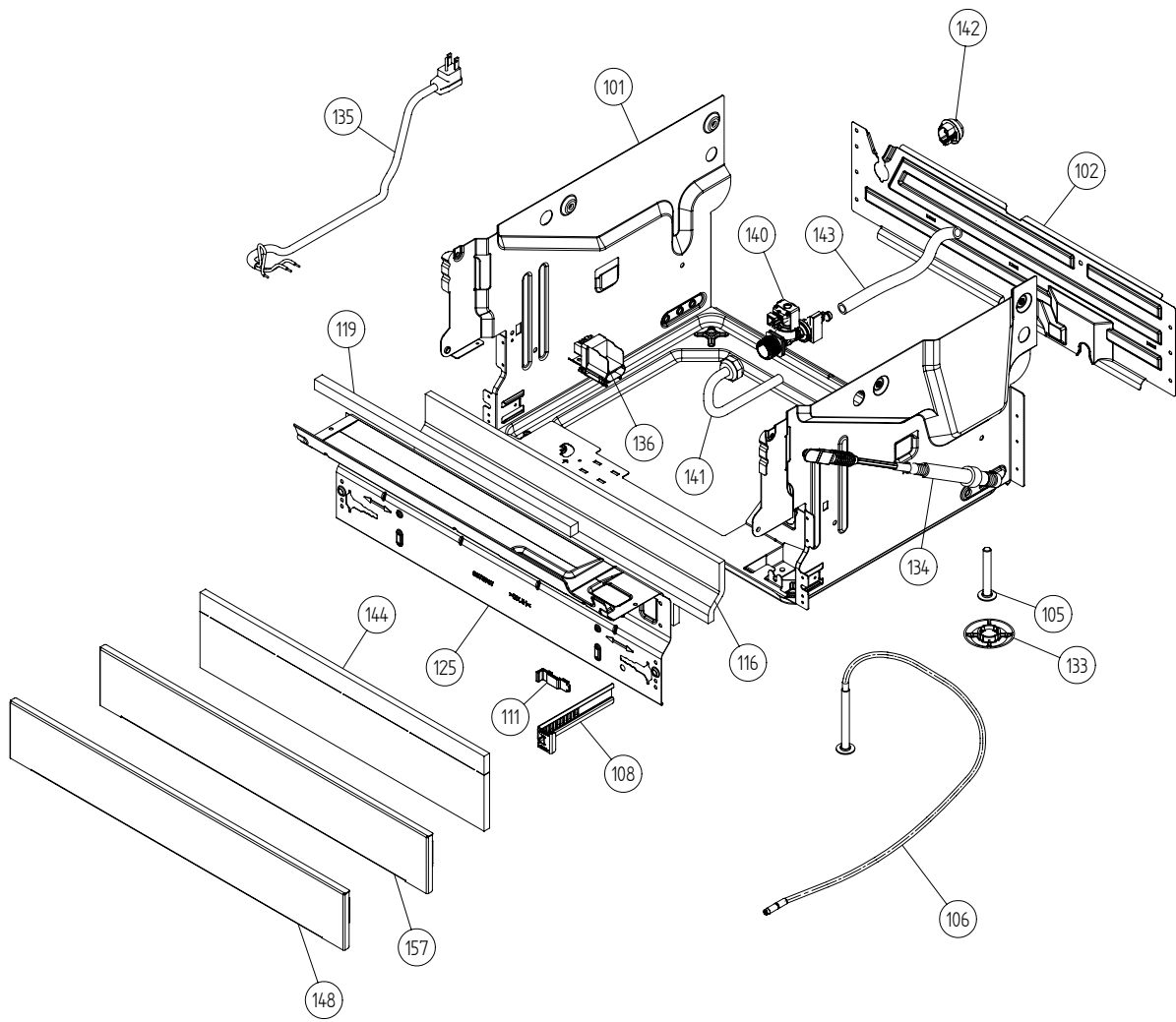

Base and related parts

ASKO, D3232 XL US - SSHDNL (DW20.3)

Pos	Spare part No.	Description	Qty	Comment
101	8074450	Bottom Outer DW20	1 Pc's	
101-a	8901104	Screw 20 Torx Machine	2 Pc's	
101-b	8901110	Screw w/ORing DW 05/06 25T	4 Pc's	
102	8073880	REAR PANEL	1 Pc's	
102-a	8902357	Screw	5 Pc's	
105	8074228	Foot	2 Pc's	
106	8073647	FOOT ADJUSTABLE FROM FRONT CPL	1 Pc's	
108	8073480	Toe Kick bracket Right & Left	2 Pc's	
111	8073481-49	Spring Kicking Plate L Gray	2 Pc's	
116	8058353	Sound Absorb Guard	1 Pc's	
119	8074260	SOUND ABSORBTION PROFILE	1 Pc's	
125	8076822	GUARD PLATE	1 Pc's	
133	8051957	Slide foot 02 DW	3 Pc's	
134	8071323-77	DW Extra Heavy Duty Door Spr	1 Pc's	
134	8076163-77	Door spring	1 Pc's	
135	8073774	Cord Set	1 Pc's	
135	8079046	CORD SET AMERICA	1 Pc's	
136	8079045	TERMINAL BLOCK D3000 W/ RFI	1 Pc's	
136-a	8902131	Screw	1 Pc's	
140	8073825	Inl Valve Single 120V Sens	1 Pc's	
140-a	8052189	Hose Clamp Squeeze	1 Pc's	
141	8073879	Fill hose quick connect	1 Pc's	
142	8006948	Grommet	1 Pc's	
143	8074230	Rubber Hose	1 Pc's	
143-a	8052189	Hose Clamp Squeeze	2 Pc's	
148	8073506-81	kick plate metallic	1 Pc's	
148	8073506	KICK-PLATE USA 86CM	1 Pc's	
162	8079832	CABLE HOLDER SRC-8-01	1 Pc's	

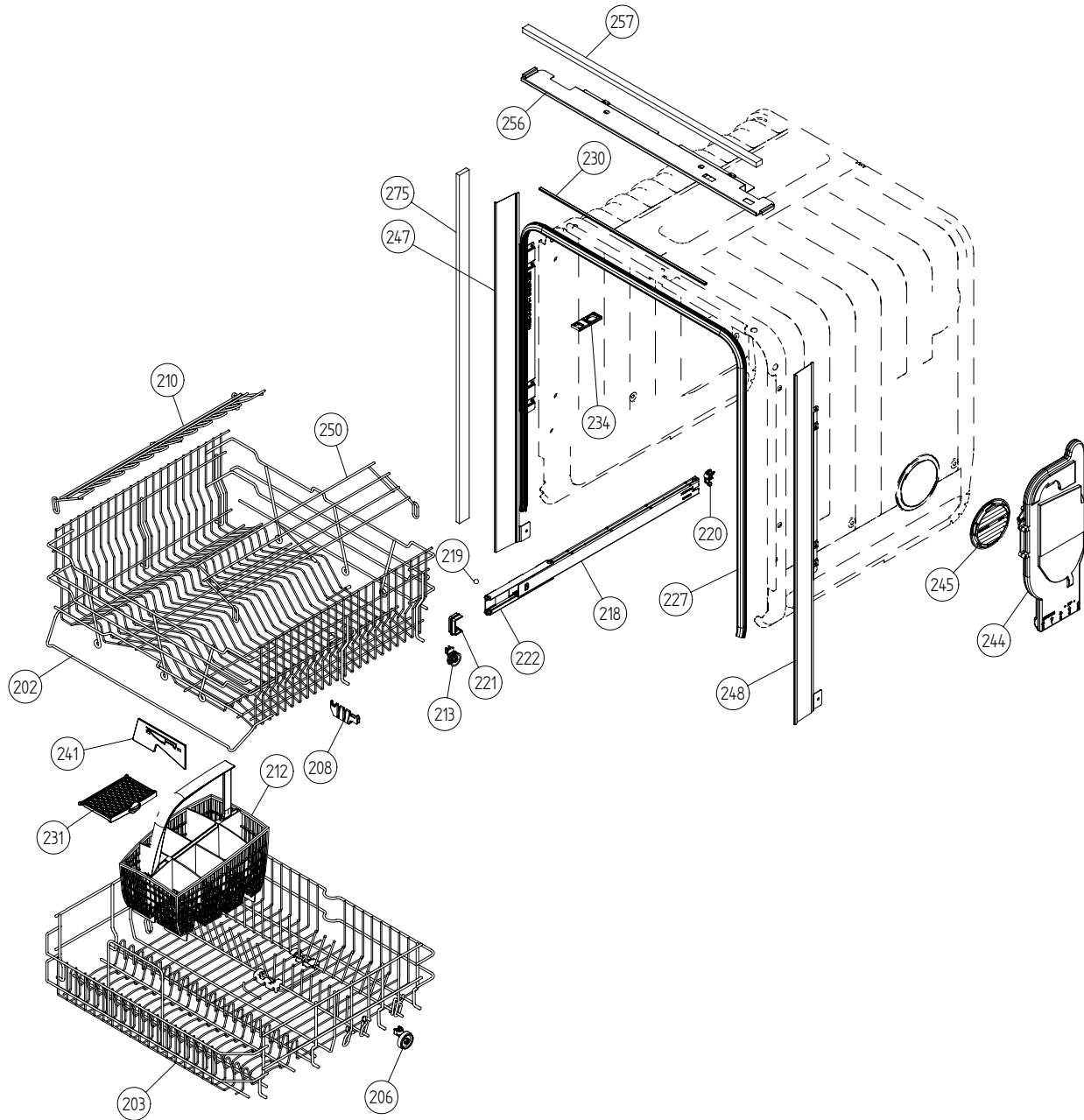

Baskets and related parts

ASKO, D3232 XL US - SSHDNL (DW20.3)

Pos	Spare part No.	Description	Qty	Comment
201	8057056	-	1 Pc's	Not a spare part
202	8801236-36	Upper Basket Gray	1 Pc's	
203	8078644-36	LOWER BASKET EXKL. CPL NET DFP	1 Pc's	
206	8078641-77	Rack Wheels Lower 05/06 DW	8 Pc's	
208	8071214-77	Knife Holder 05/06 DW	2 Pc's	
210	8071337-36	Cup Shelf Wine Glass 05/06 DW	1 Pc's	
212	8801239-77	Cutlery Basket incl Door	1 Pc's	
213	8058498-77	Wheel Upper Basket 05/06 DW	4 Pc's	
218	8057052	Guide Rail 05 06 DW	2 Pc's	
219	8057977	Bearing Upper Rail 05/06 DW	8 Pc's	
220	8057978-77	Rail Stop Back Grey 05/06 DW	2 Pc's	
221	8057979-77	Rack Stop Grey 05/06 DW	2 Pc's	
222	8058638-77	Ball Holder Upper Rail DW	2 Pc's	
225	8057978-77	Rail Stop Back Grey 05/06 DW	2 Pc's	
227	8057489-E	Door strip 3000xl	1 Pc's	
230	8071257	Edge Guard	1 Pc's	
231	8072986-77	Door Cutlery Basket	1 Pc's	
234	8070649	Lock Hitch Int	1 Pc's	
234-a	8070648	Lock Washer Int	1 Pc's	Part of 8070469
234-b	8901104	Screw 20 Torx Machine	1 Pc's	
241	8057506-77	Knife Stop	1 Pc's	
244	8057514	Sub To 8801234	1 Pc's	
244-a	8052189	Hose Clamp Squeeze	1 Pc's	
245	8057536-77	Lockring Airbreak Gray	1 Pc's	
247	8074342-E-95	Trim strip left 3000xl	1 Pc's	
247-a	8900646	Screw 20 Torx SS	2 Pc's	
248	8074343-E-95	Trim strip right 3000xl	1 Pc's	
248-a	8900646	Screw 20 Torx SS	2 Pc's	
250	8073507-36	cup shelf 3000xl	1 Pc's	
256	8075663-95	trim rail 3000xl	1 Pc's	
257	8075664	sealing stripe 3000xl	1 Pc's	
275	8070614	SEALING STRIPE TRIM STRIPE USA	2 Pc's	

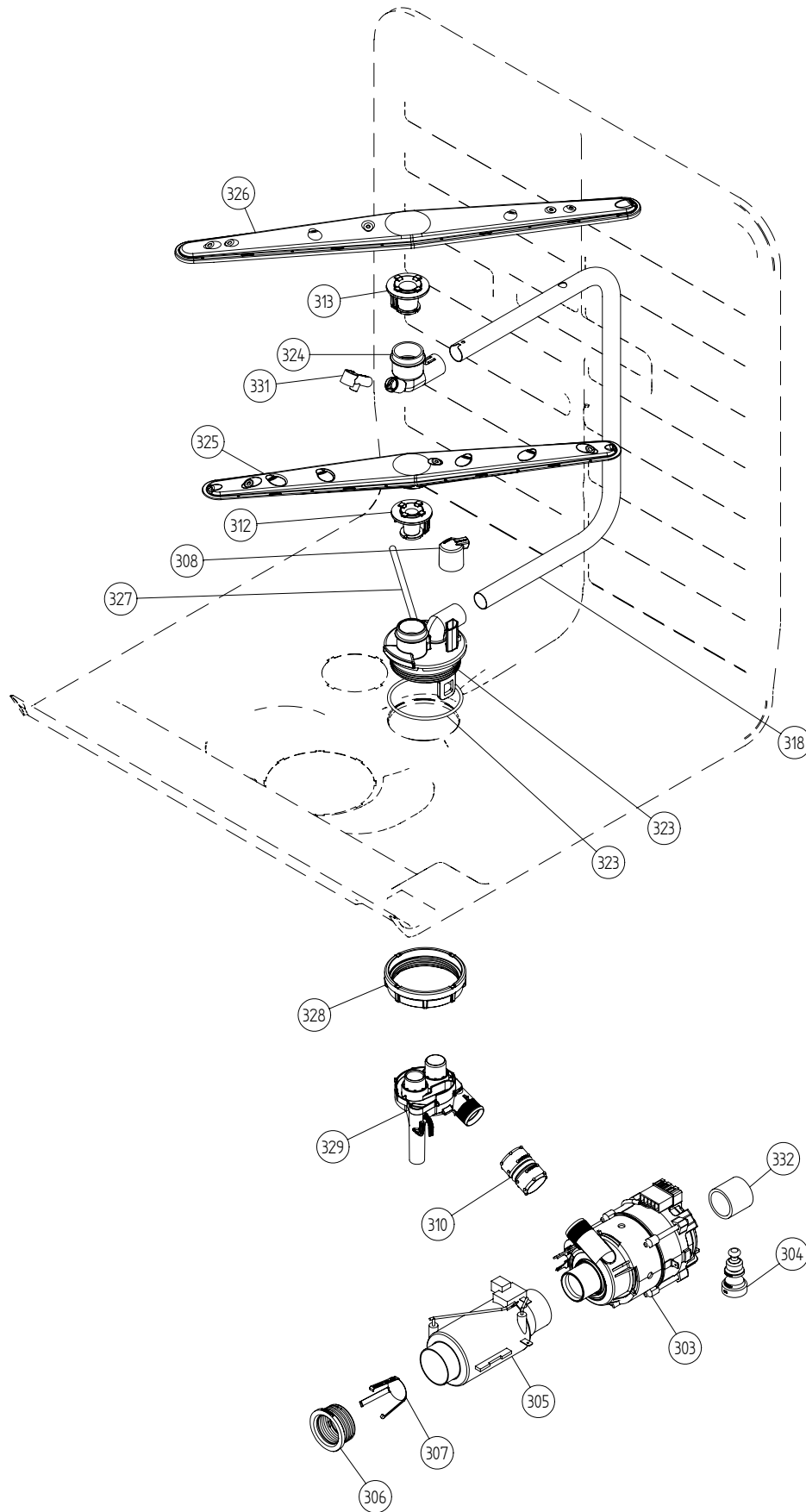

Wash System

ASKO, D3232 XL US - SSHDNL (DW20.3)

Pos	Spare part No.	Description	Qty	Comment
301	8073502	-	1 Pc's	Not to be ordered
303	8073813	Circ Pump 120V 60HZ	1 Pc's	
303-a	8075380	capacitor D3000	1 Pc's	
304	8075130	Rubber Damper Circ Pump	1 Pc's	
305	8073785	Heating Element 1200W 120V	1 Pc's	
306	8073702	Element Transmutation	2 Pc's	
307	8075070	INSERT FOR HEATER	1 Pc's	
308	8073385-77	Cup Drainage Gray	1 Pc's	
310	8072888	Hose Circ Pump	1 Pc's	
310-a	8056491	Hose Clamp Squeeze	2 Pc's	
312	8072728-77	Spray Arm Bearing L Gray	1 Pc's	
312	8076901-77	Spray arm bearing	1 Pc's	
313	8072731-77	Subs to 8801268	1 Pc's	
313	8076903-77	Subs to 8801268	1 Pc's	
318	8073387	Spray Pipe	1 Pc's	
323	8801270	Spray arm bearing kit	1 Pc's	
323-a	8901765	ORing det Comp 03/04 DW	1 Pc's	
324	8801268	Spray arm bearing kit	1 Pc's	
325	8072891	Spray Arm Lower Complete	1 Pc's	
326	8072894	Spray Arm Upper Complete	1 Pc's	
327	8073381	Tube Pot Rinse	1 Pc's	
327-a	8902085	Screw 20T for Plastic	2 Pc's	
328	8071607	Lockring Spray Pipe Bearing	1 Pc's	
329	8075936	subs to 8073823	1 Pc's	
329-a	8079895	O-RING 20,0 X 4,0 NBR70	2 Pc's	
331	8072543-77	Spray Nozzle	1 Pc's	For part no 8073381 and 8072730-L-77
332	8075420	Hose	1 Pc's	
332-a	8052189	Hose Clamp Squeeze	2 Pc's	

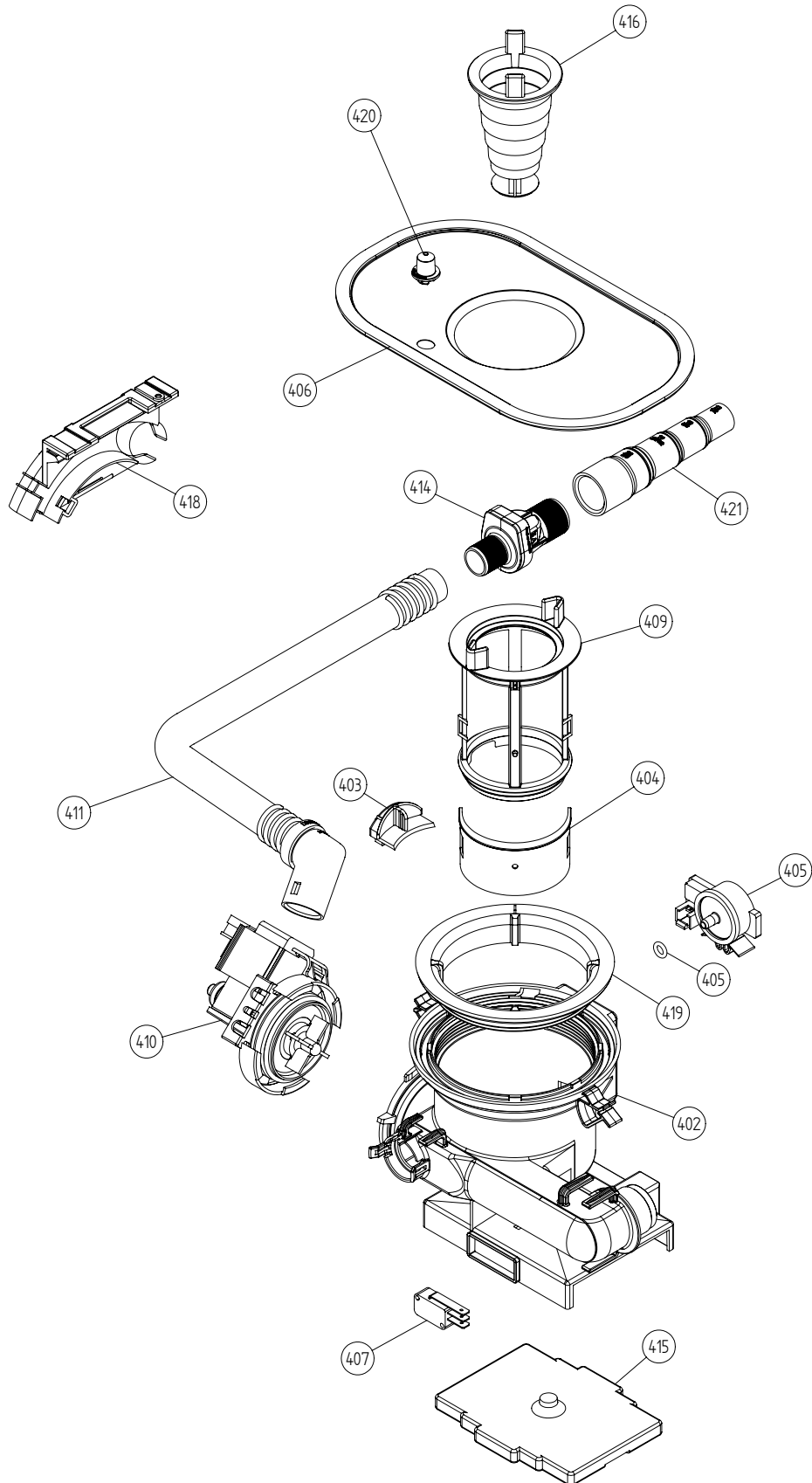

Bottom well and related parts

ASKO, D3232 XL US - SSHDNL (DW20.3)

Pos	Spare part No.	Description	Qty	Comment
402	8073690-77	Bottom Well w/o Sensor	1 Pc's	
402	8073691-77	Bottom Well Pressure Sensor	1 Pc's	
402-a	8073002	ORing	1 Pc's	
403	8057487-79	Sump Plug DW 05/06 Cleanout	1 Pc's	
404	8058454	Cover Str Basket 05/06 DW	1 Pc's	
405	8073839	Pressure Sensor	1 Pc's	
405-a	8074040	ORing	1 Pc's	
406	8074364	STRAINER DW20	1 Pc's	
407	8073835	MICROSWITCH FLOAT	1 Pc's	
409	8073396-77	INSERT STRAINER BASKET	1 Pc's	
410	8073818	Drain Pump D3000 DW	1 Pc's	
410-a	8002584	ORing Drain Pump 05/06 DW	1 Pc's	
411	8074030	Outlet Hose D3000 DW	1 Pc's	
411-a	8052239	Hose Clamp Squeeze	1 Pc's	
411-b	8052430	Cable Strip	1 Pc's	
414	8801248	Check Valve Kit	1 Pc's	
414-a	8052239	Hose Clamp Squeeze	1 Pc's	
414-b	8053642	Hose Clip	1 Pc's	
415	8075110	FLOAT	1 Pc's	
416	8057972-77	Strainer Basket Grey 05/06 DW	1 Pc's	
418	8072528-77	Holder Outlet Hose	1 Pc's	
418-a	8053642	Hose Clip	1 Pc's	
418-b	8052239	Hose Clamp Squeeze	1 Pc's	
418-c	33700450	Cable Strip	1 Pc's	
418-d	8902072	Screw	1 Pc's	
419	8072848	Lockring Bottom Well	1 Pc's	
420	8074760-77	Ventilator	1 Pc's	
421	8075321	End Cuff	1 Pc's	

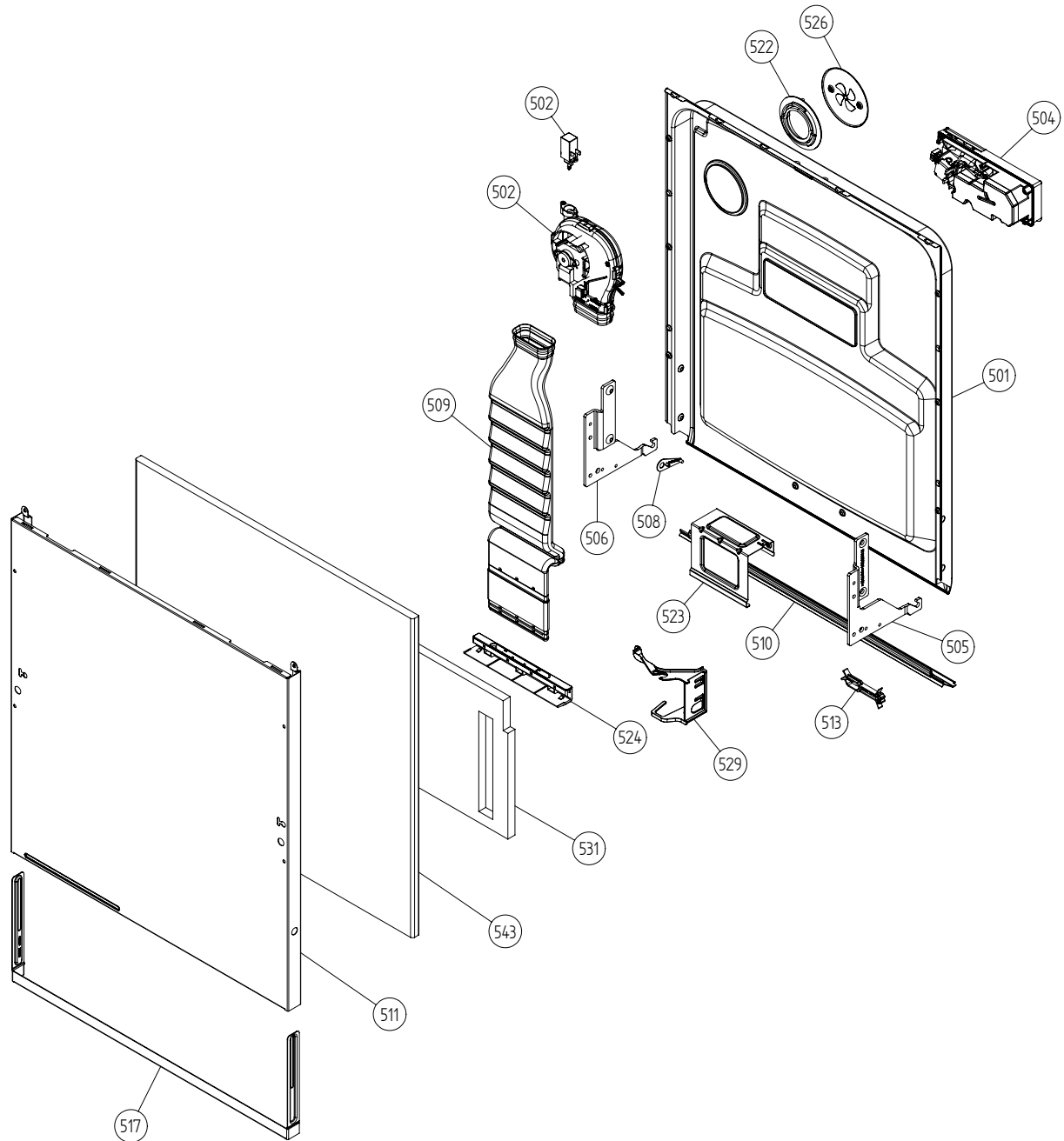

Inner door, panel and related parts

ASKO, D3232 XL US - SSHDNL (DW20.3)

Pos	Spare part No.	Description	Qty	Comment
501	8801254	Inner Door 3251XL	1 Pc's	
501-a	8900646	Screw 20 Torx SS	6 Pc's	
501-b	8902121	Screw	4 Pc's	
502	8073851	Fan Complete 120V	1 Pc's	
502-a	8058501	ORing Turbo Fan Dry 05/06 DW	1 Pc's	
502-b	8052778	WAX MOTOR DW 05/06	1 Pc's	
504	8073803	Combidisp Reed Reay 120V	1 Pc's	
504-a	8071916	Subs to 8071918	1 Pc's	
504-b	8071917	CAP RINSE AGENT	1 Pc's	
504-c	8071918	Detergent Lid Complete	1 Pc's	
504-d	8072288	Sealing Strip Combbidisp	1 Pc's	
504-f	8902087	Screw Plastic Housing 20 Torx	6 Pc's	
505	8057524	Hinge Right DW 05/06	1 Pc's	
505-a	8057530	Screw hinge 05	1 Pc's	
505-b	33500262	Nut Term Block	1 Pc's	
506	8057525	Hinge left DW 05/06	1 Pc's	
506-a	8057530	Screw hinge 05	1 Pc's	
506-b	33500262	Nut Term Block	1 Pc's	
507	8057530	Screw hinge 05	2 Pc's	
507-a	33500262	Nut Term Block	2 Pc's	
508	8057948	Slide washer hinge bearing 05	2 Pc's	
509	8057963-P	Air Channel Adj 1895 FI	1 Pc's	
510	8060254	Lower SealInner Door 05/06 DW	1 Pc's	
511	8074800-PT	DOOR OUTER LONG INT. ADJUST.	1 Pc's	
511	8074800-PT-81	Outer door long 3000XL	1 Pc's	
511-a	8900646	Screw 20 Torx SS	6 Pc's	
513	8074015	CABLE BRACKET DOOR	1 Pc's	
517	8074012-81	Adj Frame Air Channel	1 Pc's	
517-a	8902133	Screw	2 Pc's	
522	8057964	Locking ring turbo fan 05	1 Pc's	
522-a	8902085	Screw 20T for Plastic	2 Pc's	
523	8057983	Brace	1 Pc's	
523-a	8900646	Screw 20 Torx SS	2 Pc's	
523-b	8902357	Screw	2 Pc's	
524	8072732-33	Nozzle Air Duct	1 Pc's	
526	8058484	SS Coverplate Turbo Fan DW	1 Pc's	
526-a	8902085	Screw 20T for Plastic	2 Pc's	
529	8074278	Bracket for harness	1 Pc's	
531	8074258	Sound Absorbion Outer Door	1 Pc's	
543	8072927	SOUND INSULATION FRONT DOOR	1 Pc's	

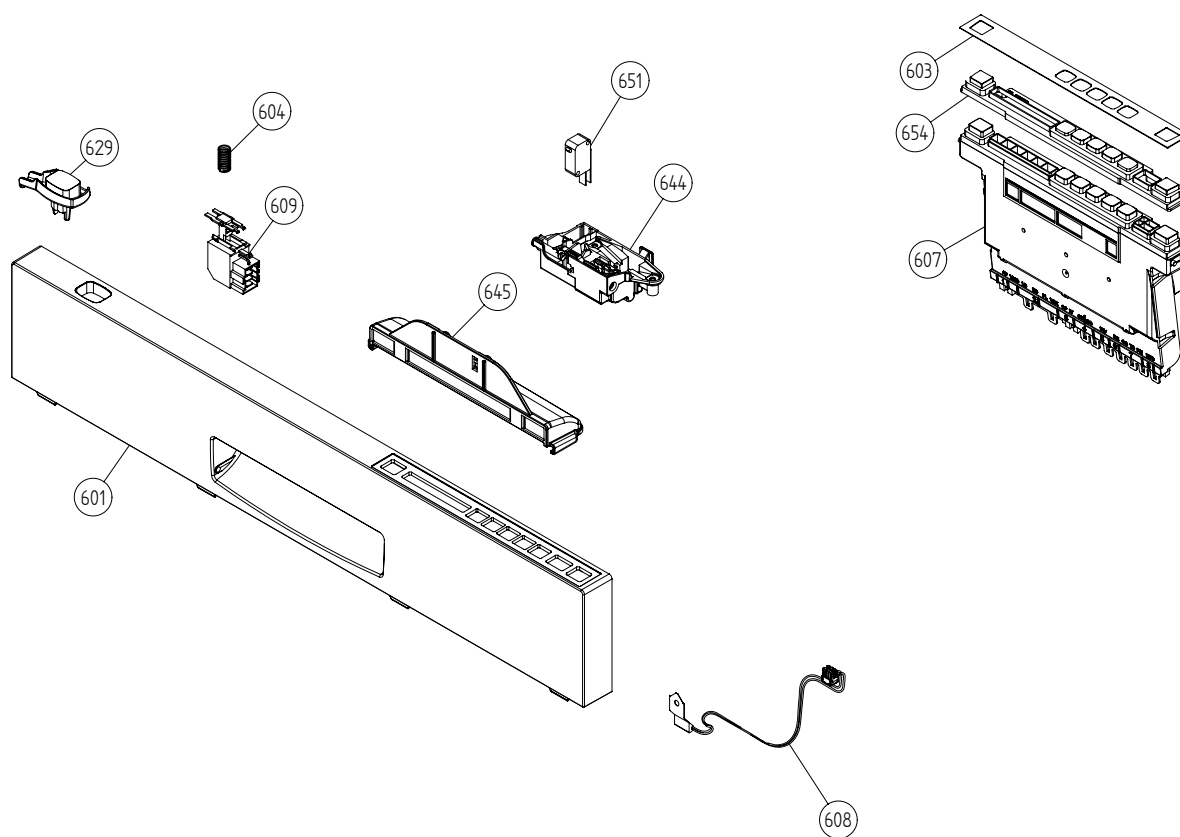

Control panel and related parts

ASKO, D3232 XL US - SSHDNL (DW20.3)

Pos	Spare part No.	Description	Qty	Comment
601	8078424-81-UL	Control panel 3232	1 Pc's	
602	8078192	Program info label US/AU	1 Pc's	
602	8078207	Program info label USFR	1 Pc's	
602	8078313	Program info label US ES	1 Pc's	
603	8075839	Decor plate	1 Pc's	
603	8078865	DECOR PLATE ASKO 343T/FI GRAP.	1 Pc's	
604	8074277	SPRING MAIN SWITCH	1 Pc's	
607	8801282	control unit DW203 US	1 Pc's	
608	8073788	Thermistor	1 Pc's	
608-a	8076839	thermistor spacer	1 Pc's	
609	8073782	MAIN PUSH SWITCH	1 Pc's	
614	8075736	cablE set	1 Pc's	
616	8075735	CABLE SET FLOW & PRESSURE	1 Pc's	
617	8075737	CABLE SET FLOW SENSOR	1 Pc's	
618	8075738	cablE set power	1 Pc's	
620	8075730	cablE set fan	1 Pc's	
622	8075731	CABLE SET DRAIN	1 Pc's	
629	8075078-81	Push Button Main Switch Graphi	1 Pc's	
644	8073670	Lock Complete Integrated	1 Pc's	
645	8073666	HANDLE INTEGRATED LOCK	1 Pc's	
645-a	8072439	Bolt Tension Strap W600s	2 Pc's	
651	8073836	MICROSWITCH DOOR	1 Pc's	
654	8075722-81	Pushbuttons DW343T/FI	1 Pc's	
690	8078390	Info label 3232 EN	1 Pc's	
690	8078391	Info label 3432 FR	1 Pc's	
690	8078392	INSTRUCTIONS D3232-343F USA ES	1 Pc's	

This document must not be copied without our written permission, and the contents thereof must not be imparted to a third party without the written permission of Askjo Cylinda AB.

S:\UDW2011_Tryckunderlag\Kopplingsschema\8073809 Circuit diagram DW20.4_c.dft , mail , 2002-06-18 08:34:08

CD: COMBI DISPENSER
 CP: CIRCULATION PUMP
 DIV: WATER DIVERTER VALVE
 DP: DRAIN PUMP
 DR: DOOR
 DS: DOOR SWITCH
 F: FILTER
 FM: FLOW METER
 FN: FAN
 FS: FLOAT SWITCH
 HE: HEATING ELEMENT
 HL: HALOGEN LAMP
 HS: HUMIDITY SENSOR
 IS: ILLUM. SWITCH
 IV: INLET VALVE
 MS: MAIN SWITCH
 PS: PRESSURE SENSOR
 RAS: RINSE AID SENSOR
 SS: SALT SENSOR
 SV: SALT VALVE
 TH: THERMISTOR
 TS: TURBIDITY SENSOR
 VAX: VAX ACTUATOR
 NET: INTERFACE TO HOME NET COMMUNICATION UNIT

— WIRES IN ALL MACHINES
 - - - INTERNAL CONNECTION
 - · - WIRES IN SOME MACHINES

RESISTANCES AT ROOM TEMPERATURE (CA. 20°C/68°F)
VALUES WITH +/-10% ARE REGARDED AS NORMAL

COMPONENT	RESISTANCE
RADIO INTERFERENCE SUPPRESSION FILTER	1 MOHM
HEATING ELEMENT 1400W 120V	12 OHM
HEATING ELEMENT 1800W 230V	30 OHM
THERMISTOR	25 KOHM
COMBINED DISPENSER 120V	0.3 KOHM
COMBINED DISPENSER 230V	1.3 OHM
CIRCULATION PUMP 120V 60HZ	22 OHM
CIRCULATION PUMP 230V 50HZ	90 OHM
CIRCULATION PUMP 220V 60HZ	56 OHM
DRAIN PUMP 120V 60HZ	25 OHM
DRAIN PUMP 230V 50HZ	150 OHM
DRAIN PUMP 230V 60HZ	85 OHM
SPRAY ARM DIVIDER 120V 60HZ	2.6 KOHM
SPRAY ARM DIVIDER 230V 50/60HZ	8.5 KOHM
INLET VALVE SINGLE INCL. FLOW SENSOR 120V	0.95 KOHM
INLET VALVE SAFETY INCL. FLOW SENSOR 120V	0.5 KOHM
INLET VALVE WATER SOFTNER INCL. FLOW SENSOR 120V	0.95 KOHM
INLET VALVE SINGLE INCL. FLOW SENSOR 230V	3.8 KOHM
INLET VALVE SAFETY INCL. FLOW SENSOR 230V	2 KOHM
INLET VALVE WATER SOFTNER INCL. FLOW SENSOR 230V	3.8 KOHM
HALOGEN LAMP 5W 12V	<10 KOHM
WAX MOTOR	1.1 KOHM
FAN MOTOR 120V	0.18 KOHM
FAN MOTOR 230V	0.75 KOHM

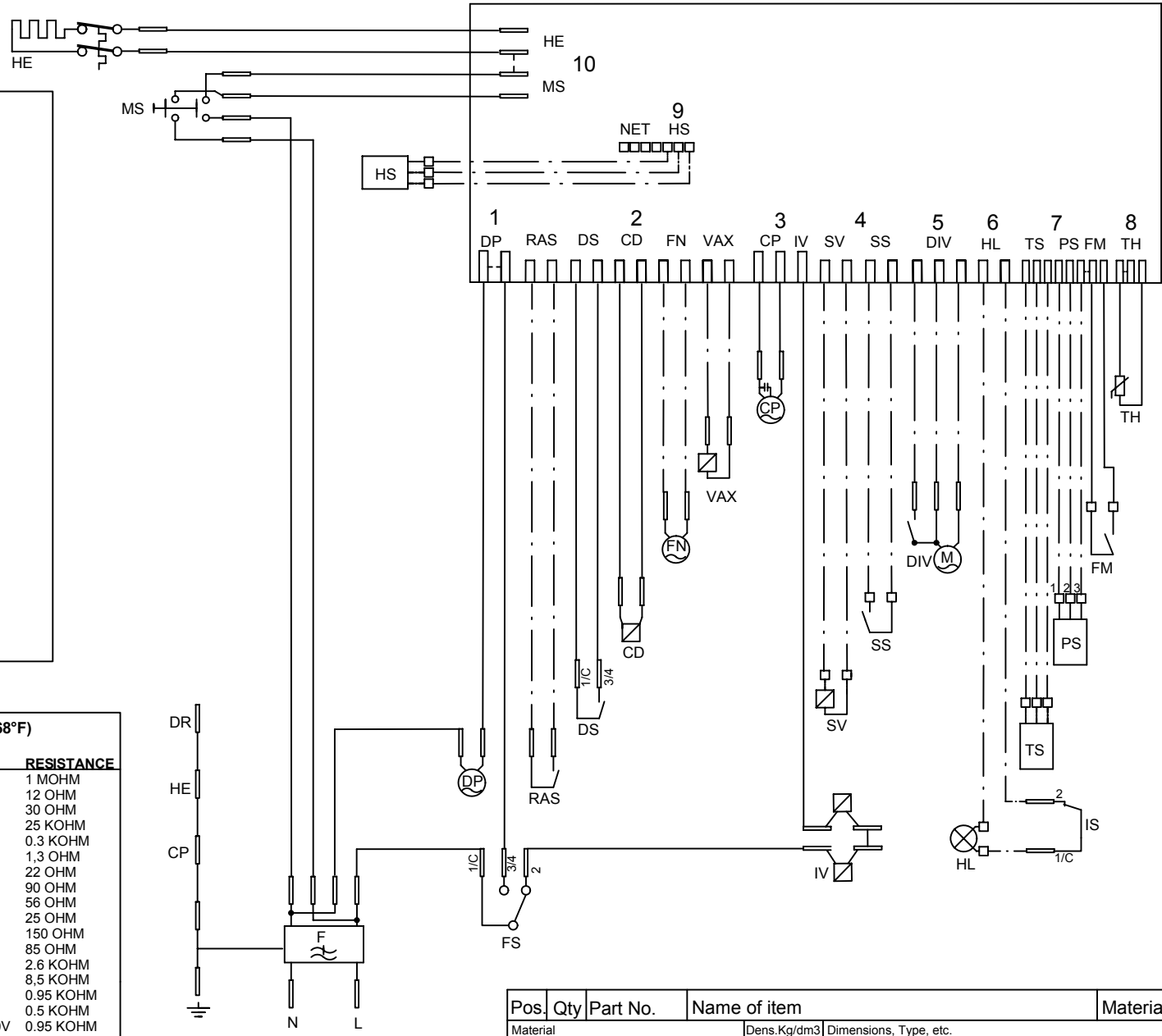

Pos.	Qty	Part No.	Name of item	Material
Material		Dens.Kg/dm3	Dimensions, Type, etc.	
Scale	1:1	Gen.tolerance	Description(ENG) CIRCUIT DIAGRAM DW20.1, .2, .3, .4, .C	
Designed by	ML	Gen.tol.Angle	Description(SE) KOPPLINGSSCHEMA DW20.1, .2, .3, .4, .C	
Released by	UD	Iss by Dept	Year	Week
			00	41
			80 738 09	Rev Ind 00
				Replace
				Project

Rev ind	Revision	Appd	Year	Week

Displays

DW20.1

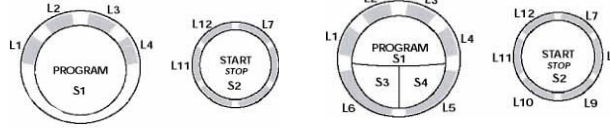

Panel type DW20.1, L = LED, S = Push-button

DW20.2



Panel type DW20.2, L - LED, S - Push-button, D - Display

DW20.3



Panel type DW20.3, L - LED, S - Push-button

DW20.4



Panel type DW20.4, L - LED, S - Push-button

TOTAL RESET

- TURN OFF MAIN SWITCH
- WAIT FOR AT LEAST 5 SECS
- HOLD PROGRAM BUTTON (S1)
- TURN ON MAIN SWITCH
- RELEASE PROGRAM BUTTON (S1)

SERVICE MENU

- TURN OFF MAIN SWITCH
- WAIT FOR AT LEAST 5 SECS
- *HOLD PROGRAM AND START BUTTONS (S1 & S2)
- TURN ON MAIN SWITCH
- RELEASE PROGRAM AND START BUTTONS (S1 & S2)
- *FOR DW20.4 HOLD TEMPERATURE/SET AND DRYING/MENU (S3 & S4)

VARIANT SETTING

- *ACTIVATE THE SERVICE MENU
- PRESS START (S2) 3 TIMES WITHIN 5 SECS
- *FOR DW20.4
- HOLD PROGRAM AND START BUTTONS (S1 & S2)
- TURN ON MAIN SWITCH
- RELEASE PROGRAM AND START BUTTONS
- PRESS START (S2) 3 TIMES WITHIN 5 SECS

COMPONENT TEST:

First enter Service menu.

DW20.1

No component test available.

DW20.2 and DW20.3

Component test:

Press the Programme button (S1) and index through the following components:

1. Inlet valve
2. Salt valve (only machines with water softener)
3. Detergent and surfactant dispenser
4. Circulation pump
5. Heating element and circulation pump (Max 75°C)
6. Fan
7. Drain pump

DW20.4

First enter service menu.

Press Drying/Menu (S4) to access component diagnostics.

Press Temperature/Set (S3) to activate the following components:

1. Inlet valve (display shows water intake volume)
2. Salt valve (only machines with water softener)
3. Detergent and surfactant dispenser
4. Circulation pump (display shows turbidity in Volts)
5. Heating element and circulation pump (Max 75°C)
6. Fan (display shows humidity sensor value)
7. Drain pump (display shows pressure sensor reading; 0.5-3.5 VDC)

Pos.	Qty	Part No.	Name of item	Material
Material		Dens.Kg/dm3	Dimensions, Type, etc.	
Scale	1:1	Gen.tolerance	Description(ENG) CIRCUIT DIAGRAM DW20.1, .2, .3, .4, .C	
Designed by	ML	Gen.tol.Angle	Description(SE) KOPPLINGSSCHEMA DW20.1, .2, .3, .4, .C	
Released by	UD	Iss by Dept	Year	Week
			00	41
ASKO CYLINDA			80 738 09	00
			Rev Ind	Replace
				Project

Rev ind	Revision	Appd	Year	Week
---------	----------	------	------	------