



Spare Parts Catalogue

Dishwashers \ 3000 Std Tank Series
Type: DW20.3
Model: D3252 US Titanium FI

Prod. No: 107325231
May 23rd 2005

AM Appliances Group

P.O. Box 851805 • Richardson • TX 75085-1805
789 N. Grove Road • Suite 103 • Richardson • TX 75081

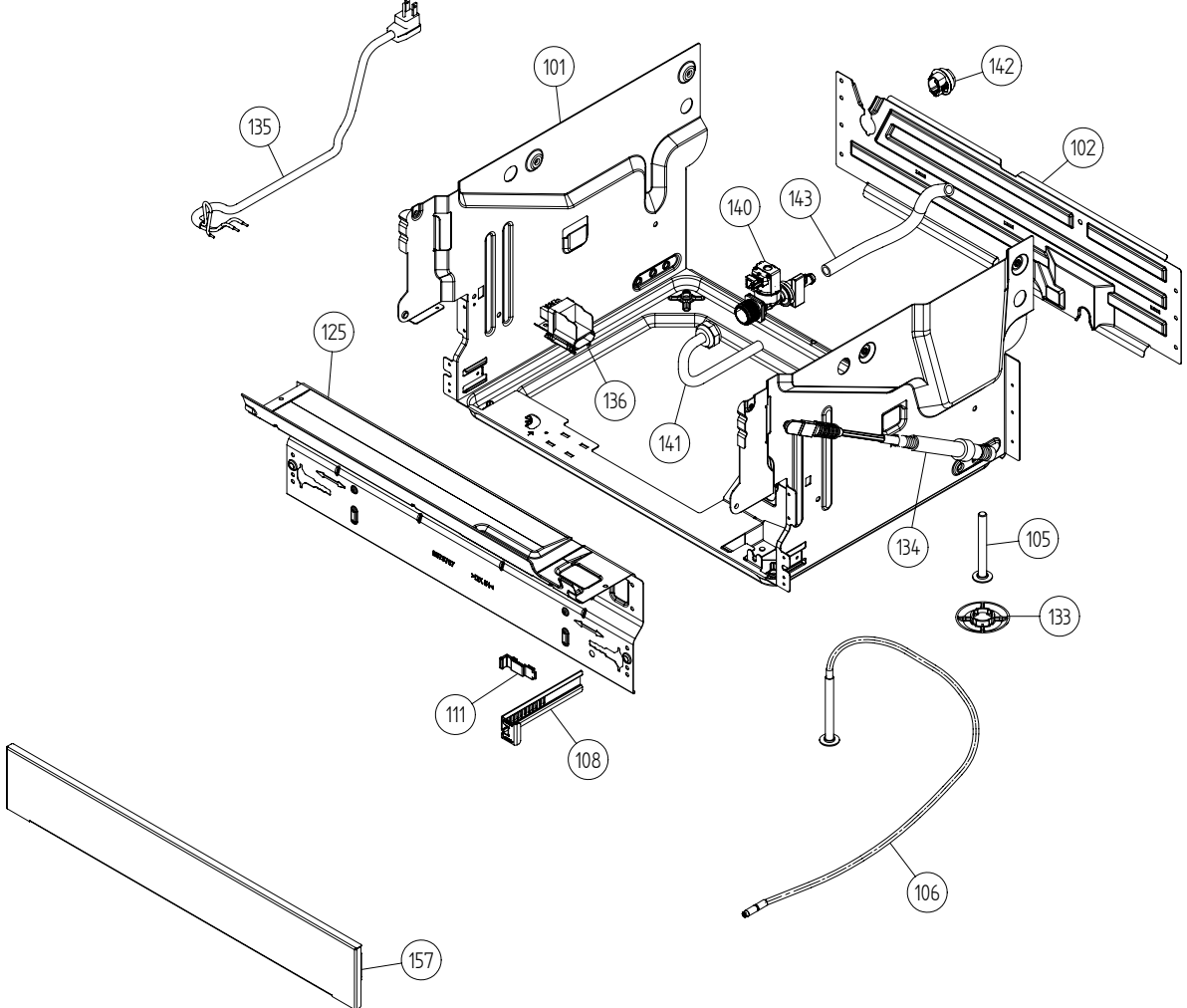

Base and related parts

ASKO, D3252 US - Titanium FI (DW20.3)

Pos	Spare part No.	Description	Qty	Comment
101	8074450	Bottom Outer DW20	1 Pcs	
101-a	8901104	Screw 20 Torx Machine	2 Pcs	
101-b	8901110	Screw w/ORing DW 05/06 25T	4 Pcs	
102	8073880	REAR PANEL	1 Pcs	
102-a	8902357	Screw	5 Pcs	
105	8074877	Foot	2 Pcs	
106	8073647	FOOT ADJUSTABLE FROM FRONT CPL	1 Pcs	
108	8073480	Toe Kick bracket Right & Left	2 Pcs	
111	8073481-49	Spring Kicking Plate L. Gray	2 Pcs	
125	8076822	GUARD PLATE	1 Pcs	
133	8051957	Slide foot 02 DW	3 Pcs	
134	8071323-77	DW Extra Heavy Duty Door Spr.	2 Pcs	
135	8073774	Cord Set	1 Pcs	
136	8073781	TERMINAL BLOCK D3000 W/ RFI	1 Pcs	
136-a	8902131	Screw	1 Pcs	
140	8073825	Inl. Valve Single 120V Sens.	1 Pcs	
140-a	8052189	Hose Clamp Squeeze	1 Pcs	
141	8073879	Fill hose quick connect	1 Pcs	
142	8006948	Grommet	1 Pcs	
143	8074230	Rubber Hose	1 Pcs	
143-a	8052189	Hose Clamp Squeeze	2 Pcs	
157	8073566-81	Toe Kick Mettalic	1 Pcs	

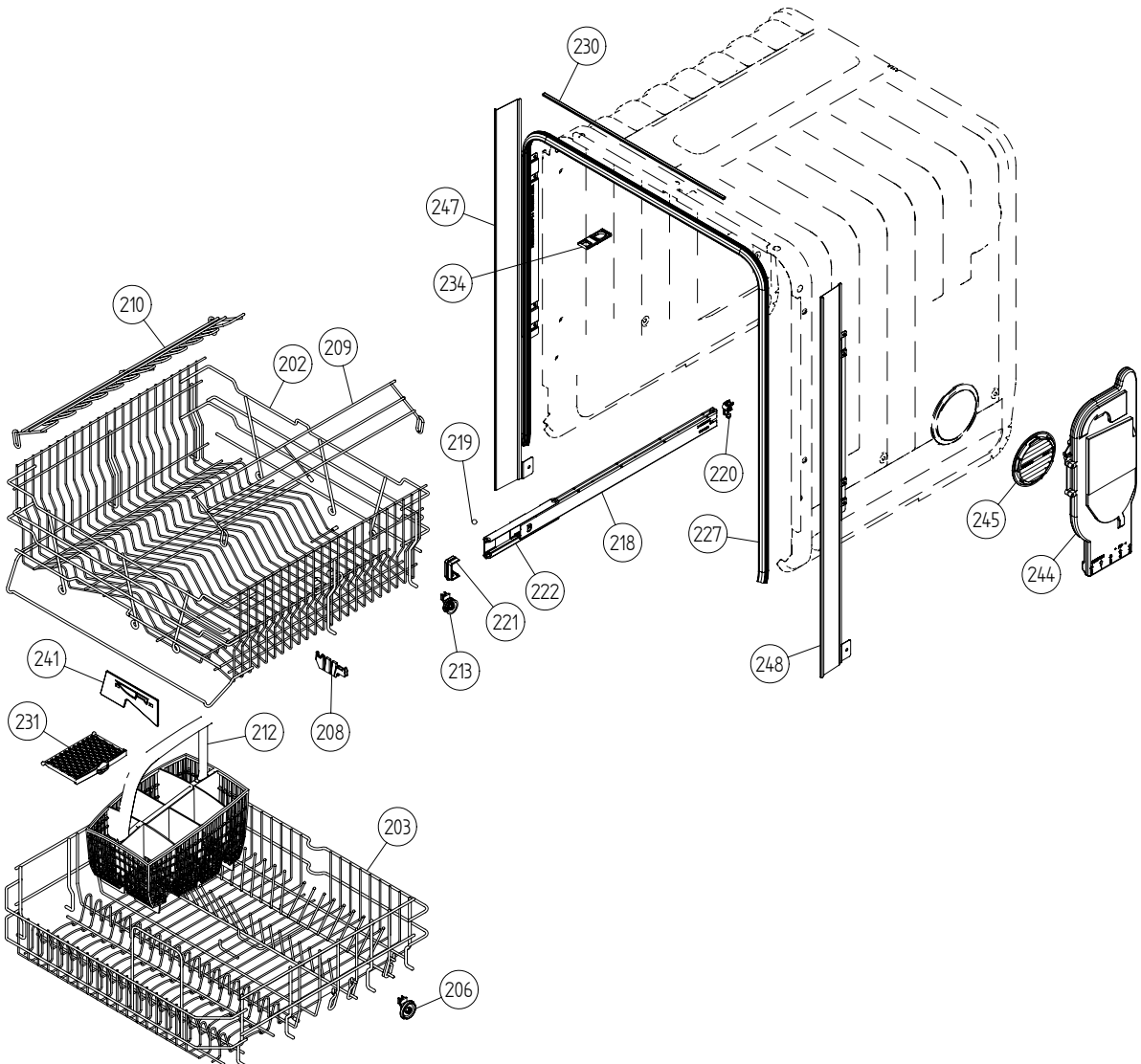

Baskets and related parts

ASKO, D3252 US - Titanium FI (DW20.3)

Pos	Spare part No.	Description	Qty	Comment
201	8057056	-	1 Pcs	Not a spare part
202	8801236-36	Upper Basket Gray	1 Pcs	
203	8801237-36	Lower Basket Gray	1 Pcs	
203-a	8801274-36	KIT DIVIDE PIN ROW STD D. GREY	1 Pcs	
203-b	8076632-77	HOLDER DFP	2 Pcs	
206	8009516-77	Rack Wheels Lower 05/06 DW	8 Pcs	
208	8071214-77	Knife Holder 05/06 DW	2 Pcs	
209	8071336-36	Cup Shelf 05/06 DW	1 Pcs	
210	8071337-36	Cup Shelf Wine Glass 05/06 DW	1 Pcs	
212	8801239-77	Cutlery Basket incl. Door	1 Pcs	
213	8058498-77	Wheel Upper Basket 05/06 DW	4 Pcs	
218	8057052	Guide Rail 05 06 DW	2 Pcs	
219	8057977	Bearing Upper Rail 05/06 DW	8 Pcs	
220	8057978-77	Rail Stop Back Grey 05/06 DW	2 Pcs	
221	8057979-77	Rack Stop Grey 05/06 DW	2 Pcs	
222	8058638-77	Ball Holder Upper Rail DW	2 Pcs	
225	8057978-77	Rail Stop Back Grey 05/06 DW	2 Pcs	
227	8057489	Tub Seal 05/06 DW	1 Pcs	
230	8071257	Edge Guard	1 Pcs	
231	8072986-77	Door Cutlery Basket	1 Pcs	
234	8070649	Lock Hitch Int.	1 Pcs	
234-a	8070648	Lock Washer Int.	1 Pcs	Part of 8070469
234-b	8901104	Screw 20 Torx Machine	1 Pcs	
241	8057506-77	Knife Stop	1 Pcs	
244	8057514	Sub To 8801234	1 Pcs	
244-a	8052189	Hose Clamp Squeeze	1 Pcs	
245	8057536-77	Lockring Airbreak Gray	1 Pcs	
247	8074342-81	TRIM STRIP LEFT USA METAL GREY	1 Pcs	
247-a	8900646	Screw 20 Torx SS	2 Pcs	
248	8074343-81	TRIM STRIP RIGHT USA MET. GREY	1 Pcs	
248-a	8900646	Screw 20 Torx SS	2 Pcs	

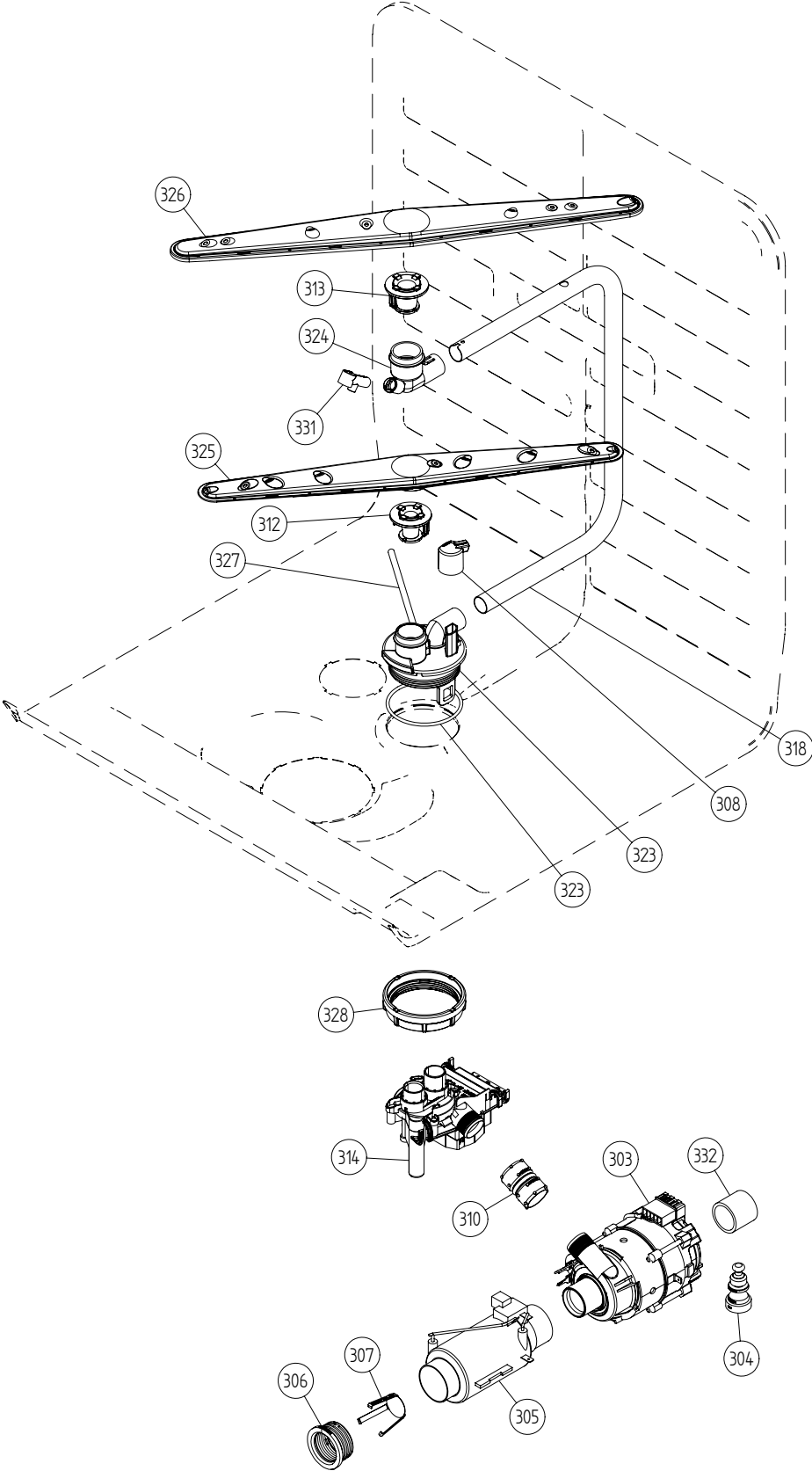

Wash system

ASKO, D3252 US - Titanium FI (DW20.3)

Pos	Spare part No.	Description	Qty	Comment
301	8072108	-	1 Pcs	Not to be ordered
303	8073813	Circ. Pump 120V 60HZ	1 Pcs	
303-a	8075380	capacitor D3000	1 Pcs	
304	8075130	Rubber Damper Circ. Pump	1 Pcs	
305	8073785	Heating Element 1200W 120V	1 Pcs	
306	8073702	Element Transmutation	2 Pcs	
307	8075070	INSERT FOR HEATER	1 Pcs	
308	8073385-77	Cup Drainage Gray	1 Pcs	
310	8072888	Hose Circ. Pump	1 Pcs	
310-a	8056491	Hose Clamp Squeeze	2 Pcs	
312	8076901-77	SPRAY ARM BEARING L. GREY UL4	1 Pcs	
312	8072728-77	Spray Arm Bearing L. Gray	1 Pcs	
313	8076903-77	SPRAYARM BEARING UPPER UL4	1 Pcs	
313	8801268	KIT SPRAYARM BEAR. UPPER DW20	1 Pcs	
314	8073822	Water Div. Valve 120V 60HZ	1 Pcs	
314-a	8073003	Oring	2 Pcs	
318	8073387	Spray Pipe	1 Pcs	
323	8801270	KIT SPRAYARM BEAR. LOW NOZZLE	1 Pcs	
323	8076900-L-77	SPRAYTOWER L. SPRAY NOZZLE UL4	1 Pcs	
323-a	8901765	ORing det. Comp. 03/04 DW	1 Pcs	
324	8801268	KIT SPRAYARM BEAR. UPPER DW20	1 Pcs	
324	8076902-L-77	SPRAYTOWER U. SPRAY NOZZLE UL4	1 Pcs	
325	8072891	Spray Arm Lower Complete	1 Pcs	
326	8072894	Spray Arm Upper Complete	1 Pcs	
327	8073381	Tube Pot Rinse	1 Pcs	
327-a	8902085	Screw 20T for Plastic	2 Pcs	
328	8071607	Lockring Spray Pipe Bearing	1 Pcs	
331	8072543-77	Spray Nozzle	1 Pcs	For part no 8073381 and 8072730-L-77
332	8075420	Hose	1 Pcs	
332-a	8052189	Hose Clamp Squeeze	2 Pcs	

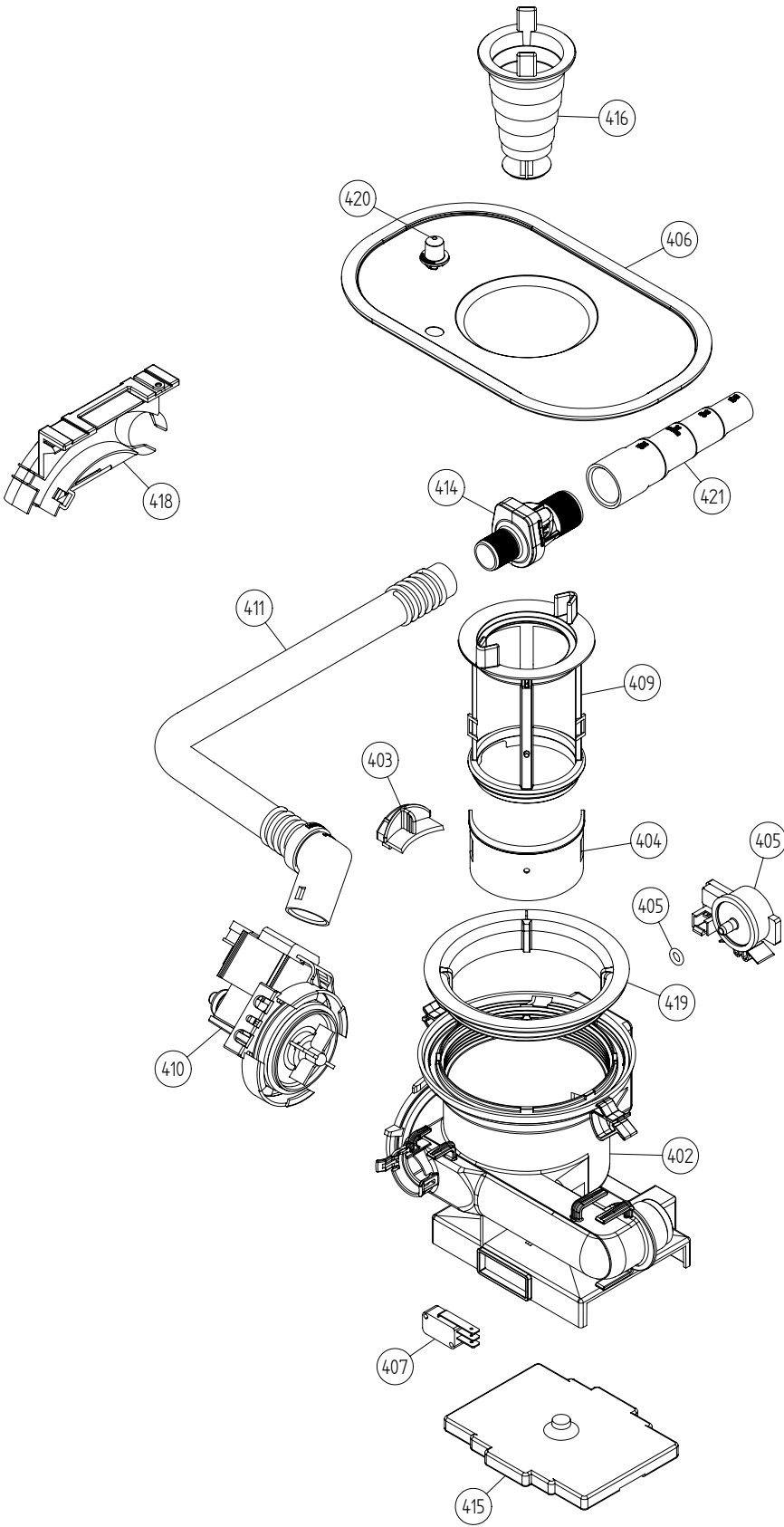

Bottom well and related parts

ASKO, D3252 US - Titanium FI (DW20.3)

Pos	Spare part No.	Description	Qty	Comment
402	8073691-77	Bottom Well Pressure Sensor	1 Pcs	
402-a	8073002	ORing	1 Pcs	
403	8057487-79	Sump Plug DW 05/06 Cleanout	1 Pcs	
404	8058454	Cover Str. Basket 05/06 DW	1 Pcs	
405	8073839	Pressure Sensor	1 Pcs	
405-a	8074040	ORing	1 Pcs	
406	8074364	STRAINER DW20	1 Pcs	
406	8074252	Use 8074364	1 Pcs	
407	8073835	MICROSWITCH FLOAT	1 Pcs	
409	8073396-77	INSERT STRAINER BASKET	1 Pcs	
410	8073818	Drain Pump	1 Pcs	
410-a	8002584	ORing Drain Pump 05/06 DW	1 Pcs	
411	8074030	Outlet Hose	1 Pcs	
411-a	8052239	Hose Clamp Squeeze	1 Pcs	
411-b	8052430	Cable Strip	1 Pcs	
414	8801248	Check Valve Kit	1 Pcs	
414-a	8052239	Hose Clamp Squeeze	1 Pcs	
414-b	8053642	Hose Clip	1 Pcs	
415	8075110	FLOAT	1 Pcs	
416	8057972-77	Strainer Basket Grey 05/06 DW	1 Pcs	
418	8072528-77	Holder Outlet Hose	1 Pcs	
418-a	8053642	Hose Clip	1 Pcs	
418-b	8052239	Hose Clamp Squeeze	1 Pcs	
418-c	33700450	Cable Strip	1 Pcs	
418-d	8902072	Screw	1 Pcs	
419	8072848	Lockring Bottom Well	1 Pcs	
420	8074760-77	Ventilator	1 Pcs	
421	8075321	End Cuff	1 Pcs	

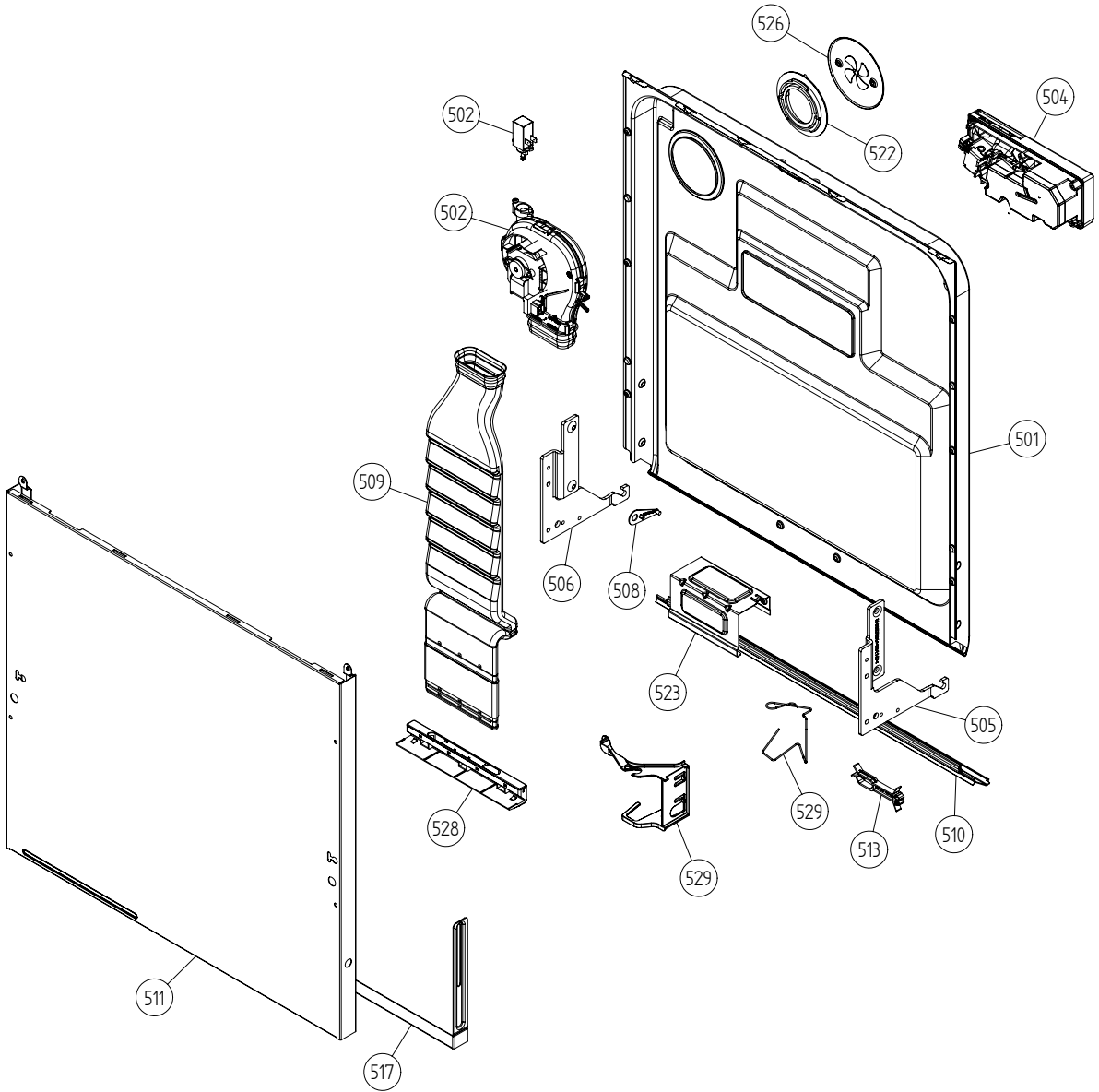

Inner door, panel and related parts

ASKO, D3252 US - Titanium FI (DW20.3)

Pos	Spare part No.	Description	Qty	Comment
501	8801246	Door Inner w/Insul. Int. Fan	1 Pcs	
501-a	8900646	Screw 20 Torx SS	6 Pcs	
501-b	8902121	Screw	4 Pcs	
502	8073851	Fan Complete 120V	1 Pcs	
502-a	8058501	ORing Turbo Fan Dry 05/06 DW	1 Pcs	
502-b	8052778	WAX MOTOR DW 05/06	1 Pcs	
504	8073803	Combdisp. Reed Reay 120V	1 Pcs	
504-a	8071916	Subs to 8071918	1 Pcs	
504-b	8071917	CAP RINSE AGENT	1 Pcs	
504-c	8071918	Detergent Lid Complete	1 Pcs	
504-d	8072288	Sealing Strip Combdisp.	1 Pcs	
504-f	8902087	Screw Plastic Housing 20 Torx	6 Pcs	
505	8057524	Hinge Right DW 05/06	1 Pcs	
505-a	8057530	Screw hinge 05	1 Pcs	
505-b	33500262	Nut Term Block	1 Pcs	
506	8057525	Hinge left DW 05/06	1 Pcs	
506-a	8057530	Screw hinge 05	1 Pcs	
506-b	33500262	Nut Term Block	1 Pcs	
507	8057530	Screw hinge 05	2 Pcs	
507-a	33500262	Nut Term Block	2 Pcs	
508	8057948	Slide washer hinge bearing 05	2 Pcs	
509	8057963-P	Air Channel Adj. 1895 FI	1 Pcs	
510	8060254	Lower SealInner Door 05/06 DW	1 Pcs	
511	8074801-PT-81	DOOR OUTER INT ADJUST GREY	1 Pcs	
511-a	8900646	Screw 20 Torx SS	6 Pcs	
513	8074015	CABLE BRACKET DOOR	1 Pcs	
517	8074012-81	Adj. Frame Air Channel	1 Pcs	
517-a	8902133	SCREW MRT-GF M5x8 COMB T25 FZB	2 Pcs	
522	8057964	Locking ring turbo fan 05	1 Pcs	
522-a	8902085	Screw 20T for Plastic	2 Pcs	
523	8057985	Outer Door Lower Stay 05/06 DW	1 Pcs	
523-a	8900646	Screw 20 Torx SS	2 Pcs	
523-b	8902357	Screw	2 Pcs	
526	8058484	SS Coverplate Turbo Fan DW	1 Pcs	
526-a	8902085	Screw 20T for Plastic	2 Pcs	
528	8072732-33	Nozzle Air Duct	1 Pcs	
529	8073612	BRACKET FOR HARNESS	1 Pcs	
529	8074278	Bracket for harness	1 Pcs	

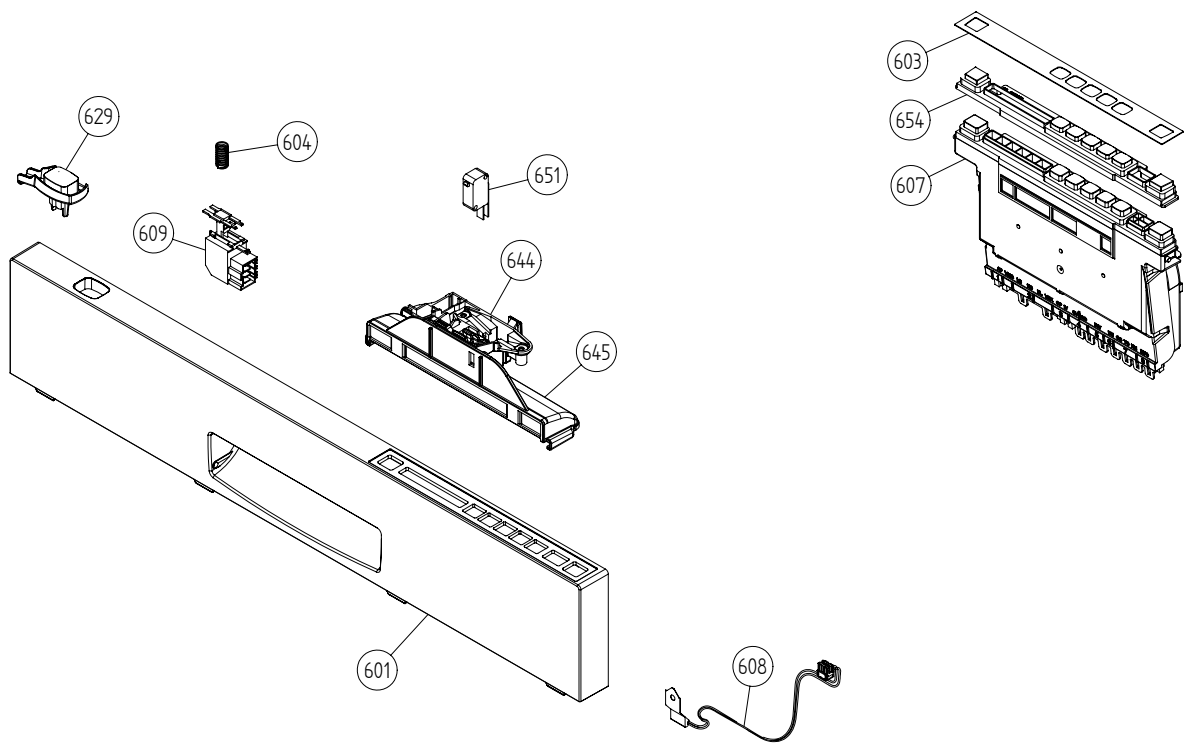

Control panel and related parts

ASKO, D3252 US - Titanium FI (DW20.3)

Pos	Spare part No.	Description	Qty	Comment
601	8077296-81-UL	PANEL ASKO 3252-345F GRPH. UL4	1 Pcs	
602	8075303	Prog. Info. Label 3250345F US	1 Pcs	
602	8075305	Prog. Info Label 345F3250 ES	1 Pcs	
602	8075345	Prog Info. Label 345F3250 FR	1 Pcs	
603	8074993	Decor Plate 345T/FI Graph	1 Pcs	
604	8074277	SPRING MAIN SWITCH	1 Pcs	
607	8801282	CONTROL.UNIT DW20.3 US F.DISH	1 Pcs	
608	8073788	Thermistor	1 Pcs	
608-a	8076839	thermistor spacer	1 Pcs	
609	8073782	MAIN PUSH SWITCH	1 Pcs	
611	8075740	Cable set 3000XL	1 Pcs	
614	8075736	cable set	1 Pcs	
616	8075735	CABLE SET FLOW & PRESSURE	1 Pcs	
618	8075738	cable set power	1 Pcs	
620	8075730	cable set fan	1 Pcs	
622	8075731	CABLE SET DRAIN	1 Pcs	
629	8075078-81	Push Button Main Switch Graphi	1 Pcs	
644	8073670	Lock Complete Integrated	1 Pcs	
645	8073666	HANDLE INTEGRATED LOCK	1 Pcs	
645-a	8072439	Bolt Tension Strap W600s	2 Pcs	
651	8073836	MICROSWITCH DOOR	0 Pcs	
654	8075719-81	Push Button 345 T/FI	1 Pcs	
690	8077172	INSTRUCTIONS D3252-345F US ENG	1 Pcs	
690	8077173	INSTRUCTIONS D3252-345F US FR	1 Pcs	
690	8077174	INSTRUCTIONS D3252-345F US ES	1 Pcs	

S:\UDW2011_Tryckunderlag\Kopplingsschema\8073809 Circuit diagram DW20.4_c.dft , mail , 2002-06-18 08:34:08

This document must not be copied without our written permission, and the contents thereof must not be imparted to a third party without the prior written consent and approval of Askocylinda AB.

CD: COMBI DISPENSER
 CP: CIRCULATION PUMP
 DIV: WATER DIVERTER VALVE
 DP: DRAIN PUMP
 DR: DOOR
 DS: DOOR SWITCH
 F: FILTER
 FM: FLOW METER
 FN: FAN
 FS: FLOAT SWITCH
 HE: HEATING ELEMENT
 HL: HALOGEN LAMP
 HS: HUMIDITY SENSOR
 IS: ILLUM. SWITCH
 IV: INLET VALVE
 MS: MAIN SWITCH
 PS: PRESSURE SENSOR
 RAS: RINSE AID SENSOR
 SS: SALT SENSOR
 SV: SALT VALVE
 TH: THERMISTOR
 TS: TURBIDITY SENSOR
 VAX: VAX ACTUATOR
 NET: INTERFACE TO HOME NET COMMUNICATION UNIT

— WIRES IN ALL MACHINES
 - - - INTERNAL CONNECTION
 - · - WIRES IN SOME MACHINES

RESISTANCES AT ROOM TEMPERATURE (CA. 20°C/68°F)
VALUES WITH +/-10% ARE REGARDED AS NORMAL

COMPONENT	RESISTANCE
RADIO INTERFERENCE SUPPRESSION FILTER	1 MOHM
HEATING ELEMENT 1400W 120V	12 OHM
HEATING ELEMENT 1800W 230V	30 OHM
THERMISTOR	25 KOHM
COMBINED DISPENSER 120V	0.3 KOHM
COMBINED DISPENSER 230V	1,3 OHM
CIRCULATION PUMP 120V 60HZ	22 OHM
CIRCULATION PUMP 230V 50HZ	90 OHM
CIRCULATION PUMP 220V 60HZ	56 OHM
DRAIN PUMP 120V 60HZ	25 OHM
DRAIN PUMP 230V 50HZ	150 OHM
DRAIN PUMP 230V 60HZ	85 OHM
SPRAY ARM DIVIDER 120V 60HZ	2.6 KOHM
SPRAY ARM DIVIDER 230V 50/60HZ	8,5 KOHM
INLET VALVE SINGLE INCL. FLOW SENSOR 120V	0.95 KOHM
INLET VALVE SAFETY INCL. FLOW SENSOR 120V	0.5 KOHM
INLET VALVE WATER SOFTNER INCL. FLOW SENSOR 120V	0.95 KOHM
INLET VALVE SINGLE INCL. FLOW SENSOR 230V	3,8 KOHM
INLET VALVE SAFETY INCL. FLOW SENSOR 230V	2 KOHM
INLET VALVE WATER SOFTNER INCL. FLOW SENSOR 230V	3,8 KOHM
HALOGEN LAMP 5W 12V	<10 KOHM
WAX MOTOR	1.1 KOHM
FAN MOTOR 120V	0.18 KOHM
FAN MOTOR 230V	0,75 KOHM

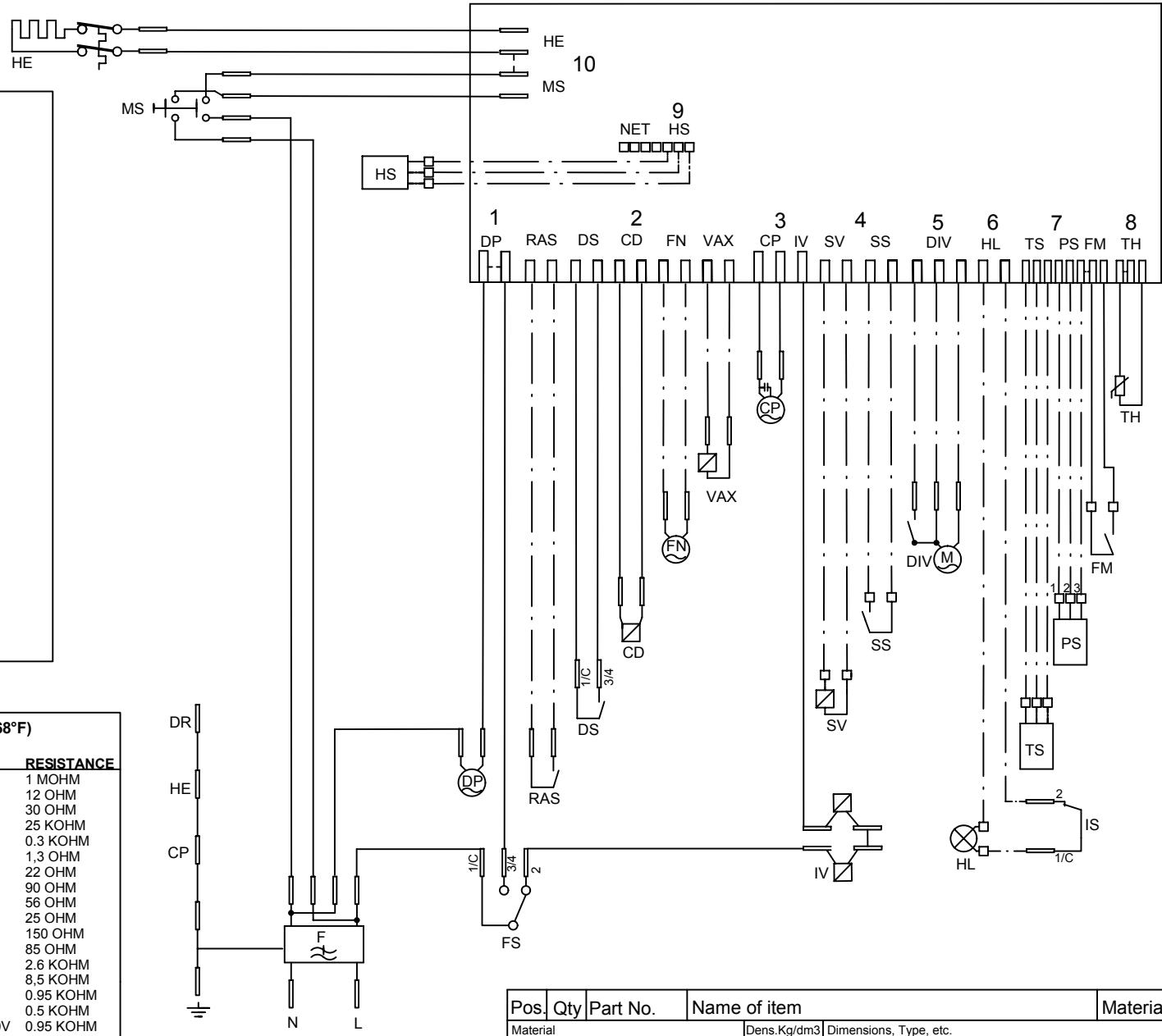

Pos.	Qty	Part No.	Name of item	Material
Material		Dens.Kg/dm3	Dimensions, Type, etc.	
Scale	1:1	Gen.tolerance	Description(ENG) CIRCUIT DIAGRAM DW20.1, .2, .3, .4, .C	
Designed by	ML	Gen.tol.Angle	Description(SE) KOPPLINGSSCHEMA DW20.1, .2, .3, .4, .C	
Released by	UD	Iss by Dept	Year	Week
		00	00	41
ASKO CYLINDA			80 738 09	00
			Rev Ind	Replace
				Project

Rev ind	Revision	Appd	Year	Week

Displays

DW20.1

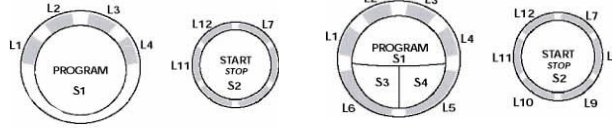

Panel type DW20.1, L = LED, S = Push-button

DW20.2



Panel type DW20.2, L - LED, S - Push-button, D - Display

DW20.3



Panel type DW20.3, L - LED, S - Push-button

DW20.4



Panel type DW20.4, L - LED, S - Push-button

TOTAL RESET

- TURN OFF MAIN SWITCH
- WAIT FOR AT LEAST 5 SECS
- HOLD PROGRAM BUTTON (S1)
- TURN ON MAIN SWITCH
- RELEASE PROGRAM BUTTON (S1)

SERVICE MENU

- TURN OFF MAIN SWITCH
- WAIT FOR AT LEAST 5 SECS
- *HOLD PROGRAM AND START BUTTONS (S1 & S2)
- TURN ON MAIN SWITCH
- RELEASE PROGRAM AND START BUTTONS (S1 & S2)
- *FOR DW20.4 HOLD TEMPERATURE/SET AND DRYING/MENU (S3 & S4)

VARIANT SETTING

- *ACTIVATE THE SERVICE MENU
- PRESS START (S2) 3 TIMES WITHIN 5 SECS
- *FOR DW20.4
- HOLD PROGRAM AND START BUTTONS (S1 & S2)
- TURN ON MAIN SWITCH
- RELEASE PROGRAM AND START BUTTONS
- PRESS START (S2) 3 TIMES WITHIN 5 SECS

COMPONENT TEST:

First enter Service menu.

DW20.1

No component test available.

DW20.2 and DW20.3

Component test:

Press the Programme button (S1) and index through the following components:

1. Inlet valve
2. Salt valve (only machines with water softener)
3. Detergent and surfactant dispenser
4. Circulation pump
5. Heating element and circulation pump (Max 75°C)
6. Fan
7. Drain pump

DW20.4

First enter service menu.

Press Drying/Menu (S4) to access component diagnostics.

Press Temperature/Set (S3) to activate the following components:

1. Inlet valve (display shows water intake volume)
2. Salt valve (only machines with water softener)
3. Detergent and surfactant dispenser
4. Circulation pump (display shows turbidity in Volts)
5. Heating element and circulation pump (Max 75°C)
6. Fan (display shows humidity sensor value)
7. Drain pump (display shows pressure sensor reading; 0.5-3.5 VDC)

Pos.	Qty	Part No.	Name of item	Material
Material		Dens.Kg/dm3	Dimensions, Type, etc.	
Scale	1:1	Gen.tolerance	Description(ENG) CIRCUIT DIAGRAM DW20.1, .2, .3, .4, .C	
Designed by	ML	Gen.tol.Angle	Description(SE) KOPPLINGSSCHEMA DW20.1, .2, .3, .4, .C	
Released by	UD	Iss by Dept	Year	Week
			00	41
ASKO CYLINDA			80 738 09	Rev Ind 00
				Replace
				Project

Rev ind	Revision	Appd	Year	Week
---------	----------	------	------	------