

**ASKO**  
BUILT TO LAST LONGER

## Spare Parts Catalogue

Type: DW90.2  
Model: D5638 XL US Stainless

Prod. No: 107563881  
February 4th 2013

**ASKO Appliances Inc.**

4001 E Plano Parkway #100  
4001 E Plano Parkway #100  
Plano, Texas 75074

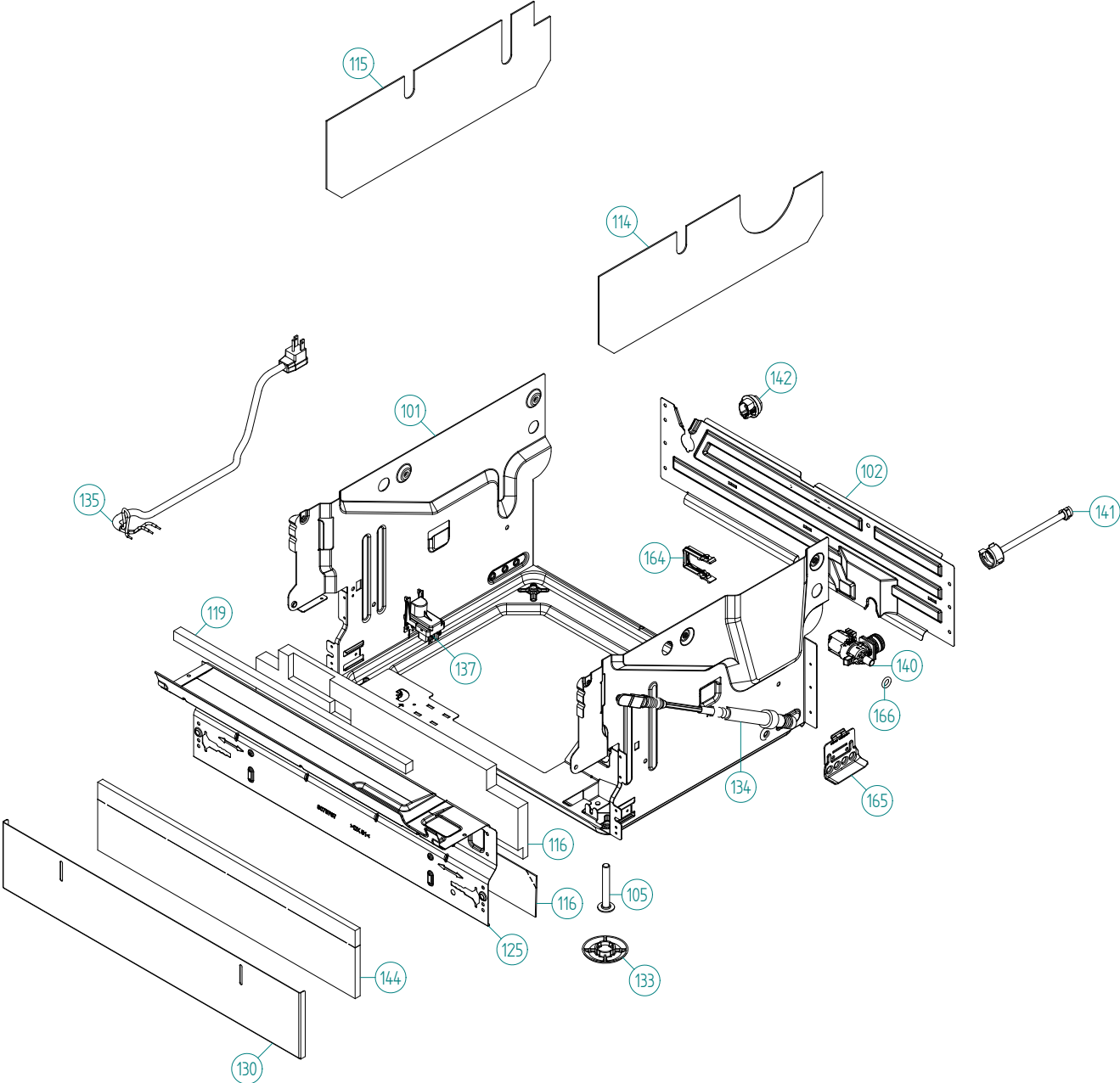

## Base and related parts

### ASKO, D5638 XL US - Stainless (DW90.2)

Pos	Spare part No.	Description	Qty	Comment
101	8801387	BOTTOM OUTER COMPL.	1 Pc's	
101-a	8901104	Screw 20 Torx Machine	2 Pc's	
101-b	8901110	Screw w/ORing DW 05/06 25T	4 Pc's	
102	8078006	REAR PANEL	1 Pc's	
102-a	8902357	Screw RTS 4.2X13 FZB T20	4 Pc's	
105	8089196	FOOT M10X75 PLASTIC EMBEDMENT	3 Pc's	
114	8078109	SOUND ABSORP. SELF AD. RIGHT	1 Pc's	
115	8078108	SOUND ABSORP. SELF AD. LEFT	1 Pc's	
116	8078114	SOUND ABSORBENT GUARD PLATE	1 Pc's	
116	8082272	Sound Absorb Protective Plate	1 Pc's	
119	8078122	SOUND ABSORPTION PROFILE	1 Pc's	
125	8078007-81	GUARD PLATE FLANGED TITANIUM	1 Pc's	
125-a	8902357	Screw RTS 4.2X13 FZB T20	4 Pc's	
130	8079572-81	KICK-PLATE FIXED DEPTH TITAN.	1 Pc's	
130	8079572	KICK-PLATE FIXED DEPTH	1 Pc's	
130-a	8900256	SCREW RXS 4,2X9,5 FZB	2 Pc's	
134	8088591	DOORSRING CPL HARD DAMPER YEL	1 Pc's	
134	8088592	DOORSRING CPL HARD DAMPER RED	1 Pc's	
135	8083262	CORD SET 15A AMERICA	1 Pc's	
137	8083041	Terminal Block w/RFI DW70	1 Pc's	
137-a	8901097	Screw Terminal	1 Pc's	
140	8801376	KIT INL.VALVE/LOCKARM SING120V	1 Pc's	
141	8079522	PEX Inlet hose DW	1 Pc's	
141-a	8074473	SEALING EPDM 13X9,1	1 Pc's	
141-b	8090072	SEAL 3/4 EPDM 25,9X10,9X2	1 Pc's	
142	8006948	Grommet	1 Pc's	
144	8089570	Sound Absorb Toe Kick	1 Pc's	
164	8079597	LOCK ARM INLET VALVE	1 Pc's	
165	8078013	DOOR SPRING HOLDER	2 Pc's	
165-a	8902362	SCREW RTK ST 4,2X9,5 FZB WAX.	2 Pc's	
166	8901779	O-RING 10X3,5	1 Pc's	

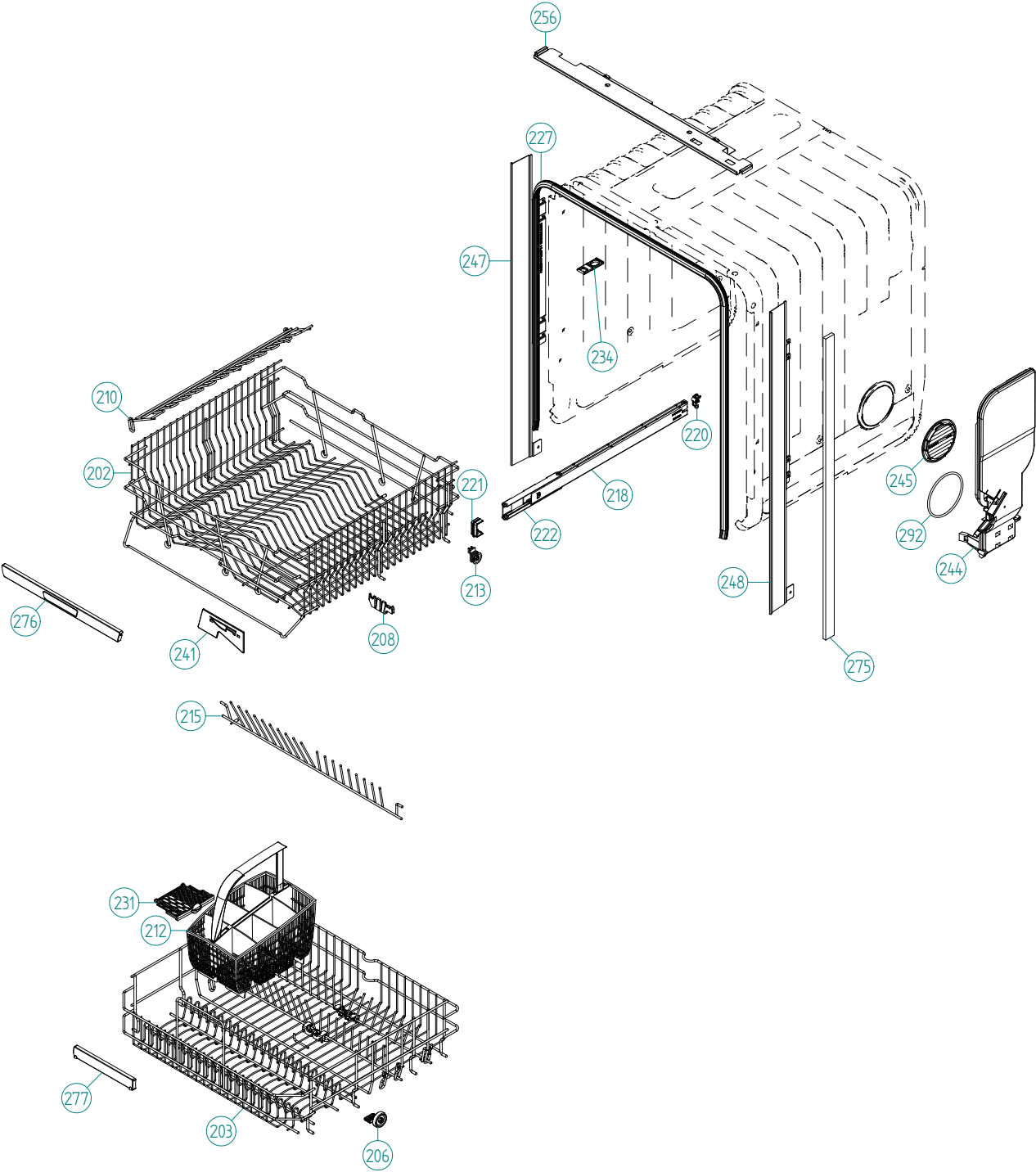

## Baskets and related parts

### ASKO, D5638 XL US - Stainless (DW90.2)

Pos	Spare part No.	Description	Qty	Comment
201	8057056	-	1 Pc's	Not a spare part
202	8801315-36	UPPER BASKET EXCL. CPL D.GREY	1 Pc's	
203	8801316-36	LOWER BASKET EXCL D.GREY 07	1 Pc's	New design
206	8079257-77	WHEEL FOR LOW DISHW BASKET CPL	8 Pc's	
208	8071214-77	Knife Holder 05/06 DW	2 Pc's	
210	8071337-36	Cup Shelf Wine Glass 05/06 DW	2 Pc's	
212	8801396-77	Cutlery Bskt for Stnd Tines	1 Pc's	
213	8058498-77	Upper Basket Wheel	4 Pc's	
215	8079122-36	PLATERACK D-GREY	2 Pc's	
218	8801350	DW Upper Basket Guide Rail Kit	2 Pc's	
220	8057978-77	DW Rail Stop - Back Grey	2 Pc's	
221	8088703-77	BASKET STOP	2 Pc's	
222	8801349-77	Bearing Holder w/Bearings	1 Pc's	
227	8057489-E	Door strip 3000xl	1 Pc's	
231	8079251-77	DOOR CUTLERYBASKET UL4	1 Pc's	
234	8070649	Lock Hitch Int	1 Pc's	
234-a	8070654	LOCK WASHER INTEGR.	1 Pc's	
234-b	8901104	Screw 20 Torx Machine	1 Pc's	
241	8057506-77	Knife Stop	1 Pc's	
244	8078300	AIRBREAK STD. DW70 UL4	1 Pc's	
245	8078304-77	Lockring Air Break Grey	1 Pc's	
247	8074342-E-90	TRIM STRIP LEFT XXL SS	1 Pc's	
248	8074343-E-90	Trim Strip Right XXL SS	1 Pc's	
256	8075663-90	TRIM RAIL LOW USA STAINLESS	1 Pc's	
275	8070614	SEALING STRIPE TRIM STRIPE USA	2 Pc's	
276	8801330-77	HANDLE U-BASKET COMPL. ASKO	1 Pc's	
277	8801332-77	HANDLE LOWER BASKET COMPL.	1 Pc's	
292	8901778	O-RING 95X4	1 Pc's	

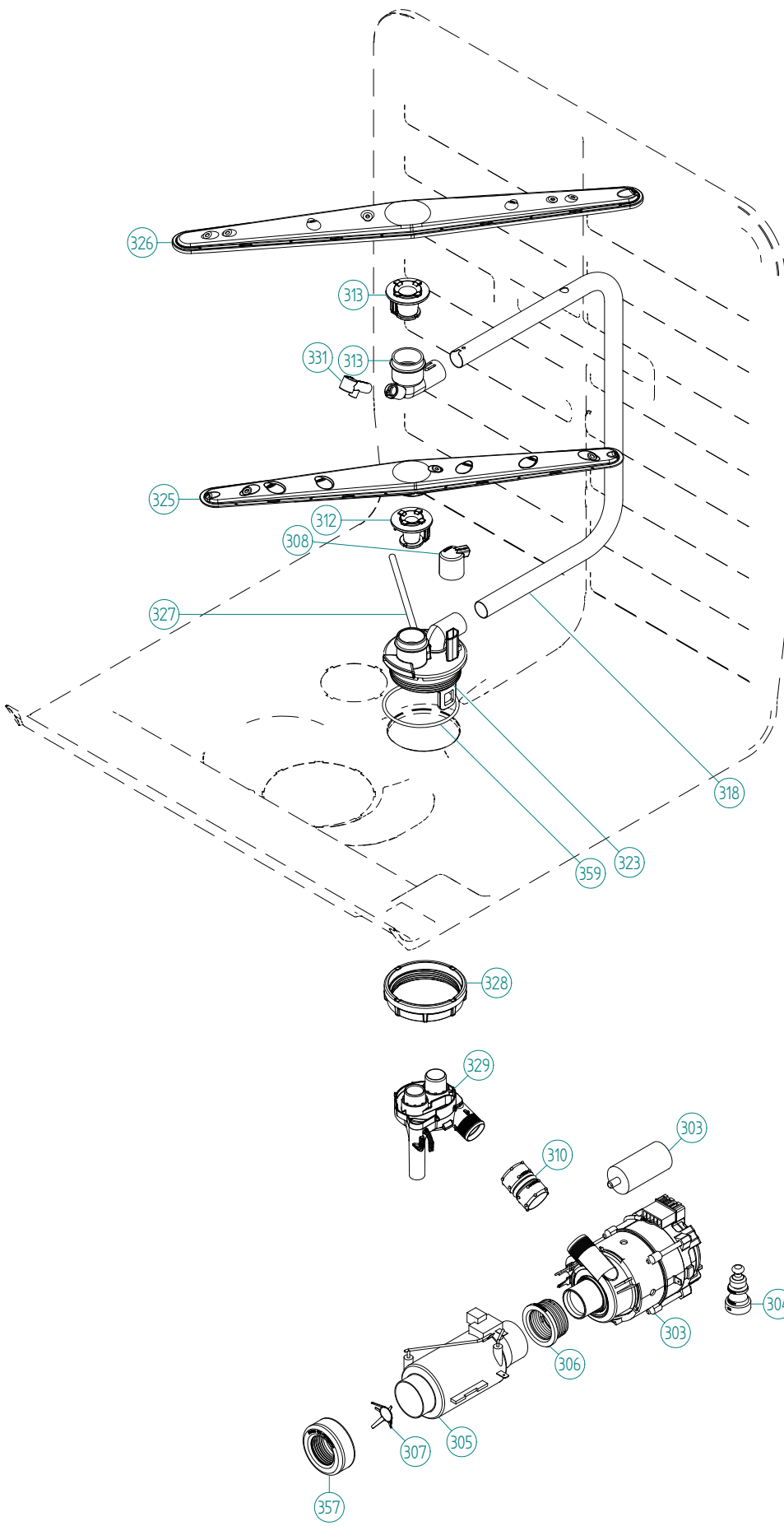

## Wash System

### ASKO, D5638 XL US - Stainless (DW90.2)

Pos	Spare part No.	Description	Qty	Comment
301	8077998	-	1 Pc's	Not to be ordered
303	8078082	CIRC.PUMP 120V 60HZ	1 Pc's	
303-a	8083804	Capacitor 7 0UF 400V P2 CLASS	1 Pc's	
304	8079683	RUBBER DAMPER HI CIRC.PUMP UL4	1 Pc's	
305	8801463	HEATER W.INSERT 1200W120V DW70	1 Pc's	
306	8083603	Seal Heating Element DW70/90	1 Pc's	
307	8079575	INSERT FOR HEATER	1 Pc's	
308	8073385-77	Cup Drainage Gray	1 Pc's	
310	8801409	KIT HOSE INCL.CLAMPS CIRK.PUMP	1 Pc's	
312	8801270	Spray Arm Bearing Kit	1 Pc's	
313	8801268	Spray Arm Bearing Kit	1 Pc's	
313	8801268	KIT SPRAYARM BEAR. UPPER DW20	1 Pc's	
318	8073387	Spray Pipe	1 Pc's	
323	8801270	KIT SPRAYARM BEAR. LOW NOZZLE	1 Pc's	
325	8072891	Spray Arm Lower Complete	1 Pc's	
326	8072894	Spray Arm Upper Complete	1 Pc's	
327	8073381	Tube Pot Rinse	1 Pc's	
327-a	8902085	Screw 20T for Plastic	2 Pc's	
328	8071607	Locking Spray Pipe Bearing	1 Pc's	
329	8078086	INTERMEDIATE	1 Pc's	
331	8072543-77	Spray Nozzle	1 Pc's	For part no 8073381 and 8076902-L-77
357	8083603	Seal Heating Element DW70/90	1 Pc's	
359	8901765	ORing det Comp 03/04 DW	1 Pc's	

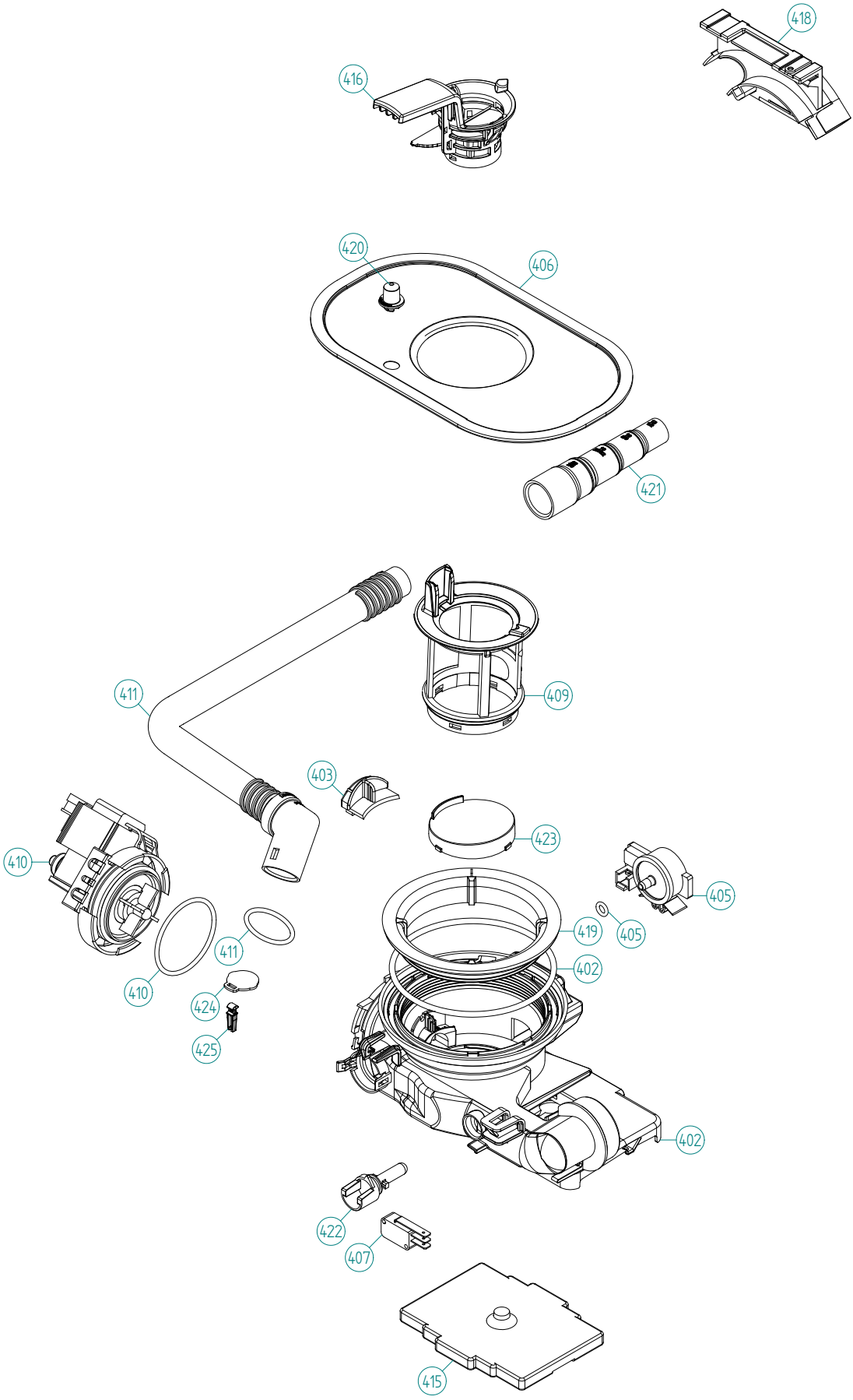



## **Bottom well and related parts**

### **ASKO, D5638 XL US - Stainless (DW90.2)**

<b>Pos</b>	<b>Spare part No.</b>	<b>Description</b>	<b>Qty</b>	<b>Comment</b>
402	8084691	BOTTOM WELL PRESSURE SENS. UL4	1 Pc's	
402-a	8081039	O-RING 110x4	1 Pc's	
403	8078033	Rinse Cap Bottom Well - Yellow	1 Pc's	
405	8073839	Pressure Sensor	1 Pc's	
405-a	8074040	O-Ring-Press Sensor	1 Pc's	
406	8074364	Strainer DW20	1 Pc's	
407	8073835	Microswitch Float	1 Pc's	
409	8078038-77	Pipe Filter DW70	1 Pc's	
410	8078089	Drain Pump 120V 60Hz	1 Pc's	
410-a	8002584	ORing Drain Pump 05/06 DW	1 Pc's	
411	8091596	OUTLETH. W HARDEND CUFF US UL4	1 Pc's	
411-a	8901768	O-RING 32,3X3 (BD)	1 Pc's	
415	8078025	Float	1 Pc's	
416	8078039-77	Strainer Basket Grey	1 Pc's	
418	8072528-77	Holder Outlet Hose	1 Pc's	
418-a	33700450	Cable Strip	1 Pc's	
418-b	8902072	SCREW PT KB40X10 WN1442 GALV	1 Pc's	
419	8072848	Lockring Bottom Well	1 Pc's	
420	8074760-77	Ventilator	1 Pc's	
421	8075321	End Cuff	1 Pc's	
422	8078096	Thermistor	1 Pc's	
423	8080827	BOTTOM LID TUBE FILTER	1 Pc's	
424	8079691	SEALING FLAT NON RETURN VALVE	1 Pc's	
425	8083211	HOOK NON RETURN VALVE	1 Pc's	

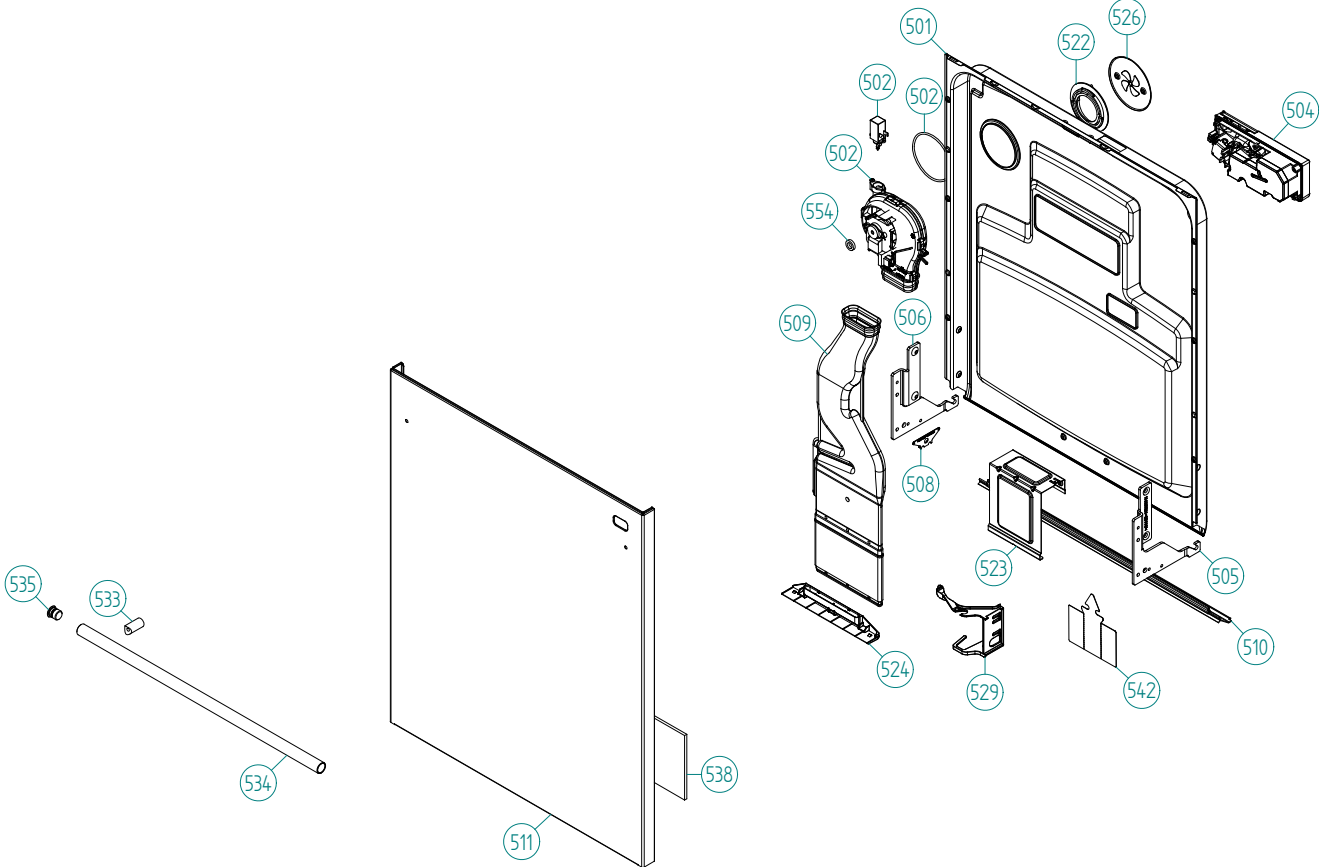

## Inner door, panel and related parts

### ASKO, D5638 XL US - Stainless (DW90.2)

Pos	Spare part No.	Description	Qty	Comment
501	8801410	DOOR INNER W.FAN DW70XL	1 Pc's	
502	8089580	Fan Complete 120v	1 Pc's	
502-a	8058501	ORing Turbo Fan Dry 05/06 DW	1 Pc's	
502-b	8801438	KIT WITH NEW WAXMOTOR DW	1 Pc's	
502-c	8902085	Screw 20T for Plastic	1 Pc's	
504	8083095	COMBIDISP AWECO REED 120V DW90	1 Pc's	
505	8089953	HINGE RIGHT PAINTED	1 Pc's	
506	8089952	HINGE LEFT PAINTED	1 Pc's	
507	8057530	Screw hinge 05	2 Pc's	
507-a	33500262	Nut Term Block	2 Pc's	
508	8088699	WASHER HINGE BEARING	2 Pc's	
509	8078040	Air Channel DW70	1 Pc's	
510	8801294	DOOR SEAL LOWER W.CORNER GUARD	1 Pc's	
522	8089401	LOCKKING RING 2 FAN HOUSE UL4	1 Pc's	
522-a	8902085	Screw 20T for Plastic	2 Pc's	
523	8057984	Push Button Grey 1706/1716 DW	1 Pc's	
523-a	8900646	Screw 20 Torx SS	2 Pc's	
523-b	8902357	Screw RTS 4.2X13 FZB T20	2 Pc's	
524	8083977-81	Air Pipe Thin Door Exp Dry Ti	1 Pc's	
526	8058484	SS Coverplate Turbo Fan DW	1 Pc's	
526-a	8902085	Screw 20T for Plastic	2 Pc's	
529	8074278	Bracket for harness	1 Pc's	
533	8075988	Crossbar handle 3000XL	2 Pc's	
534	8072435	Handle for 05/06 DW	1 Pc's	
534-a	8072439	Bolt Tension Strap W600s	2 Pc's	
535	8075836	End Plugs for Handle	1 Pc's	
535-a	8901774	ORing	1 Pc's	
538	8084400	INSULATION 240X130X5	1 Pc's	
542	8079686	COVER, CABLES DW70	1 Pc's	
554	8083885	SPACER FAN MOTOR-OUTER DOOR	1 Pc's	

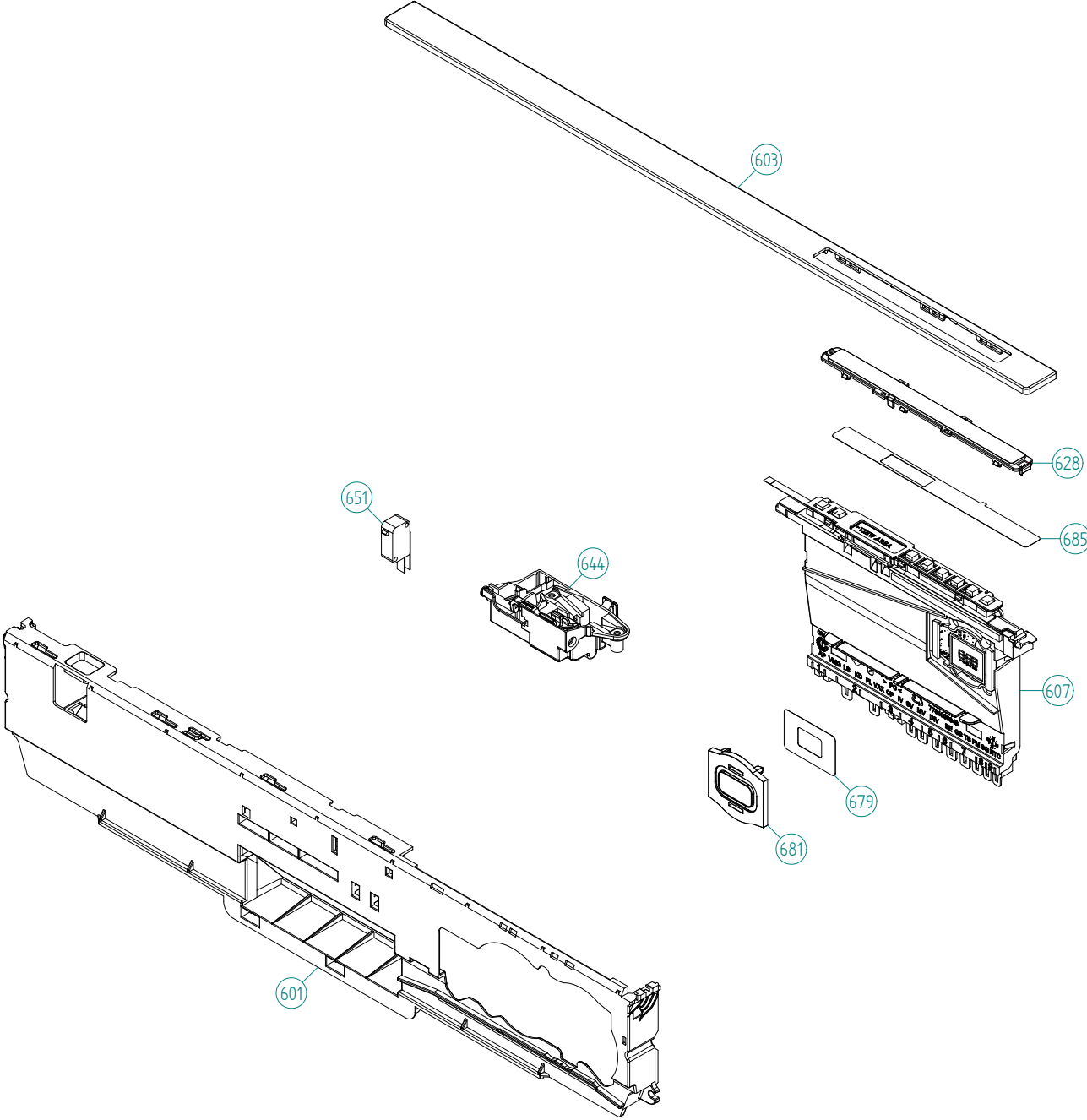

## Control panel and related parts

### ASKO, D5638 XL US - Stainless (DW90.2)

Pos	Spare part No.	Description	Qty	Comment
601	8084001-UL	PANEL DW90 INTEGRATED LOCK UL4	1 Pc's	
602	8090907	PROG.INFO.LABEL D5534,5634 FR	1 Pc's	
602	8091016	PROG.INFO.LABEL D5534,5634 ENG	1 Pc's	
603	8084046-81	LENS DW90.2 ASKO GRAPHIC	1 Pc's	
607	8801481	CONTR.UNIT CPL DW90.2 DISP W/B	1 Pc's	
610	8079517	CABLE SET THERMISTOR UL4	1 Pc's	
614	8078068	CABLE SET CI.PUMP IN.VALVE UL4	1 Pc's	
616	8078067	CABLE SET FLOW & PRESSURE UL4	1 Pc's	
618	8079511	CABLESET POWER TOUCH UL4	1 Pc's	
620	8084061	CABLE SET DOOR FAN-REED UL4	1 Pc's	
622	8095325	CABLE SET DRAIN FERR. DW90 UL4	1 Pc's	
628	8084019	TOUCH LENS DW90.2 UL4	1 Pc's	
644	8073670	Lock Complete Integrated	1 Pc's	
644-a	8902085	Screw 20T for Plastic	2 Pc's	
651	8073836	MICROSWITCH DOOR	0 Pc's	
679	8084048	Decor Insert Disp Window 90.2	1 Pc's	
681	8801478	DISPL.WINDOW INCL. TAPE DW90.2	1 Pc's	
685	8091975-69	DECOR INSERT DW90.2 3BU GR.UL4	1 Pc's	
690	8093949	INSTRUCTIONS D5638 XL ENG	1 Pc's	
690	8093950	INSTRUCTIONS D5638 XL FR	1 Pc's	

- KD/CD: COMBI DISPENSER
  - CP: CIRCULATION PUMP
  - DIV: WATER DIVERTER VALVE
  - AP/DP: DRAIN PUMP
  - DR: DOOR
  - LB/DS: DOOR SWITCH
  - F: FILTER
  - FM: FLOW METER
  - FL/FN 1: FAN DOOR
  - FAN/FN 2: FAN BOTTOM
  - FS: FLOAT SWITCH
  - EL/HE: HEATING ELEMENT
  - HE (PTC): HEATING ELEMENT PTC
  - BE/HL: HALOGEN LAMP
  - HS: HUMIDITY SENSOR
  - IS: ILLUM. SWITCH
  - IV: INLET VALVE
  - I2C: I2C
  - TB/MS: MAIN SWITCH
  - MV: MIX VALVE
  - TS/PS: PRESSURE SENSOR
  - VMG/RAS: RINSE AID SENSOR
  - SL: STATUS LIGHT
  - SG/SS: SALT SENSOR
  - SV: SALT VALVE
  - NTC/TH: THERMISTOR
  - GS/TS: TURBIDITY SENSOR
  - UART: UART
  - VAX: VAX ACTUATOR
  - HWC: HOT WATER CIRCUIT
- WIRES IN ALL MACHINES  
 - - - INTERNAL CONNECTION  
 - . - WIRES IN SOME MACHINES

**RESISTANCES AT ROOM TEMPERATURE (CA. 20°C/68°F)**  
**VALUES WITH +/-10% ARE REGARDED AS NORMAL**

COMPONENT	RESISTANCE
RADIO INTERFERENCE SUPPRESSION FILTER	1 MOHM
HEATING ELEMENT 1200W 120V	12 OHM
HEATING ELEMENT 1600W 230V	32 OHM
HEATING ELEMENT 2040W 230V	25 OHM
THERMISTOR	60 KOHM
COMBINED DISPENSER 120V	0,28 KOHM
COMBINED DISPENSER 230V	1,32 KOHM
CIRCULATION PUMP 120V 60HZ	32 OHM
CIRCULATION PUMP 230V 50HZ	110 OHM
CIRCULATION PUMP 220V 60HZ	56 OHM
DRAIN PUMP 120V 60HZ	25 OHM
DRAIN PUMP 230V 50HZ	150 OHM
DRAIN PUMP 230V 60HZ	85 OHM
SPRAY ARM DIVIDER 120V 60HZ	2,6 KOHM
SPRAY ARM DIVIDER 230V 50/60HZ	8,5 KOHM
INLET VALVE SINGLE INCL. 120V	0,95 KOHM
INLET VALVE SAFETY INCL. 120V	0,5 KOHM
INLET VALVE SINGLE INCL. 230V	3,9 KOHM
INLET VALVE SAFETY INCL. 230V	2 KOHM
SALT VALVE 120V	0,65 KOHM
MIX VALVE 120V	0,65 KOHM
SALT VALVE 230V	3 KOHM
MIX VALVE 230V	2,3 KOHM
HALOGEN LAMP 5W 12V	<10 KOHM
WAX MOTOR	1,1 KOHM
FAN MOTOR 120V	0,18 KOHM
FAN MOTOR 230V	0,85 KOHM
FAN MOTOR 2 120V	0,22 KOHM
FAN MOTOR 2 230V	0,90 KOHM

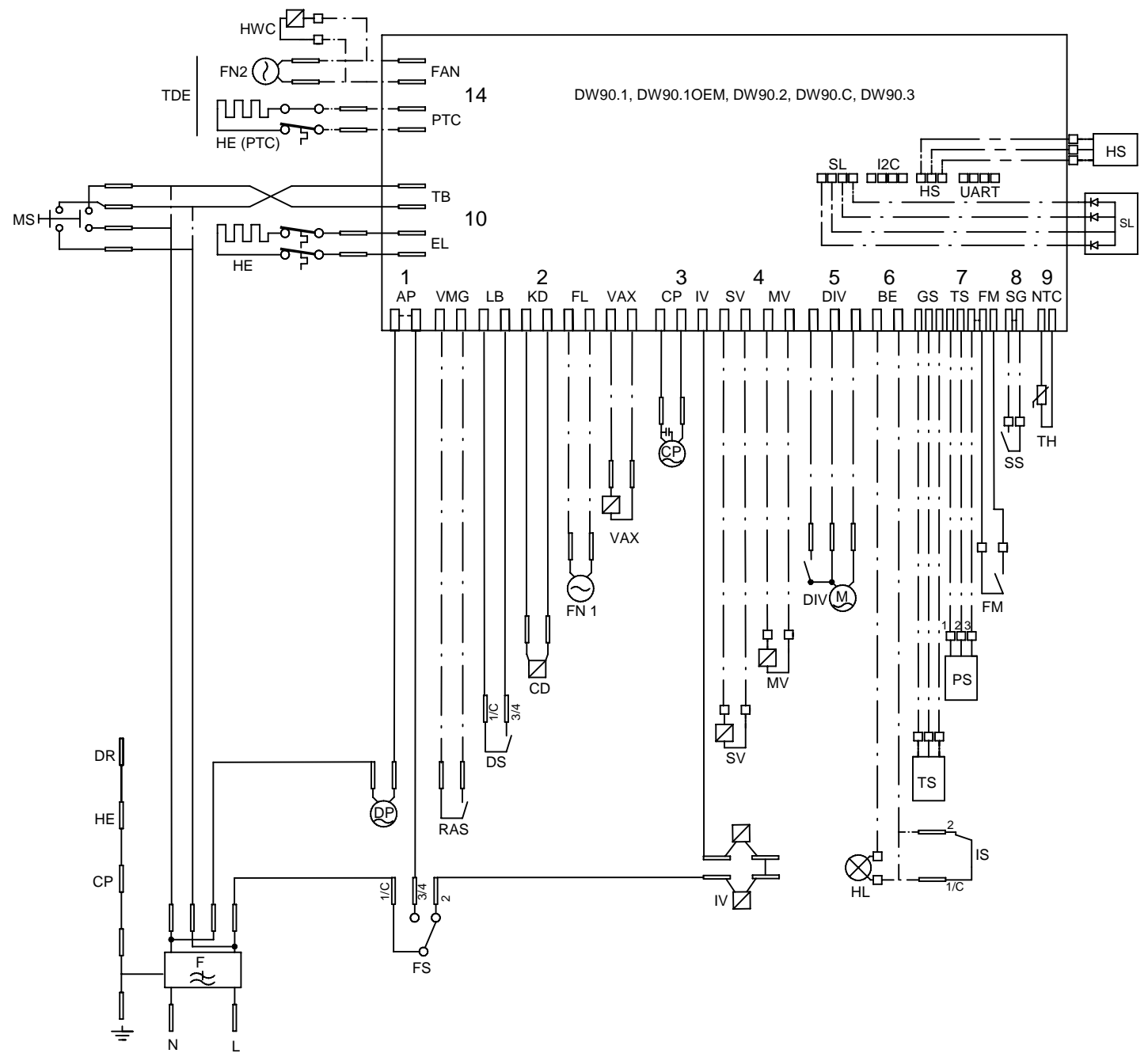

CIRCUIT DIAGRAM DW90.1, DW90.1OEM, DW90.2, DW90.C, DW90.3

80 840 68-01

This document must not be copied without our written permission, and the contents thereof must not be imparted to a third party nor be used for any unauthorized purpose. Contravention will be prosecuted. Asko Appliances AB

DW90.1, DW90.1 OEM, DW90.2		
After power on, wait until LCD is turned on. Then, within 5sec, press first T1 and directly after T2. Hold both buttons pressed during 5sec to enter service menu.		
Failure	F:XX	Last failure read out. F10 Overfilling, F11 Drain, F12 Water inlet, F40 Valve leakage, F41 Temp. stop, F42 Thermistor, F43 Pressure sensor, F44 Turbidity sensor, F45 Diverter
START (T2)		
Diagnostic	d:01	Mix valve and inlet valve on (1 sec delay between mixventil and inlet valve)
	d:02	Inlet valve on
	d:03	Salt Valve on
	d:04	Combi dispenser on
PROG (T1)	d:05	Circulation and spolarmsväxlaren (if available) shall alternate between positions 1 and 3 every 30 seconds
	d:06	Circulation and heaters - max 75 ° C
	d:07	Fan and vax actuator
	d:08	Drain Pump on
	d:00	No components on
START (T2)		
Water inlet	P:0	Normal water intake, default
	P:5	Water intake increased +5%
	P:10	Water intake increased +10%
PROG (T1)	P:15	Water intake increased +15%
	L:0	Time, flow meter disconnected, inlet time: no of pulses x 0.068 [s]
	L:5	Timed water intake increased +5%
	L:10	Timed water intake increased +10%
	L:15	Timed water intake increased +15%
START (T2)		
Variant, DW90.1	U:1 DW90.1	Variant 1 and 2, the default setting (temperature, drying)
	U:2 DW90.1 OEM	
	U:3 DW90.1	Variant 3 and 4 (Temperature, Drying, Delayed Start)
	U:4 DW90.1 OEM	
PROG (T1)	U:5 DW90.1	Variant 5 and 6 (Set of time program, Temperature, Drying, Time saving, Delayed Start)
	U:6 DW90.1 OEM	
	U:7 DW90.1 and DW90.1OEM	Variant 7 (Set of time program, Temperature, Drying, Time-saving, Upper Lower basket wash, Delayed Start)
Variant, DW90.2	U:1	Variant 1, the default setting (temperature, drying)
	U:2	Variant 2 (Temperature, Drying, Delayed Start)
PROG (T1)	U:3	Variant 3 (Temperature, Drying, Delayed Start, Set of time program)
	U:4	Variant 4 (Temperature, Drying, Delayed Start, Set of time program, Time saving)
START (T2)		
Region	EU	Region Europe, the default setting
PROG (T1)	US	Region USA
	AU	Region Australia
START (T2)		
Fan Sequence	Y:0	No fan sequence during wash cycle
PROG (T1)	Y:1	Fan sequence during the wash cycle but not in Normal program, the default setting
	Y:2	Fan in sequence during the all wash cycles
START (T1)		
TDE & HWC, only DW90.2	A:0	Turbo Drying Express and Heat Water Circuit off, default setting
PROG (T1)	A:1	Turbo Drying Express on
	A:2	Heat Water Circuit on
START (T2)		
ECO, only DW90.1	E:0	ECO off, the default setting
PROG (T1)	E:1	ECO on, when the machine is connected to hot water consumed less electrical energy to heat water and program time is shortened.
START (T2)		
Super rinse	S:0	Super Rinse, default
PROG (T1)	S:1	Super Rinse on. Adding two extra rinses.
START (T2)		
Total restart	r:0	No restart on the next press T2, default
PROG (T1)	r:1	Total restart at the next press T2
START (T2)		

DW90.3		
To enter service menu, press T1 and T2 at power on.		
START (T2)		
Failure	CU Date code xxxx	Control unit manufacturing date: year week
	Software xxx	Software version
PROG (T1)	3 FAIL. xxxx	Last failure
	2 FAIL. xxxx	2nd last failure
	1 FAIL. xxxx	3rd last failure
START (T2)		
Diagnostic	Testing	No component on
	Testing Valve A: XXX	Mix valve on and inlet valve on (1 sec delay between mix valve and inlet valve), flow in pulses(XXX) by flow meter
	Testing Valve B: XXX	Inlet valve on (1 sec delay), flow in pulses(XXX) by flow meter
PROG (T1)	Testing Salt	Salt valve on
	Testing Dispenser	Kombi dispenser on
	Testing Cir: XXV	Circulation pump on and the water diverter valve(if present) shall change between position 1 and 3 every 30 second, turbidity(XX) in Volt
	Testing Heater: XX°C	Circulation pump and heater on until max 75°C, temp displayed in °C or °F according to machine setup
	Testing Fan: XXXX	Fan and wax actuator on, humidity value(XXXX Hz)
	Testing TDE	TDE fan on and TDE heater on
	Testing Drain: XXV	drain pump on, pressure sensor value(XX) in Volt
START (T2)		
Water inlet	Water volume 0	Normal water intake, default
	Water volume +5%	Water intake increased +5%
	Water volume +10%	Water intake increased +10%
	Water volume +15%	Water intake increased +15%
PROG (T1)	Water volume Time 0	Time, flow meter disconnected, inlet time: no of pulses x 0.068 [s]
	Water volume Time +5%	Timed water intake increased +5%
	Water volume Time +10%	Timed water intake increased +10%
	Water volume Time +15%	Timed water intake increased +15%
START (T2)		
LCD-cont	Contrast 0	LCD-contrast 0
	Contrast +1	LCD contrast +1
PROG (T1)	Contrast +2	LCD contrast +2
	Contrast -1	LCD contrast -1
START (T2)		
TDE	Turbo Drying On	Turbo Drying Express On
PROG (T1)	Turbo Drying Off	Turbo Drying Express off
START (T2)		
Fan seq.	Fan Off	No fan sequence during wash cycle
PROG (T1)	Fan 1 On	Fan sequence during the wash cycle but not in Normal program, the default setting
	Fan 2 On	Fan in sequence during the all wash cycles
START (T2)		
DUO	DUO Off	DUO Off
PROG (T1)	DUO On	DUO On, to activate program like Sani, Pots & pans
START (T2)		
Region	Region EU	Region Europa, default setting
	Region US	Region USA
PROG (T1)	Region AU	Region Australien
START (T2)		

## Displays

### DW90.1

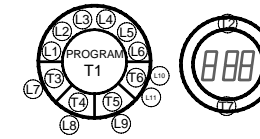

Panel type DW90.1, L = LED, T = Push-button

### DW90.1 OEM

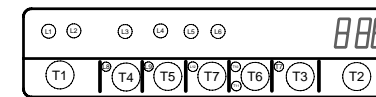

Panel type DW90.1 OEM, L = LED, T = Push-button

### DW90.2

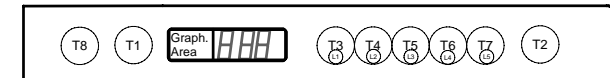

Panel type DW90.2, L = LED, T = Push-button

### DW90.3

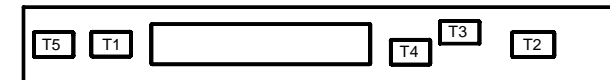

Panel type DW90.3, T = Touch areas

CIRCUIT DIAGRAM DW90.1, DW90.1OEM, DW90.2, DW90.C, DW90.3

80 840 68-01

This document must not be copied without our written permission, and the contents thereof must not be imparted to a third party nor be used for any unauthorized purpose. Contravention will be prosecuted. Asko Appliances AB