Comfort-Cire®

Century®

Owner's Manual

Room Air Conditioner

Cool Only

PTTC09A-1

PTTC12A-1

Cool w/Elect. Heat

PTTE09A-1

PTTE12A-1

Heat Pump

PTTH09A-1

PTTH12A-1



Contents

SAFETY PRECAUTIONS 3

IMPORTANT NOTE TO THE OWNER 7

IMPORTANT NOTE TO THE SERVICER..... 7

TRANSPORTATION DAMAGE 7

UNPACKING THE UNIT..... 7

OPERATING INSTRUCTIONS 7

INSTALLATION INSTRUCTIONS 8

WIRING 11

AIR CONDITIONER FEATURES..... 12

AUXILIARY CONTROLS-DIP SWITCHES..... 16

AIR CONDITIONER FEATURES..... 17

ADDITIONAL THINGS YOU SHOULD KNOW..... 21

WARRANTY..... 22

This appliance is not intended for use by persons (including children) with reduced physical, sensory or mental capabilities, or lack of experience and knowledge, unless they have been given supervision or instruction concerning use of the appliance by a person responsible for their safety. Children should be supervised to ensure that they do not play with the appliance.

 **WARNING**

HIGH VOLTAGE!
Disconnect ALL power before servicing or installing. Multiple power sources may be present. Failure to do so may cause property damage, personal injury, or death.

 **RECOGNIZE THIS SYMBOL AS A SAFETY PRECAUTION.**

ATTENTION INSTALLING PERSONNEL

As a professional installer you have an obligation to know the product better than the customer. This includes all safety precautions and related items.

Prior to actual installation, thoroughly familiarize yourself with this Instruction Manual. Pay special attention to all safety warnings. Often during installation or repair it is possible to place yourself in a position which is more hazardous than when the unit is in operation.

Instructions for installation and use of this product are provided by the manufacturer.

Remember, it is your responsibility to install the product safely and to know it well enough to be able to instruct a customer in its safe use.

Safety is a matter of common sense...a matter of thinking before acting. Most dealers have a list of specific good safety practices...follow them.

The precautions listed in this Installation Manual are intended as supplemental to existing practices. However, if there is a direct conflict between existing practices and the content of this manual, the precautions listed here take precedence.

EXPLANATION OF SYMBOLS



Indicates a hazardous situation that, if not avoided, will result in death or serious injury.



Indicates a hazardous situation that, if not avoided, could result in death or serious injury.



Indicates a hazardous situation that, if not avoided, may result in minor or moderate injury.



Indicates important but not hazard-related information, used to indicate risk of property damage.



Indicates a hazard that would be assigned a signal word WARNING or CAUTION.

Safety Precautions

To prevent injury to the user or other people and property damage, the following instructions must be followed. Incorrect operation due to ignoring of instructions may cause harm or damage. The seriousness is classified by the following indications.

WARNING	This symbol indicates the possibility of death or serious injury.
CAUTION	This symbol indicates the possibility of injury or damage to property.

- Meaning of symbols used in this manual are as shown below.

	NEVER DO THIS.
	ALWAYS DO THIS.

WARNING

Plug in power plug properly

- Otherwise, it may cause electric shock or fire due to excess heat generation.

Do not operate or stop the unit by inserting or pulling out the power plug.

- It may cause electric shock or fire due to heat generation.

Do not damage or use an unspecified power cord.

- If the power cord is damaged, it must be replaced by the manufacturer or an authorized service center in order to avoid hazard.

Do not modify power cord length or share the outlet with other appliances.

- It may cause electric shock or fire due to heat generation.

Do not operate with wet hands or in damp environment.

- It may cause electric shock.

Do not direct airflow at room occupants only.

- This could damage your health.

Always ensure effective grounding.

- Incorrect grounding may cause electric shock.

Do not allow water to run into electric parts.

- It may cause failure of machine or electric shock.

Always install circuit breaker and a dedicated power circuit.

- Incorrect installation may cause fire and electric shock.

Unplug the unit if strange sounds, smell, or smoke comes from it.

- It may cause fire and electric shock.

Do not use the socket if it is loose or damaged.

- It may cause fire and electric shock.

Do not open the unit during operation.

- It may cause electric shock.

Keep firearms away.

- It may cause fire.

Do not use the power cord close to heating appliances.

- It may cause fire and electric shock.

Do not use the power cord near flammable gas or combustibles, such as gasoline, benzene, thinner, etc.

- It may cause an explosion or fire.

Ventilate room before operating air conditioner if there is a gas leakage from another appliance.

- It may cause explosion, fire and burns.

Do not disassemble or modify unit.

- It may cause failure and electric shock.

Safety Precautions

CAUTION

- | | | |
|-----------------------------------------------------------------------------------------------------------------------------------------------------------------------------------------------------------------------------------------------|-----------------------------------------------------------------------------------------------------------------------------------------------------------------------------------------------------------------------------------------------|----------------------------------------------------------------------------------------------------------------------------------------------------------------------------------------------------------------------------------------------|
| <p> When the air filter is to be removed, do not touch the metal parts of the unit.</p> <ul style="list-style-type: none"> ● It may cause an injury. | <p> Do not clean the air conditioner with water.</p> <ul style="list-style-type: none"> ● Water may enter the unit and degrade the insulation. It may cause an electric shock. | <p> Ventilate the room well when used together with a stove, etc.</p> <ul style="list-style-type: none"> ● An oxygen shortage may occur. |
| <p> When the unit is to be cleaned, switch off, and turn off the circuit breaker.</p> <ul style="list-style-type: none"> ● Do not clean unit when power is on as it may cause fire and electric shock, it may cause an injury. | <p> Do not put a pet or house plant where it will be exposed to direct air flow.</p> <ul style="list-style-type: none"> ● This could injure the pet or plant. | <p> Do not use for special purposes.</p> <ul style="list-style-type: none"> ● Do not use this air conditioner to preserve precision devices, food, pets, plants, and art objects. It may cause deterioration of quality, etc. |
| <p> Stop operation and close the window in storm or hurricane.</p> <ul style="list-style-type: none"> ● Operation with windows opened may cause wetting of indoor and soaking of household furniture. | <p> Hold the plug by the head of the power plug when taking it out.</p> <ul style="list-style-type: none"> ● It may cause electric shock and damage. | <p> Turn off the main power switch when not using the unit for a long time.</p> <ul style="list-style-type: none"> ● It may cause failure of product or fire. |
| <p> Do not place obstacles around air-inlets or inside of air-outlet.</p> <ul style="list-style-type: none"> ● It may cause failure of appliance or accident. | <p> Ensure that the installation bracket of the outdoor appliance is not damaged due to prolonged exposure.</p> <ul style="list-style-type: none"> ● If bracket is damaged, there is concern of damage due to falling of unit. | <p> Always insert the filters securely. Clean the filter once every two weeks.</p> <ul style="list-style-type: none"> ● Operation without filters may cause failure. |
| <p> Do not use strong detergent such as wax or thinner but use a soft cloth.</p> <ul style="list-style-type: none"> ● Appearance may be deteriorated due to change of product color or scratching of its surface. | <p> Do not place heavy object on the power cord and ensure that the power cord is not compressed.</p> <ul style="list-style-type: none"> ● There is danger of fire or electric shock. | <p> Do not drink water drained from air conditioner.</p> <ul style="list-style-type: none"> ● It contains contaminants and could make you sick. |
| <p> Use caution when unpacking and installing. Sharp edges could cause injury.</p> | <p> If water enters the unit, turn the unit off at the power outlet and switch off the circuit breaker. Isolate supply by taking the power plug out and contact a qualified service technician.</p> | |

Safety Precautions

NOTICE The power supply cord with this air conditioner contains a current detection device designed to reduce the risk of fire. Please refer to the section Operation of Current Device, for details. In the event that the power supply cord is damaged, it cannot be repaired-it must be replaced with a cord from the Product Manufacturer.

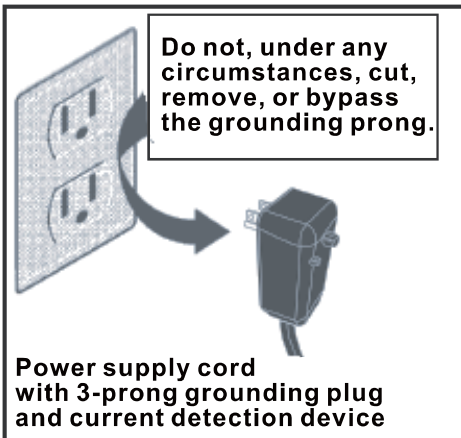

⚠ WARNING For your safety

- Do not store or use gasoline or other flammable vapors and liquids in the vicinity of this or any other appliance.
- Avoid fire hazard or electric shock. Do not use an extension cord or an adaptor plug. Do not remove any prong from the power cord.

⚠ WARNING Electrical Information

- Be sure the electrical service is adequate for the model you have chosen. This information can be found on the serial plate, which is located on the side of the cabinet and behind the grille.
 - Be sure the air conditioner is properly grounded. To minimize shock and fire hazards, proper grounding is important. The power cord is equipped with a three-prong grounding plug for protection against shock hazards.
 - Your air conditioner must be used in a properly grounded wall receptacle. If the wall receptacle you intend to use is not adequately grounded or protected by a time delay fuse or circuit breaker, have a qualified electrician install the proper receptacle.
 - Ensure the receptacle is accessible after the unit installation.
 - Do not run air conditioner without side protective cover in place. This could result in mechanical damage within the air conditioner.
- Do not use an extension cord or an adapter plug.**

Operation of Current Device

The power supply cord contains a current device that senses damage to the power cord. To test your power supply cord do the following:

1. Plug in the Air Conditioner.
2. The power supply cord will have TWO buttons on the plug head. Press the TEST button, you will notice a click as the RESET button pops out.
3. Press the RESET button, again you will notice a click as the button engages.
4. The power supply cord is now supplying electricity to the unit. (On some products this is also indicated by a light on the plug head.)

NOTES:

- Do not use this device to turn the unit on or off.
- Always make sure the RESET button is pushed in for correct operation.
- The power supply must be replaced if it fails reset when either the TEST button is pushed, or it cannot be reset. Please contact Customer Service.
- If power supply cord is damaged, it cannot be repaired. It **MUST** be replaced with a new cord - please contact Customer Service.

IMPORTANT NOTE TO THE OWNER

This equipment is to be serviced by professionally trained personnel only. If this equipment is improperly installed, adjusted or altered by an unqualified person, a safety hazard may result.

IMPORTANT NOTE TO THE SERVICER

Read this manual and familiarize yourself with the specific items which must be adhered to before attempting to service this unit. The precautions listed in this manual should not supersede existing practices but should be considered as supplemental information.

TRANSPORTATION DAMAGE

All units are securely packed in shipping containers approved by the National Safe Transit Association. The carton should be checked upon arrival for external damage. If damage is found, immediately make a written request for inspection by the carrier's agent.

In the event of damage:

1. Note on the delivery receipt any visible damage to shipment or container.
2. Notify carrier promptly and request an inspection.
3. File the claim with the following supporting documents within the six month statute of limitations.
 - a. Original Bill of Lading, certified copy, or indemnity bond.
 - b. Original paid freight bill or indemnity.
 - c. Original invoice or certified copy, showing trade and other discounts or reductions.
 - d. Copy of the inspection report issued by carrier's representative at the time damage is reported to the carrier.

The carrier is responsible for making prompt inspection of damage and for a thorough investigation of each claim. The distributor or manufacturer will not accept claims from dealers for transportation damage.

UNPACKING THE UNIT

1. Cut the carton banding and open the carton.
2. Remove the literature, hardware pack, upper styrofoam shipping blocks, and styrofoam corner posts.
3. Remove the front assembly.
4. Lift the unit from the remaining carton.
5. Dispose of the cardboard and styrofoam at an approved Recycle Center. Check all contents for damaged or missing parts. In case of concealed damage, notify the carrier as soon as possible—preferably within 5 days. Refer to step 3 of the Transportation Damage section if damage or missing parts are noted.

OPERATING INSTRUCTIONS

Check the data specification plate and ensure the proper voltage and current rating for the type of power plug on the unit is available. **DO NOT REMOVE THE GROUNDING PRONG FROM THE POWER CORD.** See Figure 1 for the types of acceptable plugs. Do not use an extension cord for the installation of this product. Refer to the data specification plate for electrical requirements.

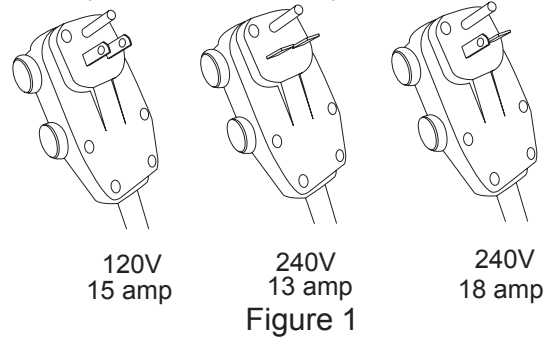

- LCDI or AFCI Power Cords - Underwrites Laboratories and the National Electric Code (NEC) now require power cords that sense current leakage and can open the electrical circuit to the unit on units rated at 250 volts or less. In the event that unit does not operate, check the reset button located on or near the head of the power cord as part of the normal troubleshooting procedure.

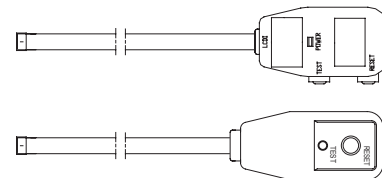

LCDI Power Cord

Note: Plug may be different than the actual product. Please refer to actual product.

VOLTAGE MEASUREMENTS

Before connecting the unit, measure the supply voltage. Voltage must fall within the voltage utilization range given in Table 1.

Operating Voltage		
Unit Voltage Rating	Voltage Utilization Range	
	Minimum	Maximum
230/208	187	253
115	103	126

Table 1
Operating Voltage



WARNING

To prevent electrical shock, property damage, personal injury, or death, do not remove grounding prong from plug. Follow all operating instructions.

INSTALLATION INSTRUCTIONS

To ensure that the unit operates safely and efficiently, it must be installed, operated, and maintained according to these installation and operating instructions and all local codes and ordinances, or, in their absence, with the latest edition of the National Electrical Code. The proper installation of this unit is described in the following sections. Following the steps in the order presented should ensure proper installation.

Sleeve installation

In order for condensate water to drain properly inside the unit, the sleeve must be installed properly:

- Level from right to left.
- A slight downward pitch from the indoor side to the outdoor side as shown in Figure 3.

Refer to the Installation Instructions supplied with the wall sleeve for a complete description of the installation procedure.

NOTE: Wall sleeve is not shipped with chassis and must be purchased separately.

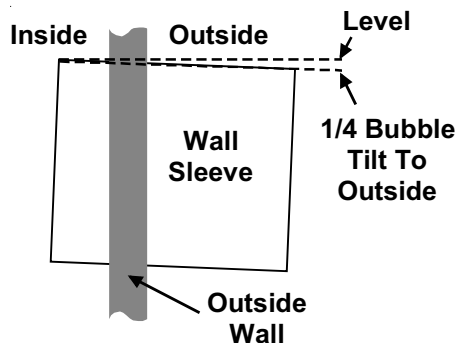

Figure 2

CHASSIS INSTALLATION

1. Remove front grille. See Figure A.

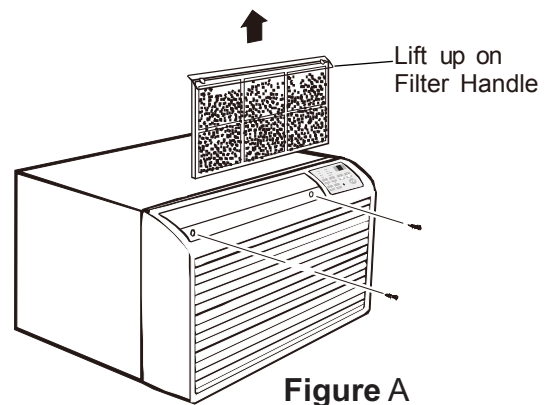
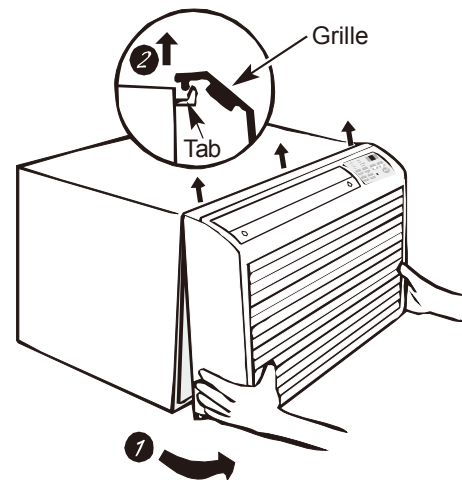

Figure A

The front grille can be removed for more thorough cleaning or to make the model and serial numbers accessible. To remove, pull the filter out and remove the two grille screws.



Pull the grille out from the bottom and lift up from the tabs on the top of the case.

2. Remove the grounding screw and wire next to the grounding symbol on right side of chassis control panel (Figure 3). Attach other end of ground wire to the hole in the bottom right side of the sleeve with #8 x 3/8" blunt point sheet metal screw. The hole on the sleeve is indicated by grounding symbol on the sleeve. Slide chassis part of the way into the sleeve and reattach the ground wire back to the hole on the right side on the control panel area next to the grounding symbol.

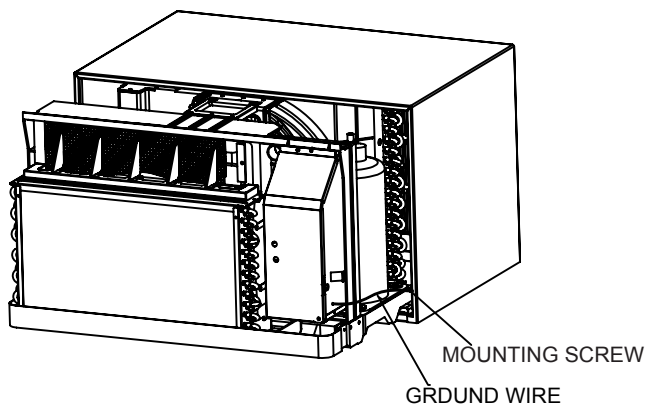

Figure 3

3. Remove shipping pads inside air conditioner next to compressor. (See Figure B.)

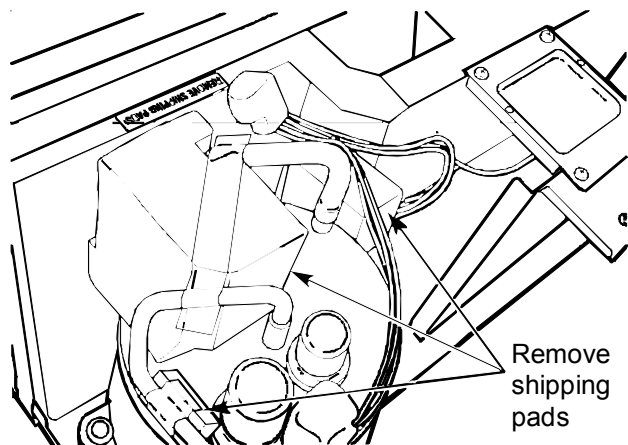

Figure B

4. Carefully slide the chassis into the sleeve. Ensure that the ground wire is not pinched or in the path of the condenser fan.
5. Loosen locking plate screw and rotate tab with tab behind wall case flange (See Figure C) then tighten locking plate screw.

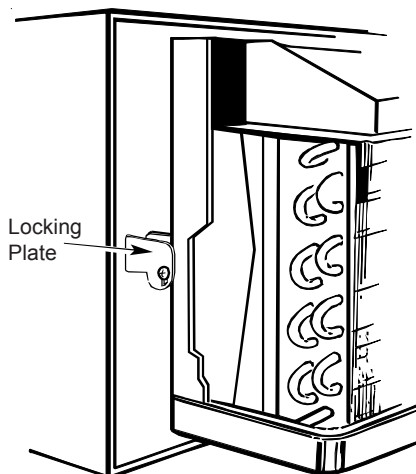

Figure C

6. If outlet is on the left side of the unit. route power cord as shown in Figure D.

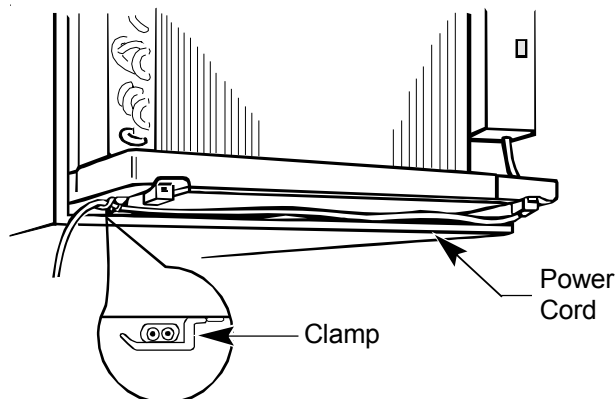
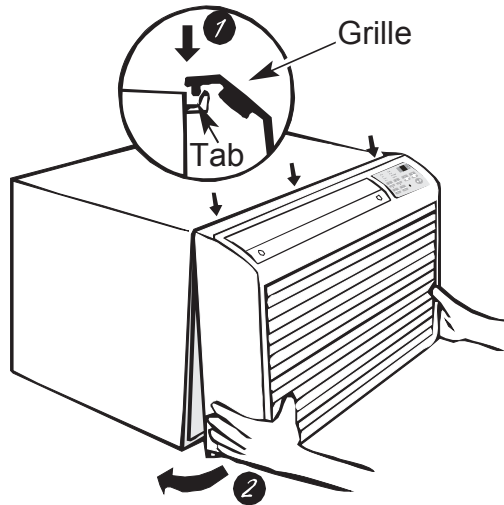

Figure D

To replace front grille:



Hook the tabs on the front grille even with the tabs on the case and snap into place. Replace the screws and filter. Refer to Page 2, Figure A.

VENT CONTROL AND AIR DIRECTION (See Figure E)
 The vent control is located behind the front grille on the right side of the air discharge area. When set at CLOSE only the air inside the room will be circulated and conditioned. When set at OPEN, some inside air is exhausted outside.

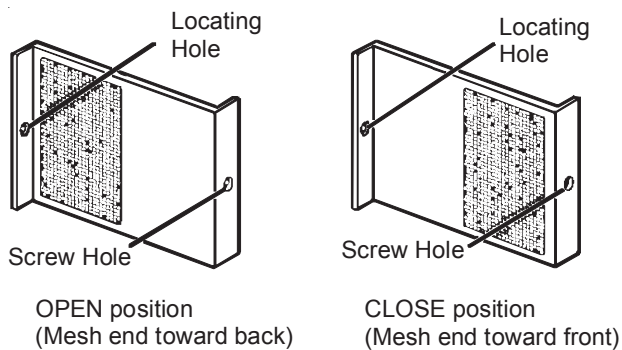

Figure E

To open or close the vent:

1. Remove the front grille.
2. Remove the vent card screw.
3. Remove the vent card, turn it over and replace it by locating rear hole in card over locating pin inside air discharge and reattaching screw at front.

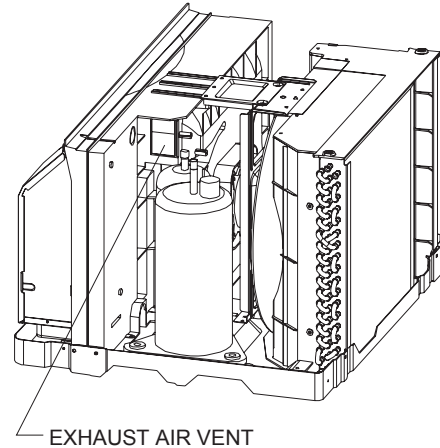
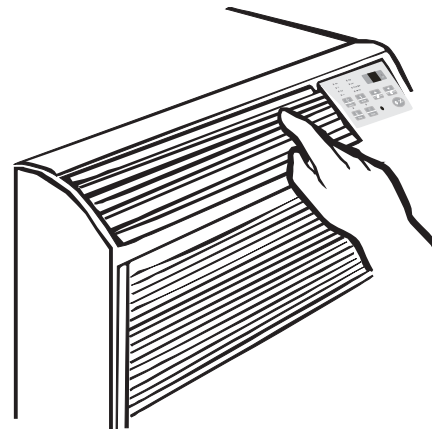

Figure 4

AIR DIRECTION:

Horizontal louvers on the front grille let you control the air direction up and down.



Remove the front grille to adjust the vertical louvers side-to-side to direct the air left or right.

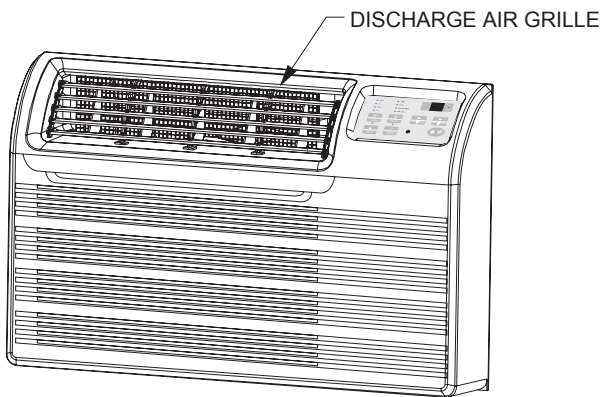
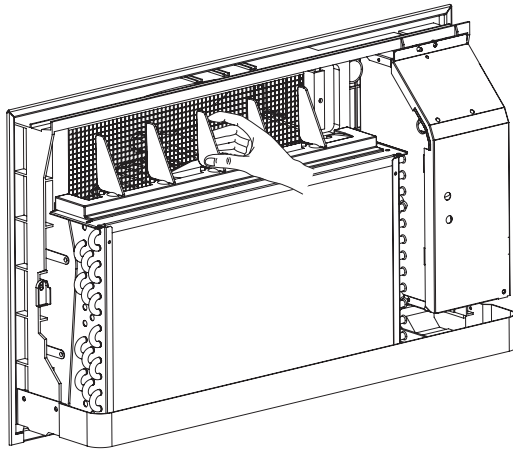

Figure 5

IMPORTANT NOTES:

1. The unit is equipped with a rubber-grommet-mounted compressor. These grommets are factory set and require no adjustment.
2. Obstruction to air flow must be checked and removed. Check the indoor and outdoor grilles for obstructions. The unit must be located where curtains, furniture, trees, or other objects do not block air flow to and from the unit. If air is obstructed and/or deflected back into the unit, the air conditioner's compressor may cycle on and off rapidly. This could cause damage to the compressor.

WIRING

Before wiring the unit, please review the following warnings and cautions.

! WARNING

To avoid the risk of electrical shock, personal injury or death, do not service this unit without first opening all disconnects and/or removing the unit cord set plug from the wall outlet.

! WARNING

To avoid the risk of electrical shock, personal injury, or property damage, do not use an extension cord with this unit.

! WARNING

To avoid the risk of fire, property damage, or personal injury, use only copper conductors.

! WARNING

To avoid the risk of personal injury, wiring to the unit must be properly polarized and grounded.

! WARNING

This air conditioner is not meant to provide unattended cooling or life support for persons or animals who are unable to react to the failure of this product.

The failure of an unattended air conditioner may result in extreme heat in the conditioned space causing overheating or death of persons or animals. Take proper precautions to avoid unattended operation.

AIR CONDITIONER FEATURES

ELECTRONIC CONTROL OPERATING INSTRUCTIONS

Before you begin, thoroughly familiarize yourself with the control panel and remote as shown below and all its functions. Then follow the symbol for the functions you desire. The unit can be controlled by the touch pad alone or with the remote.

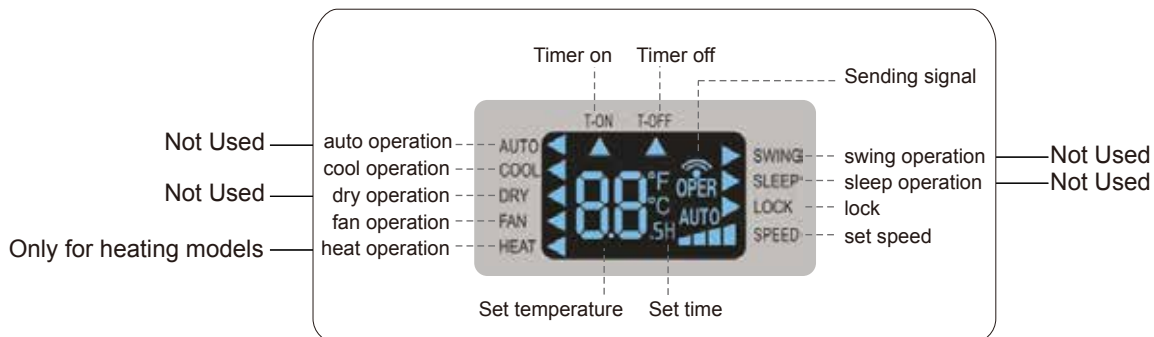
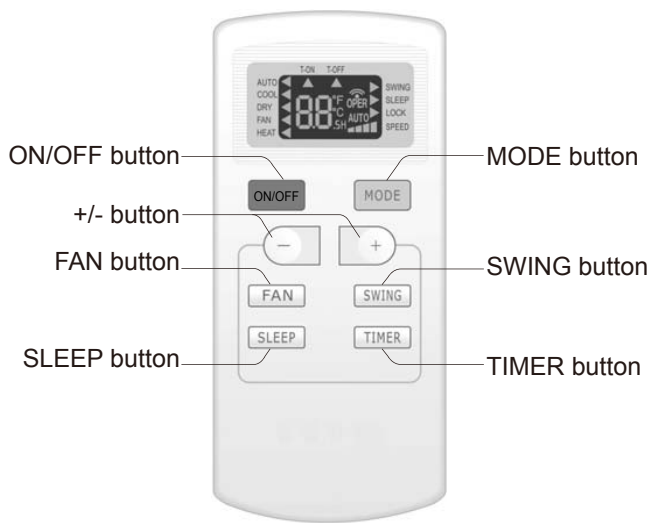
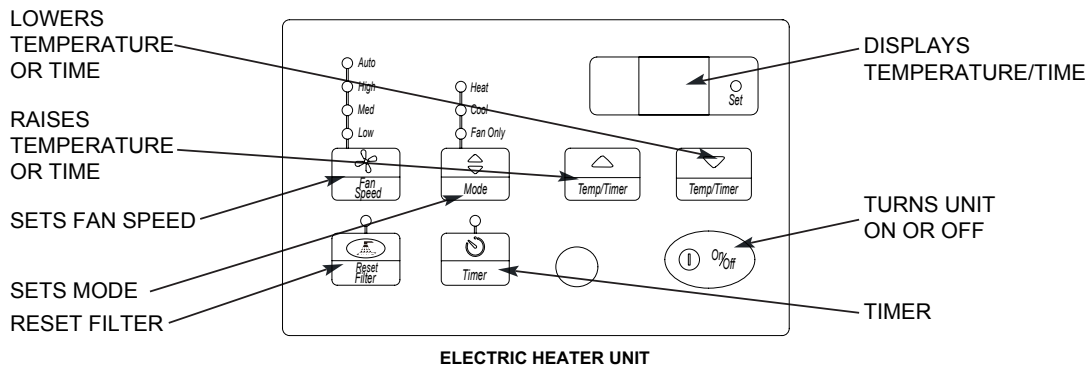
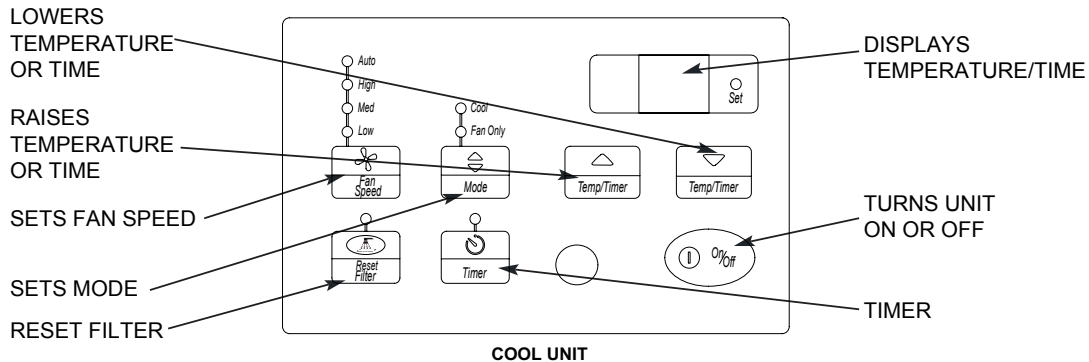

Notice:

- When power is connected (stand by condition), you can operate the air conditioner through the remote controller.
- When unit is on, each time you press the button on remote controller, the sending signal icon "📶" on the display of remote controller will blink once. If the air conditioner gives out a beep sound, it means the signal has been received.
- When unit is off, set temperature will be displayed on the remote controller (If the light of indoor unit display is turned on, the corresponding icon will be displayed). When the unit is on, it will display the icon of the ongoing function.
- This is a general use remote controller, it could be used for the air conditioners with multifunction. For functions your model does not have, press the corresponding button on the remote controller and the unit will keep the original running status.

1 ON/OFF button

Press this button to turn unit on/off.

2 MODE button

Pressing this button once will select your required mode circularly as below (the corresponding icon "◀" will be lit up after the mode is selected):



- When selecting auto mode, air conditioner will operate automatically according to ambient temperature. Set temperature can't be adjusted and won't be displayed either. Press FAN button to adjust fan speed.
- When selecting cool mode, air conditioner will operate under cool mode. Then press + or - button to adjust set temperature. Press FAN button to adjust fan speed.
- When selecting dry mode, air conditioner will operate at low fan speed under dry mode. In dry mode, fan speed can't be adjusted.
- When selecting fan mode, air conditioner will operate in fan mode only. Press the FAN button to adjust fan speed.
- When selecting heat mode, air conditioner will operate under heat mode. Press + or - button to adjust set temperature. Press FAN button to adjust fan speed. (Cooling only unit can't receive heating mode signal. If HEAT mode is set by remote controller, pressing the ON/OFF button cannot turn on the air conditioner.)

Note: The unit can only receive the signal for cool/fan/heat and it has no action when receiving the signal of other modes.

3 + / - button

- Pressing + or - button once will increase or decrease set temperature by 1°F(°C). Hold + or - button for 2s, set temperature on remote controller will change quickly. Release the button after your required set temperature is reached.
- When setting Timer On or Timer Off, press + or - button to adjust the time. (See TIMER Button for setting details)

4 FAN button

Pressing this button can select fan speed circularly as: AUTO, SPEED 1 (▲), SPEED 2 (▲▲), SPEED 3 (▲▲▲), SPEED 4 (▲▲▲▲).



Note:

- Under Auto speed, air conditioner will select proper fan speed automatically according to ambient temperature.
- Fan speed can't be adjusted under Dry mode.
- SPEED 4 is not available for this model.

5 SWING button

Press this button to turn on up&down air swing.

6 SLEEP button

Under Cool, Heat and Dry mode, press this button to turn on Sleep function. Press this button to cancel Sleep function. Under Fan and Auto mode, this function is unavailable.

Note: Sleep and swing functions are not available for this model.

7 TIMER button

- When unit is on, press this button to set Timer Off. T-OFF and H icon will be blinking. Within 5s, press + or - button to adjust the time for Timer Off. Pressing + or - button once will increase or decrease the time by 0.5h. Hold + or - button for 2s, time will change quickly. Release the button after your required set time is reached. Then press TIMER button to confirm it. T-OFF and H icon will stop blinking.
- When unit is off, press this button to set Timer On. T-ON and H icon will be blinking. Within 5s, press + or - button to adjust the time for Timer On. Pressing + or - button once will increase or decrease the time by 0.5h. Hold + or - button for 2s, time will change quickly. Release the button after your required set time is reached. Then press TIMER button to confirm it. T-ON and H icon will stop blinking.
- Cancel Timer On/Off: If Timer function is set up, press TIMER button once to review the remaining time. Within 5s, press TIMER button again to cancel this function.

Note:

- Range of time setting is: 0.5~24h
- The interval between two motions can't exceed 5s, otherwise the remote controller will exit setting status.

Child lock function

Pressing “+” and “-” buttons simultaneously will turn on or turn off child lock function. When child lock function is started up, LOCK indicator on remote controller is ON. If you operate the remote controller, remote controller won't send signal.

Temperature display switchover function

Under ON status, press “-” button and “+” button simultaneously to switch between °C and °F.

Operation guide

1. After putting through the power, press "ON/OFF" button on remote controller to turn on the air conditioner.
2. Press "MODE" button to select your required mode: AUTO, COOL, DRY, FAN, HEAT.
3. Press "+" or "-" button to set your required temperature. (Temperature can't be adjusted under auto mode).
4. Press "FAN" button to set your required fan speed: auto, low, medium and high speed.
5. Press "SWING" button to select fan blowing angle.

Replacement of batteries in remote controller

1. Press the back side of remote controller on the spot marked with "", and then push out the cover of battery box along the arrow direction.
2. Replace two No.7 (AAA 1.5V) dry batteries and make sure the positions of + and - polar are correct.
3. Reinstall the cover of battery box.

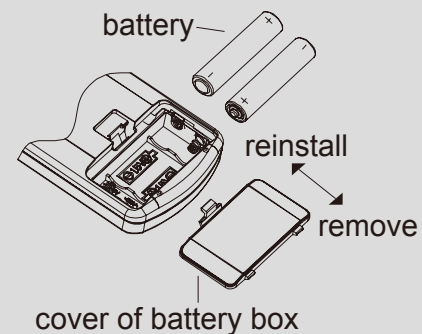

NOTICE

- During operation, point the remote control signal sender at the receiving window on indoor unit.
- The distance between signal sender and receiving window should be no more than 8m, and there should be no obstacles between them.
- Signal may be interfered with easily in rooms where there are fluorescent lamps or wireless telephones; remote controller should be close to indoor unit during operation.
- Replace new batteries of the same model when replacement is required.
- When you don't use remote controller for a long time, please take out the batteries.
- If the display on remote controller is fuzzy or there's no display, please replace batteries.

AUXILIARY CONTROLS-DIP SWITCHES

The auxiliary dip switch controls are located behind the room cabinet - as shown in this figure.

The owner is responsible for checking switches and ensuring they are in the desired position.

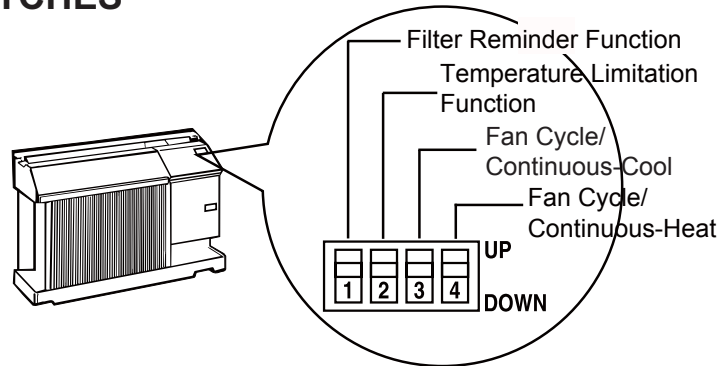

Temperature limitation function

When this switch is disabled (**DOWN**), the running temp range from 61°F to 86°F. When this switch is enabled (**UP**), the running temp range from 65°F to 86°F in cooling and 61°F to 78°F in heating. The default setting is **DOWN** (disabled).

Filter Reminder Function

When this switch is enabled (**DOWN**), an LED will light up the user interface after 250 hrs of accumulated fan run time. It serves as a reminder to clean the filter. When this switch is disabled (**UP**), the function is disabled. The default setting is **DOWN** (enabled).

Fan Cycle/Continuous - Cool

When this switch is enabled (**DOWN**), it allows the indoor fan to cycle on/off with the compressor. When this switch is disabled (**UP**), it allows the indoor fan to run continuously. The default setting is **DOWN** (fan cycle).

Fan Cycle/Continuous - Heat

When this switch is enabled (**DOWN**), it allows the indoor fan to cycle on/off with the heater or the compressor operation. When this switch is disabled (**UP**), it allows the indoor fan to run continuously. The default setting is **DOWN** (fan cycle).

AIR CONDITIONER FEATURES

TO TURN UNIT ON:

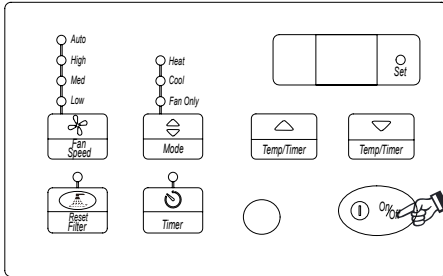

DO THIS:
PRESS ON/OFF
BUTTON

YOU WILL SEE:

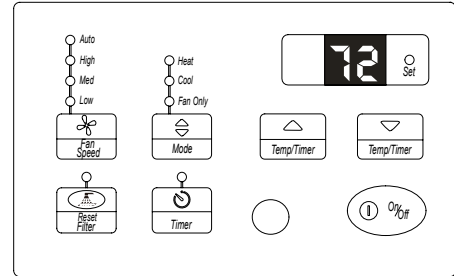

TO CHANGE TEMPERATURE SETTING:

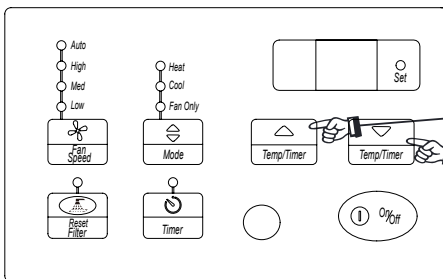

DO THIS:
PRESS TO RAISE
PRESS TO LOWER

YOU WILL SEE:

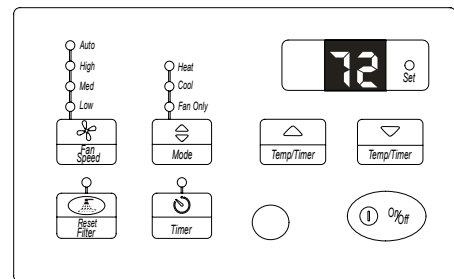

Note: Tap or hold either up(Δ) or down(∇) button until the desired temperature is seen on display. This temperature will be automatically maintained anywhere between 61°F (16°C) and 86°F (30°C) for both cooling and heating modes. If you want the display to read the actual room temperature, "Select the fan only mode".

TO CHANGE FAN SPEEDS:

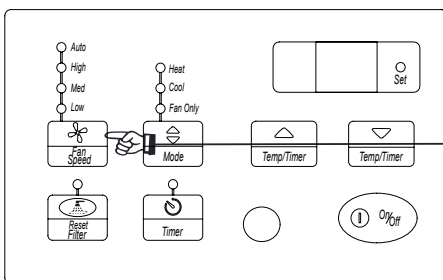

DO THIS:
PRESS FAN SPEED
BUTTON
SELECT SPEED

YOU WILL SEE THE SPEED CHOSEN: LIGHT ON

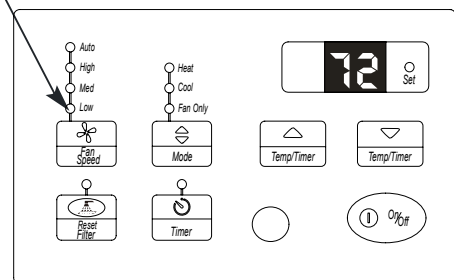

TO USE AUTO FAN FEATURE:

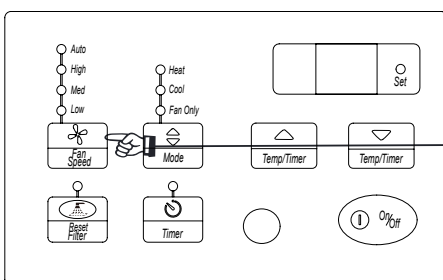

DO THIS:
PRESS FAN
SPEED BUTTON
SELECT
AUTO FAN

YOU WILL SEE: LIGHT ON

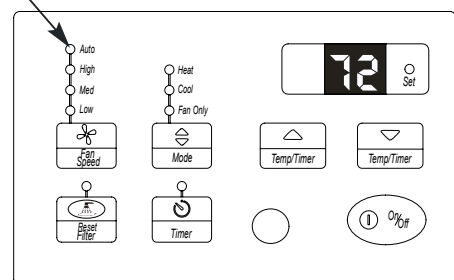

Note: Set fan speed to Auto to provide optimum comfort settings with the set temperature. If the room needs more cooling, the fan speed will automatically increase. If the room needs less cooling, the fan speed will automatically decrease. Auto fan speed cannot be used when in the Fan Only mode.

AIR CONDITIONER FEATURES (continued)

TO OPERATE ON FAN ONLY:

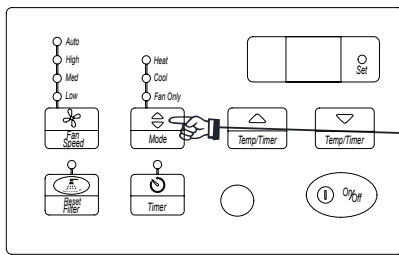

DO THIS:

PRESS
MODE BUTTON

CHOOSE
FAN ONLY

LIGHT ON YOU WILL:

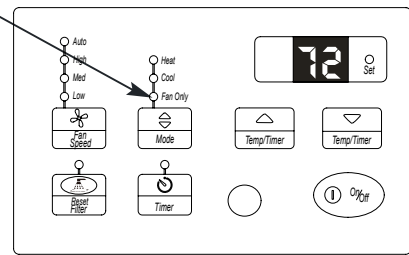

Note: Use this function only when cooling is not desired, such as for room air circulation. You can choose any fan speed you prefer, EXCEPT AUTO FAN. During this function, the display will show the actual current temperature, not the set temperature as in the cooling mode.

TIMER-DELAY START/STOP FEATURE:

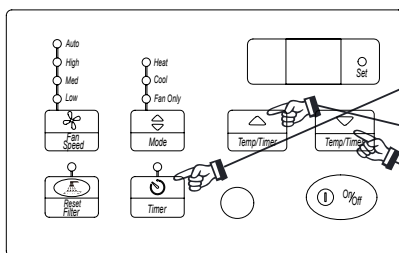

FIRST DO THIS:
PRESS TIMER BUTTON

THEN
DO THIS:
PRESS TEMP/TIMER
BUTTON

YOU WILL SEE THE TIME CHOSEN:

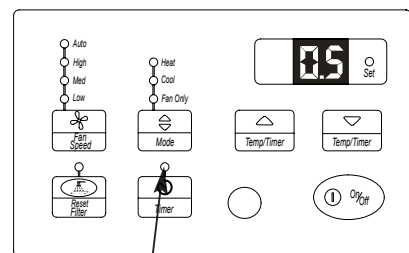

Note 1: For Delay Stop, the unit must be in the ON position.

Note 2: For Delay Start, the unit must be in the OFF position.

To adjust timer setting, tap or hold the UP arrow (^) or DOWN arrow (v) to change the delay time by 0.5 hour increments up to 10 hours, then by 1 hour increments up to 24 hours. The control will count down the timer remaining until start (8, 7.5, 7, etc.). After set Timer, the unit will enter into Timer mode for 5 seconds, then Timer light on, Set light off. In Timer mode: Unit keeps previously set temperature and fan speed; Temperature display set temperature, no display if power turn off; Press Timer once, LED display remaining time of set time, LED returns to set temperature in 5 seconds. When in Fan Only mode, LED only displays room temperature, not display set temperature. Turning the unit "ON" or "OFF" at any time will cancel the Delay Start/Stop function. The delay Start/Stop feature will work until the unit either starts or stops. Once this has happened then the above steps have to be repeated again.

AIR CONDITIONER FEATURES (continued)

COOLING FEATURE:

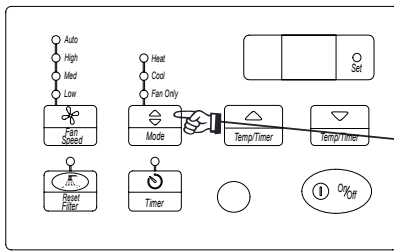

DO THIS:
PRESS
MODE BUTTON
SELECT COOL

YOU WILL SEE:

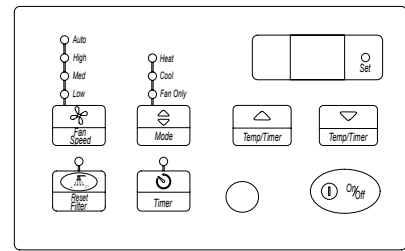

Note: This feature can be used with any combination of FAN Speeds, Timer. When in the “Cool” Mode, the fan will run continuously while cool is needed. The temperature will automatically be maintained anywhere between 61°F (16°C) and 86°F (30°C). When the room set temperature is satisfied, the fan will cycle off and on to circulate and sample the room air. If the air conditioner is off and is then turned on while set to a Cool setting or if turned from a fan setting to a Cool setting, it may take approximately 3 minutes for the compressor to start and cooling to begin.

HEATING FEATURE (on some models):

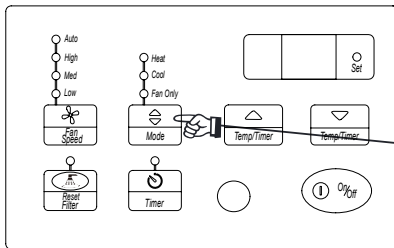

DO THIS:
PRESS
MODE BUTTON
SELECT HEAT

YOU WILL SEE:

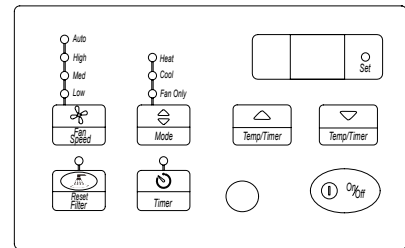

Note: This feature can be used with any combination of FAN Speeds, Timer. When in the “Heat” Mode, the fan will run continuously while heat is needed. The temperature will automatically be maintained anywhere between 61°F (16°C) and 86°F (30°C). When the room set temperature is satisfied, the fan will cycle off and on to circulate and sample the room air.

RESET FILTER FEATURE :

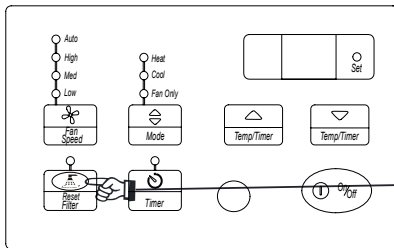

DO THIS:
RESET FILTER

YOU WILL SEE:

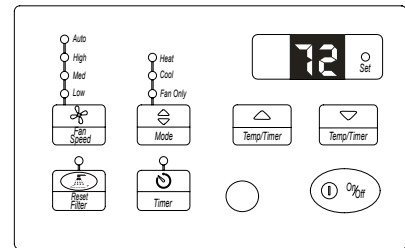

TO TURN UNIT OFF:

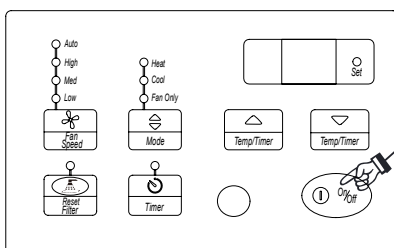

DO THIS:
PRESS
ON/OFF BUTTON

YOU WILL SEE:

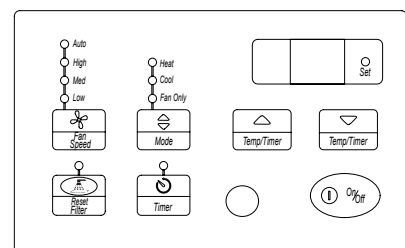

AIR CONDITIONER FEATURES (continued)

FAULT CODES

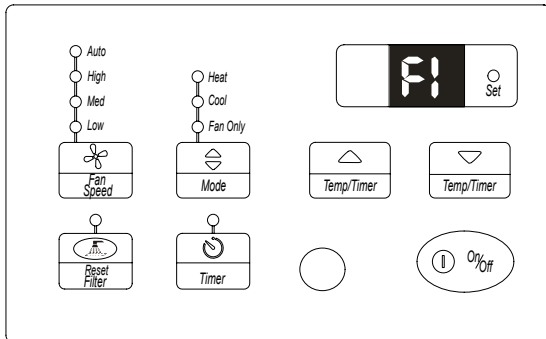

If the display reads “F1”
a sensor has failed.

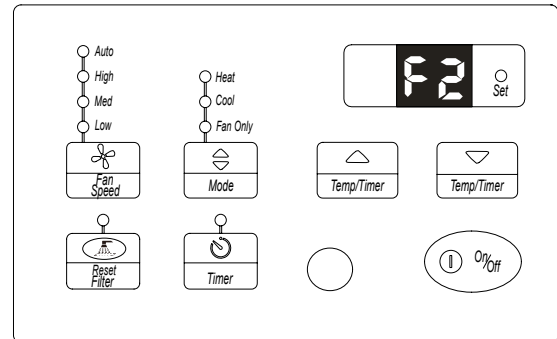

If the display reads “F2”
a sensor has failed.

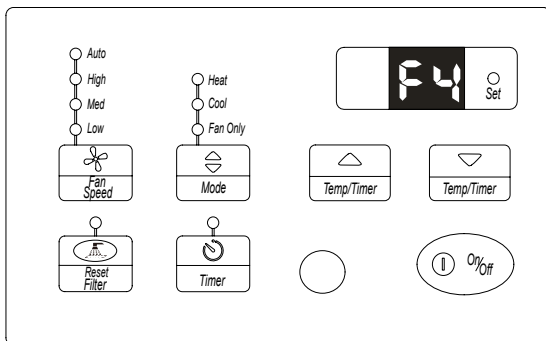

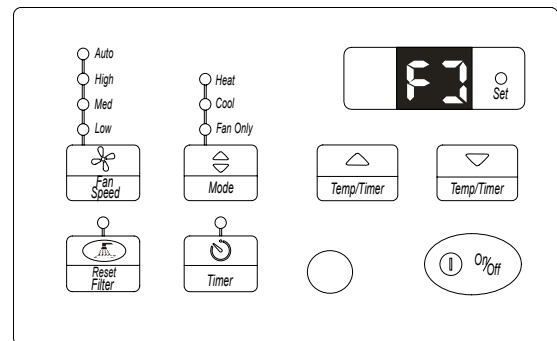

If the display reads “F4”
a sensor has failed.



If the display reads “FJ”
a sensor has failed.

ADDITIONAL THINGS YOU SHOULD KNOW

Now that you have mastered the operating procedure, here are more features in your control that you should know.

- The Remote Control will operate all the control panel features, follow the same instructions.
-  **The "Cool "circuit has an automatic 3 minute time delayed start if the unit is turned off and on quickly. This prevents overheating of the compressor and possible circuit breaker tripping. The fan will continue to run during this time.** 
- The control will maintain any set temperature between 60°F and 90°F degrees (cooling), 55°F and 80°F (heating).
- The control is capable of displaying temperature in degrees Fahrenheit or degrees Celsius. To convert from one to the other, press and hold the Up and Down Temperature Selection Pads at the same time for 3 seconds.
- Instructions for installation and use of this product are provided by the manufacturer.

COMPRESSOR

The compressor is hermetically sealed, permanently lubricated and requires no additional oiling.

FRONT PANEL AND GRILLE

The front panel and grille can be cleaned with a mild soap or detergent. Do not use hydrocarbon-based cleaners (e.g. acetone, benzene, naphtha, gasoline, etc.) to clean the front panel or grille. Use care when cleaning the control area. Do not use an excessively wet cleaning cloth.

SCHEDULED MAINTENANCE

To achieve continuing top performance and high efficiency, a regular cleaning/inspection schedule must be established. Maintaining this schedule can be accomplished by either a local maintenance staff or an authorized servicer and must follow the instructions described in this manual.

- If the unit is operated in a dusty climate, dust may collect in the basepan and clog the condenser coil. It is advisable to remove the unit from the sleeve and thoroughly clean the basepan and condenser coil on a periodic basis.
- If the unit is installed ocean side or in a corrosive atmosphere, its life may be greatly reduced by the corrosive environment. Under these conditions, the unit should be removed from the sleeve and completely cleaned once a year. At that time any scratches or blisters on the painted surfaces should be sanded and repainted.

OUTDOOR COIL CLEANING

The coils on the outdoor side of the air conditioner should be checked regularly. For cleaning outside coil, remove the 6 screws that mount the condenser coil top cover to condenser shroud.



Normal Operating Sounds and Conditions

POPPING OR GURGLING SOUNDS

This sound is the refrigerant traveling through the lines. This is a normal sound which may be heard for a few seconds after the unit shuts off.

WATER TRICKLING SOUNDS

This sound is produced by the water as it is picked up and run over the coils. This procedure improves the efficiency of the unit and helps with water removal.

WATER DRIPPING

Water will collect in the basepan during high humidity days.

STARTING DELAY

You may notice a short delay in the startup if you try to restart the unit too soon after turning it off or if you adjust the thermostat right after the compressor has shut off. This delay protects the compressor.

Obtaining Service

In the unlikely event this unit requires repair or servicing beyond what is covered in this manual, contact an authorized service organization.

To obtain an authorized servicer, contact your sales representative or agency.

LIMITED EXPRESS WARRANTY

Congratulations on purchasing your new HVAC equipment. It's been designed for long life and reliable service, and is backed by one of the strongest warranties in the industry. Your unit automatically qualifies for the warranty coverage listed below, providing you keep your proof of purchase (receipt) for the equipment and meet the warranty conditions.

LIMITED ONE (1) YEAR PARTS AND LABOR EXPRESS WARRANTY

Comfort-Aire/Century warrants all parts of the PTTC, PTTE, or PTTH to be free from defects in workmanship and materials for normal use and main-tenance for one (1) year from the date of purchase by the original con-sumer. Comfort-Aire/Century will also provide a one year labor allowance for approved warranty repairs. Any fees charged by a service technician above and beyond the amount authorized by Comfort-Aire/ Century will be the responsibility of the consumer. No reimbursement will be made for expenses incurred in making field adjustments or replacements unless specifically authorized by Comfort-Aire/Century.

LIMITED FIVE (5) YEAR SEALED SYSTEM WARRANTY

The sealed system consisting of the compressor, evaporator coil, con-denser coil and connecting tubing is warranted to be free from defects in workmanship and materials for normal use and maintenance for four additional years, for a total of five (5) years, from the date of purchase by the original consumer.

LIMITED FIVE (5) YEAR FUNCTIONAL PARTS WARRANTY

Functional parts which consist of the fan motor, unit-mounted thermostats and thermisters, circuit boards, factory installed heaters and relays, unit blower wheel and fan propeller, reversing valve solenoid, and capacitor are warranted to be free from defects in workmanship and materials for normal use and maintenance for four additional years, for a total of five (5) years, from the date of purchase by the original consumer.

The express warranties described above apply only when the unit is installed and operated per Comfort-Aire/Century installation and operation instructions for normal use.

EXCEPTIONS

The Limited Express Warranty does not cover normal maintenance. Comfort-Aire/Century recommends that regular inspection/maintenance be performed at least once a season and proof of maintenance be kept. Additionally, labor charges (except as described in the Limited One Year Warranty paragraph), diagnostic charges, transportation charges for replacement parts, replacement of refrigerant or filters, and any other service calls/repairs are not covered by this Limited Warranty. It also does not cover any portion or component of the system that is not supplied by Comfort-Aire/Century, regardless of the cause of failure of such portion or component.

CONDITIONS FOR WARRANTY COVERAGE

- Unit must be operated according to Comfort-Aire/Century operating instructions included with the unit and cannot have been subjected to accident, alteration, improper repair, neglect or misuse, or an act of God (such as a flood)
- Serial numbers and/or rating plate have not been altered or removed
- Performance cannot be impaired by use of any product not authorized by Comfort-Aire/Century, or by any adjustments or adaptations to components
- Damage has not been a result of inadequate wiring or voltage conditions, use during brown-out conditions, or circuit interruptions
- Air flow around any section of the unit has not been restricted
- Unit remains in the original installation
- Unit was not purchased over the internet

PTT_WARRANTY_11/2017

DURATION OF WARRANTY & REGISTRATION

The warranty begins on the date of purchase by the original consumer. The consumer must retain a receipted bill of sale as proof of warranty period. Without this proof, the express warranty begins on the date of shipment from the factory.

REMEDY PROVIDED BY THE LIMITED EXPRESS WARRANTY

The sole remedy under the Limited Warranty is replacement of the defective part. If replacement parts are required within the period of this warranty, Comfort-Aire/Century replacement parts shall be used; any warranty on the replacement part(s) shall not affect the applicable original unit warranty. Ready access to the unit for service is the owner's responsibility. Labor to diagnose and replace the defective part is not covered by this Limited Express Warranty. If for any reason the replacement part/product is no longer available during the warranty period, Comfort-Aire/Century shall have the right to allow a credit in the amount of the current suggested retail price of the part/product instead of providing repair or replacement.

LIMITATION OF LIABILITY

1. There are no other express or implied warranties. Comfort-Aire/ Century makes no warranty of merchantability. We do not warrant that the unit is suitable for any particular purpose or can be used in buildings or rooms of any particular size or condition except as specifically provided in this document. There are no other warranties, express or implied, which extend beyond the description in this document.
2. All warranties implied by law are limited in duration to the one-term of the parts warranty. Your exclusive remedy is limited to the replacement of defective parts. **We will not be liable for any consequential or incidental damages caused by any defect in this unit.**
3. This warranty gives you specific legal rights and you may also have other rights which vary from state to state. Some states do not allow limitation on how long an implied warranty lasts or do not allow the exclusion or limitation of incidental or consequential damages, so the above limitations or exclusions may not apply to you.
4. No warranties are made for units sold outside the continental United States and Canada. Your distributor or final seller may provide a warranty on units sold outside these areas.
5. Comfort-Aire/Century will not be liable for damages if our performance regarding warranty resolution is delayed by events beyond our control including accident, alteration, abuse, war, government restrictions, strikes, fire, flood, or other acts of God.

HOW TO OBTAIN WARRANTY SERVICE OR PARTS

First contact your installing contractor for service. If the installing contractor is not able to service the unit, contact our North American service provider at 1-866-557-1865. Have the model number, serial number, and date of purchase available for this call.

Owner responsibilities are set forth in the instruction manual—read it carefully.

KEEP THIS INFORMATION AS A RECORD OF YOUR PURCHASE	
PRODUCT IDENTIFICATION	INSTALLATION
Model Number _____	Installer Name _____
Serial Number _____	Phone Number/Contact Information _____
Date of Purchase _____	Date Installation Completed _____
<input type="checkbox"/> Component of new HVAC system	<input type="checkbox"/> Replacement only
Remember to retain your bill of sale as proof of warranty period.	

THIS PAGE INTENTIONALLY LEFT BLANK

Due to ongoing product improvements, specifications and dimensions are subject to change and correction without notice or incurring obligations. Determining the application and suitability for use of any product is the responsibility of the installer. Additionally, the installer is responsible for verifying dimensional data on the actual product prior to beginning any installation preparations.

Incentive and rebate programs have precise requirements as to product performance and certification. All products meet applicable regulations in effect on date of manufacture; however, certifications are not necessarily granted for the life of a product. Therefore, it is the responsibility of the applicant to determine whether a specific model qualifies for these incentive/rebate programs.

Comfort-Cire®  **Century**®

1900 Wellworth Ave., Jackson, MI 49203 • Ph. 517-787-2100 • www.marsdelivers.com

