

30-Inch Charcoal Grill with Offset Smoker

OWNER'S MANUAL

Series No. : 1222-A



Customer Service

📞 1-800-618-6798

FOR YOUR SAFETY!

Use outdoors only! Do not use it inside a building, garage, or any other enclosed space. Read the instructions before assembling and using the appliance. DO NOT use the grill unless it is completely assembled, and all the parts are securely fastened. This grill will become very hot, do not move it during use. Keep away from children and pets.

CONTACT US FIRST!

This grill has been made to high quality standards. If you have any questions that are not addressed in this Owner's Manual, or you need parts, please call our customer service hotline or send an email to service@royalgourmetusa.com. Please keep this Owner's Manual for future reference.

Learn more at:

www.royalgourmetcorp.com



Before Using the Appliance	2
For Your Safety	2-3
Symbols	2
General Safety Instructions	2
Safety Instructions	2-3
Proposition 65 warning	3
Intended Use	3
Assembly	3-10
Preparation	3
Required Tools	3
Unpack Grill	3
Caution	3
Parts Diagram	4
Parts and Hardware List	5
Assembly Instructions	6-10
Before Grilling	11
Types of Charcoal	11
Smoking Wood Chips	11
How to Use	12
Smoking Operation	13
Cleaning and Maintenance	13
Grilling Recipes	14-15
Smoking Recipes	16-17
Disposal	18
Declaration of Conformity	18
Technical Details	18
Warranty and Customer Service	18
Spanish	19-37
French	38-56

Before Using the Appliance

After unpacking and before every use, check whether there is any sign of damage. If there is any damage, please do not use the grill and call customer service at 1-800-618-6798.

This owner's manual follows the standards and regulations applicable in the USA. For other countries, please follow the country-specific directives and laws!



Please read the safety information and this owner's manual before using the grill, to ensure safe and reliable use of this product.

Keep this owner's manual in a safe place and please provide this owner's manual along with the grill if you give it to someone else.

For Your Safety

Symbols

Danger: High risk!



Failure to heed the warning can lead to injuries, with potentially fatal consequences.

Caution: Low risk!



Points to take note of when handling the appliance.

GENERAL SAFETY INSTRUCTIONS

- To be observed during each use.
- Do not use indoors!
- WARNING! Do not use spirit or petrol for lighting or relighting!
- WARNING! This appliance becomes extremely hot during use, do not move it when in use!
- WARNING! Keep children and pets away!

Safety Instructions

Danger: Fire hazard!



Live coals and grill components get extremely hot during use and can start fires.

- It is imperative that you have a fire extinguisher and first-aid kit handy in case of an accident or fire.
- Place the grill on an even, horizontal, secure, heat-resistant, and clean surface.
- Set up the grill at least 3 feet (1 meter) away from highly flammable materials such as awnings, wooden patios, or furniture.
- Do not move the grill during use.
- Ignite the charcoal only at a sheltered location.
- Fill the grill with a max. 4.4 lb. of charcoal for the main chamber, and 3.3 lb. for the smoker.
- Some foods produce flammable fats and juices. Clean the grill regularly preferably after each use.
- Only tip out the ash once the charcoal has completely burned out and cooled down.

Danger: Risk of burning and accidents!



This device is not intended for use by persons (including children) with limited physical, sensory, or mental capacities, or lacking experience, or knowledge.

- Such persons must be informed about the dangers of using the appliance and supervised by a person responsible for their safety.
- Any modifications to the product may lead to a large safety risk and are forbidden. Do not undertake any unauthorized modifications. In case of damage, repair, or other problems with the grill, contact our customer service at 1-800-618-6798, or send an email to service@royalgourmetusa.com
- Keep children and pets away from the appliance. The grill, the charcoal, and the grilled food become hot during use. Any direct contact can result in serious burns.
- Keep sufficient distance from the hot parts, as any direct contact can lead to severe burns.
- Always wear oven mitts or BBQ gloves when grilling.
- Use only long-handled utensils with heat-resistant grips.
- Do not wear any clothing with wide sleeves.
- Use only dry lighters or special fluid lighters.
- Let the grill cool down completely before cleaning and/or placing in storage.

Danger: Risk of explosion!



Flammable liquids that are poured on the embers may cause flash flames or explosions.

- Never use flammable liquids such as petrol or spirit.
- Do not put pieces of charcoal soaked in flammable liquid onto the embers.

Danger: Risk of carbon monoxide poisoning!



When burning charcoal, barbecue briquettes, etc., carbon monoxide is formed. This gas is odorless and can be fatal in closed spaces!

- NEVER burn charcoal inside houses, vehicles, tents or other enclosed space.
- Use the grill OUTDOORS ONLY.

Danger: Health risk!



Do not use any decolorants or thinners to remove stains. These are harmful to health and must not come into contact with food.

Danger: Injury to children!



While playing, children can become caught in the packaging film and choke.

- Do not let children play with the packaging film.
- Make sure that children do not put any small assembly parts into their mouths. They could swallow the parts and choke on them.

Danger: Risk of injury



Both the grill and its components have some sharp edges.

- Be careful when touching the grill and its components as there is risk of accidents and/or injury during assembly and use. Wear protective gloves if necessary.
- Do not set up the grill near entryways or where a lot of people move around.
- Always exercise extreme caution while grilling. If distracted, you can lose control of the appliance.
- Always be attentive and aware of what you are doing. Do not use the grill if you are not focused, tired, or under the influence of drugs, alcohol, or medication. Just one moment of carelessness during use of the product can lead to serious injuries.

Caution: Risk of damage!



During use, the screws may loosen slowly and impair the grill's stability.

- Check that the screws are well-tightened prior to each use. If necessary, tighten all the screws again to ensure the grill is standing securely.

Caution: Risk of damage!



Do not use any strong or grinding solvents or abrasive ZJA pads, as these can damage the surface and leave behind scrape marks.



CALIFORNIA PROPOSITION 65 WARNING

1. Fuels used in wood and charcoal burning appliances and the combustion byproducts of such fuels, can expose you to chemicals including carbon black, wood dust which are known to the State of California to cause cancer, carbon monoxide, which is known to the State of California to cause birth defects or other reproductive harm.
2. This product can expose you to chemicals including nickel, which is known to the State of California to cause cancer.

For more information, go to: www.P65Warnings.ca.gov

Intended Use

Use this grill to heat, cook and grill food.

This grill is intended exclusively for outdoor use and not for use indoors.

Only use the product as described in this owner's manual.

All other uses are considered improper and can lead to material damage or even personal injuries.

The manufacturer accepts no liability for damage caused by improper use.

Assembly

Preparation

Danger: Risk of explosion!



Failure to follow these instructions can lead to problems and risks while using the grill.

- Follow all the assembly instructions listed here.
1. First read the assembly instructions completely.
 2. Allow yourself enough time for assembly and find an even working space of two to three square meters.
 3. Small parts are preassembled.

Required Tools (Not included)

1 x Phillips screwdriver



1 x Wrench



Unpack Grill

Unpack the grill and dispose of all packaging materials. Keep the packaging materials out of the reach of children and dispose of them according to regulations after assembly of the grill. Take the following steps to assemble the grill.

Caution

Caution: Risk of damage!



During use, the screws can loosen slowly and impair the grill's stability.

- Check that the screws are well-tightened prior to each use. If necessary, tighten all the screws again to ensure the grill is standing securely.

Before use, place the grill on an even, sturdy surface outdoors.

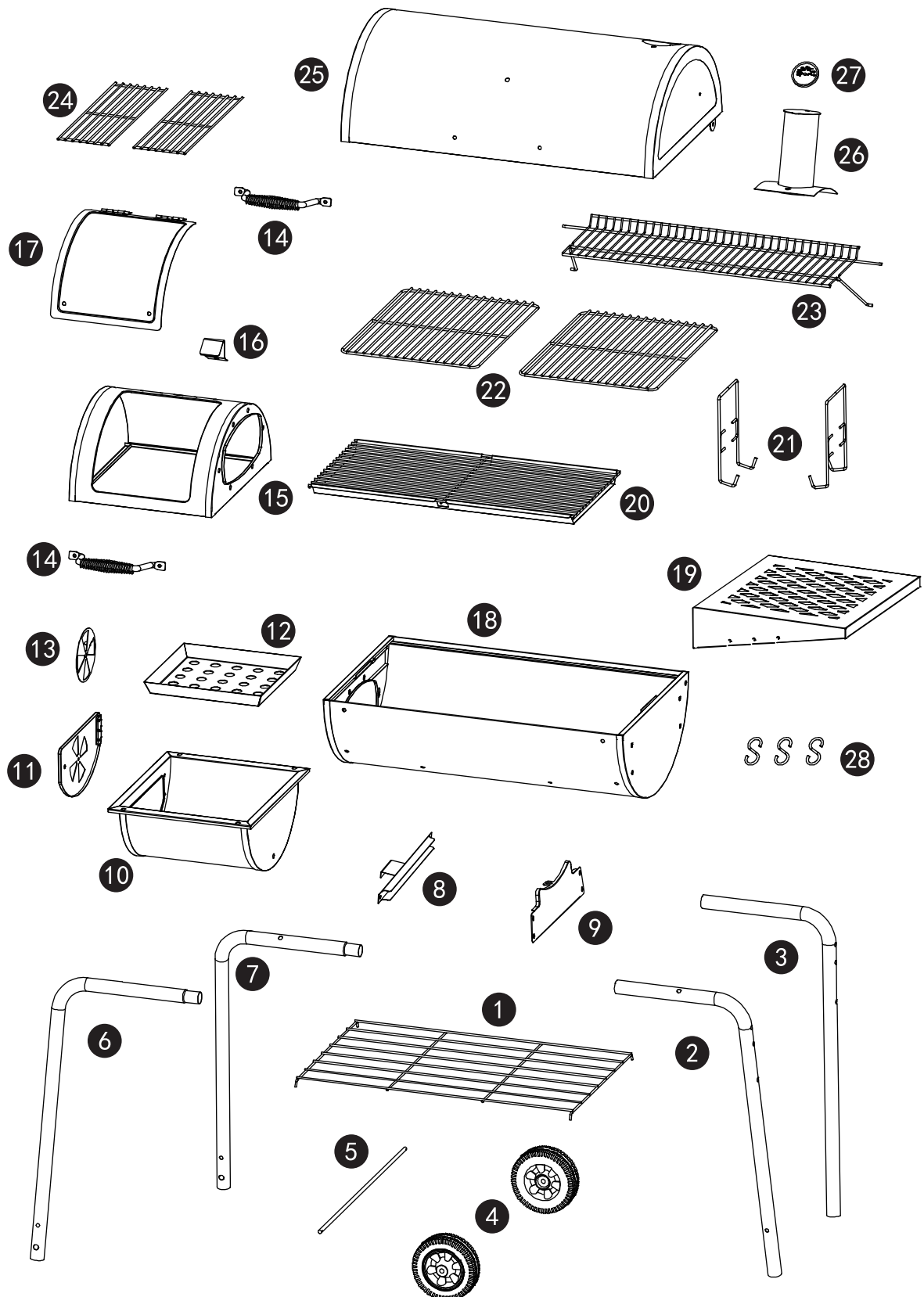

Ref	Description	Illustration	QTY	Ref	Description	Illustration	QTY
1.	Bottom shelf W-CC1830008		1	15.	Smoker chamber top H-CC1830S011		1
2.	Right front leg Z-CC1830S015		1	16.	Smoker lid connector Z-CC1830029		1
3.	Right back leg Z-CC1830S014		1	17.	Smoker lid H-CC1830010		1
4.	Wheel W-20130010		2	18.	Grill chamber H-1830R001		1
5.	Wheel axle W-20130023		1	19.	Side table Z-1830R002		1
6.	Left front leg Z-CC1830S016		1	20.	Charcoal pan set Z-CC1830008 W-CC1830007		1
7.	Left back leg Z-CC1830S017		1	21.	Lifting rack W-CC1826A004		2
8.	Smoker brace H-CC1830003		1	22.	Cooking grate W-CC1830005		2
9.	Leg brace Z-CC1830010		1	23.	Warming rack W-CC1830003+ W-CC1830006		1
10.	Smoker chamber H-CC1830012		1	24.	Smoker cooking grate W-CC1830010		2
11.	Smoker side door H-CC1830007		1	25.	Grill chamber lid H-CC1830001		1
12.	Smoker charcoal pan Z-CC1830054		1	26.	Stack H-CC115WT003 Z-GC33A009		1
13.	Damper Z-GC33E028		1	27.	Thermometer W-11920008		1
14.	Handle W-CC1830S001 W-CC1830002		2	28.	"S" hook W-CC115WT008		3

A	M6x15	30 pcs	B	M4x8	6 pcs	C	M6	9 pcs	D	M6	3 pcs	E	Split pin	4 pcs
F	Pad	2 pcs	G	M5x10	4 pcs									

Step 1

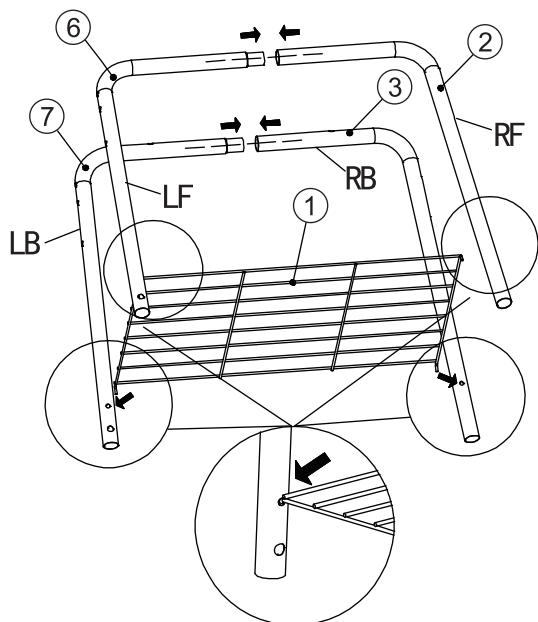

Connect the front legs (2) and (6); connect the back legs (3) and (7).
Assemble the bottom shelf (1) to the legs.

Step 2

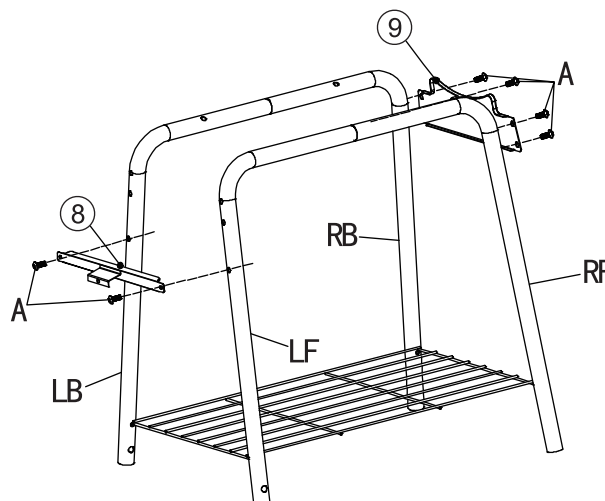

Assemble the smoker brace (8) to the left legs with 2 bolts (A), then attach the leg brace (9) to the right legs with 4 bolts (A).
Please note: Do not secure the bolts until step 4.

Step 3

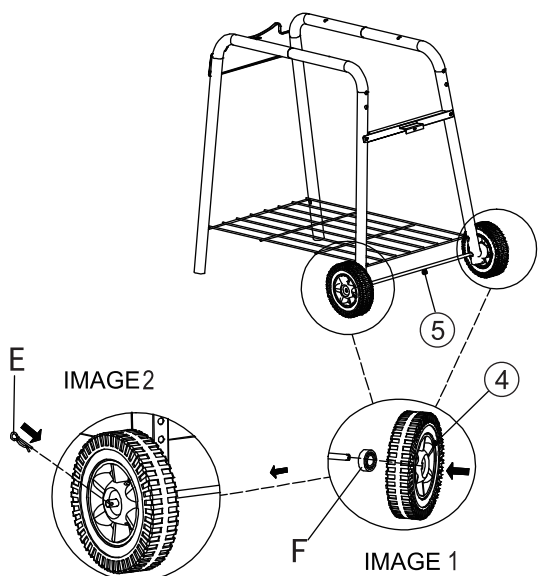

Slide the wheel axle (5) through the lower holes of the left leg assembly.
Attach 2 wheel pads (F) and wheels (4) to the axle from both ends as shown in IMAGE 1.
Secure each wheel with a split pin (E) as shown in IMAGE 2.

Step 4

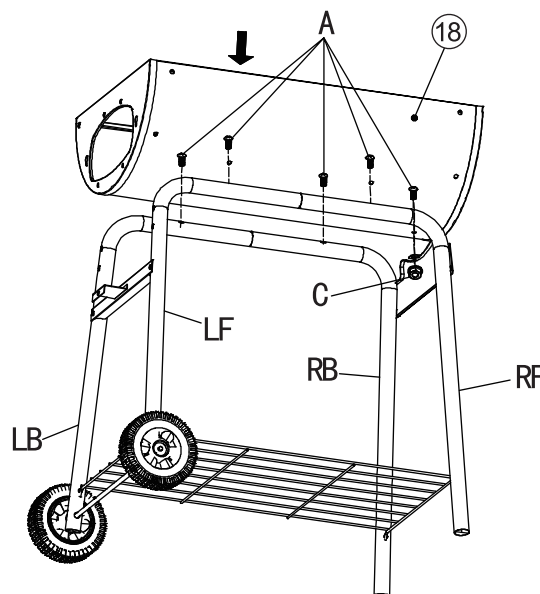

Assemble the grill chamber (18) to the legs with 4 bolts (A).
At this point, hand-tighten the bolts only.
Fasten the grill chamber to the leg connector with 1 bolt (A) and 1 nut (C) as shown.
Now, secure all the bolts.

Step 5

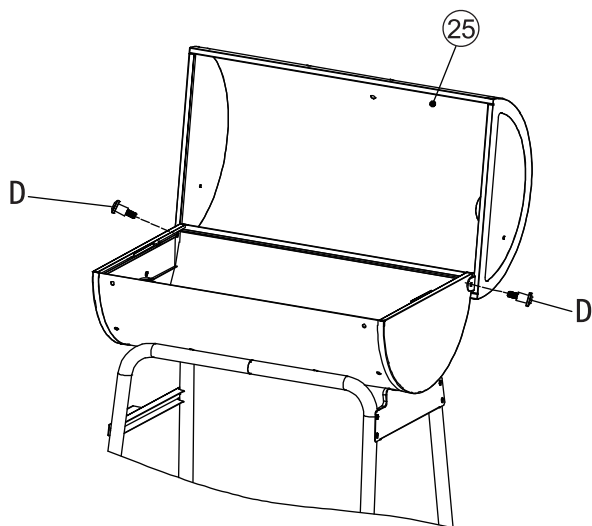

Assemble the grill chamber lid (25) to the grill chamber with 2 bolts (D).

Step 6

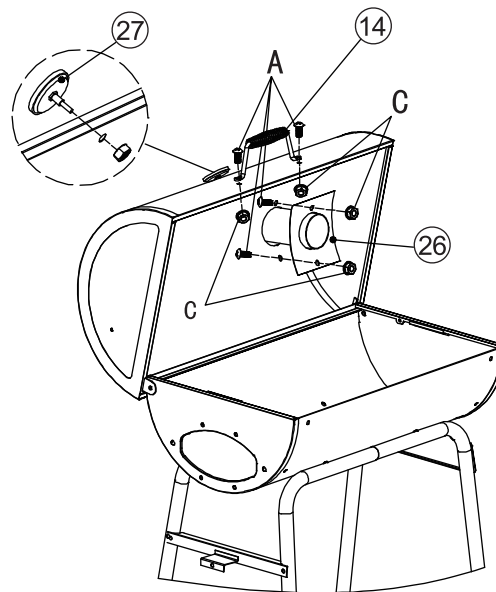

Fasten the handle (14) to the lid with 2 bolts (A) and 2 nuts (C).
Fasten the stack (26) onto the lid with 2 bolts (A) and 2 nuts (C).
Insert the thermometer (27) into the hole on the lid and secure it in place with the nut.

Step 7

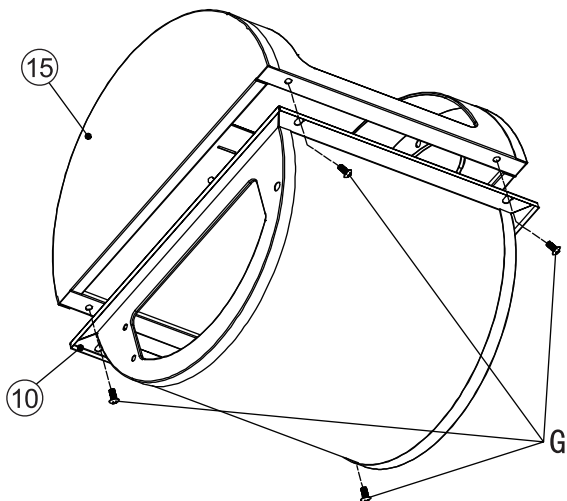

Assemble the smoker chamber (10) and the smoker chamber top (15) together with 4 bolts (G).

Step 8

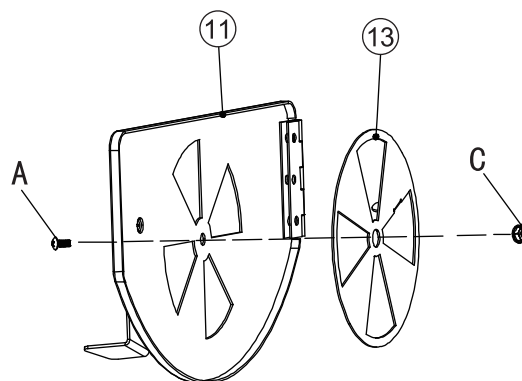

Fasten the damper (13) with the smoker side door (11) with a bolt (A) and a nut (C).

Step 9

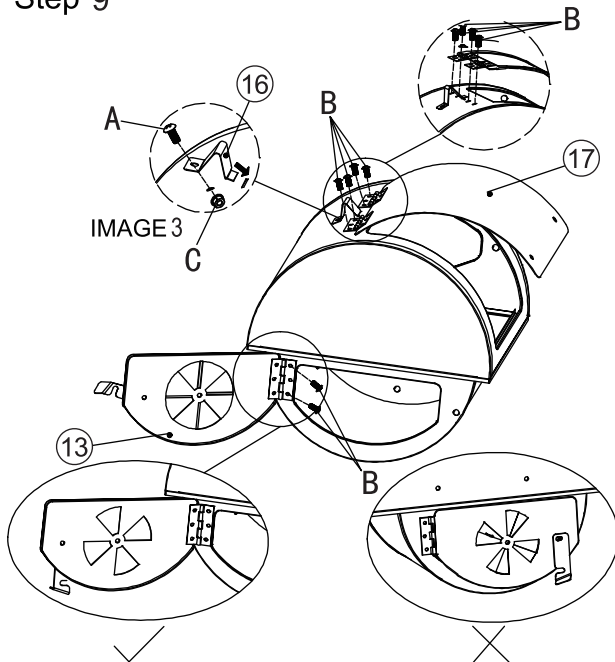

Assemble the smoker side door (13) to the smoker chamber with 2 bolts (B).
 Insert the smoker lid connector (16) to the smoker chamber with 1 bolt (A) and 1 nut (C) as shown in IMAGE 3.
 Assemble the smoker lid (17) to the smoker chamber with 4 bolts (B).

Step 11

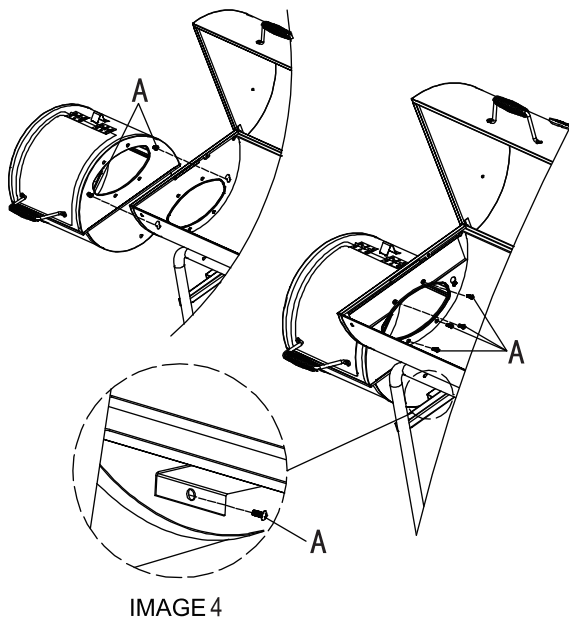

Half screw 2 bolts (A) on the smoker and align them with the holes on the grill chamber as shown.
 Fasten the smoker to the grill chamber with another 4 bolts (A) as shown.
 Secure the smoker to the smoker brace with 1 bolt (A) as shown in IMAGE 4.

Step 10

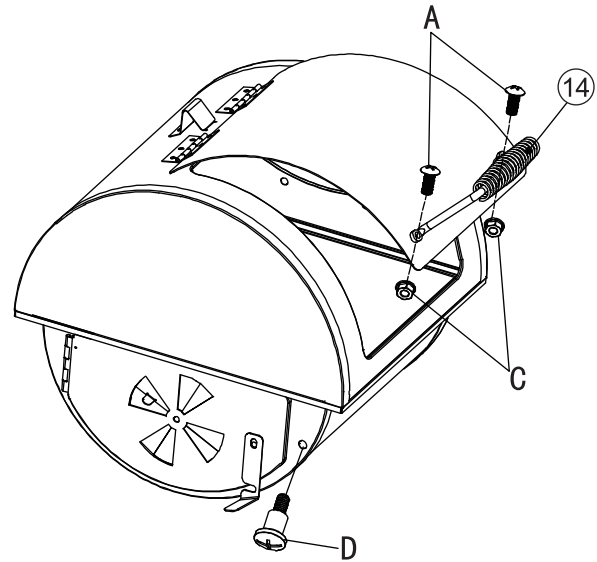

Fasten the handle (14) to the smoker lid with 2 bolts (A) and 2 nuts (C).
 Screw 1 bolt (D) to the smoker chamber as shown.

Step 12

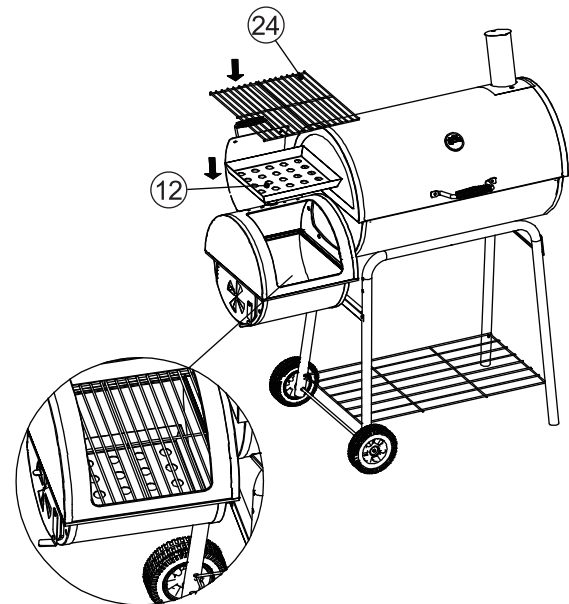

Place the smoker cooking grates (24) and smoker charcoal pan (12) into the smoker.

Step 13

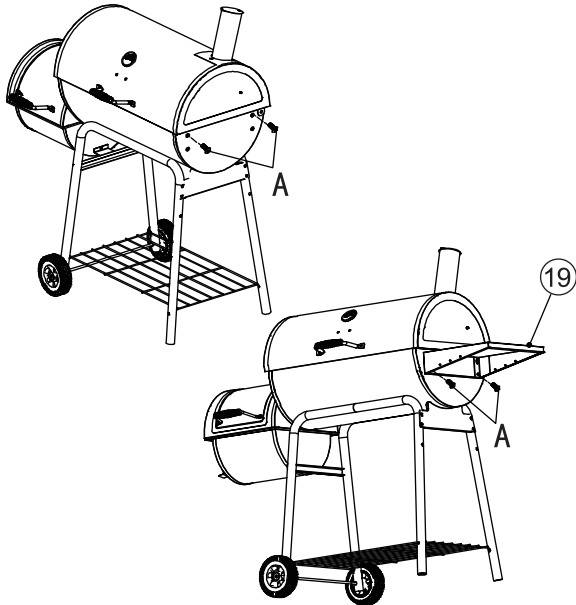

Half screw 2 bolts (A) to the relative holes on the right side of the grill chamber as shown, then hang the side table (19) to the half-screwed bolts. Fasten it with 2 bolts (A) and the the half-screwed bolts.

Step 14

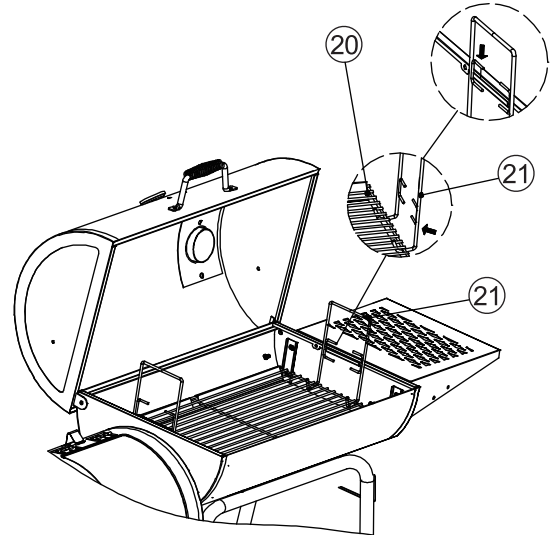

Connect the lifting racks (21) to the charcoal pan (20) and place them into the grill chamber as shown.

Step 15

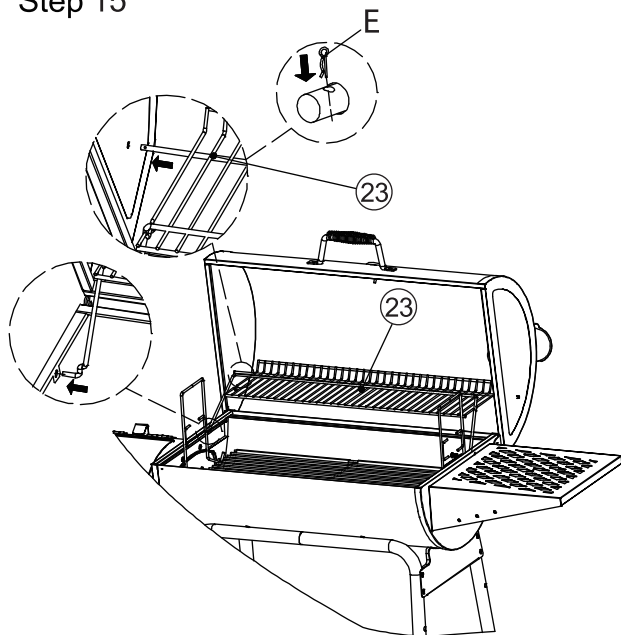

Insert the warming rack (23) by attaching it to the firebox and the lid. Secure it with 2 split pins (E) as shown.

Step 16

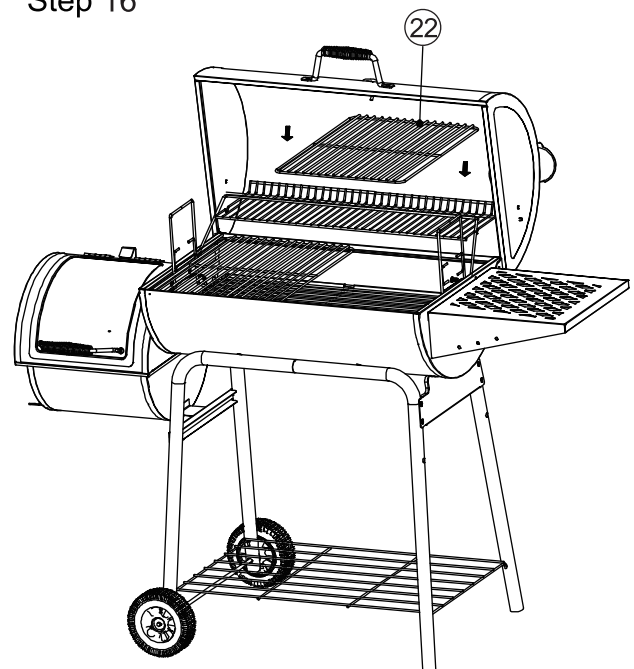

Place the cooking grates (22) into the main body.

Step 17

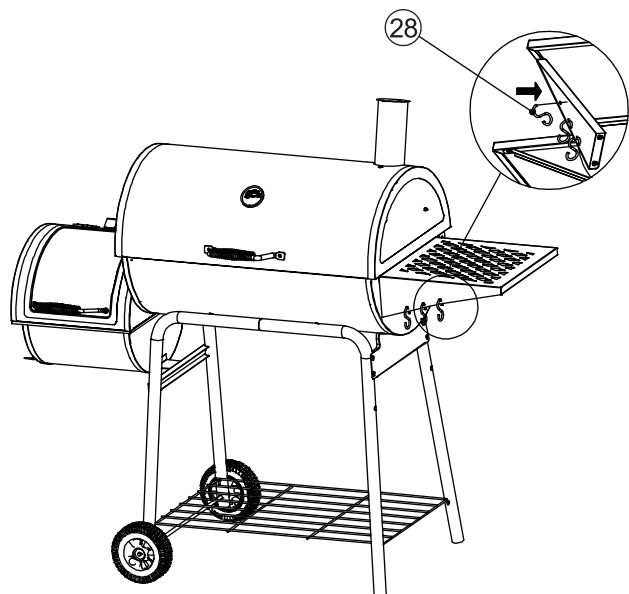

Attach the " S " hooks (28) to the side table.

Before Grilling

• Prior to first use, wash the cooking grates and the warming rack with warm soapy water.

• Pre-firing

Before you use the grill for the first time, it needs to be conditioned (pre-fired) for at least 1–2 hours at a temperature of 212 °F–392 °F. It is necessary to make the inside ready for barbecuing and for burn-in of the the heat-resistant paint on the outside.

Failure to properly follow these steps may damage the paint and/or impact metallic flavors to your first foods. Before pre-firing, brush the interior chamber surface and cooking grates with vegetable oil.

And then build a fire on the charcoal pan.

During pre-firing, close the lid and slide the damper and stack approximately at one quarter open for at least 1-2 hours (the longer the better). Then, you may slide the damper and stack half way and add more charcoal on the charcoal pan to increase the temperature inside.

Caution: The temperature must never exceed 400 °F.

 **The grill may drip oil during cooking process and for several uses afterwards. This is normal.**

NEVER EXCEED 400 °F AS THIS WILL DAMAGE THE FINISH AND CONTRIBUTE TO RUST. PAINT IS NOT UNDER WARRANTY AND WILL REQUIRE OCCASIONAL TOUCH-UP. NEVER PAINT THE INTERIOR OF THE UNIT. THE PRODUCT IS NOT WARRANTED AGAINST RUST.

Types of Charcoal

You can burn either charcoal briquettes or natural lump charcoal, which have different attributes. Charcoal briquettes typically provide longer cooking time and are usually less expensive while lump charcoal burns hotter and produces less ash.

Smoking Wood Chips

Tips for Using Wood Chips

A lot of smoke is produced when using wood chips. Smoke can escape through seams and turn the inside of the smoker black.

This is normal. Wood chips must be used to produce smoke and create the smoke flavor. Never use more than 1 box of wood chips at a time. Never use wood chunks.

You can use dry or pre-soaked wood chips in your smoker.

Dry chips burn faster and produce more intense smoke.

Chips pre-soaked in water (for approximately 30 minutes) burn slower and produce a less intense smoke.

Check wood chip box periodically to see if wood has burned down. Add more chips as required.

Smoking with wood chips/wood chunks

For a more robust smoke flavor while using charcoal briquettes

or lump charcoal, try adding wood chips or several wood

chunks to the fire. Wood chunks are available in a variety of

natural flavors and can be used alone or in addition to charcoal.

As a rule, any hardwood that bears a fruit or nut is suitable for

cooking. However, different woods have different tastes.

Experiment with different woods to determine your personal

favorite, and always use well-seasoned wood. Green or

fresh-cut wood can turn food black and taste bitter.

Our Recommendations:

Chicken – Alder, Apple, Hickory, Mesquite, Sassafras, Grapevine

Beef – Hickory, Mesquite, Oak, Grapevine

Pork – Fruitwoods, Hickory, Oak, Sassafras

Lamb – Fruitwoods, Mesquite

Veal – Fruitwoods, Grapevine

Seafood – Alder, Mesquite, Sassafras, Grapevine

Vegetables – Mesquite

How to Use

Danger: Risk of burning!



The grill, burning charcoal, charcoal, and the BBQ meat can become extremely hot during use. Any direct contact can result in serious burns.

- Keep sufficient distance from hot parts, as any direct contact can lead to severe burns.
- Always wear oven or BBQ gloves when grilling.
- Use only long-handled utensils with heat-resistant grips.
- Do not wear any clothing with wide sleeves.
- Use only dry lighters or special fluid lighters.

Lighting Your Grill:

1. Open the lid and remove the cooking grates.
2. To start a charcoal fire, stack 4.4 lb. charcoal briquettes into a pyramid-shaped pile and saturate with lighter fluid.
 Do not use gasoline, kerosene, or alcohol for lighting charcoal. Use of any of these or similar products can cause an explosion possibly leading to severe bodily injury.
3. Light the briquettes in several places.
4. After the briquettes ash over and produce a red glow, spread them evenly across the charcoal pan. Please use a suitable heat-resistant tool with a long, heat-resistant handle when you do this.
5. Put the cooking grates in place and adjust the charcoal pan to the desired height by using the lifting handle/lever and start cooking.
6. If the charcoal is not burning evenly, please use long-handled tongs to move coals for even heat.
7. Leave the lid open or closed based on the type of BBQ meat. Please close the lid when longer cooking time is needed. The thermometer located on the lid shows the temperature to ensure it is not too high for a particular BBQ meat.



Chimney starters, electric starters, or other types of fire starters may be used instead of lighter fluid to light fire but use only according to manufacturer's instructions.

Never use instant light charcoal or charcoal lighter fluid with any other starting methods.



Allow enough time for grill to heat up before cooking. You can't cook properly when the grill is cold, and you can't build a fire properly when you are busy preparing food.

Once the fire is burning well, it is easy to keep it going with a little attention.



Rising heat will move up and out of the grill, open the dampers to allow more fresh air into the grill.

The more air into the grill, the hotter the internal temperature will be until the fuel has been maximized. During cooking, the dampers can be fully open to ensure a higher internal cooking temperature. Close the dampers as needed to decrease the airflow for a lower cooking temperature. Check the heat indicator to monitor the grill temperature.



The adjustable charcoal pan can also be used to control the temperature.

Use the lifting handles to raise the charcoal pan for quick searing and lower it for slow cooking.

Always use a flame-retardant insulated grill mitt when adjusting the air vent or the charcoal pan.



Use extreme caution when opening the lids or adding charcoal to avoid injury.

1. Use the lifting handles to lower the charcoal pan to its lowest setting.
2. Open the lids and smoker side door by using a pair of flame-retardant insulated grill mitts. (Handles will be extremely hot.) Please take out all food and remove the cooking grates to add charcoal. Make sure to move the cooking grates back into position after adding charcoal.
3. Use flame-retardant insulated grill mitts and long-handled tongs to stoke coals. Make sure the ash fall through the slots in the charcoal pan.
4. Raise or lower the adjustable charcoal pan for desired cooking temperature.



Do not use lighter fluid or instant light charcoal when adding additional charcoal to an existing fire.



This is dangerous and can cause injury. It will also leave a lighter fluid aftertaste on your food. Only add regular charcoal or wood chunks to an existing fire.

Smoking Operation



To light the grill by cooking indirectly or smoking foods at low temperature.

1. Open the lid and remove the cooking grates.
2. To start a charcoal fire, stack 4 lb. of charcoal in a pyramid-shaped pile and saturate with lighter fluid.
 Do not use gasoline, kerosene, or alcohol for lighting charcoal. Use of any of these or similar products could cause an explosion and possibly cause severe bodily injury.
3. Light coals in several places.
4. After the briquettes ash over and produce a red glow, place hot charcoals on the cooking grates in the offset smoker if you have one. Place hot charcoals on the middle of the cooking grates. To do this, use a suitable fireproof tool with a long, heat-resistant handle.
5. Place water/drip pan on the right side of the cooking grates in the offset smoker if have one.
6. Place the cooking grates in low position.
7. Add water-soaked hardwood chips for a smoke flavor.
8. Put the cooking grates in place.
9. Close the lid and control heat with the dampers and side door.

Tips for Smoking BBQ



Pans are not included, and a disposable bread pan is recommended. Please purchase it separately.

- If you want to sear certain foods before smoking, please place meat directly above charcoals on the hot cooking grates with the lid open for several minutes.
- Add flavor-soaked wood chips to the fire and add 1-part marinade, beer, or wine with 3 parts water into the pan.
- Open the smoking chamber will extend cooking time.
- Insert the thermometer into the thickest part of the fowl not touching the bone and allow five minutes to register.
- Meat should be cooked until the internal temperature reaches 140 °F for rare, 160 °F for medium, and 170 °F for well-done or the fowl leg moves easily in the joint.
- Check the water level when cooking for more than 4 hours or when you can't hear the water simmering.
- Turn the meat over and add more water in the pan.

IF THE SMOKE IS WHITE, THE FIRE IS PERFECT.

IF THE SMOKE IS BLACK, YOU NEED MORE AIRFLOW.

Cleaning and Maintenance

Your grill is made of high-quality materials. To clean and maintain the surfaces, please follow the below instructions:

Danger: Risk of burning!



Let the grill cool down completely before cleaning.

- Only tip out the ash when the charcoal has completely burned out.

Danger: Health risk!



Do not use any decolorants or thinners to remove stains. These are harmful to health and must not come into contact with food.

Caution: Risk of damage!



Do not use any strong or grinding solvents or abrasive pads, as they can damage surfaces and leave behind scratch marks.

When you have finished grilling, you can shut down your grill by closing both dampers and allowing the fire to extinguish.

Be patient. This may take an hour or more.

Empty the Ashes & Ash tray:



After the fire is completely extinguished you should wait several hours before emptying the ashes to ensure they are not hot, or else there will be risk of burns.

- Knock any ashes that did not fall into the ash tray from the cooking grates. (If there are pieces of partially burned charcoal on the charcoal pan you can save them for use the next time. They are still good).
- Tap the sides of the chamber to loosen any ash that is on the sides.
- Unclip the ash tray from the bottom of the grill and take it out.
- Give the ash tray a few firm taps to loosen any ash that may be stuck.
- Place the ashes in a metal container and fill with water to ensure there are no lit coals, then you can dispose of the ashes.
- Let the charcoal burn out completely after grilling. This eases the cleaning effort by burning away excess fat and BBQ residue.
- Lift out the charcoal pan and empty out the cold ash. It is particularly important that you remove the ash before moisture combines with the cold ash. Ash collects moisture, which can cause premature rusting and decay from the inside of the ash collecting tray. Thus, over years the ash collecting tray can get rusted and damaged.
- Clean the grill regularly and optimally after every use.
- Remove the cooking grates and clean them thoroughly with soapy water. Then dry them off thoroughly.
- Use a wet sponge to remove loose residue from the grill.
- Use a soft, clean cloth for drying. Do not scratch the surfaces when wipe them dry.
- Clean the internal and external surfaces with warm soapy water.
- Tighten all screws before every use to ensure your grill is stable at all times.
- Protect your grill against weather. Since it is manufactured from steel it will gradually rust. Clean possible rust spots and repair them with fireproof paint. It is important that you remove the ash from the firebox before the cold ash collecting moisture as this can lead to rust damage.



The grill should always be stored where it is protected from moisture.



Charcoal is porous and holds moisture. **DO NOT** leave charcoal in your grill when you are not using it. Charcoal and ashes left inside the ash pan may reduce the life of your grill.

Direct Heat

BEEF INTERNAL TEMPERATURE CHART			
Cooking Degree	Internal Core Temperature	Internal Description	Firmness
Rare	125 °F	Center is bright red, pinkish toward the outer portion, and warm throughout	Soft to the touch
Medium Rare	130-135 °F	Center is very pink, slightly brown toward the outer portion and slightly hot	Yields only slightly to the touch
Medium	140-145 °F	Center is light pink, outer portion is brown and hot throughout	Beginning to firm to the touch
Medium Well	150-155 °F	Mostly brownish gray throughout with a hint of pink in the center	Firm to the touch
Well Done	155 °F and above	Steak is brownish gray throughout	Firm or hard to the touch
POULTRY INTERNAL TEMPERATURE CHART			
Whole Chicken	165 °F	Cook until the juices run clear	Firm to the touch
Dark Meat	165 °F	Cook until white throughout but still moist	Firm to the touch
Breast Meat	165 °F	Cook until white throughout but still moist	Firm to the touch
Thigh, Wings and Legs	165 °F	Mostly brownish gray throughout with a hint of pink in the center	Firm to the touch
PORK INTERNAL TEMPERATURE CHART			
Medium	150 °F	Pink in the center	
Well Done	160 °F and above	Pork is uniformly white/brown throughout	
Pork Ribs	180-200 °F	Pale white. Cook medium to well done	
Raw Sausage	160 °F	No longer pink	
Sausage (Pre-cooked)	140 °F	No longer pink	

STEAK (& ALL MEATS):

- Cook food on the charcoal side of the unit, directly above coals/heat.
- To grill meats, raise the charcoal pan to its highest position (hot) and sear for one minute on each side with the lid open to seal in flavor and juices.
- Then lower the charcoal pan to the medium position with lid closed and cook to desired tastes.
- Control heat with dual dampers and adjustable fire grate.

Tip:

Place grilled meat back in the marinade for several minutes before serving - it will be tastier and juicier.

CAUTION:

Boil extra marinade first to kill bacteria remaining from the raw meat.

MARINATED FLANK STEAK:

- Mix marinade ingredients in a nonmetal dish.
 - Let steak stand in marinade for no less than 4 hours in the refrigerator.
 - Brown each side for 5 minutes, but center should remain rare.
 - Cut steak diagonally across the grain into thin slices before serving.
 - Grill with fire grate in high(hot) position with lid open or closed.
-

Meat Marinade

- 1/2 cup vegetable or olive oil
 - 1/3 cup soy sauce
 - 1/4 cup red wine vinegar
 - 2 tbsps lemon juice
 - 1 tsp dry mustard
 - 1 minced clove garlic
 - 1 small minced onion
 - 1/4 tsp pepper
-

QUAIL OR DOVES:

- Cover the birds with good amount of seasoning and marinate overnight.
 - Pour remaining dressing and cover with Texas Pete Hot Sauce for 6 hours.
 - Wrap birds in thick bacon secured by a toothpick.
 - Place on grill. Keep turning until bacon is black.
 - Grill for 20 minutes. Sear with lid open and fire grate in high (hot) position for 1 minute on each side before lowering the grate and closing the lid.
 - To smoke the birds, place them in the center of the grates with fire in both ends of the fire box.
-

HOT DOGS :

- Grill with lid up and cooking grates in high (hot) position for approximately 6 minutes.
 - Turn every few minutes.
-

SWEET CORN IN HUSKS:

- Trim excess silk from end and soak in cold salted water 1 hour before grilling.
 - Grill for 25 minutes – turning several times.
-

KABOBS:

- Alternate any combination of meat, onions, tomatoes, green peppers, mushrooms, zucchini, circular slice of corn-on-the-cob, or pineapple on skewers. Meat could consist of shrimp, scallops, lobster, chicken, sausage, pork, beef, etc.
 - Marinate the meat in refrigerator for several hours.
 - Grill each side for approximately 7 minutes, turning occasionally while basting with marinade.
 - Leave a small amount of room between pieces in order to cook faster.
 - Grill with lid up and the cooking grates in the lowest position.
-

Kabob Marinade:

- 1 cup soy sauce
 - 1/2 cup brown sugar
 - 1/2 cup vinegar
 - 1/2 cup pineapple juice
 - 2 tsp salt
 - 1/2 tsp garlic powder
 - Mix all ingredients in a saucepan and bring to boil.
 - Allow marinade to cool before marinating your meat in it.
 - Marinate beef in the mixture a minimum of 4 hours.
-

HAMBURGERS:

See meat marinade on prior pages.

- You may also marinate by allowing to stand in marinade for 1 or 2 hours at room temperature before cooking or let it stand in a covered dish in the refrigerator for up to 24 hours.
 - Bring to room temperature before cooking.
 - Mix in chopped onions, green peppers, salt, sear 3/4 inch patties on each side, with cooking grates in high position for a few minutes.
 - Lower fire grate to medium position and grill with lid down to avoid flare-ups.
 - Cook each side 3 to 7 minutes according to desired degree.
 - Cook ground meat to 150 °F internal temperature or until juice runs clear (free of blood) to prevent E-coli infections.
 - Burgers can be basted with marinade when turning and/or other ingredients can be mixed in with the ground beef such as chili sauce or powder.
-

SHRIMP (Peeled) & CRAYFISH:

- Place on skewers.
 - Coat with melted butter and garlic salt.
 - Grill for 4 minutes on each side or until pink. Cocktail sauce optional.
-

BAKED POTATOES:

- Rub with butter and wrap in foil and cook on grill with lid down for 50 minutes.
 - Turn after 25 minutes (no need to turn if smoked).
 - Squeeze to check if it is cooked.
-

Indirect Heat

Smoking Time

Food	Weight			Temperature in meat thermometer
Beef Roasts, Beef Brisket	3–4 lb.	1–1½ hours	4–5 hours	140 °F rare
Lamb Roasts, Venison	5–7 lb.	1¾–2½ hours	5–6 hours	160 °F medium
Large cuts of Game	7–9 lb.	2½–3½ hours	7–10 hours	170 °F well done
Pork Roasts	3–4 lb.	1¾–2½ hours	5–6 hours	170 °F
	5–8 lb.	2½–3 hours	7–8 hours	170 °F
Pork/Beef Ribs	Full grill	1½–2 hours	4–6 hours	Meat pulls from bone
Pork Chops	Full grill	¾–1¼ hour	4–6 hours	Meat pulls from bone
Sausage Links	Full grill	2–2¾ hours	4–5 hours	170 °F for fresh sausage
Ham, Fresh	10 lb.	3–4 hours	7–8 hours	170 °F
Ham, Cooked	All sizes	1½–2 hours	3–4 hours	130 °F
Chicken (Cut up or split)	1–4 fryers, cut-up or split	1–1¼ hours	4–5 hours	180 °F/leg moves easily in joint
Chicken (Whole)	1–4 fryers	1¼–1½ hour	5–6 hours	180 °F/leg moves easily in joint
Turkey (Unstuffed)	8–12 lb.	1¾–2½ hours	7–8 hours	180 °F/leg moves easily in joint
Fish, small whole	Full grill	½–¾ hours	2–3 hours	Flakes with fork
Fish, filets, steak	Full grill	¼–½ hours	1–3 hours	Flakes with fork
Duck	3–5 lb.	1–1¾ < hours	5–6 hours	180 °F/leg moves easily in joint
Small game birds	Full grill	¾–1 hour	4–5 hours	180 °F/leg moves easily in joint

SMOKED TURKEY:

- Empty cavity, rinse and pat dry with paper towel.
- Tuck wing tips under the back and tie the legs together.
- Place in center of cooking grate directly above the foil drip pan of water.
- Smoke for 12 minutes per pound. Allow several extra minutes per pound if stuffed, to allow for expansion.
- Use a meat thermometer for best results (190 °F internal).

SMOKED BAKED HAM:

You can smoke fully cooked canned ham or smoked and cured whole ham or shank or butt portion.

Glaze

1 cup of light brown sugar, firmly packed

½ cup orange juice

½ cup honey

- Mix sugar, juice, and honey. Let the glaze sit for at least 4 hours.
- Place fire grate in the lowest position and a drip pan under the meat.
- Remove rind and score fat diagonally to create a diamond pattern.
- Insert a whole clove into the center of every diamond.
- Place ham with fat side up in the center of the cooking grid directly above drip pan. Close lid.
- Cooking for about 9 minutes per pound is suggested for fully cooked ham. Smoked or cured ham, which is not fully cooked, should be cooked to an internal temperature of 160 °F.
- Baste with ham glaze 3 or 4 times during last 30 minutes of cooking time.
- Garnish with pineapple rings for about 15 minutes before end of cooking time.

STUFFED SMOKED HOT DOGS:

- Slit hot dogs lengthwise, within ¼ inch of each end.
- Stuff hot dogs with cheese and relish and wrap in bacon.
- Place on cooking grid over drip pan and smoke for 15–20 minutes or until bacon is crisp.

SMOKED PIECES:

- Rinse pieces in cold water and pat dry with paper towels.
- Brush each piece with vegetable oil and season with salt and pepper to taste.
- Brown pieces directly above coals with lid open and grate in high or medium position for several minutes.
- Then, place pieces on cooking grate directly above drip pan.
- With the grate in the low position, cook with lid down for 55 to 60 minutes or until done. Do not use vegetable oil or salt and pepper if using marinade.

SMOKED VENISON:

Venison Marinade:

- 1 cup balsamic or wine vinegar
- 1 cup olive oil
- 2 oz. Worcestershire
- 1/2 oz. Tabasco
- 2 tbsp. Season-All
- 1–2 chopped jalapenos
- 3 oz. soy sauce

Bacon Marinade

- 2 oz. wine vinegar
- 2 oz. Worcestershire
- 4 dashes tabasco sauce

- Place leg of venison in a container or “hefty bag” and marinate for 2–4 days, turning daily. Marinate bacon overnight in its marinade.
 - Remove roast from refrigerator at least an hour before cooking.
 - Season generously with seasoned salt and coarse ground black pepper.
 - Wrap 1 lb. bacon over the top of the roast, and smoke 20/25 minutes per pound, or until tender. Do not overcook.
-

SMOKED SHRIMP & CRAYFISH:

- Mix 1/2 cup butter, two cloves of crushed garlic, tabasco sauce, sliced green pepper, 1 tablespoon each of minced onions, salt, and juice from one lemon in a foil pan.
 - Add shrimp and/ or crayfish and smoke for 45 minutes.
-

SMOKED VEGETABLES:

- Turnips, potatoes, carrots, okra, mushrooms, peeled onions, zucchini, squash, etc.
 - Put in pan and cover with water and cook for several hours while cooking the meat, or place vegetables on grill and smoke for 50 minutes directly or wrapped in foil.
-

SMOKED FISH:

- Marinate in brine (1/4 cup dissolved in 1 qt. of water) or marinate fish in 1 cup white wine, 1 cup soy sauce mixed with 1 cup lemon juice.
 - Marinate overnight in covered dish in refrigerator.
 - Let it air on rack 20 minutes before placing on Pam-sprayed grill.
 - Smoke for 25 minutes.
-

SMOKED SPARE/BACK RIBS:

- Peel off tough layer of skin on back side.
- Rub all surfaces with seasoning.
- Place ribs in the center of the cooking grid above the drip pan and smoke approximately 1½ hours or until meat pulls away from bone.
- Baste with barbecue sauce during last 30 minutes.

CHICKEN MARINADE:

Mix

- 1/2 cup soy sauce
- 1/4 cup vegetable oil
- 1/4 cup red wine vinegar
- 1 teaspoon oregano
- 1/2 teaspoon sweet basil
- 1/2 teaspoon garlic powder with parsley
- 1/4 teaspoon pepper

- Pour over chicken pieces in a non-metal dish.
 - Cover and refrigerate overnight, turning occasionally. Use marinade to baste chicken while cooking.
-

MEAT MARINADE: (For steaks, chops, and burgers)

Mix

- ¼ cup soy sauce
 - 2 coarsely chopped large onions
 - 2 cloves garlic (halved)
 - Mix ingredients in an electric blender, cover, and process at high speed 1 minute or until mixture is smooth.
 - Stir in 1/4 cup bottle gravy coloring (Kitchen Bouquet and Gravy Master) and 2 teaspoons Beau Monde seasoning (or substitute 1 teaspoon MSG and 1 teaspoon seasoned salt).
 - Allow meat to stand in marinade at room temperature for 2 hours or refrigerate up to 24 hours in a covered dish.
 - Bring meat to room temperature before cooking.
-

SHISH KABOB MARINADE:

Mix

- 1 cup soy sauce
- 1/2 cup brown sugar
- 1/2 cup vinegar
- 1/2 cup pineapple juice
- 2 teaspoon salt
- 1/2 teaspoon garlic powder
- Mix ingredients and bring to a boil.
- Marinate beef in mixture a minimum of 4 hours.

Disposal



The packaging is made from environmentally friendly materials, which you can dispose of at your local recycling points.



Do not dispose of the grill in normal household waste under any circumstance! Dispose it at an approved disposal site or at your community disposal facility

Respect the current valid regulations. If in doubt, get in touch with your disposal facility.

Declaration of Conformity

This product is in compliance with the applicable America and national directives.

Technical Details

Model:	Royal Gourmet® CC1830R
Net Weight:	47.4 lb.
Overall Dimensions (Grill Assembled):	53.7 x 21.6 x 48.8 inches (L x W x H)
Cooking Area:	811 square inches
Max. Amount of Fuel:	4.4 lb. charcoal for main chamber 3.3 lb. charcoal for offset smoker
Steel Paint:	Heat-resistant up to 400°F

Warranty and Customer Service

Thanks for purchasing this Royal Gourmet® Charcoal Grill. We are here to help you maximize your enjoyment and appreciation of your new grill. We provide a warranty for your product within the framework warranty condition under normal use of one year from the date purchase for all components covering defects and manufacturing errors.

Royal Gourmet's obligations are limited to the following:

- This warranty does not cover grills that have been altered or damaged due to normal wear, rust, abuse, improper maintenance, improper use, or modifications, to the product. Repair labor is not covered.
- This warranty does not cover surface scratches or heat damage to the finish which is considered as normal wear.
- All warranty claims apply only to the original purchaser and require a proof of purchase verifying date of purchase.
- All parts that meet the warranty requirements will be shipped at no-charge via the discretion of the customer service department.
- Do not return parts without prior to obtain return authorization from our customer service department.

Except as stated above, Royal Gourmet Corp. makes no other express warranty.

This warranty may give you specific legal rights that vary by state.

Please do not hesitate to contact our customer service when you have any questions regarding assembly, warranty, or accessories. We will be happy to offer any replacement parts you need during the time of warranty period.



1-800-618-6798



service@royalgourmetusa.com



Mon-Fri, 8:30 AM-5:30 PM, EST