

This Owner's Manual is provided and hosted by [Appliance Factory Parts](#).



Royal Gourmet PD1303A Owner's Manual

[Shop genuine replacement parts for Royal Gourmet PD1303A](#)



[Find Your Royal Gourmet Grill Parts - Select From 56 Models](#)

----- Manual continues below -----

3-Burner Portable Gas Griddle

OWNER'S MANUAL

Series No. : 1224-C



Customer Service

☎ 1-800-618-6798

FOR YOUR SAFETY!

Use outdoors only! Do not use it inside a building, garage, or any other enclosed space. Read the instructions before assembling and using the appliance. DO NOT use the griddle unless it is completely assembled, and all the parts are securely fastened. This griddle will become very hot, do not move it during use. Keep away from children and pets.

CONTACT US FIRST!

This griddle has been made to high quality standards. If you have any questions that are not addressed in this Owner's Manual, or you need parts, please call our customer service hotline or send an email to service@royalgourmetusa.com. Please keep this Owner's Manual for future reference.

Learn more at:

www.royalgourmetcorp.com

For Your Safety	2-3
Preparation	4
Parts and Hardware List	5
Assembly Instructions	6
Operating Instructions	7-8
Cleaning and Maintenance	9-10
Troubleshooting Guide	11
Grilling Recipes	12-13
Warranty and Customer Service	14
Spanish	15-29
French	30-44

WARNING

Read the following instructions carefully and be sure your griddle is properly installed, assembled and cared for. Failure to follow these instructions could result in fire or explosion, which could cause property damage, personal injury, or death.

1. DO NOT store or use gasoline, or any flammable vapors and liquids within 8 meters (26 feet) of the griddle.
2. When cooking with oil/grease, do not allow the oil/grease to exceed 177 °C (350 °F). DO NOT store extra cooking oil in the vicinity of the griddle.
3. The liquid LP (propane) tank (cylinder) not connected for use should be stored a minimum distance of 3 meters (10 feet) from griddle or any appliance.
Never fill the LP tank beyond 80 percent full. If the above instructions are not followed exactly, there would be a risk of fire that may cause serious injury or death.

In case of any issue, call us first! DO NOT return the griddle to the retailer. This griddle has been made to high quality standards. If you have any questions not addressed in this owner's manual, or you need parts, please call our customer service hotline.

NOTE: The assembly and use of this griddle must conform to local codes. In the absence of local codes, use the National Gas and Propane Instruction Code. Read all instructions prior to assembly and use.

CAUTION:

1. A 1 lb. (454g) propane gas tank (not included) is required for operation.
2. Never attempt to attach this griddle to the self-contained propane system of a camper trailer, motor home, or house.
3. Never use charcoal or lighter fluid with gas griddles.
4. DO NOT attempt to move the griddle while it is lit or hot.
5. DO NOT use the griddle unless it is completely assembled, and all parts are securely fastened and tightened.
6. DO NOT use the griddle or any gas products near unprotected combustible buildings and materials.
7. DO NOT use in the presence of gases or vapors. Keep the griddle area clear and free from combustible materials, gasoline, and other flammable vapors and liquids.
8. DO NOT lean over the griddle or touch metal parts of the griddle until it has completely cooled (about 45 minutes) to avoid burns, unless you are wearing protective gear (oven mitts, potholders, and etc.).
9. DO NOT alter the griddle in any manner.
10. Keep all combustible items and surfaces at least 91 cm (36 inches) from the griddle at all times.
11. Never keep a filled LP tank in a hot car or truck. Heat will cause the gas pressure to increase, which may open the relief valve and allow the gas to escape.
12. Keep the griddle's valve compartment, burners, and circulating air passages clean. Inspect the griddle before each use.
13. Please ensure you only use your griddle at the correct pressure the appliance is designed for. Prior to installation, ensure that the local distribution conditions (nature of the gas and gas pressure) and the adjustment of the appliance are compatible.
14. Adequate ventilation is vital for combustion and efficiency performance of the griddle. This will ensure the safety of the user and other people in the vicinity of the area where the appliance is being used. Never use the appliance in any enclosed covered area.
15. The parts sealed by the manufacturer or his agent shall not be manipulated by the user.
16. Any modification to the appliance may be dangerous and may cause injury or property damage. Any unauthorized modification of the appliance will invalidate the guarantee on this appliance.
17. Turn off the appliance at the LP tank valve or regulator after use.

WARNING:

1. This griddle is for outdoor use only and should not be used inside a building, garage, or any other enclosed space.
2. The consumption of alcohol, prescription, or non-prescription drugs may impair the operators' ability to properly assemble or safely operate the griddle.
3. Always place your griddle on a hard and level surface far away from combustibles.
4. Do not leave a lit griddle unattended. Accessible parts may be very hot. Children should never use your griddle. ALWAYS keep children and pets away from the griddle.
5. Do not place the griddle on any type of uneven tabletop surface.
6. Do not use the griddle in high winds. When the wind speed is above 2m/s, don't use gas griddle facing to the wind.
7. The use of this appliance in enclosed areas can be dangerous and is PROHIBITED.

DANGER:

Liquid propane gas is flammable and hazardous if handled improperly. Understand the characteristics before using any propane product.

1. Propane characteristics: Flammable, explosive under pressure, heavier than air, settles in pools and low areas.
2. In its natural state, propane has no odor. For your safety, an odorant has been added.
3. Contact with propane can cause freeze burns to the skin.
4. This griddle is shipped from the factory for use with propane gas only.
5. Never use a LP tank with a damaged body, valve, collar, or footing.
6. Dented or rusted propane cylinders may be hazardous and should be checked by your propane gas supplier.

FOR YOUR SAFETY

1. Keep the griddle at least 91cm (36 inches) away from side and back, and 61cm (24 inches) from floor to combustible and noncombustible materials and construction.
2. Do not place the griddle where there are combustible surfaces overhead.

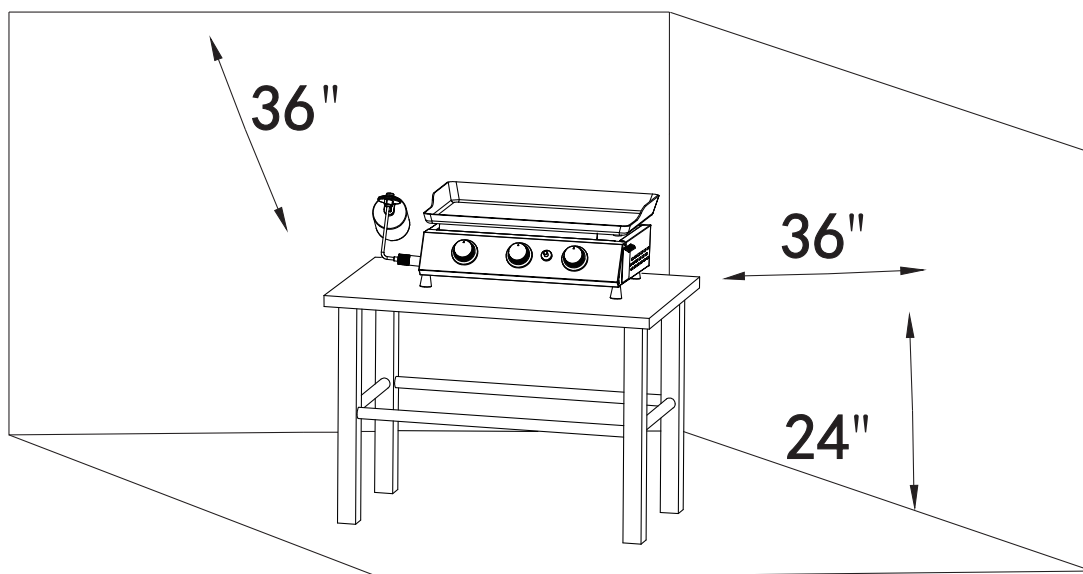

Before beginning assembly, make sure all parts are present. Compare parts with packaged contents list and diagram above. If any parts are missing or damaged, do not attempt to assemble the products. Contact customer service for replacement parts via telephone or email.

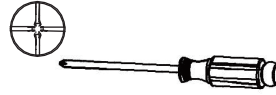

Phillips screwdriver



Wrench

- Estimated assembly time: 10 minutes
- Tools required for assembly:
Phillips screwdriver (not included) and Wrench (not included)
- Note: The right and left sides of the griddle are designed as if you are facing the front of the griddle.



CALIFORNIA PROPOSITION 65 WARNING

1. Fuels used in gas burning appliances and the combustion byproducts of such fuels, can expose you to chemicals including carbon monoxide, which is known to the State of California to cause birth defects or other reproductive harm.
2. This product contains Nickel (Metallic) known to the State of California to cause cancer.
3. This product contains Lead and Lead Compounds known to the State of California to cause cancer and birth defects or other reproductive harm.

For more information, go to: www.P65Warnings.ca.gov

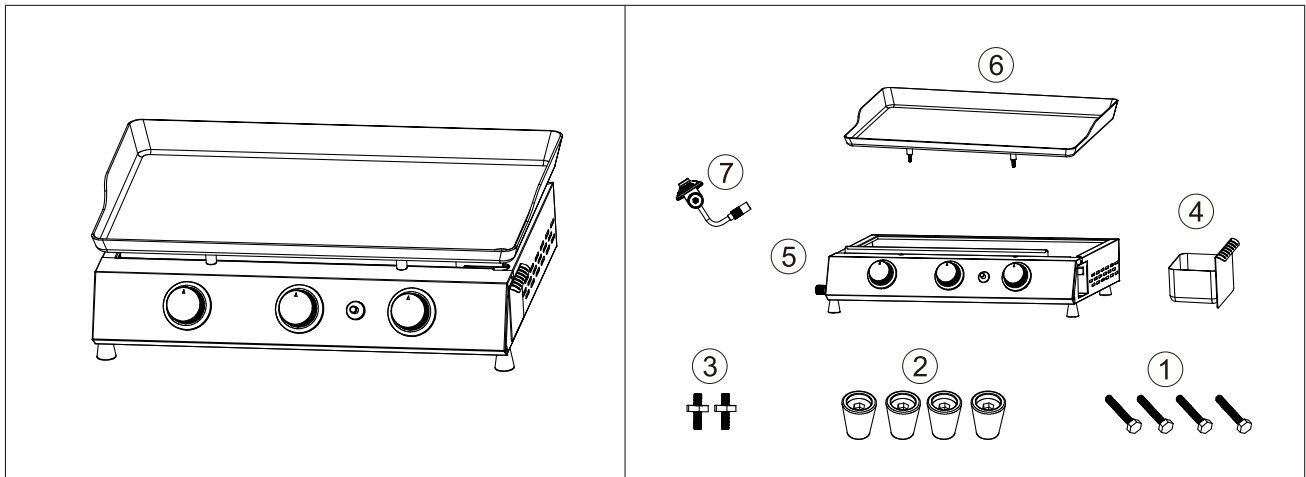

Ref	Description	Illustration	QTY
1.	Bolt (M4×30)		4
2.	Leg base JS206		4
3.	Stud with nut		2
4.	Grease cup GHLT5YB		1

Ref	Description	Illustration	QTY
5.	Main body		1
6.	Cooking griddle GHJP23B-C		1
7.	Regulator W-11020007		1

Step 1

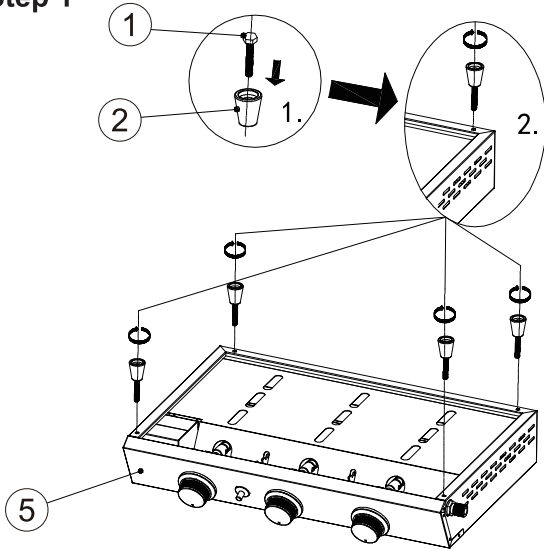

Insert 4 bolts (1) into the leg bases (2), then assemble 4 leg base assemblies to the bottom of the main body (5) by twisting clockwise until tightened.

Step 3

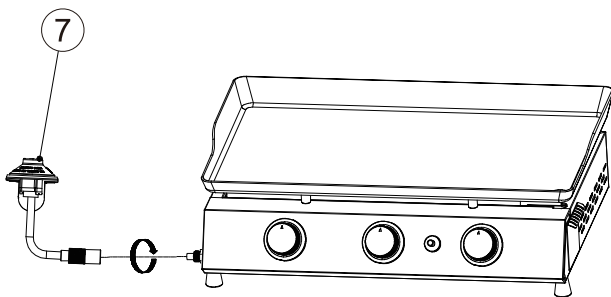

Connect the regulator (7) to the main body.

Step 5

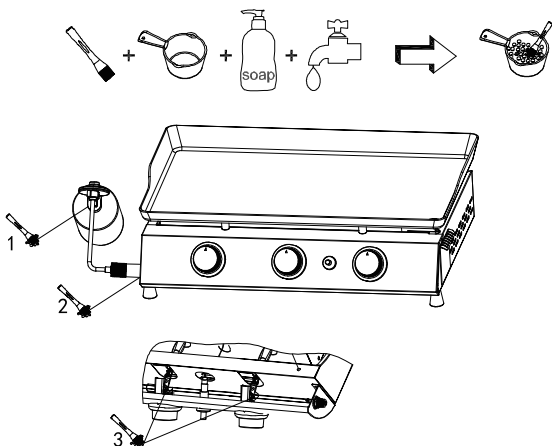

Before use, conduct the LP tank leak test as shown.

Step 2

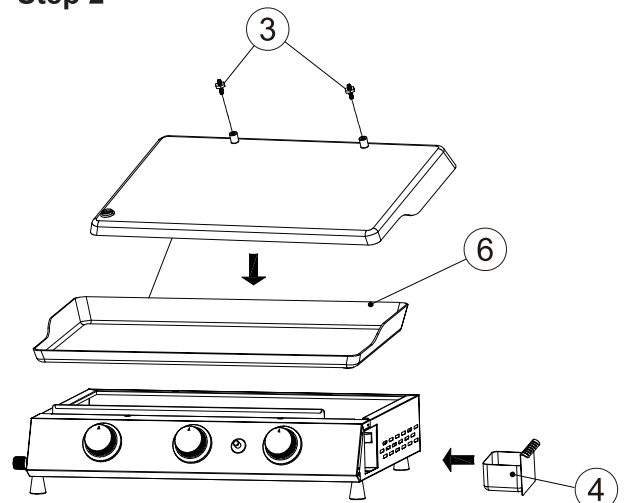

Insert the grease cup (4) to the side of the main body. Screw 2 studs (3) underneath the cooking griddle (6). Adjust the nuts to ensure the flatness of the griddle. It is recommended to leave a few inches of space from each nut to the griddle, as shown in the figure.

Step 4

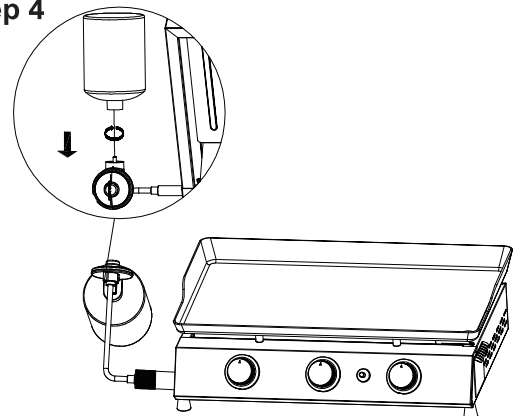

Insert the nipple of the regulator into the 1 lb. LP tank (not included) and hand tighten it by twisting clockwise as shown.

Step 6

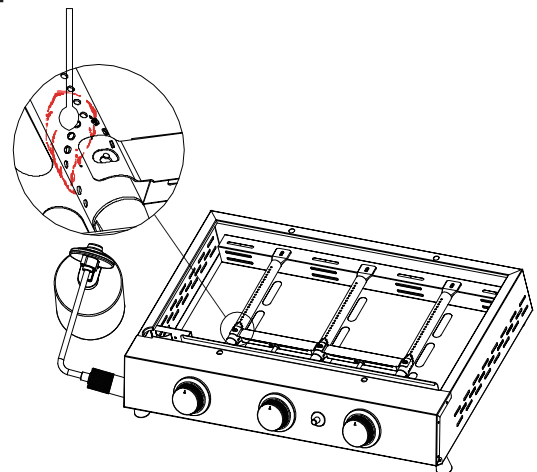

Consider to manually light the burner with a lit match stick as shown if failing to light the burner with piezo ignition.

INSTRUCTIONS FOR USE

Your new griddle has been designed and manufactured to high quality standards.

It will provide you with many years of fun grilling time, however, it requires a minimal amount of maintenance.

Follow these instructions carefully to avoid seriously damaging your grill and causing injury to yourself and to property.

1. Assemble the griddle as per the assembly instructions carefully.
2. Connect the 1lb. propane tank to the griddle (propane tank not included).
3. Turn all control knobs to the OFF position before turning on the gas supply to the griddle.
4. Operate the regulator in accordance with the instructions supplied with the regulator.

Always visually inspect your griddle before lighting. Look for anything that could block ventilation and remove such a blockage or move the griddle.

After lighting, check the flame pattern to ensure you have even heat distribution for each burner. If burners don't light up, or if the flame pattern is uneven, see the Troubleshooting section.

WARNING

1. Read instructions before lighting.
2. If ignition does not occur in 5 seconds, turn the burner control knob(s) off, wait 5 minutes and repeat the lighting procedure.

LIGHTING THE BURNERS USING PIEZO IGNITION

1. Turn all control knobs to OFF position.
2. Connect the LP tank to the regulator valve.
3. Push in control knob and turn it anti-clockwise to HI position. Push and hold ignitor button to light the burner.
4. If the burner does not ignite, turn control knob to OFF position, wait for 5 minutes before attempting to relight the burner.
5. If the burner ignites, repeat for other burners, and turn the control knobs to the temperature setting required for your food.

* Should the burners still fail to ignite, check the gas supply.

MANUALLY LIGHTING THE BURNERS WITH MATCH STICK

1. Turn all control knobs to OFF position.
2. Connect the LP tank to the regulator valve.
3. Remove the cooking griddle and place the lit match close to the burner ports.
4. Push in the control knob and turn it anti-clockwise to HI position. The burner should light immediately.
5. If the burner does not ignite, turn control knob to OFF position, wait for 5 minutes before attempting to relight the burner.
6. If the burner ignites, repeat for other burners, and turn the control knobs to the temperature setting required for your food.

* Should the burners still fail to ignite, check the gas supply.

TURNING OFF YOUR GRIDDLE

1. Turn all burner control knobs to OFF position.
2. Disconnect the LP tank from the regulator valve.

WARNING

Do not use spirit or petrol for lighting or re-lighting!

BEFORE USE PLEASE CHECK FOR LEAKS

Never check for leaks with a naked flame, always use a soapy water solution.

LEAK TEST

A leak test should be conducted each time a LP tank is refilled or exchanged.

Do not smoke or use any type of flammable material in the area during this leak test.

Do not use an open flame to check for leaks.

1. Test outside in a well-ventilated area.
2. Ensure the LP tank valve and all burners are at OFF position.
3. If the warnings 1 and 2 above are not strictly followed, there is risk of fire that may lead to serious injury or death.
4. Mix a 50/50 mild soap and water solution. Do not use any household cleaner solution.
5. Connect the regulator to the griddle, and connect the LP tank to the regulator, ensure the connections are secure, then open the LP tank valve. If you hear a rushing sound, disconnect the LP tank immediately. In that case, there could be a leak at the connection. Reconnect the LP tank to the regulator.
6. Spray or brush the soap water solution covering the following areas. (Fig. 1)
7. Bubbles that occur on any of the parts and connections listed above indicate a gas leak. Immediately disconnect the LP tank. Re-tighten the connections or order replacement parts as needed. Continue to test as necessary until no leaks are detected. If detected leakage can not be rectified, do not attempt to cure leakage but consult your gas dealer.
8. Disconnect the LP tank from the griddle after testing.

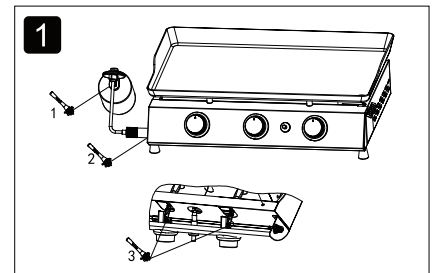

! If you smell gas:

1. Shut off gas supply to the griddle.
2. Extinguish any open flame.
3. If odor remains, keep away from the griddle and immediately call your fire department.

Failure to follow these instructions could result in fire, explosion, or burns, which could cause property damage, personal injury, or death.

LP TANK

1. The appliance must be used with a 1 lb. LP tank.
2. Do not drop or roughly handle the LP tank! If the appliance is not in use, LP tank must be disconnected. Replace the protective cap on the LP tank after disconnecting the LP tank from the appliance.
3. The LP tank must be stored outdoors in an upright position and out of the reach of children.
4. The LP tank must never be stored where temperatures can reach over 50 °C (122 °F).
5. Do not store the LP tank near flames, pilot lights, or other sources of ignition.
6. DO NOT SMOKE NEAR THE LP TANK. The LP tank should be kept away from any source of ignition.
7. Do not store or use gasoline or other flammable liquids or vapors in the vicinity of this or any other appliance.

WARNING

1. Do not clean any part of your griddle in a self-cleaning oven.
2. Do not use oven cleaners, abrasive kitchen cleaners, cleaners that contain citrus products, or mineral spirits.
3. Clean your griddle regularly to prevent grease buildup, grease fires or excessive flare-ups.
4. Always allow the griddle to cool down prior to cleaning.

CAUTION: All cleaning and maintenance should be carried out when the appliance is cooled down and with the fuel supply turned OFF at the LP tank or the regulator.

STAINLESS STEEL Clean with multipurpose, low-abrasion, non-phosphorous metal or stainless steel polish and a soft cloth. Always polish in the direction of the finish. Do not allow grease and dirt to accumulate. In addition, several products and naturally occurring substances can damage all stainless-steel finishes. These include, but are not limited to, swimming pool chemicals (chlorine and bromine), lawn and garden fertilizers, ice-melting products, sea or other salt water, urine, bird droppings, and tree sap. Upon contact with these substances, immediately wash and dry the stainless-steel surface and be careful to avoid burns.

COOKING GRIDDIE Most foods can be cleaned up by scraping and wiping down the cooking griddle with a paper towel or wet soft cloth. To remove tough food residue, you can use a mild cream cleaner and pad. You can also use soapy water or a paper towel and 1/4 cup of table salt as another method to clean your griddle. Rinse well and dry it.

OTHER EXTERIOR SURFACES Wash with a mild detergent and warm water. You can use a cloth, soft brush (non-metallic), or plastic cleaning pad. Rinse thoroughly and wipe dry.

GREASE CUP Check after each use. Remove and empty the grease cup when half full. It can be washed with warm water and mild dishwashing detergent.

BURNERS We recommend you clean your burners at least twice a year, or before each use if the griddle has not been used in over one month.

WARNING

Small insects and spiders may enter the burner tubes. Sometimes they will build nests or spin webs that can block or reduce the amount of gas flowing through the burner. You will usually see a smaller flame, or a flame that is mostly yellow rather than blue, coming from the burner when this happens. Other signs include the griddle generating uneven or low heat, or difficulty in igniting the burners. In cases of severe blockage, this can cause the flame to burn backwards, and outside of the burner tubes, which can damage your griddle and/or cause personal injury. **IMMEDIATELY SHUT OFF THE FLOW OF PROPANE GAS AT THE TANK OR SHUT OFF THE REGULATOR SHOULD THIS HAPPEN.** Wait for the griddle to cool down and then clean all burners.

CLEANING THE BURNERS

1. Ensure the gas is turned off at the LP tank.
2. Remove the cooking griddle.
3. Lift each burner up and out.
4. Clean the inside of the burner by using a stiff wire. An alternative is to use compressed air. Always wear protective gear for your eyes when using this method. Never enlarge the burner ports during cleaning.
5. Brush the outer surface of the burner.
6. Ensure all ports (holes) are free of debris.
7. Inspect the burners. Replace damaged parts that have cracks or enlarged ports.
8. Replace the cooking griddle.
9. Perform the Leak Test described earlier in this Owner's Manual.

WARNING

Proper placement of the burner and valve is vital to ensure safety.

BURNER FLAMES

Always check the burner flame patterns after lighting. A good flame should be primarily blue with a yellow tip and have a minimal amount of flicker. Some yellow tips are OK if they are smaller than 2.5 cm (1"). New burners sometimes have oil residue, which will cause yellow flame when burning off. Variations in gas supply, altitude, weather, and other factors can all impact burner performance. Older grills can also show more yellow flame due to food deposit, oil, and fat buildup.

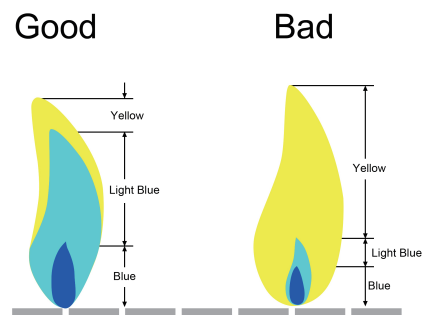

ALWAYS

1. Keep the grilling area clear and free from combustible materials, gasoline and other flammable vapors and liquids.
2. Do not obstruct the air flow for combustion and ventilation.
3. Keep the ventilation openings of the LP tank enclosure free and clear from debris.

GRIDDLE STORAGE

1. Clean your griddle before storage.
2. Storage of a gas griddle indoors is permissible only if the propane tank is disconnected and removed from the gas griddle.
3. Cover the griddle.
4. Perform a Leak Test before using the griddle after it has been kept in storage for some time.

BURNER WON'T LIGHT (USING A 0.45 KG (1 LB.) LP BOTTLE)

- Ensure LP bottle still has fuel in it by gently shaking it-there will be sounds of the liquid inside if the fuel remains.
- Check to see that the air inlet screen of the venturi tube is not covered or clogged.
- Check to see that burner orifices are clear. If obstructed, with LP bottle disconnected, you can gently brush orifices with a small brush.
- Check to see that the ignitor is producing a spark against the burner (better checked in shady spot). If the burner still doesn't ignite, repeat the above procedures with another LP bottle.

BURNER WON'T LIGHT (USING A 9 KG (20 LB.) GAS TANK WITH CONVERSION HOSE)

- Review all steps in the LP bottle section above.
- Ensure that the LP tank supply valve is open (turned counterclockwise until stop).
- Ensure that the orifices at both ends of the conversion hose are not obstructed or damaged.
- Straighten sharp kinks in the conversion hose.

GRIDDLE DOESN'T REACH HIGHT ENOUGH TEMPERATURE (USING A 0.45 KG (1 LB.) LP BOTTLE)

- Gently shake LP bottle to ensure enough fuel for working, there will be sounds of the liquid inside if fuel remains.
- Check to see that the air inlet screen of the venturi tube is not covered or clogged.
- Test the gas system for leaks.

GRIDDLE DOESN'T REACH HIGH ENOUGH TEMPERATURE (USING A 9 KG (20 LB.) GAS TANK WITH CONVERSION HOSE)

There is a safety device on your LP tank which intends to reduce the gas flow whenever a leak occurs. When this device is active, it is commonly called "bypass". This device can be inadvertently activated if you don't follow the proper lighting procedures. Once you experience the low flame, you should do the following:

- 1) Shut off the griddle.
- 2) Fully close the LP tank pressure relief valve.
- 3) Disconnect the conversion hose from the valve, and reconnect.

Then, restart with proper procedures:

- 1) Ensure the griddle control knob is turned to OFF position.
- 2) Slowly open the LP tank valve fully. Turn the LP tank hand wheel about 1/4 turn every 10 seconds.
- 3) WAIT 5 SECONDS.
- 4) Follow the lighting steps.

If your problem is not resolved using the troubleshooting information above,
please contact your local gas dealer.

Direct Heat

BEEF INTERNAL TEMPERATURE CHART			
Cooking Degree	Internal Core Temperature	Internal Description	Firmness
Rare	125 °F	Center is bright red, pinkish toward the outer portion, and warm throughout	Soft to the touch
Medium Rare	130-135 °F	Center is very pink, slightly brown toward the outer portion and slightly hot	Yields only slightly to the touch
Medium	140-145 °F	Center is light pink, outer portion is brown and hot throughout	Beginning to firm to the touch
Medium Well	150-155 °F	Mostly brownish gray throughout with a hint of pink in the center	Firm to the touch
Well Done	155 °F and above	Steak is brownish gray throughout	Firm or hard to the touch
POULTRY INTERNAL TEMPERATURE CHART			
Whole Chicken	165 °F	Cook until the juices run clear	Firm to the touch
Dark Meat	165 °F	Cook until white throughout but still moist	Firm to the touch
Breast Meat	165 °F	Cook until white throughout but still moist	Firm to the touch
Thigh, Wings and Legs	165 °F	Mostly brownish gray throughout with a hint of pink in the center	Firm to the touch
PORK INTERNAL TEMPERATURE CHART			
Medium	150 °F	Pink in the center	
Well Done	160 °F and above	Pork is uniformly white/brown throughout	
Pork Ribs	180-200 °F	Pale white. Cook medium to well done	
Raw Sausage	160 °F	No longer pink	
Sausage (Pre-cooked)	140 °F	No longer pink	

STEAK (& ALL MEATS):

- To grill meats, raise fire grate to high position (hot) and sear for one minute on each side with the lid open to seal in flavor and juices.
- Then lower the fire grate to the medium position with lid closed and cook to desired degree.
- Control heat with dual dampers and adjustable fire grate.

Tip:

Place grilled meat back in the marinade for several minutes before serving and it will be tastier and juicier.

CAUTION:

Boil extra marinade first to kill bacteria remaining from the raw meat.

MARINATED FLANK STEAK:

- Mix marinade ingredients in a nonmetal dish.
 - Let steak stand in marinade for no less than 4 hours in the refrigerator.
 - Brown each side for 5 minutes, but center should remain rare.
 - Cut steak diagonally across the grain into thin slices before serving.
 - Grill with fire grate in high (hot) position with lid open or closed.
-

Meat Marinade

- 1/2 cup vegetable or olive oil
 - 1/3 cup soy sauce
 - 1/4 cup red wine vinegar
 - 2 tbsp lemon juice
 - 1 tsp dry mustard
 - 1 minced clove garlic
 - 1 small minced onion
 - 1/4 tsp pepper
-

QUAIL OR DOVES:

- Cover the birds with good amount of seasoning and marinate overnight.
 - Pour remaining dressing and cover with Texas Pete Hot Sauce for 6 hours.
 - Wrap birds in thick bacon secured by a toothpick.
 - Place on grill. Keep turning until bacon is black.
 - Grill for 20 minutes. Sear with lid open and fire grate in high (hot) position for 1 minute on each side before lowering the grate and closing the lid.
 - To smoke the birds, place them in the center of the grates with fire in both ends of the fire box.
-

HOT DOGS :

- Grill with lid up and cooking grates in high (hot) position for approximately 6 minutes.
 - Turn every few minutes.
-

SWEET CORN IN HUSKS:

- Trim excess silk from end and soak in cold salted water for 1 hour before grilling.
 - Grill for 25 minutes (to turn several times).
-

KABOBS:

- Alternate any combination of meat, onions, tomatoes, green peppers, mushrooms, zucchini, circular slice of corn-on-the-cob, or pineapple on skewers. Meat could consist of shrimp, scallops, lobster, chicken, sausage, pork, beef, etc.
 - Marinate the meat in refrigerator for several hours.
 - Grill each side approximately for 7 minutes, turning occasionally while basting with marinade.
 - Leave a small amount of room between pieces in order to cook faster.
 - Grill with lid up and the cooking grates in the lowest position.
-

Kabob Marinade:

- 1 cup soy sauce
 - 1/2 cup brown sugar
 - 1/2 cup vinegar
 - 1/2 cup pineapple juice
 - 2 tsp salt
 - 1/2 tsp garlic powder
 - Mix all ingredients in a saucepan and bring to boil.
 - Allow marinade to cool before marinating your meat in it.
 - Marinate beef in the mixture a minimum of 4 hours.
-

HAMBURGERS:

- See meat marinade on prior pages.
 - You may also marinate by allowing to stand in marinade for 1 or 2 hours at room temperature before cooking or let it stand in a covered dish in the refrigerator for up to 24 hours.
 - Bring to room temperature before cooking.
 - Mix in chopped onions, green peppers, salt, sear 3/4 inch patties on each side, with cooking grates in high position for a few minutes.
 - Lower fire grate to medium position and grill with lid down to avoid flare-ups.
 - Cook each side for 3 to 7 minutes according to desired degree.
 - Cook ground meat to 150 °F internal temperature or until juice runs clear (free of blood) to prevent E-coli infections.
 - Burgers can be basted with marinade when turning and/or other ingredients can be mixed in with the ground beef such as chili sauce or powder.
-

SHRIMP (Peeled) & CRAYFISH:

- Place on skewers.
 - Coat with melted butter and garlic salt.
 - Grill for 4 minutes on each side or until pink. Cocktail sauce optional.
-

BAKED POTATOES:

- Rub with butter and wrap in foil and cook on grill with lid down for 50 minutes.
 - Turn after 25 minutes (no need to turn if smoked).
 - Squeeze to check if it is cooked.
-

Thanks for purchasing this Royal Gourmet® Griddle.

Royal Gourmet warrants its products to be free from defects in materials and workmanship under proper assembly, normal residential use and recommended care for **1-Year Full Warranty** from the date of original retail purchase. The warranty does not cover paint finish as it may burn off during normal use. **RUST is not considered a manufacturing or materials defect.**

For **5 Years** from the date of purchase, **any stainless steel burner** that rusts through will be replaced **free** of charge.

Within the stated warranty period, Royal Gourmet, at its discretion, shall replace defective components free of charge, with the owner being responsible for shipping. Royal Gourmet reserves the right to require that defective parts be returned, postage and or freight pre-paid by the consumer for review and examination. In the event of parts availability issues, Royal Gourmet reserves the right to substitute like or similar parts that are equally functional. Upon the expiration of such warranty, all such liability shall terminate.

Note: A dated sales receipt along with Model Number and Serial Number will be required for the warranty service.

The limited warranty will not reimburse you for the cost of any inconvenience, food, personal injury or property damage. All warranty coverage is void if this griddle is ever used for commercial or rental purposes. And this limited warranty applies to the functionality of the product **ONLY** and does not cover cosmetic issues such as scratches, dents, corrosions or discoloring by heat, abrasive and chemical cleaners or any tools used in the assembly or installation of the appliance, surface rust, or the discoloration of stainless steel surfaces.

ITEMS NOT COVERED IN THE WARRANTY SERVICE

Any failures or operating difficulties due to accident, abuse, misuse, alteration, misapplication, vandalism, improper installation or improper maintenance or service, or failure to perform normal and routine maintenance, including but not limited to damage caused by insects within the burner tubes, as set out in the owner's manual.

Deterioration or damage due to severe weather conditions such as hail, hurricanes, earthquakes or tornadoes, discoloration due to exposure to chemicals either directly or in the atmosphere.

Cost of service calls to your home.

Costs of removal or re-installation.

Pickup and delivery of your product.

Shipping or transportation costs.

Labor costs for installation and repair.

Liability for indirect, or consequential damages.

This limited warranty is the sole warranty given by Royal Gourmet and is in lieu of all other warranties, expressed or implied including implied warranty, merchantability, or fitness for a particular purpose. Neither Royal Gourmet nor the retail establishment selling this product has authority to make any warranties or to promise any remedies in addition to or inconsistent with those stated above.

Royal Gourmet's **maximum liability**, in any event, shall not exceed the purchase price of the product paid by the original consumer purchaser. Some states do not allow the exclusion or limitation of incidental or consequential damages. In such a case, the above limitations or exclusions may not be applicable.

Do not return parts without prior to obtaining return authorization from our customer service department.

Please do not hesitate to contact our customer service when you have any questions regarding assembly, warranty, or accessories. We will be happy to offer any replacement parts you need during the warranty period.



1-800-618-6798



service@royalgourmetusa.com



Mon-Fri, 8:30 AM-5:30 PM, EST