

This Owner's Manual is provided and hosted by [Appliance Factory Parts](#).



Royal Gourmet PD1202S Owner's Manual

[Shop genuine replacement parts for Royal Gourmet PD1202S](#)



[Find Your Royal Gourmet Grill Parts - Select From 56 Models](#)

----- Manual continues below -----

Stainless Steel-18 In Portable Gas Griddle

OWNER'S MANUAL

Series No.: 0702-E



WARNING:

- Use outdoors only.
- Read the instructions before using the appliance.
- Accessible parts may be very hot.
- Keep young children away.
- Do not move the appliance during use.

LIGHTING INSTRUCTION:

1. Turn off the control knob clockwise to "OFF" position.
2. Connect the regulator to the gas bottle.
3. Push down the control knob and keep pressing while turning the control knob to the highest air pressure. Pushing the knob up again. This should have a clicking sound which lets you know the knob is open.
4. If the burner has not lit, turn knob off, wait 3 minutes and repeat step 3.
5. Repeat step 3 to 4 for other burners.

FOR YOUR SAFETY!

Use outdoors only! Do not use it in a building, garage or any other enclosed areas. Read the instructions before assembling and using the appliance.

DO NOT use the griddle unless it is completely assembled and all the parts are securely fastened. This griddle will become very hot, do not move it during operation. Keep children and pets away.



Customer Service

☎ 1-800-618-6798

CONTACT US FIRST!

This griddle has been made to high quality standards.

If you have any questions that are not addressed in this manual, or you need parts, please call our customer service hotline or send an email to service@royalgourmetusa.com

Learn more at:

www.royalgourmetcorp.com

| | |
|--------------------------------------|--------------|
| For Your Safety | 2 |
| Preparation | 3 |
| Parts and Hardwares List | 4 |
| Assembly Instructions | 5-6 |
| General Safety Instructions | 7 |
| Connecting The Gas Cylinder | 8 |
| Cleaning and care | 9 |
| Trouble Shooting Guide | 10-11 |
| Grilling Recipes | 12-13 |
| Warranty and Customer Service | 14 |

1. DO NOT store or use gasoline or any flammable vapors or liquids within 25ft (8m) of the griddle.
2. When cooking with oil/grease, do not allow the oil/grease to exceed 177°C (350°F). DO NOT store extra cooking oil in the vicinity of the griddle.
3. A liquid propane (LP) tank (cylinder) not connected for use should be stored a minimum of 10ft (3m) away from griddle or any appliance. Never fill the gas cylinder beyond 80% full. If the above information is not followed exactly, a fire causing death or serious injury may occur.

Call us first! DO NOT return the griddle to the retailer. This griddle has been made to high quality standards. If you have any questions not addressed in this manual, or you need parts, please call the customer service hotline.

NOTE: The assembly and use of this griddle must conform to local codes. In absence of local codes, use the National Gas and Propane Instruction Code. Read all instructions prior to assembly and use.

CAUTION:

1. This griddle is for use with propane gas only (propane gas cylinder not included).
2. Never attempt to attach this griddle to the self-contained propane system of a camper trailer, motor home or house.
3. Never use charcoal or lighter fluid with gas griddles.
4. DO NOT use gasoline, kerosene, or alcohol for lighting, The LP gas cylinder must be constructed and marked in accordance with the specifications for propane gas cylinders of National Standard of America CAN/CSA-B339, Cylinder, Spheres, and Tubes for Transportation of Dangerous Goods. This griddle is not intended to be used in or on recreational vehicles and/or boats.
5. DO NOT attempt to move the griddle while it is lit or hot.
6. DO NOT use griddle unless it is completely assembled and all parts are securely fastened and tightened.
7. DO NOT use griddle or any gas products near unprotected combustible buildings and materials.
8. DO NOT use in the presence of gases or vapors. Keep griddle area clear and free from combustible materials, gasoline, and other flammable vapors and liquids.
9. DO NOT touch metal parts of the griddle until it has completely cooled (about 45 minutes) to avoid burns, unless you are wearing protective gear (oven mitts, pot holders, and etc.)
10. DO NOT alter griddle in any manner.
11. Keep all combustible items and surfaces at least 36 inches (91cm) away from the griddle at all times.
12. Clean and inspect the hose before each use. If there is evidence of abrasion, wear, cuts, or leaks, the hose must be replaced before operating the griddle. The replacement hose assembly must be as specified by the manufacturer.
13. Move gas hose as far away as possible from hot surfaces and dripping hot grease.
14. Never keep a filled gas cylinder in a hot car or truck. Heat will cause the gas pressure to increase, which may open the relief valve and allow the gas to escape.
15. Keep the griddle's valve compartment, burners and circulating air passages clean. Inspect the griddle before each use.

Before beginning assembly, make sure all parts are present. Compare parts with packaged contents list and diagram above. If any parts are missing or damaged, do not attempt to assemble the products. Contact customer service for replacement parts via telephone or email.



Phillips screwdriver



Slotted Screwdriver



Wrench

- Estimated assembly time: 20 minutes
- Tools required for assembly:
Phillips Screwdriver (not included) and Wrench (not included)
- Note: The right and left sides of the griddle are designed as if you are facing the front of the griddle.



CALIFORNIA PROPOSITION 65 WARNING

1. Fuels used in gas burning appliances and the combustion byproducts of such fuels, can expose you to chemicals including carbon monoxide, which is known to the State of California to cause birth defects or other reproductive harm.
2. This product can expose you to chemicals including nickel, which is known to the State of California to cause cancer. Handling the brass material on this product can expose you to lead, a chemical known to the State of California to cause cancer, birth defects or other reproductive harm.

For more information go to: www.P65Warnings.ca.gov

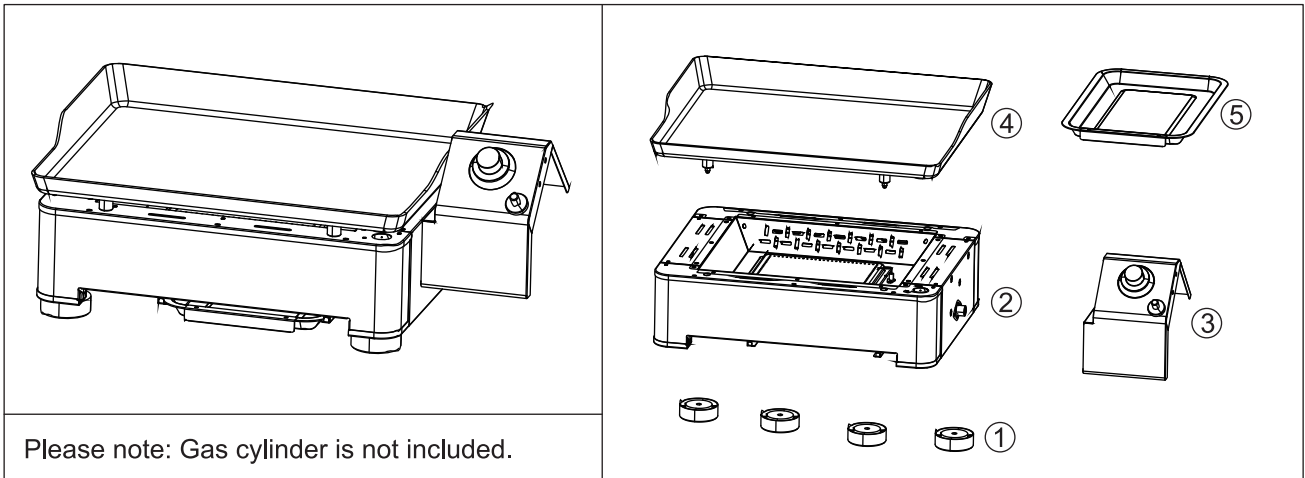

| Ref | Description | Illustration | QTY |
|-----|--------------------|--------------|-----|
| 1. | Foot W-SG20005 | | 4 |
| 2. | Main body | | 1 |
| 3. | Regulator GHMBH | | 1 |

| Ref | Description | Illustration | QTY |
|-----|------------------------------|--------------|-----|
| 4. | Cooking griddle GHJP22B-A | | 1 |
| 5. | Grease cup YP001 | | 1 |

| A | M6x30 | 4pcs | B | M6x10 | 4pcs | C | M4x12 | 4pcs | D | M6 | 2pcs |
|---|-------|------|---|-------|------|---|-------|------|---|----|------|
| | | | | | | | | | | | |

Step 1

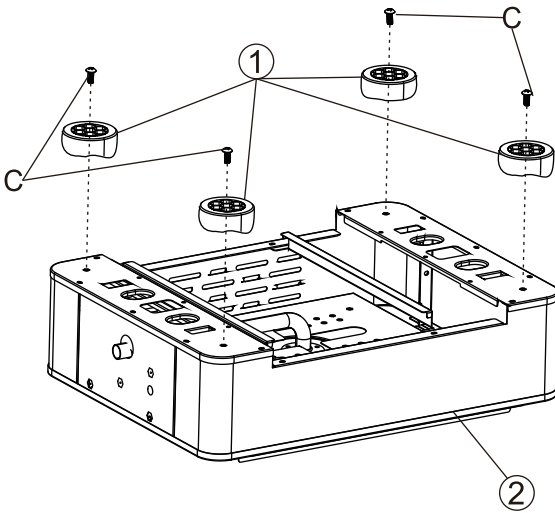

Assemble the feet (1) to main body with 4 bolts (C).

Step 2

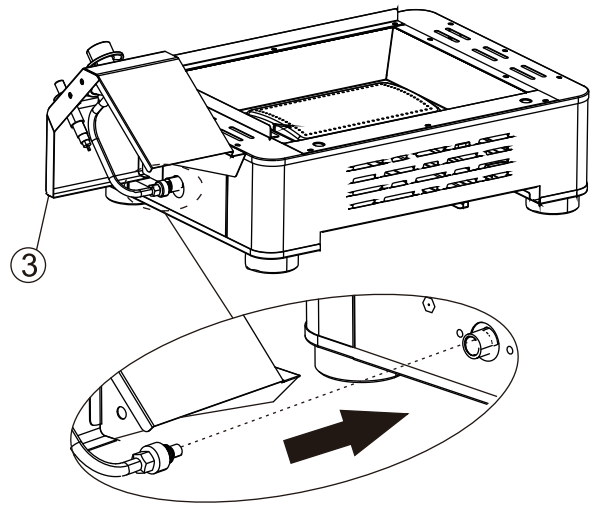

Connect the tube terminal to the main body, twist clockwise.

Step 3

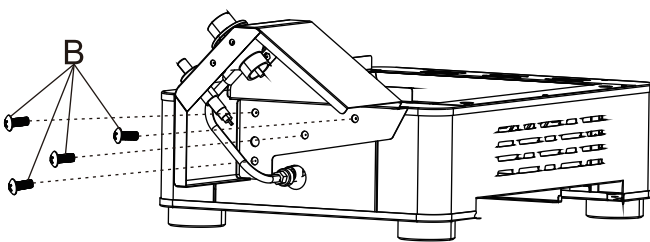

Assemble the regulator (3) to main body with 4 bolts (B).

Step 4

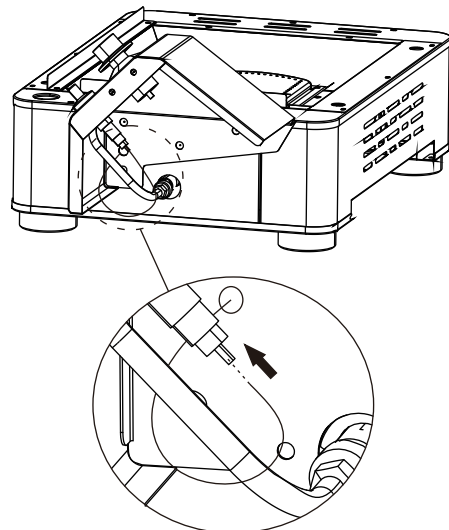

Insert the ignition line to the electrode hole as shown.

Step 5

If you found the griddle is not positioned horizontally on the body, please adjust one or more griddle foot until the griddle is horizontal to the body.

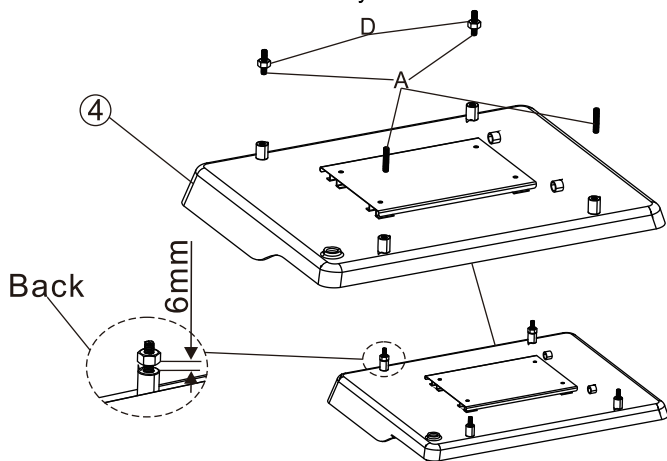

Twist 4 bolts (A) into 4 holes on the back of the cooking griddle. Screw 2 nuts (D) to the bolts.

Step 6

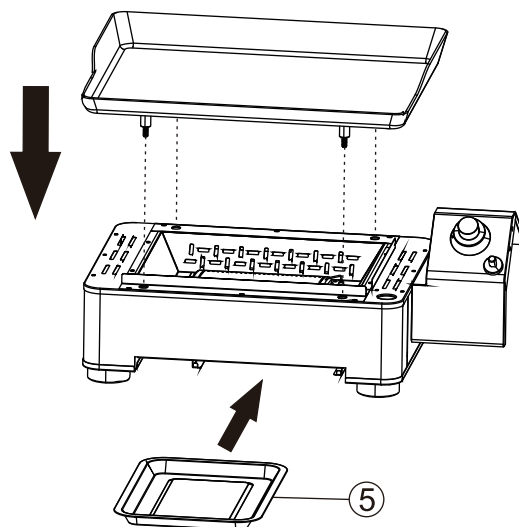

Place the griddle (4) onto the main body. Slide the grease cups (5) into the braces as shown.

Step 7

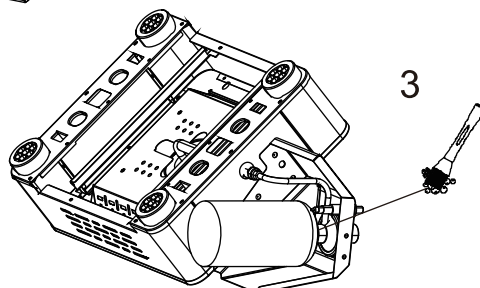
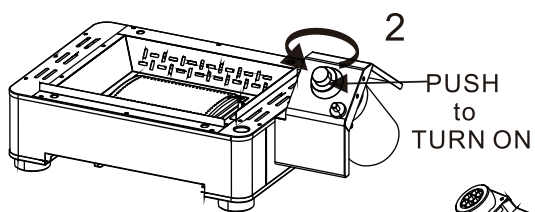
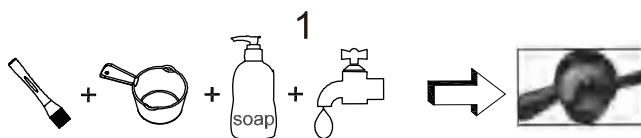

LP cylinder leak test

1. The griddle is safe and easy to use.
2. Please ensure you only use the griddle at the correct pressure which the appliance is designed for with a grease tray and a grease cup under the case.
3. Adequate ventilation is vital for combustion and efficient performance of the barbecue. This will ensure the safety of the user and other people in the vicinity of the area where the appliance is being used. Never use the appliance in any enclosed covered area.
4. When the wind speed is above 6.6ft/s, don't use gas griddle facing to the wind.
5. The appliance is designed for use outdoors only.
6. Warning! Accessible parts may be very hot. Keep young children away.
7. Read the instructions before using the griddle.
8. Do not move the griddle while in use.
9. Turn off the griddle at the cylinder valve or regulator after use.
10. Any modification to the griddle may be dangerous and may cause injury or property damage.
11. Any unauthorised modification of the appliance will invalidate the guarantee on this appliance.
12. The griddle must not have any overhead obstruction. E.g. trees, shrubs, lean-to roofs.
The griddle must be installed with a clearance of 3.3ft around the griddle.
13. The griddle must not be used near flammable materials. (Petroleum based products, thinners or any other solid object that carries a flammable warning label.)
14. Close the valve of the gas cylinder or the regulator after use.
15. The use of this griddle in enclosed areas can be dangerous and is PROHIBITED.

INSTRUCTIONS FOR USE

Follow these instructions carefully to avoid seriously damaging your griddle and causing injury to yourself and to property.

1. Assemble the griddle following the assembly instructions carefully.
2. Connect the 1 lb propane tank to the griddle.
3. Turn all of the control knobs to the "OFF" position before turning on the gas supply to the griddle.
4. Operate the regulator in accordance with the instructions supplied with the regulator.

LIGHTING YOUR GRIDDLE

Lighting Instructions

1. Turn the control knob clockwise to "OFF" position.
2. Connect the regulator to the gas bottle. Turn the gas supply "ON" at the regulator. Check with the use of soapy water for any gas leakage between the bottle and the regulator.
3. Push down the control knob and keep pressing while turning it anti-clockwise to the "Full rate" position.
Push ignitor button rapidly.
4. If the burner has not lit in 3-5 seconds, turn knob off, wait 5 minutes and repeat step 3.
5. Repeat step 3 to 4 for other burner.
6. Adjust the heat by turning the knob to the High/Low position.
7. To turn the griddle OFF: turn the cylinder valve or regulator switch to the "OFF" position and then turn all control knobs on the griddle clockwise to the "OFF" position.

WARNING

If the burner fails to ignite, turn all control knobs off (clockwise) and also turn the cylinder valve off. Wait five minutes before attempting to relight with ignition sequence.

This appliance is only suitable for use with low-pressure butane or propane gas and fitted with the appropriate low-pressure regulator via a flexible hose. The hose should be secured to the regulator and the appliance with hose clips. Please consult your LPG dealer for information regarding a suitable regulator for the gas cylinder.

BEFORE USE PLEASE CHECK FOR LEAKS

Never check for leaks with a naked flame, always use a soapy water solution

TO CHECK FOR LEAKS

1. Make 2-3 fluid ounces of leak detecting solution by mild dish soap liquid with 3 parts water.
2. Ensure the control valve is "OFF".
3. Connect the regulator to the cylinder and ON/OFF valve to the burner, ensure the connections are secure then turn ON the gas.
4. Brush the soapy solution on to the hose and all joints. If bubbles appear you have a leak, which must be rectified before use.
5. Retest after fixing the fault. Turn off the gas at the cylinder after testing.
6. If detected leakage can not be rectified, do not attempt to cure leakage but consult your gas dealer.

REGULATOR AND HOSE

1. Use only regulators and hose approved for LPG at the above pressures. The life expectancy of the regulator is estimated as 10 years. It is recommended that the regulator is changed within 10 years of the date of manufacture.
2. The use of the wrong regulator or hose is unsafe, always check that you have the correct items before operating the barbecue.
3. The hose used must conform to the relevant standard for the country of use. The length of the hose must be 5 fts (maximum). Worn or damaged hose must be replaced. Ensure that the hose is not obstructed, kinked, or in contact with any part of the barbecue other than at its connection.
4. The hose should not be twisted or kinked when attached to the gas cylinder.
5. No part of the hose should touch any part of the appliance. So site the cylinder out to the left hand side of the appliance at the maximum distant permitted by the hose length.

STORAGE OF THE APPLIANCE

Storage of an appliance indoors is only permissible if the cylinder is disconnected and removed from the appliance. When the appliance is not to be used for a period of time it should be stored in its original packaging and stored in a dry dust free environment.

GAS CYLINDER

1. The appliance must be used with 1 LB gas cylinder.
2. The gas cylinder should not be dropped or handled roughly! If the appliance is not in use, the cylinder must be disconnected. Replace the protective cap on the cylinder after disconnecting the cylinder from the appliance.
3. Cylinders must be stored outdoors in an upright position and out of the reach of children.
4. The cylinder must never be stored where temperatures can reach over 122°F.
5. Do not store the cylinder near flames, pilot lights or other sources of ignition.
6. DO NOT SMOKE. The cylinder should be changed away from any source of ignition.

CAUTION: All cleaning and maintenance should be carried out when the barbecue is cool and with the fuel supply turned OFF at the gas cylinder.

CLEANING

“ Burning off ” the barbecue after every use (for approx 15 minutes) will keep excessive food residue to a minimum.

OUTSIDE SURFACE

Use mild detergent or baking soda and hot water solution. Non-abrasive scouring powder can be used on stubborn stains, then rinse with water.

If the inside surface of the barbecue lid has the appearance of peeling paint, baked on grease build-up has turned to carbon and is flaking off. Clean thoroughly with strong hot soapy water solution. Rinse with water and allow to completely dry. NEVER USE OVEN CLEANER.

INTERIOR OF BARBECUE BOTTOM

Remove residue using brush, scraper and/or cleaning pad then wash with a soapy water solution. Rinse with water and allow to dry.

PLASTIC SURFACES

Wash with a soft cloth and hot soapy water solution. Rinse with water. Do not use abrasive cleaners, degreasers or a concentrated barbecue cleaner on plastic parts.

COOKING GRATE OR GRIDDLE

Use a mild soapy water solution. Non-abrasive scouring powder can be used on stubborn stains then rinse with water.

GREASE CUP

1. Please do not open the grease tray during use.
2. Please check the grease cup on time and take away the oil when 1/3 full.

CLEANING THE BURNER ASSEMBLY

1. Turn the gas OFF at the control knob and disconnect the cylinder.
2. Remove the griddle.
3. Clean the burner with a soft brush or blow clean with compressed air and wipe with a cloth.
4. Clean any clogged ports with a pipe cleaner or stiff wire (such as an opened paper clip).
5. Inspect burner for any damage (cracks or holes). If damage is found, replace with a new burner.
6. Reinstall the burner check to ensure that the gas valve orifices are correctly positioned and secured inside the burner inlet (venturi).
7. In some cases your barbecue will light back because of an insect crawling inside the burner venturi or a spider spinning its web inside the burner. This can be rectified by using a bottle brush inserted through the burner venturi and pushing into the burner over the burner length.
8. If condition persists consult your gas dealer.

| Emergencies | Possible cause | Prevention/ Solution |
|--|--|---|
| Gas leaking from cracked/cut/ burned hose | Damaged hose | Turn off gas at LP tank, if hoses is cut or cracked, replace hose. See LP tank lead test and connection regulator to the LP |
| Gas leaking from LP tank | Mechanical failure due to resting or mishandling | Turn off LP tank valve |
| Gas leaking from LP tank valve | Failure or tank valve from mishandling or mechanical failure | Turn off LP tank valve. Return LP tank to gas supplier |
| Gas leaking between LP tank and regulator connection | Improper installation, untight connection , failure of rubber seal | Turn off LP tank valve, remove regulator from cylinder and visually inspect rubber seal for damage, see LP tank test and connection regulator to the LP tank |
| Fire coming through control panel | Fire in burner tube section of burner due to partial blockage | Turn off control knobs and LP tank valve. After fire is out and griddle is cold, remove burner and inspect for spider nests or rust. see natural hazard and cleaning the burner assembly pages. |

| Troubleshooting: Problem | Possible cause | Prevention/ Solution |
|--|--|--|
| Grease fire or continuous excessive flames above cooking surface | Too much grease buildup in burner area | Turn off LP Tank. Leave lid open to allow flames to die down. After cooling, clean food particles and excess grease from inside firebox area, grease cup/pan/tray, and other surfaces |
| Burner will not light using ignitor | Gas issues 1. Trying to light wrong burner 2. Burner not engaged with control valve 3. Obstruction in burner 4. No gas flow 5. Vapor lock at coupling nut to LP tank 6. Coupling nut and LP tank valve not fully connected. | 1. See instructions on control panel and section in the Use and Care. 2. Make sure valve are positioned inside of burner tubes. 3. Ensure burner tubes are not obstructed with spider webs or other matted, see cleaning section of use and care 4. Make sure LP tank is not empty. If LP tank is not empty, refer to "sudden drop in gas flow." 5. Turn off knobs and disconnect coupling nut from LP tank. Reconnect and retry. 6. Turn the coupling nut approximately one-half to three-quarters |
| Burner will not light using ignitor | Electrical issues: 1. Electrode cracked or broken;" sparks at crack." 2. Electrode tip not in proper position 3. Wire and/or electrode covered with cooking residue. 4. Wires are loose or disconnected 5. Wires are shorting (sparking) between ignitor and electrode. 6. Push button sticks at bottom sparking between ignitor and electrode | 1. Replace electrode. 2. Tip of electrode should be pointing toward port hole in burner. The distance should be 1/8" to 3/16". Adjust if necessary. 3. Clean wire and or electrode with rubbing alcohol and clean swab. 4. Reconnect wires or replace electrode/ wire assembly. 5. Replace ignitor wire 6. Replace ignitor 7. Inspect wire insulation and proper connection. Replace wires if insulation is broken. |

| Troubleshooting: Problem | Possible cause | Prevention/ Solution |
|--|---|---|
| Burner will not match light | See "gas issues;" on previous page. 2. Improper method of match-lighting | 1. See "Pilot Gas Control Ignition" section of use and care. |
| Sudden drop in gas flow or low flame | 1. Grease buildup. 2. Excessive fat in meat. 3. Excessive cooking temperature | 1. Clean burners and inside of grill/ firebox 2. Trim fat from meat before grilling. |
| Flames blow out | High or gusting winds. Low on LP gas. Excess flow valve tripped. | Turn front of griddle to face wind or increase flame height. Refill LP tank. Refer to "sudden drop in gas flow" above. |
| Persistent grease fire | Grease trapped by food buildup around burner system. | Turn knobs to OFF. Turn gas off at LP tank. Leave lid in position and let fire burn out. After griddle cools, remove and clean all parts |
| Flashback... (fire in burner tube(s)) | Burner and burner tubes are blocked | Turn knobs to OFF. clean burner and/or burner tubes. See burner cleaning section of use and care manual |
| Flare-up | 1. Grease buildup. 2. Excessive fat in meat. 3. Excessive cooking temperature | 1. Clean burners and inside of griddle/ firebox 2. Trim fat from meat before grilling. 3. Adjust (lower) temperature |
| Unable to fill LP tank | Some dealers have older fill nozzles with worn threads. | Turn worn nozzles don't have enough "bite" to engage the valve. Try a second LP dealer. |
| One burner does not light from other burner(s) | Grease buildup or food particles in end of carryover tube | Clean carry-over tube with wire brush |

If your problem is not resolved from the information above, please Contact your local gas dealer.

Notes :

- Turn the burner on for 15 to 20 minutes. Ensure appliance is cold before continuing.
- Grids should be cleaned periodically by soaking and washing in soapy water.
- The interior surfaces of the griddle housing cover should also be washed with hot, soapy water. Use a wire brush, steel wool or a scouring pad to remove stubborn spots.
- Periodically check the burner to see that it is free from insects and spiders which may clog the gas system, deflecting gas flow. Ensure to clean venturi pipes on burner very carefully, make sure that there are no obstructions. We recommend that you use a pipe cleaner to clean the venturi pipe area.
- Any modifications of this appliance may be dangerous and are not permitted.

Safety Reminders

Stand your gas griddle on a safe level surface, away from inflammable items such as wooden fences or overhanging tree branches. Never use your gas griddle indoors!

Once lit do not move your gas griddle or leave it unattended.

Keep children and pets at a safe distance from the gas griddle.

Keep a fire extinguisher handy.

The gas griddle will become hot when in use, so handle lids etc. with the help of gloves.

Ensure that the appliance has completely cooled down before storing.

Direct Heat

| BEEF INTERNAL TEMPERATURE CHART | | | |
|---|----------------------------------|---|-----------------------------------|
| Degree of Doneness | Internal Core Temperature | Internal Description | Firmness |
| Rare | 125°F | Center is bright red, pinkish toward the exterior portion, and warm throughout | Soft to the touch |
| Medium Rare | 130-135°F | Center is very pink, slightly brown toward the exterior portion, and slightly hot | Yields only slightly to the touch |
| Medium | 140-145°F | Center is light pink, outer portion is brown and hot throughout | Beginning to firm to the touch |
| Medium Well | 150-155°F | Mostly gray-brown throughout with a hint of pink in the center | Firm to the touch |
| Well Done | 155°F and above | Steak is brown-gray throughout | Firm or hard to the touch |
| POULTRY INTERNAL TEMPERATURE CHART | | | |
| Whole Chicken | 165°F | Cook until the juices run clear | Firm to the touch |
| Dark Meat | 165°F | Cook until white throughout but still moist | Firm to the touch |
| Breast Meat | 165°F | Cook until white throughout but still moist | Firm to the touch |
| Thigh, Wings and Legs | 165°F | Mostly gray-brown throughout with a hint of pink in the center | Firm to the touch |
| PORK INTERNAL TEMPERATURE CHART | | | |
| Medium | 150°F | Pink in the center | |
| Well Done | 160°F and above | Pork is uniformly white/brown throughout | |
| Pork Ribs | 180-200°F | Pale white to tan. Cook medium to well done | |
| Sausage Raw Sausage | 160°F | No longer pink | |
| Sausage (Pre-cooked) | 140°F | No longer pink | |

STEAK (& ALL MEATS):

- Cook food on the charcoal side of the unit, directly above coals/heat.
- To grill meats, raise fire grate to high position (hot) and sear for one minute on each side with the lid open to seal in flavor and juices. Then lower fire grate to medium position with lid closed and cook to desired doneness.
- Control heat with dual dampers and adjustable fire grate.

Tip: Place grilled meat back in the marinade for several minutes before serving – it will become tastier and juicier.

CAUTION: Boil extra marinade first to kill bacteria remaining from the raw meat.

MARINATED FLANK STEAK:

- Mix marinade ingredients in nonmetal dish.
 - Let steak stand in marinade for no less than 4 hours in refrigerator.
 - Brown each side for 5 minutes, but center should remain rare.
 - Cut steak diagonally across the grain into thin slices before serving.
 - Grill with fire grate in high (hot) position with lid open or closed.
-

Meat Marinade

- 1/2 cup vegetable or olive oil
 - 1/3 cup soy sauce
 - 1/4 cup red wine vinegar
 - 2 tbsp lemon juice
 - 1 tsp dry mustard
 - 1 minced clove garlic
 - 1 small minced onion
 - 1/4 tsp pepper
-

QUAIL OR DOVES:

- Cover birds with good seasons and marinate overnight.
 - Pour remaining dressing and cover with Texas Pete Hot Sauce for 6 hours.
 - Wrap birds in thick bacon secured by a toothpick.
 - Place on grill. Keep turning until bacon is black.
 - Grill for 20 minutes. Sear with lid open and fire grate in high (hot) position for 1 minute on each side **before lowering grate and closing lid.**
 - To smoke and place birds in center of grates with fire in both ends of fire box.
-

HOT DOGS:

- Grill with lid up and cooking grates in high(hot) position for approximately 6 minutes.
 - Turn every few minutes.
-

SWEET CORN IN HUSKS:

- Trim excess silk from end and soak in cold salted water 1 hour before grilling.
- Grill 25 minutes – turning several times.

KABOBS:

- Alternating on skewers any combination of meat, onions, tomatoes, green peppers, mushrooms, zucchini, circular slice of corn-on-the-cob, or pineapple. Meat could consist of shrimp, scallops, lobster, chicken, sausage, pork, beef, etc.
 - Marinate the meat in refrigerator for several hours.
 - Grill each side approximately 7 minutes turning occasionally while basting with marinade.
 - Leave a small amount of room between pieces in order to cook faster.
 - Grill with lid up and the cooking grates in the lowest position.
-

Kabob Marinade:

- 1 cup soy sauce
 - 1/2 cup brown sugar
 - 1/2 cup vinegar
 - 1/2 cup pineapple juice
 - 2 tsp salt
 - 1/2 tsp garlic powder
 - Mix all ingredients in a saucepan and bring to boil.
 - Allow marinade to cool before marinating your meat in it.
 - Marinate beef in mixture a minimum of 4 hours.
-

HAMBURGERS:

See meat marinade on prior pages.

You may also marinate by allowing to stand in marinade for 1 or 2 hours at room temperature before cooking or let stand in covered dish in refrigerator up to 24 hours.

- Bring to room temperature before cooking.
 - Mix in chopped onions, green peppers, salt, sear 3/4 inch patties on each side with cooking grates in high position for a few minutes.
 - Lower fire grate to medium position and grill with lid down to avoid flare-ups.
 - Cook each side 3 to 7 minutes according to desired doneness.
 - Cook ground meat to 150 internally or until juice runs clear (free of blood) for prevention of E-coli.
 - Burgers can be basted with marinade when turning and/or other ingredients can be mixed in with the ground beef such as chili sauce or powder.
-

SHRIMP (Peeled) & CRAYFISH:

- Place on skewers.
 - Coat with melted butter and garlic salt.
 - Grill 4 minutes on each side or until pink. Cocktail sauce optional.
-

BAKED POTATOES:

- Rub with butter and wrap in foil and cook on grill with lid down for 50 minutes.
- Turn after 25 minutes (no need to turn if smoked).
- Squeeze to check for doneness.

Thanks for purchasing this Royal Gourmet® Portable Grill. We are here to help you maximize your enjoyment and appreciation of your new griddle. We provide a warranty for your product within the framework warranty condition under normal use of one year from the date purchase for all components covering defects and manufacturing errors.

Royal Gourmet's obligations are limited to the following:

- This warranty does not cover griddles that have been altered or damaged due to normal wear, rust, abuse, improper maintenance, improper use, or modifications, to the product. Repair labor is not covered.
- This warranty does not cover surface scratches or heat damage to the finish which is considered as normal wear.
- All warranty claims apply only to the original purchaser and require a proof of purchase verifying date of purchase.
- All parts that meet the warranty requirements will be shipped at no-charge via the discretion of the customer service department.
- Do not return parts without prior to obtain return authorization from our customer service department.

Except as stated above, Royal Gourmet Corp makes no other express warranty.

This warranty may give you specific legal rights that vary by state.

Please do not hesitate to contact our customer service when you have any questions regarding assembly, warranty, or accessories. We will be happy to offer any replacement parts you need during the time of warranty period.



1-800-618-6798



service@royalgourmetusa.com



Mon - Fri, 8:30 AM- 5:30 PM, EST