

This Owner's Manual is provided and hosted by [Appliance Factory Parts](#).



LENNOX HEARTH VIN Owner's Manual

[Shop genuine replacement parts for LENNOX HEARTH
VIN](#)



[Find Your LENNOX HEARTH Wood or Gas Stove Parts - Select From 25 Models](#)

----- Manual continues below -----



HEARTH PRODUCTS

INSTALLATION AND OPERATION MANUAL

Direct-Vent Gas Stove

ELITE™ SERIES

Retain These Instructions For Future Reference

P/N 775,227M Rev. D, 11/2008

A French manual is available upon request. Order P/N 775,227CF.
Ce manuel d'installation est disponible en français, simplement
en faire la demande. Numéro de la pièce 775,227CF.

In the Commonwealth of Massachusetts:

- Installation must be performed by a licensed plumber or gas fitter
- See Table of Contents for location of additional Commonwealth of Massachusetts requirements

Tested & Listed By  Portland Oregon USA
OMNI-Test Laboratories, Inc.
Report No. 50-S-11b-5



Vintage™ (VIN)

WARNINGS

- **Hot! Do not touch!** The glass and surfaces of this appliance will be hot during operation and will retain heat for a while after shutting off the appliance. Severe burns may result.
- Carefully supervise children in the same room as appliance.
- Suitable for installation into masonry or factory built fireplaces. These appliances may be installed in an after-market permanently located, manufactured (mobile) home (USA only), where not prohibited by local codes. This appliance is only for use with the type of gas indicated on the rating plate. This appliance is not convertible for use with other gases unless a certified kit is used.
- Lennox Hearth Products gas-burning appliances are designed for use as a supplemental heater. They are not intended for continuous use as a primary heat source.

WARNING: If the information in these instructions are not followed exactly, a fire or explosion may result causing property damage, personal injury or loss of life.

Do not store or use gasoline or other flammable vapors or liquids in the vicinity of this or any other appliance.

WHAT TO DO IF YOU SMELL GAS:

- Do not light any appliance.
- Do not touch any electrical switch; do not use any phone in your building.
- Immediately call your gas supplier from a neighbor's phone. Follow your gas supplier's instructions.
- If your gas supplier cannot be reached, call the fire department.

Installation and service must be performed by a qualified installer, service agency or the gas supplier.

AVERTISSEMENT : S'assurer de bien suivre les instructions données dans ce guide pour minimiser les risques d'incendie ou d'explosion pouvant entraîner des dommages matériels, des blessures ou la mort.

Ne pas entreposer ni utiliser d'essence ou d'autres produits ou liquides inflammables à proximité de cet appareil ou de tout autre appareil de chauffage.

QUE FAIRE SI VOUS SENTEZ UNE ODEUR DE GAZ:

- Ne pas tenter d'allumer l'appareil.
- Ne pas toucher aux interrupteurs électriques; ne pas utiliser un téléphone dans le bâtiment.
- Aller immédiatement chez un voisin pour téléphoner au fournisseur du gaz et suivre leurs instructions.
- Si le fournisseur de gaz n'est pas disponible, appeler les pompiers.

L'installation et l'entretien doivent être assurés par un installateur certifié, une société de service spécialisée ou le fournisseur de gaz.

IMPORTANT SAFETY AND WARNING INFORMATION

- ◆ **FOR YOUR SAFETY** do not install or operate your Vintage™ gas stove without first reading and understanding this manual. Any installation or operation of the appliance deviating from that which is stated in this manual **WILL** void the warranty and may be hazardous.
- ◆ **INSTALLATION AND REPAIR SHOULD ONLY BE DONE BY A QUALIFIED SERVICE TECHNICIAN. DO NOT ATTEMPT TO SERVICE THE APPLIANCE YOURSELF.**
- ◆ The stove should be inspected and cleaned before use and at least annually by a qualified service technician. More frequent cleaning may be required due to excessive lint from bedding material, carpeting, etc.
- ◆ It is imperative that control compartments, burners and circulating air passageways of the room heater be kept clean.
- ◆ Adequate clearances around the combustion chamber and accessibility clearances for servicing and proper operation must be maintained.
- ◆ Turn off the gas before servicing this appliance. It is recommended that a qualified service technician perform an appliance check-up at the beginning of each heating season.
- ◆ All installations must conform with all local, state and national codes. In the absence of local codes, the installation must conform with National Fuel Gas Code ANSI Z223.1-latest edition, also known as NFPA 54 (In Canada, the current CAN/CSA B149.1 installation code). Refer to the National Fuel Gas Code and local zoning and code authorities for details on installation requirements. Your Vintage gas stove must be vented to the outside in accordance with the latest edition of the National Fuel Gas Code.
- ◆ This gas stove **MUST** be vented directly to the outside and **MUST NEVER** be attached to a chimney serving a separate solid fuel burning appliance. Each gas appliance **MUST USE** a separate vent system. Common vent systems are **PROHIBITED**.
- ◆ Mobile home installations must conform with the Mobile Home Construction and Safety Standard, Title 24 CFR, Part 3280 (in Canada CAN/CSA Z240 MH), or, when such a standard is not applicable, the Standard for Mobile Home Installations, ANSI A225.1 - latest edition.
- ◆ The appliance, when installed, must be electrically grounded in accordance with local codes or in the absence of local codes, with the National Electrical Code, ANSI/NFPA 70 - latest edition. In Canada, the current CSA C22-1 Canadian Electrical Code - latest edition.
- ◆ Do not make any make-shift compromises during installation. Any modification or alteration may result in damage to the appliance or dwelling and will void the warranty, certification and listings of this unit.
- ◆ Failure to use manufacturer provided parts, variations in techniques and construction materials or practices other than those described in this manual may create a fire hazard and void the limited warranty.
- ◆ Your Lennox Hearth Products gas stove must be equipped for the proper fuel type and altitude at which it will be operated. Any operation outside the parameters outlined in this manual may result in a hazardous condition and will void the warranty. Please carefully read the sections pertaining to these subjects and/or be sure your appliance is properly equipped.
- ◆ Do not use this stove if any part has been under water. Immediately call a qualified service technician to inspect the appliance and to replace any part of the control system and any gas control which has been under water.
- ◆ Due to high temperatures, the stove should be located out of traffic areas and away from furniture and draperies.
- ◆ Children and adults should be alerted to the hazards of high surface temperature and should stay away to avoid burns or clothing ignition. Young children should be carefully supervised when they are in the same room as the Lennox gas stove. Clothing or any other flammable material should not be placed on or near the stove.
- ◆ Never use solid fuels such as wood, paper, cardboard, coal, or any flammable liquids, etc., in this appliance.
- ◆ Any grill, panel, or glass removed for service **MUST** be replaced prior to operating the stove. Do not operate appliance with the glass front removed, cracked or broken. Replacement of the glass should be done by a qualified service technician.
- ◆ **DO NOT USE** abrasive cleaner on the glass door assembly. **DO NOT ATTEMPT** to clean the glass door when it is hot.
- ◆ Lennox Hearth Products, its employees, or any of its representatives assume no responsibility for any damages caused by an inoperable, inadequate, or unsafe condition as a result of any improper operation, service or installation procedures, whether direct or indirect.
- ◆ **INSTALLER: THESE INSTRUCTIONS ARE TO REMAIN WITH THE HOME OWNER!**

CONGRATULATIONS ON THE PURCHASE OF YOUR NEW GAS APPLIANCE MANUFACTURED BY LENNOX HEARTH PRODUCTS.

When you purchased your new gas stove, you joined the ranks of thousands of individuals whose answer to their home heating needs reflects their concern for efficiency and our environment. We extend our continued support to help you achieve the maximum benefit and enjoyment available from your new gas stove. It is our goal at Lennox Hearth Products to provide you, our valued customer, with an appliance that will ensure years of trouble-free warmth and pleasure.

Thank you for selecting a Lennox Hearth Products gas stove as the answer to your supplemental home heating needs.

Sincerely, All of us at Lennox Hearth Products

TABLE OF CONTENTS

Cautions and Safety 2

Orifice Size / Altitude Adjustment 4

Codes and Approvals 4

New York City, New York (MEA) 4

Commonwealth Of Massachusetts Requirements 4

Pre-Installation.....5-7

Features 5

Packaging List..... 5

Ratings 5

Preparing your Vintage™ Stove for Installation..... 6

Dimensions 6

Pipe Clearances 6

Clearances to Combustibles..... 7

Installation.....8-9

Baffle and Log Set Installation 8

Log Set and Ember Installation 8

Side Insert Installation 9

Vent Installation10-15

Venting.....10

Residential and Mobile Home Installations10

Vent Considerations10

Vent Parts List11

Horizontal Vent Installation.....11

Snorkel Terminations12

Vertical Vent Installation.....12

Flue Restrictors13

Horizontal Terminations.....14

Vertical Terminations.....14

Horizontal Vent Termination Locations15

Gas Line Installation16

Gas Pressure Requirements.....16

LP and Natural Gas Supplies16

Operating Instructions17-20

Pre-Lighting Checklist.....17

Lighting Instructions.....17

Flame Color and Behavior18

Air Shutter Adjustment19

Quiet Operation.....19

Paint Curing19

Optional Blower19

Optional Wall Thermostat.....19

Operating Options.....20

Millivolt Control System20

Maintenance and Servicing21-22

Maintenance Checklist21

Millivolt and Systems Checks21

Vent Pipe Maintenance.....22

Opening and Removing Door.....22

Glass Door Cleaning and Maintenance22

Troubleshooting23

Replacement Parts24

Accessories25

Stove Labels.....26-27

Product Reference Information28

USING THIS MANUAL

Please read and carefully follow all of the instructions found in this manual. Please pay special attention to the safety instructions provided in this manual.

PRODUCT IS SUBJECT TO CHANGE WITHOUT NOTICE

ORIFICE SIZE/ALTITUDE ADJUSTMENT

For altitudes above 2,000 feet (In Canada 4,500 FT/1370 M), the orifice should be de-rated by 4% for every 1,000 feet to maintain the proper ratio of gas to air. Improper orifice sizing may result in damage and unsafe conditions. Changing the orifice should only be done by a qualified service technician. Contact your Lennox Hearth Products dealer for proper orifice sizes.

SMOKE DETECTORS

Since there are always several potential sources of fire in any home, we recommend installing smoke detectors. If possible, install the smoke detector in a hallway adjacent to the room (to reduce the possibility of occasional false activation from the heat produced by the appliance). If your local code requires a smoke detector be installed within the same room, you must follow the requirements of your local code. Check with your local building department for requirements in your area.

CODES AND APPROVALS

Certification

Gas appliances must be tested and certified by a nationally recognized testing and certification laboratory to ANSI (American National Standard Institute) gas appliance safety standards.

This stove has been tested and certified by OMNI -Test Laboratories to ANSI Z21.88 / CSA 2.33 Standard for Vented Gas Fireplace Heater and CGA 2.17-M91 and UL 307B Gas Burning Heating Appliances for Manufactured (Mobile) Homes in both USA and Canada.

It has met all necessary ANSI Standards and is fully certified for installation in any community. If there are any questions or if you need further substantiation either write to or call your Lennox Hearth Products dealer. If you have further questions, please contact Lennox Hearth Products.

Check all local building and safety codes before installation. The installation instructions and appropriate code requirements must be followed exactly and without compromise. In the absence of local codes the following standards and codes must be followed.

THE VINTAGE™ STOVE

- Must conform with all local, state and national installation codes. In the absence of local codes, the installation must conform with National Fuel Gas Code ANSI Z223.1 - latest edition, also known as NFPA 54 (In Canada, the current CAN/CSA B149.1 installation code). Refer to the National Fuel Gas Code and local zoning and code authorities for details on installation requirements.
- Mobile home installations must conform with the Mobile Home Construction and Safety Standard, Title 24 CFR, Part 3280 (in Canada CAN/CSA Z240 MH), or, when such a standard is not applicable, the Standard for Mobile Home Installations, ANSI A225.1 - latest edition.
- Must be vented directly to the outside in accordance with the latest edition of the National Fuel Gas Code and must never be attached to a chimney serving a separate solid fuel burning appliance.
- Has been certified for use with either natural gas or propane.
- Is not for use with solid fuels.
- Is approved for sitting rooms and/or bedrooms.

NEW YORK CITY, NEW YORK (MEA)

Installation of these fireplaces are approved for installation in New York City in the US state of New York (MEA#: 138-07-E).

COMMONWEALTH OF MASSACHUSETTS REQUIREMENTS

(Massachusetts Approval #G3-0806-6)

These fireplaces are approved for installation in the US state of Massachusetts if the following additional requirements are met:

- Install this appliance in accordance with Massachusetts Rules and Regulations 248 C.M.R. Sec. 5.08 2(a) through 2(e).
- Installation and repair must be done by a plumber or gas fitter licensed in the Commonwealth of Massachusetts.
- The flexible gas line connector used shall not exceed 36 inches (92 centimeters) in length.
- The individual manual shut-off must be a T-handle type valve.

Massachusetts Horizontal Vent Requirements

In the Commonwealth of Massachusetts, horizontal terminations installed less than seven (7) feet above the finished grade must comply with the following additional requirements:

- A hard wired carbon monoxide detector with an alarm and battery back-up must be installed on the floor level where the gas fireplace is installed. The carbon monoxide detector must comply with NFPA 720, be ANSI/UL 2034 listed and be ISA certified.
- A metal or plastic identification plate must be permanently mounted to the exterior of the building at a minimum height of eight (8) feet above grade and be directly in line with the horizontal termination. The sign must read, in print size no less than one-half (1/2) inch in size, GAS VENT DIRECTLY BELOW. KEEP CLEAR OF ALL OBSTRUCTIONS.

PRE-INSTALLATION

Features

Installation Options

- Residential
- Vented vertical and horizontal
- Manufactured (mobile) home
- Natural gas (NG) or propane (LP)
- Bedrooms
- Optional wall-mounted or remote thermostat

Venting

This stove can be vented with Security™ Secure Vent™ pipe*. Coaxial pipe diameters are 6-5/8" outer and 4" inner. The combustion air for this stove is drawn from outside the house through the outer DV (direct vent) pipe. Room air is not required for combustion.

When planning your installation, select the correct length of vent pipe for your particular requirements. Determine the minimum clearance to combustibles from the rear of the unit to the wall. It is also important to note the thickness of the wall. Before cutting the vent hole through the wall make sure that ALL vent and termination clearances (see **Page 15**) will be met.

Electrical

The standard fan motor requires 120 Volts AC for operation. The stove is not dependent on the fan or an outside electrical supply to operate.

WARNING - Electrical Grounding Instructions - This appliance is equipped with a three-prong (grounding) plug for your protection against shock hazard and should be plugged directly into a properly grounded three-prong receptacle. Do not cut or remove the grounding prong from this plug.

* Other approved chimney brand is Simpson Dura-Vent DV-GS.

Millivolt Valve

This stove is operated with a millivolt valve and therefore burns even during a power outage.

Fuel

This stove comes from the factory equipped to burn natural gas at a specified elevation. The stove can be converted to burn LP gas (liquid propane) by changing the cassette (valve and pilot assembly) or installing a conversion kit. Only Lennox Hearth Products conversion kits can be used to convert from NG to LP or LP to NG. Contact your Lennox Hearth Products dealer for details.

Specifications

- Stove weight: 150 lbs
- Pipe: Type - direct-vent
- Recommended manufacturer*
Security™ Secure Vent™*
Diameter - 6-5/8" x 4" for all installations

Stove Packaging List

The **Vintage™ gas stove** comes with the following parts:

- 1 Stove Body with Burner Cassette
- 1 Log Set
- 1 Bag of Ember Material
- 1 Bag of the volcanic stone.
- 1 Installation and Operation Manual

Optional Parts

- 150 CFM Blower
- Reversible Cast-Iron Panels
- Gallo Veneziano Stone Panels
- Remote Controls
- Digital Wall Thermostat Kit

Note: See Pages 24 and 25 for ordering information.

RATINGS	Vintage™ (VIN)	
	NATURAL GAS	LP GAS
Max/Min Input BTUh 0-2,000 Feet (0-610 M) ❶	27,000 / 19,500	27,000 / 21,300
Manifold Pressure (IN. WC)	3.5 / 1.8	10.0 / 6.0
Min. Inlet Pressure (IN. WC)	5.0	11.0
Maximum heat output BTUs/hour-steady state	22,140	22,140
P4 Efficiency ENERGUIDE ❸	47.00%	49.07%
Orifice (DMS) 0-2,000 Feet (0-610 M) ❶	#40/.098 IN.	#53/.060 IN.

- ❶ Unit factory equipped for 0-2000 FT/0-610 M, In Canada 0-4500 FT/0-1370 M
 - ❷ The Steady State Efficiency numbers based on maximum vent configuration.
 - ❸ Tested to CSA P.4.1-02 "Testing Method for Measuring Annual Fireplace Efficiency."
- Electrical Rating: 120 VAC, 60 HZ, Less Than 2 Amps**

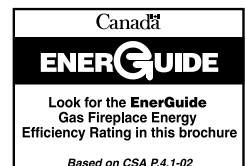

Preparing Your Vintage™ Stove For Installation

Read all instructions before beginning your installation. If instructions have not been read carefully, your installation could void your warranty and may create a serious fire, health, or other safety hazard.

The Lennox Hearth Products warranty will be voided if one of the following occurs:

- Installation of any damaged stove or vent system component.
- Unauthorized modification of the direct vent system.
- Installation other than as instructed by Lennox Hearth Products, Security™ Chimneys, or Simpson Dura-Vent.
- Installation of any stove or vent system component not manufactured or approved by Lennox Hearth Products, Security™ Chimneys, or Simpson Dura-Vent.

When planning the installation for your Vintage, it's necessary to consider the following:

- Where the unit is to be installed
- The vent system configuration to be used
- Gas supply (NG or LP)
- Electrical wiring
- Optional accessories (blower, wall-mounted or remote thermostat, cast-iron panels or stove panel inserts)

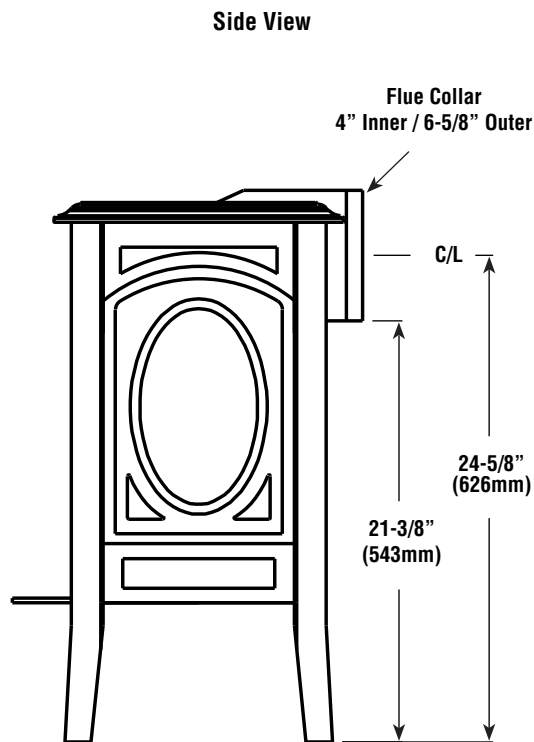

Figure 1

Dimensions

The gas line screws into the gas valve at the back of the stove 5" in from the right side of the stove and 4-3/16" up from the base of the unit.

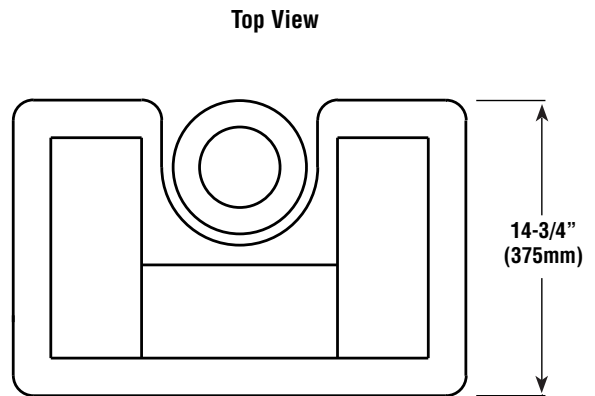

Figure 2

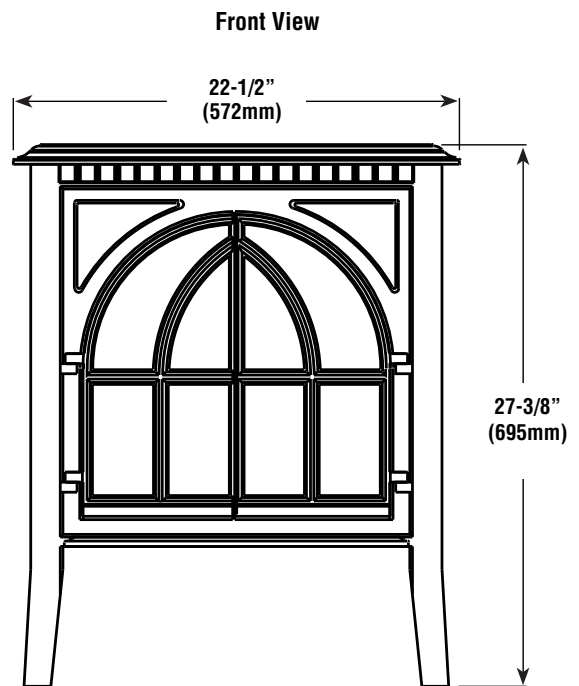

Figure 3

Pipe Clearances

All installations using a vertical termination cap must maintain one inch clearance between the direct vent pipe and combustibles. For horizontal runs of pipe, one inch of clearance to combustibles on the sides and bottom and two inches on the top of the pipe is required. See **Pages 12, 13 and 14** for allowable pipe configurations.

Clearances to Combustibles

Minimum clearances to combustible materials shown here are in inches (millimeters). See **Page 6** for pipe clearances.

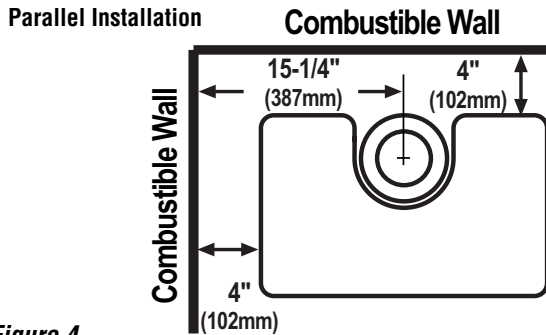

Figure 4

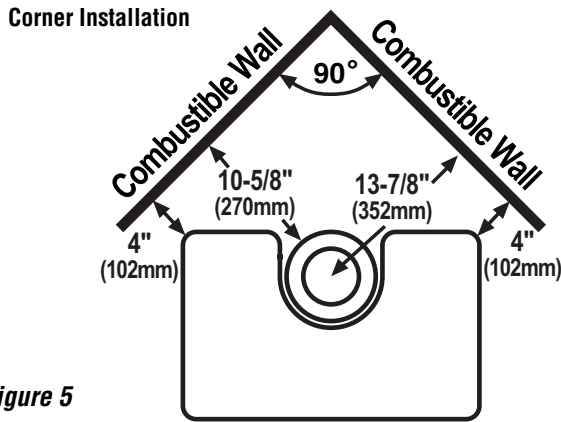

Figure 5

Floor Protection

A non-combustible hearth pad is not required. This stove may be installed on a combustible surface as long as the combustible material (such as carpeting) does not extend 1-1/2" vertically above the bottom of the legs (see **Figure 6**). Also, the floor beneath the stove must be stable, level, hard and strong enough to support the stove without a tipping hazard.

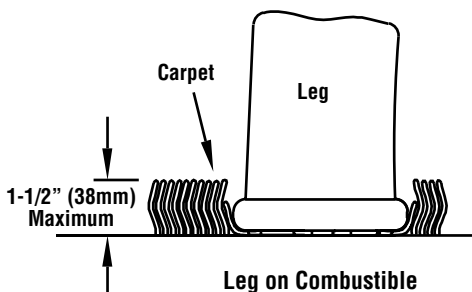

Figure 6

Alcove dimensions

The minimum width between alcove side walls is 30-1/2" (775mm). The glass door lifts up to access the firebox on the stove. Therefore, if the stove is to be installed in an alcove, the alcove needs to be constructed to allow for removal of the glass door. Option 1: The maximum alcove depth is 15" (381mm) (maintaining a 4" [102mm] rear clearance the stove will be positioned partly into the room) and the remaining minimum dimensions to combustibles are as shown in the Option 1 drawing below. Option 2: The alcove is 43" (1092mm) high to provide sufficient space to remove the door. The maximum depth of the alcove is 24" (610mm). Option 3: Should an alcove depth from 2 feet (.61M) to 4 feet (1.22M) be desired then the minimum alcove height is 54" (1372mm). Access to the stove's controls should be considered when determining the alcove size.

Alcove Option 1

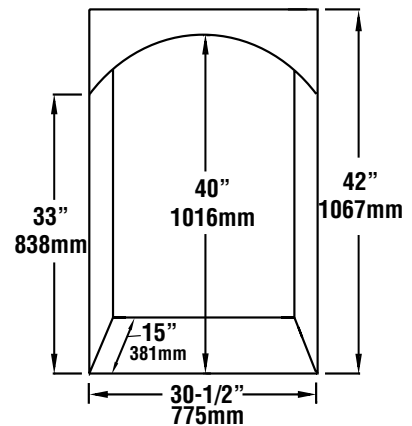

Figure 7

Alcove Option 2

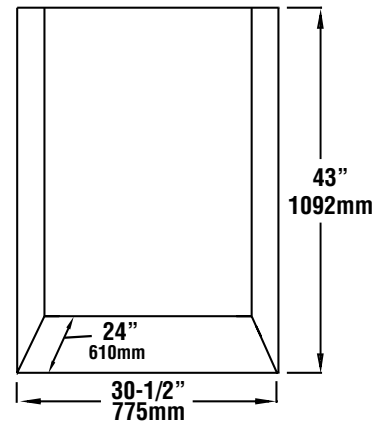

Figure 8

Alcove Option 3

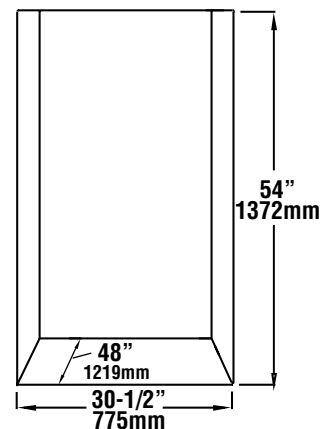

Figure 9

INSTALLATION

Baffle and Log Set Installation

Baffle

The cast iron baffle is wrapped in foam and shipped between the outside of the firebox and the outer shell of the stove. Remove the foam and install the baffle in the rectangular hole in the top of the firebox. The baffle rests unsecured in the hole.

Log Set and Embers

Firebox Accessories / Parts	
Cat. No.	Description
H5861	Log Set
H5863	Bag of Embers (volcanic stone)
H5864	Bag of Rockwool (glowing embers)
H5865	Bag of Steel Wool

Log Installation Instructions

If logs are not installed according to the log installation instructions, flame impingement and improper combustion could occur and result in soot and/or excessive production of carbon monoxide (CO), a colorless, odorless, toxic gas.

The size and position of the log set is critical to achieve a safe, reliable and attractive flame pattern. Any attempt to use a different log set in the fireplace will void the warranty and will result in incomplete combustion, sooting and poor flame quality.

Parts list: rear log, left front log, right front log and straight twig

- 1) Remove the logs from the box and carefully unwrap them. The logs are fragile so handle them with care.
- 2) Align the holes in the bottom of the rear log (the longest log in the set) with the two pegs just to the rear of the rear burner tube and slide the log down onto the pegs (**Figure 10**). The charred black surface of the log should face the front.
- 3) The left front log has two pegs protruding from the top surface (**Figure 11**). The charred black with white highlights surface of the log should be facing forward. Slide this log down onto the left front and center front pegs.
- 4) The right front log (positioned with the black charred surface towards the front) should be placed on the peg protruding from the right end of the left front log and the remaining peg at the right end of the metal log support panel (**Figure 11**).
- 5) The remaining straight twig has two holes in the bottom. Position the twig so the black and white charring is to the front and slide the holes over the peg in the left front log and the peg in the rear log (**Figure 12**). It may be necessary to roll the top of the rear log slightly forward to put this twig on the pegs.
- 6) **Figure 13** shows the entire log set assembled. The embers provided may be placed one high in front of the front burner tube using care not to cover all the burner ports. Any extra embers may be placed at the ends of the front log, off the burner. Place small pinches of rockwool on top of the embers.

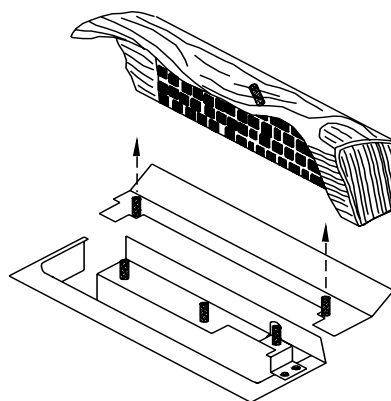

Figure 10

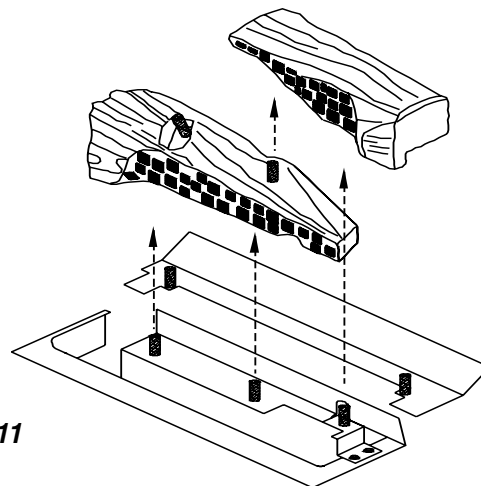

Figure 11

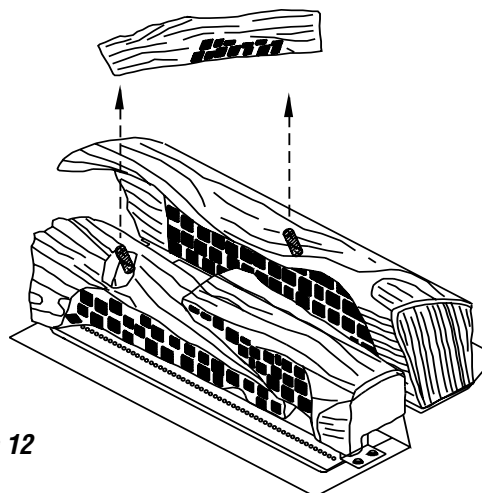
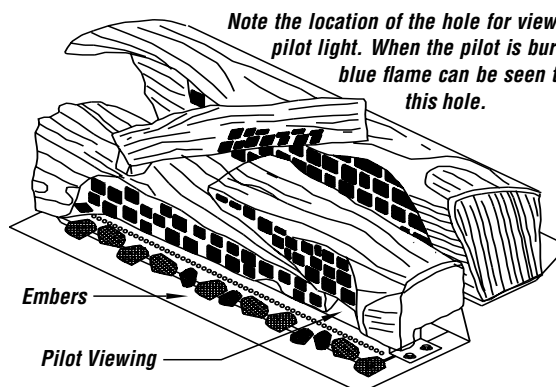

Figure 12



Note the location of the hole for viewing the pilot light. When the pilot is burning, a blue flame can be seen through this hole.

Figure 13

Side-Insert Installation

Follow these steps to install the cast iron inserts or your own custom stone inserts in the Vintage™ gas stove:

1. Remove the cast iron top and set it aside.
2. Remove the cast iron upper piece A - see Figure 14. Complete this step by unscrewing the (2) 5/32 hex-head screws labeled B in Figure 17. Lift out the upper cast piece A with the retaining bracket D attached.
3. Slide the cast iron or stone side inserts (size 15.5" x 10.5") (with the desired surface facing out) in behind the lower retaining bracket E. See Figures 15, 16 and 17. Note that the cast iron inserts are reversible - both sides have different designs.
4. Slide the heatshield (with the bent edges toward the cast or stone inserts - Figure 15) in between the cast or stone insert and the lower retaining bracket E.
5. Put the cast iron upper piece A back in its original location while making sure that the upper retaining bracket D is to the inside of the heatshield pushing it up firmly against the cast or stone insert - Figure 16. Reinstall the 2 screws B.
6. Reinstall the top.

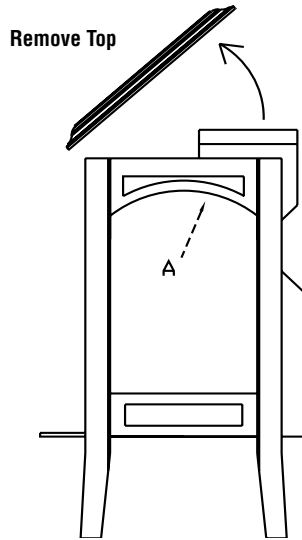

Figure 14

Bent Edge Toward the Stone or Cast Insert

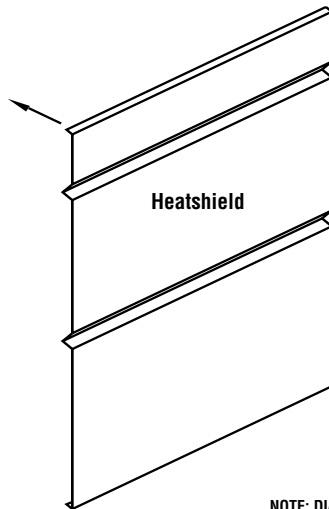

Figure 15

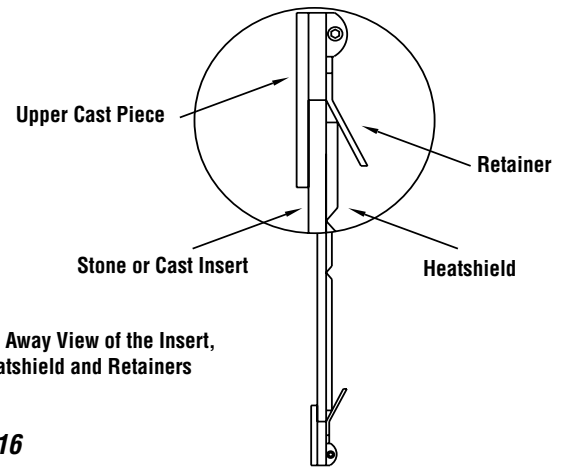

Figure 16

Side of the Vintage Viewed from the Inside Looking Out

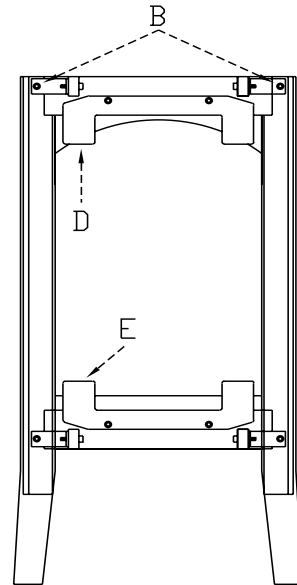

Figure 17

Tile Inserts

Should a Vintage owner prefer, tile can be used as the top and side inserts. The top inserts are 10-3/4" x 4-3/8" and the side inserts are 15-1/2" x 10-1/2". The stove can accommodate tile up to 1/2" thick. If 12" x 12" tile are used to make the side inserts, a seam will result. The tile and the heatshield should be positioned so the seam between the two pieces of tile is located between the two bends on the heatshield (see Figure 18). Also note that the seam and the heatshield can be rotated 180 degrees so the seam and the heatshield bends are on the bottom.

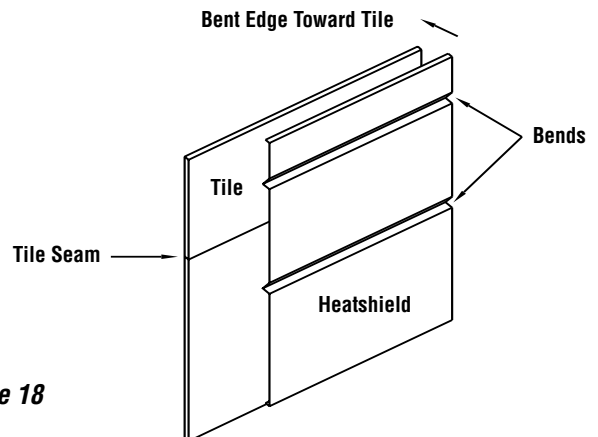

Figure 18

NOTE: DIAGRAMS & ILLUSTRATIONS ARE NOT TO SCALE.

Vent Installation

VENTING:

The Vintage™ gas stove has been tested and listed as a direct vent heater system by OMNI-Test Laboratories, Beaverton, Oregon and is recommended for use with Security™ Secure Vent pipe*.

Important:

- Read all instructions carefully before starting the installation. Failure to follow these instructions may create a fire or other safety hazard and will void the warranty. Be sure to check for specific clearances to combustible requirements on **Page 6**. **Do not extend the venting system vertically or horizontally in excess of the distance prescribed on Page 14.** Consult your local building codes before beginning the installation.
- **Always maintain the proper air spaces between the vent pipe and nearby combustibles to prevent a fire hazard.** Do not fill air spaces with insulation. Be sure to check the vent termination clearance requirements from decks, windows, soffits, gas regulators, air supply inlets and public walkways, as specified in these installation instructions on **Page 15** and local building codes.
- **This gas appliance and vent system must be vented directly to the outside of the building and never be attached to a chimney serving a separate solid fuel or gas-burning appliance.** Each direct vent gas appliance must use its own separate vent system. Common vent systems are prohibited.
- The Vintage is recommended for use with Security™ Secure Vent pipe*. The appliances and vent manufacturers warranties will be voided and serious fire, health, or other safety hazards may result from any of the following actions:
 - Installation of any damaged direct vent component.
 - Unauthorized modification of the direct vent system.
 - Installation of any vent component part not approved or manufactured by the approved vent manufacturer.
 - Installation other than as instructed by Lennox Hearth Products and vent manufacturers instructions.

Residential and Mobile Home Installations:

These are the minimum pieces required. Other parts may be required for your particular installation.

Minimum Components for Horizontal Installation:

Horizontal Termination Kit which includes:

- 1 6-5/8" x 6" Black Pipe
- 1 Riser Vent Terminal
- 1 Wall Penetration Heat Shield (Wall Thimble) (2 pcs)
- 1 Decorative Wall Trim (black)
- 1 Tube Mill-Pac
- Screws

Optional Components:

- 45° Elbow
- Vinyl Siding Shield for Riser Vent Terminal
- Vent Guard
- Snorkel Termination (36")
- Snorkel Termination (14")
- Wall Penetration Heat Shield

Vent Considerations:

Twist-lock procedure: Four indentations on female ends of pipes and fittings are designed to slide straight onto male ends of adjacent pipes and fittings by orienting the four pipe indentations so they match and slide into the four entry slots. Push pipe sections completely together, then twist-lock one section clockwise approximately one-quarter turn until the two sections are fully locked. The female locking lugs will not be visible from the outside on the pipe or fittings. They may be located by examining the inside of the female ends.

Supports: Horizontal runs of vent must be supported every 3 feet. Wall straps are available for this purpose.

Pipe Sealing: If Simpson Dura-Vent pipe is used, the pipe must be sealed as follows: seal both the inner and outer pipes with a high temperature silicone sealant rated for at least 600°F (commonly known as "RTV"). Run a 1/8" bead of silicone around outside of male end of outer sleeve. Run a 1/8" bead of silicone about 1/4" from the end of the male inner pipe, which is found in the pipe to be attached above. Twist-lock the pipes or fittings together.

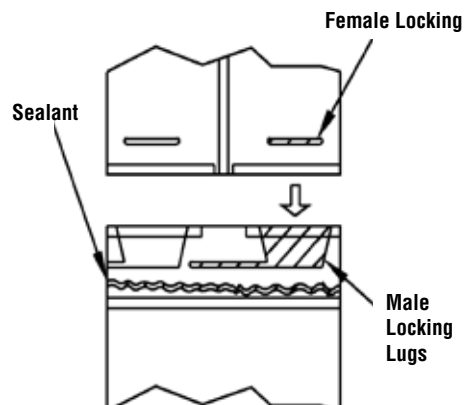

Figure 19

* Other approved chimney brand is Simpson Dura-Vent DV-GS.

Vent Parts List

Direct vent pipe Security™ Secure Vent™* may be used with the Vintage™ gas stove. Please see the lists below to verify the components available from each direct vent pipe manufacturer. Snorkel terminations are available for applications which may require vertical rise on the building exterior. The components listed below come in a galvanized finish. Most of the components are also available in a painted black finish. Add a “B” to the end of the part number when ordering if a black part is desired.

Security™ Secure Vent 6-5/8”x 4” Pipe

<u>Part Number</u>	<u>Description</u>
SV4LC	6” Pipe Length
SV4L12	12” Pipe Length
SV4L24	24” Pipe Length
SV4L36	36” Pipe Length
SV4L48	48” Pipe Length
SV4LA	6” Pipe, Adjustable
SV4LA12	12” Pipe, Adjustable
SV4FA	Flashing, 1/12 to 6/12 Roof Pitch
SV4FB	Flashing, 7/12 to 12/12 Roof Pitch
SV4RSM	Wall Radiation Shield
SV4E46	45° Elbow
SV4E90	90° Elbow
SV4VS	Vinyl Shield Protector
SV4FC	Storm Collar
SV4CGV	Vertical Termination Cap
SV4BF	Firestop
SV4CHC	Horizontal Termination Cap
SV4STC36	Snorkel Termination Cap (36”)
SV4STC14	Snorkel Termination Cap (14”)
SV4BM	Wall Band

Simpson Dura-Vent GS 6-5/8”x 4” Pipe

<u>Part Number</u>	<u>Description</u>
908	6” Pipe Length
907	9” Pipe Length
906	12” Pipe Length
904	24” Pipe Length
903	36” Pipe Length
902	48” Pipe Length
911	11” to 14-5/8” Pipe, Adjustable
942	Wall Thimble
940	Rnd Support Box/Wall Thimble Cover
941	Cathedral Ceiling Support Box
943	Flashing, 0/12 to 6/12 Roof Pitch
943S	Flashing, 7/12 to 12/12 Roof Pitch
945	45° Elbow
990	90° Elbow
950	Vinyl Siding Standoff
953	Storm Collar
963	Ceiling Firestop
988	Wall Strap
981	Snorkel Termination (36”)
982	Snorkel Termination (14”)
984	Horizontal Termination Cap
985	Horizontal Termination Cap (High Wind)
980	Vertical Termination Cap
991	Vertical Termination Cap (High Wind)

Horizontal Vent Installation

Venting terminals may not be recessed into a wall or siding.

1. Set the unit in the desired location. Check whether or not wall studs are in the way when the venting system is attached. If wall studs are in the way, you may want to adjust the location of the unit.
2. Any stove that is horizontally terminated and has a vertical section of pipe off the top of the stove, that first section of pipe must be a minimum of 18” long.
3. All horizontally terminated vent installations may only use 6-5/8”x 4” Security™ Secure Vent pipe*.
4. Assemble the desired combination of pipe and elbow(s) to the appliance adapter with pipe seams facing down. Offsetting the pipe seams as double seams in one place will cause the outer pipe to take an oval shape.
5. When this pipe passes through a wall, a wall thimble - Simpson #942 or Security™ #SV4RSM - is required. The hole in the wall for the wall thimble should be 9-1/4”x 10-1/4”. If the wall being penetrated is constructed of non-combustible material (i.e. masonry block or concrete), a 7” diameter hole is acceptable and a wall thimble is not required.
6. Horizontal runs of vent pipe must be supported every 3 feet. Wall straps - Simpson #988 or Security™ #SV4BM - are available for this purpose.
7. If the vent passes through a ceiling or floor, a firestop - Simpson #963 or Security™ #SV4BF - is required.
8. Also note that venting terminals shall not be recessed into a wall or siding. If installing the termination cap on a wall covered with vinyl siding, a vinyl siding standoff - Simpson #950 or Security™ #SV4VS - or furring strips must be used to ensure that the termination cap is not recessed into the siding.
9. The horizontal run of vent should have a 1/4” rise for every 12” of run toward the termination. Never allow the vent to run downward. This could cause high temperatures and may present the possibility of a fire.
10. If the wall being penetrated is constructed of noncombustible material, such as masonry block or concrete, an 7” diameter hole is acceptable and a wall thimble is not required..
11. The location of the horizontal vent termination on an exterior wall must meet all local and national building codes and must not be blocked or obstructed. For allowable external vent termination locations (see **Page 15**).
12. Allowable clearances from the vent pipe to combustible materials must be maintained. See **Page 6** for these clearances.
13. Do not locate the termination cap where it may be blocked by shrubbery or snow.

* Other approved chimney brand is Simpson Dura-Vent DV-GS.

Snorkel Terminations

For installations requiring a vertical rise on the exterior of the building, 14-inch and 36-inch tall snorkel terminations are available. When using a snorkel, the stove can be vented directly out the back. There is a vent starter collar fastened to the stove (to vent straight out the back), remove the four screws securing the collar, rotate the collar 180 degrees and refasten using the same four screws. Make sure the gasket between the collar and the stove is properly positioned before refastening the collar. After rotating the collar, it will be positioned horizontally. When this pipe passes through a wall, a wall thimble - Simpson part number 942 or Security™ part number SV4RSM is required. The hole in the wall for the wall thimble should be 9-1/4" wide by 10-1/4" high. To vent out the rear wall, add up to a 12" section of pipe and then the snorkel. When the stove is located in a corner of the room, to vent horizontally first add a 45 degree elbow, then up to a 12" section of pipe and lastly the snorkel. Installations using a snorkel have no restrictor installed in the pipe (see **Pages 13 and 14** for restrictor positioning). Follow the same installation procedures as used for standard horizontal terminations. If the snorkel termination must be installed below grade, (i. e. basement application), proper drainage must be provided to prevent water from entering the snorkel. Do not attempt to enclose the snorkel within the wall, or any other type of enclosure. On vinyl siding, furring strips may be used to ensure that the snorkel is not recessed into the siding.

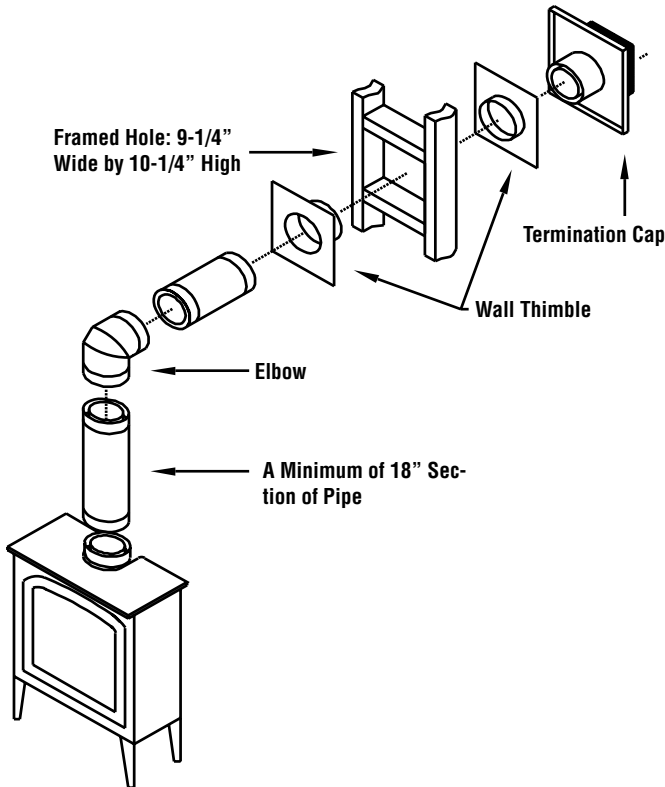

Figure 20

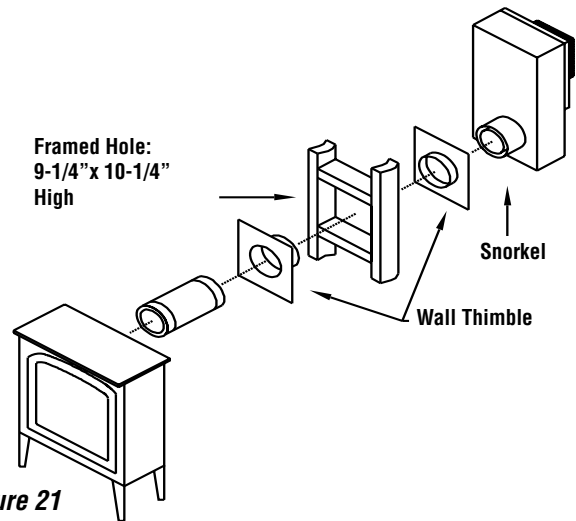

Figure 21

Vertical Vent Installation

Important Notes

1. All vertically terminated vent installations use 6-5/8" x 4" Security™ Secure Vent™ pipe*.
2. If the vent passes through a ceiling or floor, a firestop - Simpson #963 or Security™ #SV4BF - is required.
3. If the vent passes through the roof, a roof flashing - Simpson #943 or 943S or Security™ #SV4FA or SV4FB - and storm collar - Simpson #953 or Security™ #SV4FC - are required.
4. A 1-inch clearance from the vent pipe to combustible materials must be maintained.
5. A maximum of either two 45° elbows or two 90° elbows may be used. See diagrams showing allowable offsets.
6. The maximum system height is 30 feet and the minimum is 10 feet.

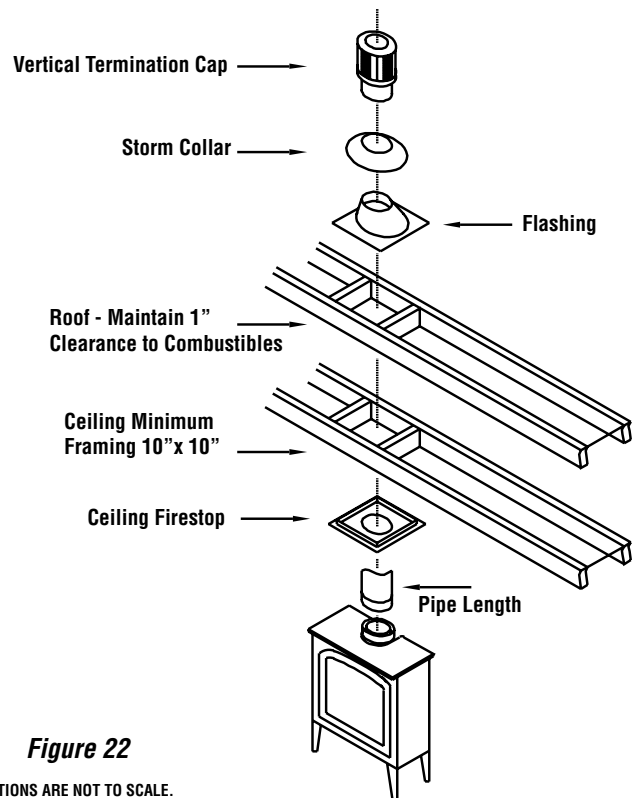

Figure 22

NOTE: DIAGRAMS & ILLUSTRATIONS ARE NOT TO SCALE.

Flue Restrictors

The flue restrictor settings shown in *Figures 26 and 27* are for typical installations and may need to be adjusted from standard to take into account other variables in the installation to achieve proper combustion. See *Flue Restrictor Guidelines* on this page to assist you in making a proper flue restrictor adjustment.

The Vintage™ gas stove uses balanced flue technology to ensure proper combustion. A flue restrictor may need to be installed depending on the vent configuration of your stove. The drawings on *Page 14* show all the allowable pipe configurations for the Vintage gas stove. To properly install the flue restrictor, find your pipe configuration in the drawings on *Page 14* and note which restrictor setting is recommended. The flue restrictor and two black self-tapping 5/32" allen head screws can be found in the firebox in a plastic bag. The restrictor should be placed over the flue opening on the ceiling of the firebox. On the restrictor, two self-tapping 5/32" allen head screws should be installed in either holes 1, 2, 3, or 4 in the restrictor and screwed into the two holes in the firebox ceiling. See the drawing to the right for the location of hole numbers on the restrictor. The numbered holes in which the screws are inserted in the restrictor should correspond to the restrictor position numbers found on the drawings for your pipe configuration. Restrictor positions are based on tests run in a laboratory. The optimum restrictor positions may need to be adjusted slightly depending on the conditions surrounding the residential installation. Do not adjust restrictors to a point where the fireplace is sooting.

Notes: *The higher the number of the flue restrictor position, the greater amount of combustion air will be delivered.*

Flue Restrictor Adjustment Guidelines

After the flue restrictors have been set to the standard settings as shown in *Figures 26 and 27*, the burner flame appearance should be evaluated to determine if the flue restrictors need to be set to a different position to adjust for variables in your installation. Light the appliance and allow it to burn for 20 minutes. See *Flame Color and Behavior* on *Page 18* to determine if you have a proper burner flame appearance. If the proper flame appearance cannot be achieved, the flue restrictor may need to be set to a different position. See the following guidelines to determine if you need to readjust the flue restrictors.

Before proceeding, confirm the manifold and inlet gas pressure is correct, primary air shutter is properly adjusted, venting system connections are secure and not blocked and if you are at a high elevation, ensure unit has been properly derated:

Symptoms - Lack of Combustion Air

If the symptoms listed below are present, you may need to adjust the flue restrictor to a more open position.

- Flame appears yellow
- Floating Flames (lazy, ill defined, quiet, may roll)
- Sooting
- Pilot becomes yellow and appliance shuts down

Symptoms - Excessive Combustion Air

If the symptoms listed below are present, you may need to adjust the flue restrictor to a more closed position.

- Low Flame
- Pilot pulls and appliance shuts down
- Pilot flame ghosts

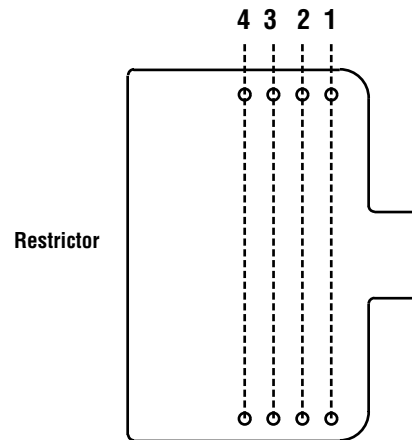

Figure 23

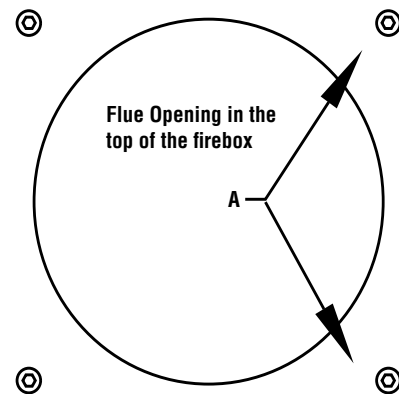

Figure 24

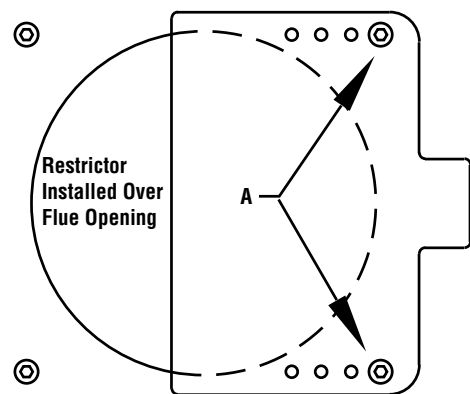

Figure 25

Horizontal Terminations

The shaded areas in the diagram below show all allowable combinations of vent configurations with horizontal terminations. Horizontal sections of pipe require 1/4" of rise for every 12" of run. A second 90 degree or 45 degree elbow (in addition to the first 90 degree elbow at the top of the vertical length of pipe) is allowed as long as the overall length of the horizontal run of pipe does not exceed those shown below. Use the restrictor positions indicated. Note that if the termination cap falls in the unshaded area below then no restrictor is installed in the stove.

To install the stove with pipe directly out the back (as shown in **Figure 21**), a snorkel is required for the Vintage™ gas stove. See **Page 12** for snorkel installation instructions.

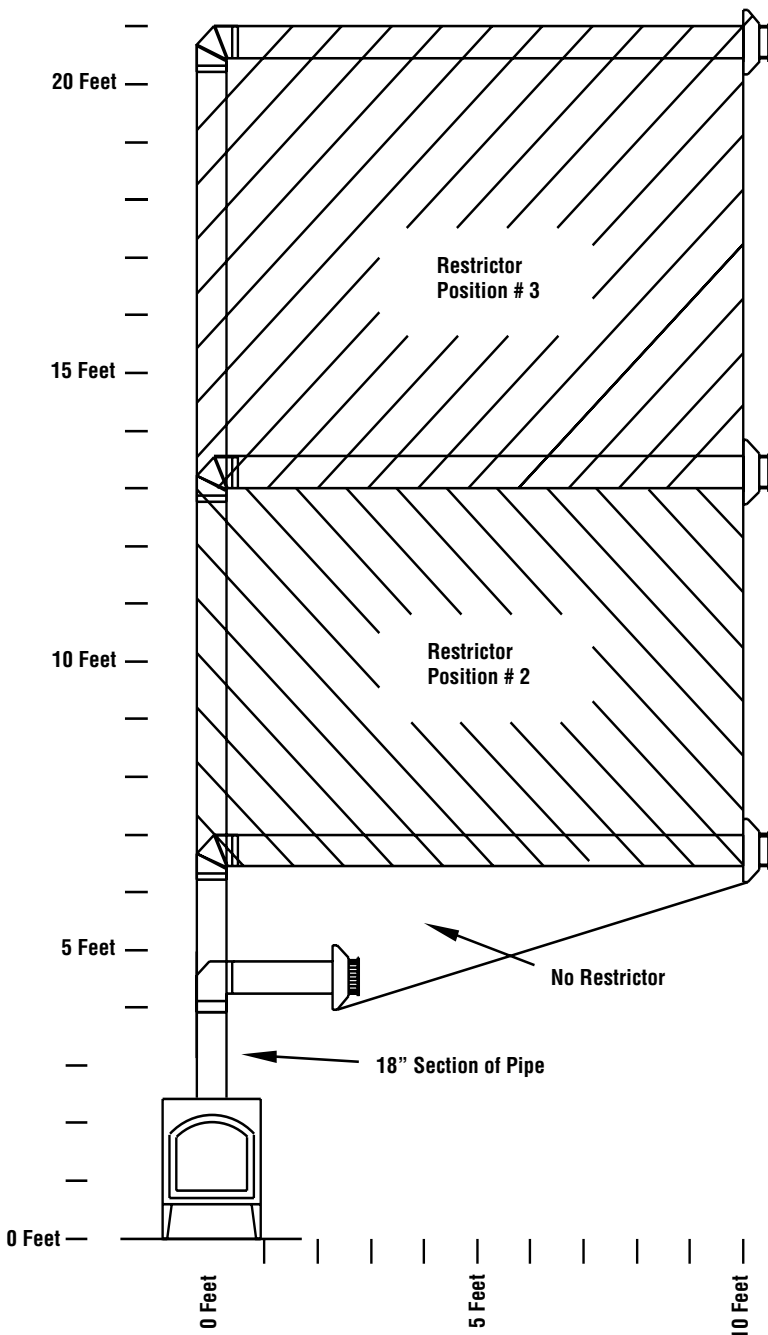

Figure 26

Vertical Terminations

The diagram below shows all allowable combinations of straight vertical and offset to vertical vent configurations with vertical terminations. The termination must fall within the shaded areas on the diagram. Use the indicated restrictor positions. Offsets may consist of two 90 degree elbows OR four 45 degree elbows. The minimum termination height is 10' and the maximum is 30 feet.

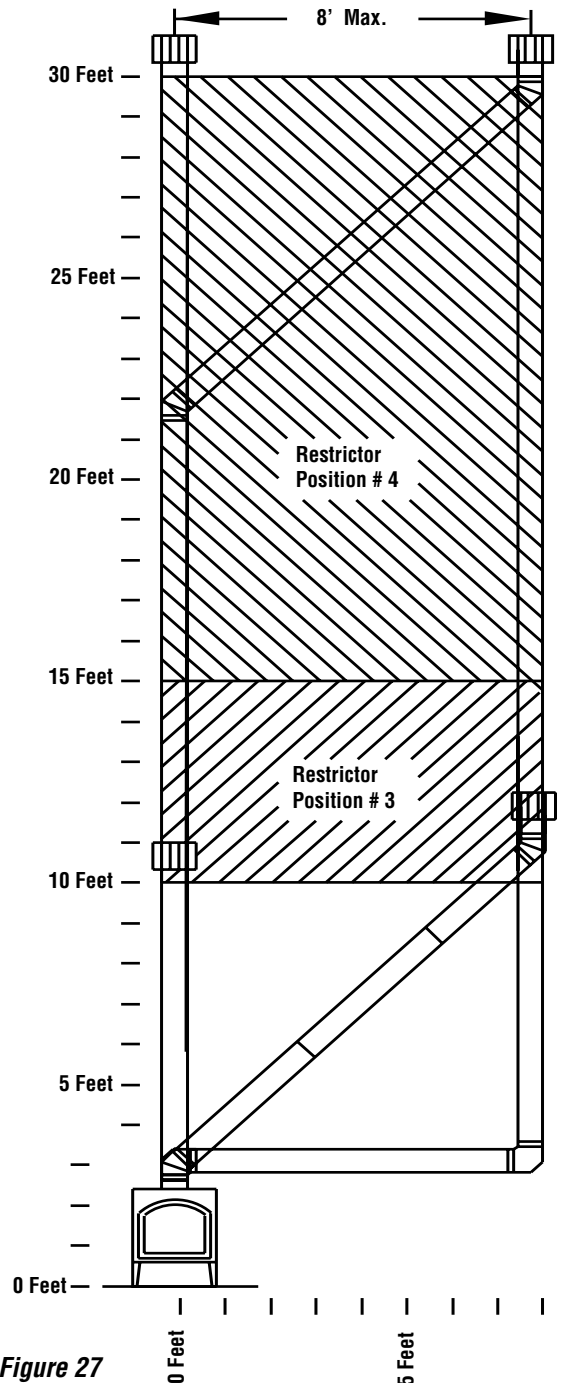
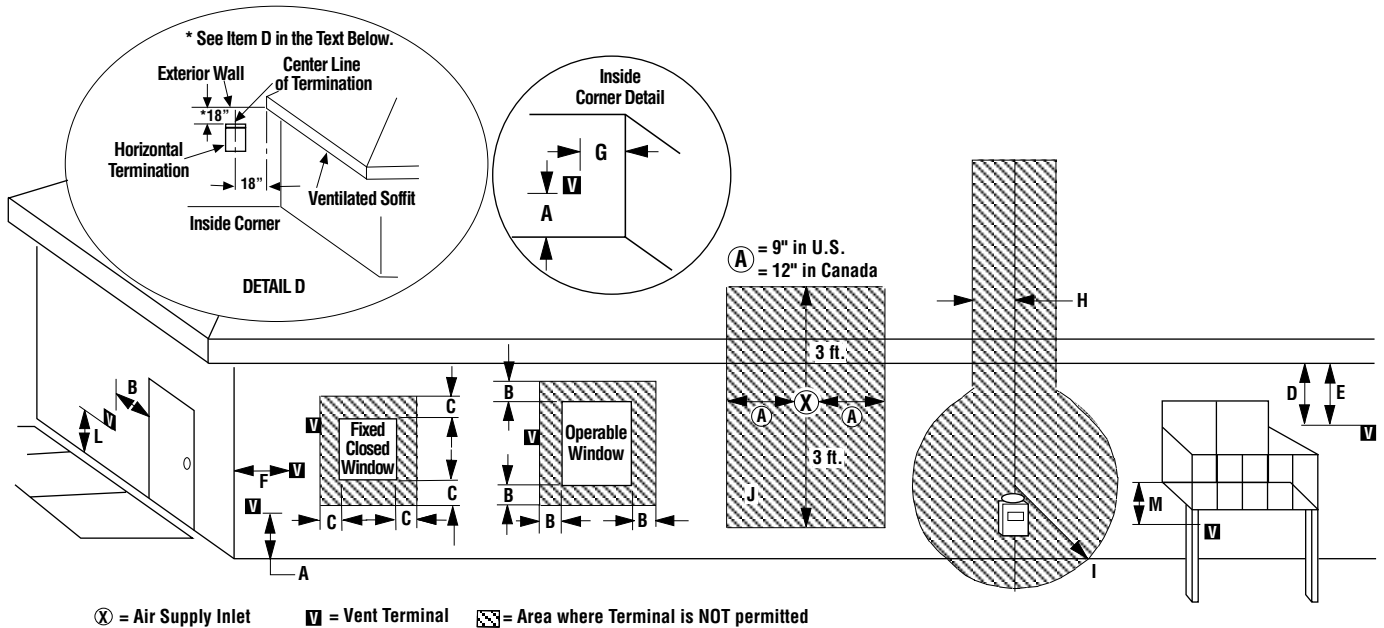

Figure 27

NOTE: DIAGRAMS & ILLUSTRATIONS ARE NOT TO SCALE.

Exterior Horizontal Vent Termination Clearance Requirements



Minimum Clearances	Canadian Installation *	US Installation **
A = Clearance above grade, veranda, porch, deck or balcony.	12 inches (30 cm) *	12 inches (30 cm) **
B = Clearance to window or door that may be opened.	6 in. (15.2 cm) for appliances < 10,000 BTU/hr (3kW), 12 in. (30 cm) for appliances > 10,000 BTU/hr (3kW) and < 100,000 BTU/hr (30kW), 36 inches (91 cm) for appliances > 100,000 BTU/hr (30kW)*	6 in. (15.2 cm) for appliances < 10,000 BTU/hr (3kW), 9 in. (23 cm) for appliances > 10,000 BTU/hr (3kW) and < 50,000 BTU/hr (15kW), 12 inches (30 cm) for appliances > 50,000 BTU/hr (15kW)*
C = Clearance to permanently closed window	12 inches (305 mm) recommended to prevent window condensation	9 inches (229 mm) recommended to prevent window condensation
D = Vertical clearance to ventilated soffit located above the terminal within a horizontal distance of 18 in. (458 mm) from the center line of the terminal	18 inches (458 mm)	18 inches (458 mm)
E = Clearance to unventilated soffit	12 inches (30 cm)	12 inches (30 cm)
F = Clearance to outside corner	5 inches (12.7 cm)	5 inches (12.7 cm)
G = Clearance to inside corner	6 in. (15 cm)	6 in. (15 cm)
H = Clearance to each inside of center line extended above meter / regulator assembly	3 feet (91 cm) within a height of 15 feet above the meter / regulator assembly *	3 feet (91 cm) within a height of 15 feet above the meter / regulator assembly **
I = Clearance to service regulator vent outlet	3 feet (91 cm) *	3 feet (91 cm) **
J = Clearance to non-mechanical air supply inlet to building or the combustion air inlet to any other appliance	6 in. (15.2 cm) for appliances < 10,000 BTU/hr (3kW), 12 in. (30 cm) for appliances > 10,000 BTU/hr (3kW) and < 100,000 BTU/hr (30kW), 36 inches (91 cm) for appliances > 100,000 BTU/hr (30kW)*	6 in. (15.2 cm) for appliances < 10,000 BTU/hr (3kW), 9 in. (23 cm) for appliances > 10,000 BTU/hr (3kW) and < 50,000 BTU/hr (15kW), 12 inches (30 cm) for appliances > 50,000 BTU/hr (15kW)*
K = Clearance to mechanical air supply inlet	6 feet (1.8 meters) *	3 feet (91 cm) above, if within 10 feet (3 m) horizontally**
L = Clearance above paved sidewalk or paved driveway located on public property	7 feet (2.13 m) ‡	7 feet (2.13 m) ‡
M = Clearance under veranda, porch, deck or balcony	12 in. (30 cm) * ‡	12 in. (30 cm) ** ‡

* In accordance with the current CSA-B149.1 National Gas and B149.2 Propane Installation Code - Latest Editions.

** In accordance with the current ANSI Z223.1 / NFPA 54 National Fuel Codes - Latest Edition.

‡ A vent shall not terminate directly above a sidewalk or paved driveway which is located between two single family dwellings and serves both dwellings.

*‡ Only permitted if veranda, porch, deck or balcony is fully open on a minimum 2 sides beneath the floor.

Figure 28

Gas Line Installation

This stove must be connected to the gas line in accordance with local codes and/or the National Fuel Gas Code, ANSI Z223.1 (In Canada, the current CAN/CSA B149.1 installation code).

The gas line screws into the gas valve at the back of the stove 5" in from the right side of the stove and 4 3/16" up from the base of the unit. After connecting the gas line, all joints in the line and connections at the valve should be checked for leaks. After connecting the gas line, all joints in the line and connections at the valve should be checked for leaks before final positioning of the unit. Conduct a gas leakage test of the appliance piping and control system downstream of the shutoff valve in the supply line to the appliance.

Gas Pressure Requirements

A MAJOR CAUSE OF OPERATING PROBLEMS WITH GAS APPLIANCES IS IMPROPER GAS PRESSURE!

The most important item to check during the initial installation and the first thing to check when operating problems occur is gas pressure! This appliance will not function properly unless the required gas pressure is supplied. See the table on this page for gas pressure requirements.

Two pressure taps are provided on the stove's valve to check gas pressures. To access the taps remove the two socket head screws to remove the valve control panel. The taps are located above the on/off/pilot knob (see the diagram on **Page 20**). The right tap is the inlet (supply) pressure side. To check inlet pressure (with the stove burning) insert a small flat bladed screw driver into the tap and turn a half turn counter-clockwise. Cover the tap with the line from a manometer. Read the pressure. Close tap gently but securely after completing the check. The manifold (outlet) tap is to the left of the inlet tap. To check manifold pressure (with the stove burning at the high burn setting) insert a small flat bladed screwdriver into the tap and turn a half turn counter-clockwise. Cover the tap with the line from the manometer and check the pressure. Again close tap gently but securely after completing the check. Check the taps for gas leaks with a gas leak test solution (retighten if necessary).

If the pressure is not sufficient, make sure the gas supply line is large enough, The supply regulator is properly adjusted and the total gas load for the residence does not exceed the amount supplied.

The appliance and its individual shut off valve must be disconnected from the gas supply piping system during any pressure testing of that system at test pressures in excess of 1/2 psig.

The appliance must be isolated from the gas supply piping system by closing its individual manual shut-off valve during any pressure testing of the gas supply piping system at test pressures equal to or less than 1/2 psig. Check with your gas supplier or plumber.

Fuel Type	Inlet Pressure			Manifold Pressure	
	Desired	Minimum	Maximum	On Hi Fire	On Lo Fire
Natural Gas	7" WC	5" WC	10.5" WC	3.5" WC	1.8" WC
LP Gas	11" WC	11" WC	13" WC	10" WC	6.0" WC

LP and Natural Gas Supplies:

Your Vintage™ gas stove is equipped from the factory for use with natural gas only as specified on the Safety / Listing label attached to the appliance. This appliance can only be operated using propane gas (LP) if a certified fuel conversion kit provided by Lennox Hearth Products is installed by a qualified service technician.

Also check the orifice size on the label on the igniter bracket. It must be the correct size for the fuel and altitude.

Do not run propane tank dry. Running the tank dry may cause a hazardous condition due to pressure drop in empty tank.

Solid fuel is NOT to be used with this unit.

Operating Instructions

Pre-Lighting Checklist

Be sure to check these items before the initial lighting of the stove:

- The stove gas label corresponds to the gas supply available - that is "natural gas" for natural gas or "LP gas" for LP gas.
- Gas pressure has been checked carefully - see **Page 16**.
- All gas fittings have been checked for leaks.
- All clearances to combustibles have been met - see **Pages 6 and 7**.
- All combustible materials have been removed from area in front of the stove.
- All vented areas of the stove are unobstructed.
- House is ventilated to clear initial paint curing odors - see **Page 19**.
- All packaging materials have been removed from the fire-box.
- Log set and embers have been installed.
- The glass door is in place and is properly sealed.

Lighting Instructions

The following is a copy of the operating and lighting instructions found with each stove:

FOR YOUR SAFETY READ BEFORE OPERATING

WARNING: IF YOU DO NOT FOLLOW THESE INSTRUCTIONS EXACTLY, A FIRE OR EXPLOSION MAY RESULT CAUSING PROPERTY DAMAGE, INJURY, OR LOSS OF LIFE.

CAUTION: HOT WHILE IN OPERATION. DO NOT TOUCH. KEEP CHILDREN, FURNITURE, GASOLINE AND OTHER LIQUIDS WITH FLAMMABLE VAPORS AWAY. NEVER OPERATE UNIT WITH GLASS OFF OR ATTEMPT TO REMOVE THE GLASS WHILE HOT.

- A. This appliance is equipped with a piezo ignition device to light the pilot. When lighting the pilot, follow these instructions exactly.
- B. **BEFORE LIGHTING**, smell around the appliance area for gas. Be sure to smell next to the floor, because some gas is heavier than air and will settle on the floor.

WHAT TO DO IF YOU SMELL GAS:





DO NOT try to light the appliance.
DO NOT touch any electric switch,
DO NOT use any phone in the building. Immediately call your gas supplier from a neighbor's phone. Follow the gas supplier's instructions. If you cannot reach your gas supplier, call the fire department.

- C. Use only your hand to push in or turn the gas control knob. Never use any tool. If the knob will not push in or turn by hand, don't try to repair it, call a qualified service technician. Force or attempted repair may result in a fire or explosion.
- D. **DO NOT** use this appliance if any part has been under water. Immediately call a qualified service technician to inspect the appliance and to replace any part of the control system and any gas control which has been under water.

OPERATING INSTRUCTIONS

CAUTION: YOUR Lennox Hearth Products gas APPLIANCE MUST ALWAYS BE OPERATED WITH GLASS IN PLACE.

STOP!! Read the safety information above before proceeding.

1. Make sure gas supply shut-off cocks are open and ON/OFF rocker switch is "OFF." If equipped with a thermostat, set it to the lowest setting.
2. Turn off all electrical power to the appliance.
3. Push in gas cock dial slightly and turn clockwise  to "OFF."
NOTE: Dial cannot be turned from "PILOT" to "OFF" unless dial is pushed in slightly. Do not force.
4. Wait five minutes to clear out any gas. Then smell for gas, including near the floor. If you smell gas, STOP! Follow "B" above. If you don't smell gas continue.
5. Locate the pilot by looking under the right front log. A blue flame will be seen when the pilot is lit.
6. Turn the gas control knob counter-clockwise  to the "PILOT" position.
7. Push the knob all the way in and hold in that position. Immediately light the pilot by pressing the igniter button several times until pilot is lit. Continue to hold the knob in for about 30 seconds after the pilot is lit. Release knob and it will pop back out. Pilot should remain lit. If it goes out, repeat steps 4-8 holding knob in an additional 15 seconds after pilot is lit. If knob does not pop out when released, stop and immediately call your service technician or gas supplier. If the pilot will not stay lit after several tries, turn the gas control knob to "OFF" and call your service technician or your gas supplier.
8. After pilot is lit, turn gas control knob counter-clockwise  to "ON." Knob can only be turned to "ON" if the knob has popped out.
9. To turn burner on, turn "ON/OFF" rocker switch to "ON" or set the thermostat to the desired temperature above room temperature.
10. Adjust the flame height (and heat output) by turning the flame height knob clockwise  for full flame and counter-clockwise  for reduced flame.
11. (If you have the optional blower) Turn on the electric power to the appliance and set the blower to the desired air flow after it turns on when the appliance reaches operating temperature.

TO TURN OFF GAS TO APPLIANCE

1. Turn off the "ON/OFF" rocker switch and/or thermostat (if installed) to its lowest setting.
2. Turn off electric power to the appliance if service is to be performed.
3. Push in gas control knob slightly and turn clockwise  to "OFF." Do not force.

This appliance needs fresh air for safe operation and must be installed so there are provisions for adequate combustion and ventilation air.

SHUTDOWN PROCEDURE

To turn off the burner, turn the rocker switch to "OFF" or adjust the thermostat (if installed) to a setting below room temperature. The pilot will remain lit for future burner ignition. For complete shutdown, see "TO TURN OFF GAS TO APPLIANCE" above.

⚠ WARNINGS

- **Improper installation, adjustment, alteration, service or maintenance can cause injury or property damage. For assistance or additional information, consult a qualified installer, service agency or your gas supplier.**
- **Operation of this appliance when not connected to a properly installed and maintained venting system can result in carbon monoxide (CO) poisoning and possible death.**
- **Carbon monoxide poisoning – early signs of carbon monoxide poisoning resemble the flu with headaches, dizziness, or nausea. If you have these signs, get fresh air at once! Have the heater inspected by a qualified service technician. Some people are more affected by carbon monoxide than others. These include pregnant women, people with heart or lung disease or anemia, those under the influence of alcohol and those at high altitudes.**

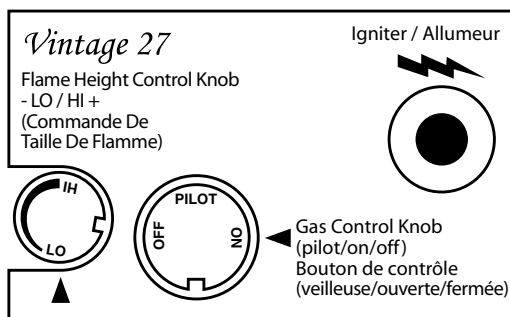

Figure 29

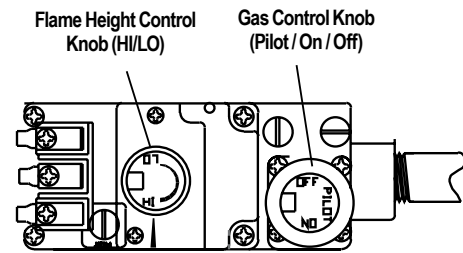

Figure 30

SIT Millivolt Gas Valve

Flame Color and Behavior

Your Vintage™ gas stove is designed for maximum heating efficiency. Therefore, upon lighting of the main burner the flames will be semi-transparent or "bluish." After 10-20 minutes of operation the logs will heat up and the flames will become a yellow/orange color.

Adjusting the stove to cause the flames to turn orange sooner may result in poor combustion, sooting and a hazardous situation. See **Figure 31** showing proper flame appearance.

When testing for proper operation - If an optional thermostat is installed adjust it to its highest temperature setting. Visually determine that main burner gas is burning properly: i.e., no floating, lifting or flashback. Adjust the primary air shutter(s) as required. Check for proper main burner operation at both high and low flame.

Burner Flame Appearance

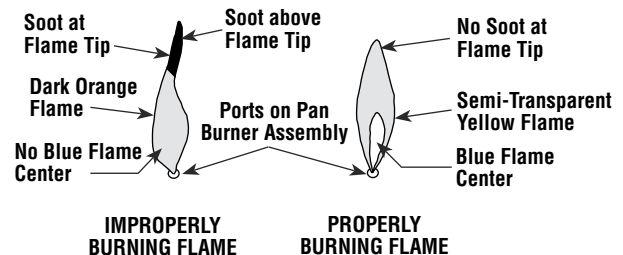

Figure 31

Pilot Flame Appearance

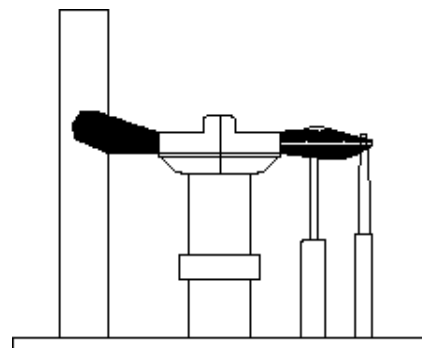

Figure 32

NOTE: DIAGRAMS & ILLUSTRATIONS ARE NOT TO SCALE.

Air Shutter Adjustment

The air shutter control lever is located on the bottom of the stove directly to the left of the gas valve. The lever is linked to the primary air shutter on the main burner. The air shutter regulates the amount of primary air the burner receives and therefore how clean the stove burns. The air shutter should only be adjusted by a qualified gas technician. The stove should burn for about 15 minutes with the logs installed before adjusting the air shutter. Moving the lever down will open the shutter and turn the flames more transparent and blue. Moving the lever up will close the shutter and turn the flames more orange.

CAUTION: The air shutter should never be set so as to make the tips of the flames sooty or create sooting on the viewing glass, logs, or firebox ceiling. If soot begins to form after burning, the air shutter should be opened gradually until the sooting condition stops. Gas quality and gas pressure may vary which can affect the burning characteristics of the stove.

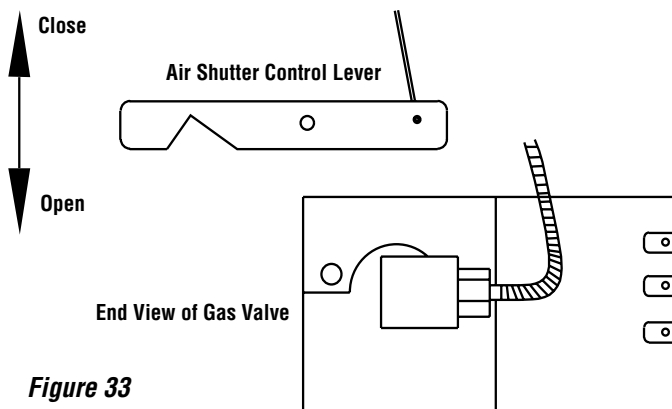
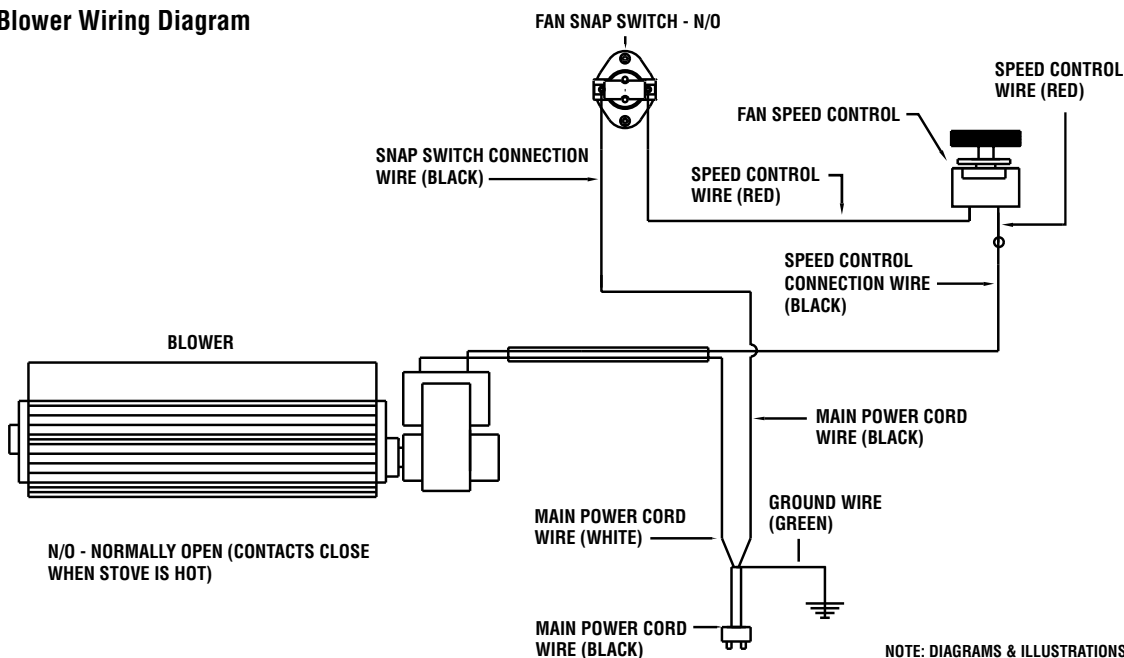

Figure 33

Quiet Operation

As the Vintage™ gas stove is burning, a number of normal operational sounds may be heard. The flow of gas through the gas valve and orifice may make a rushing or whistling noise. If this noise is objectionable, it can be reduced by turning down the flame. Turning down the flame can reduce total heat output by more than 30%.

Optional Blower Wiring Diagram



If the optional blower is installed, the sound of rushing air may be heard when the blower is on. The blower sounds may be reduced by adjusting the speed control located on the blower assembly. Also, a slight clicking sound may be heard as the gas valve or blower switch come on and off.

Paint Curing

This stove has been painted with a high temperature metallic paint. It leaves the factory dry to the touch, but completes the curing process as the stove is used. To cure the paint, burn the appliance four successive times for ten minutes each time with a five minute cool down between each firing. Also some parts of the appliance may be lightly coated with machining oil. Ventilate the house during these first firings as the paint and oil give off carbon dioxide and unpleasant odors. It is recommended that persons sensitive to an imbalance in the indoor air quality avoid the stove during the curing process.

Optional Wall Thermostat

If an optional wall thermostat is to be installed, install the thermostat per the manufacturers instructions (provided with the thermostat). Failure to follow manufacturers instructions could result in a malfunction. Pay special attention to the thermostat location requirements. If the location requirements are not adhered to the appliance, erratic operation or failure may occur.

Do not mount the thermostat where it may be affected by:

- Radiant heat from this appliance, fireplaces, sun or other heat sources.
- Drafts or dead spots behind doors or in corners.
- Hot or cold air from ducts.

Optional Blower

An optional blower (part # 75194) may be installed on your stove to maximize heat distribution. See your Lennox Hearth Products dealer for blower information. The optional blower is equipped with a three-prong (grounding) plug for your protection against shock hazard and should be plugged directly into a properly grounded three-prong receptacle. Do not cut or remove the grounding prong from this plug.

Operating Options

“On-Off” Switch, Thermostat Or Remote Control

Your stove comes equipped with an “On/Off” rocker switch used to turn the burner on and off while the pilot light is on. The switch is a round rocker switch located behind the main control panel door.

A millivolt wall thermostat, or a remote control, can be used to supplement the rocker switch. The gas valve is powered by millivolts generated by the pilot assembly. This millivolt system is very sensitive to electrical resistance, therefore, make sure all connections are tight, clean and free from corrosion. Do not splice any millivolt wires. Consult the table below to determine the proper gage of wire for the thermostat or wall switch connections. This table refers to the total length of the wire (out to the switch and back). The thermostat must be a millivolt type. A 24-volt furnace thermostat will not work. Never hook up household current - 120 Volts - to the millivolt system. It is not recommended to hook up any more than two switches to the stove (for example a rocker switch and a wall thermostat). Additional switches may affect the system resistance and increase the chance of the burner not igniting.

Follow the instructions included with the thermostat or remote control for wiring. The thermostat, remote control and rocker switch will turn the burner on and off independently. Be sure to set the rocker switch to the “Off” position when using the thermostat or remote control and set the thermostat or remote control to the lowest temperature when you wish to use the rocker switch only, otherwise one may override the other.

Millivolt Control System

This stove operates on a millivolt control system. As such, no additional power supply is needed for the stove to heat. The pilot assembly contains a thermocouple that, when heated by the pilot flame, generates electricity (millivolts- $mV=1/1000$ of a volt) which opens a valve allowing gas to continue flowing to the pilot assembly. The pilot assembly also contains a thermopile that, when heated by the pilot flame, generates electricity that flows to terminal #1 (labeled TPTH) on the gas valve. When the electricity is conducted from terminal #1 through the on/off switch, thermostat, or receiver of the remote control to terminal #3 (labeled TH) on the gas valve, the main burner will ignite.

Millivolt Control Schematic

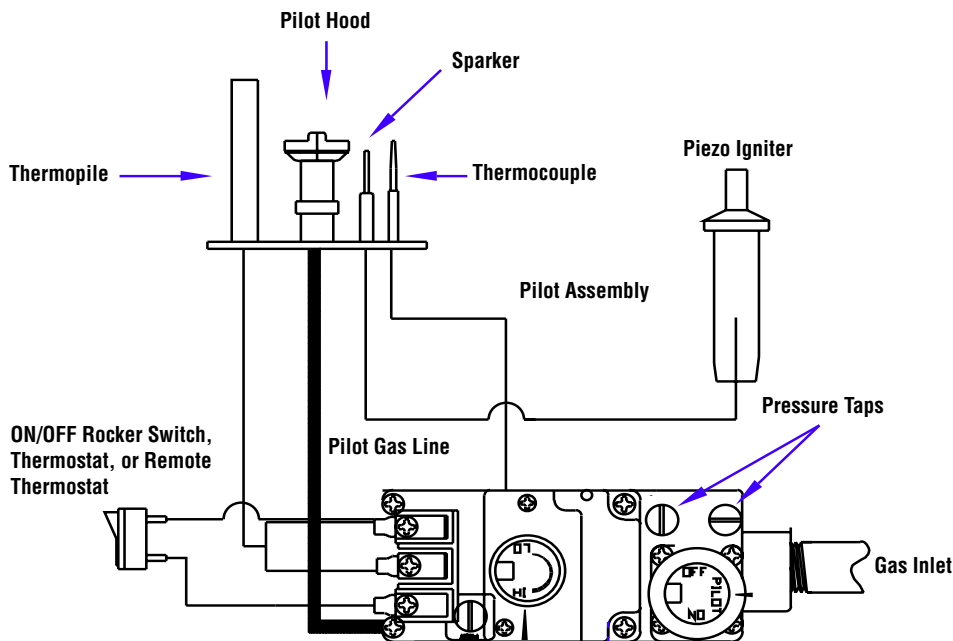

Gas Valve
Wiring Terminals

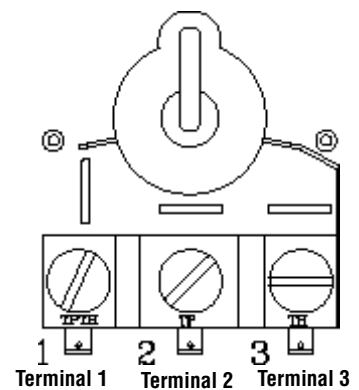

Thermostat Wire	
Wire Size	Maximum Length
12 Gage	100 Feet
14 Gage	64 Feet
16 Gage	40 Feet
18 Gage	25 Feet
20 Gage	16 Feet

CAUTION: Label all wires prior to disconnection when servicing controls. Wiring errors can cause improper and dangerous operation. Verify proper operation after servicing.

Figure 34

MAINTENANCE AND SERVICING

Maintenance Checklist:

The following should only be performed by a qualified service technician.

CAUTION: Label all wires prior to disconnection when servicing controls. Wiring errors can cause improper and dangerous operation. Verify proper operation after servicing.

1. Annual inspection should be made and the following checks performed:

- When unit is cool, open glass viewing door and inspect burner for dirt, soot and lint accumulations and remove if necessary. If excessive soot accumulation is present on burner, have a qualified service technician adjust burner for proper combustion.
- Clean inside of glass viewing door with gas fireplace glass cleaner. NEVER attempt to open door or clean glass when unit is hot.
- Check the hot air outlet vents for lint or other accumulations. Never block or restrict vent openings or obstruct flow of ventilation air.
- Check that direct vent pipe, air intake and flue are open and free of soot, blockage, or debris.
- Check gaskets once a year. Gaskets must be tight. Replace if necessary.
- Inspect the pilot system for proper flame. NEVER ADJUST THE PILOT until after the gas pressure has been checked and supply lines have been completely bled (this may take an hour or more when bleeding through the pilot). All pilots are checked and burned at the factory prior to shipment. The pilot adjustment screw is located to the lower left of the flame height control knob.

Adjust the pilot screw to properly size the flames. The flames should completely surround the thermopile and thermocouple and extend across the main burner tube ports. Be careful not to back the screw out of its threads.

- Check that the area around the stove is kept clear and is free of combustible materials, gasoline and other flammable vapors and liquids.
- Check the millivolt system as per the table on this page.

2. The viewing glass should be cleaned periodically (see Glass Door Cleaning and Maintenance).
3. Should repairs or maintenance of the stove require the disassembly of the vent/air intake system, the reassembly and resealing should be completed by a qualified service technician and follow the instructions on Page 10 of this manual.

Millivolt and System Checks				
Check Test	To Test	Connect Meter Leads to Terminals	Thermostat Connects	Meter Reading Should Be
A	Complete System	2 & 3	Closed	100 MV or More
B	Thermopile Output	1 & 2	Open	Greater Than 325 MV
C	System Resistance	2 & 3	Closed	2.5 Ohms

See Figure 34 - Wiring Terminals

Proper Pilot Flame Appearance

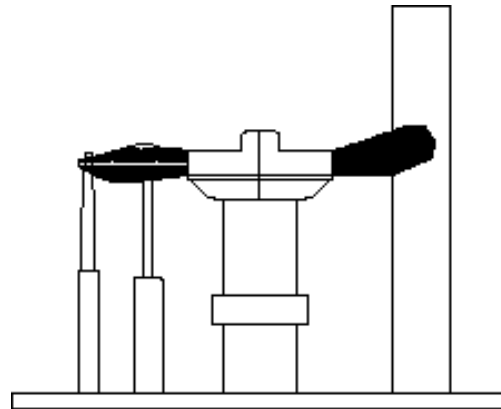

Figure 35

General Vent Pipe Maintenance

Conduct an inspection of the venting system semi-annually. Recommended areas to inspect are as follows:

1. Check areas of the venting system which are exposed to the elements for corrosion. These will appear as rust spots or streaks and in extreme cases, holes. These component should immediately be replaced.
2. Remove the cap and shine a flashlight down the vent. Remove any bird nests or other foreign material.
3. Check for evidence of excessive condensate, such as water droplets forming in the inner liner and subsequently dripping out at joints. Continuous condensate can cause corrosion of caps, pipe and fittings. It may be caused by having excessive lateral runs, too many elbows and exterior portions of the system being exposed to cold weather.
4. Inspect joints to verify that no pipe sections or fittings have been disturbed and consequently loosened. Also check mechanical supports such as wall straps or plumbers' tape for rigidity.

Opening and Removing Glass Door

The doors on the stove may be opened to provide an unobstructed view of the fire or to provide greater access to the firebox. To open the doors, when the stove is cool, simply pull on the right door and it will swing open. The left door can then also be swung open.

CAUTION: Do not open the glass door when the stove is burning. Let the unit cool before opening the door.

Lift off the stove top to access the glass door. At the top of the glass door are two spring-loaded "I" (looped) bolts. Pull each loop forward while rotating at 90 degrees, releasing the top of the glass door. To remove the door, grasp it firmly with both hands and lift it up. The glass door is fragile so it is important to place it in a secure spot until reinstalled. To reinstall the door, the bottom of the door must be inserted in the slot at the bottom of the firebox. The loops on the spring loaded "I" bolts must be pulled forward and down into the receiving bracket on the door to apply pressure against the door. The latches need pulled forward and rotated at 90 degrees. Once the loops are in the receiving bracket you will then rotate them back 90 degrees so they are at the angle shown in **Figure 36**.

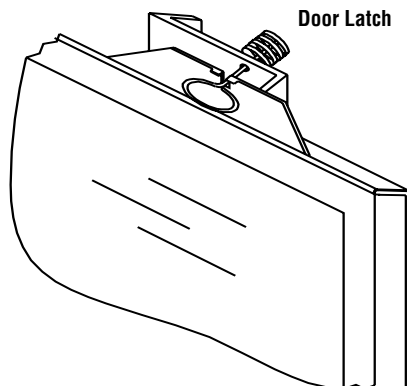

Figure 36

Glass/Door Maintenance

Cleaning: When cooled, the glass may be cleaned with a clean, soft cloth and a household glass cleaner. For cleaning white condensation from the interior glass use a gas stove glass cleaner available from your stove dealer. Use of caustic or abrasive cleaners may damage glass. Gold or nickel plated trim must be cleaned with a household glass cleaner or denatured alcohol and a soft cloth before firing or fingerprints and stains will remain permanently. Never use abrasive polish to clean the gold or nickel as it will ruin the finish. **DO NOT** operate stove with broken glass. **DO NOT** clean door or glass when hot. **DO NOT** abuse glass door by striking or slamming shut. **DO NOT** use substitute materials if replacing glass. **DO NOT** spray commercial glass cleaner with ammonia on the door and glass gasket as it may dissolve the gasket glue.

WARNING: Do not operate appliance with the glass panel removed, cracked, or broken. Do not remove glass door while the stove is hot. Replacement of the glass door should be done by a qualified service technician.

Glass Replacement: Should the glass be damaged, both the glass and the gasket should be replaced. The replacement glass and gasket are available from your Lennox Hearth Products dealer. The glass is neo-ceramic and alternative types must not be used. To install the new glass and gasket: Remove the old glass and gasket. The glass is held in place by two metal tabs located on the sides of the glass door frame. Using a flat-bladed screwdriver or pliers, bend the tabs up to release the old glass from the frame. Should the old glass be broken, care should be used in removing and discarding the glass so as not to injure yourself. Install the new glass and gasket by positioning the frame with the bent lips up and set the glass on the frame. (The glass is square so there is no top or bottom). Slide the glass so the gasket is down against the 1/8" lip. Using pliers, bend the metal tabs firmly down onto the gasket on the glass. The tabs must be bent into the gasket to ensure a tight seal of the glass to the stove. Install the glass frame on the stove. See instructions on this page for removing and replacing the glass door.

TROUBLESHOOTING

NOTE: When troubleshooting the gas control system, be sure the external gas shut off valve, located at the gas supply inlet is in the “ON” position.

IMPORTANT: Call your gas supplier or plumber for additional help with any gas control problem. Valve system troubleshooting should only be accomplished by a qualified service technician.

SYMPTOM	PROBABLE CAUSE	CORRECTIVE ACTION
Thin black coating (soot) forms on the viewing glass, logs, or firebox.	Improper log or ember placement. Blocked flue. Improper air shutter setting.	See Log Set and Ember Installation . Check for obstructions in vent pipe, check for proper restrictor setting. See Flue Restrictors . See Air Shutter Adjustment .
Humming or whistling coming from fireplace.	Normal operating noise. Dirt in burner orifice.	See Quiet Operation . The noise may be reduced by slightly turning the flame down. Turning the flame down will reduce the heat output of the fireplace. Clean orifice.
A change in flame appearance or burner operation.	A change in gas pressure. Improper ember or log placement.	Have your gas supplier check for correct gas pressure (7" W.C. natural gas; 11" W.C. LP gas). See Log Set and Ember Installation .
Pilot will not light.	No gas supplied to unit. Air in line. Defective igniter (no spark at electrode). The valve control knob is not turned to “pilot” and pushed in.	Turn on gas. To purge, hold in control knob in pilot position for 1-2 minutes and light. Check for spark at electrode and pilot, if no spark and electrode wire is properly connected, replace igniter. See Lighting Instructions .
Pilot will not stay lit after carefully following lighting instructions.	Pilot flame is not surrounding thermocouple. Thermocouple not generating sufficient voltage. Air in gas supply line.	Check pilot flame adjustment (see Maintenance and Servicing section). Check the connection between the thermocouple lead and the valve. Turn control knob to “pilot” and push in and light pilot. While lit, take millivolt reading at lead going into valve’s CPU. Minimum reading should be 17 millivolts. If less, replace thermocouple. Purge air in pilot gas line by holding in control knob at “pilot” and sparking igniter. The air in the line may take up to several minutes to purge.
Main burner will not burn.	Pilot has gone out. Rocker switch or thermostat wires are defective. Thermopile may not be generating sufficient millivolts.	See Lighting Instructions . Disconnect rocker switch and thermostat wires at terminals 1 and 3 on valve. Jumper across from 1 to 3 with pilot lit. If burner comes on either rocker switch or thermostat wiring is not functioning. Make sure thermopile is fully engulfed by the pilot flame. Check thermopile with millivolt meter. With pilot lit and the rocker switch and thermostat off, the millivolt reading with the meter connected to valve terminals 1 and 2 should be after 2 minutes at least 325. If the thermopile lead connections are good at terminals 1 and 2 and readings are less than 325, replace faulty thermopile.

REPLACEMENT PARTS

Vintage™ Model VIN

Part Number	Description
H6031	Cassette Assembly, NG (if LP, also requires 75190 Conversion Kit)
H5936	Burner Assembly
H5947	Pilot Assembly NG
H2830	Pilot Assembly LP
H5942	Gas Control Valve, NG (if LP, also requires H5945 LP Regulator)
H5943	Regulator, NG
H5945	Regulator, LP
H5955	Orifice, Main Burner, #40 NG
H5962	Orifice, Main Burner, LP
H5944	Pilot Orifice NG
75190	Conversion Kit, NG to LP
75191	Conversion Kit, LP to NG
H5877	Blower Speed Control (rheostat)
H5875	Blower Snap Switch
H5744	On/Off Switch
H3108	On/Off Switch Wires
H5745	Piezo Igniter
H5882	Thermopile
H5883	Thermocouple
H5660	Power Cord
H5861	Log Set
H5863	Bag of Embers (volcanic stone)
H5864	Bag of Rockwool (glowing embers)
H5865	Bag of Steel Wool
H3082	Glass Door Assembly
H5518	Flue Restrictor Plate
H5854	Cast Steel Baffle
H5920	45° Pipe Adapter (Simpson Dura-Vent)
H5848	Cast Reversible Side (2 per stove)
H5849	Cast Reversible Top (2 per stove)
H5855	Cast Reversible Trivet
H5850	Cast Stock Trivet (has round holes)
H5845	Cast Stove Top
H5851	Cast Left Door
H5852	Cast Right Door
H5853	Door Hinges (4 per stove)
H5915	Door Hinge Pins (4 per stove)
70K99	Touch-Up Paint Kit, Black

ACCESSORIES

Panel Kits (Required)

Cat. No.	Model	Description
75199	VINT-CPS-B	Cast Iron Panel Set/Black, Reversible ❶
H7406	VINTAGE-PK-BG	Gallo Veneziano Stone Panels

Gas Conversion Kits

Cat. No.	Model	Description
75191	VINT-TETN-CK-LP TO NG	Conversion Kit LP to NG
75190	VINT-TETN-CK-NG TO LP	Conversion Kit NG to LP

❶ The cast iron panels have a different design on each side. They can be flipped to side A or to side B, depending on your taste.



Remote Control (AC)



Remote Control (Deluxe)



Digital Wall Thermostat

Misc.

Cat. No.	Model	Description
75194	VINT-TET BLWR	Blower
75195	VINT-TETN-MHK	Mobile Home Install Kit
75203	VINT-RVTC	Rear Vent Top Cover
70005	RT-AC	Remote Thermostat, Alternating Current
H0251	RCL-STAT	Remote Thermostat, Deluxe (Timer, T-Stat, Clock)
H4635	DWTK	Digital Wall Thermostat Kit

Cast Iron Panel Set/Black, Reversible

Top Panels - Side A



Top Panels - Side B

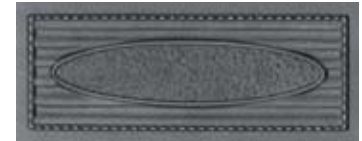

Side Panels - Side A



Side Panels - Side B

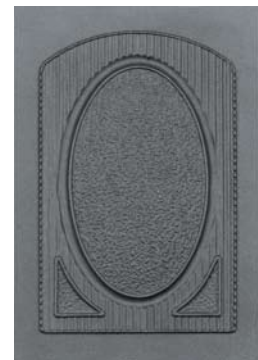

Gallo Veneziano Stone Panel Set



SAFETY / LISTING LABEL

Tested & Listed By **O-T-L** Beaverton Oregon USA
 OMI-Test Laboratories, Inc.
 Report No. / Numéro de Rapport 50-S-11b-5

MODEL / MODÈLE **Vintage™** SERIAL NO. **VIN**

MANUFACTURED BY / FABRIQUÉ PAR:
LENNOX HEARTH PRODUCTS
 PO BOX 987
 AUBURN, WA., USA 98071



HOMOLOGUÉ FOYER RADIANT PRÉFABRIQUÉ AU GAZ - NE PAS UTILISER AVEC DU COMBUSTIBLE SOLIDE

MAY BE INSTALLED IN RESIDENTIAL BEDROOMS AND MANUFACTURED (MOBILE) HOMES.
 TESTÉ SELON LA NORME ANSI Z21.88-2005/CSA 2.33-2005 «FOYER RADIANT AU GAZ», UL307B, CSA P.4.1-02, ET CGA 2.17-M91.
 CET APPAREIL DOIT ÊTRE INSTALLÉ CONFORMÉMENT AUX EXIGENCES DES CODES RÉGIONAUX ET DU CODE D'INSTALLATION ANSI NFPA 54-DERNIÈRE ÉDITION (ÉTATS-UNIS), OU CAN/CSA-B149.1-DERNIÈRE ÉDITION (CANADA) POUR LES MAISON MOBILE LE STANDARD DE SÉCURITÉ EST TITRE 24CFR, PART 3280. CET APPAREIL DOIT ÊTRE INSTALLER SELON LES SPÉCIFICATIONS DU MANUFACTURIER.

CET APPAREIL DOIT ÊTRE UTILISÉ AVEC LE TYPE DE GAZ INDICÉ SUR LA PLAQUE SIGNALÉTIQUE ET PEUT ÊTRE INSTALLÉ DANS UNE MAISON PRÉUSINÉE OU DANS UNE MAISON MOBILE FIXE, LÀ OÙ LES CODES RÉGIONAUX LE PERMETTENT. VOIR LE MANUEL D'ENTRETIEN POUR PLUS DE DÉTAILS. CET APPAREIL NE PEUT PAS ÊTRE CONVERTI POUR L'USAGE AVEC D'AUTRES TYPES DE GAZ À MOINS D'UTILISER UNE TROUSSE DE CONVERSION HOMOLOGUÉE.

DANGER: RISQUE DE CHOC ÉLECTRIQUE. DÉBRANCHEZ L'APPAREIL AVANT D'EN FAIRE L'ENTRETIEN.
 SI L'APPAREIL REQUIERT UN BRANCHEMENT ÉLECTRIQUE, LES RACCORDEMENTS ET LA MISE À LA TERRE DOIVENT ÊTRE CONFORMES AUX EXIGENCES DES CODES RÉGIONAUX ET DU CODE D'INSTALLATION ANSINFPFA 70 OU CSA C22-1.

FACTORY EQUIPPED FOR NATURAL GAS. IF CONTROL PANEL CONTRADICTS THIS LABEL, UNIT FUEL TYPE HAS BEEN CONVERTED. CET APPAREIL EST MUNI D'ÉQUIPEMENT POUR L'USAGE DU GAZ NATUREL. SI L'ÉTIQUETTE DU PANNEAU DES COMMANDES CONTRETDIT CETTE ÉTIQUETTE, C'EST QUE LE TYPE DE CARBURANT DE CET APPAREIL A ÉTÉ CONVERTI.

VENTED GAS FIREPLACE HEATER - NOT FOR USE WITH SOLID FUEL

MAY BE INSTALLED IN RESIDENTIAL BEDROOMS AND MANUFACTURED (MOBILE) HOMES. TESTED TO ANSI Z21.88-2005/CSA 2.33-2005 "VENTED GAS FIREPLACE HEATERS", UL307b, CSA P.4.1-02, AND CGA 2.17-M91.
 THIS APPLIANCE MUST BE INSTALLED IN ACCORDANCE WITH LOCAL CODES, IF ANY. IF NOT, FOLLOW THE CURRENT ANSI Z223.1/NFPA 54-LATEST EDITION (USA) OR CAN/CSA B149.1-LATEST EDITION (CANADA) AND SAFETY STANDARD, TITLE 24 CFR, PART 3280 FOR MOBILE HOMES. ALSO, APPLIANCE MUST BE INSTALLED IN ACCORDANCE WITH THE MANUFACTURER'S INSTALLATION INSTRUCTIONS.

THIS APPLIANCE IS ONLY FOR USE WITH THE TYPE OF GAS INDICATED ON THE RATING PLATE AND MAY BE INSTALLED IN AN AFTERMARKET, PERMANENTLY LOCATED, MANUFACTURED (MOBILE) HOME WHERE NOT PROHIBITED BY LOCAL CODES. SEE OWNER'S MANUAL FOR DETAILS. THIS APPLIANCE IS NOT CONVERTIBLE FOR USE WITH OTHER GASES, UNLESS A CERTIFIED KIT IS USED.

DANGER: RISK OF ELECTRICAL SHOCK. DISCONNECT POWER BEFORE SERVICING UNIT. IF ELECTRICALLY CONNECTED, CONNECTIONS AND GROUNDING MUST BE IN ACCORDANCE WITH LOCAL CODES, IF ANY. IF NOT, FOLLOW THE CURRENT NATIONAL ELECTRICAL CODE ANSINFPFA 70-LATEST EDITION (USA) OR CSA C22-1-LATEST EDITION (CANADA).

Vintage (VIN)		
RATINGS	NATURAL GAS	LP GAS
MAX/MIN INPUT BTUH 0-2,000 FT (0-610 M)*	27,000/19,500	27,000/21,300
MANIFOLD PRESSURE (IN. WC) LOW - HIGH	1.8 - 3.5	6.0 - 10.0
MIN. INLET PRESSURE (IN. WC)	5.0	11.0
ORIFICE (DMS) 0-2,000 FT (0-610 M)*	#40/.098 IN.	#53/.060 IN.

*UNIT FACTORY EQUIPPED FOR 0-2000 FT/0-610 M, IN CANADA 0-4500 FT/0-1370 M
 ELECTRICAL RATING: 120 VAC, 60 HZ, LESS THAN 2 AMPS

VENTING: THIS APPLIANCE MUST BE PROPERLY CONNECTED TO A VENTING SYSTEM IN ACCORDANCE WITH THE MANUFACTURER'S INSTRUCTIONS. SEE MANUFACTURER'S INSTALLATION INSTRUCTIONS FOR APPROVED PIPE BRANDS AND PIPE SEALING PROCEDURES.
 FOR ALTITUDES ABOVE 2,000 FT/610M (IN CANADA 4500 FT/1370M) DE-RATE THE APPLIANCE BY FOUR (4)% FOR EVERY 1,000 FT (405 M).
 THIS VENTED GAS FIREPLACE HEATER IS NOT FOR USE WITH AIR FILTERS.

MINIMUM CLEARANCES TO COMBUSTIBLES IN INCHES / DÉGAGEMENTS AUX COMBUSTIBLES - POUÇES

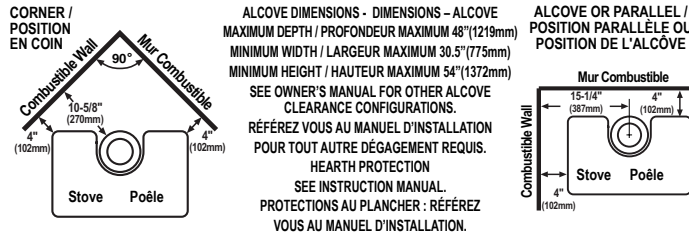

Vintage (VIN)		
SPÉCIFICATIONS	GAZ NATUREL	GAZ PROPANE
ENTRÉE MAX/MIN BTU/HR 0-4500 pi (0-1370 M)*	27000/19500	27000/21300
PRESSION À LA SORTIE (IN. WC/C.E.)	1.8 - 3.5	6.0 - 10.0
PRESSION MINIMUM D'ENTRÉE DU GAZ (IN. WC/C.E.)	5.0	11
ORIFICE (DMS) 0-4500 pi (0-1370 M)*	#40/.098 po.	#53/.060 po.

* L'APPAREIL PRÉUSINÉ EST MUNI D'ÉQUIPEMENT POUR 0-2000 PIEDS (0-610 M), AU CANADA 0-4500 PIEDS (0-1370M). SPÉCIFICATIONS ÉLECTRIQUE: 120 VCA, 60 HZ, MOINS DE 2 AMPÈRES

CONDUIT: CET APPAREIL DOIT ÊTRE INSTALLER SEULEMENT AVEC UN CONDUIT D'ÉVACUATION RECOMMANDÉ PAR LE MANUFACTURIER. TOUJOURS SE RÉFÉRER AU MANUEL D'INSTALLATION.
 EN ALTITUDE, AU-DELÀ DE 2000 PI/610 M, (AU CANADA 0-4500 PI/0-1370M) LA CAPACITÉ ÉNERGÉTIQUE DE L'APPAREIL DIMINUE DE QUATRE (4)% POUR CHAQUE 1000 PI (405 M).
 CE FOYER RADIANT AU GAZ À ÉVACUATION N'EST PAS CONÇU POUR ÊTRE UTILISÉ AVEC DES FILTRES À AIR.

DANGER: CET APPAREIL DÉGAGE DES TEMPÉRATURES ÉLEVÉES ET DEVRAIT ÊTRE INSTALLÉ À L'ÉCART DES ENDOITS TRÈS PASSANTS ET LOIN DES MEUBLES ET RIDEAUX. SURVEILLEZ LES ENFANTS QUI SE TROUVENT DANS LA PIÈCE. GARDEZ LA ZONE AUTOUR DU FOYER EXEMPTÉ DE MATÉRIAUX COMBUSTIBLES, D'ESSENCE ET AUTRES VAPEURS ET LIQUIDES INFLAMMABLES. MAINTENEZ LE BRÛLEUR ET LE BOÎTIER DES COMMANDES PROPRE EN TOUT TEMPS. VOIR LES MANUELS D'INSTALLATION ET D'ENTRETIEN QUI ACCOMPAGNENT L'APPAREIL. SEUL LE PANNEAU VITRÉ FOURNI PAR LE MANUFACTURIER PEUT ÊTRE UTILISÉ AVEC CET APPAREIL. EN AUCUN CAS, L'APPAREIL NE PEUT ÊTRE UTILISÉ SANS LA VITRE OU AVEC LA VITRE BRISÉE. LE REMPLACEMENT DE LA VITRE DOIT ÊTRE EFFECTUÉ PAR UN TECHNICIEN DE SERVICE QUALIFIÉ.

AVERTISSEMENT: UNE INSTALLATION INADÉQUATE DE MÊME QU'UN AJUSTEMENT, UNE MODIFICATION, UNE RÉPARATION OU UN ENTRETIEN INCORRECTS PEUVENT CAUSER DES BLESSURES OU DOMMAGES À LA PROPRIÉTÉ. RÉFÉREZ-VOUS AU MANUEL D'ENTRETIEN LIVRÉ AVEC CET APPAREIL. POUR DE L'ASSISTANCE, CONSULTEZ UN INSTALLATEUR QUALIFIÉ, UNE ENTREPRISE DE SERVICE OU UN FOURNISSEUR DE GAZ.

CAUTION: HOT WHILE IN OPERATION. DO NOT TOUCH. SEVERE BURNS MAY RESULT. KEEP CHILDREN, CLOTHING, FURNITURE, GASOLINE AND OTHER LIQUIDS HAVING FLAMMABLE VAPORS AWAY. KEEP BURNER AND CONTROL COMPARTMENT CLEAN. SEE INSTALLATION AND OPERATING INSTRUCTIONS ACCOMPANYING APPLIANCE. FOR USE WITH GLASS DOORS CERTIFIED WITH THIS APPLIANCE ONLY. DO NOT OPERATE THE APPLIANCE WITH GLASS REMOVED, CRACKED OR BROKEN. REPLACEMENT OF THE PANEL(S) SHOULD BE DONE BY A LICENSED OR QUALIFIED PERSON.

WARNING: IMPROPER INSTALLATION, ADJUSTMENT, ALTERATION, SERVICE OR MAINTENANCE CAN CAUSE INJURY OR PROPERTY DAMAGE. REFER TO THE OWNER'S INFORMATION MANUAL PROVIDED WITH THIS APPLIANCE. FOR ASSISTANCE OR ADDITIONAL INFORMATION CONSULT A QUALIFIED INSTALLER, SERVICE AGENCY OR GAS SUPPLIER.

DATE OF MANUFACTURE / DATE DE FABRICATION

2007	2008	2009	2010	JAN JANV	FEB FEVR	MAR MARS	APR AVR	MAY MAI	JUN JUN	JUL JUIL	AUG AOÛT	SEP SEPT	OCT OCT	NOV NOV	DEC DEC
<input type="checkbox"/>	<input type="checkbox"/>	<input type="checkbox"/>	<input type="checkbox"/>	<input type="checkbox"/>	<input type="checkbox"/>	<input type="checkbox"/>	<input type="checkbox"/>	<input type="checkbox"/>	<input type="checkbox"/>	<input type="checkbox"/>	<input type="checkbox"/>	<input type="checkbox"/>	<input type="checkbox"/>	<input type="checkbox"/>	<input type="checkbox"/>

Part No./ No. Pièce #36224 Rev. A, 05/2007

DO NOT REMOVE OR COVER THIS LABEL

MADE IN U.S.A.

NE PAS RETIRER CETTE ÉTIQUETTE

Fabriqué aux U.S.A.

IGN

LIGHTING LABEL

FOR YOUR SAFETY READ BEFORE OPERATING

WARNING: IF YOU DO NOT FOLLOW THESE INSTRUCTIONS EXACTLY, A FIRE OR EXPLOSION MAY RESULT CAUSING PROPERTY DAMAGE, INJURY OR LOSS OF LIFE.

CAUTION: HOT WHILE IN OPERATION. DO NOT TOUCH. KEEP CHILDREN, FURNITURE, GASOLINE AND OTHER LIQUIDS WITH FLAMMABLE VAPORS AWAY. NEVER OPERATE UNIT WITH GLASS DOOR OFF OR ATTEMPT TO OPEN THE DOOR WHILE HOT.

- This appliance is equipped with a piezo ignition device to light the pilot. When lighting the pilot, follow these instructions exactly.
- BEFORE LIGHTING, smell around the appliance area for gas. Be sure to smell next to the floor because some gas is heavier than air and will settle on the floor.

WHAT TO DO IF YOU SMELL GAS:

- DO NOT try to light the appliance.
 - DO NOT touch any electric switch; do not use any phone in the building.
 - Immediately call your gas supplier from a neighbor's phone. Follow the gas supplier's instructions.
 - If you cannot reach your gas supplier, call the fire department.
- Use only your hand to push in or turn the gas control knob. Never use any tool. If the knob will not push in or turn by hand, don't try to repair it, call a qualified service technician. Force or attempted repair may result in a fire or explosion.
 - DO NOT use this appliance if any part has been under water. Immediately call a qualified service technician to inspect the appliance and to replace any part of the control system and any gas control which has been under water.

OPERATING INSTRUCTIONS

CAUTION: YOUR LENNOX GAS APPLIANCE MUST ALWAYS BE OPERATED WITH GLASS DOOR IN PLACE.

STOP! Read the safety information above before proceeding.

- Open the lower door. Make sure gas supply shut-off cocks are open and ON/OFF Rocker Switch is "OFF". If equipped with a thermostat, set it to the lowest setting.
- Turn off all electrical power to the appliance.
- Push in Gas Control Knob slightly and turn clockwise to "OFF".

NOTE: Knob cannot be turned from "PILOT" to "OFF" unless Knob is pushed in slightly. Do not force.

- Wait five (5) minutes to clear out any gas. If you smell gas, STOP! Follow "B" above. If you don't smell gas continue.
- Locate the pilot by looking at the center bottom of the back log. Blue flame will be seen when the pilot is lit.

- Turn the gas control knob counterclockwise to the "PILOT" position.

- Push the knob all the way in and hold in that position. Immediately light the pilot by pressing the igniter button several times until pilot is lit. Continue to hold the knob in for about 30 seconds after the pilot is lit. Release knob and it will pop back out.

Pilot should remain lit. If it goes out, repeat steps 4-8 holding knob in an additional 15 seconds after pilot is lit.

- If knob does not pop out when released, stop and immediately call your service technician or gas supplier.
- If the pilot will not stay lit after several tries, turn the gas control knob to "OFF" and call your service technician or your gas supplier.

- After pilot is lit, turn gas control counterclockwise to "ON". Knob can only be turned "ON" if the knob has popped out.
- Turn burner on, turn "ON/OFF" rocker switch to "ON" or set the thermostat to the desired temperature above room temperature.
- Adjust the flame height (and heat output) by turning the flame height knob clockwise for reduced flame and counterclockwise for full flame.
- Turn on all electrical power to the appliance.
- Set the blower to the desired air flow after it turns on when the appliance reaches operating temperature.

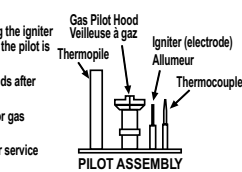
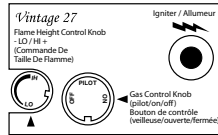

TO TURN OFF GAS TO APPLIANCE

- Turn off the "ON/OFF" rocker switch and/or thermostat (if installed).
- Turn off electric power to the appliance if service is to be performed.
- Turn gas control knob clockwise to "OFF". Do not force.

This appliance needs fresh air for safe operation and must be installed so there are provisions for adequate combustion and ventilation air. See Installation and Operation Manual accompanying appliance.

WARNING: Improper installation, adjustment, alteration, service or maintenance can cause injury or property damage. For assistance or additional information, consult a qualified installer, service agency or your gas supplier.

Operation of this appliance when not connected to a properly installed and maintained venting system can result in carbon monoxide (CO) poisoning and possible death.

SHUTDOWN PROCEDURE

- To turn off the burner, switch the rocker switch to "OFF" or adjust the thermostat to a setting below room temperature (if installed). The pilot will remain lit for future burner ignition.

For complete shutdown: See "TO TURN OFF GAS TO APPLIANCE" above.

Part No./ No. Pièce #36224 Rev. A, 05/2007

POUR VOTRE SÉCURITÉ, LIRE AVANT L'ALLUMAGE

AVERTISSEMENT: SI VOUS NE RESPECTEZ PAS RIGOREUSEMENT LES INSTRUCTIONS CI-DESSOUS, VOUS POURRIEZ ENCOURIR UN RISQUE D'INCENDIE ET/OU D'EXPLOSION QUI POURRAIT CAUSER DES DOMMAGES MATÉRIELS ET CORPORELS POUVANT ENTRAÎNER LA MORT.

DANGER: CET APPAREIL DÉGAGE DES TEMPÉRATURES ÉLEVÉES ET DEVIENDRAIT ÊTRE INSTALLÉ À L'ÉCART DES ENDROITS TRÈS PASSANTS ET LOIN DES MEUBLES ET RIDEAUX. GARDEZ LA ZONE AUTOUR DU Foyer EXEMPTÉ DE MATÉRIEL COMBUSTIBLES, D'ESSENCE ET AUTRES VAPEURS ET LIQUIDES INFLAMMABLES.

- Cet appareil utilise un système d'allumage par étincelle (allumeur Piézo-électrique) pour allumer la veilleuse. Assurez-vous de suivre rigoureusement les instructions d'allumage de la veilleuse.

- AVANT D'ALLUMER L'APPAREIL, assurez-vous qu'il n'y a pas d'odeur de gaz près de l'appareil ni près du sol car certains gaz plus lourds que l'air auraient tendance à s'y accumuler en cas de fuite.

QUE FAIRE SI VOUS SENTEZ UNE ODEUR DE GAZ:

- N'ALLUMEZ aucun appareil.
 - Ne touchez aucune prise électrique; N'utilisez aucun téléphone dans votre édifice.
 - Sortez de la maison. À partir d'un autre endroit, appelez immédiatement votre fournisseur de gaz et suivez les directives.
 - S'il est impossible de joindre le distributeur du gaz, appelez les pompiers.
- N'utilisez aucun outil pour tourner ou pousser le dispositif de contrôle du gaz. Si vous ne pouvez le faire manuellement, n'essayez pas de réparer l'appareil. Appelez un technicien de service qualifié. Si vous tentez de forcer ou réparer le dispositif de contrôle du gaz vous pourriez encourir un risque d'incendie et/ou d'explosion.
 - N'utilisez pas cet appareil si une de ses composantes a été émergée dans l'eau. Appelez immédiatement un technicien de service qualifié et reconnu afin qu'il inspecte et remplace au besoin toutes pièces du système qui auraient été en contact avec l'eau.

ALLUMAGE

DANGER: VOTRE APPAREIL AU GAZ LENNOX DOIT ÊTRE OPÉRÉ AVEC DES PORTES DE VERRE.

ATTENTION! Lisez les consignes de sécurité ci-dessous avant d'opérer votre appareil.

- Ouvrir la porte du bas. Assurez-vous que l'alimentation en gaz est à la position Fermée "OFF". Si l'appareil est équipé d'un thermostat, placez-le à la température la plus basse.
- Couper le courant électrique qui alimente l'appareil.
- Enfoncé légèrement le bouton de contrôle du gaz et tournez-le dans le sens des aiguilles d'une montre à la position "OFF".

NOTE: Le bouton de contrôle du gaz ne peut être tourné de la position "PILOT" à "OFF" sans qu'une légère pression ne soit appliquée.

- Attendez au moins 5 minutes pour que le gaz qui se trouve dans la chambre de combustion puisse s'échapper. Si vous sentez une odeur de gaz ARRÊTEZ! Référez-vous à la section B ci-dessus. Si vous ne sentez pas d'odeur de gaz, allez à la prochaine étape.
- Localisez le pilote au centre dans le bas de la bûche arrière. Une flamme bleue est visible lorsque la veilleuse est allumée.

- Tournez le bouton de contrôle de gaz dans le sens inverse des aiguilles d'une montre pour le placer sur "PILOT".
- Cet appareil de chauffage est équipé d'un système d'allumage par étincelle (allumeur Piézo-électrique), devant être utilisé pour l'allumage de la veilleuse. Poussez complètement le bouton de contrôle du gaz et le maintenir dans cette position. Appuyez immédiatement sur le bouton (allumeur Piézo-électrique) situé à gauche du robinet de contrôle du gaz. L'étincelle produite par l'allumeur Piézo-électrique doit allumer la veilleuse. Continuez à maintenir le bouton de contrôle dans cette position pendant environ 30 secondes après l'allumage de la veilleuse. Relâchez le bouton de contrôle du gaz qui reviendra à la position initiale. La veilleuse doit rester allumée. Répétez les étapes 4 à 8 pendant 15 secondes supplémentaires si la veilleuse s'éteint.

- Si le bouton de contrôle du gaz ne revient pas à la position initiale une fois relâché, appeler immédiatement un technicien qualifié ou votre distributeur de gaz.
- Si la veilleuse ne reste pas allumée après plusieurs essais, tournez le bouton de contrôle du gaz à la position "OFF" et appelez immédiatement un technicien qualifié ou votre distributeur de gaz.
- Lorsque la veilleuse est allumée, tournez le bouton de contrôle du gaz dans le sens inverse des aiguilles d'une montre pour le placer à la position "ON". Le bouton de contrôle peut-être tourné à la position "ON" seulement si il n'est plus enfoncé.
- Pour allumer le brûleur, mettre l'interrupteur à la position "ON" ou ajustez le thermostat à la température souhaitée.
- Ajustez la flamme et la température souhaitée en tournant le bouton de réglage de la flamme dans le sens des aiguilles d'une montre pour l'abaisser et dans le sens contraire pour l'augmenter.
- Allumez l'alimentation électrique de l'appareil.
- Ajustez le ventilateur au volume désiré lorsque l'appareil aura atteint la température de fonctionnement.

POUR COUPER L'ALIMENTATION EN GAZ DE L'APPAREIL

- Fermez l'interrupteur et/ou le thermostat «MARCHE/ARRÊT».
- Coupez l'alimentation électrique de l'appareil si vous prévoyez en faire le service.
- Tournez le bouton de commande du gaz dans le sens des aiguilles d'une montre à "OFF". Ne le forcez pas.

Cet appareil a besoin d'air frais pour opérer sécuritairement et doit être installé pour qu'il y ait un apport en air suffisant. Référez-vous aux manuels d'entretien et d'installation fournis avec l'appareil.

AVERTISSEMENT: Une installation inadéquate, un mauvais ajustement, une altération ou toutes autres modifications inappropriées pourraient entraîner des blessures physiques et/ou des dommages matériels. Référez-vous au guide d'utilisation fourni avec ce foyer. Pour assistance ou information supplémentaires contactez un installateur qualifié, un agent de service ou un fournisseur de gaz.

Si vous opérez cet appareil sans qu'il ne soit correctement raccordé à un conduit d'évacuation, vous pourriez risquer d'être empoisonné au monoxyde de carbone (CO) ce qui pourrait entraîner des conséquences grave ou la mort.

PROCÉDURE D'ARRÊT

- Pour arrêter le brûleur, mettre l'interrupteur à la position "OFF" ou ajustez le thermostat à une température en dessous de la température ambiante. La veilleuse restera allumée pour permettre un allumage ultérieur.

Pour un arrêt complet: Consultez la procédure ci-dessus «POUR COUPER L'ALIMENTATION EN GAZ DE L'APPAREIL».

IGN

WARRANTY

Your gas stove is covered by a limited warranty (provided with appliance). Please read the warranty to be familiar with its coverage.

Retain this manual. File it with your other documents for future reference.

PRODUCT REFERENCE INFORMATION

We recommend that you record the following important information about your appliance. Please contact your Lennox Hearth Products dealer for any questions or concerns. For the number of your nearest Lennox Hearth Products dealer, please call 1-800-9-LENNOX.

REPLACEMENT PARTS

See **Page 24** for a complete replacement parts list. Use only parts supplied from the manufacturer.

Normally, all parts should be ordered through your Lennox Hearth Products distributor or dealer. Parts will be shipped at prevailing prices at time of order.

When ordering repair parts, always give the following information:

1. The model number of the appliance.
2. The serial number of the appliance.
3. The part number.
4. The description of the part.
5. The quantity required.
6. The installation date of the appliance.

If you encounter any problems or have any questions concerning the installation or application of this system, please contact your dealer.

LENNOX HEARTH PRODUCTS

1110 West Taft Avenue
Orange, CA 92865
Visit us at www.Lennox.com

Your Stove Model Number _____
Your Stove's Serial Number _____
The Date On Which Your Stove Was Installed _____
The Type of Gas Your Stove Uses _____
Your Dealer's Name _____
Fuel Type (Check one) Natural Gas Propane Gas (LP)

NATIONAL
FIREPLACE
INSTITUTE



CERTIFIED
www.nficertified.org

We recommend that our gas hearth products be installed and serviced by professionals who are certified in the U.S. by the National Fireplace Institute® (NFI) as NFI Gas Specialists.

NATIONAL
FIREPLACE
INSTITUTE



CERTIFIED
www.nficertified.org

Nous recommandons que nos foyers au gaz soient installés et que l'entretien soit effectué par des professionnels certifiés par le National Fireplace Institute® (NFI). (Etats-Unis seulement)

Lennox Hearth Products reserves the right to make changes at any time, without notice, in design, materials, specifications, prices and also to discontinue colors, styles and products. Consult your local distributor for fireplace code information.

LENNOXTM

HEARTH PRODUCTS